



**Mallory Square Berth**  
**Alternatives Analysis 2<sup>nd</sup> Revision**

D3334102 |

April 22, 2024

**The City of Key West**

**FINAL**



## Mallory Square Berth

**Project No:** D3334102  
**Document Title:** Updated Improvements Study  
**Document No.:** D3334102-003  
**Revision:** 3  
**Date:** April 22, 2024  
**Client Name:** The City of Key West  
**Project Manager:** Jim Moore  
**Author:** Melynne Chiariello

Jacobs Engineering Group Inc.

445 Challenger Road  
 Suite 130  
 Cape Canaveral, FL 32920  
 United States  
 T +1.321.779.1236

[www.jacobs.com](http://www.jacobs.com)

© Copyright 2019 Jacobs Engineering Group Inc. The concepts and information contained in this document are the property of Jacobs. Use or copying of this document in whole or in part without the written permission of Jacobs constitutes an infringement of copyright.

Limitation: This document has been prepared on behalf of, and for the exclusive use of Jacobs' client, and is subject to, and issued in accordance with, the provisions of the contract between Jacobs and the client. Jacobs accepts no liability or responsibility whatsoever for, or in respect of, any use of, or reliance upon, this document by any third party.

### Document history and status

Revision	Date	Description	Author	Checked	Reviewed	Approved
00	8/19/2021	Draft revision per Client request	MKC	JDM	MM	JDM
01	8/24/2021	Final revision per client request	MKC	JDM	MM	JDM
02	3/12/2024	2 <sup>nd</sup> Draft revision per Client request	MKC	JDM		JDM
03	4/22/2024	Final revision per client request	MKC	JDM		JDM

## Contents

<b>Executive Summary</b> .....	<b>iii</b>
<b>1. Introduction and Background</b> .....	<b>1</b>
<b>2. Data Collection</b> .....	<b>2</b>
2.1 Existing Conditions.....	2
2.1.1 T-Pier .....	2
2.1.2 Wharf Dolphins .....	3
2.1.3 Monopiles .....	3
2.1.4 Breasting Dolphins.....	3
2.1.5 T-Pier Integral Breasting Dolphin .....	3
2.2 Vessels Using Mallory .....	4
2.3 Operational Observations.....	4
<b>3. Existing Gangway Operations</b> .....	<b>5</b>
3.1 Shell Door Horizontal Position and the T-Pier Length .....	5
3.2 Shell Door Vertical Position and the T-Pier Height.....	5
3.3 T-Pier Width .....	5
<b>4. Existing Mooring Conditions</b> .....	<b>7</b>
<b>5. Improvement Alternatives</b> .....	<b>8</b>
5.1 Dock Widening and Extension .....	9
5.2 Additional Monopile Dolphin.....	9
5.3 Approach Trestle Replacement.....	9
<b>6. Updated Operations and Mooring Conditions</b> .....	<b>11</b>
<b>7. Cost Estimate</b> .....	<b>14</b>
<b>8. Conclusions</b> .....	<b>15</b>

## Executive Summary

The wharf at Mallory Square is owned and operated by the City of Key West and has been used as a port of call for cruise ships since the 1980s. Over time, various structural additions and changes were made to accommodate new classes of cruise ships. In 2019 Jacobs prepared an Improvement Study with recommendations to modify the T-pier to improve the safety and usability of the berth for the various vessels that call at Mallory Square. In 2021, the City of Key West requested that Jacobs update the study to determine if alterations to the recommended improvements are warranted based on limiting the ship length to a maximum of 664 feet. The current request is to reevaluate the recommended improvements subject to the following changed criteria:

1. Design vessels no larger than 514 feet at the waterline
2. Design vessels with a carrying capacity no greater than 500 people, including passengers and crew.

The existing structures consist of a 115'-2" long by 16'-0" wide T-Pier with an integrated dolphin, three standalone dolphins, one monopile dolphin, a 16-foot-wide approach trestle, and two mooring bollards located on the Mallory Square Wharf.

Jacobs has updated the list of cruise ships used in this evaluation study from the 2021 study. The list was adjusted to remove vessels exceeding 514 feet in length at the waterline as well as vessels with a carrying capacity exceeding 500 people.

In evaluating the efficiency and safety of the operations, the locations of the vessel's shell doors with respect to the T-pier were considered. The T-pier was designed at a time when cruise ships were much smaller and safety standards were less developed. In the 1980s, passenger operations occurred near midship where the single elevator bank was located. Newer ships have two elevator banks, one forward and one aft, in accordance with safety standards. The passenger shell doors are located in relation to the position of the elevator banks onboard the ship. As such, there are less ships with door locations at midship.

The current berth configuration centers the T-Pier alongside the ship. Because the pier does not span sufficiently aft, the largest of the ships cannot place the passenger shell doors on the pier to allow for passenger debarkation and embarkation without encroachment into the adjacent submerged lands lease.

The narrowness of the pier may cause the gangway's landing ramp to extend to or beyond the landward edge of the T-pier. This configuration leads to a dangerous condition when debarking the ship with a steep downward walkway without a suitable landing clearance on the pier deck surface.

A number of improvements are proposed to provide a safer and more operationally efficient process. The improvements include a new lengthened and widened T-Pier and a new approach trestle as well as a new monopile mooring dolphin. Construction of these components will allow for sufficient space for gangway operations and proper mooring positions.

## 1. Introduction and Background

The wharf at Mallory Square has been used as a port of call for cruise ships since the 1980s. Over time, various structural additions and changes were made to accommodate new classes of cruise ships. As shown in Figure 1, the current berth at Mallory Square consists of a T-Pier that is 115'-2" long and 16 feet wide with an elevation of 6'-8" Mean Low Water (MLW). In addition, there are three breasting dolphins and one monopile mooring dolphin for the berth. The berth is situated within the limits of a submerged lands lease of 2.3 acres with a length of 514 feet.

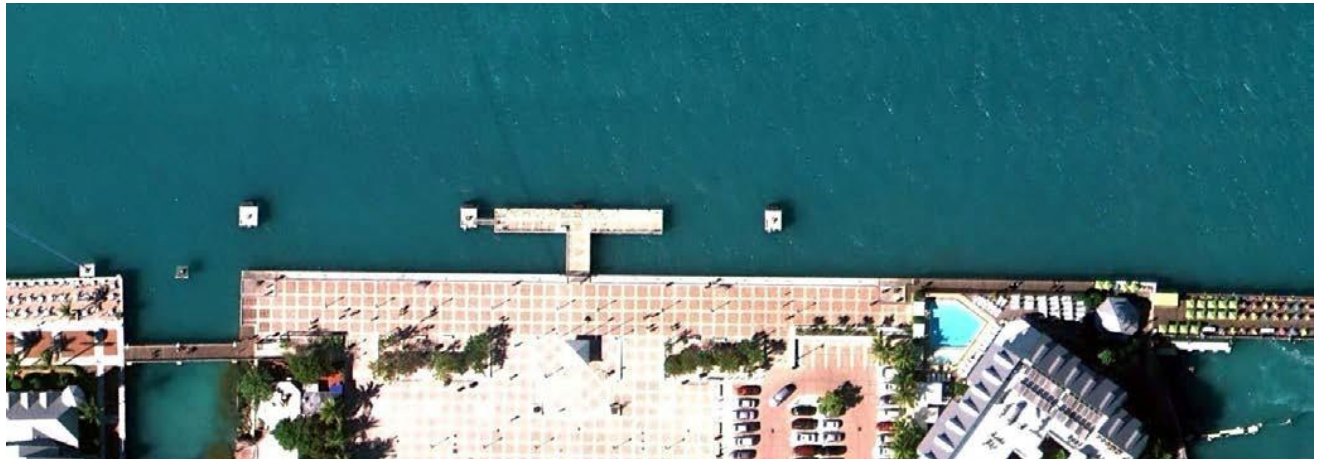

Figure 1: 2018 Mallory Square Berth Configuration and Study Area

Mallory Square wharf is adjacent to Pier B (privately owned and operated), and the Navy Mole Pier to the south and the Five-Star Ocean Key Resort & Spa to the north. Pier B and the Navy Mole Pier are also used concurrently for the berthing of cruise ships.

In 2010, the entire Mallory Square wharf structure was reconstructed. In 2017, portions of the T-pier at Mallory were reconstructed to provide for increased safety for ships at the berth. In 2018, the Silver Spirit struck the southern-most breasting dolphin, which required installation of a new breasting dolphin approximately 25 feet north of the damaged dolphin.

While these projects may have improved serviceability of the berth to a small extent, the primary purpose of these changes was to restore structural capacity. Further changes and additions are necessary to continue to improve the safety and usability of the berth for the various vessels that call at Mallory Square.

To this end, the City of Key West has requested that Jacobs perform a study to determine alternatives that will improve the passenger safety and experience as well as improve mooring and berthing flexibility for vessels up to 514 feet in length using Mallory Square.

The improvements evaluated include additional mooring points in the form of mooring/breasting dolphins and monopile mooring points. In addition, improvements to the footprint of the T-Pier for passenger embark/debark activities and additional dock space connecting remote mooring dolphins with the T-Pier, and connection to the main wharf is also evaluated. The improvements will consider the limitations posed by the adjacent properties and their usage.

## 2. Data Collection

### 2.1 Existing Conditions

The survey used to layout the proposed improvements is the 2020 Hydrographic survey conducted by Florida Keys Land Surveying along with as-builts of the wharf and T-Pier improvements.

The existing structures at the Mallory Square Berth are shown in Figure 2 and consist of a variety of distinct marine structures each serving a specific purpose. The main wharf is a pile supported structure that serves as the interface between the T-Pier and the land. Integrated into this wharf at each waterside end are drilled shaft supported mooring dolphins with a 150-metric ton bollard on each structure. These bollards serve currently as the main bow and stern mooring points for the berth. The ship is accessed via a T-Head pier. Known as the T-Pier, this pile supported structure has an integrated berthing dolphin as well as water and wastewater services. This is the main platform from which passengers embark and debark from the ship.

In line with the outside fender face of the T-Pier are three standalone breasting dolphins. Two of these dolphins were constructed in the mid to late 1990s, while the southern inner most dolphin was constructed in the mid-1980s. In 2018, a vessel collided with the existing southern outer dolphin resulting in a total loss of the dolphin. In 2019, the damaged dolphin was removed, and a new dolphin structure was constructed approximately 25 feet to the north of its original position. Each breasting dolphin is a prestressed concrete pile-supported structure with a foam filled fender and mooring bollard.

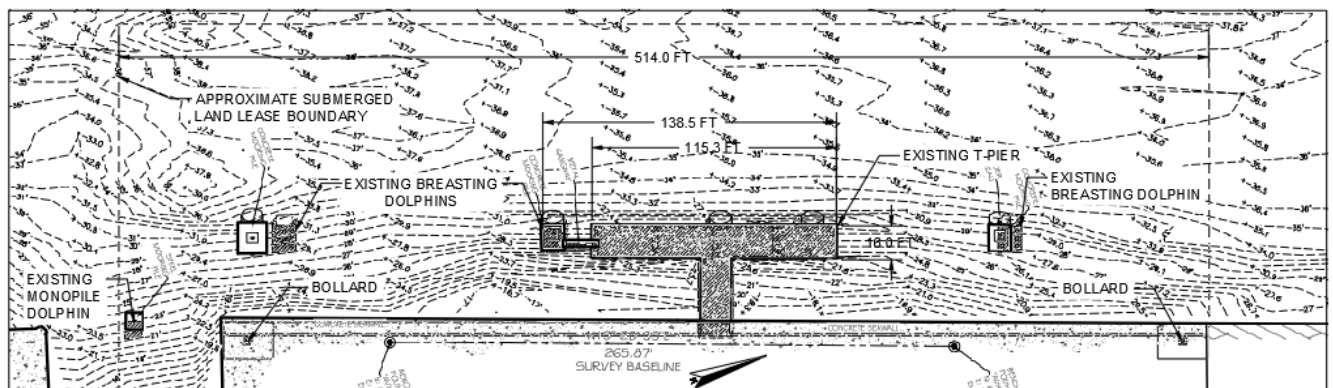

Figure 2: Existing Conditions

Each of these individual structures is described in detail in the sections below.

#### 2.1.1 T-Pier

The T-pier connects Mallory Square to Mallory Wharf and thus to the City of Key West. As previously stated, the T-pier was originally designed in 1985 when cruise ships were much smaller with fewer passengers. The existing T-pier is 115'-2" long and 16'-0" wide. It is constructed of precast, prestressed deck panels with a topping, supported by cast in place pile caps. The pile caps are supported by 18" square prestressed concrete piles. The northern 28'-4" portion of the T-pier was replaced in 2016 with a steel pipe pile supported breasting dolphin. The remainder of the T-pier had spot repairs to fix spalls and cracks in the concrete in 2018; however, the overall structure is 36-years old and nearing the end of its useful life.

The T-pier design was problematic in that as cruise ships increased in size, the forces transmitted into the T-pier from the fenders caused some damage to the caps and deck of the T-pier. The 2016 dolphin project moved the main fender forces off of the remaining portion of the T-pier which has helped with these damaging forces.

### 2.1.2 Wharf Dolphins

There are dolphins located at the extreme ends of the Mallory Square wharf with a separation of approximately 440'. The current position of these dolphins was dictated by the boundaries of Mallory Square wharf and the boundaries of the property owned by the City of Key West. The dolphins are integrated into the footprint of the wharf to allow for alignment with the face of the wharf. Each location has a 150 MT bollard mounted to a pile cap and supported by 6 drilled shafts.

### 2.1.3 Monopiles

At the southern end of Mallory Square Wharf, there is an existing monopile mooring dolphin. It consists of a large diameter steel pipe pile driven to elevation -58'-0" MLW. A mooring bollard is affixed on top of the monopile. The original capacity of the monopile was approximately 85 metric tons when constructed in 1997. The monopile is approximately 96" in diameter.

### 2.1.4 Breasting Dolphins

Currently, there are three standalone breasting dolphins located at Mallory Square Berth: the south outer dolphin, the south inner dolphin, and the north outer dolphin. The dolphins were constructed at different times and have different characteristics.

The south inner dolphin was constructed at the time of the original wharf project in 1985. This dolphin is connected to the T-Pier with a small aluminum catwalk. The dolphin has eight- 18" square precast prestressed concrete piles as the foundation with an 11'-0" x 12'-6" x 6'-0" concrete cap. The piles are driven into the limestone layer below -40' MLW. The piles have an H-pile stinger to achieve the required tension capacity of 30 Tons. The piles have a compression capacity of 120 Tons. The dolphin has a 70 metric ton bollard as well. The design fender load is unknown as the fender type specified in the original project cannot be located in the documentation. The proposed fenders exert a 190-kip maximum rated fender reaction.

The north outer dolphin was constructed in 1996, and the south outer dolphin replacement was constructed in 2019. These dolphins are of a similar configuration to the south inner dolphin. The 8-pile structure has an 11'-0" x 12'-6" x 6'-0" concrete cap. The main difference in the structure is that the outer dolphin has 24" piles instead of 18" piles. These piles are also installed into the limestone layer and have a stinger to achieve tension capacity. The pile requirements are 125 Tons capacity for compression. Tension loads are not specified on the drawings. The original fender was a Seibu arch type fender with a steel fender face panel. The fender size would invoke a 190-kip reaction to the structure. The new fender attached to the dolphin are Trelleborg Seaguard foam-filled fenders. This fender applies a 190-kip force to the structure as well. There is also a 75-metric ton bollard on the dolphin.

### 2.1.5 T-Pier Integral Breasting Dolphin

The Northern 28'-4" +/- of the original T-pier was selectively demolished to allow for the installation of a new integral dolphin at the end of the pier. This new dolphin is 28'-4" x 16'-0" x 6'-0" and falls within the same footprint as the existing T-Pier. The dolphin is supported by six 36" reinforced concrete drilled shafts. The dolphin has a 5'-6" x 11'-3" floating foam filled fender attached to it at the breasting face. The fender exerts a 190-kip force to the structure. However, the structure is designed to withstand a much higher 300-kip force. As this dolphin is integrated with the existing T-Pier, it had to maintain the footprint of the structure.

## 2.2 Vessels Using Mallory

In the original study, a data collection effort to gather a list of the ships utilizing Mallory Wharf was performed. In 2021, the study was updated to remove vessels exceeding 664 feet in length. For this study, vessels exceeding 514 feet in length at the waterline were removed. The Silver Wind, whose length overall is 512 feet, remained in the table as the total capacity for passengers and crew is 471; however, the maximum capacity criteria of 500 people can be exceeded if the third berths are occupied.

A list of remaining vessels for this study can be seen below in Table 1.

Table 1: Vessels in Study

Cruise Line	Parent/ Owner	Ship Name(s)	Length Overall (feet)	Beam (feet)	Draft (feet)	Passenger/Crew
American Cruise Lines	American Cruise Lines	American Glory	239	56	7	100/22
Hurtigruten	Hurtigruten AS	Fram	374	66	14	254/89
Silversea Cruises	Royal Caribbean Group	Silver Wind	512	69	15	274/197
Victory Cruise Lines	Victory Cruise Lines	Victory II	300	49	13	210/81

Based on this updated list, the deck plans and ship outlines were developed from mid-level deck plans available from the cruise lines and supplemented with photographs available online. These vessel outlines along with knowledge of the vessels' operations are used to position the ship on the berth at its operational location. As a port of call, the vessel must be positioned so that at least one gangway is on the pier, adequate mooring line arrangements are available, and sufficient fendering is present.

## 2.3 Operational Observations

Conversations with City personnel, ships agents and cruise lines were conducted to collect information on the current mooring, berthing, and passenger operations for each of the vessels. Videos of the vessel operations from berthing to departure are available in the public domain. These videos were helpful in viewing the overall passenger flows and mooring line handling operations.



### **3. Existing Gangway Operations**

Of primary concern with operations were the locations of the vessel's shell doors with respect to the T-pier. All passengers debarking and embarking must use the T-pier to access the ship. The T-pier was designed at a time when cruise ships were much smaller and safety standards were less developed. As discussed previously, the T-Pier is 115 feet in length and 16 feet in width at an elevation of 6.5 MLLW. The sections below will discuss how these parameters affect the operations.

#### **3.1 Shell Door Horizontal Position and the T-Pier Length**

Various shell gates (doors) are located along the side of the ship spanning from the bow to the stern. The passenger shell gates are located in relation to the position of the elevator banks onboard the ship. In the 1980s, passenger operations occurred near midship where the single elevator bank was located. Most newer ships have two elevator banks, one forward and one aft, in accordance with safety standards. As such, there are less ships with door locations at midship; however, ships smaller than 500 feet often have only one passenger door located midship.

The current berth configuration centers the T-Pier alongside the ship. On the largest vessel in the study, the shell gate does not interface with the pier unless the ship moves forward and encroaches on the adjacent submerged land lease.

#### **3.2 Shell Door Vertical Position and the T-Pier Height**

In the early years of cruising, the lowest level shell gates were generally positioned at 6.9 to 8.0 feet above the waterline. The shell gates for the newer vessels (no matter the size) are positioned 9.4 to 11 feet above the waterline. For catamaran vessels such as the American Glory, the embarkation deck is low, roughly 6 feet above the waterline.

Although the deck elevation for most new cruise berths is a minimum of 8.5 feet in Florida and the Caribbean area where tides are slight, given the potential usage by catamaran vessels, the pier height of 6.5 feet was maintained.

#### **3.3 T-Pier Width**

The narrowness of the pier may cause the gangway's landing ramp to extend to or beyond the landward edge of the T-pier (Figure 3). This configuration leads to a dangerous condition when debarking the vessel with a steep downward walkway without a suitable landing clearance at the pier deck surface. To comply with the Americans with Disabilities Act, a level landing of a least 60" is required. The pier is currently 16 feet wide with a usable area of 14 feet due to the required curbs on either side of the pier.

In addition to the safety issues this situation causes, it also slows the embarkation and debarkation processes. Furthermore, while in port, the ships may need to take on provisions. The provisions may be brought via forklift or utility vehicle. Widening the T-pier to 25 feet will improve passenger safety during embark/debark to meet ADA requirements and will facilitate any provisioning that might take place.



Figure 3: Silversea Gangway at Mallory Square

## 4. Existing Mooring Conditions

Prior to the COVID-19 mandated No-Sail Order issued by the CDC, ships mooring at Mallory square ranged from 300' LOA to approximately 800' LOA; however, the City has implemented a new policy to limit the vessels calling at the berth to 514 feet length at the waterline.

Most cruise ships preferentially moor starboard side to the berth since their primary tender and lower passenger doors are located on the starboard side of the ship; therefore, they will utilize a mooring arrangement with the shell doors lining up with the T-Pier. Some ships will access the Northern end of the T-pier, while some access the middle to southern end of the T-Pier. As discussed in the previous section, the ship's position longitudinally may be limited by the location of the passenger door that will be used for embark/debark activities. This may lead to the ship being moored in a less favorable position with respect to the mooring points.

With the exception of the southern outer dolphin, the breasting/mooring dolphins are clustered near the mid ship point. The primary force when mooring a ship are those from broadside winds pushing the ship off of the wharf. Breasting lines are used to keep the vessel alongside and prevent outward movement referred to as sway. They are most efficient when perpendicular to the ship. As the lines become less perpendicular, their efficiency decreases geometrically and increases the load imparted on the mooring lines. Ideally, mooring points at the bow and the stern should have a similar configuration to prevent yaw, wherein either the bow or the stern rotates away from the berth while the opposite end rotates toward the berth.

Due to the current configuration of the dolphins, the breasting line angles afforded to vessels over 500' LOA are not ideal. The position of these lines is at an angle close to 45 degrees to the vessel. Lines at this angle allow for excessive vessel sway or yaw. Although the southern outer mooring dolphin provides stability to the stern during high winds that can cause excessive movement in the vessel, the absence of a dolphin to the north contributes to excessive movement of vessels in higher winds. To provide for additional flexibility in the mooring arrangement, additional mooring points should be added closer to the bow and stern of the vessels.

Depending upon the size and location of the shell doors, a port-to mooring may be problematic based on the location of the berth's breasting dolphins. With the larger ships, there would be no dolphin prior to the bow curve to provide lateral stability.

## 5. Improvement Alternatives

As mentioned in the introduction, the goal of this study is to look at improvements that can be made that allow for the most flexibility, safety, and land lease compliance with respect to the location of the ships utilizing the berth. To this end, there are several proposed improvements to the T-pier that have been developed. These improvements include widening and extending the deck of the T-pier, as well as raising the deck in certain areas. Furthermore, the approach trestle to the T-pier should be replaced. In addition to these improvements, operational improvements may include catwalks upgrades to the remote mooring dolphins.

The improvements begin with selective demolition. As the T-pier and approach trestle are nearing the end of their useful lives, it is recommended that the original structures be demolished as opposed to retrofitted. The proposed demolition is shown in Figure 4. The existing approach trestle and the T-Pier with the exception of the integral dolphin section on the northern end of the structure will be demolished. It is possible that the existing T-pier could be widened and extended; however, the existing pier and concrete pile supported dolphin are likely to have structural issues due to age and usage by vessels larger than the original design vessels. Integrating a long-life structure with it would not be cost-efficient and may exacerbate any hidden structural damage; therefore, we do not recommend that approach. Demolition of these concrete pile support sections is therefore recommended as shown in Figure 4. All of the existing dolphins will remain except for the southern inner dolphin.

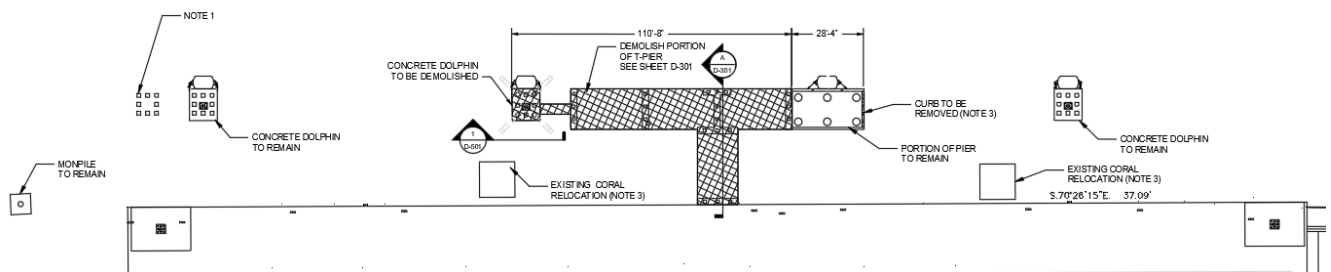

Figure 4: Proposed Demolition

The proposed improvements are shown in Figure 5. The improvements include a new T-Pier and approach trestle as well as a new mooring dolphin. The new T-Pier surrounds the one remaining existing dolphin area providing a wider and longer berth and includes a wider approach trestle.

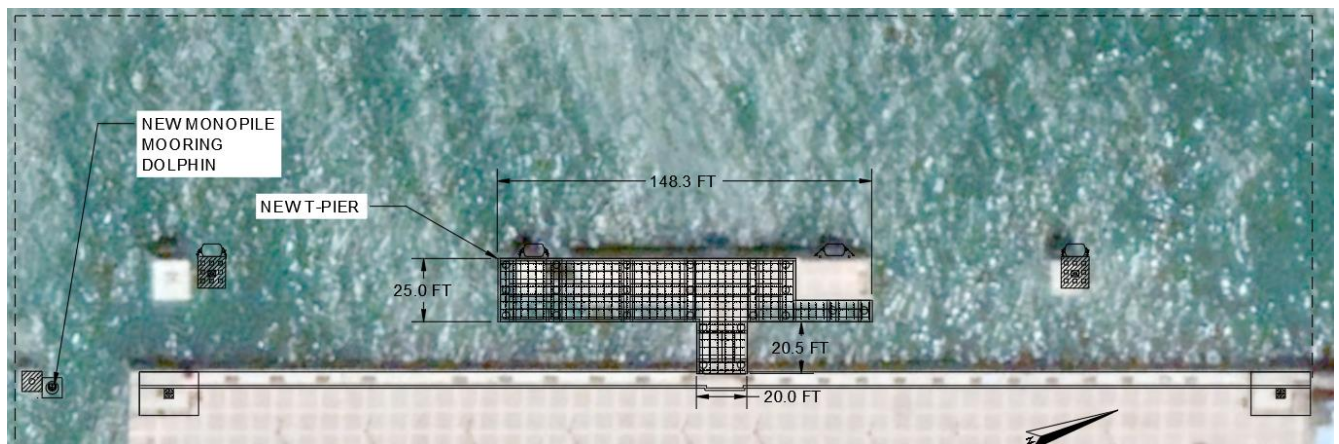

Figure 5: Proposed improvements

## 5.1 Dock Widening and Extension

The operational limitations discovered during the data collection exercise showed that lengthening the pier would allow for safer and more optimal access to a majority of the vessels. Lengthening the pier to the south will be the most effective in allowing for better positioning of the ships along the pier and to match with the location of most passenger doors. The new length of the pier will be 148'-3". The lengthening will be in the southern direction.

The pier is proposed to be widened from 16 feet to 25 feet. The additional width will improve accessibility and safety so that the conditions as shown in Figure 3 no longer occur.

The pier would require a new 100-ton bollard as well as four 30-ton cleats (two at each end) to accommodate the smaller vessels. In addition, the southern end of the pier would be outfitted with a new foam filled fender.

With the removal of the inner southern dolphin, the height of the new T-Pier would remain at 6.5 feet as shown in Figure 6.

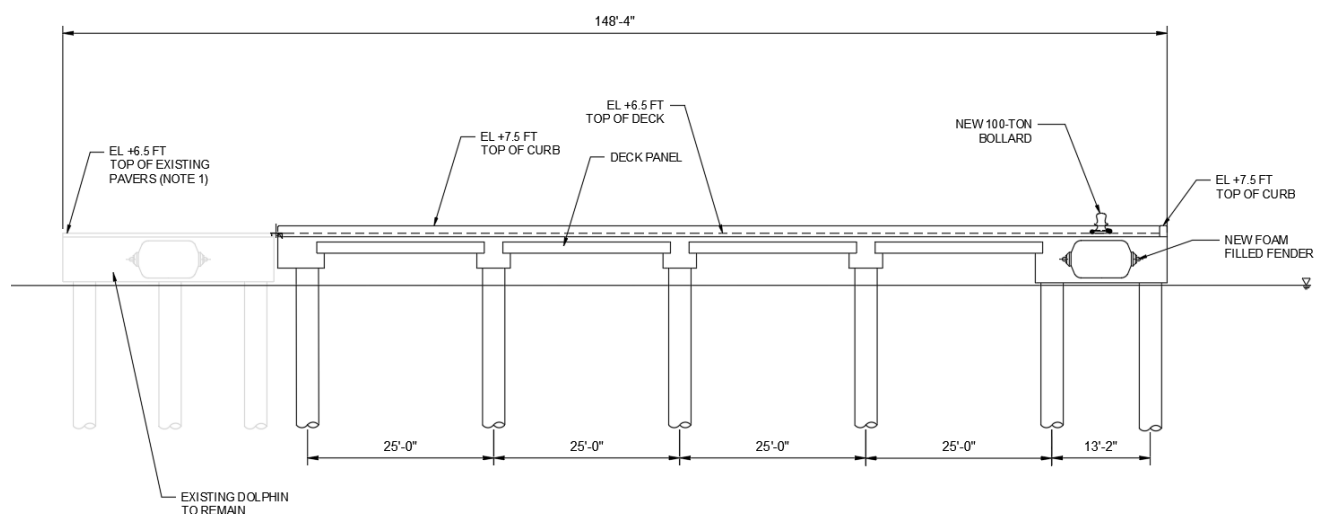

Figure 6: Elevation View of Proposed T-Pier

## 5.2 Additional Monopile Dolphin

To increase the safety and flexibility of the vessel moorings at the Mallory Square Berth, an additional monopile dolphin should be constructed at the southern end of Mallory to allow for additional mooring points for more efficient line angles for the breast lines. The monopile dolphin would be fitted with a 150 metric ton bollard. This monopile would be required only by the larger vessels. This monopile is recommended as newer vessels tend to user higher strength mooring lines to reduce the number of lines required to safely moor.

## 5.3 Approach Trestle Replacement

The original study recommended widening the approach trestle from 16 feet to 20 feet to improve operations due to a proposed tender drop-off along the trestle. As that option has been removed from consideration, the current width of the trestle is sufficient; however, a 20-foot-wide trestle would provide a safer and more dynamic area which could accommodate utility vehicles.

As with the original T-pier, the structure is 39 years old and nearing the end of its useful life. It also had repair work completed in 2018 to repair spalls and large areas of delamination. It is recommended to replace the existing trestle. Although not presented in this report, a potable waterline extension on to the pier can be included with the proposed improvements as an additive alternate during bidding and construction.



## 6. Updated Operations and Mooring Conditions

As stated in Sections 3 and 4, the current limited footprint of the T-Pier negatively impacts the gangway operations and mooring conditions. Figures 7 through 12 illustrate “before and after” conditions for the Silver Wind, the Fram and the American Glory. In Figure 7, the passenger door of the Silver Wind is positioned in between the T-pier and the inner southern dolphin. To position the door on the T-pier would cause the ship to encroach on the submerged land lease to the north. Figure 8 depicts the changed condition with the proposed improvements. The ship is centered within the lease area and the passenger door is located on the pier. Furthermore, the widened pier would allow for a safe operation at the pier-gangway interface.

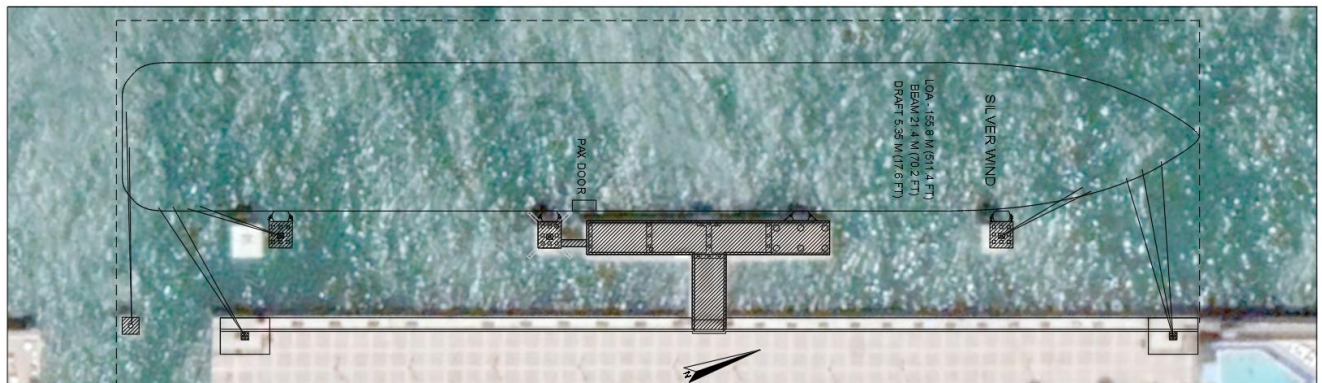

Figure 7: Silver Wind Existing Arrangement

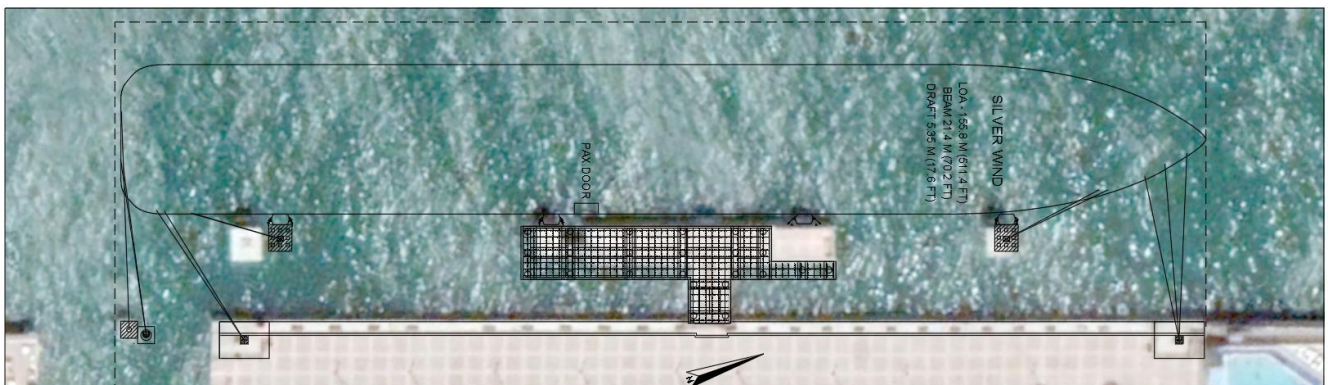

Figure 8: Silver Wind Proposed Arrangement

In Figure 9, the Fram is positioned to enable the vessel to embark and disembark passengers from their two passenger doors. The proposed improvements of the pier will not affect the mooring of the Fram as shown in Figure 10, although it will provide a larger pier area for embarkation/debarkation and supply operations.

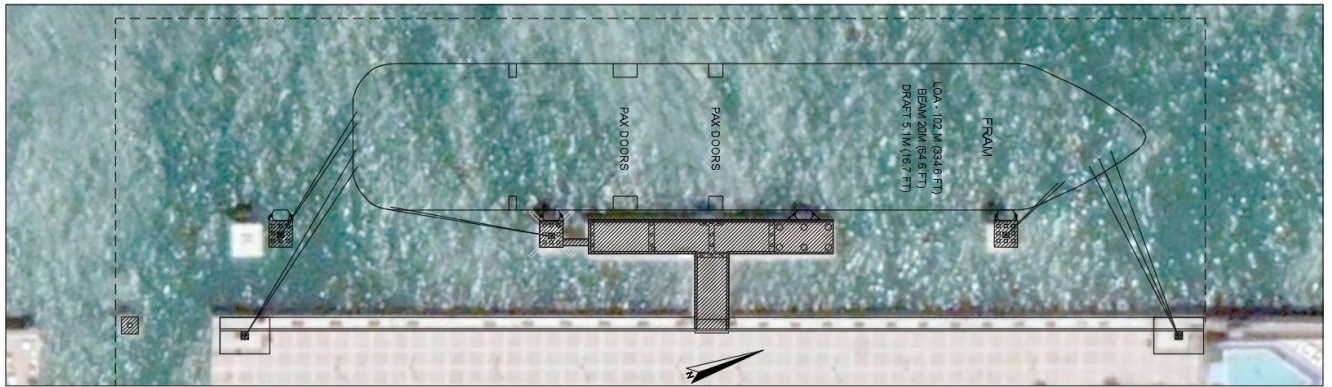

Figure 9: Fram Existing Arrangement

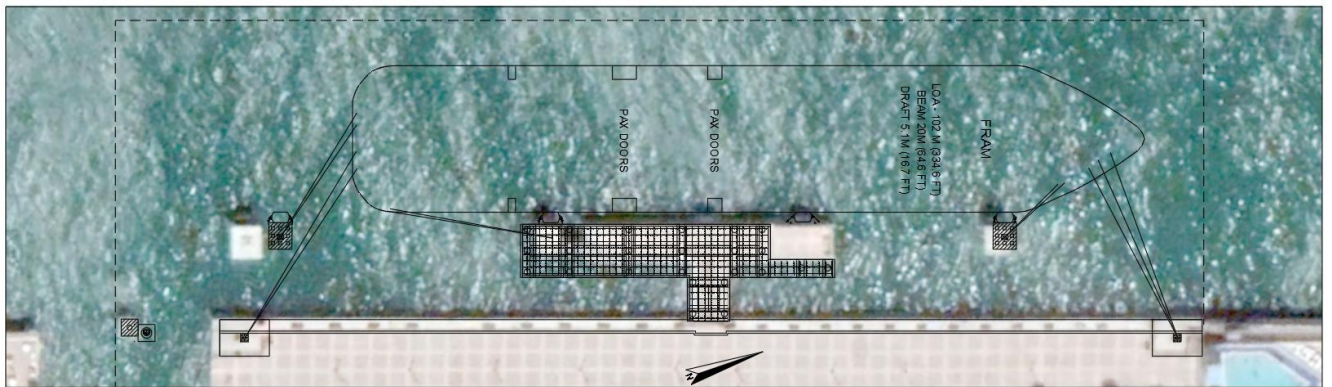

Figure 10: Fram Proposed Arrangement

In Figure 11, the American Glory is positioned to enable the vessel to embark and debark passengers from their passenger door. The proposed improvements of the pier will not affect the mooring of the American Glory as shown in Figure 12. For either arrangement, cleats will need to be provided along the T-pier.



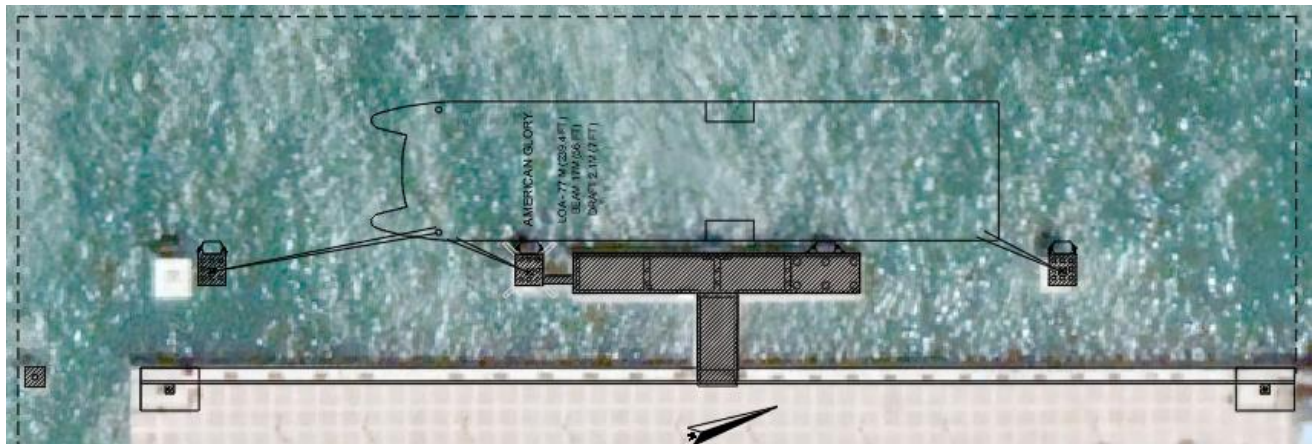

Figure 11: American Glory Existing Arrangement

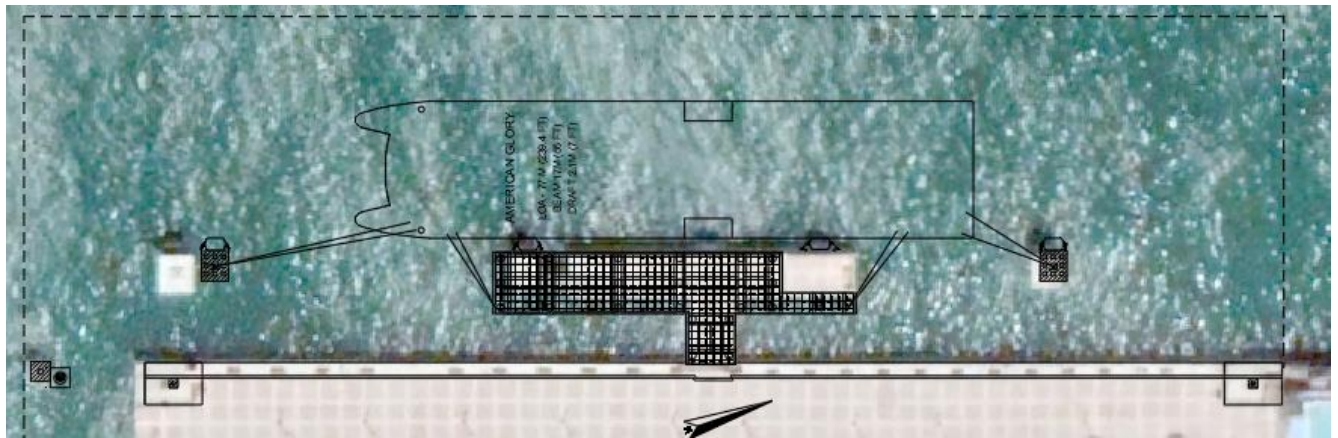

Figure 12: American Glory Proposed Arrangement

## 7. Cost Estimate

A cost estimate for the recommended improvements presented in this report is provided in Figure 13. These values are preliminary and subject to change during final design and project bidding.

Description	Quantity	Units	Unit Price	Extended Price
<b>Demolition</b>				
Demolition - Decking	2,062.00	SF	\$ 34.00	\$ 70,108.00
Demolition - Pile Cut Offs	21.00	EACH	\$ 9,130.00	\$ 191,730.00
Demolition - Dolphin	1.00	EACH	\$ 17,213.00	\$ 17,213.00
Demolition - Dolphin Piles	8.00	EACH	\$ 9,135.00	\$ 73,080.00
Demolition-Disposal	1.00	LS	\$ 40,703.00	\$ 40,703.00
<b>Sub-Total</b>				<b>\$ 392,834.00</b>
<b>Pier/Trestle Reconstruction</b>				
36" Dia x 3/8 x 36' piles w/ 50 feet of concrete	24	EACH	\$ 74,859.00	\$ 1,796,616.00
New deck/deck planks	3,619	SF	\$ 172.00	\$ 622,468.00
Pile Caps	120	CY	\$ 3,144.00	\$ 377,280.00
Cleats 25/50-ton	4	EACH	\$ 2,105.00	\$ 8,420.00
100 ton bollard	1	EACH	\$ 8,500.00	\$ 8,500.00
Foam Fender	1	EACH	\$ 60,000.00	\$ 60,000.00
Aluminum Handrail	42	FEET	\$ 224.00	\$ 9,408.00
Pavers	3,619	SF	\$ 40.00	\$ 144,760.00
Expansion Plates	45	SF	\$ 118.00	\$ 5,310.00
<b>Sub-Total</b>				<b>\$ 3,032,762.00</b>
<b>Monopile Dolphin</b>				
Monopile deck	7.7	CY	\$ 5,000.00	\$ 38,500.00
60" Dia x 1-1/2" t x 49' Pile w/ Rock Socket	1	EACH	\$ 296,907.00	\$ 296,907.00
150 ton bollard	1	LS	\$ 10,350.00	\$ 10,350.00
Safety Ladder	1	EACH	\$ 8,790.00	\$ 8,790.00
<b>Sub-Total</b>				<b>\$ 354,547.00</b>
<b>Sub-Total for Materials and Services</b>				<b>\$ 3,780,143.00</b>
<b>General Conditions</b>				
Mobilization/Demobilization	1	LS	\$ 175,000.00	\$ 175,000.00
Environmental Controls	1	LS	\$ 38,400.00	\$ 38,400.00
Payment & Performance Bond	1	LS	\$ 47,922.52	\$ 47,922.52
<b>Total without Contingency</b>				<b>\$ 4,041,465.52</b>
Contingency	1	20%	\$ 808,293.10	\$ 808,293.10
<b>Total with Contingency</b>				<b>\$ 4,849,758.62</b>

Figure 13: Cost Estimate

## **8. Conclusions**

To help improve efficiency and safety at the Mallory Square cruise berth, the proposed improvements of widening and lengthening the pier should be made. A new monopile mooring dolphin should be constructed at the southern end of the berth for the largest vessels.

The older concrete pile supported sections of the T-pier should be demolished and reconstructed in a longer and wider footprint. It is also recommended that once the inner south mooring dolphin is demolished, the pier be extended approximately 10 feet beyond the extent of the end of the demolished dolphin for accommodation of vessels with a variety of door locations. The final recommended improvement is the construction of a new wider approach trestle.