

Notice to Bidder: Use Black Ink or Type For Completing the Form.

BID FORM

To: The City of Key West
Address: 525 Angela Street, Key West, Florida 33040
Project Title: ITB # 11-012: MARINE GRADE POWER DOCK PEDESTALS

BIDDER'S INFORMATION

Name: Sea Port Marine Corporation
Address: 812 Professional Place
Chesapeake, VA 23320
Contact Name: Phil Henline
Email: phil@seaport-marine.com
Telephone: 757-436-4400 800-446-8056
Fax: 757-436-1460

BIDDER'S DECLARATION AND UNDERSTANDING

The undersigned, hereinafter called the Bidder, declares that the only persons or parties interested in this Bid are those named herein, that this Bid is, in all respects, fair and without fraud, that it is made without collusion with any official of the Owner, and that the Bid is made without any connection or collusion with any person submitting another Bid on this Contract.

COMPLETION TIME

The Bidder further agrees to furnish the items within ninety (90) days of issuance of the purchase order

SALES AND USE TAXES

The Bidder agrees that all federal, state, and local sales and use taxes are included in the stated bid prices for the work.

BID FORM

ITB # 11-012: MARINE GRADE POWER DOCK PEDESTALS

Item	Units	Unit Measure	Unit Price	Total
Marine Grade Power Dock Pedestals	49	each	\$821.75	\$40,265.75
			Shipping	\$0.00
			Total	\$40,265.75

LUMP SUM BID PRICE

\$ 40,265.75

Bid Total in Words

Forty Thousand Two Hundred Sixty Five Dollars and 75 Cents

BIDDER

The name of the Bidder submitting this Bid is: Sea Port Marine Corporation

Doing business at 812 Professional Place

City Chesapeake State VA Zip 23320

Telephone No. 757-436-4400 800-446-8056

The names of the principal officers of the Corporation submitting this Bid, or of the Partnership, or of all persons interested in this Bid as Principals are as follows:

Name	Title
<u>Robert Carriker</u>	<u>Vice President</u>

If Corporation

IN WITNESS WHEREOF the undersigned corporation has caused this instrument to be executed and its seal affixed by its duly authorized officers this 16th day of May, 2011.

(SEAL)

Name of Corporation

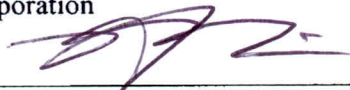
By: 

Title: Vice-President

Attest: 
Assitant Treasurer / Secretary

If Sole Proprietor or Partnership

IN WITNESS hereto the undersigned has set his/her/its hand this _____ day of _____, 2011.

Signature of Bidder _____

Title _____

**SWORN STATEMENT UNDER SECTION 287.133(3)(a)
FLORIDA STATUTES, ON PUBLIC ENTITY CRIMES**

**THIS FORM MUST BE SIGNED IN THE PRESENCE OF A NOTARY PUBLIC OR OTHER OFFICE
AUTHORIZED TO ADMINISTER OATHS.**

1. This sworn statement is submitted with Bid, Bid or Contract No. IBT NO: 11-012 for
Marine Grade Power Dock Pedestals

2. This sworn statement is submitted by Sea Port Marine Corporation
(Name of entity submitting sworn statement)
whose business address is 812 Professional Place
Chesapeake, VA 23320 and (if applicable) its Federal
Employer Identification Number (FEIN) is 54-1267270 (If the entity has no FEIN,
include the Social Security Number of the individual signing this sworn statement.)

3. My name is Robert Carriker and my relationship to
(Please print name of individual signing)

the entity named above is Vice President

4. I understand that a "public entity crime" as defined in Paragraph 287.133(1)(g), Florida Statutes, means a violation of any state or federal law by a person with respect to and directly related to the transaction of business with any public entity or with an agency or political subdivision of any other state or with the United States, including but not limited to, any bid or contract for goods or services to be provided to any public entity or an agency or political subdivision of any other state or of the United States and involving antitrust, fraud, theft, bribery, collusion, racketeering, conspiracy, material misrepresentation.

5. I understand that "convicted" or "conviction" as defined in Paragraph 287.133(1)(b), Florida Statutes, means a finding of guilt or a conviction of a public entity crime, with or without an adjudication of guilt, in any federal or state trial court of record relating to charges brought by indictment information after July 1, 1989, as a result of a jury verdict, nonjury trial, or entry of a plea of guilty or nolo contendere.

6. I understand that an "affiliate" as defined in Paragraph 287.133(1)(a), Florida Statutes, means
 1. A predecessor or successor of a person convicted of a public entity crime: or
 2. An entity under the control of any natural person who is active in the management of the entity and who has been convicted of a public entity crime. The term "affiliate" includes those officers, directors, executives, partners, shareholders, employees, members, and agents who are active in the management of an affiliate. The ownership by one person of shares constituting controlling interest in another person, or a pooling of equipment or income among persons when not for fair market value under an arm's length agreement, shall be a prima facie case that one person controls another person. A person who knowingly enters into a joint venture with a person who has been convicted of a public entity crime in Florida during the preceding 36 months shall be considered an affiliate.

7. I understand that a "person" as defined in Paragraph 287.133(1)(8), Florida Statutes, means any natural person or entity organized under the laws of any state or of the United States with the legal power to enter

into a binding contract and which bids or applies to bid on contracts for the provision of goods or services let by a public entity, or which otherwise transacts or applies to transact business with a public entity. The term "person" includes those officers, directors, executives, partners, shareholders, employees, members, and agents who are active in management of an entity.

8. Based on information and belief, the statement, which I have marked below, is true in relation to the entity submitting this sworn statement. (Please indicate which statement applies.)

Neither the entity submitting this sworn statement, nor any officers, directors, executives, partners, shareholders, employees, members, or agents who are active in management of the entity, nor any affiliate of the entity have been charged with and convicted of a public entity crime subsequent to July 1, 1989.

The entity submitting this sworn statement, or one or more of the officers, directors, executives, partners, shareholders, employees, members, or agents who are active in management of the entity, or an affiliate of the entity has been charged with and convicted of a public entity crime subsequent to July 1, 1989, AND (Please indicate which additional statement applies.)

There has been a proceeding concerning the conviction before a hearing of the State of Florida, Division of Administrative Hearings. The final order entered by the hearing officer did not place the person or affiliate on the convicted vendor list. (Please attach a copy of the final order.)

The person or affiliate was placed on the convicted vendor list. There has been a subsequent proceeding before a hearing officer of the State of Florida, Division of Administrative Hearings. The final order entered by the hearing officer determined that it was in the public interest to remove the person or affiliate from the convicted vendor list. (Please attach a copy of the final order.)

The person or affiliate has not been put on the convicted vendor list. (Please describe any action taken by or pending with the Department of General Services.)

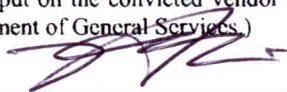

(Signature)

May 16, 2011

(Date)

STATE OF Virginia

COUNTY OF City Of Chesapeake

PERSONALLY APPEARED BEFORE ME, the undersigned authority,

Robert Carriker who, after first being sworn by me, affixed his/her signature in the
(Name of individual signing)

space provided above on this 16th day of May, 2011.

My commission expires: 7-31-2013

Gloria Mae Seyler
NOTARY PUBLIC



ANTI-KICKBACK AFFIDAVIT

STATE OF FLORIDA)
 : SS
COUNTY OF MONROE)

I, the undersigned hereby duly sworn, depose and say that no portion of the sum herein bid will be paid to any employees of the City of Key West as a commission, kickback, reward or gift, directly or indirectly by me or any member of my firm or by an officer of the corporation.

By: 

Sworn and subscribed before me this

16th day of May, 2011.

Gloria Mae Seyler
NOTARY PUBLIC, State of ~~Florida at Large~~ Virginia

My Commission Expires: 7-31-2013



**LOCAL VENDOR CERTIFICATION PURSUANT TO CKW ORDINANCE 09-22
SECTION 2-798**

The undersigned, as a duly authorized representative of the vendor listed herein, certifies to the best of his/her knowledge and belief, that the vendor meets the definition of a "Local Business." For purposes of this section, "local business" shall mean a business which:

- a. Principle address as registered with the FL Department of State located within 30 miles of the boundaries of the city, listed with the chief licensing official as having a business tax receipt with its principle address within 30 miles of the boundaries of the city for at least one year immediately prior to the issuance of the solicitation.
- b. Maintains a workforce of at least 50 percent of its employees from the city or within 30 miles of its boundaries.
- c. Having paid all current license taxes and any other fees due the city at least 24 hours prior to the publication of the call for bids or request for proposals.

- Not a local vendor pursuant to Ordinance 09-22 Section 2-798
- Qualifies as a local vendor pursuant to Ordinance 09-22 Section 2-798

If you qualify, please complete the following in support of the self certification & submit copies of your County and City business licenses. Failure to provide the information requested will result in denial of certification as a local business.

Business Name **Sea Port Marine Corporation**

Phone: **800-446-8056**

Current Local Address:
(P.O. Box numbers may not be used to establish status)

Fax: **757-436-1460**

Length of time at this address

[Signature]
Signature of Authorized Representative

5-16-11
Date

STATE OF Virginia
City COUNTY OF Chesapeake

The foregoing instrument was acknowledged before me this 16th day of May, 2011.
By Robert Carriker, of Sea Port Marine Corporation
(Name of officer or agent, title of officer or agent) Name of corporation acknowledging)
or has produced _____ as identification
(type of identification)

Gloria Mae Seyler
Signature of Notary

Print, Type or Stamp Name of Notary

_____ Title or Rank

Return Completed form with
Supporting documents to:
City of Key West Purchasing



Lighthouse

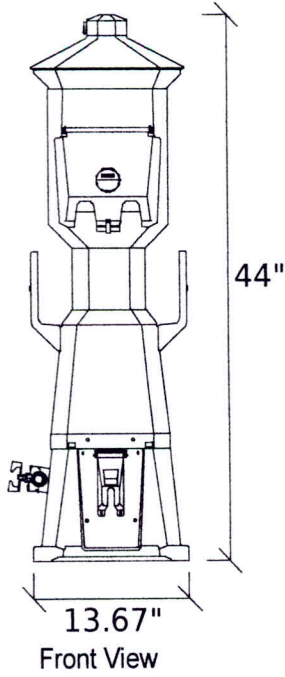
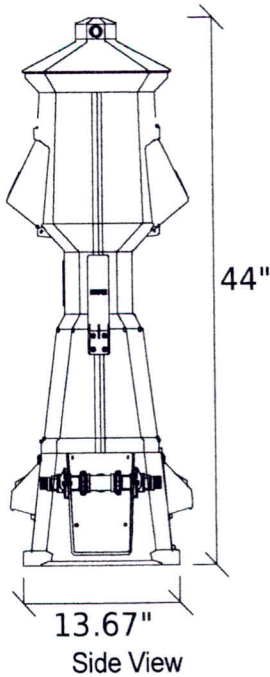

Metering
Unmetered
Bussing
Single Phase 3/8 in. Copper Bus Bar
Lighting
7 Watt Light
Lighting Protection
Breaker Protected
Lens Color
Amber

Side 1	Side 2
Receptacles	Receptacles
(1) 30A, 125V	(1) 30A, 125V
Hardwired Breakers	Hardwired Breakers
None	None
Extra Unmetered GFI	
None	

Communications
2 Phone Jack, 2 CATV
Water
2

Special Modifications

The information on this document is created by Eaton Corporation. It is disclosed in confidence and it is only to be used for the purpose in which it is supplied.

PREPARED BY KathleenDKullberg	DATE 05/10/11	Eaton Corporation	
APPROVED BY	DATE	JOB NAME Key West	DESIGNATION
VERSION 7.5		TYPE	DRAWING TYPE Customer Appr.
NEG-ALT NUMBER MPL50421F114-0000	REVISION	DWG SIZE A	G. O. ITEM
			SHEET 1 OF 2

Lighthouse

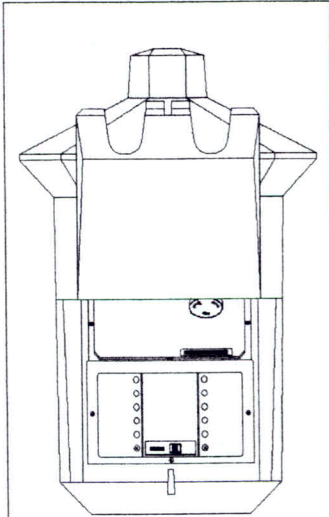

LH3000 30-blank

Side 1

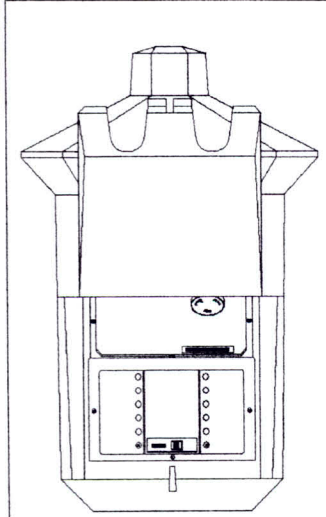

LH3000 30-blank

Side 2

Mounting Base & Dimensions

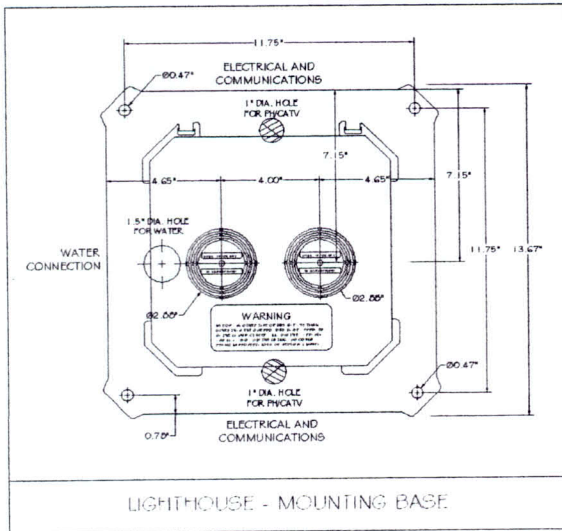

Bussing

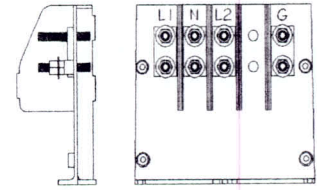

SINGLE PHASE - 3/8" STUD LUG

Communications

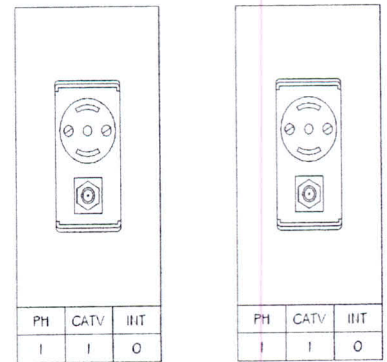

Water

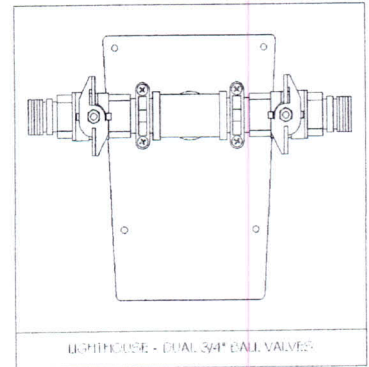

The information on this document is created by Eaton Corporation. It is disclosed in confidence and it is only to be used for the purpose in which it is supplied.

PREPARED BY
KathleenDKullberg

DATE
05/10/11

Eaton Corporation

APPROVED BY

DATE

JOB NAME
Key West

DESIGNATION

VERSION

7.5

TYPE

DRAWING TYPE

Customer Appr.

NEG-ALT NUMBER

MPL50421F114-0000

REVISION

DWG SIZE

A

G.O.

ITEM

SHEET

2 OF 2