

**PLANNING BOARD
RESOLUTION NO. 2015-13**

A RESOLUTION OF THE KEY WEST PLANNING BOARD GRANTING MAJOR DEVELOPMENT PLAN AND LANDSCAPE MODIFICATION / WAIVER APPROVALS PURSUANT TO SECTIONS 108-91.A.2.(B) AND 108-517 OF THE LAND DEVELOPMENT REGULATIONS OF THE CODE OF ORDINANCES OF THE CITY OF KEY WEST, FLORIDA FOR THE RECONSTRUCTION OF 12,153 SQUARE FEET OF NONRESIDENTIAL FLOOR AREA AS PART OF THE RENOVATION AND REPAIR OF THE FREDERICK DOUGLASS COMMUNITY CENTER AND FOR THE REDUCTION AND/OR WAIVER OF REQUIRED LANDSCAPING ON PROPERTY LOCATED AT 111 OLIVIA STREET (RE # 00014720-000000, AK #1015091) WITHIN THE HISTORIC NEIGHBORHOOD COMMERCIAL – BAHAMA VILLAGE (HNC-3) AND HISTORIC MEDIUM DENSITY RESIDENTIAL (HMDR) ZONING DISTRICTS; PROVIDING FOR AN EFFECTIVE DATE

WHEREAS, Section 108-91 of the Code of Ordinances (the “Code”) of the City of Key West, Florida (the “City”) provides that within the Historic District, a Major Development Plan is required for the reconstruction of greater than 2,500 square feet of nonresidential floor area; and

WHEREAS, modifications and waivers to reduce the City’s landscaping requirements are requested or required pursuant to City Code Section 108-517; and

WHEREAS, Code Sections 108-196(a) and 122-62(a) require the Planning Board to review and approve, approve with conditions or deny the proposed Major Development Plan in an advisory capacity to the City Commission; and

WHEREAS, Code Section 108-517(a) requires the Planning Board to consider the landscape modification / waiver request and render the final action; and

 Vice Chairman

 Planning Director

WHEREAS, this matter came before the Planning Board at a duly noticed public hearing on March 19, 2015; and

WHEREAS, the granting of a Major Development Plan and Landscape Modification / Waiver application is consistent with the criteria of the Code of Ordinances; and

WHEREAS, the Planning Board finds that the granting of a Major Development Plan and Landscape Modification / Waiver application is in harmony with the general purpose and intent of the Land Development Regulations, and will not be injurious to the neighborhood, or otherwise detrimental to the public welfare.

NOW, THEREFORE, BE IT RESOLVED by the Planning Board of the City of Key West, Florida:

Section 1. That the above recitals are incorporated by reference as if fully set forth herein.

Section 2. The Major Development Plan and Landscape Modification / Waiver for the reconstruction of greater than 2,500 square feet of nonresidential floor area as part of the renovation and repair of the Frederick Douglass Community Center on property located within the Historic Neighborhood Commercial (HNC-3) and Historic Medium Density Residential (HMDR) Zoning Districts pursuant to Section 108-91.A.2.(b) and 108-517 of the Land Development Regulations of the Code of Ordinances of the City of Key West, Florida, as shown in the attached plans, is hereby approved with the following conditions:

General conditions:



Vice Chairman



Planning Director

1. The proposed development shall be consistent with the site plan and architectural plans dated February 27, 2015 by architect Andrew M. Hayes. Notwithstanding the revisions requested and recommended by staff.

2. During all phases of demolition and construction, temporary fencing and erosion barriers shall be installed and maintained. All adjacent City streets and sidewalks shall be kept clean and clear of construction debris.

Conditions prior to the City Commission hearing:

3. The applicant shall submit a drainage plan pursuant to City Code Section 108-240 (1) (c).

4. The applicant shall submit a stormwater management plan pursuant to City Code Section 108-240 (2)

5. The applicant shall submit an irrigation plan pursuant to City Code Section 108-243(d)

6. The applicant shall submit an outdoor lighting plan pursuant to City Code Section 108-284.

Conditions prior to issuance of a building permit:

7. Approval of a Public Art Plan shall be obtained from the AIPP Board, pursuant to City Code Section 2-487, and may include payment of an in-lieu fee.

Conditions prior to issuance of a Certificate of Occupancy:

8. On-site artwork shall be installed and inspected by the City pursuant to Code

9. The property owner shall obtain and maintain a Conditional Approval Permit,

 Vice Chairman

 Planning Director

pursuant to City Code Chapter 18, Article XII, Division 1. The City Code Compliance shall inspect the property on an annual basis upon reasonable notice to determine compliance with the above conditions.

Section 3. Full, complete and final application for all permits required for which this resolution is wholly or partly necessary, shall be submitted in its entirety within 12 months after the date hereof.

Section 4. This Major Development Plan and Landscape Modification / Waiver application approval by the Planning Board does not constitute a finding as to ownership or right to possession of the property, and assumes, without finding, the correctness of the applicant's assertion of legal authority respecting the property.

Section 5. This resolution shall go into effect immediately upon its passage and adoption and authentication by the signatures of the presiding officer and the Clerk of the Board.

Section 6. This resolution is subject to appeal periods as provided by the City of Key West Code of Ordinances (including the Land Development Regulations). After the City appeal period has expired, this permit or development order shall be rendered to the Florida Department of Economic Opportunity. Pursuant to Chapter 73C-44, F.A.C., this permit or development order is not effective for 45 days after it has been properly rendered to the DEO with all exhibits and applications attached to or incorporated by reference in this approval; that within the 45-day review period, the DEO can appeal the permit or development order to the Florida Land and Water Adjudicatory Commission; and that such an appeal stays the effectiveness of the permit until the appeal is resolved by agreement or order.



Vice Chairman



Planning Director

Read and passed on first reading at a regularly scheduled meeting held this 19 day of March, 2015.

Authenticated by the Vice Chairman of the Planning Board and the Planning Director.

Sam Holland 4/16/15
Sam Holland, Planning Board Vice Chairman Date

Attest:

Kevin Bond 3/20/2015
Kevin Bond, AICP, Acting Planning Director Date

Filed with the Clerk:

Cheryl Smith 4-16-2015
Cheryl Smith, City Clerk Date

WHL Vice Chairman
KJB Planning Director

RENOVATION OF
**FREDERICK DOUGLASS
 RECREATION CENTER**

111 OLIVIA ST
 KEY WEST, FLORIDA 33040

50% CONSTRUCTION DOCUMENT SET - OWNER REVIEW

DEVELOPMENT TEAM

OWNER
 CITY OF KEY WEST
 111 OLIVIA STREET
 KEY WEST, FLORIDA 33040
 PH: 305.856.5444

ARCHITECT
 ANDREW M. HOYES, ARCHITECTS
 2200 S. UNIVERSITY AVENUE, SUITE 100
 MIAMI, FLORIDA 33136
 PH: 305.375.8377
 E: AHOYES@AMHARCHITECTS.COM

CONSULTANTS
MARCOVAL MACIELLI
 ARCHITECTURAL CONSULTANTS, INC.
 2200 S. UNIVERSITY AVENUE, SUITE 100
 MIAMI, FLORIDA 33136
 PH: 305.375.8377
 E: MACIELLI@MACIELLIARCHITECTS.COM

MECHANICAL, ELECTRICAL & PLUMBING ENGINEER
 M&E CONSULTANTS, INC.
 1800 N.W. 10TH AVENUE, SUITE 200
 MIAMI, FLORIDA 33136
 PH: 305.375.8377
 E: M&E@MECONSULTANTS.COM

MECHANICAL, ELECTRICAL & PLUMBING ENGINEER
 M&E CONSULTANTS, INC.
 1800 N.W. 10TH AVENUE, SUITE 200
 MIAMI, FLORIDA 33136
 PH: 305.375.8377
 E: M&E@MECONSULTANTS.COM

turnkey | committing
 turnkey.com
 5015 BENTLEY AVENUE, SUITE 100
 MIAMI BEACH, FLORIDA 33141
 PH: 772.331.0000
 FAX: 772.331.0003
 ANDREW@TURNKEY.COM
 PH: 305.331.0000

andrew.m.hoyes.architects@turnkey.com

MEMBER OF



ARCHITECTS

CONSULTANTS

CLIENT / PROJECT NAME:
 CITY OF KEY WEST
 ALTERATIONS TO

**FREDERICK DOUGLASS
 RECREATION CENTER**

111 OLIVIA STREET
 KEY WEST, FLORIDA

Original drawing by M&E, Inc. for the City of Key West, Florida

SHEET TITLE:
 COVER SHEET

REDUCTIONS:

DRAW NUMBER:
 PROJECT NO.

DRAWING NUMBER:
 G-001

SHEET 1 OF 18



AREA MAP
 OF KEY WEST



SITE MAP
 OF KEY WEST

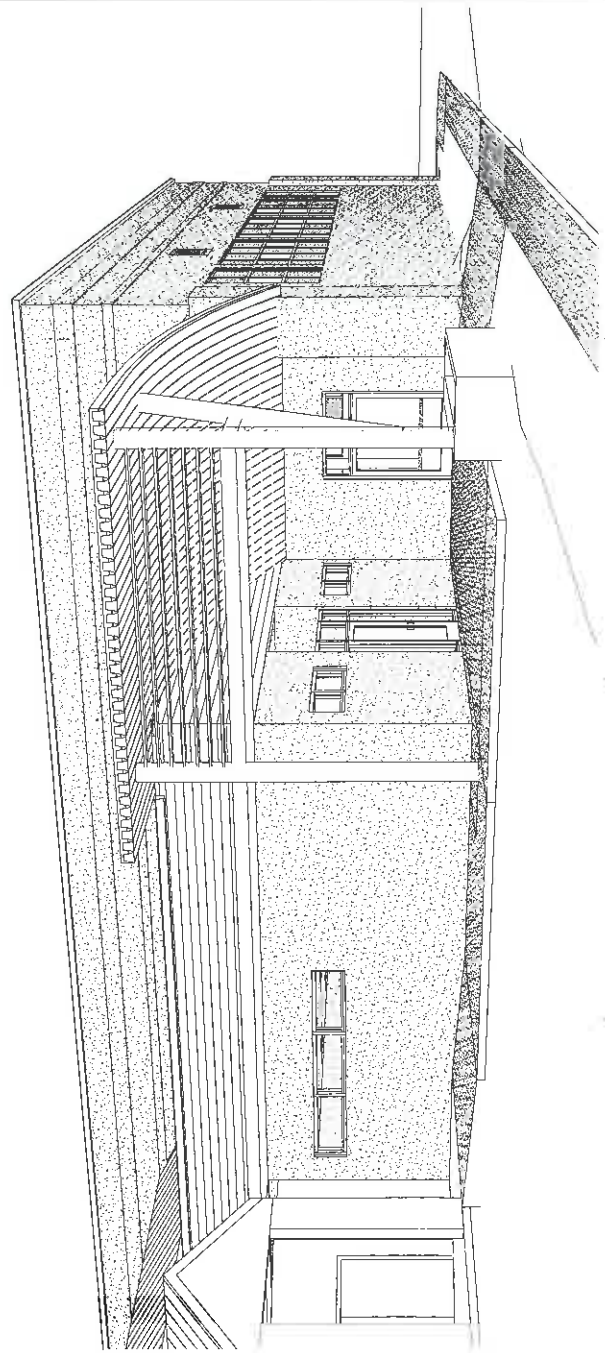

check KJB

CONTRACTOR
 2270 Conholave, Suite 100
 St. Petersburg, FL 33717
 Phone: 727-21-6999
 Fax: 727-21-6999
 h-p-g-c.com

Frederick Douglass
 Recreation Center



CONSULTANT

CLIENT / PROJECT NAME:
 CITY OF KEY WEST
 ALTERATIONS TO

**FREDERICK DOUGLASS
 RECREATION CENTER**

11000A0001
 11/10/2011
 11/10/2011

DATE: 11/10/2011
 PROJECT: 11000A0001
 SHEET: 1 OF 5

OCCUPANT LOAD BY CALCULATION

AREA	AREA (SQ. FT.)	USE	LOAD (PSF)	TOTAL LOAD (KIP)
ASSEMBLY A3	1082.7	ASSEMBLY	15	16.24
ASSEMBLY A3 STAGE	1123.9	ASSEMBLY	15	16.86
ASSEMBLY A3	1082.7	ASSEMBLY	15	16.24
ASSEMBLY A3	1082.7	ASSEMBLY	15	16.24
ASSEMBLY A3	1082.7	ASSEMBLY	15	16.24
ASSEMBLY A3	1082.7	ASSEMBLY	15	16.24
ASSEMBLY A3	1082.7	ASSEMBLY	15	16.24
ASSEMBLY A3	1082.7	ASSEMBLY	15	16.24
ASSEMBLY A3	1082.7	ASSEMBLY	15	16.24
ASSEMBLY A3	1082.7	ASSEMBLY	15	16.24

LIFE SAFETY SYMBOLS LEGEND

- CONCRETE FINISH FLOOR
- 1/2" HICKS IN REINFORCING PANEL WALL
- 2" X 4" JOIST FOR REINFORCING & BOND BOND
- 3" X 6" JOIST FOR REINFORCING & BOND BOND
- 4" X 8" JOIST FOR REINFORCING & BOND BOND
- 5" X 10" JOIST FOR REINFORCING & BOND BOND
- 6" X 12" JOIST FOR REINFORCING & BOND BOND
- 7" X 14" JOIST FOR REINFORCING & BOND BOND
- 8" X 16" JOIST FOR REINFORCING & BOND BOND
- 9" X 18" JOIST FOR REINFORCING & BOND BOND
- 10" X 20" JOIST FOR REINFORCING & BOND BOND
- 12" X 24" JOIST FOR REINFORCING & BOND BOND
- 14" X 28" JOIST FOR REINFORCING & BOND BOND
- 16" X 32" JOIST FOR REINFORCING & BOND BOND
- 18" X 36" JOIST FOR REINFORCING & BOND BOND
- 20" X 40" JOIST FOR REINFORCING & BOND BOND
- 22" X 44" JOIST FOR REINFORCING & BOND BOND
- 24" X 48" JOIST FOR REINFORCING & BOND BOND
- 26" X 52" JOIST FOR REINFORCING & BOND BOND
- 28" X 56" JOIST FOR REINFORCING & BOND BOND
- 30" X 60" JOIST FOR REINFORCING & BOND BOND
- 32" X 64" JOIST FOR REINFORCING & BOND BOND
- 34" X 68" JOIST FOR REINFORCING & BOND BOND
- 36" X 72" JOIST FOR REINFORCING & BOND BOND
- 38" X 76" JOIST FOR REINFORCING & BOND BOND
- 40" X 80" JOIST FOR REINFORCING & BOND BOND
- 42" X 84" JOIST FOR REINFORCING & BOND BOND
- 44" X 88" JOIST FOR REINFORCING & BOND BOND
- 46" X 92" JOIST FOR REINFORCING & BOND BOND
- 48" X 96" JOIST FOR REINFORCING & BOND BOND
- 50" X 100" JOIST FOR REINFORCING & BOND BOND
- 52" X 104" JOIST FOR REINFORCING & BOND BOND
- 54" X 108" JOIST FOR REINFORCING & BOND BOND
- 56" X 112" JOIST FOR REINFORCING & BOND BOND
- 58" X 116" JOIST FOR REINFORCING & BOND BOND
- 60" X 120" JOIST FOR REINFORCING & BOND BOND
- 62" X 124" JOIST FOR REINFORCING & BOND BOND
- 64" X 128" JOIST FOR REINFORCING & BOND BOND
- 66" X 132" JOIST FOR REINFORCING & BOND BOND
- 68" X 136" JOIST FOR REINFORCING & BOND BOND
- 70" X 140" JOIST FOR REINFORCING & BOND BOND
- 72" X 144" JOIST FOR REINFORCING & BOND BOND
- 74" X 148" JOIST FOR REINFORCING & BOND BOND
- 76" X 152" JOIST FOR REINFORCING & BOND BOND
- 78" X 156" JOIST FOR REINFORCING & BOND BOND
- 80" X 160" JOIST FOR REINFORCING & BOND BOND
- 82" X 164" JOIST FOR REINFORCING & BOND BOND
- 84" X 168" JOIST FOR REINFORCING & BOND BOND
- 86" X 172" JOIST FOR REINFORCING & BOND BOND
- 88" X 176" JOIST FOR REINFORCING & BOND BOND
- 90" X 180" JOIST FOR REINFORCING & BOND BOND
- 92" X 184" JOIST FOR REINFORCING & BOND BOND
- 94" X 188" JOIST FOR REINFORCING & BOND BOND
- 96" X 192" JOIST FOR REINFORCING & BOND BOND
- 98" X 196" JOIST FOR REINFORCING & BOND BOND
- 100" X 200" JOIST FOR REINFORCING & BOND BOND

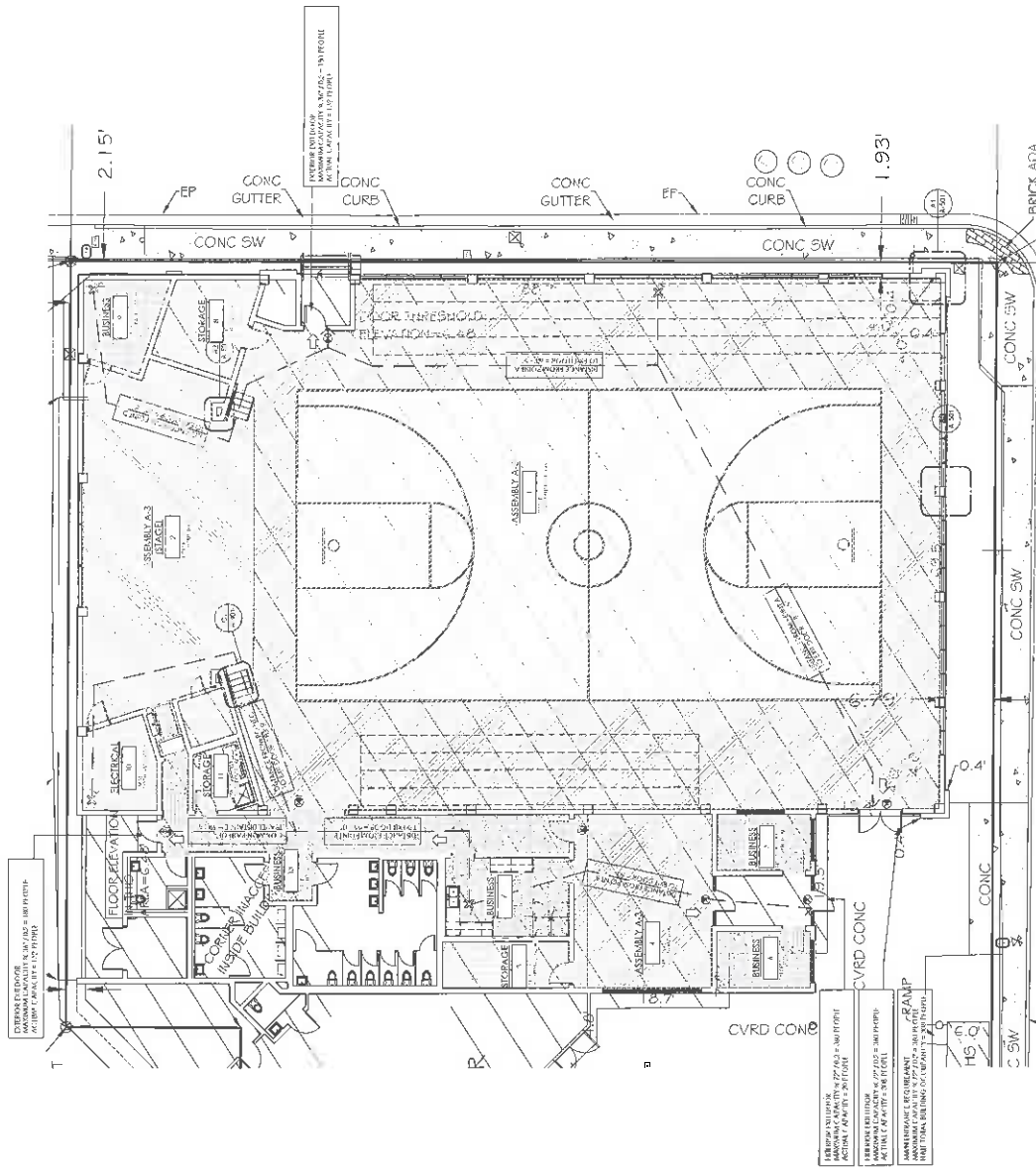

LIFE SAFETY PLAN - FIRST FLOOR
 11/10/2011

Handwritten notes:
 WAT
 KJS

2215 North West 100th Ave
 Ft. Lauderdale, FL 33311
 PH: 754.231.0993
 FAX: 754.231.0953
 WWW: WWW.HOK.COM

2000 W. W. Boylston Blvd. Suite 100
 Ft. Lauderdale, FL 33309

member of

ARCHITECT
 ARCHITECT

CONSULTANT:

CLIENT / PROJECT NAME
 CITY OF FORT WORTH
 ALTERATIONS TO

FREDERICK DOUGLASS
 RECREATION CENTER

1110 GORMAN STREET
 FORT WORTH, TEXAS

Original drawing's date: Scale accordingly - if required.

SHEET TITLE:

LANDSCAPE PLAN

REVISIONS:

DATE: 10/14/2014
 PROJECT NO.: 123001
 DRAWING NUMBER:

SYMBOL LEGEND

LANDSCAPE QUANTITY SPECIES



PLANT MATERIAL LIST

SYMBOL	QUANTITY	BOTANICAL NAME	COMMON NAME	SPECIFICATIONS	SPACING
CH	2	COCOLOBIA INVERSA	SEAMLESS TREE	10' HT. X 4" SPD. STANDARD	40' SPACING
CH	12	CARTHOXALANUS ICAGO	COCCORUM	24' HT. X 24" SPD. 5' GALLON	50' OC
CH	24	ZAMIA FLORIDANA	COONATIE	18' HT. X 18" SPD. 1' GALLON	50' OC
SR	6	BRIGNONIA BRIGNSA	SAN PALLETO	18' HT. X 18" SPD. 1' GALLON	50' OC
HE	52	MANEIA PATENS 'CORPACTA'	EMANIP PROSEBEN	24' HT. X 24" SPD. 5' GALLON	50' OC
HE	26	HYMENOCALLIS LAITICOLA	SPURER LILLY	18' HT. X 18" SPD. 5' GALLON	24' OC
IV	104	LEIDY 'SORELLING'S PRINCE'	EMANIP PALMOM RALLY	18' HT. X 18" SPD. 5' GALLON	50' OC
DR	45	DRACUNA 'WILD MARY'	WILD MARY'S DEBBER	18' HT. X 18" SPD. 5' GALLON	50' OC
EL	100	BRIDGIA LITTORALE	WILD MARY'S DEBBER	18' HT. X 18" SPD. 5' GALLON	24' OC
EL	20	PROSOPALUM TILICORUM	WILD MARY'S DEBBER	18' HT. X 18" SPD. 5' GALLON	24' OC

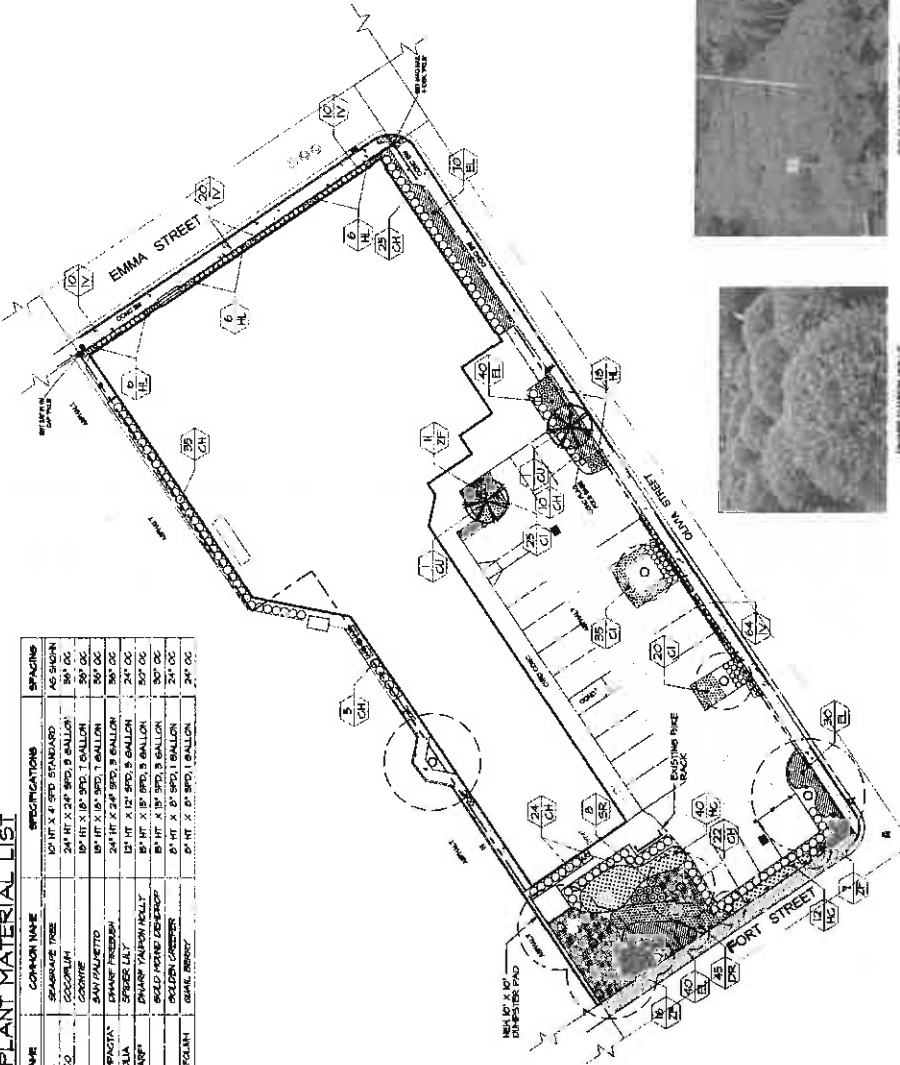

SPURER LILLY



EMANIP PROSEBEN



SAN PALLETO



COONATIE

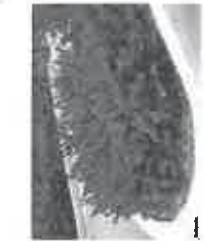

COCCORUM



EMANIP PALMOM RALLY



LANDSCAPE PLAN
 10/22/14

Handwritten notes in blue ink: 'CMB' and 'KJB'.

HOVELL PARTNERS
 ARCHITECTS
 2200 Central Expressway, Suite 100
 St. Petersburg, FL 33712
 P: 727.321.2000
 F: 727.321.0000
 M: 813.200.1340
 H: HOVELL.COM

DIVISION OF
ATA
 AMERICAN
 THREAT
 PREVENTION
 AUTHORITY

CLIENT / PROJECT NAME:
**FREDERICK DOUGLASS
 RECREATION CENTER**
 CITY OF KEY WEST
ALTERATIONS TO
 111 OLIVIA STREET
 KEY WEST, FL 34639

SHEET TITLE:
ARCHITECTURAL SITE PLAN
 REVISIONS:

DATE PLOTTED: 07/20/2016
 PLOTTED BY: J. TORRES
 PLOT SCALE: 1/8" = 1'-0"
A-001

SYMBOLS LEGEND

	STREET ADDRESS FOOTPRINT
	EXISTING FOUNDATION FOOTPRINT
	PROPOSED FOUNDATION FOOTPRINT
	NEW FOOTING
	EXISTING FOUNDATION
	NEW FOUNDATION
	EXISTING FOUNDATION
	EXISTING FOUNDATION
	EXISTING FOUNDATION

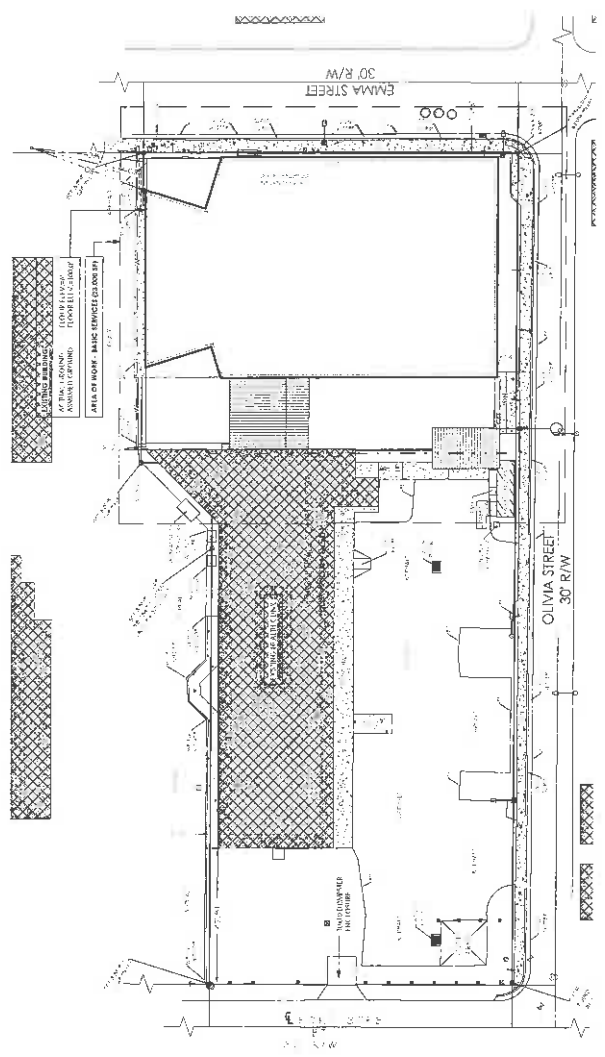

ARCHITECTURAL SITE PLAN
 NORTH

Case
 KJB



CONSULTANT:

CLIENT / PROJECT NAME:
CITY OF KEY WEST
ALTERATIONS TO

FREDERICK DOUGLASS RECREATION CENTER

111 PRIMA STREET
KEY WEST, FL 34290

DATE PLOTTED: 07/27/2011
PLOT TIME: 11:27:41 AM

SHEET TITLE:
SELECTIVE DEMOLITION PLAN

REVISIONS:

DATE PLOTTED: 07/27/2011
PLOT TIME: 11:27:41 AM

SHEET: 1 OF 5
A-002

Handwritten notes: *copy* and *RJS*

GENERAL DEMOLITION NOTES

1. REMOVE AND DISPOSE OF ALL EXISTING CONCRETE, BRICK, AND MASONRY WORK AS SHOWN ON THIS PLAN AND ALL OTHER PLANS AND SPECIFICATIONS.
2. REMOVE AND DISPOSE OF ALL EXISTING METAL ROOFING, FLASHING, AND GUTTERS AS SHOWN ON THIS PLAN AND ALL OTHER PLANS AND SPECIFICATIONS.
3. REMOVE AND DISPOSE OF ALL EXISTING MECHANICAL, ELECTRICAL, AND PLUMBING SYSTEMS AS SHOWN ON THIS PLAN AND ALL OTHER PLANS AND SPECIFICATIONS.
4. REMOVE AND DISPOSE OF ALL EXISTING INTERIORS AS SHOWN ON THIS PLAN AND ALL OTHER PLANS AND SPECIFICATIONS.
5. REMOVE AND DISPOSE OF ALL EXISTING PAINTS AND COATINGS AS SHOWN ON THIS PLAN AND ALL OTHER PLANS AND SPECIFICATIONS.

SELECTIVE DEMOLITION KEYNOTES

1. DEMOLISH ALL EXISTING WALLS AND ROOF IN THE AREA AREAS SHOWN ON THIS PLAN.
2. MAINTAIN EXISTING ROOF STRUCTURE.
3. MAINTAIN EXISTING FLOOR STRUCTURE.
4. MAINTAIN EXISTING EXTERIOR WALLS.
5. MAINTAIN EXISTING INTERIORS.

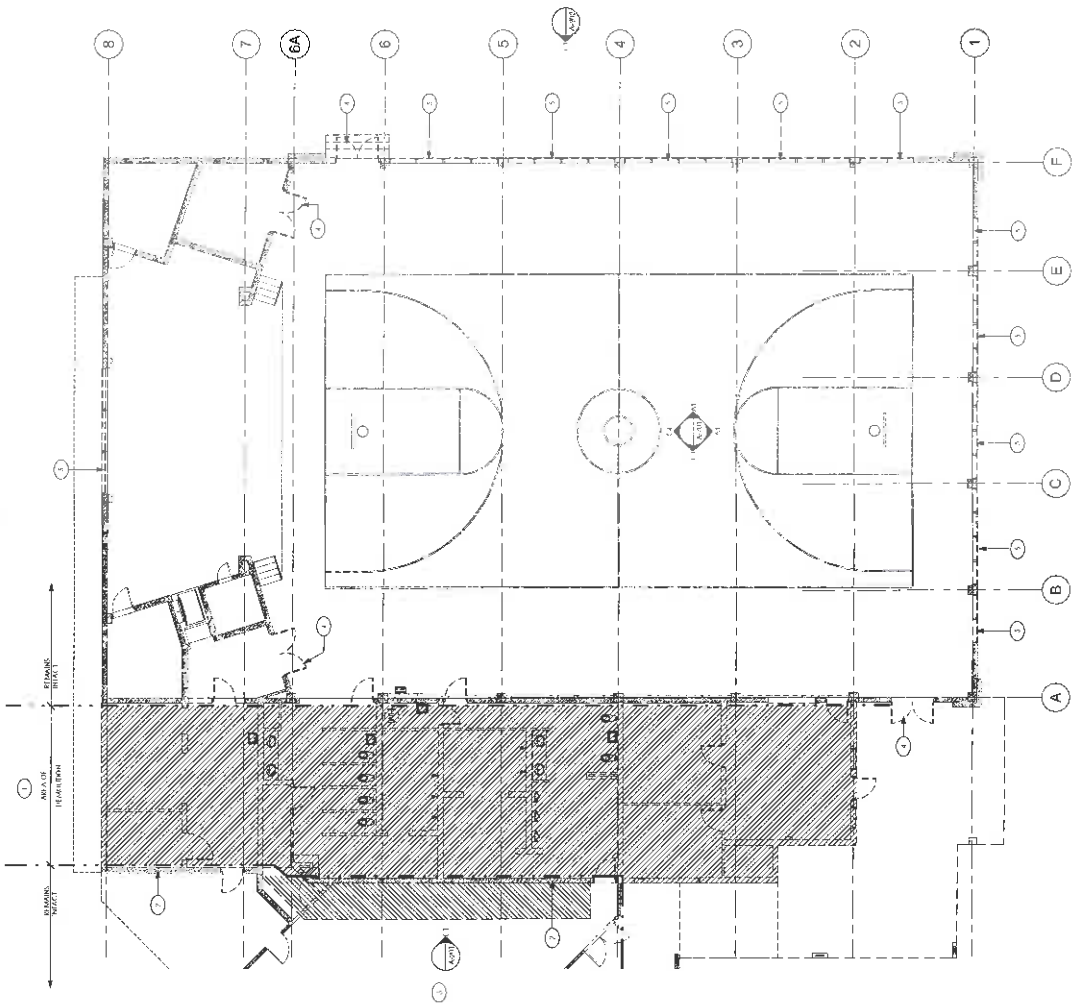

SELECTIVE DEMOLITION PLAN



1. SEE FINISH SCHEDULE FOR ALL FINISHES
 2. FINISHES TO BE APPLIED TO ALL SURFACES UNLESS NOTED OTHERWISE

1. SEE FINISH SCHEDULE FOR ALL FINISHES
 2. FINISHES TO BE APPLIED TO ALL SURFACES UNLESS NOTED OTHERWISE

ROOM FINISH SCHEDULE

ROOM	NO.	FINISH	WALL	CEILING	FLOOR	NOTES
101	OFFICE	101	101	101	101	
102	OFFICE	102	102	102	102	
103	OFFICE	103	103	103	103	
104	OFFICE	104	104	104	104	
105	OFFICE	105	105	105	105	
106	OFFICE	106	106	106	106	
107	OFFICE	107	107	107	107	
108	OFFICE	108	108	108	108	
109	OFFICE	109	109	109	109	
110	OFFICE	110	110	110	110	
111	OFFICE	111	111	111	111	
112	OFFICE	112	112	112	112	
113	OFFICE	113	113	113	113	
114	OFFICE	114	114	114	114	
115	OFFICE	115	115	115	115	
116	OFFICE	116	116	116	116	
117	OFFICE	117	117	117	117	
118	OFFICE	118	118	118	118	
119	OFFICE	119	119	119	119	
120	OFFICE	120	120	120	120	

MATERIAL AND FINISH CODE LIST

FINISH	DESCRIPTION
A	CONCRETE
B	PAINT
C	WOOD
D	GLASS
E	CEILING
F	FLOOR
G	WALL
H	CEILING
I	FLOOR
J	WALL
K	CEILING
L	FLOOR
M	WALL
N	CEILING
O	FLOOR
P	WALL
Q	CEILING
R	FLOOR
S	WALL
T	CEILING
U	FLOOR
V	WALL
W	CEILING
X	FLOOR
Y	WALL
Z	CEILING

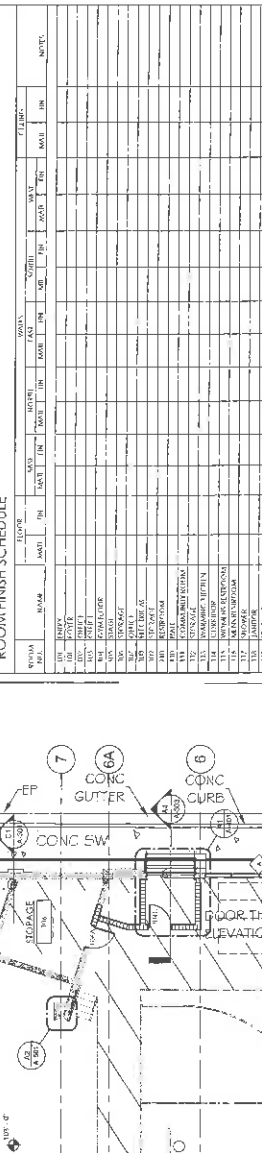

CLIENT / PROJECT NAME:
 CITY OF FREDERICK
ALTERATIONS TO:
 FREDERICK DOUGLASS
 RECREATION CENTER

DATE: 11/11/2011

PROJECT NUMBER: 200-001-11-001

DESIGNER: [Signature]

ARCHITECTURAL PLAN

REVISIONS:

DATE: 11/11/2011

SCALE: 1/8" = 1'-0"

SHEET: A-102 OF 102

Handwritten notes: "KFS" and "WSS" in blue ink.

SHEET KEYNOTES

CALL OUTS TO BE MATCHED TO THE
STANDARD DRAWING INFORMATION
SHEET (EP 220)

2210 Central Ave, Suite 100
St. Petersburg, FL 33712
Phone: (727) 321-5903
Fax: (727) 321-5903
AA22001-200
R-2-ENC 02/01



COMPANY

CITY OF ST. PETERSBURG
ALTERATIONS TO

FREDERICK DOUGLASS
RECREATION CENTER

DATE: 02/01/01
SHEET: 22 OF 27
A-104

CMS - KJB

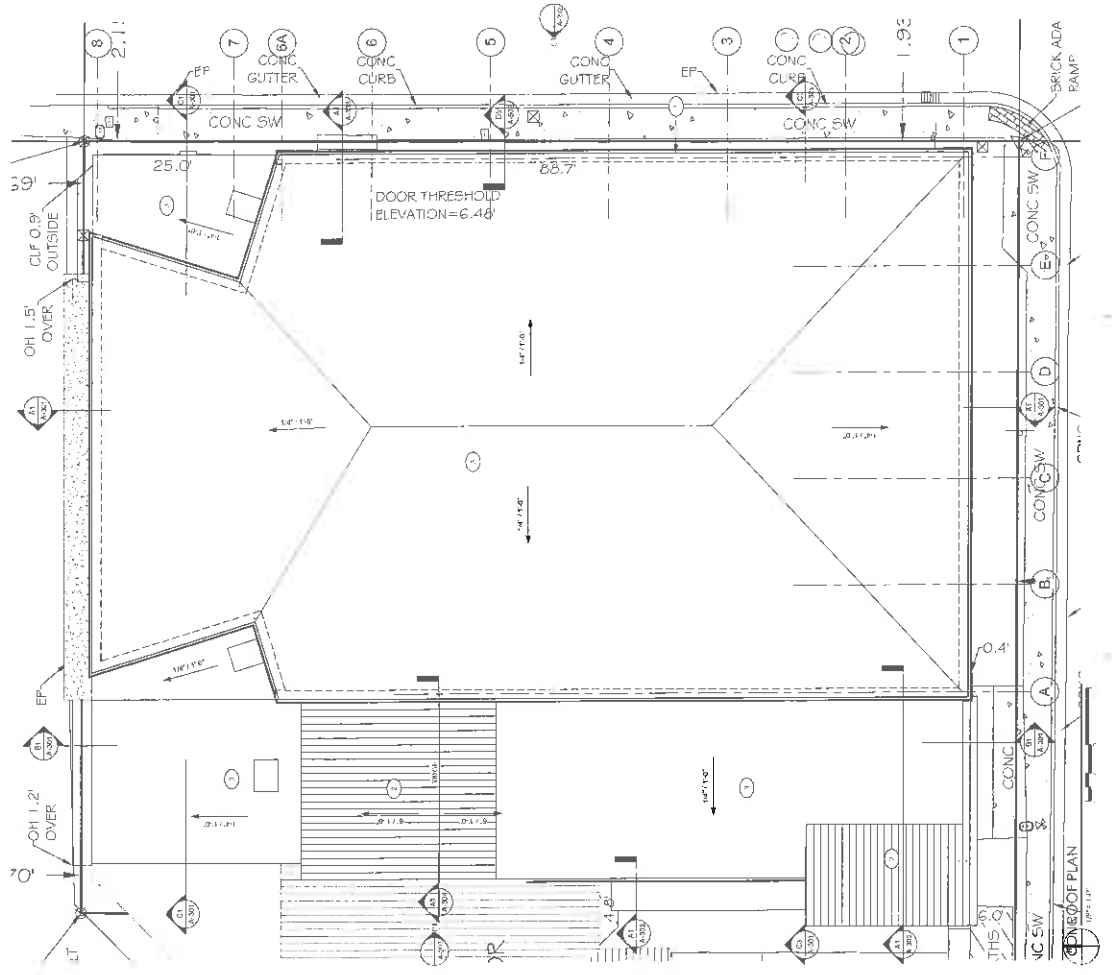

FLOOR PLAN



CONTRACTOR:

CLIENT / PROJECT NAME:
 CITY OF KEY WEST
 ALTERATIONS TO

FREDERICK DOUGLASS
 RECREATION CENTER

311 HOBAN BLVD
 ST. PETERSBURG, FL 33705

Original Issued: 05/14/14
 Date: 05/14/14

SHEET TITLE:

FURNITURE, FIXTURES & EQUIPMENT PLAN

REVISIONS:

DATE: 05/14/14
 DRAWN BY: J. HAYES
 CHECKED BY: J. HAYES

A-105

WAM KOB

EQUIPMENT SCHEDULE 'A' - FURNISHED & INSTALLED BY CONTRACTOR

NO.	DESCRIPTION	QTY	UNIT	REMARKS
1	RECYCLING BIN	1	EA	
2	STORAGE CABINET	1	EA	
3	STORAGE CABINET	1	EA	
4	STORAGE CABINET	1	EA	
5	STORAGE CABINET	1	EA	
6	STORAGE CABINET	1	EA	
7	STORAGE CABINET	1	EA	
8	STORAGE CABINET	1	EA	
9	STORAGE CABINET	1	EA	
10	STORAGE CABINET	1	EA	
11	STORAGE CABINET	1	EA	
12	STORAGE CABINET	1	EA	
13	STORAGE CABINET	1	EA	
14	STORAGE CABINET	1	EA	
15	STORAGE CABINET	1	EA	
16	STORAGE CABINET	1	EA	
17	STORAGE CABINET	1	EA	
18	STORAGE CABINET	1	EA	
19	STORAGE CABINET	1	EA	
20	STORAGE CABINET	1	EA	

EQUIPMENT SCHEDULE 'B' - FURNISHED BY OWNER & INSTALLED BY CONTRACTOR

NO.	DESCRIPTION	QTY	UNIT	REMARKS
1	CONC SW	1	EA	
2	CONC SW	1	EA	
3	CONC SW	1	EA	
4	CONC SW	1	EA	
5	CONC SW	1	EA	
6	CONC SW	1	EA	
7	CONC SW	1	EA	
8	CONC SW	1	EA	
9	CONC SW	1	EA	
10	CONC SW	1	EA	
11	CONC SW	1	EA	
12	CONC SW	1	EA	
13	CONC SW	1	EA	
14	CONC SW	1	EA	
15	CONC SW	1	EA	
16	CONC SW	1	EA	
17	CONC SW	1	EA	
18	CONC SW	1	EA	
19	CONC SW	1	EA	
20	CONC SW	1	EA	

EQUIPMENT SCHEDULE 'C' - FURNISHED BY OWNER & INSTALLED BY OWNER (OTHERS)

NO.	DESCRIPTION	QTY	UNIT	REMARKS
1	CONC SW	1	EA	
2	CONC SW	1	EA	
3	CONC SW	1	EA	
4	CONC SW	1	EA	
5	CONC SW	1	EA	
6	CONC SW	1	EA	
7	CONC SW	1	EA	
8	CONC SW	1	EA	
9	CONC SW	1	EA	
10	CONC SW	1	EA	
11	CONC SW	1	EA	
12	CONC SW	1	EA	
13	CONC SW	1	EA	
14	CONC SW	1	EA	
15	CONC SW	1	EA	
16	CONC SW	1	EA	
17	CONC SW	1	EA	
18	CONC SW	1	EA	
19	CONC SW	1	EA	
20	CONC SW	1	EA	

OWNER TO PROVIDE THE FOLLOWING: 1. ALL FURNITURE & EQUIPMENT TO BE LOCATED INTO THIS SPACE. 2. ALL FURNITURE & EQUIPMENT TO BE INSTALLED BY OWNER (OTHERS). 3. ALL FURNITURE & EQUIPMENT TO BE INSTALLED BY OWNER (OTHERS). 4. ALL FURNITURE & EQUIPMENT TO BE INSTALLED BY OWNER (OTHERS). 5. ALL FURNITURE & EQUIPMENT TO BE INSTALLED BY OWNER (OTHERS). 6. ALL FURNITURE & EQUIPMENT TO BE INSTALLED BY OWNER (OTHERS). 7. ALL FURNITURE & EQUIPMENT TO BE INSTALLED BY OWNER (OTHERS). 8. ALL FURNITURE & EQUIPMENT TO BE INSTALLED BY OWNER (OTHERS). 9. ALL FURNITURE & EQUIPMENT TO BE INSTALLED BY OWNER (OTHERS). 10. ALL FURNITURE & EQUIPMENT TO BE INSTALLED BY OWNER (OTHERS). 11. ALL FURNITURE & EQUIPMENT TO BE INSTALLED BY OWNER (OTHERS). 12. ALL FURNITURE & EQUIPMENT TO BE INSTALLED BY OWNER (OTHERS). 13. ALL FURNITURE & EQUIPMENT TO BE INSTALLED BY OWNER (OTHERS). 14. ALL FURNITURE & EQUIPMENT TO BE INSTALLED BY OWNER (OTHERS). 15. ALL FURNITURE & EQUIPMENT TO BE INSTALLED BY OWNER (OTHERS). 16. ALL FURNITURE & EQUIPMENT TO BE INSTALLED BY OWNER (OTHERS). 17. ALL FURNITURE & EQUIPMENT TO BE INSTALLED BY OWNER (OTHERS). 18. ALL FURNITURE & EQUIPMENT TO BE INSTALLED BY OWNER (OTHERS). 19. ALL FURNITURE & EQUIPMENT TO BE INSTALLED BY OWNER (OTHERS). 20. ALL FURNITURE & EQUIPMENT TO BE INSTALLED BY OWNER (OTHERS).

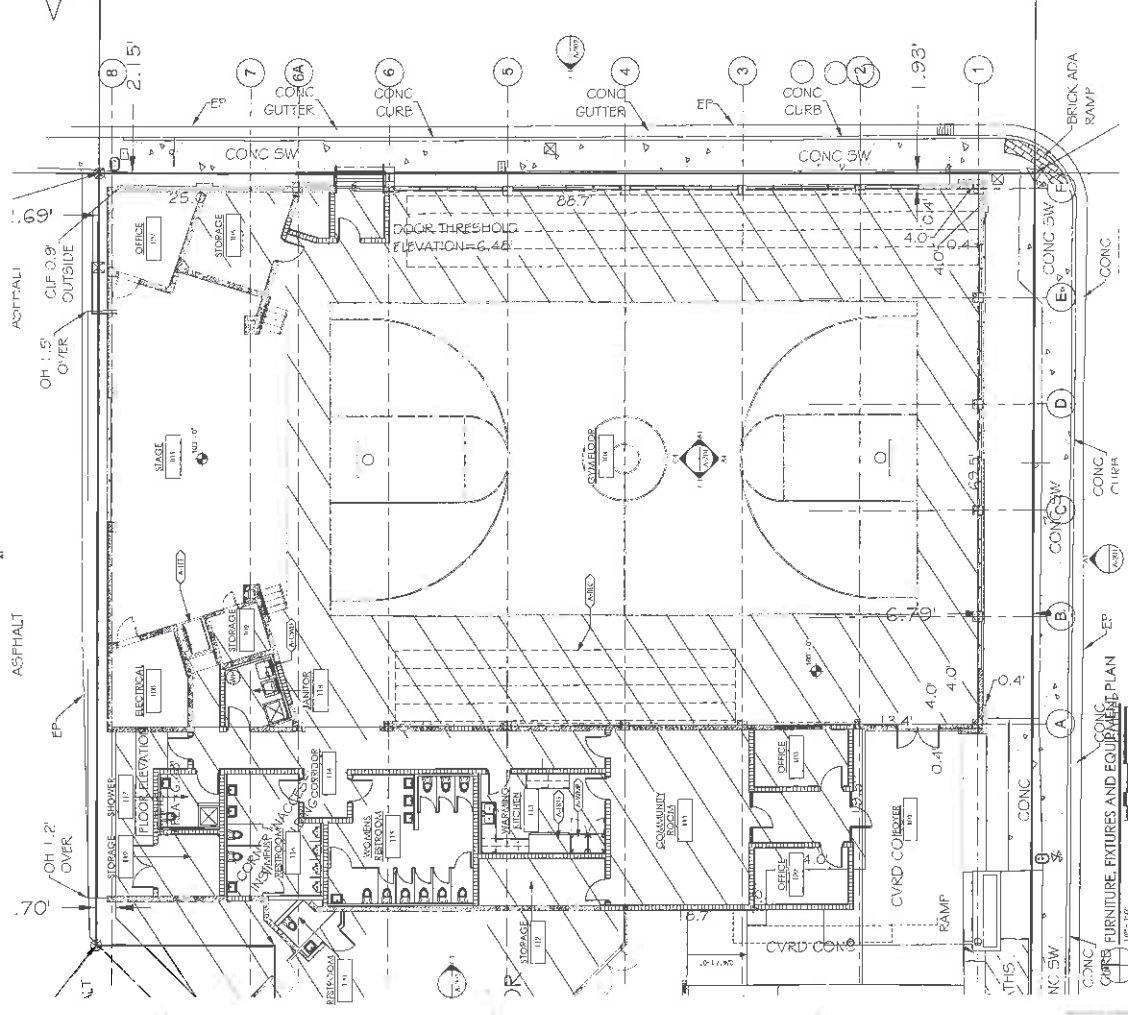

SHEET KEYNOTES

DATE: 01/15/14

2010 Central Ave., Suite 100
 Ft. Lauderdale, FL 33312
 Phone: 954.347.1000
 Fax: 954.347.1000
 AA 025007560
 H2 Engineering

AA 025007560

GOVERNOR, James M. Rubin, Governor

Member of



CC-HUNT/ANE

CLIENT / PROJECT NAME:
 CITY OF FORT WORTH
 ALTERATIONS TO

FREDERICK DOUGLASS
 RECREATION CENTER
 1111 MAIN STREET
 FORT WORTH, TX 76104

DATE: 01/15/14
 DRAWN BY: J. H. HARRIS
 CHECKED BY: J. H. HARRIS
 APPROVED BY: J. H. HARRIS

PROJECT NUMBER:
 A-201

SHEET 21 OF 27

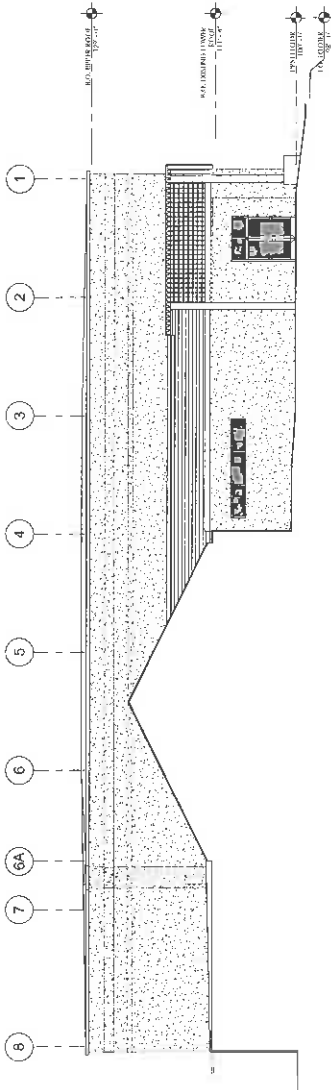

(C) WEST ELEVATION
 1/8" = 1'-0"

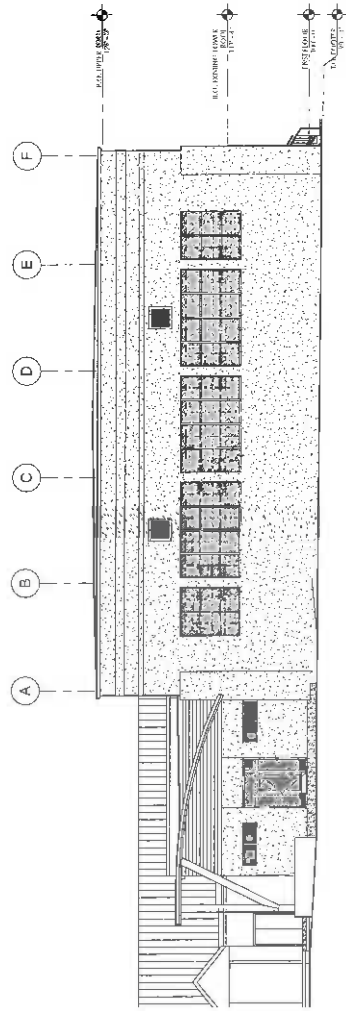

(A) SOUTH ELEVATION
 1/8" = 1'-0"

WLL KJB

SHEET KEYNOTES

Haynes | Cummings
 1000 ...
 1000 ...
 1000 ...

EXTERIOR FINISH MATERIAL LEGEND

1. FINISH MATERIALS
 (a) ...
 (b) ...
2. PERMANENT FIBER REINFORCED
 CONCRETE
 (a) ...
 (b) ...
 (c) ...
 (d) ...

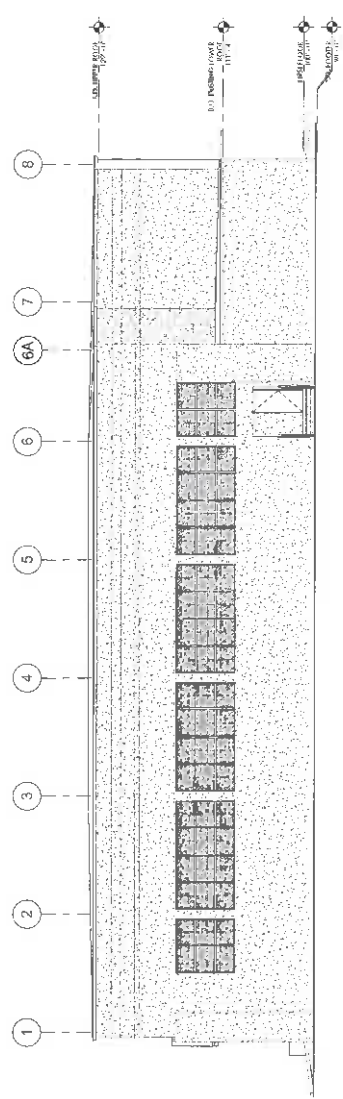

C1 EAST ELEVATION
 1/8" = 1'-0"

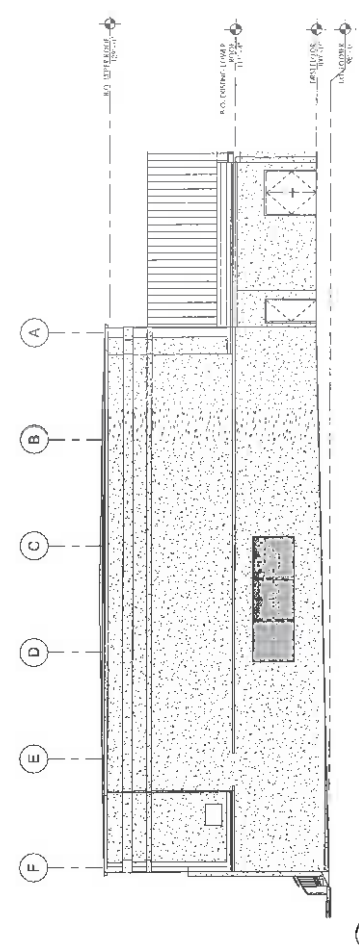

A1 NORTH ELEVATION
 1/8" = 1'-0"

ALTERNATIONS TO
 FREDERICK DOUGLASS
 RECREATION CENTER

WHL KAS



CONDOJANI:



CLIENT / PROJECT NAME:
CITY OF FREDERICK
ALTERATIONS TO

FREDERICK DOUGLASS
RECREATION CENTER

DATE: 01.21.20

DESIGNED BY: ROBERT TRITSA, P.E. & ANDREW HAYES, P.E.
SHEET TITLE:

MECHANICAL ROOF PLAN

REVISIONS:

SHEET NO. PROJECT NO. DRAWN BY

M-004

MECHANICAL ROOF PLAN
SCALE: 1/8"=1'-0"

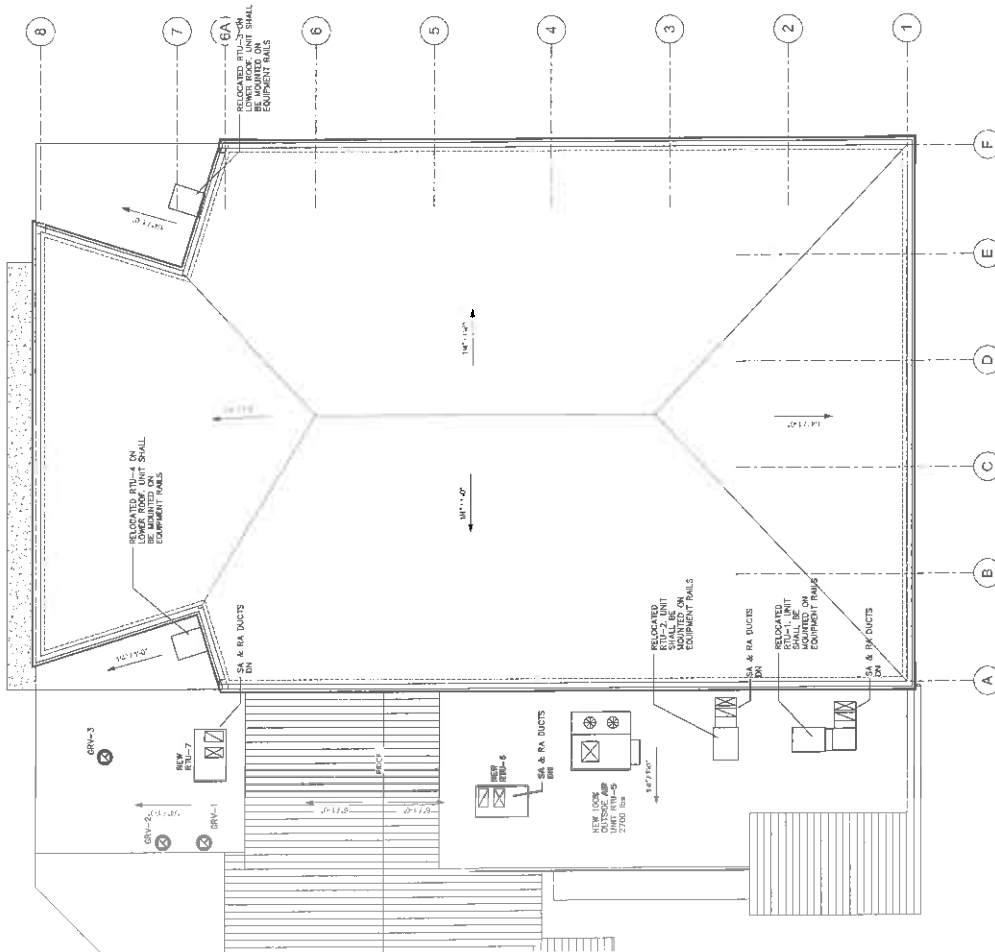

Handwritten blue notes: "CWA" and "KJB" with a signature.