

BID FORM

To: City of Key West, Florida
Address: 1300 White Street, Key West, Florida 33040
Project Title: **FREDERICK DOUGLASS COMMUNITY CENTER (FDCC)**
Project No.: ITB #23-005

Bidder's person to contact for additional information on this Bid:

Company Name: Keystar, Inc.

Contact Name & Telephone #: Charles Spottswood / 305-360-0802

Email Address: chas@keystarconstruction.com

BIDDER'S DECLARATION AND UNDERSTANDING

The undersigned, hereinafter called the Bidder, declares that the only persons or parties interested in this Bid are those named herein, that this Bid is, in all respects, fair and without fraud, that it is made without collusion with any official of the Owner, and that the Bid is made without any connection or collusion with any person submitting another Bid on this Contract.

The Bidder further declares that he/ she has carefully examined the Contract Documents, that he/ she has personally inspected the Project, that he/ she has satisfied himself/ herself as to the quantities involved, including materials and equipment, and conditions of work involved, including the fact that the description of the quantities of work and materials, as included herein, is brief and is intended only to indicate the general nature of the work and to identify the said quantities with the detailed requirements of the Contract Documents, and that this Bid is made according to the provisions and under the terms of the Contract Documents, which Documents are hereby made a part of this Proposal.

The Bidder further agrees that the Owner may “non-perform” the work in the event that the low bid is in excess of available funding. Non-performance will be determined prior to Notice of Award.

The intent of the Bid Documents is to describe a functionally complete project (or part thereof) to be constructed in accordance with the Contract Documents. Any work, materials, or equipment that may reasonably be inferred from the Contract Documents, as being required to produce the intended result shall be supplied, whether or not specifically called for in the Contract Documents.

GENERAL INSURANCE REQUIREMENTS

- 1.01 During the Term of the Agreement, the Contractor shall provide, pay for, and maintain with insurance companies satisfactory to the City of Key West, Florida (“City”), the types of insurance described herein.
- 1.02 All insurance shall be from responsible insurance companies eligible to do business in the State

of Florida. The required policies of insurance shall be performable in Monroe County, Florida, and shall be construed in accordance with the laws of the State of Florida.

- 1.03 The City shall be specifically included as an additional insured on the Contractor's Liability policies with the exception of the Contractor's Professional Liability policies (if required) and shall also provide the "Severability of Interest" provision (a/k/a "Separation of Insured's" provision). The City's additional insured status should be extended to all Completed Operations coverages.
- 1.04 The Contractor shall deliver to the City, prior to commencing work/activities under the Agreement, properly executed "Certificate(s) of Insurance" setting forth the insurance coverage and limits required herein. The Certificates must be signed by the authorized representative of the insurance company(s) shown on the Certificate of Insurance. In addition, certified, true, and exact copies of the insurance policies required herein shall be provided to the City, on a timely basis, if requested by the City.
- 1.05 If the Contractor fails to provide or maintain the insurance coverages required in this Agreement at any time during the Term of the Agreement and if the Contractor refuses or otherwise neglects to deliver the required Certificate(s) of Insurance signed by the authorized representative of the insurance company(s) to the City, the City may, at the City's sole discretion, terminate or suspend this Agreement and seize the amount of Contractor's performance bond, letter of credit, or other security acceptable to the City).
- 1.06 The Contractor shall take immediate steps to make up any impairment to any Aggregate Policy Limit upon notification of the impairment. If at any time the City requests a written statement from the insurance company(s) as to any impairment to the Aggregate Limit, the Contractor shall promptly authorize and have delivered such statement to the City.
- 1.07 The Contractor authorizes the City and/or its insurance consultant to confirm all information furnished to the City, as to its compliance with its Bonds and Insurance Requirements, with the Contractor's insurance agents, brokers, surety, and insurance carriers.
- 1.08 All insurance coverage of the Contractor shall be primary to any insurance or self-insurance program carried by the City. The City's insurance or self-insurance programs or coverage shall not be contributory with any insurance required of the Contractor in this Agreement.
- 1.09 The acceptance of delivery to the City of any Certificate of Insurance evidencing the insurance coverage and limits required in the Agreement does not constitute approval or agreement by the City that the insurance requirements in the Agreement have been met or that the insurance policies shown in the Certificates of Insurance are in compliance with the Agreement requirements.
- 1.10 No work/activity under this Agreement shall commence or continue unless and until the required Certificate(s) of Insurance are in effect and the written Notice to Proceed is issued by the City.
- 1.11 The insurance coverage and limits required of the Contractor under this Agreement are designed to meet the minimum requirements of the City. They are not designed as a recommended insurance program for the Contractor. The Contractor alone shall be responsible for the sufficiency of its own insurance program. Should the Contractor have any question concerning its exposures to loss under this Agreement or the possible insurance coverage needed therefore, it should seek professional assistance.
- 1.12 During the Term of this Agreement, the City and its agents and contractors may continue to

engage in necessary business activities during the operations of the Contractor. No personal property owned by City used in connection with these business activities shall be considered by the Contractor's insurance company as being in the care, custody, or control of the Contractor.

- 1.13 Should any of the required insurances specified in this Agreement provide for a deductible, self-insured retention, self-insured amount, or any scheme other than a fully insured program, the Contractor shall be responsible for all deductibles and self-insured retentions.
- 1.14 All of the required insurance coverages shall be issued as required by law and shall be endorsed, where necessary, to comply with the minimum requirements contained herein.
- 1.15 All policies of insurance required herein shall require that the insurer give the City thirty (30) days advance written notice of any cancellation, intent not to renew any policy and/or any change that will reduce the insurance coverage required in this Agreement, except for the application of the Aggregate Limits Provisions.
- 1.16 Renewal Certificate(s) of Insurance shall be provided to the City at least twenty (20) days prior to expiration of current coverage so that there shall be no termination of the Agreement due to lack of proof of the insurance coverage required of the Contractor.
- 1.17 If the Contractor utilizes contractors or sub-contractors to perform any operations or activities governed by this Agreement, the Contractor will ensure all contractors and sub-contractors to maintain the same types and amounts of insurance required of the Contractor. In addition, the Contractor will ensure that the contractor and sub-contractor insurances comply with all of the Insurance Requirements specified for the Contractor contained within this Agreement. The Contractor shall obtain Certificates of Insurance comparable to those required of the Contractor from all contractors and sub-contractors. Such Certificates of Insurances shall be presented to the City upon request. Contractor's obligation to ensure that all contractor's and sub-contractor's insurance as provided herein shall not exculpate Contractor from the direct primary responsibility Contractor has to the City hereunder. The City will look directly to Contractor for any such liability hereunder and shall not be obligated to seek recovery from any contractor or subcontractor or under such contractor's or sub-contractor's insurance coverages.

2.0 **SPECIFIC INSURANCE COVERAGES AND LIMITS:**

- 2.01 All requirements in this Insurance Section shall be complied with in full by the Contractor unless excused from compliance in writing by the City.
- 2.02 The amounts and types of insurance must conform to the following minimum requirements. Current Insurance Service Office (ISO) or National Council on Compensation Insurance (NCCI) policies, forms, and endorsements or broader shall be used where applicable. Notwithstanding the foregoing, the wording of all policies, forms, and endorsements must be acceptable to the City.

Workers' Compensation and Employers' Liability Insurance shall be maintained in force during the Term of this Agreement for all employees engaged in this work under this Agreement, in accordance with the laws of the State of Florida. The minimum acceptable limits shall be:

Workers' Compensation	Florida Statutory Requirements
Employer's Liability	\$1,000,000.00 Limit Each Accident
	\$1,000,000.00 Limit Disease Aggregate
	\$1,000,000.00 Limit Disease Each

Employee

If the Contractor has less than four (4) employees and has elected not to purchase Workers' Compensation/Employers Liability coverage as permitted by *Florida Statutes*, the Contractor will be required to issue a formal letter (on the Contractor's letterhead) stating that it has less than four (4) employees and has elected not to purchase Workers' Compensation/Employers Liability coverage as permitted by *Florida Statutes*. This exception does **not** apply to firms engaged in construction activities.

Commercial General Liability Insurance shall be maintained by the Contractor on a Full Occurrence Form. Coverage shall include, but not be limited to, Premises and Operations, Personal Injury, Contractual for this Agreement, Independent Contractors, and Products & Completed Operations Coverage. The limits of such coverage shall not be less than:

Bodily Injury & Property Damage Liability	\$2,000,000.00 Combined Single Limit each Occurrence and Aggregate
--	---

Completed Operations Liability Coverage shall be maintained by the Contractor for a period of not less than four (4) years following expiration or termination of this Agreement.

The use of an Excess, Umbrella and/or Bumbershoot policy shall be acceptable if the level of protection provided by the Excess, Umbrella and/or Bumbershoot policy is equal to or more comprehensive than the Primary Commercial General Liability policy.

Business Automobile Liability Insurance shall be maintained by the Contractor as to ownership, maintenance, use, loading and unloading of all owned, non-owned, leased, or hired vehicles with limits of such coverage of not less than:

Bodily Injury	\$1,000,000.00 Limit Each Accident
Property Damage Liability	\$1,000,000.00 Limit Each Accident

or

Bodily Injury & Property Damage Liability	\$1,000,000.00 Combined Single Limit Each Accident
--	--

If the Contractor does not own any vehicles, this requirement can be satisfied by having the Contractor's Commercial General Liability policy endorsed with "Non-Owned and Hired Automobile" Liability coverage.

Builders Risk Insurance shall be maintained by the Contractor. Coverage should be provided on an "All Risk" basis to include the perils of Flood and Wind. Coverage must extend to all materials stored at the construction site that is intended to be included in the completed structure. Coverage should be provided on a "Completed Value" basis. The minimum acceptable limits for this coverage shall the Full Replacement Value of the completed structure. **City shall be designated as the "Loss Payee" on the policy.**

SURETY AND INSURER QUALIFICATIONS

All bonds, insurance contracts, and certificates of insurance shall be either executed by or countersigned by a licensed resident agent of the Surety or insurance company, having his/ her place of business in the State of Florida, and in all ways complying with the insurance laws of the State of

Florida. Further, the said Surety or insurance company shall be duly licensed and qualified to do business in the State of Florida.

START OF CONSTRUCTION AND CONTRACT COMPLETION TIME

The Bidder agrees to begin work within fourteen (14) calendar days after the date of the Notice to Proceed and to fully complete all work under this contract within **four hundred forty (440) calendar days**, including construction of the foundation and assembly of the structure.

LIQUIDATED DAMAGES

In the event the Bidder is awarded the Contract and fails to complete the work within the time limit or extended time limit agreed upon, as more particularly set forth in the Contract Documents, liquidated damages shall be paid to the Owner at the rate of **\$500.00** per day for all work awarded until the work has been satisfactorily completed as provided by the Contract Documents. Sundays and legal holidays shall be excluded in determining days in default.

Owner will recover such liquidated damages by deducting the amount owed from the final payment or any retainage held by Owner.

ADDENDA

The Bidder hereby acknowledges that he/ she has received Addenda No's. 01, 02, 03, _____.
(Bidder shall insert No. of each Addendum received) and agrees that all addenda issued are hereby made part of the Contract Documents, and the Bidder further agrees that his/ her Bid(s) includes all impacts resulting from said addenda.

SALES AND USE TAXES

The Bidder agrees that all federal, state, and local sales and use taxes are included in the stated bid prices for the work.

LUMP SUM WORK ITEMS

The Proposal for the work is to be submitted on lump sum basis. All items required to complete the work specified but not included in the Proposal shall be considered incidental to those set forth in the Proposal. Payment to the Contractor will be made on work actually performed by the Contractor, as specified in the Contract Documents.

The Bidder further proposes to accept as full payment for the Work proposed herein, the amounts computed under the provisions of the Contract Documents and based on the following individual lump sum amounts. The Bidder agrees that the lump sum pricing include all allowances for overhead and profit for each type and unit of work called for in these Contract Documents.

* * * * *

BID SCHEDULE

FREDERICK DOUGLASS COMMUNITY CENTER (FDCC)

LUMP SUM BID

Bid prices stated in this proposal include all costs and expenses for labor, equipment, materials, disposal and contractor’s overhead and profit. Prices for the various work line items are intended to establish a total price for completing the project in its entirety. All work and incidental costs shall be included for payment under the several scheduled items of the overall contract, and no separate payment will be made therefore.

The Bidder shall submit a Schedule of Values with the Bid. It shall be broken down by trade and type of work and it shall be used as a basis for payment. The Bidder will be considered non-responsive if Schedule of Values is not included in the Bid package.

Contract Days (545) calendar days. Anticipated days to complete 395 calendar days.

1. Mobilization, General/Supp Conditions and Demobilization

a. Mobilization	1	each	\$ <u>239,577.84</u>
b. General/Supp. Conditions	1	each	\$ <u>431,240.10</u>
c. Demobilization	1	each	\$ <u>119,788.92</u>
1	LS	(10% of Construction Cost Max.)	\$ <u>790,606.86</u>

2. Payment and Performance Bonds

1	LS	\$ <u>63,484.00</u>
---	----	---------------------

3. Permit Fees (to be paid at cost)

1	LS	\$ <u>125,000.00</u>
---	----	----------------------

4. All materials to complete site work and landscape.

1	LS	\$ <u>919,754.00</u>
---	----	----------------------

5. Construction of the building (Includes all labor, equipment, & materials for a complete product)

1	LS	\$ <u>6,061,682.65</u>
---	----	------------------------

6. Utility Allowance (only to be used with owner’s written directive) \$ 25,000.00

TOTAL OF ALL EXTENDED LINE ITEMS LISTED ABOVE:

Total of lump sum items 1 – 6 \$ 7,985,927.86
Seven Million Nine Hundred Eighty Five Thousand Nine Hundred
Twenty Seven Dollars & Eighty Six Cents

(amount written in words)

BASE BID ADD OR DEDUCT ALTERNATES

NOTE: OWNER HAS THE RIGHT TO ACCEPT OR REJECT ANY, ALL, OR NO BID ALTERNATE ITEMS. THE TOTAL OF BASE BID PLUS THE SUM OF OWNER SELECTED BID ALTERNATES WILL BE A BASIS OF EVALUATING LOW BIDDER AND BASIS OF AWARD.

NOTE: THE TOTAL BID WILL BE THE BASIS OF EVALUATING LOW BIDDER AND BASIS OF AWARD

7. An ADD Alternate for the casework and storage labeled Alt 1 (Music Suite)

*Includes Practice 122, 123, 124, 125, 126, 127 full height casework
1 LS \$ 71,500

8. A Deduct Alternate for sound panels- Main Hall (101)

1 LS \$ (82,000)

9. A Deduct Alternate for the proposed generator and pad, including all connections associated with the generator.

1 LS \$ (106,000)

10. Add Alternate- Irrigation Design-Build / Cistern Design- Build

1 LS \$ 32,450

Please describe the type of cistern/ water storage solution(s) you are proposing for the project.

We are proposing two (2) each 1200 gallon poly above ground tanks. These would be fed from downspouts at either end of the building and would not be interconnected. Each system would include a ¾ hp pump, float switches, and associated electric. The system would supply water to an irrigation system while the tanks were full of water. When the water level reaches a level too low in the tank, the float switch would switch water for irrigation over to FKAA supplied water.

ADDITIONAL ADD ALTERNATES REQUESTED

11. An ADD Alternate for aluminum railings at the main stairs

1 LS

\$ (5,500)

12. An ADD Alternate for resinous matrix terrazzo in lieu of tile

1 LS

\$ 50,050

20. Add Alternate for Solar Power System

Design and construct a roof mounted solar power system to provide full electrical services for all loads for daily operation of the facility. (See Roof Plan A2.3.1)

See attached Datasheets for equipment
specific warranties, overall workmanship
warranty of 2 years on the project Years

			System Warranty	
a.	LS	Solar Panels- Main Hall Roof	<u>76.05</u> KW	\$ <u>215,247.03</u>
b.	LS	Solar Panels- Low Roof Olivia	<u>40.5</u> KW	\$ <u>132,518.78</u>
c.	LS	Solar Panels- Low Roof Fort St	<u>35</u> KW	\$ <u>115,364.82</u>
Total of lump sum items 20.a- 20.c				\$ <u>463,130.63</u>
d.	LS	Battery system for Main Hall		\$ <u>N/A, see below narrative</u>
e.	LS	Battery system for Low Roof Olivia		\$ <u>N/A, see below narrative</u>
f.	LS	Battery system for Low Roof Fort St		\$ <u>N/A, see below narrative</u>
Total of lump sum items 20.d- 20.f				\$ <u>N/A, see below narrative</u>
g.	LS	Main Hall Design-Build Electrical Upgrades		\$ <u>28,213.00</u>
h.	LS	Olivia Street Design-Build Electrical Upgrades		\$ <u>28,213.00</u>
i.	LS	Fort St. Design-Build Electrical Upgrades		\$ <u>28,213.00</u>
Total of lump sum items 20.g- 20.i				\$ <u>28,213.00</u> (one time electrical cost whether 1,2, or 3 arrays are selected)
Total of lump sum items 20.a- 20.i				\$ <u>491,343.63</u>



SOLAR ENERGY PROPOSAL

LIC# CVC56792



University of Miami



CONTENTS

- AGT Introduction
- Key Company Information
- Company
- Project Timeline & Safety
- Project Proposal
- Solar Layout & Production Model
- Financial Model
- Project Spec Sheets
- Dare To Compare
- Meet Our Team
- Solar Energy Services
- Solar Energy Solutions
- Maintenance & Warranty
- Client References & Awards
- Contract Terms & Conditions

INTRODUCTION

Every second, our sun produces enough energy to sustain Earth's needs for 500,000 years. How will you harness it?



Advanced Roofing, Inc. and Advanced Green Technologies are pleased to submit the following information for your consideration regarding the contractor selection on your solar photovoltaic project.

As one of the largest commercial solar energy Engineering, Procurement, and Construction (EPC) Firms and Roofing Contractors in the United States, the opportunity to work with your organizations on this project is incredibly exciting for everyone on our team.

We have completed more than 700 successful DESIGN-BUILD solar installations throughout the globe totaling over 350 megawatts of clean energy. Finished projects include Florida's largest privately owned, non-utility and non-governmental solar array for the Lockheed Martin Corporation, along with installations in the Northeast United States for organizations such as Toys R Us, JP Morgan, City Furniture and Konica Minolta.

Our world-class team consists of diverse backgrounds in General Construction, Electrical and Structural Engineering, Metal Fabrication, and Commercial Roofing to ensure we exceed the highest design, installation, and safety standards on your project.

We look forward to discussing this project with you in more detail. Should you require any further information or clarification, please do not hesitate to contact me directly, at 954-522-6868 ext.1060.

Sincerely,

Clinton A. Sockman

Clinton A. Sockman
Vice President

Advanced Green Technologies

KEY COMPANY INFORMATION



Company Legal Name

Advanced Green Technologies
1950 NW 22nd St.
Fort Lauderdale, FL 33311
www.agt.com

Corporation

Fed ID Number – 59-2360591
Type of business: Private S-Corporation
State of incorporation: Florida
Date of incorporation: October, 1983

Safety – Interstate EMR

2022: 0.63

Professional Licenses

Solar Contractor- License #CVC-56792
NABCEP #PV-101913-002781
Electrical Contractor- License #EC13006050
General Contractor- License #CGC-1521128
Roofing Contractor- License #CCC024413
Mechanical Contractor- License #CAC1818806

Bank

Synovus
2500 Weston Rd., Suite 300
Weston, Florida 33331

Surety

The Guarantee Company of North America, USA Surety Agent:
William Griffin
900 S. Pine Island Rd., Suite 210, Plantation, FL 33324
Capacity: 150MM Rooftop; 1BB Ground-mount

Insurance Agent

Frank H Furman, Inc.
1314 East Atlantic Blvd.
Pompano Beach, FL 33060
Gen Lib: \$2MM aggregate

Your Experience Matters Most!

In maintaining our "Commitment to Quality," Advanced Green Technologies would like to remind customers that your experience is what matters most to us. Your experience with our company at every touch point is very important - from initial contact to project close-out. For us, it's not just about completing your project on time and on budget. It's about making the entire process from bidding to completion headache and hassle-free for you, the customer. We think you should be informed, involved and in control from the start, and with more than 500 employees, multiple offices locations, and state of the art equipment- we've got you protected.

Toys "R" Us



COMPANY PHILOSOPHY

On Time, On Budget! We Are Advanced!

The Advanced Family of Companies was founded in 1983 and built from the ground up on our guiding principle of "Committed to Quality" and by doing what we say we are going to do every time, with no exceptions.

Today we are a diversified specialty construction company with annual revenues between \$100 and \$115 million dollars and primarily engaged in the Commercial/Governmental/Industrial Solar, Roofing, Electrical and HVAC businesses.

Headquartered in Fort Lauderdale, we have offices throughout the State of Florida and Northeast United States that enable us to provide our services nation-wide at a competitive cost structure.

Discover What Makes Us Advanced!

In-House Divisions

Our company has a strong belief that the best way to control the construction schedule and cost overruns is to self-perform the scope of work and own the required equipment as much as possible. As a result, we have the following in-house divisions to help us streamline your project: roll-off dumpsters, tower crane, strike and rigging, sheet metal fabrication, mechanical, electrical, fleet of telescoping and scissor lifts. We are fully prepared to mobilize all of our equipment to hold the construction schedule as required or to make up for lost time due to unexpected weather delays.

Advanced Technology

Our team uses cutting-edge project management software including Microsoft CRM, Spitfire, Microsoft Dynamics, and our proprietary solar asset management software, Advanced Access. All of our platforms are cloud-based, giving our clients project and construction management staff worldwide access to all project data at a moment's notice through traditional and mobile devices.

Project Financing

We work with many large and boutique finance firms to bring the best solution for your solar energy project including Power Purchase Agreements (PPA), leasing options, PACE Financing, and SREC brokerage. Our project management team has many years of experience in grant/incentive research, application submissions, as well as, assistance with all essential paperwork for your solar array installation. These value added services are provided at no expense to our customers.

Why Choose Us?



Experienced Team

350+ Megawatts Installed
Award Winning NABCEP
Certified NRCA RISE Solar
Professional



Protection Guaranteed

Low Safety EMR = .63
\$150 Million Bonding
\$14 Million GL Insurance
\$2 Million Captive Insurance



Advanced Technology

Advanced Access
Spitfire Project Management
Microsoft CRM
AGT Data Monitoring



Cresskill High School

SOLAR PROJECT TIMELINE

At Advanced Green Technologies, solar energy is our business. That's why we are committed to the precision and quality of every installation we perform. We can offer you a broad range of solar energy services and solutions to fit your needs, and we are certified by every major solar manufacturer to install the highest quality systems with the best warranties.

Once you begin a project with us, the work will continue along a path to your complete satisfaction. First, your needs are assessed, and a plan is developed to determine the necessary course of action and best practices. Then we will select the best products, followed by establishing a timeline of your project. At regular stages along the way, you are updated on the project and supplied with appropriate reports and photographs. Our proven workflow ensures communication and clarity with all parties involved.

Our goal is to make the process of installing solar easy and hassle free for you. Our experience continually improves from feasibility studies and product procurement to construction and project commissioning.

See our process map below to understand how we perform a project from start to finish.

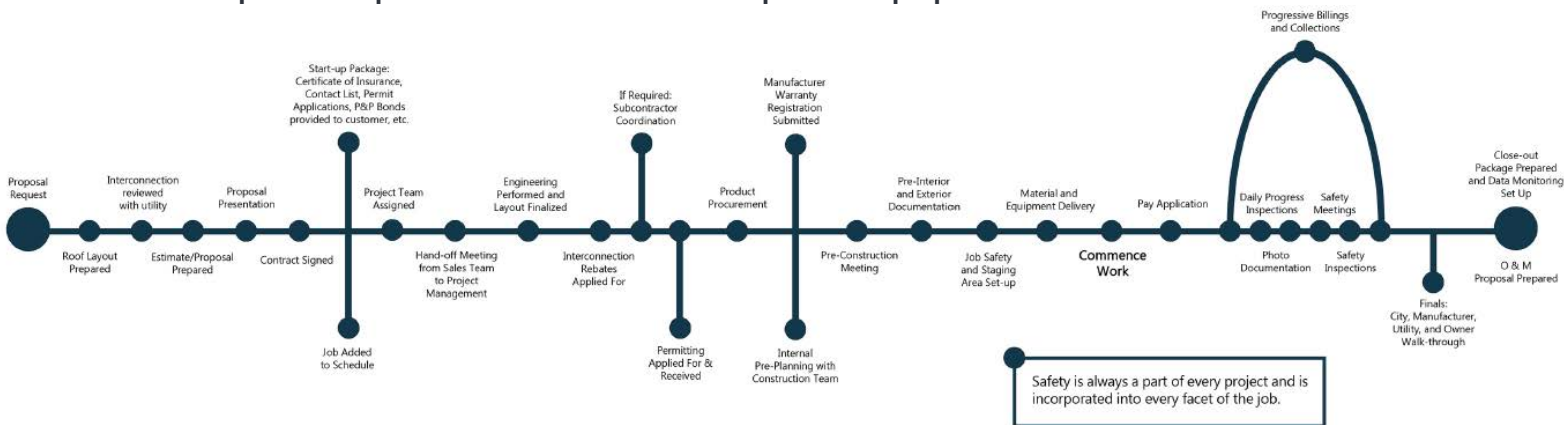

SAFETY IS OUR TOP PRIORITY

We are proud to be recognized as one of the safest construction companies in the solar industry with an Experience Modification Rate of 0.63 (1.0 = industry average).

Our team is committed to maintaining a safe and healthful workplace. By providing an environment that is free from recognized hazards we are able to protect our most valuable resource, our employees.

All Advanced projects have a detailed site-specific safety plan, kickoff meeting, and unannounced inspections to ensure our safety standards are exceeded.

Learn more about our safety program at www.agt.com



PROJECT PROPOSAL

Advanced Green Technologies (AGT) is pleased to submit the following proposal for your consideration of the above-referenced premises as follows. We agree to provide all labor, material, tools, equipment and proper insurance with an excess liability of twelve (12) million dollars.



To:

Jeremy Mosher
Keystar Construction
5450 MacDonald Avenue, Suite 3
Key West, Florida 33040
(786) 423-0864

Job Name:

Frederick Douglass Community Center

Address:

1300 White Street
Key West, Florida 33040

Date:

May 16, 2023

Reference:

Solar Portfolio Proposal

WORK SCOPE

PREPARATORY WORK – ROOFTOP

1. Design photovoltaic system in accordance with the manufacturer's specifications.
2. Provide string sizing, structural engineering, electrical engineering, and roof layout required for permitting.
3. Prepare roof surface to receive solar system and coordinate all warranty requirements with roofing manufacturer.
4. Secure and pay for all necessary local permits and approvals.
5. Secure and pay for all required Utility Net Metering and Interconnection agreements.
6. Provide and Install Roofing manufacturers flashing system at all required penetrations to ensure warranty continuation.

UNIRAC PHOTOVOLTAIC RACKING SYSTEM OR EQUIVALENT

Furnish and Install UNIRAC racking system ballasted and mechanically attached to the existing roof structure utilizing OMG PowerGrip products. Attachment of racking system to be engineered in accordance with local wind speed calculations in accordance with ASCE-16 guidelines, and local building code.

TALESUN TP6L72M 450W PHOTOVOLTAIC MODULES OR EQUIVALENT

Full Site: Furnish and install (337) Talesun TP6L72M 450W solar modules. A total of 151,650 kW to be installed.

Array 1: Furnish and install (78) Talesun TP6L72M 450W solar modules. A total of 35,100 kW to be installed.

Array 2: Furnish and install (90) Talesun TP6L72M 450W solar modules. A total of 40,500 kW to be installed.

Array 3: Furnish and install (169) Talesun TP6L72M 450W solar modules. A total of 76,050 kW to be installed.

APSMART RSD-S-PLC MODULE LEVEL RAPID SHUTDOWN DEVICES

Full Site: Furnish and Install (337) APsmart RSD-S-PLC rapid shutdown devices per final designs.

Array 1: Furnish and Install (78) APsmart RSD-S-PLC rapid shutdown devices per final designs.

Array 2: Furnish and Install (90) APsmart RSD-S-PLC rapid shutdown devices per final designs.

Array 3: Furnish and Install (169) APsmart RSD-S-PLC rapid shutdown devices per final designs.

CHINT POWER SYSTEMS SCA25KTL INVERTERS OR EQUIVALENT

Full Site: Furnish and Install (4) CPS SCA25KTL inverters per final designs.

Array 1: Furnish and Install (1) CPS SCA25KTL inverters per final designs.

Array 2: Furnish and Install (2) CPS SCA25KTL inverters per final designs.

Array 3: Furnish and Install (2) CPS SCA25KTL inverters per final designs.

AGT Project Proposal

ACCESSORIES

1. Furnish and install all wiring needed for installation. Exposed wiring will be housed in a wire management system and outdoor UV rated.
2. Furnish and install all DC/AC disconnects as required by engineering to be installed per wiring schematic.
3. Furnish and install all solar collection panels and tie into existing power distribution system.
4. Provide all wiring to Owner provided data lines for full Chint data monitoring system. Data lines are to be provided by the owner at the final location of inverters.

GUARANTEE

Twenty-Five (25) year limited guarantee on power output modules from Talesun or Equivalent.

GUARANTEE

Ten (10) year guarantee on inverters from Chint Power Systems or Equivalent.

GUARANTEE

Twenty-Five (25) year guarantee on rapid shutdown devices from APsmart or Equivalent.

WARRANTY

Two (2) year warranty on materials and labor from Advanced Roofing, Inc. dba Advanced Green Technologies

QUOTATION

Site Name	System Size (kW DC)	\$/W	Total Investment
Full Site	152	\$ 2.23	\$338,618.01
Site 1	35	\$ 2.99	\$104,877.11
Site 2	40.5	\$ 2.97	\$120,471.62
Site 3	76.05	\$ 2.57	\$195,679.12

Note: Prices do not reflect GC O&P (refer to bid form)

- c. Low Roof Fort St
- b. Low roof Olivia
- a. Main Hall Roof

CLARIFICATIONS & EXCLUSIONS

- Solar Energy is Sales Tax Exempt in the State of Florida
- Excludes Lightning Protection
- Excludes BAA/TAA Compliance
- Excludes Davis Bacon
- Excludes Fire Protection
- Excludes Payment & Performance Bond
- Excludes FM Global Requirements
- Excludes Module-Level Optimization
- Excludes Rapid Shutdown Devices and uses NEC 2020 code

AGT Project Proposal

Due to long lead time for material deliveries and extreme volatility in material prices, Contractor cannot guarantee the price of materials necessary for the completion of the Work. If, subsequent to the execution of this Agreement, there are any unavoidable casualties, material shortages, manufacturer or supplier mandated upcharges on materials, or any other events beyond Contractor's control that cause an increase in the price of the materials used in the performance of the Work, which include but is not limited to, steel, aluminum, cooper, steel-related products, or inverters or other electrical components, the Contract Sum shall be equitably adjusted to account for those unforeseen costs.

Steel Pricing is indexed to the FRED Index for "Hot Rolled Steel bars, plates and structural shapes" as well as for Cold Rolled sheet and strip. If cost increased more than 5% from the date of the quote and the time of ownership approval for release on these indexes, we reserve the right to increase the price according to the % increase cited in these indexes.

<https://fred.stlouisfed.org/series/WPU101704>
<https://fred.stlouisfed.org/series/PCU3312213312211>

Copper and Aluminum Electrical Wire and Cable is indexed to the FRED Index for "Copper Wire and Cable "and "Aluminum Wire and Cable. If cost increased more than 5% from the date of the quote and the time of ownership approval for release on these indexes, we reserve the right to increase the price according to the % increase cited in these indexes.

<https://fred.stlouisfed.org/series/WPU10260314>
<https://fred.stlouisfed.org/series/WPU10260331>

Owner/Customer acknowledges and agrees that this is a design-build contract and that the estimate of the cost of the Work is predicated on a schematic design. Accordingly, the quoted price for the cost of labor and material may change as the design is finalized. Further, In an effort to mitigate future price escalations, Contractor shall require, and Owner/Customer agrees to pay, a deposit of twenty-five percent (25%) of the Contract Sum within ten (10) days of execution of this Agreement. Contractor acknowledges and agrees that the deposit shall be used exclusively for the purchase of modules that are anticipated to be used for the Work.

Payment Terms:

- A. 25% deposit due within ten (10) days of execution of contract;
- B. Monthly progress payments per AIA 702 and 703 Schedule of Values;
- C. 10% retainage to be paid upon delivery of permit final, warranties, and Final Releases of Lien.

FINANCIAL MODELING

All financial modeling is for illustrative purposes only. AGT recommends consulting your tax attorney/advisor. Please review inputs closely for accuracy. If project specific corporate tax rate, utility billing details, and utility escalation rates were not provided; assumptions were likely made in the preparation of your proposal. Contact your sales representative to discuss the inputs required to prepare the most accurate financial model for your situation. It is also advisable that you review these assumptions when evaluating each bid received if project specific inputs were not provided to all bidders.

AGT Project Proposal

This quote is based on preliminary electrical design, if however final electrical design differs in installed wattage due to site or module size availability, the difference will be calculated at a per watt price.

All material is guaranteed to be as specified. All work to be completed in a workmanlike manner according to standard practices. Any alteration or deviation from above specifications involving extra costs will be executed only upon written order and will become an extra charge over and above the estimate. All agreements contingent upon strikes, accidents, or delays beyond our control. Owner to carry fire, tornado, and other necessary insurance.

Authorized Signature: Tom Griffith

Tom Griffith, Sales Executive

NOTE: This proposal may be withdrawn by us if not accepted within Seven (7) days.
Owner is responsible for asbestos testing and related cost to remove.

Acceptance of Proposal

The undersigned as (check one) Owner Authorized agent of Owner hereby accepts and agrees to the prices, specifications and conditions indicated above and on the reverse side of this contract.

Accepted: Signature:

Date: Signature:

*Terms & Conditions on last page(s) apply.

State License: CV-C56792

PM PROPOSAL

Advanced Green Technologies (AGT) is pleased to submit the following proposal for your consideration of the above-referenced premises as follows. We agree to provide all labor, material, tools, equipment and proper insurance with an excess liability of twelve (12) million dollars.



To:

Jeremy Mosher
Keystar Construction
5450 MacDonald Avenue, Suite 3
Key West, Florida 33040
(786) 423-0864

Job Name:

Frederick Douglass Community Center – Array 1

Address:

1300 White Street
Key West, Florida 33040

Date:

May 16, 2023

Reference:

Preventive Maintenance Proposal – 35.1 kW

DESCRIPTION OF ISSUE

We are pleased to submit the following two-year maintenance proposal (once a year visits) for your consideration on the above referenced location as follows:

SCOPE OF WORK**Inverter Maintenance/Module Inspections:**

- Check Irradiance and Module Temperature
- Check Operating Voltage (AC and DC Voltage) and Current
- Check Inverter status, Inspect inverter cabinet for damage and proper securement.
- Check Filters and clean as needed.
- Check inverter fans for dirt/dust build-up, clean and verify fans are operating properly.
- Measure torque of all electrical connections, re-torque as needed.
- Inspect all conduits for proper connections to supports, couplings and fittings.
- Inspect all visible wire connections to ensure all are properly secured.
- Inspect signs and labels and add or replace as needed.
- Inspect all racking and attachment systems for loose or missing parts. Repair or replace as needed.
- Visually inspect all PV Modules for physical damage and document conditions.
- Confirm no water leakage to any component parts.
- Remove and dispose of any debris covering the modules that may cause shading.
- *A complete documented report will be provided to the client digitally.

EXCLUSIONS

Excludes Lift, if needed.

This is a maintenance proposal only and does not cover labor or parts associated with potential repairs not covered under warranty. Work is based only on Scope of Work listed above, any other issues or problems will be identified, and the responsible party notified.

AGT will make necessary repairs as required after advising the Client of recommended repairs, providing a proposal, and executing scope of work once proposal is approved.

AGT Project Proposal

WARRANTY

Established warranty as stated in original contract agreement.

QUOTATION

Inverter Maintenance/Module Inspections:

FOR THE SUM OF:\$850.00
(Eight Hundred Fifty Dollars)

QUOTATION

Communications and Annual Reporting:

FOR THE SUM OF:\$1,200.00
(One Thousand Two Hundred Dollars)

ANNUAL MAINTENANCE SCHEDULE	
	COSTS
Annual Maintenance: Year 1 - 3	\$2,050.00 (per year)
Annual Maintenance: Year 4 - 6	TBD
Annual Maintenance: Year 7 - 9	TBD
Hourly T&M Rate for Non-O&M Work (2-Man Team)	\$200.00
Travel charges are billed portal to portal at the hourly rate	

All material is guaranteed to be as specified. All work to be completed in a workmanlike manner according to standard practices. Any alteration or deviation from above specifications involving extra costs will be executed only upon written order and will become an extra charge over and above the estimate. All agreements contingent upon strikes, accidents, or delays beyond our control. Owner to carry fire, tornado, and other necessary insurance.

This quote is based on preliminary electrical design, if however final electrical design differs in installed wattage due to site or module size availability, the difference will be calculated at a per watt price.

All material is guaranteed to be as specified. All work to be completed in a workmanlike manner according to standard practices. Any alteration or deviation from above specifications involving extra costs will be executed only upon written order and will become an extra charge over and above the estimate. All agreements contingent upon strikes, accidents, or delays beyond our control. Owner to carry fire, tornado, and other necessary insurance.

Authorized Signature: Tom Griffith
Tom Griffith, Sales Executive

NOTE: This proposal may be withdrawn by us if not accepted within Thirty (30) days.
Owner is responsible for asbestos testing and related cost to remove.

Acceptance of Proposal

The undersigned as (check one) Owner Authorized agent of Owner hereby accepts and agrees to the prices, specifications and conditions indicated above and on the reverse side of this contract.

Accepted: Signature:

Date: Signature:

*Terms & Conditions on last page(s) apply.

State License: CV-C56792

Array C. Low Roof Fort Street

Design 1 - Array 1 Frederick Douglass, 111Olivia Street Key West FL 33040

Report

Project Name	Frederick Douglass
Project Address	111Olivia Street Key West FL 33040
Prepared By	clinton sockman clints@agt.com



System Metrics

Design	Design 1 - Array 1
Module DC Nameplate	35.1 kW
Inverter AC Nameplate	25.0 kW Load Ratio: 1.40
Annual Production	58.33 MWh
Performance Ratio	80.2%
kWh/kWp	1,661.9
Weather Dataset	TMY, 10km Grid (24.55,-81.85), NREL (prospector)
Simulator Version	bea0c32975-f7c166ba04-e5790ed422-e085315a86

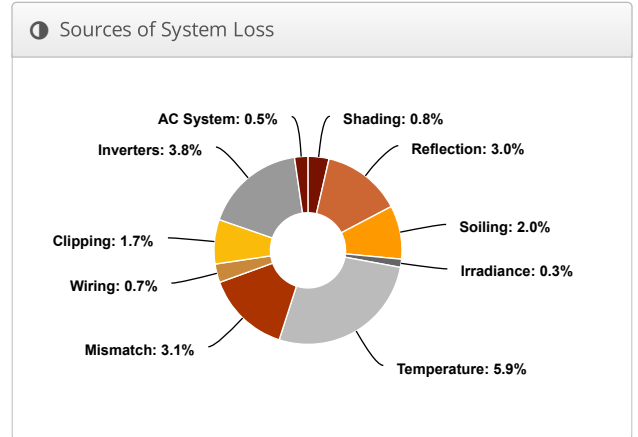
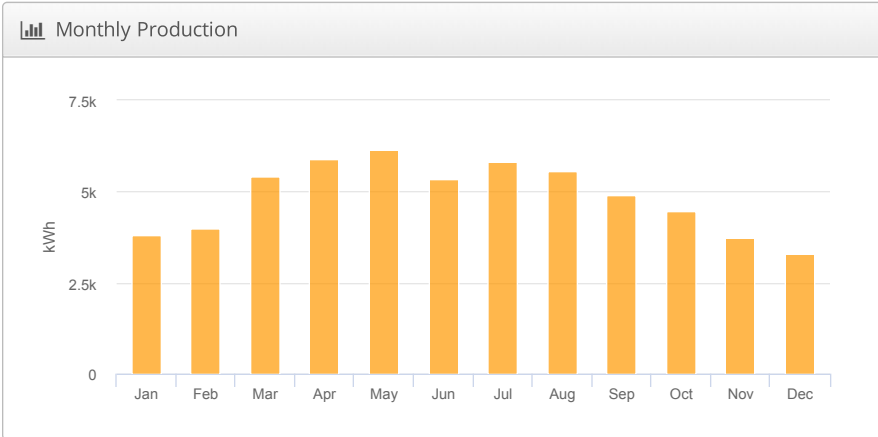
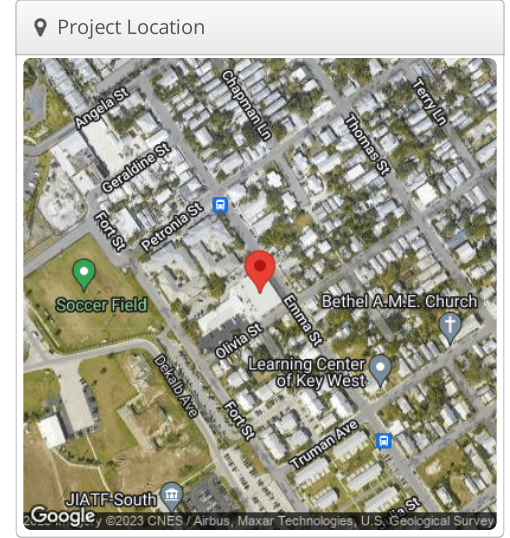

⚡ Annual Production			
	Description	Output	% Delta
Irradiance (kWh/m ²)	Annual Global Horizontal Irradiance	2,047.1	
	POA Irradiance	2,071.1	1.2%
	Shaded Irradiance	2,054.9	-0.8%
	Irradiance after Reflection	1,993.9	-3.0%
	Irradiance after Soiling	1,954.0	-2.0%
	Total Collector Irradiance	1,954.0	0.0%
Energy (kWh)	Nameplate	68,632.3	
	Output at Irradiance Levels	68,424.4	-0.3%
	Output at Cell Temperature Derate	64,408.5	-5.9%
	Output After Mismatch	62,382.5	-3.1%
	Optimal DC Output	61,950.2	-0.7%
	Constrained DC Output	60,922.5	-1.7%
	Inverter Output	58,624.9	-3.8%
	Energy to Grid	58,331.8	-0.5%
Temperature Metrics			
	Avg. Operating Ambient Temp	25.5 °C	
	Avg. Operating Cell Temp	35.3 °C	
Simulation Metrics			
	Operating Hours	4660	
	Solved Hours	4660	

☁ Condition Set												
Description	Condition Set 1											
Weather Dataset	TMY, 10km Grid (24.55,-81.85), NREL (prospector)											
Solar Angle Location	Meteo Lat/Lng											
Transposition Model	Perez Model											
Temperature Model	Sandia Model											
Temperature Model Parameters	Rack Type	a	b	Temperature Delta								
	Fixed Tilt	-3.56	-0.075	3°C								
	Flush Mount	-2.81	-0.0455	0°C								
	East-West	-3.56	-0.075	3°C								
	Carport	-3.56	-0.075	3°C								
Soiling (%)	J	F	M	A	M	J	J	A	S	O	N	D
	2	2	2	2	2	2	2	2	2	2	2	2
Irradiation Variance	5%											
Cell Temperature Spread	4° C											
Module Binning Range	-2.5% to 2.5%											
AC System Derate	0.50%											
Module Characterizations	Module						Uploaded By		Characterization			
	TP6L72M 450 1000V (Talesun)						HelioScope		Spec Sheet Characterization, PAN			
Component Characterizations	Device						Uploaded By		Characterization			
	CPS SCA25KTL-DO/US-208 (Chint Power Systems)						HelioScope		Default Characterization			

📦 Components		
Component	Name	Count
Inverters	CPS SCA25KTL-DO/US-208 (Chint Power Systems)	1 (25.0 kW)
Home Runs	2/0 AWG (Aluminum)	2 (7.6 ft)
Combiners	2 input Combiner	1
Combiners	3 input Combiner	1
Strings	10 AWG (Copper)	5 (1,871.6 ft)
Module	Talesun, TP6L72M 450 1000V (450W)	78 (35.1 kW)

🔌 Wiring Zones			
Description	Combiner Poles	String Size	Stringing Strategy
Wiring Zone	12	5-19	Along Racking

🏗 Field Segments									
Description	Racking	Orientation	Tilt	Azimuth	Intrarow Spacing	Frame Size	Frames	Modules	Power
Field Segment 1	Fixed Tilt	Landscape (Horizontal)	5°	246.2784°	0.6 ft	1x1	78	78	35.1 kW



Advanced Roofing, Inc. and Advanced Green Technologies are pleased to submit the following information for your consideration regarding the contractor selection on your solar photovoltaic project.

The Advanced Family of Companies was founded in 1983 and built from the ground up on our guiding principle of "Committed to Quality" and by doing what we say we are going to do every time, with no exceptions. Today we are a diversified specialty construction company with annual revenues between \$80 and \$100 million dollars and primarily engaged in the Commercial/Governmental/Industrial Solar, Roofing, and HVAC businesses. Headquartered in Fort Lauderdale, we have offices throughout the State of Florida, Northeast United States, and Toronto Canada that enable us to provide our services nation-wide at a competitive cost structure.

Frederick Douglass Community Center - Site 1

Prepared For

5/16/2023

Frederick Douglass Community Center

786-423-0864

jmosher@keystarconstruction.com



Table of Contents

1 Project Summary	3
2 Project Details	4
2.1 Meter #1	4
2.1.1 PV System Details	4
2.1.2 Rebates and Incentives	5
2.1.3 Utility Rates	6
2.1.4 Current Electric Bill	6
2.1.5 New Electric Bill	7
3 Cash Flow Analysis	8
3.1 Cash Purchase	8



1 Project Summary

Payment Options	Cash Purchase
IRR - Term	12.4%
LCOE PV Generation	\$0.048 /kWh
Net Present Value	\$103,951
Payback Period	8.8 Years
Total Payments	\$104,877
Total Incentives	\$31,463
Net Payments	\$73,414
Electric Bill Savings - Term	\$402,631
Blended Electricity Cost per kWh	\$0.125 /kWh
Energy Cost Escalation Rate	5.0%
Upfront Payment	\$104,877

Combined Solar PV Rating

Power Rating: 35,100 W-DC

Power Rating: 30,574 W-AC-CEC

Cumulative Energy Costs By Payment Option

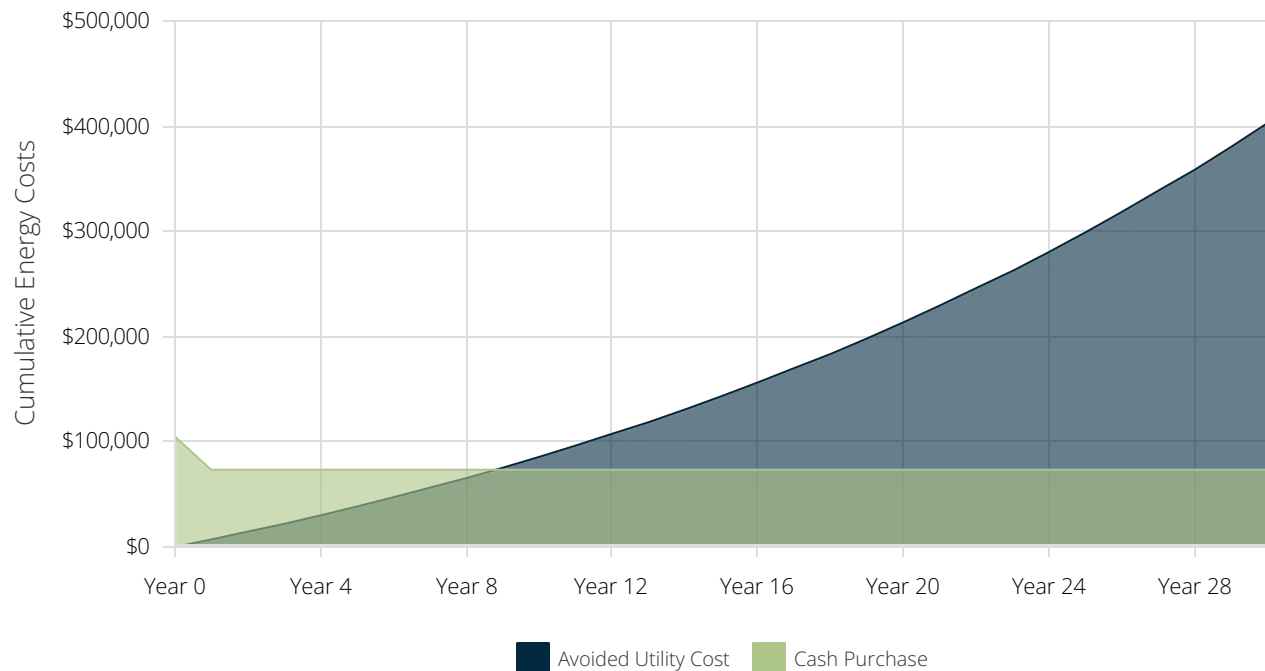

2.1.1 PV System Details

General Information

Facility: Meter #1
 Address: 1300 White St Key West FL 33040

Solar PV System Rating

Power Rating: 35,100 W-DC
 Power Rating: 30,574 W-AC-CEC

Solar PV Equipment Description

Solar Panels: (78) Talesun TP6L72M 450 1000V
 Inverters: (1) Chint Power Systems CPS SCA25KTL-DO/US-208

Energy Consumption Mix

Annual Energy Use: 111,072 kWh

Solar PV Equipment Typical Lifespan

Solar Panels: Greater than 30 Years
 Inverters: 15 Years

Solar PV System Cost and Incentives

Solar PV System Cost	\$104,877
Federal Tax Credit	-\$31,463
Net Solar PV System Cost	\$73,414

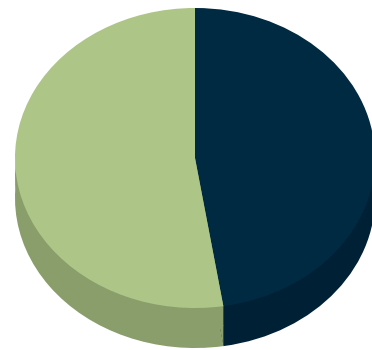

Utility	52,740 kWh (47.48%)
Solar PV	58,332 kWh (52.52%)

Monthly Energy Use vs Solar Generation

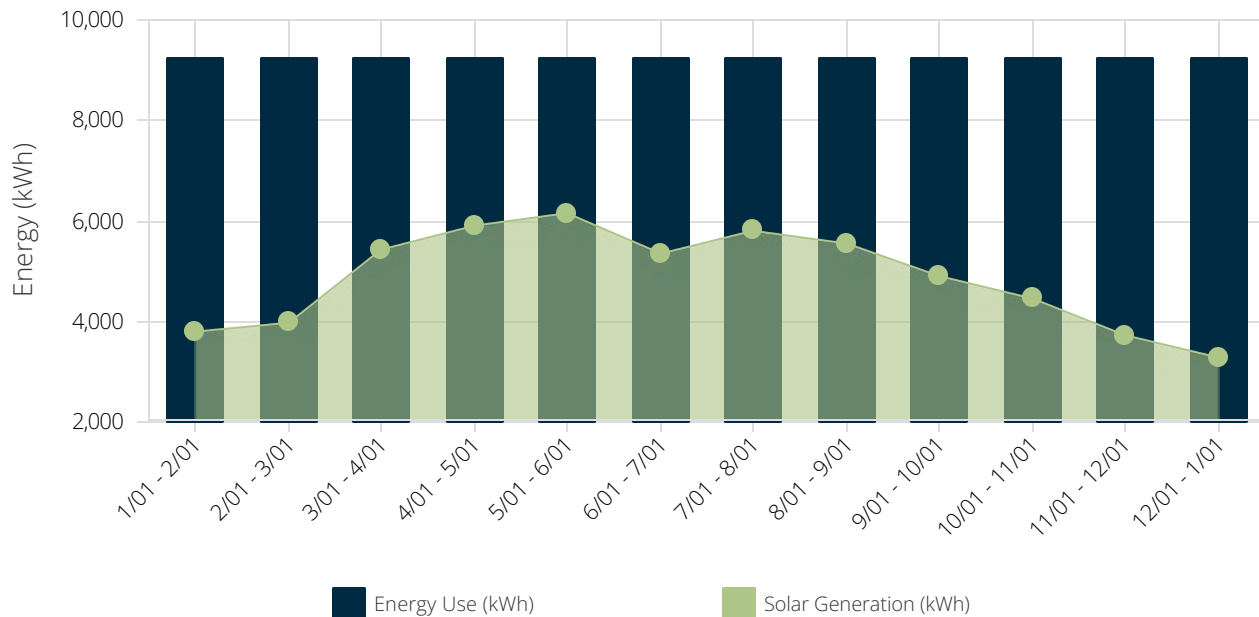

2.1.2 Rebates and Incentives

This section summarizes all incentives available for this project. The actual rebate and incentive amounts for this project are shown in each example.

Business Energy Investment Tax Credit (ITC) - 30%

Businesses that install solar photovoltaic (PV) systems are eligible to receive an (ITC) investment tax credit, which can be used to directly offset federal tax liability on a dollar-for-dollar basis. If the tax credit exceeds your tax liability you can roll the credit into future tax periods for 20 years.

Total Incentive Value: \$31,463



2.1.3 Utility Rates

The table below shows the rates associate with your current utility rate schedule (SC). Your estimated electric bills after solar are shown on the following page.

Customer Charges				Energy Charges			
Season	Charge Type	Rate Type	SC	Season	Charge Type	Rate Type	SC
S1	Flat Rate	per billing period	\$30.00	S1	Flat Rate	Import	\$0.1214

2.1.4 Current Electric Bill

The table below shows your annual electricity costs based on the most current utility rates and your previous 12 months of electrical usage.

Rate Schedule: KEYS - SC

Time Periods	Energy Use (kWh)	Charges		
		Other	Energy	Total
Bill Ranges & Seasons	Total			
1/1/2023 - 2/1/2023 S1	9,256	\$30	\$1,124	\$1,154
2/1/2023 - 3/1/2023 S1	9,256	\$30	\$1,124	\$1,154
3/1/2023 - 4/1/2023 S1	9,256	\$30	\$1,124	\$1,154
4/1/2023 - 5/1/2023 S1	9,256	\$30	\$1,124	\$1,154
5/1/2022 - 6/1/2022 S1	9,256	\$30	\$1,124	\$1,154
6/1/2022 - 7/1/2022 S1	9,256	\$30	\$1,124	\$1,154
7/1/2022 - 8/1/2022 S1	9,256	\$30	\$1,124	\$1,154
8/1/2022 - 9/1/2022 S1	9,256	\$30	\$1,124	\$1,154
9/1/2022 - 10/1/2022 S1	9,256	\$30	\$1,124	\$1,154
10/1/2022 - 11/1/2022 S1	9,256	\$30	\$1,124	\$1,154
11/1/2022 - 12/1/2022 S1	9,256	\$30	\$1,124	\$1,154
12/1/2022 - 1/1/2023 S1	9,256	\$30	\$1,124	\$1,154
Total	111,072	\$360	\$13,484	\$13,844



2.1.5 New Electric Bill

Rate Schedule: KEYS - SC

Time Periods Bill Ranges & Seasons	Energy Use (kWh)	Charges		
	Total	Other	Energy	Total
1/1/2023 - 2/1/2023 S1	5,460	\$30	\$663	\$693
2/1/2023 - 3/1/2023 S1	5,281	\$30	\$641	\$671
3/1/2023 - 4/1/2023 S1	3,827	\$30	\$465	\$495
4/1/2023 - 5/1/2023 S1	3,348	\$30	\$406	\$436
5/1/2022 - 6/1/2022 S1	3,101	\$30	\$376	\$406
6/1/2022 - 7/1/2022 S1	3,905	\$30	\$474	\$504
7/1/2022 - 8/1/2022 S1	3,452	\$30	\$419	\$449
8/1/2022 - 9/1/2022 S1	3,706	\$30	\$450	\$480
9/1/2022 - 10/1/2022 S1	4,351	\$30	\$528	\$558
10/1/2022 - 11/1/2022 S1	4,803	\$30	\$583	\$613
11/1/2022 - 12/1/2022 S1	5,530	\$30	\$671	\$701
12/1/2022 - 1/1/2023 S1	5,976	\$30	\$726	\$756
Total	52,740	\$360	\$6,403	\$6,763

Annual Electricity Savings: \$7,082



3.1 Cash Purchase

Assumptions and Key Financial Metrics

IRR - 10 Year	2.5%	IRR - 20 Year	10.6%	IRR - Term	12.4%
Net Present Value	\$103,951	Payback Period	8.8 Years	ROI	313.9%
PV Degradation Rate	0.80%	Discount Rate	5.0%	Energy Cost Escalation Rate	5.0%
Federal Income Tax Rate	37.5%	State Income Tax Rate	0.0%	Total Project Costs	\$104,877

Years	Project Costs	Electric Bill Savings	Federal Tax Effect	Total Cash Flow	Cumulative Cash Flow
Upfront	-\$104,877	-	-	-\$104,877	-\$104,877
1	-	\$7,082	\$31,463	\$38,545	-\$66,332
2	-	\$7,376	-	\$7,376	-\$58,956
3	-	\$7,683	-	\$7,683	-\$51,273
4	-	\$8,001	-	\$8,001	-\$43,272
5	-	\$8,332	-	\$8,332	-\$34,940
6	-	\$8,677	-	\$8,677	-\$26,263
7	-	\$9,035	-	\$9,035	-\$17,228
8	-	\$9,407	-	\$9,407	-\$7,822
9	-	\$9,793	-	\$9,793	\$1,971
10	-	\$10,195	-	\$10,195	\$12,166
11	-	\$10,612	-	\$10,612	\$22,779
12	-	\$11,046	-	\$11,046	\$33,825
13	-	\$11,497	-	\$11,497	\$45,322
14	-	\$11,965	-	\$11,965	\$57,287
15	-	\$12,451	-	\$12,451	\$69,738
16	-	\$12,956	-	\$12,956	\$82,693
17	-	\$13,480	-	\$13,480	\$96,173
18	-	\$14,024	-	\$14,024	\$110,197
19	-	\$14,589	-	\$14,589	\$124,786
20	-	\$15,175	-	\$15,175	\$139,961
21	-	\$15,783	-	\$15,783	\$155,744
22	-	\$16,415	-	\$16,415	\$172,159
23	-	\$17,070	-	\$17,070	\$189,229
24	-	\$17,749	-	\$17,749	\$206,978
25	-	\$18,454	-	\$18,454	\$225,432
26	-	\$19,185	-	\$19,185	\$244,617
27	-	\$19,943	-	\$19,943	\$264,559
28	-	\$20,728	-	\$20,728	\$285,288
29	-	\$21,543	-	\$21,543	\$306,830
30	-	\$22,387	-	\$22,387	\$329,217
Totals:	-\$104,877	\$402,631	\$31,463	\$329,217	-



PM PROPOSAL

Advanced Green Technologies (AGT) is pleased to submit the following proposal for your consideration of the above-referenced premises as follows. We agree to provide all labor, material, tools, equipment and proper insurance with an excess liability of twelve (12) million dollars.



To:

Jeremy Mosher
Keystar Construction
5450 MacDonald Avenue, Suite 3
Key West, Florida 33040
(786) 423-0864

Job Name:

Frederick Douglass Community Center – Array 2

Address:

1300 White Street
Key West, Florida 33040

Date:

May 16, 2023

Reference:

Preventive Maintenance Proposal – 40.5 kW

DESCRIPTION OF ISSUE

We are pleased to submit the following two-year maintenance proposal (once a year visits) for your consideration on the above referenced location as follows:

SCOPE OF WORK**Inverter Maintenance/Module Inspections:**

- Check Irradiance and Module Temperature
- Check Operating Voltage (AC and DC Voltage) and Current
- Check Inverter status, Inspect inverter cabinet for damage and proper securement.
- Check Filters and clean as needed.
- Check inverter fans for dirt/dust build-up, clean and verify fans are operating properly.
- Measure torque of all electrical connections, re-torque as needed.
- Inspect all conduits for proper connections to supports, couplings and fittings.
- Inspect all visible wire connections to ensure all are properly secured.
- Inspect signs and labels and add or replace as needed.
- Inspect all racking and attachment systems for loose or missing parts. Repair or replace as needed.
- Visually inspect all PV Modules for physical damage and document conditions.
- Confirm no water leakage to any component parts.
- Remove and dispose of any debris covering the modules that may cause shading.
- *A complete documented report will be provided to the client digitally.

EXCLUSIONS

Excludes Lift, if needed.

This is a maintenance proposal only and does not cover labor or parts associated with potential repairs not covered under warranty. Work is based only on Scope of Work listed above, any other issues or problems will be identified, and the responsible party notified.

AGT will make necessary repairs as required after advising the Client of recommended repairs, providing a proposal, and executing scope of work once proposal is approved.

AGT Project Proposal

WARRANTY

Established warranty as stated in original contract agreement.

QUOTATION

Inverter Maintenance/Module Inspections:

FOR THE SUM OF:\$960.00
(Nine Hundred Sixty Dollars)

QUOTATION

Communications and Annual Reporting:

FOR THE SUM OF:\$1,200.00
(One Thousand Two Hundred Dollars)

ANNUAL MAINTENANCE SCHEDULE	
	COSTS
Annual Maintenance: Year 1 - 3	\$2,160.00 (per year)
Annual Maintenance: Year 4 - 6	TBD
Annual Maintenance: Year 7 - 9	TBD
Hourly T&M Rate for Non-O&M Work (2-Man Team)	\$200.00
Travel charges are billed portal to portal at the hourly rate	

All material is guaranteed to be as specified. All work to be completed in a workmanlike manner according to standard practices. Any alteration or deviation from above specifications involving extra costs will be executed only upon written order and will become an extra charge over and above the estimate. All agreements contingent upon strikes, accidents, or delays beyond our control. Owner to carry fire, tornado, and other necessary insurance.

This quote is based on preliminary electrical design, if however final electrical design differs in installed wattage due to site or module size availability, the difference will be calculated at a per watt price.

All material is guaranteed to be as specified. All work to be completed in a workmanlike manner according to standard practices. Any alteration or deviation from above specifications involving extra costs will be executed only upon written order and will become an extra charge over and above the estimate. All agreements contingent upon strikes, accidents, or delays beyond our control. Owner to carry fire, tornado, and other necessary insurance.

Authorized Signature: Tom Griffith

Tom Griffith, Sales Executive

NOTE: This proposal may be withdrawn by us if not accepted within Thirty (30) days.
Owner is responsible for asbestos testing and related cost to remove.

Acceptance of Proposal

The undersigned as (check one) Owner Authorized agent of Owner hereby accepts and agrees to the prices, specifications and conditions indicated above and on the reverse side of this contract.

Accepted: Signature:

Date: Signature:

*Terms & Conditions on last page(s) apply.

State License: CV-C56792

Array B. Low Roof Olivia

Design 1 - Array 2 Frederick Douglass, 111Olivia Street Key West FL 33040

Report	
Project Name	Frederick Douglass
Project Address	111Olivia Street Key West FL 33040
Prepared By	clinton sockman clints@agt.com
	

System Metrics	
Design	Design 1 - Array 2
Module DC Nameplate	40.5 kW
Inverter AC Nameplate	50.0 kW Load Ratio: 0.81
Annual Production	68.61 MWh
Performance Ratio	81.8%
kWh/kWp	1,694.2
Weather Dataset	TMY, 10km Grid (24.55,-81.85), NREL (prospector)
Simulator Version	bea0c32975-f7c166ba04-e5790ed422-e085315a86

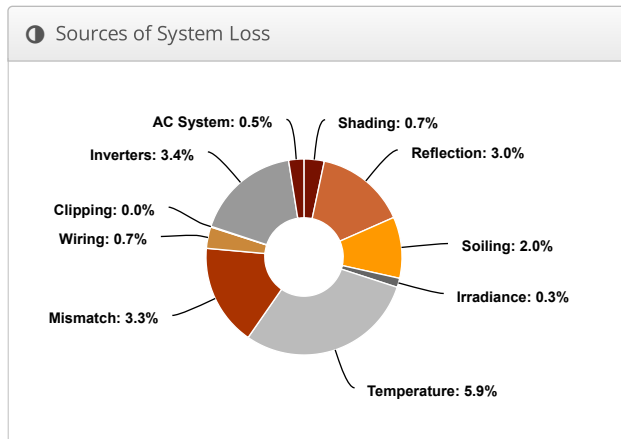
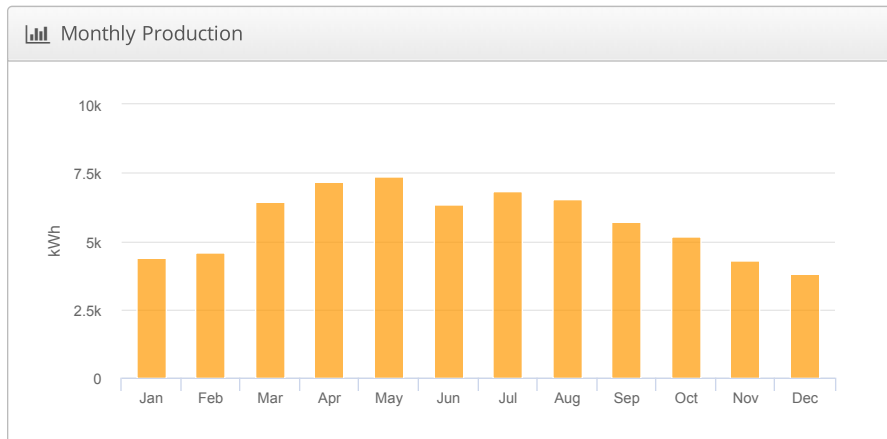
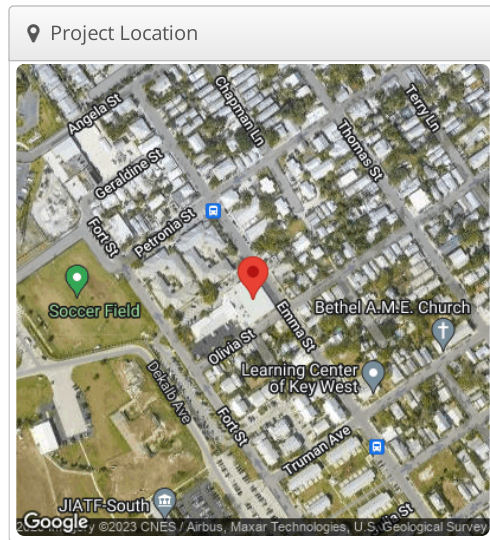

⚡ Annual Production			
	Description	Output	% Delta
Irradiance (kWh/m ²)	Annual Global Horizontal Irradiance	2,047.1	
	POA Irradiance	2,071.1	1.2%
	Shaded Irradiance	2,057.4	-0.7%
	Irradiance after Reflection	1,996.1	-3.0%
	Irradiance after Soiling	1,956.2	-2.0%
	Total Collector Irradiance	1,956.2	0.0%
Energy (kWh)	Nameplate	79,284.2	
	Output at Irradiance Levels	79,044.8	-0.3%
	Output at Cell Temperature Derate	74,406.7	-5.9%
	Output After Mismatch	71,938.7	-3.3%
	Optimal DC Output	71,434.2	-0.7%
	Constrained DC Output	71,418.1	0.0%
	Inverter Output	68,958.6	-3.5%
	Energy to Grid	68,613.8	-0.5%
Temperature Metrics			
	Avg. Operating Ambient Temp		25.5 °C
	Avg. Operating Cell Temp		35.3 °C
Simulation Metrics			
	Operating Hours		4660
	Solved Hours		4660

☁ Condition Set												
Description	Condition Set 1											
Weather Dataset	TMY, 10km Grid (24.55,-81.85), NREL (prospector)											
Solar Angle Location	Meteo Lat/Lng											
Transposition Model	Perez Model											
Temperature Model	Sandia Model											
Temperature Model Parameters	Rack Type	a	b	Temperature Delta								
	Fixed Tilt	-3.56	-0.075	3°C								
	Flush Mount	-2.81	-0.0455	0°C								
	East-West	-3.56	-0.075	3°C								
	Carport	-3.56	-0.075	3°C								
Soiling (%)	J	F	M	A	M	J	J	A	S	O	N	D
	2	2	2	2	2	2	2	2	2	2	2	2
Irradiation Variance	5%											
Cell Temperature Spread	4° C											
Module Binning Range	-2.5% to 2.5%											
AC System Derate	0.50%											
Module Characterizations	Module						Uploaded By		Characterization			
	TP6L72M 450 1000V (Talesun)						HelioScope		Spec Sheet Characterization, PAN			
Component Characterizations	Device						Uploaded By		Characterization			
	CPS SCA25KTL-DO/US-208 (Chint Power Systems)						HelioScope		Default Characterization			

📦 Components		
Component	Name	Count
Inverters	CPS SCA25KTL-DO/US-208 (Chint Power Systems)	2 (50.0 kW)
Home Runs	2/0 AWG (Aluminum)	2 (4.2 ft)
Combiners	3 input Combiner	2
Strings	10 AWG (Copper)	6 (2,386.4 ft)
Module	Talesun, TP6L72M 450 1000V (450W)	90 (40.5 kW)

🔌 Wiring Zones			
Description	Combiner Poles	String Size	Stringing Strategy
Wiring Zone 2	12	5-19	Along Racking

🏠 Field Segments									
Description	Racking	Orientation	Tilt	Azimuth	Intrarow Spacing	Frame Size	Frames	Modules	Power
Field Segment 2	Fixed Tilt	Landscape (Horizontal)	5°	246.2784°	0.6 ft	1x1	90	90	40.5 kW

Detailed Layout

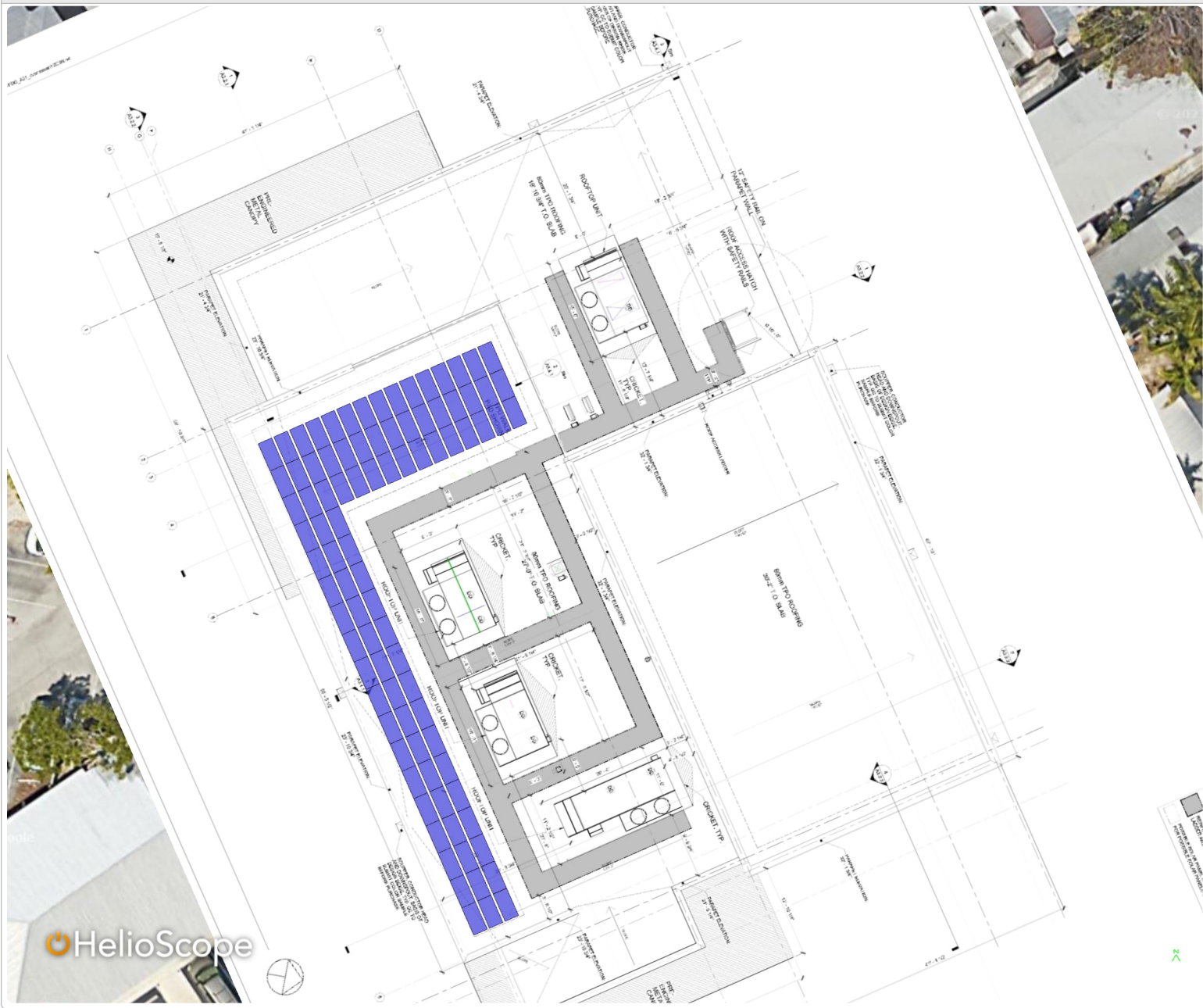



Advanced Roofing, Inc. and Advanced Green Technologies are pleased to submit the following information for your consideration regarding the contractor selection on your solar photovoltaic project.

The Advanced Family of Companies was founded in 1983 and built from the ground up on our guiding principle of "Committed to Quality" and by doing what we say we are going to do every time, with no exceptions. Today we are a diversified specialty construction company with annual revenues between \$80 and \$100 million dollars and primarily engaged in the Commercial/Governmental/Industrial Solar, Roofing, and HVAC businesses. Headquartered in Fort Lauderdale, we have offices throughout the State of Florida, Northeast United States, and Toronto Canada that enable us to provide our services nation-wide at a competitive cost structure.

Frederick Douglass Community Center - Site 2

Prepared For

5/16/2023

Frederick Douglass Community Center
786-423-0864
jmosher@keystarconstruction.com



Table of Contents

1 Project Summary	3
2 Project Details	4
2.1 Meter #1	4
2.1.1 PV System Details	4
2.1.2 Rebates and Incentives	5
2.1.3 Utility Rates	6
2.1.4 Current Electric Bill	6
2.1.5 New Electric Bill	7
3 Cash Flow Analysis	8
3.1 Cash Purchase	8



1 Project Summary

Payment Options	Cash Purchase
IRR - Term	11.0%
LCOE PV Generation	\$0.055 /kWh
Net Present Value	\$92,812
Payback Period	9.9 Years
Total Payments	\$120,472
Total Incentives	\$36,142
Net Payments	\$84,330
Electric Bill Savings - Term	\$402,631
Blended Electricity Cost per kWh	\$0.125 /kWh
Energy Cost Escalation Rate	5.0%
Upfront Payment	\$120,472

Combined Solar PV Rating

Power Rating: 35,100 W-DC

Power Rating: 30,574 W-AC-CEC

Cumulative Energy Costs By Payment Option

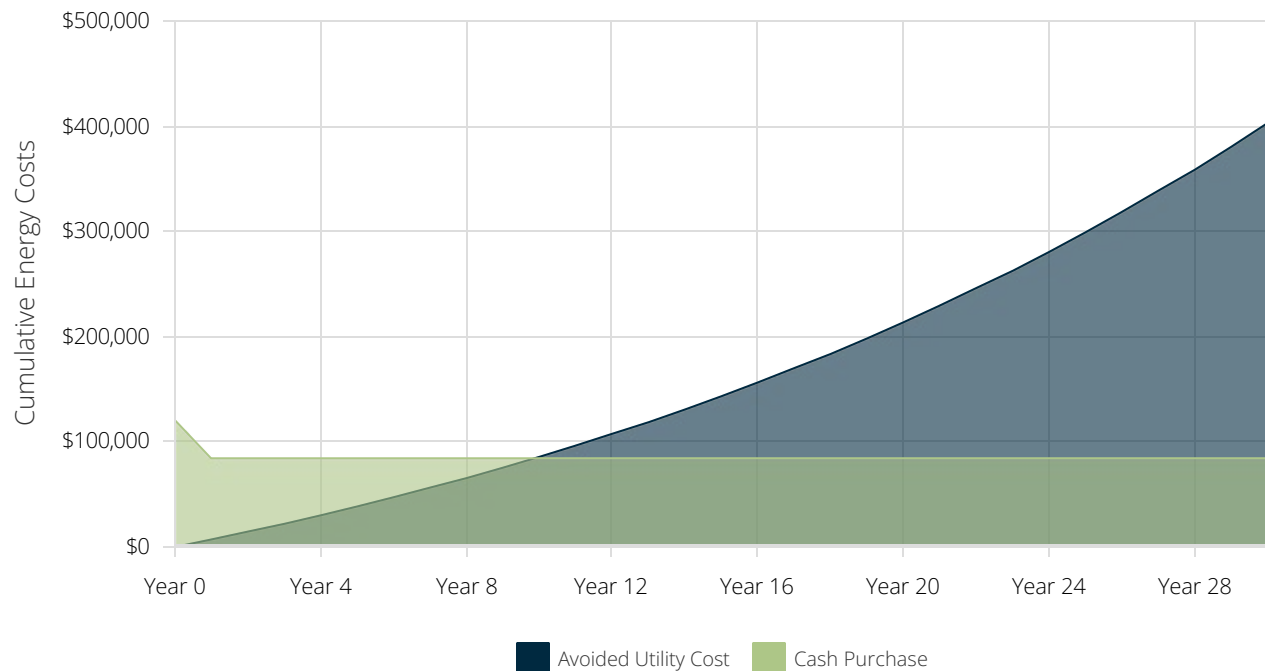

2.1.1 PV System Details

General Information

Facility: Meter #1
 Address: 1300 White St Key West FL 33040

Solar PV System Rating

Power Rating: 35,100 W-DC
 Power Rating: 30,574 W-AC-CEC

Solar PV Equipment Description

Solar Panels: (78) Talesun TP6L72M 450 1000V
 Inverters: (1) Chint Power Systems CPS SCA25KTL-DO/US-208

Energy Consumption Mix

Annual Energy Use: 111,072 kWh

Solar PV Equipment Typical Lifespan

Solar Panels: Greater than 30 Years
 Inverters: 15 Years

Solar PV System Cost and Incentives

Solar PV System Cost	\$120,472
Federal Tax Credit	-\$36,142
Net Solar PV System Cost	\$84,330

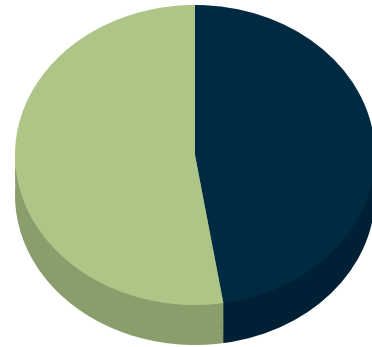

Utility	52,740 kWh (47.48%)
Solar PV	58,332 kWh (52.52%)

Monthly Energy Use vs Solar Generation

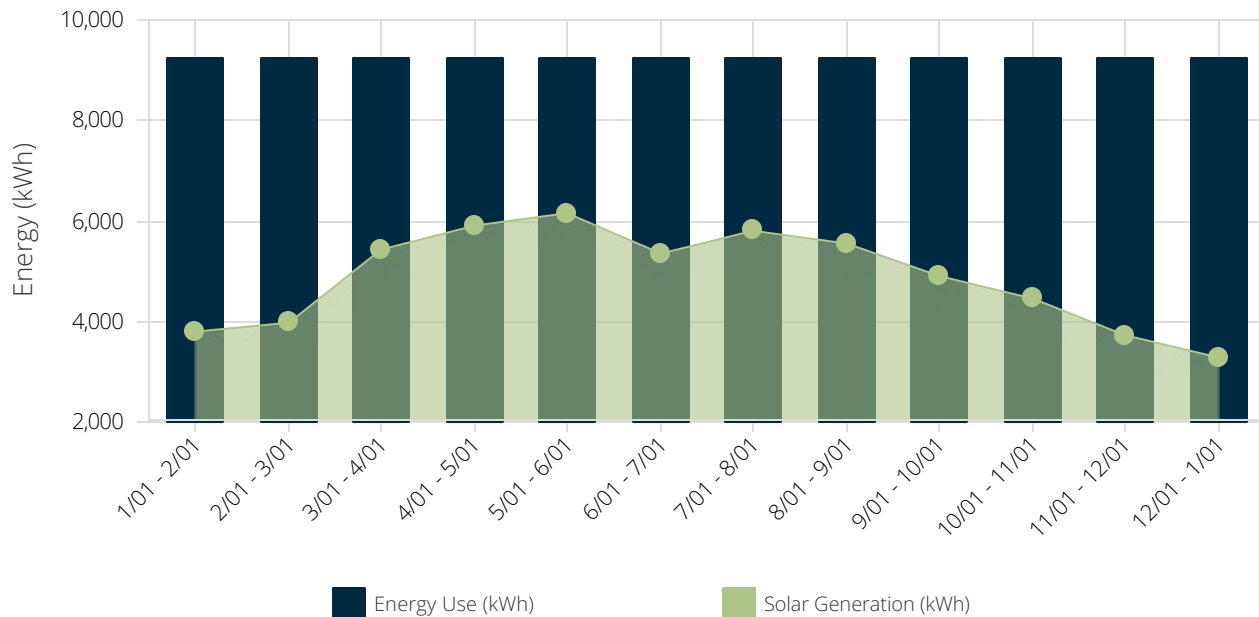

2.1.2 Rebates and Incentives

This section summarizes all incentives available for this project. The actual rebate and incentive amounts for this project are shown in each example.

Business Energy Investment Tax Credit (ITC) - 30%

Businesses that install solar photovoltaic (PV) systems are eligible to receive an (ITC) investment tax credit, which can be used to directly offset federal tax liability on a dollar-for-dollar basis. If the tax credit exceeds your tax liability you can roll the credit into future tax periods for 20 years.

Total Incentive Value: \$36,142



2.1.3 Utility Rates

The table below shows the rates associate with your current utility rate schedule (SC). Your estimated electric bills after solar are shown on the following page.

Customer Charges				Energy Charges			
Season	Charge Type	Rate Type	SC	Season	Charge Type	Rate Type	SC
S1	Flat Rate	per billing period	\$30.00	S1	Flat Rate	Import	\$0.1214

2.1.4 Current Electric Bill

The table below shows your annual electricity costs based on the most current utility rates and your previous 12 months of electrical usage.

Rate Schedule: KEYS - SC

Time Periods	Energy Use (kWh)	Charges		
		Other	Energy	Total
1/1/2023 - 2/1/2023 S1	9,256	\$30	\$1,124	\$1,154
2/1/2023 - 3/1/2023 S1	9,256	\$30	\$1,124	\$1,154
3/1/2023 - 4/1/2023 S1	9,256	\$30	\$1,124	\$1,154
4/1/2023 - 5/1/2023 S1	9,256	\$30	\$1,124	\$1,154
5/1/2022 - 6/1/2022 S1	9,256	\$30	\$1,124	\$1,154
6/1/2022 - 7/1/2022 S1	9,256	\$30	\$1,124	\$1,154
7/1/2022 - 8/1/2022 S1	9,256	\$30	\$1,124	\$1,154
8/1/2022 - 9/1/2022 S1	9,256	\$30	\$1,124	\$1,154
9/1/2022 - 10/1/2022 S1	9,256	\$30	\$1,124	\$1,154
10/1/2022 - 11/1/2022 S1	9,256	\$30	\$1,124	\$1,154
11/1/2022 - 12/1/2022 S1	9,256	\$30	\$1,124	\$1,154
12/1/2022 - 1/1/2023 S1	9,256	\$30	\$1,124	\$1,154
Total	111,072	\$360	\$13,484	\$13,844



2.1.5 New Electric Bill

Rate Schedule: KEYS - SC

Time Periods Bill Ranges & Seasons	Energy Use (kWh)	Charges		
	Total	Other	Energy	Total
1/1/2023 - 2/1/2023 S1	5,460	\$30	\$663	\$693
2/1/2023 - 3/1/2023 S1	5,281	\$30	\$641	\$671
3/1/2023 - 4/1/2023 S1	3,827	\$30	\$465	\$495
4/1/2023 - 5/1/2023 S1	3,348	\$30	\$406	\$436
5/1/2022 - 6/1/2022 S1	3,101	\$30	\$376	\$406
6/1/2022 - 7/1/2022 S1	3,905	\$30	\$474	\$504
7/1/2022 - 8/1/2022 S1	3,452	\$30	\$419	\$449
8/1/2022 - 9/1/2022 S1	3,706	\$30	\$450	\$480
9/1/2022 - 10/1/2022 S1	4,351	\$30	\$528	\$558
10/1/2022 - 11/1/2022 S1	4,803	\$30	\$583	\$613
11/1/2022 - 12/1/2022 S1	5,530	\$30	\$671	\$701
12/1/2022 - 1/1/2023 S1	5,976	\$30	\$726	\$756
Total	52,740	\$360	\$6,403	\$6,763

Annual Electricity Savings: \$7,082



3.1 Cash Purchase

Assumptions and Key Financial Metrics

IRR - 10 Year	0.2%	IRR - 20 Year	9.0%	IRR - Term	11.0%
Net Present Value	\$92,812	Payback Period	9.9 Years	ROI	264.2%
PV Degradation Rate	0.80%	Discount Rate	5.0%	Energy Cost Escalation Rate	5.0%
Federal Income Tax Rate	37.5%	State Income Tax Rate	0.0%	Total Project Costs	\$120,472

Years	Project Costs	Electric Bill Savings	Federal Tax Effect	Total Cash Flow	Cumulative Cash Flow
Upfront	-\$120,472	-	-	-\$120,472	-\$120,472
1	-	\$7,082	\$36,142	\$43,223	-\$77,249
2	-	\$7,376	-	\$7,376	-\$69,872
3	-	\$7,683	-	\$7,683	-\$62,190
4	-	\$8,001	-	\$8,001	-\$54,189
5	-	\$8,332	-	\$8,332	-\$45,856
6	-	\$8,677	-	\$8,677	-\$37,180
7	-	\$9,035	-	\$9,035	-\$28,145
8	-	\$9,407	-	\$9,407	-\$18,738
9	-	\$9,793	-	\$9,793	-\$8,945
10	-	\$10,195	-	\$10,195	\$1,250
11	-	\$10,612	-	\$10,612	\$11,862
12	-	\$11,046	-	\$11,046	\$22,909
13	-	\$11,497	-	\$11,497	\$34,405
14	-	\$11,965	-	\$11,965	\$46,370
15	-	\$12,451	-	\$12,451	\$58,821
16	-	\$12,956	-	\$12,956	\$71,777
17	-	\$13,480	-	\$13,480	\$85,256
18	-	\$14,024	-	\$14,024	\$99,280
19	-	\$14,589	-	\$14,589	\$113,869
20	-	\$15,175	-	\$15,175	\$129,044
21	-	\$15,783	-	\$15,783	\$144,827
22	-	\$16,415	-	\$16,415	\$161,242
23	-	\$17,070	-	\$17,070	\$178,312
24	-	\$17,749	-	\$17,749	\$196,061
25	-	\$18,454	-	\$18,454	\$214,515
26	-	\$19,185	-	\$19,185	\$233,700
27	-	\$19,943	-	\$19,943	\$253,643
28	-	\$20,728	-	\$20,728	\$274,371
29	-	\$21,543	-	\$21,543	\$295,914
30	-	\$22,387	-	\$22,387	\$318,300
Totals:	-\$120,472	\$402,631	\$36,142	\$318,300	-



PM PROPOSAL

Advanced Green Technologies (AGT) is pleased to submit the following proposal for your consideration of the above-referenced premises as follows. We agree to provide all labor, material, tools, equipment and proper insurance with an excess liability of twelve (12) million dollars.



To:

Jeremy Mosher
Keystar Construction
5450 MacDonald Avenue, Suite 3
Key West, Florida 33040
(786) 423-0864

Job Name:

Frederick Douglass Community Center – Array 3

Address:

1300 White Street
Key West, Florida 33040

Date:

May 16, 2023

Reference:

Preventive Maintenance Proposal – 76.1 kW

DESCRIPTION OF ISSUE

We are pleased to submit the following two-year maintenance proposal (once a year visits) for your consideration on the above referenced location as follows:

SCOPE OF WORK**Inverter Maintenance/Module Inspections:**

- Check Irradiance and Module Temperature
- Check Operating Voltage (AC and DC Voltage) and Current
- Check Inverter status, Inspect inverter cabinet for damage and proper securement.
- Check Filters and clean as needed.
- Check inverter fans for dirt/dust build-up, clean and verify fans are operating properly.
- Measure torque of all electrical connections, re-torque as needed.
- Inspect all conduits for proper connections to supports, couplings and fittings.
- Inspect all visible wire connections to ensure all are properly secured.
- Inspect signs and labels and add or replace as needed.
- Inspect all racking and attachment systems for loose or missing parts. Repair or replace as needed.
- Visually inspect all PV Modules for physical damage and document conditions.
- Confirm no water leakage to any component parts.
- Remove and dispose of any debris covering the modules that may cause shading.
- *A complete documented report will be provided to the client digitally.

EXCLUSIONS

Excludes Lift, if needed.

This is a maintenance proposal only and does not cover labor or parts associated with potential repairs not covered under warranty. Work is based only on Scope of Work listed above, any other issues or problems will be identified, and the responsible party notified.

AGT will make necessary repairs as required after advising the Client of recommended repairs, providing a proposal, and executing scope of work once proposal is approved.

AGT Project Proposal

WARRANTY

Established warranty as stated in original contract agreement.

QUOTATION

Inverter Maintenance/Module Inspections:

FOR THE SUM OF:\$960.00
(Nine Hundred Sixty Dollars)

QUOTATION

Communications and Annual Reporting:

FOR THE SUM OF:\$1,200.00
(One Thousand Two Hundred Dollars)

ANNUAL MAINTENANCE SCHEDULE	
	COSTS
Annual Maintenance: Year 1 - 3	\$2,160.00 (per year)
Annual Maintenance: Year 4 - 6	TBD
Annual Maintenance: Year 7 - 9	TBD
Hourly T&M Rate for Non-O&M Work (2-Man Team)	\$200.00
Travel charges are billed portal to portal at the hourly rate	

All material is guaranteed to be as specified. All work to be completed in a workmanlike manner according to standard practices. Any alteration or deviation from above specifications involving extra costs will be executed only upon written order and will become an extra charge over and above the estimate. All agreements contingent upon strikes, accidents, or delays beyond our control. Owner to carry fire, tornado, and other necessary insurance.

This quote is based on preliminary electrical design, if however final electrical design differs in installed wattage due to site or module size availability, the difference will be calculated at a per watt price.

All material is guaranteed to be as specified. All work to be completed in a workmanlike manner according to standard practices. Any alteration or deviation from above specifications involving extra costs will be executed only upon written order and will become an extra charge over and above the estimate. All agreements contingent upon strikes, accidents, or delays beyond our control. Owner to carry fire, tornado, and other necessary insurance.

Authorized Signature: Tom Griffith

Tom Griffith, Sales Executive

NOTE: This proposal may be withdrawn by us if not accepted within Thirty (30) days.
Owner is responsible for asbestos testing and related cost to remove.

Acceptance of Proposal

The undersigned as (check one) Owner Authorized agent of Owner hereby accepts and agrees to the prices, specifications and conditions indicated above and on the reverse side of this contract.

Accepted: Signature:

Date: Signature:

*Terms & Conditions on last page(s) apply.

State License: CV-C56792

Array A. Main Hall Roof

Design 1 - Array 3 Frederick Douglass, 111Olivia Street Key West FL 33040

Report	
Project Name	Frederick Douglass
Project Address	111Olivia Street Key West FL 33040
Prepared By	clinton sockman clints@agt.com
	

System Metrics	
Design	Design 1 - Array 3
Module DC Nameplate	76.1 kW
Inverter AC Nameplate	50.0 kW Load Ratio: 1.52
Annual Production	123.6 MWh
Performance Ratio	78.5%
kWh/kWp	1,625.4
Weather Dataset	TMY, 10km Grid (24.55,-81.85), NREL (prospector)
Simulator Version	bea0c32975-f7c166ba04-e5790ed422-e085315a86

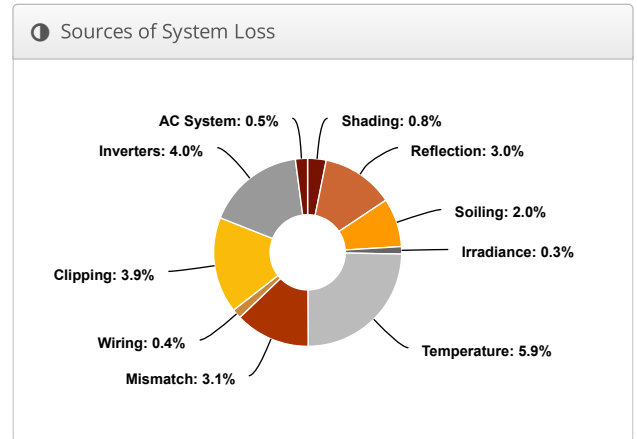
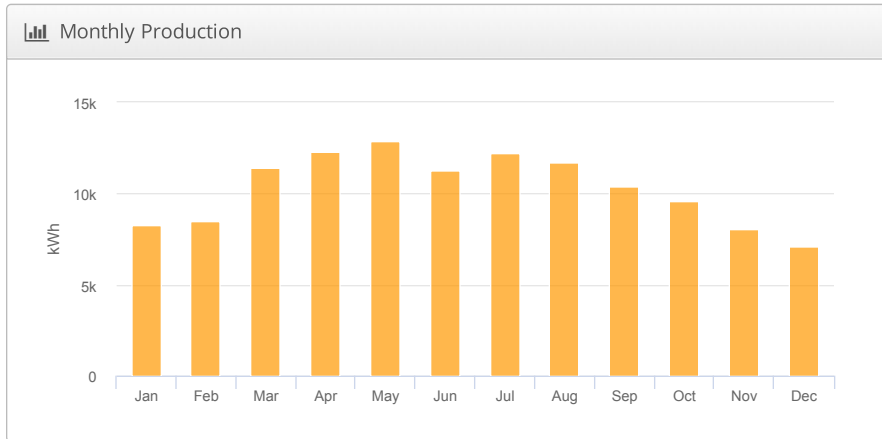
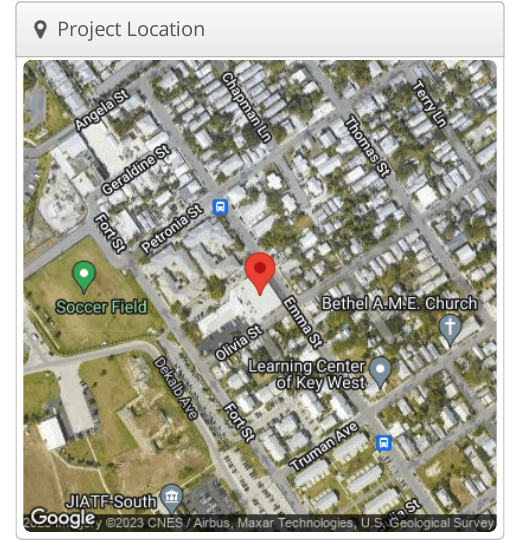

⚡ Annual Production			
	Description	Output	% Delta
Irradiance (kWh/m ²)	Annual Global Horizontal Irradiance	2,047.1	
	POA Irradiance	2,071.1	1.2%
	Shaded Irradiance	2,055.4	-0.8%
	Irradiance after Reflection	1,994.4	-3.0%
	Irradiance after Soiling	1,954.5	-2.0%
	Total Collector Irradiance	1,954.5	0.0%
Energy (kWh)	Nameplate	148,729.9	
	Output at Irradiance Levels	148,280.1	-0.3%
	Output at Cell Temperature Derate	139,578.7	-5.9%
	Output After Mismatch	135,286.2	-3.1%
	Optimal DC Output	134,757.3	-0.4%
	Constrained DC Output	129,450.5	-3.9%
	Inverter Output	124,232.7	-4.0%
	Energy to Grid	123,611.5	-0.5%
Temperature Metrics			
	Avg. Operating Ambient Temp		25.5 °C
	Avg. Operating Cell Temp		35.3 °C
Simulation Metrics			
	Operating Hours		4660
	Solved Hours		4660

☁ Condition Set												
Description	Condition Set 1											
Weather Dataset	TMY, 10km Grid (24.55,-81.85), NREL (prospector)											
Solar Angle Location	Meteo Lat/Lng											
Transposition Model	Perez Model											
Temperature Model	Sandia Model											
Temperature Model Parameters	Rack Type	a	b	Temperature Delta								
	Fixed Tilt	-3.56	-0.075	3°C								
	Flush Mount	-2.81	-0.0455	0°C								
	East-West	-3.56	-0.075	3°C								
	Carport	-3.56	-0.075	3°C								
Soiling (%)	J	F	M	A	M	J	J	A	S	O	N	D
	2	2	2	2	2	2	2	2	2	2	2	2
Irradiation Variance	5%											
Cell Temperature Spread	4° C											
Module Binning Range	-2.5% to 2.5%											
AC System Derate	0.50%											
Module Characterizations	Module						Uploaded By		Characterization			
	TP6L72M 450 1000V (Talesun)						HelioScope		Spec Sheet Characterization, PAN			
Component Characterizations	Device						Uploaded By		Characterization			
	CPS SCA25KTL-DO/US-208 (Chint Power Systems)						HelioScope		Default Characterization			

📦 Components		
Component	Name	Count
Inverters	CPS SCA25KTL-DO/US-208 (Chint Power Systems)	2 (50.0 kW)
Home Runs	2/0 AWG (Aluminum)	3 (163.8 ft)
Combiners	2 input Combiner	1
Combiners	3 input Combiner	1
Combiners	5 input Combiner	1
Strings	10 AWG (Copper)	10 (1,414.7 ft)
Module	Talesun, TP6L72M 450 1000V (450W)	169 (76.1 kW)

🔌 Wiring Zones			
Description	Combiner Poles	String Size	Stringing Strategy
Wiring Zone 3	12	5-19	Along Racking

🏠 Field Segments									
Description	Racking	Orientation	Tilt	Azimuth	Intrarow Spacing	Frame Size	Frames	Modules	Power
Field Segment 3	Fixed Tilt	Landscape (Horizontal)	5°	246.2784°	0.6 ft	1x1	169	169	76.1 kW

Detailed Layout

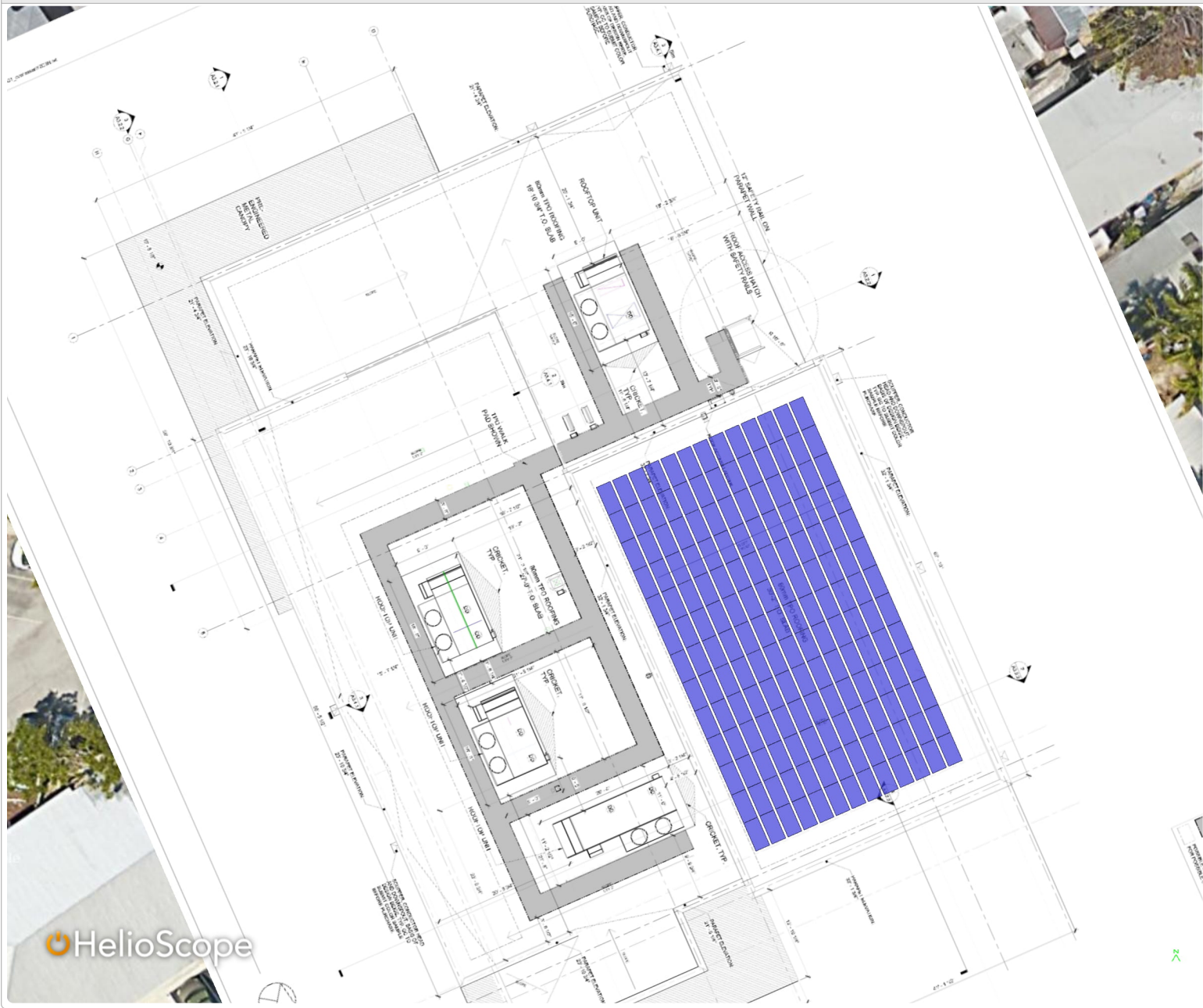



Advanced Roofing, Inc. and Advanced Green Technologies are pleased to submit the following information for your consideration regarding the contractor selection on your solar photovoltaic project.

The Advanced Family of Companies was founded in 1983 and built from the ground up on our guiding principle of "Committed to Quality" and by doing what we say we are going to do every time, with no exceptions. Today we are a diversified specialty construction company with annual revenues between \$80 and \$100 million dollars and primarily engaged in the Commercial/Governmental/Industrial Solar, Roofing, and HVAC businesses. Headquartered in Fort Lauderdale, we have offices throughout the State of Florida, Northeast United States, and Toronto Canada that enable us to provide our services nation-wide at a competitive cost structure.

Frederick Douglass Community Center - Site 3

Prepared For

5/16/2023

Frederick Douglass Community Center

786-423-0864

jmosher@keystarconstruction.com



Table of Contents

1 Project Summary	3
2 Project Details	4
2.1 Meter #1	4
2.1.1 PV System Details	4
2.1.2 Rebates and Incentives	5
2.1.3 Utility Rates	6
2.1.4 Current Electric Bill	6
2.1.5 New Electric Bill	7
3 Cash Flow Analysis	8
3.1 Cash Purchase	8



1 Project Summary

Payment Options	Cash Purchase
IRR - Term	13.1%
LCOE PV Generation	\$0.042 /kWh
Net Present Value	\$216,643
Payback Period	8.3 Years
Total Payments	\$195,679
Total Incentives	\$58,704
Net Payments	\$136,975
Electric Bill Savings - Term	\$802,308
Blended Electricity Cost per kWh	\$0.125 /kWh
Energy Cost Escalation Rate	5.0%
Upfront Payment	\$195,679

Combined Solar PV Rating

Power Rating: 76,050 W-DC

Power Rating: 66,244 W-AC-CEC

Cumulative Energy Costs By Payment Option

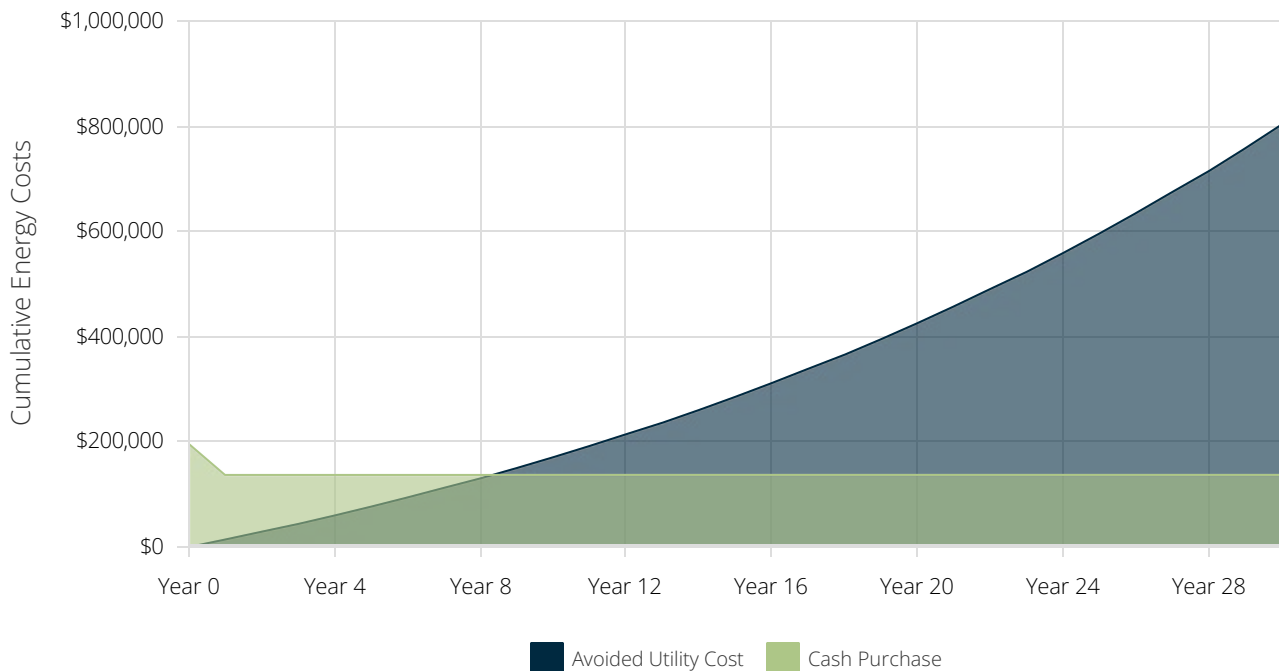

2.1.1 PV System Details

General Information

Facility: Meter #1
 Address: 1300 White St Key West FL 33040

Solar PV System Rating

Power Rating: 76,050 W-DC
 Power Rating: 66,244 W-AC-CEC

Solar PV Equipment Description

Solar Panels: (169) Talesun TP6L72M 450 1000V
 Inverters: (2) Chint Power Systems CPS SCA25KTL-DO/US-208

Energy Consumption Mix

Annual Energy Use: 111,072 kWh

Solar PV Equipment Typical Lifespan

Solar Panels: Greater than 30 Years
 Inverters: 15 Years

Solar PV System Cost and Incentives

Solar PV System Cost	\$195,679
Federal Tax Credit	-\$58,704

Net Solar PV System Cost \$136,975

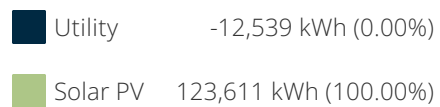
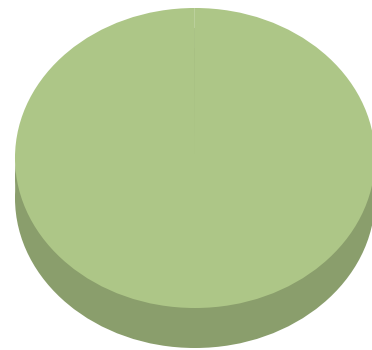

Monthly Energy Use vs Solar Generation

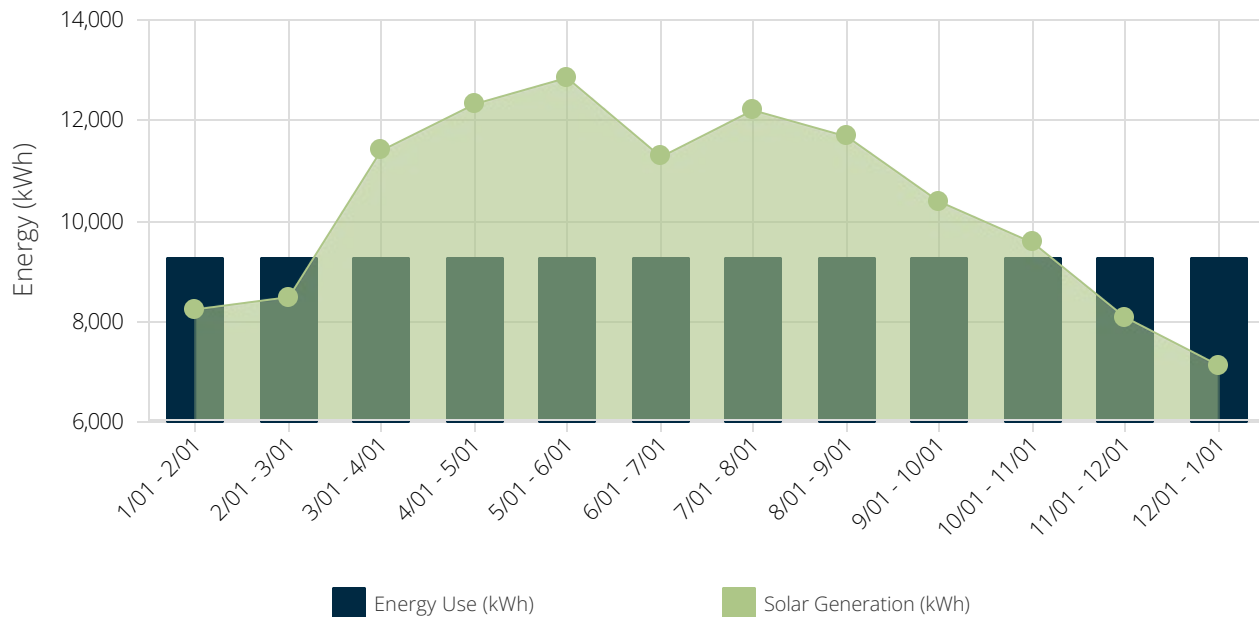

2.1.2 Rebates and Incentives

This section summarizes all incentives available for this project. The actual rebate and incentive amounts for this project are shown in each example.

Business Energy Investment Tax Credit (ITC) - 30%

Businesses that install solar photovoltaic (PV) systems are eligible to receive an (ITC) investment tax credit, which can be used to directly offset federal tax liability on a dollar-for-dollar basis. If the tax credit exceeds your tax liability you can roll the credit into future tax periods for 20 years.

Total Incentive Value: \$58,704



2.1.3 Utility Rates

The table below shows the rates associate with your current utility rate schedule (SC). Your estimated electric bills after solar are shown on the following page.

Customer Charges				Energy Charges			
Season	Charge Type	Rate Type	SC	Season	Charge Type	Rate Type	SC
S1	Flat Rate	per billing period	\$30.00	S1	Flat Rate	Import	\$0.1214

2.1.4 Current Electric Bill

The table below shows your annual electricity costs based on the most current utility rates and your previous 12 months of electrical usage.

Rate Schedule: KEYS - SC

Time Periods	Energy Use (kWh)	Charges		
		Other	Energy	Total
Bill Ranges & Seasons	Total			
1/1/2023 - 2/1/2023 S1	9,256	\$30	\$1,124	\$1,154
2/1/2023 - 3/1/2023 S1	9,256	\$30	\$1,124	\$1,154
3/1/2023 - 4/1/2023 S1	9,256	\$30	\$1,124	\$1,154
4/1/2023 - 5/1/2023 S1	9,256	\$30	\$1,124	\$1,154
5/1/2022 - 6/1/2022 S1	9,256	\$30	\$1,124	\$1,154
6/1/2022 - 7/1/2022 S1	9,256	\$30	\$1,124	\$1,154
7/1/2022 - 8/1/2022 S1	9,256	\$30	\$1,124	\$1,154
8/1/2022 - 9/1/2022 S1	9,256	\$30	\$1,124	\$1,154
9/1/2022 - 10/1/2022 S1	9,256	\$30	\$1,124	\$1,154
10/1/2022 - 11/1/2022 S1	9,256	\$30	\$1,124	\$1,154
11/1/2022 - 12/1/2022 S1	9,256	\$30	\$1,124	\$1,154
12/1/2022 - 1/1/2023 S1	9,256	\$30	\$1,124	\$1,154
Total	111,072	\$360	\$13,484	\$13,844



2.1.5 New Electric Bill

Rate Schedule: KEYS - SC

Time Periods Bill Ranges & Seasons	Energy Use (kWh)	Charges		
	Total	Other	Energy	Total
1/1/2023 - 2/1/2023 S1	1,017	\$30	\$123	\$153
2/1/2023 - 3/1/2023 S1	771	\$30	\$94	\$124
3/1/2023 - 4/1/2023 S1	-2,141	\$30	\$260	\$230
4/1/2023 - 5/1/2023 S1	-3,072	\$30	\$373	\$343
5/1/2022 - 6/1/2022 S1	-3,593	\$30	\$436	\$406
6/1/2022 - 7/1/2022 S1	-2,018	\$30	\$245	\$215
7/1/2022 - 8/1/2022 S1	-2,947	\$30	\$358	\$328
8/1/2022 - 9/1/2022 S1	-2,422	\$30	\$294	\$264
9/1/2022 - 10/1/2022 S1	-1,131	\$30	\$137	\$107
10/1/2022 - 11/1/2022 S1	-308	\$30	\$37	\$7
11/1/2022 - 12/1/2022 S1	1,172	\$30	\$142	\$172
12/1/2022 - 1/1/2023 S1	2,133	\$30	\$259	\$289
Total	-12,539	\$360	\$627	\$267

Annual Electricity Savings: \$14,111



3.1 Cash Purchase

Assumptions and Key Financial Metrics

IRR - 10 Year	3.7%	IRR - 20 Year	11.5%	IRR - Term	13.1%
Net Present Value	\$216,643	Payback Period	8.3 Years	ROI	340.0%
PV Degradation Rate	0.80%	Discount Rate	5.0%	Energy Cost Escalation Rate	5.0%
Federal Income Tax Rate	37.5%	State Income Tax Rate	0.0%	Total Project Costs	\$195,679

Years	Project Costs	Electric Bill Savings	Federal Tax Effect	Total Cash Flow	Cumulative Cash Flow
Upfront	-\$195,679	-	-	-\$195,679	-\$195,679
1	-	\$14,111	\$58,704	\$72,815	-\$122,864
2	-	\$14,698	-	\$14,698	-\$108,165
3	-	\$15,309	-	\$15,309	-\$92,857
4	-	\$15,944	-	\$15,944	-\$76,913
5	-	\$16,604	-	\$16,604	-\$60,309
6	-	\$17,290	-	\$17,290	-\$43,019
7	-	\$18,003	-	\$18,003	-\$25,017
8	-	\$18,744	-	\$18,744	-\$6,272
9	-	\$19,515	-	\$19,515	\$13,242
10	-	\$20,315	-	\$20,315	\$33,558
11	-	\$21,147	-	\$21,147	\$54,705
12	-	\$22,011	-	\$22,011	\$76,716
13	-	\$22,909	-	\$22,909	\$99,625
14	-	\$23,842	-	\$23,842	\$123,467
15	-	\$24,810	-	\$24,810	\$148,278
16	-	\$25,816	-	\$25,816	\$174,094
17	-	\$26,861	-	\$26,861	\$200,955
18	-	\$27,945	-	\$27,945	\$228,899
19	-	\$29,070	-	\$29,070	\$257,970
20	-	\$30,239	-	\$30,239	\$288,209
21	-	\$31,451	-	\$31,451	\$319,660
22	-	\$32,709	-	\$32,709	\$352,369
23	-	\$34,014	-	\$34,014	\$386,383
24	-	\$35,368	-	\$35,368	\$421,752
25	-	\$36,773	-	\$36,773	\$458,524
26	-	\$38,229	-	\$38,229	\$496,753
27	-	\$39,739	-	\$39,739	\$536,492
28	-	\$41,305	-	\$41,305	\$577,797
29	-	\$42,927	-	\$42,927	\$620,724
30	-	\$44,609	-	\$44,609	\$665,333
Totals:	-\$195,679	\$802,308	\$58,704	\$665,333	-



Raising the bar in innovative
DC MLPE solar power systems

RSD-S-PLC

- Meets NEC 2017 (690.12) requirements
- Executes rapid shutdown of system when Transmitter-PLC signal is absent
- Meets SunSpec requirements

RSD-S-PLC Technical Data

Model	RSD-S-PLC
Input Data (DC)	
Input Operating Voltage Range	8-80V
Maximum Cont. Input Current (Imax)	15A
Output Data (DC)	
Output Operating Voltage Range	8-80V
Maximum System Voltage	1000V/1500V
Mechanical Data	
Operating Ambient Temperature Range	-40 °F to +185 °F (-40 °C to + 85 °C)
Dimensions (without cable&connectors)	5" x 1.2" x 0.6"(129 mm x 30 mm x 16 mm)
Cable Length	Input 250mm/Output 1200mm or Customize
Module Connector	MC4 or MC4 Compatible
Enclosure Rating	Type 6P / IP68
Over Temperature Protection	Yes
Features & Compliance	
Communication	PLC
Safety Compliance	NEC 2017 (690.12); UL1741; CSA C22.2 No. 330-17; IEC/EN62109-1; 2PFG2305
EMC Compliance	FCC Part15; ICES-003; IEC/EN61000-6-1/-2/-3/-4

© All Rights Reserved

RSD-S-PLC meets SunSpec requirements, maintaining normal function by continually receiving a heart-beat signal from the APsmart Transmitter. The RSD executes rapid system shutdown when Transmitter signal is absent. Users can manually execute rapid shutdown using Transmitter breaker switch.

RSD-S-PLC Wiring Diagram

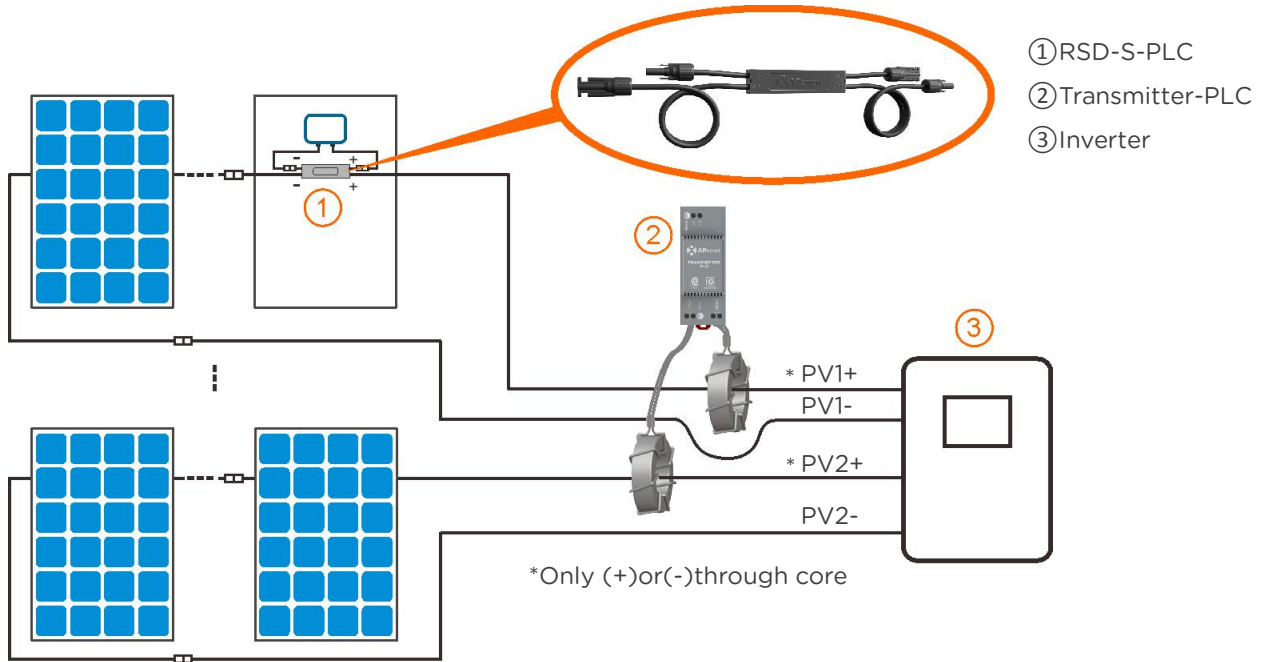

Working Schematic Diagram

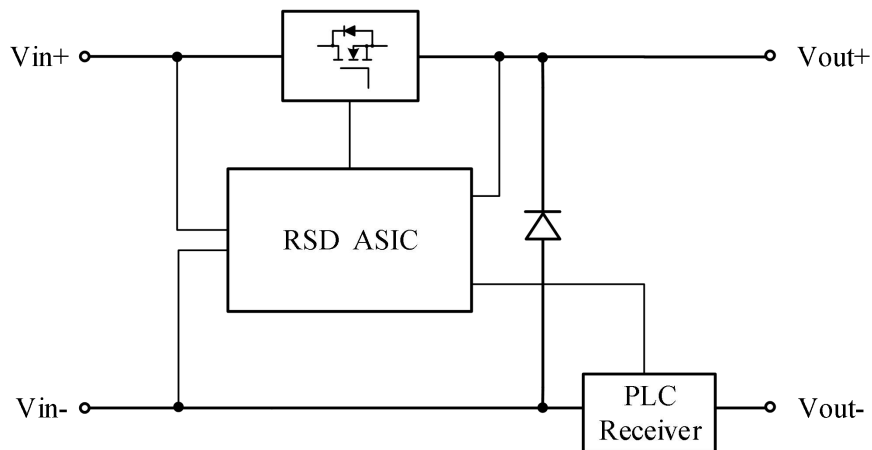

ORDERING INFORMATION

405002	1500V UL/1000V TUV, 1.2m cable, MC4
405001	1000V UL/TUV, 1.2m cable, MC4 compatible
405003	1500V UL/TUV, 1.2m cable, MC4-Evo2

Model Name	CPS SCA25KTL-DO/US-480
DC Input	
Max. PV Power	37.5kW (19kW per MPPT)
Max. DC Input Voltage	1000Vdc
Operating DC Input Voltage Range	200-950Vdc
Start-up DC Input Voltage / Power	330V / 80W
Number of MPP Trackers	2
MPPT Voltage Range @ PF>0.99 ¹	560-850Vdc
Max. PV Short-Circuit Current (Isc x 1.25)	90A (45A/MPPT)
Number of DC Inputs	6 inputs, 3 per MPPT
DC Disconnection Type	Load rated DC switch
DC Surge Protection	Type II MOV, 1240V _C , 15kA I _{TM} (8/20..S)
AC Output	
Rated AC Output Power @ PF=1	25KW
Max. AC Apparent Power	25KVA
Rated Output Voltage	480Vac
Output Voltage Range ²	422 - 528Vac
Grid Connection Type	3Φ / PE / N (Neutral optional)
Max. AC Output Current @480Vac	30.5A
Rated Output Frequency	60Hz
Output Frequency Range ²	57 - 63Hz
Power Factor	>0.99 (±0.8 adjustable)
Current THD @ Rated Load	<3%
Max. OCPD Rating	50A
AC Disconnection Type	Loadbreak rated AC switch
AC Surge Protection	Type II MOV, 1025V _C , 15kA I _{TM} (8/20..S)
System and Performance	
Topology	Transformerless
Max. Efficiency	98.5%
CEC Efficiency	98.0%
Stand-by / Night Consumption	<1W
Environment	
Enclosure Protection Degree	NEMA Type 4X
Cooling Method	Variable speed cooling fans
Operating Temperature Range	-22°F to +140°F / - 30°C to +60°C
Non-Operating Temperature Range ³	No low temp minimum to +158°F / +70°C maximum
Operating Humidity	0 to 100%
Operating Altitude	13,123.4ft / 4000m (derating from 9842.5ft / 3000m)
Audible Noise	<50dBA @ 1m
Display and Communication	
User Interface and Display	LED+Wifi
Inverter Monitoring	SunSpec, Modbus RS485
Site Level Monitoring	CPS Flex Gateway (1 per 32 inverters)
Modbus Data Mapping	CPS
Remote Diagnostics / FW Upgrade Functions	Standard / (with Flex Gateway)
Mechanical	
Dimensions (HxWxD)	Inverter: 15.95 x 15.75 x 7.87in (405 x 400 x 200mm)
	Wirebox: 10.24 x 15.75 x 7.87in (260 x 400 x 200mm)
Weight	Inverter: 48.5lbs/22kg; Wire-box: 13.23lbs/6kg
Mounting / Installation Angle ⁴	15 to 90 degrees from horizontal (vertical or angled)
AC Termination	Screw Clamp (Wire range: #8 - #2 AWG CU/AL)
DC Termination ⁵	Screw Clamp, Wire range: #14 - #8AWG CU
Fused String Inputs (3 per MPPT)	15A fuses provided (Fuse values up to 20A acceptable)
Safety	
Certifications and Standards	UL1741SA-2016, UL1699B, CSA-C22.2 NO.107.1-01, IEEE1547a-2014; FCC PART15
Selectable Grid Standard and SRD	IEEE1547a-2014, CA Rule 21, ISO-NE
Smart-Grid Features	Volt-RideThru, Freq-RideThru, Ramp-Rate, Specified-PF, Volt-VAr, Freq-Watt, Volt-Watt
Warranty	
Standard	10 years
Extended Terms	15 and 20 years

1) See user manual for further information regarding MPPT Voltage Range when operating at non-unity PF.

2) The "Output Voltage Range" and "Output Frequency Range" may differ according to the specific grid standard.

3) See user manual for further requirements regarding non-operating conditions.

4) Shade Cover accessory required for installation angles of 75 degrees or less.

5) Wire-box only includes fuses/fuseholders on the positive polarity, compliant with NEC 2017, 690.9 (C).

ROOFMOUNT | RM5

SOUTH FACING 5 DEGREE TILT



BETTER SOLAR STARTS HERE

RM5 is a ballasted south-facing five-degree tilt mounting system for flat roofs. Fewer components, single tool installation, snap-in hardware, and integrated bonding ensure high speed installation, while features such as 7.5" or 11" row spacing and optional wind deflector, roof attachments, MLPE mount, and wire management provide a complete solution. UNIRAC's unmatched commercial project support makes construction easy, from permitting through installation, and **RM5** is supported by North America's largest distribution network. Plus, enjoy peace of mind with UNIRAC's industry-leading 25-year warranty.

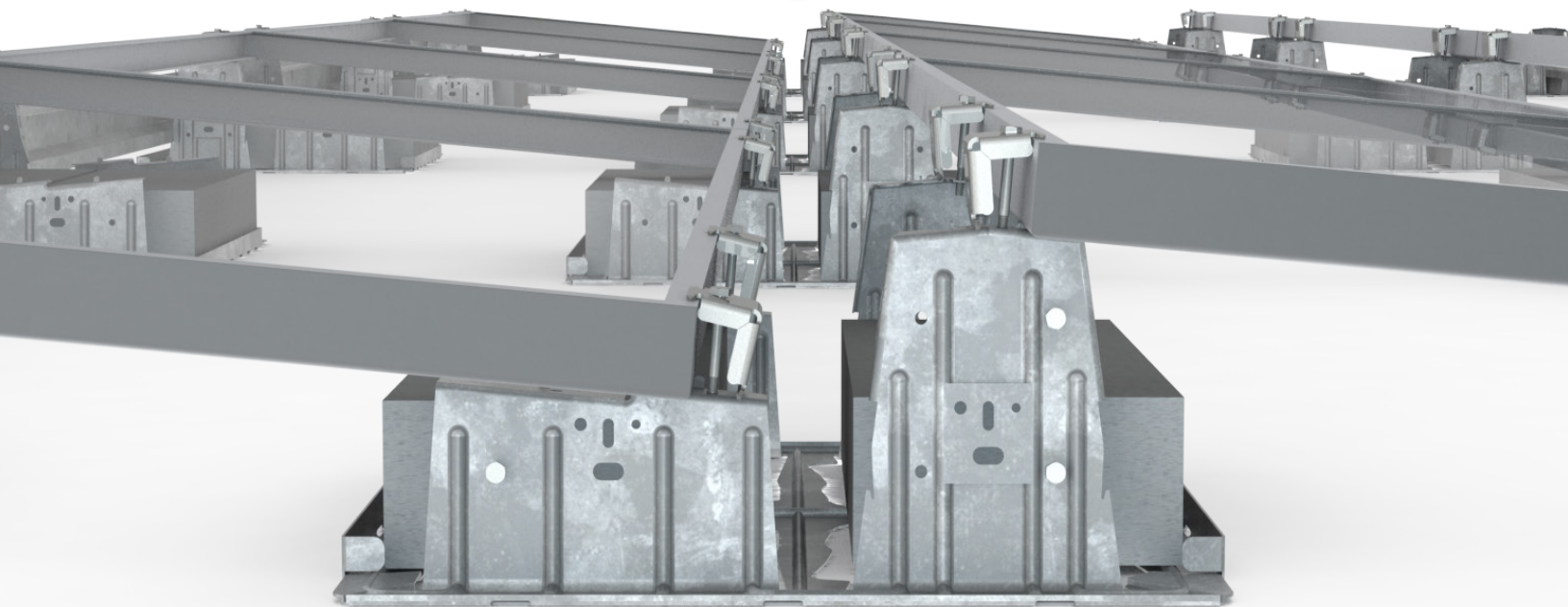

MAXIMIZE PROFITABILITY AT EVERY STEP

FOR QUESTIONS OR CUSTOMER SERVICE VISIT UNIRAC.COM OR CALL (505) 248-2702

ROOFMOUNT | RM5

SOUTH FACING 5 DEGREE TILT



BETTER SOLAR STARTS HERE

OPTIMIZE ARRAY LAYOUT

MAXIMUM LAYOUT FLEXIBILITY WITH TWO ROW SPACING OPTIONS

5 Degree Tilt with 7" / 11" Row Spacing Options

Set, Then Clamp Feature, Provides Better Construction Sequencing for Rapid Installation

Simplified Wire Management, with Two (2) Optional Unirac Clips

Wind Deflector for Ballast Reduction & Fire Mitigation

Optional Roof Attachment Meets a Variety of Project Requirements

MPL Mount with Engage Trunk Cable Wire Management Clip

G235 Steel - Double the Corrosion Protection of other Industry Products

Compact Packaging - Up to 1 MW / Truck

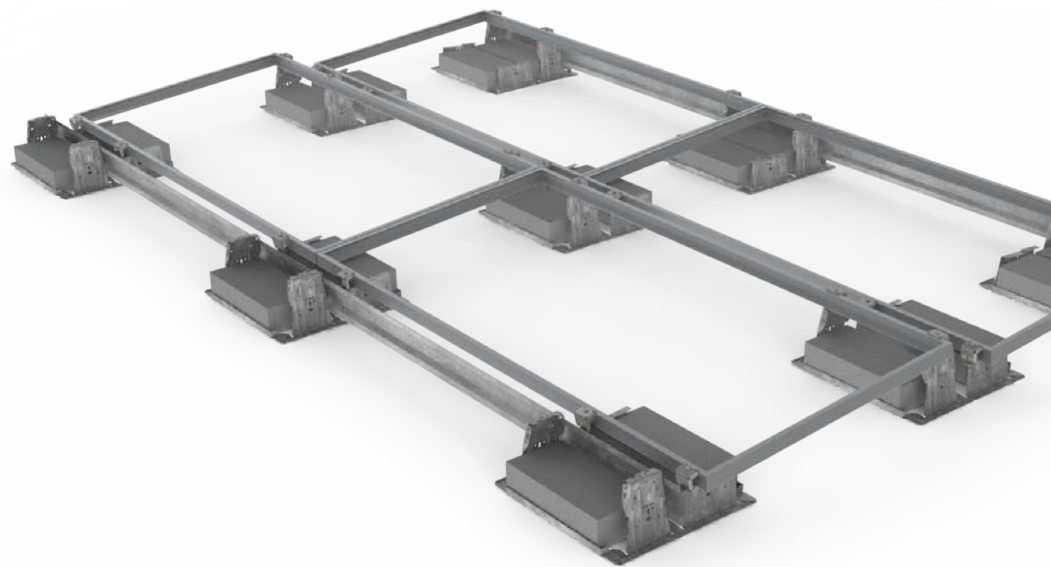
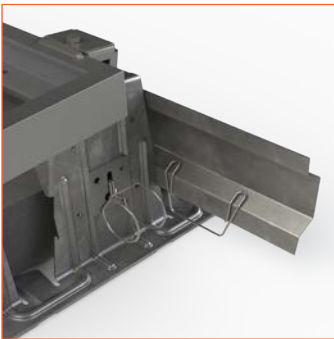

GENERATE LAYOUTS IN MINUTES WITH U-BUILDER ON-LINE DESIGN TOOL

HelioScope Integration • Google & Bing Maps • Ballast Distribution Maps • Site Specific Engineering Reports • Layout Multiple Arrays per Project • CAD Downloads

INDUSTRY LEADING PROJECT SUPPORT

UNIRAC's Team of Technical Experts & Professional Engineers is Your Partner Through Design, Engineering, Permitting and Installation.

GUARANTEED PERMIT APPROVAL

UL2703 Certification Documents • Stamped 3rd Party PE Letters • Construction Drawings • AHJ Outreach Program

FASTEST DELIVERY IN THE INDUSTRY

In Stock & Ready to Ship From North America's Largest Flat Roof Distribution Network.

WORLD CLASS INSTALLATION TRAINING & SUPPORT

Library of QuickTips Installation Videos • Installation Guides • Live Demos • Train the Trainer Program

MAXIMIZE PROFITABILITY AT EVERY STEP

FOR QUESTIONS OR CUSTOMER SERVICE VISIT UNIRAC.COM OR CALL (505) 248-2702

SECURE, WATERTIGHT STRUCTURAL ATTACHMENT SYSTEM

Don't rip it! Grip it!

OMG PowerGrip™ is a roof mount system designed to secure ballasted solar racks and other equipment to roofs covered with single-ply (TPO and PVC) roofing membranes.

OMG
PowerGrip

OMG PowerGrip Plus
3x the Performance

PowerGrip provides a secure connection directly to the roof deck or structural members, thereby taking the wind load off of the membrane or roof cover and onto the structural deck where it belongs. Once secured in place, properly installed PowerGrips can help to eliminate rack movement and remain watertight.

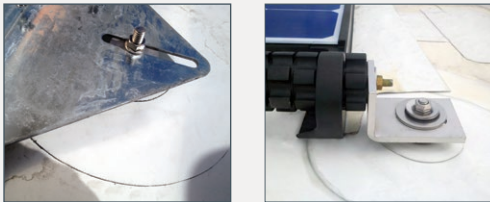

FEATURES & BENEFITS

- Properly installed PowerGrips provide a secure anchor to the roof deck and remain watertight.
- Simple installation process saves time and labor.
- Compatible with most TPO and PVC membranes.
- Helps protect single-ply roof covers from damage due to ballasted rack movement.
- Wide flange is easy to weld in place on thermoplastic roof covers.
- 1½-in. (41 mm) diameter x ½-in. (12 mm) tall mount, provides optimal perch securing brackets or struts.

- Exposed 1-in. (25 mm) tall x ¾-in. (9 mm) diameter bolt and mounting stand are made from corrosion-resistant stainless steel and aluminum alloy for superior long-term performance.
- Available in two sizes: regular PowerGrip and PowerGrip Plus.
- Takes the wind load off of the membrane and onto the structural deck where it belongs.



Based on EcoFasten Solar technology, U.S. Patent No. 8,683,751.

APPLICATION

PowerGrip mounts are designed for uplift and shear retention.

PowerGrip can also be used for many other roof mounted applications, including: pipe supports and hangers, step crossovers, electrical conduit, raceways, satellite dishes, small antennas and HVAC applications, among others.

PowerGrip units are typically installed with one of the following OMG Roofing Product Fasteners based on the specific deck type and roofing application.

- OMG XHD® Roofing Fastener (#15)
- OMG RetroDriller Fastener
- OMG Heavy Duty Roofing Fastener (#14)

Visit OMGRoofing.com for specific fastener details, sizes, specifications and packaging information. Some sizes of XHD Fasteners are also available in 100-packs for PowerGrip installation. Always consult the roofing system manufacturer prior to installation.

PRODUCT DATA SPECIFICATIONS

PERFORMANCE

PRODUCT	TEST	TEST METHOD (in gen. accordance with)	RESULTS
PowerGrip	Tensile Strength	ASTM 1761-06	305 lbf. (1.35 kN) min.
PowerGrip	Shear Strength	ASTM 1761-06	305 lbf. (1.35 kN) min.
PowerGrip Plus	Tensile Strength	TAS 117-95 (A)	2000 lbf. (8.90 kN) min.
PowerGrip Plus	Shear Strength	ASTM E488-96	1075 lbf. (4.78 kN) min.

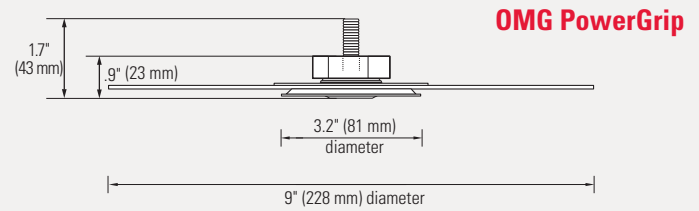

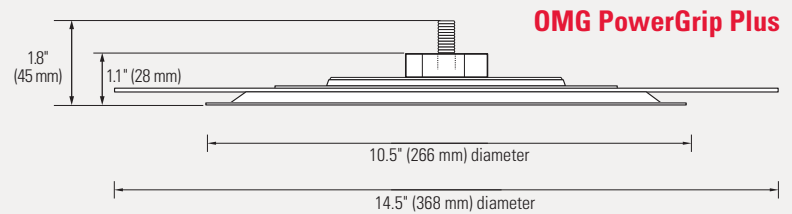

ORDERING INFORMATION

CAT. NO.	DESCRIPTION	PKG QTY	WEIGHT LBS (KG)
Call OMG Customer Service for membrane specific SKU: 800.633.3800	PowerGrip	20	10.5 (4.73) / case
	PowerGrip PLUS	8	16 (7.2) / case

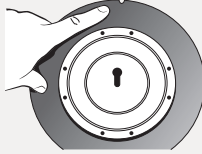
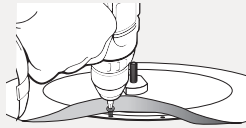

All sizes are nominal.

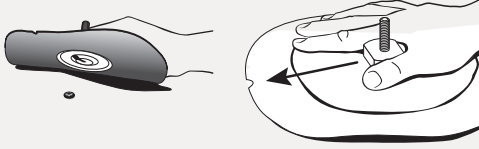
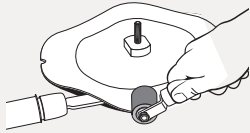
 <p>1. Mark location where PowerGrip is to be installed. Prepare membrane surface at each location following roof system manufacturers' requirements.</p>	 <p>3. Locate the notch on the perimeter of the PowerGrip flange and note how it aligns with the plate on the underside of the PowerGrip.</p>	 <p>4A. *PowerGrip Plus only. Lift the flange and install eight additional fasteners through the PowerGrip Plus plate, hitting the top flutes. Do not fold or crease the membrane during fastener installation.</p>
 <p>2. Install recommended fastener through the roof and deck (min. deck penetration 3/4-in. [20 mm] for steel, 1-in. [25 mm] for wood) using the depth gauge provided, and allowing the fastener head to sit firmly on the gauge card. Do not overdrive.</p>	 <p>4. Slide the assembly over the head of the fastener to position the PowerGrip in the proper location.</p>	 <p>5. Heat Weld the flange of the PowerGrip to the manufacturer's specifications and seal cut edges as required.</p>

For more information, contact your local OMG sales representative, call 800-633-3800 or visit www.OMGRoofing.com.

OMG is a leading U.S. supplier of roofing fasteners, roof insulation adhesives, retrofit roof drains, pipe supports, engineered edge metal systems and rooftop productivity tools. Our products are available nationwide through a network of roofing distributors, and supported by our national network of direct factory sales personnel.

BISTAR

TP6L72M **144 half-cell**

435 - 455W

9BB half-cut mono perc

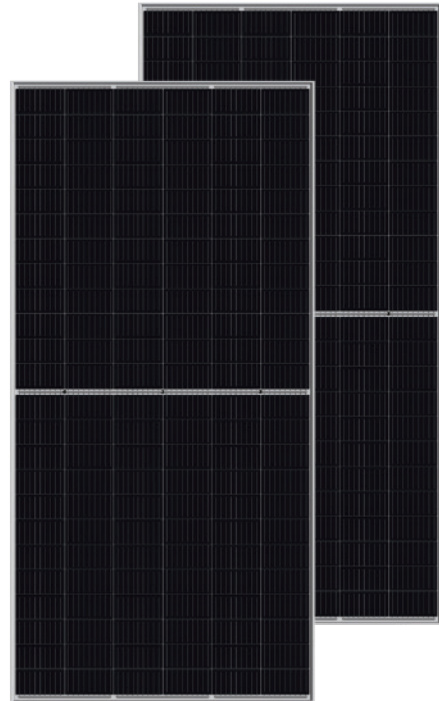

KEY FEATURES



9BB half-cut cell technology

New circuit design, lower internal current, lower Rs loss



Industry leading high yield

Bifacial PERC cell technology,
5%-25% more yield depends on different conditions



Excellent Anti-PID performance

2 times of industry standard Anti-PID test by TUV SUD



Wider application

No water-permeability and high wear-resistance,
can be widely used in high-humid, windy and dusty area



IP68 junction box

High waterproof level

SYSTEM & PRODUCT CERTIFICATES

- IEC 61215 / IEC 61730 / UL 1703
- ISO 9001: 2015 Quality Management System
- ISO 14001: 2015 Environment Management System
- ISO 45001: 2018 Occupational Health and Safety Management Systems



PERFORMANCE WARRANTY

12 years
Quality assurance

25 years
Power output guarantee

■ Talesun standard
■ Industry standard

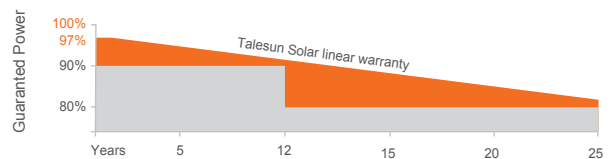

ELECTRICAL PARAMETERS

Performance at STC (Power Tolerance 0 ~ +3%)

Maximum Power (Pmax/W)	435	440	445	450	455
Operating Voltage (Vmpp/W)	40.3	40.5	40.7	40.9	41.1
Operating Current (Impp/A)	10.8	10.87	10.94	11.01	11.08
Open-Circuit Voltage (Voc/V)	49	49.2	49.4	49.6	49.8
Short-Circuit Current (Isc/A)	11.33	11.4	11.47	11.54	11.61
Module Efficiency η (%)	19.8	20.1	20.3	20.5	20.8

Performance at NMOT

Maximum Power (Pmax/W)	324	328	332	335	339
Operating Voltage (Vmpp/W)	37.6	37.8	38.0	38.2	38.4
Operating Current (Impp/A)	8.62	8.67	8.73	8.78	8.84
Open-Circuit Voltage (Voc/V)	45.6	45.8	46.0	46.2	46.4
Short-Circuit Current (Isc/A)	9.15	9.2	9.26	9.32	9.37

STC: Irradiance 1000W/m², Cell Temperature 25°C, Air Mass AM1.5 NMOT: Irradiance at 800W/m², Ambient Temperature 20°C, Air Mass AM1.5, Wind Speed 1m/s

MECHANICAL SPECIFICATION

Cell Type	mono-Crystalline Silicon (9Busbar)
Cell Dimensions	166*166mm (6inches)
Cell Arrangement	144 (6*24)
Weight	25.5kg (56.2lbs)
Module Dimensions	2098*1046*35 (82.60*41.18*1.38inches)
Cable Length	300mm (11.81inches)
Cable Cross Section Size	4mm ² (0.006inches ²)
Front Glass	3.2mm High Transmission, Tempered Glass
No. of Bypass Diodes	3/6
Packing Configuration	30pcs/carton, 660pcs/40hq
Frame	Anodized Aluminium Alloy
Junction Box	IP68

I-V CURVE

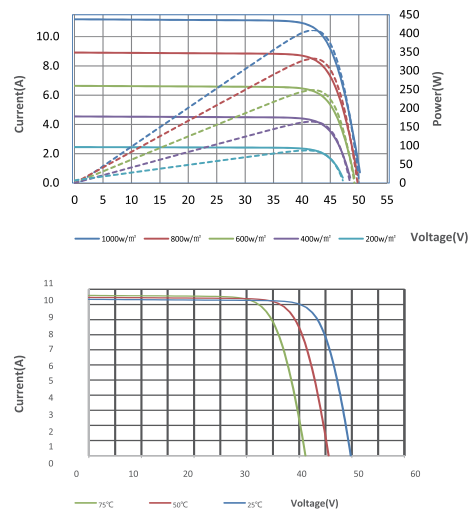

OPERATING CONDITIONS

Maximum System Voltage	1500V/DC
Operating Temperature	-40°C ~ +85°C
Maximum Series Fuse	20A
Static Loading	5400pa
Conductivity at Ground	≤0.1Ω
Safety Class	II
Resistance	≥100MΩ
Connector	MC4 Compatible

TEMPERATURE COEFFICIENT

Temperature Coefficient Pmax	-0.36%/°C
Temperature Coefficient Voc	-0.26%/°C
Temperature Coefficient Isc	+0.043%/°C
NMOT	43±2°C

TECHNICAL DRAWINGS

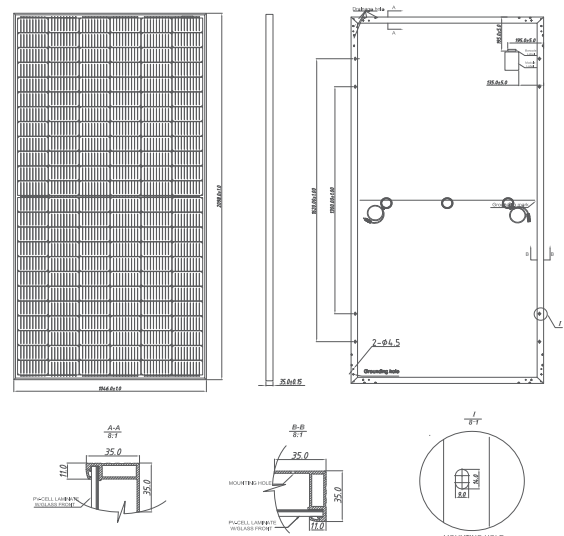

25kW, 1000Vdc String Inverter for North America

The 25kW CPS three phase string inverter is designed for rooftop and carport applications. These units are high performance, advanced and reliable inverters designed specifically for the North American environment and grid. High efficiency at 98.5% peak and 98.0% CEC, wide operating voltages, broad temperature ranges and a NEMA Type 4X enclosure enable this inverter platform to operate at high performance across many applications. The CPS 25kW product ships with a Rapid Shutdown wire-box, fully integrated and separable with touch safe fusing, monitoring, and AC and DC disconnect switches. The integrated PLC transmitter in the Rapid Shutdown wire-box enables PVRSS certified module-level rapid shutdown when used with the Tigo TS4-F/TS4-A-F products. Both models are also PVRSS certified with the -O and -L models. The CPS Flex Gateway enables monitoring, controls and remote product upgrades.



CPS SCA25KTL-DO/US-480

Key Features

- NEC 2017 PVRSS Certified Rapid Shutdown
- NEC 2017 compliant & UL listed Arc-Fault circuit protection
- 15-90° Mounting orientation for low profile roof installs
- Optional Flex Gateway enables remote FW upgrades
- Integrated AC & DC disconnect switches
- 2 MPPT's with 3 inputs each for maximum flexibility
- Copper and Aluminum compatible AC connections
- NEMA Type 4X outdoor rated, tough tested enclosure
- UL1741 SA Certified to CA Rule 21, including SA14 FW and SA15 VW
- Separable wire-box design for fast service
- Standard 10 year warranty with extensions to 20 years
- Generous 1.5 DC/AC Inverter Load Ratio

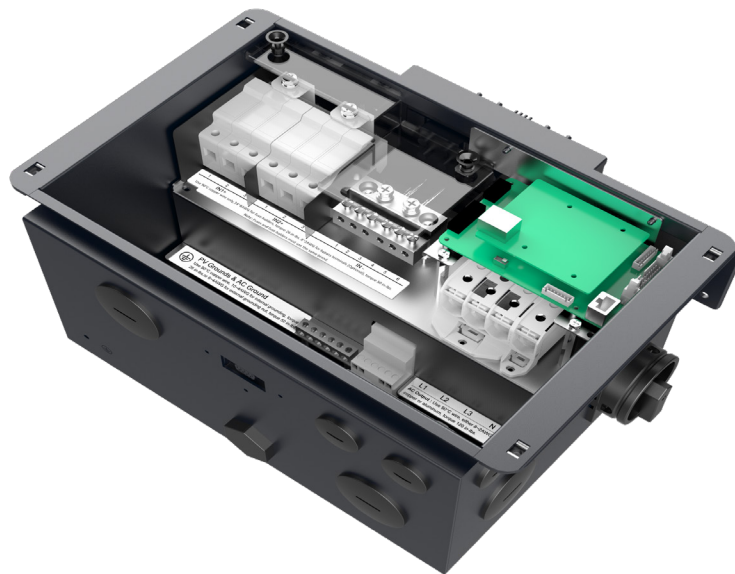

SCA25KTL Wire-box



Dare To Compare

Compiled below is a list of important criteria for any business owner to consider when selecting the right contractor for a solar energy project. Our team has a documented history of exceeding expectations in each category. Before selecting any solar professional, research whether the prospective company satisfies these key areas of concern, or as we like to say "Dare to Compare". Please rank the top three that are most important to you.

___ Longevity in Business

Your solar energy system will last over 20 years, so you want to make sure your solar contractor will still be around. We suggest using a contractor with at least 5 years in the solar industry. *Check out employer's history at your states Division of Corporations website.

___ Financial Stability and Bonding

Contractors go out of business because they do not have proper financials in place. Ask for audited financials, bank references, surety information and/or check online at www.db.com

___ Permit Processing

The #1 reason for delays in projects is incorrect permitting. Choose a contractor that can show you how many permits they process in your city. Ask your contractor how many permits they process on a monthly basis.

___ Protecting Rooftop Warranties

Only contractors with enough experience, Megawatts installed, and strong relationships with roofing materials manufacturer's can ensure that your solar energy system does not void the roof's pre-existing manufacturer's warranty. Check with the manufacturer and make sure your warranty does not get voided.

___ All Under One Roof

Using multiple contractors or subcontractors for different trades, such as engineering and construction will lead to longer timelines and finger pointing. Ask your solar contractor who will be installing your system.

___ Safety

Most solar energy systems are located on the roof, so without safety protocols and management, an accident can stop or delay your project. Ask for your solar contractor's Experience Modification Rate (EMR) ratio.

___ 24/7 Service

It's noon on a Saturday and your system is not producing energy. Who do you call? Require access to your solar contractor 24/7 in case of unexpected emergencies.

___ Reputation, Pride, and Integrity

Pictures can say a thousand words. Choosing a contractor that can back up their claims of quality with documentation, both during the installation and of the final product, can help prevent surprises in quality and professionalism. Ask your solar contractor for pictures and references of completed projects and in-progress photos.

___ Repairs

You have a job to do and it should not be looking after the solar array. Ask for references from customers 5 years past and ask how their solar array is operating to date, and if repairs were needed after the installation.

___ Community Service

Feel good about purchasing your new solar energy system. Ask your potential solar contractors what they do for their community, in addition to their clients.

___ Best Value Proposition

Know what you are getting for your money. The price is competitive but over the life of the system, which bid is your lowest cost/ROI.

MEET OUR TEAM



Robert Kornahrens
Founder, CEO

Robert “Rob” Kornahrens is the founder and CEO of Advanced Green Technologies and Advanced Roofing Inc.

A leader in the construction industry for four decades, Rob has grown his company to over 550 employees with seven offices in Florida; and annual revenues between \$100-\$130+ million.

Education:

Undergraduate studies in Business Administration at the University of Arizona.

Contact:

P: 954-275-8245
E: robk@agt.com



Michael Kornahrens
Executive Vice President

Michael is the Co- Founder and Executive Vice President of Advanced Green Technologies.

Born into the Construction Industry, Michael has successfully completed over 300+ solar installations throughout North America, as well, as earning the top commercial solar contractor ranking in the state of Florida 2011-2022.

Education:

Undergraduate studies in Management at Florida Atlantic University.

Contact:

P: 954-553-8577
E: michaelk@agt.com



Clint Sockman
Vice President

Clint oversees all sales and operations at Advanced Green Technologies.

He has more than a two decades of experience in Field Operations and Construction Management of Commercial, Industrial, and Institutional roofing and solar energy projects. Additionally, Mr. Sockman has successfully lead teams to completion on over 350+ Megawatts of Solar Installations.

Education:

Undergraduate studies in Information Systems with a minor in International Business at the University of Cincinnati. NABCEP Certified.

Contact:

P: 954-232-8772
E: clints@agt.com



Matt Jeffries
Director of Sales &
Strategic Accounts

After spending 17 years with General Electric and servicing material needs for the construction industry, Matt entered the contracting world with Advanced Roofing and Advanced Green Technologies in 2018.

As Director of Sales & Strategic Accounts, Matt holds responsibility for end-to-end client satisfaction. From project discovery through proposal development and project delivery, he serves as a single point of contact for select strategic accounts.

Education:

B.S. in Marketing from University of Indianapolis, possesses Six Sigma Green Belt Certification, and has received several awards from GE including but not limited to: CEO Round Table Advisor 2006-2012; All Star Award 2002-2003; Wired to Inspire Award 2013.

Contact:

P: 954-218-6004
E: mattj@agt.com

"In the solar construction industry, it's not only how the job's performed, it's who the people are, doing it. Their skills, their involvement, and their professional demeanor." - Rob Kornahrens, CEO, Advanced Green Technologies



Darrin Lindsay
Director of
Pre-Construction

Darrin Lindsay is the director of Pre-Construction for Advanced Green Technologies & oversees the design & estimating process for solar projects.

Darrin has over 12 years of experience as an Estimator, Project Engineer and Project Manager in Heavy Civil, Commercial and Solar Construction. Darrin has successfully managed over 70 million dollars in Heavy Civil and Commercial Construction as well as over 25 million dollars in solar projects.

Education:

Bachelor of Science in Building Construction from the University of North Florida.

Contact:

P: 239-340-6900
E: DarrinL@agt.com



Tim Ding
Project Engineer

Tim joined Advanced Green Technologies in 2013, bringing more than 10 years of solar PV system design experience to the team.

He is a NABCEP Certified PV system Inspector, and through his studies at Memorial University of Newfoundland, he possesses a B.S. in Engineering Physics and an M.S. in Organic Solar Cell/Organic LED. As Sr. Process Manager at AGT, Tim designs solar PV packages and Energy Storage Systems (ESS).

Education:

Memorial University of Newfoundland, B.S. in Engineering Physics and an M.S. in Organic Solar Cell/Organic LED

Contact:

P: 954-868-6986
E: timd@agt.com



Greg Bates
Solar Service Manager

With more than 20 years of experience in the electrical construction and facility maintenance industries, Greg joined Advanced Green Technologies in 2020.

He is a Licensed Electrician (FL) and attended electrical trade school in Atlanta, GA through the National Joint Apprenticeship and Training Committee 5-year apprenticeship program. As the Solar Service Manager for AGT, Greg leads a department that strives to maintain, troubleshoot, and upgrade all Solar, EV, and networking systems while providing superior service that results in 100% customer satisfaction.

Education:

A Licensed Electrician (FL) and attended electrical trade school in Atlanta, GA through the National Joint Apprenticeship and Training Committee 5-year apprenticeship program.

Contact:

P: 786-265-7597
E: gregb@agt.com

MEET OUR TEAM



Bryan Cardona
Safety Director

Bryan oversees the Safety Division at Advanced Green Technologies.

He has a decade of experience in the areas of Occupational Safety and Health Management. Bryan's goal for Advanced Green Technologies is to continue being an industry leader in safety while promoting a safety culture and growing OSHA partnerships.

Education

OSHA Authorized Construction Trainer, which allows Bryan to implement the OSHA 10 and 30-hour training courses for our field staff.

Contact:

P: 786-260-5866

E: bryanc@advancedroofing.com



Tom Griffith
Sales Executive

Tom Griffith is a Sales Executive for Advanced Green Technologies.

He is responsible for crafting proposals and financial models that align with customer goals and priorities. Having worked in the renewable energy industry since 2016, he has successfully completed and sold over 90 million dollars of solar projects.

Education

Undergraduate studies in Finance with a minor in Environmental Sciences at Alma College. NABCEP PV Technical Sales Certified.

Contact:

P: 561-519-9847

P: tomg@agt.com



Julia Barton
Key Account Executive

With experience in commercial solar in the European market, Julia joined Advanced Green Technologies in 2021. She has consulted large-scale C&I companies and Fortune 500 companies in reaching their sustainability goals. For AGT, she is responsible for new construction projects and serves as the single point of contact for General Contractors, Architects, and Developers.

Education:

BBA in International Business & Management from the University of Amsterdam

Contact:

P: 954-830-6140

E: JuliaB@agt.com



Robert Bruno
Business Development

Robert (Bob) Bruno has been advising commercial customers on the benefits of Solar for over 16 years. He delivered consulting engagements for large commercial and public sector businesses, supporting their sustainability objectives. Bob represents AGT on the Saint Petersburg Chamber Sustainability Committee. He enjoys educating clients on solar, establishing strong relationships and delivering win-win solutions. At AGT, Bob develops new commercial opportunities for Solar and Roofing projects.

Education

Undergraduate studies in Environmental Science at Kean University, New Jersey

Contact:

P: 908-963-2332

E: robertb@agt.com

SOLAR ENERGY SERVICES

Partner with an award-winning, full-service commercial solar energy contractor with more than 350 MW installed around the world.



Younge Street, CAN

1 Pre-Construction

- Feasibility Study
- Financial Analysis
- Design & Engineering
- Permitting & Application

2 Construction

- Project Management
- Product Procurement
- Installation
- Commissioning

3 Post-Construction

- Preventive Maintenance
- Upgrading Technology
- Data Monitoring
- Emergency Response Team

Market Segments Served

- Developers
- Education
- Government / Municipality
- Independent Power Producers
- Not-for-Profit
- Private/Business
- Utilities

ROOFTOP SOLUTIONS

JM Family Enterprises



JM Family Enterprises

Project Size: 150 kW
Location: Deerfield Beach, Florida
Completion: 2014
Role: Engineering, Procurement & Construction

University of Miami



University of Miami

Project Size: 71 kW
Location: Coral Gables, Florida
Completion: 2015
Role: Engineering, Procurement & Construction

Raymour & Flanigan



Raymour & Flanigan

Project Size: 1.1 MW
Location: Gibbstown, New Jersey
Completion: 2012
Role: Engineering, Procurement & Construction

Toys "R" Us



Toys "R" Us Inc.

Project Size: 5.3 MW
Location: Flanders, New Jersey
Completion: 2011
Role: Engineering, Procurement & Construction

View a complete list of our solar projects at www.agt.com

CARPORT SOLUTIONS

Florida International University

Project Size: 1.4 MW
Location: Miami, Florida
Completion: 2016
Role: Engineering, Procurement & Construction

Lockheed Martin

Project Size: 2.25 MW
Location: Oldsmar, Florida
Completion: 2015
Role: Engineering, Procurement & Construction

Konica Minolta

Project Size: 839 kW
Location: Ramsey, New Jersey
Completion: 2014
Role: Engineering, Procurement & Construction

Resolve Marine

Project Size: 61 kW
Location: Fort Lauderdale, Florida
Completion: 2015
Role: Engineering, Procurement & Construction

View a complete list of our solar projects at www.agt.com



GROUND-MOUNT SOLUTIONS



Sudbury Solar Farm



John U. Lloyd Park Solar Farm



Osceola Solar Facility



Marsh Hill Solar Farm

Sudbury Solar Farm

Project Size: 10 MW
Location: Ontario, Canada
Completion: 2014
Role: Engineering, Procurement & Construction

John U. Lloyd Park Solar Farm

Project Size: 53 kW
Location: Dania Beach, Florida
Completion: 2012
Role: Engineering, Procurement & Construction

Osceola Solar Facility

Project Size: 4.7 MW
Location: Kenansville, Florida
Completion: 2016
Role: Engineering, Procurement & Construction

Marsh Hill Solar Farm

Project Size: 10 MW
Location: Ontario, Canada
Completion: 2015
Role: Engineering, Procurement & Construction

View a complete list of our solar projects at www.agt.com



MAINTENANCE & WARRANTY

Preventative maintenance on your solar array is something that should be taken into careful consideration. At Advanced Green Technologies (AGT), we make sure your solar energy system is in tip-top shape year-round. To ensure your system is functioning properly, it is important to perform daily monitoring, semi-annual inspections and cleaning. These measures of preventative maintenance help to fix problems before further damage incurs, stop problems before they start, and guarantee that your solar energy system has a longer service life.

Don't wait... be proactive

- Some advantages of Advanced Roofing's Preventative / Proactive Maintenance Program are:
- Proactive maintenance that ensures your warranty remains intact
- Restoration options for qualifying roofs as opposed to replacement
- All types of roofs qualify – built-up, modified bitumen, single-ply, metal, and tile

A Warranty is only as strong as the financial strength of the company that issues it

In addition to the **reputation** and **strength** of our company, your warranty is covered by not just our promise, but by our own captive insurance company, ARI Insurance, Inc.

With assets of over **\$2,600,000**, you will have insurance on your warranty to **cover and pay for any warranty repairs** in the unlikely event they are needed.

OUR CLIENTS

At Advanced Green Technologies, your experience matters most!

Advanced Green Technologies has extensive experience working with developers, utilities, businesses and educational entities throughout North America to design, build, and install world-class solar energy solutions.

Learn about the customers we serve below and discover why they choose to partner with us.

OUR CLIENTS

Below are a few of our many satisfied customers.

- Publix Super Markets
- Lockheed Martin
- JP Morgan
- JM Family Enterprises
- City Furniture
- University of Miami
- Siemens Corporation
- Konica Minolta

James M. Rice
CEO
Nautilus Solar

"I am pleased to recommend Advanced Green Technologies as an honest, reliable, and problem-solving solar Engineering Procurement and Construction company.

As of this writing, the Advanced Team has completed a total of eight commercial rooftop solar energy projects totaling of 4.7 MW in Ontario, Canada and the United States."

Kathleen Watson, LEED AP
Facilities Project Manager
JM Family Enterprises

"Advanced Green Technologies understands the high standards that define JM Family and are very efficient in delivering on time and on budget solar energy solutions. As part of the solar projects, AGT was able to overcome several challenges including facilitating utility rebates and interconnections, designing the solar arrays to meet FM Global Insurance 200MPH high-wind speeds, creating custom mounting solutions, all while maintaining our pre-existing roof warranties."

Antoinette Kelly
Business Administrator / Board Secretary
Cresskill Board of Education

"The Cresskill Board of Education strongly recommends the work of Advanced Green Technologies who was hired to design and construct a 513 kilowatt solar array on the roof of our Middle and High School buildings.

The Advanced Team completed the project on time and on budget, with no safety incidents. The installed solar system is operating as planned, and producing clean energy for our schools."

Kyle Bartz
Director of Energy Management
Toys "R" Us Inc.

"First and foremost I would like to personally thank Advanced Green Technologies for what I have declared a flawless installation of 37,414 solar panels which signifies the completion of North America's largest operational solar rooftop installation to date at 5.38MW."



Award Winning Solar Contractor

We are uncompromising in our pursuit of excellence. Perhaps the greatest testament to our commitment to quality and philanthropy is the recognition we have received from our peers and community.

Below are just a few awards we have earned throughout the years, as well as, associations we are committed to supporting.

For a complete list of our awards, associations, and community service projects visit www.agt.com

AWARDS & RECOGNITION



1st Place Sustainability
2014
JM Family Enterprises



1st Place Sustainability
2015
University of Miami



1st Place Sustainability
2016
Lockheed Martin

ASSOCIATIONS & COMMUNITY SERVICE



CONTRACT TERMS & CONDITIONS

The following provisions form part of the contract between the parties hereto. Advanced Roofing, Inc. will be referred to as "Advanced":

GUARANTEE: Unless otherwise provided in the body of this contract, solar photovoltaic jobs are guaranteed by ARI Insurance, Inc. for two years from the date the work is completed, the premium for which is included in the contract amount. The guarantee covers any defect in workmanship or in materials supplied by Advanced under this contract. The guarantee does not cover failures or defects beyond the control of Advanced, including but not limited to those caused by electrical fire, windstorms, hurricanes, tornados, lightning, plant or animal life, such as termites, damage caused by Owner or other parties, or work done by parties not under the control of Advanced. Structural, Mechanical and electrical modifications are not part of Advanced 's responsibility unless included in the scope of work otherwise described herein. Advanced's total liability under this guarantee shall not exceed the total amount paid to Advanced pursuant to this contract. In no event shall Advanced be liable for consequential damages, lost energy production, or lower than expected energy production, and all such claims are expressly waived. Claims made under this guarantee shall be made to ARI Insurance, Inc. c/o Advanced Roofing, Inc. Advanced Roofing is authorized to photograph the property in order to determine the scope of services, marketing, or other purposes associated with the project.

CLAIMS: All claims for nonfulfillment of the contract shall be made in writing within 30 days from completion of the work. Advanced reserves the right to correct any condition for which it is responsible including damage to other property. In the event others repair or attempt to repair any problem with the work done by Advanced, unless authorized by Advanced in writing, all guarantees and warranties associated with this project shall be void and of no other further force and effect. Advanced shall not be liable for any cost of work or repairs to its work done by others unless previously authorized by Advanced in writing.

PAYMENT: Owner has represented to Advanced that it has the funds available to make payment and has further agreed to supply financial records satisfactory to Advanced, prior to commencement of construction. Owner agrees that, if requested to do so by Advanced, Owner shall complete a credit application authorizing Advanced to investigate the credit worthiness, credit history and/or financial responsibility of Owner. If Advanced in its sole discretion is not satisfied with Owner's current or future ability to pay, or Owner fails to complete a credit application, Advanced may terminate this contract without penalty. Final payment is due on the completion of the job and is a condition precedent to any warranty or guarantee obligation of Advanced or ARI Insurance, Inc. Any release, lien waiver or warranty issued pursuant to this project is delivered in escrow subject to payment and may be cancelled for nonpayment. Advanced's right to payment is not contingent upon the acceptance of work done by others and over which Advanced has no control. Interest shall accrue at eighteen percent per annum on all amounts not paid within 30 days of the date payment was due. All payments made via credit card or debit card are subject to a three percent (3%) processing fee.

REBATES: Please be advised that the contract price has been reduced by the amount of any applicable rebates. The contractor shall receive all rebates, in which Owner agrees to execute any documents necessary for the contractor to recover payment for same.

UNFORESEEN CONDITIONS: This proposal is limited to the scope of work described and does not include structural issues which may be discovered during the course of the work. In the event that unforeseen conditions arise that were not apparent upon visual inspection, such additional work shall be performed on a time and material basis over the price stated in this contract. Examples of conditions which will be considered an unforeseen condition giving rise to an increase in the cost of the job would be the discovery of defective or deficient concrete, concealed mechanical, electrical, or plumbing components, additional roofs; changes in the structural deck type/gauge or the attachment of the decking throughout the facility; deck replacement; deck securement/fastening; deck minimum gauge or deck conditions requiring repair beyond proposal allowance, existing structure capacity to support the additional load of the proposed solar array, utility transformer capacity, utility interconnection agreement requirements for site infrastructure upgrades, or any other condition that Advanced should not reasonably have anticipated from visual inspection and included in the price provided for in the contract. It is recommended that a structural engineer inspect the roof deck and building structure.

OWNER RESPONSIBILITIES: Unless otherwise provided for in the body of this contract, Owner is responsible for any of the following conditions: Asbestos testing and removal expenses, if any; wind uplift and moisture testing if required; engineering and attachment or enhancement of the existing/proposed roof deck system and any structural component of the building; the condition of the existing/proposed deck slope, structural integrity of the deck, method of attachment of the deck, buried conduits, and equipment below the deck or any other structural deficiencies which may contribute to preventing solar installation; Waterproofing of the building envelope, including windows, doors, or other areas outside the scope of work performed by Advanced. Owner may be responsible for moving or otherwise protecting signs, lighting antennas, satellite dishes or other property or equipment which interferes with the reroofing of the property and agrees not to hold Advanced liable for damage to same unless Advanced accepted the responsibility therefore. Customer/Owner acknowledges that during the course of the installation process it is possible for small amounts of debris, including but not limited to, insulation or roofing fabric, to fall inside the structure. ARI will use its best efforts to minimize such an occurrence. However, the parties stipulate and agree ARI shall not be liable for any claim, loss, or damage associated with debris falling inside the structure during the roof removal process.

PRE-CONSTRUCTION INSPECTION/LEAKS: Roofs through no fault of Advanced, can leak into the building during the course of the installations process. Advanced shall use best practices to minimize the risk of leaks but owner agrees not to hold it liable for leaks not directly caused as a result of negligent practices. Additionally, interior damage generally pre-exists commencement of the solar project. Owner agrees to provide access to all interior areas and top floor units in order for the parties to document pre-existing damage. The risk is upon Owner, who agrees to indemnify and hold Advanced harmless, against any claim by Owner or any other party seeking to hold Advanced liable for damages where Advanced was not provided access during its pre-construction inspections to the areas in question. Owner also shall have the responsibility to notify its residents of the steps that must be taken to protect their property, which will be contained in the Start-Up letter provided by Advanced. Owner shall also provide the staging area and cooperate to inform and assist in preventing residents or others from entering that area or any area under construction.

EXISTING PROPERTY OR EQUIPMENT: Unless otherwise specified in this contract, Advanced shall not be liable for damage to property or equipment, including signs lighting fixtures, antennas, satellite dishes or other equipment at the property which is reasonably at risk from the work performed by Advanced. Any expenses incurred by Advanced to protect said property shall be paid for by Owner.

Advanced Green Technologies

RISK OF DAMAGE: It can be expected that the work will cause vibration, which could cause damage to the building or its contents. The Owner is in the best position to secure said property or, in the case of others who occupy interior units, to advise them of the need to do so. Advanced does not assume any risk and shall not be held liable for damage to stained, cracked or damaged ceilings or ceiling components, cracked or damaged plaster, molding, insulation, acoustical tile or personal property or fixtures within or about the building(s), cracks in driveways, curbs and sidewalks or soffit repair or replacement. Additionally, Advanced shall not be liable for damage to parked vehicles or property located in or about the staging area assigned for its use, or for any damage or injury for respiratory problems which may result from the odors associated with its work. The Owner shall advise its tenants and employees of these risks and concerns and take such action as it deems reasonable to protect persons, and property of Owner and others from damage or injury.

DELAYS: Advanced shall not be liable in any respect for any delays caused by strikes, labor disputes, material shortages, court injunctions, actions by the Owner or by third parties, Acts of God, unforeseen conditions, or other conditions outside of its control. In the event Advanced must remobilize as a result of any action for which the Owner is responsible, or due to weather or other conditions not the responsibility of Advanced, Advanced shall be entitled to an increase of the contract price attributed thereto. If it is necessary to perform additional work in order to protect the property from adverse weather, or to repair work damaged by adverse weather, Advanced will be entitled to a change order for reimbursement for same.

MATERIAL PRICE CHANGES: Due to extreme volatility in material prices, if, subsequent to the execution of the contract, there is an increase in the price of materials necessary for the completion of the Work, the Contract Price shall be equitably adjusted to reflect the additional cost. The equitable adjustment is applicable to all material price increases including, but not limited to, steel, steel-related products, aluminum, copper, roofing material and solar material and equipment. Advanced will provide written documentation reflecting the increased charges. A fuel surcharge may be added if the price of fuel increases by more than 5% between the time the contract is signed and commencement.

BREACH: In the event Owner terminates or breaches this contract, or if a condition attributable to Owner or Owner's property arises that prevents Advanced from fulfilling the contract, Advanced shall be entitled to be paid that percentage of the contract price as the percentage of work performed; plus, for work not performed, all expenses incurred in preparing to perform same, mobilization expenses and profit which would have been realized had the work been completed. If the contract is canceled as a result of strike, labor dispute or conditions not the fault of or attributable to either party hereto, Advanced shall be entitled to recover from Owner that percentage of the contract price as the percentage of work performed; plus for work not performed, all expenses incurred in preparing to perform same, mobilization expenses or other expenses incurred related to the project but not profit for work not performed.

DISPUTES: The prevailing party in any litigation, arbitration or mediation arising out of or relating to this contract shall be entitled to recover its reasonable attorneys' fees and costs from the non-prevailing party, at both the trial level and on appeal. Broward County, Florida, shall be the sole and exclusive venue for any litigation arising from or relating to this contract. Owner hereby expressly consents to the exclusive personal jurisdiction of the state and federal courts located in Broward County, Florida for any lawsuit filed arising from or related to this contract and waives any argument that any such court lacks jurisdiction or that venue in such forum is not convenient. In the event Owner commences any action arising under this contract in another jurisdiction or venue, Advanced shall, at its sole option, be entitled to have the case transferred to one of the jurisdictions and venues above stated, or if such transfer cannot be accomplished under applicable law, Owner consents to have such case dismissed without prejudice.

NO ORAL PROMISES: There are no promises, representations or understandings outside of this instrument which instrument represents the complete agreement between the parties. No modification of this contract shall be valid unless in writing, signed by the party against whom the change is asserted. Any notification required by this contract shall be made in writing.

LIMITATION OF LIABILITY: Advanced Roofing is not liable for any claim for injury or damages, whether based upon a contractual, statutory or tort theory, which result from: (a) natural disasters including but not limited to lightning, windstorm, hail, hurricane, tornado, wind gale force or greater; (b) misuse, neglect, or unauthorized alterations of the roofing/solar system or as a result of or connected with materials supplied or installed by others; (c) exposure to damaging substances such as oil, solvents etc.; (d) failure of the substrate, surface or materials under the roof; (e) improper drainage; (f) lack of recommended maintenance; (g) damage resulting from water entry from any portion of the building structure which is not a part of the roofing system, (h) any claim related in any way to damage or injuries from mold, spores, fungus, any organic pathogen or exposure to toxic or noxious substances fumes or vapors or (i) failure of any manufacturer warranted products IE modules, inverters, racking, ETC. Warranties are only a pass thru of manufacturer coverage and additional shipping, removal, and installation charges may be incurred. Advanced Roofing shall have no obligation under this Contract until all bills for installation, service, and materials have been paid for in full. The Owner will, at its expense, initiate an ongoing maintenance program to include keeping all modules cleaned, inverter air filters cleaned/replaced, terminations inspected and properly torqued, electrical circuits inspected and thermal photographed, structural components inspected, and roof areas cleaned, roofing sealants replaced. If this solar system is covered under a manufacturer's Warranty, Advanced is not liable for the provisions thereof. The warranty and liability of Advanced Roofing shall only accrue to and be for the benefit of the original Owner named herein, and is NOT assignable or transferable without prior written approval and inspection by Advanced Roofing.

TO THE FULLEST EXTENT PERMITTED BY APPLICABLE LAW, ADVANCED ROOFING, INC. DISCLAIMS ANY IMPLIED WARRANTY, INCLUDING THE WARRANTY OF MERCHANTABILITY AND THE WARRANTY OF FITNESS FOR A PARTICULAR PURPOSE, OR LIMITS SUCH WARRANTY TO THE DURATION AND TO THE EXTENT OF THE EXPRESS WARRANTY REPRESENTED BY THIS WARRANTY.

Advanced Roofing's exclusive responsibility and liability under this warranty has been transferred to ARI Insurance, Inc. and, in the case of a new solar system, to make repairs that may be necessary to repair workmanship related items for the term of Advanced Roofing's warranty period; and in the case of a repair, to repair any additional faults which result from faulty repair work done by Advanced Roofing. (Owner acknowledges that faults may come from more than one possible source and that Advanced Roofing does not guarantee that its repair will stop faults not associated with the area repaired by it.) Advanced Roofing shall not be liable for its own negligence, or under theories of statutory or strict liability or any other theory of liability other than the exclusive liability set forth in this warranty which Owner agrees is its sole remedy notwithstanding the type or category of damages claimed. Under any circumstance, Advanced Roofing will not be liable for any personal injury claims, or claims for consequential damages to the structure (upon which the roofing system is affixed) or its contents, loss of time or profits or any inconvenience or expense incurred by Owner. Any change to the provisions of this section must be in writing and signed by a corporate officer of Advanced Roofing, Inc.

ANY CLAIMS FOR CONSTRUCTION DEFECTS ARE SUBJECT TO THE NOTICE AND CURE PROVISIONS OF CHAPTER 558, FLORIDA STATUTES



CONTACT US



1950 NW 22nd Street
Fort Lauderdale, Florida 33311



+ 800-638-6869



www.agt.com

LIC# CVC56792

SUBCONTRACTORS

The Bidder further proposes that the following subcontracting firms or businesses will be awarded subcontracts for the following portions of the work in the event that the Bidder is awarded the Contract:

Charley Toppino & Sons

Name

129 Toppino Industrial Dr, Key West, FL, 33040

Street City State Zip

Name A Plus Roofing

5686 Maloney Ave, Key West, FL, 33040

Street City State Zip

Name

Street City State Zip

Name

Street City State Zip

Name

Street City State Zip

SURETY

Merchants Bonding Company _____ whose address is
6700 Westown Pkwy _____, West Des Moines _____, IA _____, 50266-7754
Street _____ City _____ State _____ Zip _____

BIDDER

The name of the Bidder submitting this Proposal is

Keystar, Inc _____ doing business at
506 Fleming St _____, Key West _____, FL _____, 33040
Street _____ City _____ State _____ Zip _____

which is the address to which all communications concerned with this Proposal and with the Contract shall be sent.

The names of the principal officers of the corporation submitting this Proposal, or of the partnership, or of all persons interested in this Proposal as principals are as follows:

Name	Title
Charles Spottswood	President
_____	_____
_____	_____
_____	_____
_____	_____

If Sole Proprietor or Partnership

IN WITNESS hereto the undersigned has set his/ her (its) hand this _____ day of _____ 2023.

Signature of Bidder

Title _____

If Corporation

IN WITNESS WHEREOF the undersigned corporation has caused this instrument to be executed and its seal affixed by its duly authorized officers this 25 day of May 2023.

(SEAL)

Keystar, Inc
Name of Corporation

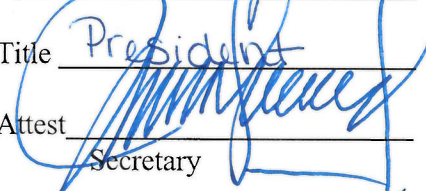
By 
Title President
Attest 
Secretary

EXPERIENCE OF BIDDER

The Bidder states that he/ she is an experienced CONTRACTOR and has completed similar projects within the last 5 years.

(List similar projects, with types, names of OWNERS, construction costs, ENGINEERS, and references with phone numbers. Use additional sheets if necessary.)

Joe Pinder Administration Building-Demo/Rebuild

Owner: Florida Keys Aqueduct Authority

Cost: \$15M, Engineer: Pope-Scarborough Architects

Greg Veliz: 305-296-2454

Garden View Apartments -New Build Apartments

Owner: Housing Authority of the City of Key West Florida

Cost: \$21M, Engineer: William P. Horn Architect, P.A.

Randy Sterling: 305-296-5621

Signature FBO Hanger-Renovation-Offices/Hanger

Owner: Signature Flight Support

Cost: \$1.1M, Engineer: Schenkel Shultz Architecture

David Mason: 407-408-6241

MCSO Administration Building-Exterior EFIS Renovation and Repairs

Owner: Monroe County Board of County Commissioners

Cost: \$315k, Engineer: amec foster wheeler

Mike Rice: 305-797-0362

ANTI-KICKBACK AFFIDAVIT

STATE OF Florida)

: SS

COUNTY OF Monroe)

I, the undersigned hereby duly sworn, depose and say that no portion of the sum herein bid will be paid to any employees of the City of Key West as a commission, kickback, reward or gift, directly or indirectly by me or any member of my firm or by an officer of the corporation.

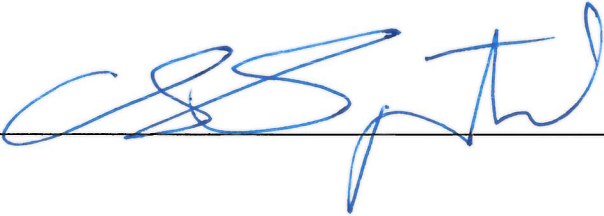
By: 

Sworn and subscribed before me this 29 day of May 2023.

NOTARY PUBLIC, State of Florida at Large



My Commission Expires: Feb 14, 2026

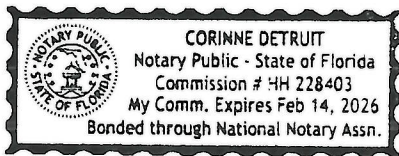

* * * * *

**SWORN STATEMENT UNDER SECTION 287.133(3)(A)
FLORIDA STATUTES, ON PUBLIC ENTITY CRIMES**

THIS FORM MUST BE SIGNED IN THE PRESENCE OF A NOTARY PUBLIC OR OTHER OFFICER AUTHORIZED TO ADMINISTER OATHS.

1. This sworn statement is submitted with Bid or Proposal for ITB #23-005
Frederick Douglass Community Center (FDCC)

2. This sworn statement is submitted by Keystar, Inc.
(name of entity submitting sworn statement)

whose business address is 506 Fleming St., Key West, FL 33040

and (if applicable) its Federal Employer Identification Number (FEIN) is 65-0866227

(If the entity has no FEIN, include the Social Security Number of the individual signing this sworn statement _____)

3. My name is Charles Spottswood
(please print name of individual signing)

and my relationship to the entity named above is Co-President

4. I understand that a "public entity crime" as defined in Paragraph 287.133(1)(g), Florida Statutes, means a violation of any state or federal law by a person with respect to and directly related to the transaction of business with any public entity or with an agency or political subdivision of any other state or with the United States, including but not limited to, any bid or contract for goods or services to be provided to any public or an agency or political subdivision of any other state or of the United States and involving antitrust, fraud, theft, bribery, collusion, racketeering, conspiracy, material misrepresentation.

5. I understand that "convicted" or "conviction" as defined in Paragraph 287.133(1)(b), Florida Statutes, means a finding of guilt or a conviction of a public entity crime, with or without an adjudication of guilt, in any federal or state trial court of record relating to charges brought by indictment information after July 1, 1989, as a result of a jury verdict, nonjury trial, or entry of a plea of guilty or nolo contendere.

6. I understand that an "affiliate" as defined in Paragraph 287.133(1)(a), Florida Statutes, means

- a. A predecessor or successor of a person convicted of a public entity crime; or
- b. An entity under the control of any natural person who is active in the management of the entity and who has been convicted of a public entity crime. The term "affiliate" includes those officers, directors, executives, partners, shareholders, employees, members, and agents who are active in the management of an affiliate. The ownership by one person of shares constituting controlling interest in another person, or a pooling of equipment or income among persons when not for fair market value under an arm's length agreement, shall be a prima facie case that one person controls another person. A person who knowingly enters into a joint venture with a person who has been convicted of a public entity crime in Florida during the preceding 36 months shall be considered an affiliate.

7. I understand that a "person" as defined in Paragraph 287.133(1)(8), Florida Statutes, means any natural person or entity organized under the laws of any state or of the United States with the legal power to enter into a binding contract and which bids or applies to bid on contracts for the provision of goods or services let by a public entity, or which otherwise transacts or applies to transact business with public entity. The term "person" includes those officers, directors, executives, partners, shareholders, employees, members, and agents who are active in management of an entity.
8. Based on information and belief, the statement which I have marked below is true in relation to the entity submitting this sworn statement. (Please indicate which statement applies).

Neither the entity submitting this sworn statement, nor any officers, directors, executives, partners, shareholders, employees, members, or agents who are active in management of the entity, nor any affiliate of the entity have been charged with and convicted of a public entity crime subsequent to July 1, 1989, AND (Please indicate which additional statement applies.)

There has been a proceeding concerning the conviction before a hearing of the State of Florida, Division of Administrative Hearings. The final order entered by the hearing officer did not place the person or affiliate on the convicted vendor list. (Please attach a copy of the final order.)

The person or affiliate was placed on the convicted vendor list. There has been a subsequent proceeding before a hearing officer of the State of Florida, Division of Administrative Hearings. The final order entered by the hearing officer determined that it was in the public interest to remove the person or affiliate from the convicted vendor list. (Please attach a copy of the final order.)

The person or affiliate has not been put on the convicted vendor list. (Please describe any action taken by or pending with the Department of General Services.)

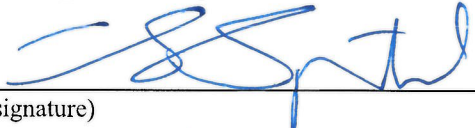
 (signature)

5/25/23
 (date)

STATE OF Florida

COUNTY OF Monroe

PERSONALLY APPEARED BEFORE ME, the undersigned authority,

Charles Spottswood who, after first being sworn by me, affixed his/her
 (name of individual signing)

signature in the space provided above on this 25 day of May, 2023.

My commission expires: Feb 14, 2026



 NOTARY PUBLIC

CITY OF KEY WEST INDEMNIFICATION FORM

To the fullest extent permitted by law, the CONTRACTOR expressly agrees to indemnify and hold harmless the City of Key West, their officers, directors, agents and employees *(herein called the "indemnitees") from liabilities, damages, losses and costs, including but not limited to, reasonable attorney's fees and court costs, such legal expenses to include costs incurred in establishing the indemnification and other rights agreed to in this Paragraph, to persons or property, to the extent caused by the negligence, recklessness, or intentional wrongful misconduct of the CONTRACTOR, its Subcontractors or persons employed or utilized by him/ her in the performance of the Contract. Claims by indemnitees for indemnification shall be limited to the amount of CONTRACTOR's insurance or \$2 million per occurrence, whichever is greater. The parties acknowledge that the amount of the indemnity required hereunder bears a reasonable commercial relationship to the Contract and it is part of the project specifications or the bid documents, if any.

The indemnification obligations under the Contract shall not be restricted in any way by any limitation on the amount or type of damages, compensation, or benefits payable by or for the CONTRACTOR under Workers' Compensation acts, disability benefits acts, or other employee benefits acts, and shall extend to and include any actions brought by or in the name of any employee of the CONTRACTOR or of any third party to whom CONTRACTOR may subcontract a part or all of the Work. This indemnification shall continue beyond the date of completion of the work.

CONTRACTOR: 506 Fleming St, Key West, FL 33040

SEAL:

Address

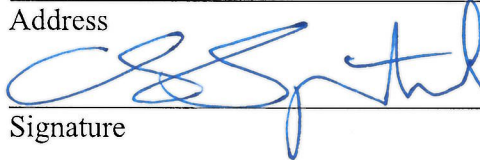

Signature

Charles Spottswood

Print Name

Co-President

Title

DATE:

5/25/23

EQUAL BENEFITS FOR DOMESTIC PARTNERS AFFIDAVIT

STATE OF Florida)

: SS

COUNTY OF Monroe)

I, the undersigned hereby duly sworn, depose and say that the firm of Keystar, Inc.

provides benefits to domestic partners of its employees on the same basis as it provides benefits to employees' spouses, per City of Key West Code of Ordinances Sec. 2-799.

By

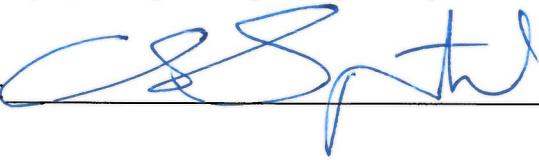

Sworn and subscribed before me this 25 day of May 2023.

NOTARY PUBLIC, State of Florida at Large



My Commission Expires: Feb 14, 2026

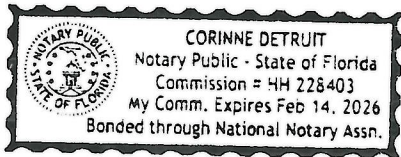

* * * * *

CONE OF SILENCE AFFIDAVIT

STATE OF Florida)

: SS

COUNTY OF Monroe)

I, the undersigned hereby duly sworn, depose and say that all owner(s), partners, officers, directors, employees and agents representing the firm of Keystar, Inc. have read and understand the limitations and procedures regarding communications concerning City of Key West Code of Ordinances Sec. 2-773 Cone of Silence.

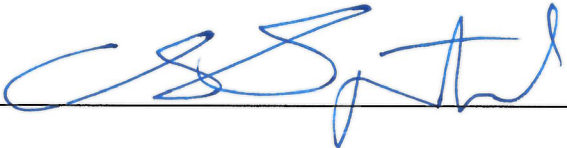
By: 

Sworn and subscribed before me this

25 day of May 2023.



NOTARY PUBLIC, State of Florida at Large

My Commission Expires: Feb 14, 2026

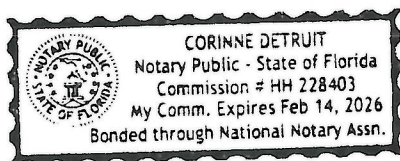

**LOCAL VENDOR FORM
PURSUANT TO CITY OF KEY WEST CODE OF ORDINANCES SECTION 2-798**

The undersigned, as a duly authorized representative of the vendor listed herein, certifies to the best of his/her knowledge and belief, that the vendor meets the definition of a "Local Business." For purposes of this section, "local business" shall mean a business which:

- a. Principle address as registered with the FL Department of State located within 30 miles of the boundaries of the city, listed with the chief licensing official as having a business tax receipt with its principle address within 30 miles of the boundaries of the city for at least one year immediately prior to the issuance of the solicitation.
- b. Maintains a workforce of at least 50 percent of its employees from the city or within 30 miles of its boundaries.
- c. Having paid all current license taxes and any other fees due the city at least 24 hours prior to the publication of the call for bids or request for proposals.
 - o Not a local vendor pursuant to Code of Ordinances Section 2-798
 - o Qualifies as a local vendor pursuant to Code of Ordinances Section 2-798

If you qualify, please complete the following in support of the self-certification & submit copies of your County and City business licenses. Failure to provide the information requested will result in denial of certification as a local business.

Business Name Keystar, Inc. Phone: 305-517-6270

Current Local Address: 506 Fleming St Fax:
(P.O Box numbers may not be used to establish status)
Key West, FL 33040

Length of time at this address 24 years



Signature of Authorized Representative

5/25/23
Date

STATE OF Florida
COUNTY OF Monroe

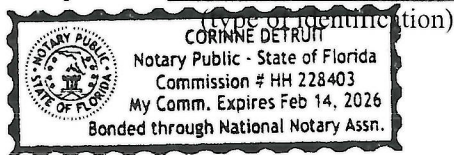
The foregoing instrument was acknowledged before me this 25 day of May, 2023.
By Charles Spottswood, President, of Keystar, Inc
(Name of officer or agent, title of officer or agent) Name of corporation acknowledging)
or has produced _____ as identification

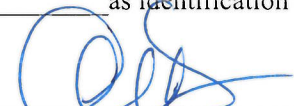

Signature of Notary
Corinne M Detruit
Print, Type or Stamp Name of Notary
Admin manager
Title or Rank

Return Completed form with
Supporting documents to:
City of Key West Purchasing

VENDOR CERTIFICATION REGARDING SCRUTINIZED COMPANIES LISTS

Respondent Vendor Name: <u>Keystar, Inc.</u>		
Vendor FEIN: <u>65-0866227</u>		
Vendor's Authorized Representative Name and Title: <u>Charles Spottswood, Co-President</u>		
Address: <u>506 Fleming St</u>		
City: <u>Key West</u>	State: <u>FL</u>	Zip: <u>33040</u>
Phone Number: <u>305-517-6270</u>		
Email Address: <u>Chas@keystarconstruction.com</u>		

Section 287.135(2)(a), Florida Statutes, prohibits a company from bidding on, submitting a proposal for, or entering into or renewing a contract for goods or services of any amount if, at the time of contracting or renewal, the company is on the Scrutinized Companies that Boycott Israel List, created pursuant to section 215.4725, Florida Statutes, or is engaged in a boycott of Israel. Section 287.135(2)(b), Florida Statutes, further prohibits a company from bidding on, submitting a proposal for, or entering into or renewing a contract for goods or services over one million dollars (\$1,000,000) if, at the time of contracting or renewal, the company is on either the Scrutinized Companies with Activities in Sudan List or the Scrutinized Companies with Activities in the Iran Petroleum Energy Sector List, both created pursuant to section 215.473, Florida Statutes, or the company is engaged in business operations in Cuba or Syria.

As the person authorized to sign on behalf of Respondent, I hereby certify that the company identified above in the section entitled "Respondent Vendor Name" is not listed on either the Scrutinized Companies that Boycott Israel List, Scrutinized Companies with Activities in Sudan List or the Scrutinized Companies with Activities in the Iran Petroleum Energy Sector List I understand that pursuant to section 287.135, Florida Statutes, the submission of a false certification may subject such company to civil penalties, attorney's fees, and/or costs and termination of the contract at the option of the awarding governmental entity.

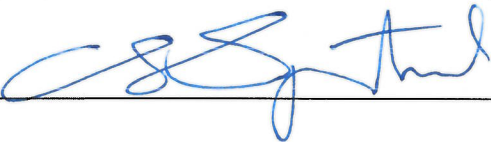
Certified By: <u>Charles Spottswood</u>	<u>Co-President</u>
<i>Print Name</i>	<i>Print Title</i>
who is authorized to sign on behalf of the above referenced company.	
Authorized Signature: 	



THE CITY OF KEY WEST

Post Office Box 1409 Key West, FL 33041-1409 (305) 809-3883

ADDENDUM NO. 1

Frederick Douglass Community Center – ITB 23-005

This addendum is issued as supplemental information to the bid package for clarification of certain matters of both a general and a technical nature. The referenced Request for Proposal (RFP) package is hereby amended in accordance with the following items:

City: Requests for Information and Clarifications:

1. Permit fees are unknown – will an allowance or exclusion of fees be acceptable?
 - a. Add an allowance of \$125,000 for permit fees.
2. Bid invitation page 12 states 545 calendar days for completion. Page 18 states 440. Which is correct?
 - a. Please use 545 calendar days.
3. Has an asbestos Survey been performed? If so, please provide. If not, will Owner perform or GC?
 - a. City to provide asbestos/ lead paint test results prior to demolition of the building.
4. Bid docs state we agree to Florida Green Comm. Building – will this building need to be certified?
 - a. Yes, the building is required to be a min. of a bronze certification. City to complete paperwork.
5. Bid Docs state if there's an event scheduled, we have to stop construction if there's interference. Is there a calendar of events we can review to see how many days will be affected by these events?
 - a. Plan for (2) Friday shut-downs for Goombay Festival that happen the weekend before Halloween.
6. Add Alternate for solar form states total of A-B. Shouldn't this read A-C?
 - a. No change to the bid form is needed.
7. Will the Owner be responsible for Health Dept. application and review/fees?
 - a. City to coordinate with the health dept. for review and fees that are needed.
8. ITB page 21 regarding Solar add alternate references Roof Plan A2.3.1. We understand it is a design build system but what are the solar panels on E2.0.2 for? Just for reference?
 - a. Ignore the solar panels on E2.02
9. Please verify low voltage data, cameras, access systems are supplied and installed by Owner.
 - a. Owner/ City to supply and install low voltage data, cameras, access systems. Contractor to coordinate with owner's contractor.

Attachments:

1. Pre-Bid Sign-in Sheet_FDCC
2. For Reference Only_2018 Renovation Drawings
3. Geo Tech Report_FDCC
4. K2M- RFI response_AD01
5. Bike Bollard
6. AFC_48x75_20-0429.01
7. DuraShutter- Overhead Door
8. DuraShutter Standard Spec Sheet
9. Solar Study_FDCC
10. AED Specification

All Bidders shall acknowledge receipt and acceptance of this Addendum No. 1 with Attachment by submitting the addendum with their proposal. Proposals submitted without acknowledgement or without this Addendum may be considered non-responsive.

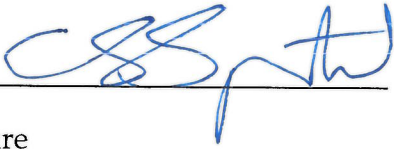
A handwritten signature in blue ink, appearing to be 'C. S. Smith', written over a horizontal line.

Signature

The handwritten business name 'Keystar, inc' in blue ink, written over a horizontal line.

Name of Business



THE CITY OF KEY WEST

Post Office Box 1409 Key West, FL 33041-1409 (305) 809-3883

ADDENDUM NO. 2

Frederick Douglass Community Center – ITB 23-005

This addendum is issued as supplemental information to the bid package for clarification of certain matters of both a general and a technical nature. The referenced Request for Proposal (RFP) package is hereby amended in accordance with the following items:

- 1. City Update:** Revise the contract documents bid dates as outlined below:

FREDERICK DOUGLASS COMMUNITY CENTER(FDCC)

SUBJECT: INVITATION TO BID NO. 23-005:
CITY OF KEY WEST
Frederick Douglass Community Center (FDCC)

ISSUE DATE: March 31, 2023

MAIL OR SPECIAL
DELIVERY REPOSSES TO: CITY CLERK
CITY OF KEY WEST
1300 WHITE STREET
KEY WEST, FL 33040

DELIVER BIDS TO: SAME AS ABOVE.

FIRST DATE FOR INQUIRIES: April 11, 2023

MANDATORY PRE-BID: April 18, 2023

FINAL DATE FOR INQUIRIES: ~~May 8, 2023~~ May 15, 2023

FINAL DATE FOR RESPONSES: ~~May 12, 2023~~ May 19, 2023

BIDS MUST BE RECEIVED: ~~May 24, 2023~~ May 30, 2023

NOT LATER THAN: 3:00 P.M. LOCAL TIME

2. Revise the Contract Documents bid date on Page 6 as outlined below:

INVITATION TO BID

Sealed bids for the City of Key West **ITB #23-005 FREDERICK DOUGLASS COMMUNITY CENTER(FDCC)**, addressed to the City of Key West, will be received at the Office of the City Clerk, 1300 White St., Key West Florida, 33040 until **3:00 pm on MAY 30~~24~~, 2023** and then will be publicly opened and read. Any bids received after the time and date specified will not be considered.

3. See attached RFI's answered by K2M Design, LLC
4. Fence- located between the proposed building and existing building to be 6' high metal picket (black finish). Match City Hall Fence located at 1300 White street, located between buildings. [Click here for street view](#) from Seminary St.

Attachments:

1. K2M- RFI response_AD02

All Bidders shall acknowledge receipt and acceptance of this Addendum No. 1 with Attachment by submitting the addendum with their proposal. Proposals submitted without acknowledgement or without this Addendum may be considered non-responsive.



Signature



Name of Business



THE CITY OF KEY WEST

Post Office Box 1409 Key West, FL 33041-1409 (305) 809-3883

ADDENDUM NO. 3

Frederick Douglass Community Center – ITB 23-005

This addendum is issued as supplemental information to the bid package for clarification of certain matters of both a general and a technical nature. The referenced ITB 23-005 package is hereby amended in accordance with the following items:

1. Revised Bid Schedule language, page 19 of Contract Documents- “The Bidder shall submit a Schedule of Values, upon request from the City, on May 30, 2023”.
Clarification, a schedule of Values is not required with the bid but may be requested by the City after the bids are received.
2. Revised Add Alternate for Solar Power System, Bid Form pages 21 & 22, See attachments. A separate line item was requested for Design- build electrical upgrades to the system. If you do not require this as part of your bid, you can put down NA for not applicable. Also revised lump sum for 20.a-20.c and the total cost for 20.a-20.i.
3. Clarification from AD01- Question 42 & 44.
Contractor to provide an allowance of \$15,000 as a line item in the base bid, for projectors.
4. See attachment for final K2M- RFI questions. No additional RFI’s will be reviewed but if you have a question on AD03, please email City PM as soon as possible.

Attachments:

1. Revised Add Alternate for Solar Power System, Bid Form
2. K2M- RFI response_AD03

All Bidders shall acknowledge receipt and acceptance of this Addendum No. 1 with Attachment by submitting the addendum with their proposal. Proposals submitted without acknowledgement or without this Addendum may be considered non-responsive.

A handwritten signature in blue ink, appearing to be "J. S. [unclear]", written over a horizontal line.

Signature

A handwritten signature in blue ink that reads "Keystar, inc", written over a horizontal line.

Name of Business

CITY OF KEY WEST, FLORIDA

Business Tax Receipt

This Document is a business tax receipt
Holder must meet all City zoning and use provisions.
P.O. Box 1409, Key West, Florida 33040 (305) 809-3955

Business Name KEYSTAR INC
Location Addr 506 FLEMING ST
Lic NBR/Class 10636 CONTRACTOR DBPR STATE CERTIFIED
Issued Date 8/2/2022 **Expiration Date: September 30, 2023**

GENERAL CONTRACTOR

Comments:

Restrictions: CGC1522391 (08/31/22)

KEYSTAR INC
506 FLEMING ST

KEY WEST, FL 33040

This document must be prominently displayed.

SPOTTSWOOD, WILLIAM (PRES)

License #10636

 Attachment

License Info

Additional Info

Fees \$0.00

Chronology (4)

License No: 10636
Licensee Name: KEYSTAR INC
Type: CONTRACTOR DBPR STATE CERTIFIED
SubType: GENERAL CONTRACTOR
OWNERSHIP CORPORATION
Status: ACTIVE
Issued: 8/2/2022
License Expire: 9/30/2023
Applied: 4/15/1995



Ron DeSantis, Governor

Melanie S. Griffin, Secretary



STATE OF FLORIDA
DEPARTMENT OF BUSINESS AND PROFESSIONAL REGULATION

CONSTRUCTION INDUSTRY LICENSING BOARD

THE GENERAL CONTRACTOR HEREIN IS CERTIFIED UNDER THE
PROVISIONS OF CHAPTER 489, FLORIDA STATUTES

SPOTTSWOOD, CHARLES CHRISTMANN

KEYSTAR, INC.
506 FLEMING ST.
KEY WEST FL 33040

LICENSE NUMBER: CGC1522391

EXPIRATION DATE: AUGUST 31, 2024

Always verify licenses online at MyFloridaLicense.com



Do not alter this document in any form.

This is your license. It is unlawful for anyone other than the licensee to use this document.