

RESOLUTION NO. 11-185

A RESOLUTION OF THE CITY COMMISSION OF THE CITY OF KEY WEST, FLORIDA, AWARDING THE BID OF CHARLEY TOPPINO & SONS, INC., FOR THE CONSTRUCTION OF COLLEGE ROAD ENHANCEMENTS (PROJECT GN-0711) IN AN AMOUNT NOT TO EXCEED \$279,841.99; PROVIDING FOR AN EFFECTIVE DATE

WHEREAS, in Resolution 08-102, and amended in Resolution 10-234, the City Commission approved a Department of Transportation Local Agency Program Agreement (LAP) for the construction of College Road Enhancements; and

WHEREAS, staff reviewed the bids received in response to Project No. GN-0711, and recommended acceptance of the lowest responsive bid, submitted by Charley Toppino & Sons, Inc.;

NOW, THEREFORE, BE IT RESOLVED BY THE CITY COMMISSION OF THE CITY OF KEY WEST, FLORIDA, AS FOLLOWS:

Section 1: That the bid of Charley Toppino & Sons, Inc. in an amount not to exceed \$279,841.99 is hereby awarded and the City Manager is authorized to enter into an agreement in conformity with the LAP agreement and bid documents with the advice and consent of the city attorney.

Section 2: That this Resolution shall go into effect immediately upon its passage and adoption and authentication by the signature of the presiding officer and the Clerk of the Commission.

Passed and adopted by the City Commission at a meeting held this 21 day of June, 2011.

Authenticated by the presiding officer and Clerk of the Commission on June 22, 2011.

Filed with the Clerk June 22, 2011.

CRAIG CATES, MAYOR

ATTEST:

CHERYL SMITH, CITY CLERK



THE CITY OF KEY WEST

Post Office Box 1409 Key West, FL 33041-1409 (305) 809-3700

M
E
M
O
R
A
N
D
U
M

EXECUTIVE SUMMARY

TO: Jim Scholl, City Manager
E. David Fernandez, Asst. City Manager
Mark Finigan, Asst. City Manager
Doug Bradshaw, Senior Project Manager

FROM: Janet Muccino, Project Manager

DATE: May 2, 2011

SUBJECT: Awarding the bid for the College Road Enhancements to Charley Toppino & Sons in the amount of \$279,841.99.

ACTION STATEMENT:

This resolution will approve awarding the College Road Enhancements project to Charley Toppino & Sons, Inc. (CTS) in the amount of \$279,841.99. Award still requires concurrence from Florida Department of Transportation (FDOT) following City Commission approval.

BACKGROUND:

Two bids were received in response to the Invitation to Bid for the College Road Enhancements project on April 13, 2011. The low base bid submitted from CTS was \$260,207.31. D.N. Higgins base bid was \$319,000.

There were four additive/alternates (add/alts) in the bid including seepage trench, stripping, bus shelters, and gravel. The CTS bid for the add/alts was \$37,090.94. The base bid plus the add/alts equals \$297,298.25 which is \$11,198.25 over the budgeted amount; however, two (2) bus shelters included as an add/alt line item will now be supplied by the City's current shelter advertiser Anderson Outdoor Advertising at no cost to the City. This will save the City \$17,456.26 and bring the total CTS bid to \$279,841.99 which is within the \$286,100 construction budget of the grant.

PURPOSE & JUSTIFICATION:

The new sidewalk to be installed is on the north side of College Road and will alleviate congestion on the existing bike path and provide a safer route for those on foot. The project will involve sidewalk installation and minor drainage improvements. This is a LAP project

Key to the Caribbean – Average yearly temperature 77° F.

that was approved by Resolution 08-102 and revised by Resolution 10-234

OPTIONS:

1. Approve the award of the low bid to CTS to construct the College Road Enhancements in the amount of \$279,841.99. This will allow the City to provide sidewalk improvements to College Road thus improving the safety of pedestrians. The bid is within the budget.
2. Reject all bids received on April 13, 2011 and rebid the project.

FINANCIAL IMPACT:

The College Rd. project GN 0711 is fully funded from account 102-4104-541-6300 and will be reimbursed 100% through an FDOT Local Area Program (LAP) grant. Currently, a LAP Agreement is in place for this project with design funds of \$42,500, construction funds of \$286,100 and Construction Engineering and Inspection (CEI) of \$31,360 for a total grant amount of \$359,960 (no City match required).

RECOMMENDATION:

Staff recommends the City Commission approve the award of the low bid from CTS in the amount of \$279,841.99 to construct the College Road Enhancements.

College Road Enhancements
 Bid Check Sheet

Line #	Line Item	Qty	Unit	Charley Toppino & Sons		DN Higgins	
				Unit Price	Extended Total	Unit Price	Extended Total
1	Performance and Payment Bonds	1	LS	\$ 4,872.00	\$ 4,872.00	\$ 3,700.00	\$ 3,700.00
2	Mobilization/Demobilization, FDOT Grant Requirements, Gen&Supp Conditions, MOT, Cert. AutoCAD As-Builts						
2a	Mobilization/Field Engineering/Testing/Environmental Constr. Layout/pre-constr. Video	1	LS	12,500.00	12,500.00	15,200.00	15,200.00
2b	Demobilization	1	LS	6,250.00	6,250.00	5,400.00	5,400.00
2c	FDOT Grant Requirements, Gen&Supp Conditions	1	LS	17,625.00	17,625.00	17,544.00	17,544.00
2d	MOT	1	LS	26,700.00	26,700.00	22,000.00	22,000.00
2e	Certified AutoCAD As-builts/Surveyor	1	LS	4,375.00	4,375.00	4,400.00	4,400.00
3	Clearing and grubbing	0.98	AC	11,352.04	11,125.00	22,000.00	21,560.00
4	Sidewalk Installation						
4a	4" Depth	974	SY	54.40	52,985.60	88.00	85,712.00
4b	6" Depth	199	SY	76.99	15,321.01	104.00	20,696.00
4c	Thickened Edge	3362	LF	11.15	37,486.30	16.00	53,792.00
4d	Bridged sidewalk over ditch bottom inlet	5	CY	850.00	4,250.00	610.00	3,050.00
5	Curb Installation						
5a	FDOT Type "F"	50	LF	43.75	2,187.50	46.00	2,300.00
5b	Flared and curb	1	EA	250.00	250.00	125.00	125.00
6	Guardrail	35	LF	140.04	4,901.40	165.00	5,775.00
7	Asphalt/SP 9.5/1.5"	50	SY	81.25	4,062.50	120.00	6,000.00
8	Utility Adjustments						
8a	Adjust water valves/boxes (FKAA) vertically and/or laterally	3	EA	312.50	937.50	185.00	555.00
9	Silt Fence	415	LF	2.50	1,037.50	3.00	1,245.00
10	Plastic Delineators - flexible tubing	20	EA	75.00	1,500.00	67.00	1,340.00
11	ADAAG Detectable Warning System	12	SF	37.50	450.00	128.00	1,536.00
12	Sodding	3200	SY	5.63	18,016.00	4.75	15,200.00
13	Remove Existing Trees/Strubs (0-10" Diameter)	4	EA	250.00	1,000.00	130.00	520.00
14	Remove Existing Tree (over 10" Diameter)	2	EA	625.00	1,250.00	150.00	300.00
15	Business Sign relocation	3	EA	375.00	1,125.00	350.00	1,050.00
16	Allowance	1	LS	30,000.00	30,000.00	30,000.00	30,000.00
	TOTAL BID SCHEDULE ITEMS 1 TO 16				\$ 260,207.31		\$ 319,000.00
Add/Alt 1	Seepage Trench	100	LF	87.75	8,775.00	73.25	7,325.00
Add/Alt 2	Striping	0.6	NM	8,392.80	5,035.68	5,325.00	3,195.00
Add/Alt 3	Bus Shelters	2	EA	8,728.13	17,456.26	7,400.00	14,800.00
Add/Alt 4	Gravel Stone 1/2 inch to 3/4 inch diameter	65	TONS	89.60	5,824.00	86.00	5,590.00
	TOTAL BID SCHEDULE ITEMS 1 TO 16 PLUS ADD/ALTS 1 - 4				\$ 297,296.25		\$ 349,910.00

CONTRACT

This Contract, made and entered into this 20 day of July 2011,

by and between the City of Key West, hereinafter called the "Owner", and _____
Charley Toppino & Sons

hereinafter called the "Contractor";

WITNESSETH:

The Contractor, in consideration of the sum to be paid him by the Owner and of the covenants and agreements herein contained, hereby agrees at his own proper cost and expense to do all the work and furnish all the materials, tools, labor, and all appliances, machinery, and appurtenances for COLLEGE ROAD ENHANCEMENTS, OVERSEAS HIGHWAY TO KOKENZIE ROAD, GN 0711, Key West, Florida to the extent of the Proposal made by the Contractor, dated the 19 day of March, 2011, all in full compliance with the Contract Documents referred to herein.

The BIDDING REQUIREMENTS, including the signed copy of the PROPOSAL, the CONTRACT FORMS, PERFORMANCE and PAYMENT BONDS, the CONDITIONS OF THE CONTRACT, the SPECIFICATIONS, and the DRAWINGS.

In consideration of the performance of the work as set forth in these Contract Documents, the Owner agrees to pay to the Contractor the amount bid in the Proposal as adjusted in accordance with the Contract Documents, or as otherwise herein provided, and to make such payments in the manner and at the times provided in the Contract Documents.

The Contractor agrees to complete the work within the time specified in the Contract and to accept as full payment hereunder the amounts computed as determined by the Contract Documents and based on the said Proposal.

The Contractor agrees to remedy all defects appearing in the work or developing in the materials furnished and the workmanship performed under this Contract during the warranty period after the date of final acceptance of the work by the Owner, and further agrees to indemnify and save the Owner harmless from any costs encountered in remedying such defects.

It is agreed that the Contract, based upon the Proposal, shall be fully complete within the stated number of consecutive calendar days from the date the Notice to Proceed is issued..

In the event the Contractor and fails to complete the work within the time limit or extended time limit agreed upon, as more particularly set forth in the Contract Documents, liquidated damages shall be paid to the Owner based on the current FDOT Standard Specifications Section 8-10 until the work has been satisfactorily completed as provided by the Contract Documents. Sundays and legal holidays shall be included in determining days in default. FDOT 8-10 Code requirements govern, and herewith made a part of the Contract.

Original Contract Amount	Daily Charge Per Calendar Day
\$50,000 and Under	\$313
Over \$50,000 but less then \$250,000	\$580
\$250,000 but less than \$500,000	\$715
\$500,000 but less than \$2,500,000	\$1,423
\$2,500,000 but less than \$5,000,000	\$2,121
\$5,000,000 but less than \$10,000,000	\$3,057

It is agreed the Contract, Base of the Proposal, shall be fully complete within 120 consecutive calendar days as stated in the notice to proceed.

IN WITNESS WHEREOF, we, the parties hereto, each herewith subscribe the same this

20TH day of JULY, A.D., 2011.

CITY OF KEY WEST

By J. K. Schell

Title CITY MANAGER

CONTRACTOR

By Frank P. Jarama

Title President

PERFORMANCE BOND

BOND NO. 1949760

AMOUNT: \$ 279,841.99

KNOW ALL MEN BY THESE PRESENTS, that in accordance with Florida Statutes Section 255.05,

Charley Toppino & Sons, Inc.

with offices at 8 1/2 Rockland Key, Key West, FL 33040
hereinafter called the CONTRACTOR (Principal), and

The Hanover Insurance Company

with offices at 440 Lincoln Street, Worcester, MA 01653

a corporate duly organized and existing under and by virtue of the laws of the State of NH hereinafter called the SURETY, and authorized to transact business within the State of Florida, as SURETY, are held and firmly bound unto **CITY OF KEY WEST**, represented by its _____, hereinafter called the CITY (Obligee), in the sum of:

Two Hundred Seventy Nine Thousand Eight Hundred Forty One and 99/100 DOLLARS (\$ 279,841.99), lawful money of the United States of America, for the payment of which, well and truly be made to the CITY, the CONTRACTOR and the SURETY bind themselves and each of their heirs, executors, administrators, successors, and assigns, jointly and severally, firmly by these presents as follows:

THE CONDITION OF THE ABOVE OBLIGATION IS SUCH THAT:

WHEREAS, the CONTRACTOR has executed and entered into a certain Contract hereto attached, with the CITY, dated July 13, 2011, to furnish at his own cost, charges, and expense all the necessary materials, equipment, and/or labor in strict and express accordance with said Contract and the Contract Documents as defined therein, all of which is made a part of said Contract by certain terms and conditions in said Contract more particularly mentioned, which Contract, consisting of the various Contract Documents is made a part of this Bond as fully and completely as if said Contract Documents were set forth herein;

NOW THEREFORE, the conditions of this obligation are such that if the above bounden CONTRACTOR:

1. Shall in all respects comply with the terms and conditions of said Contract and his obligation thereunder, including the Contract Documents, being made a part of this bond by reference, at the times and in the manner prescribed in the contract; and
2. Promptly makes payments to all claimants, as defined in Section 255.05(1), Florida Statutes, supplying CONTRACTOR with labor, materials, or supplies, used directly or indirectly by CONTRACTOR in the prosecution of the work provided for in the contract; and

3. Pays CITY all losses, costs, expenses, damages, attorney's fees, including appellate proceedings, injury or loss of whatever kind and however arising including, without limitation, delay damages to which said CITY may be subject by reason of any wrongdoing, misconduct, want of care or skill, negligence, failure of performance, breach, failure to petition within the prescribed time, or default, including patent infringements, on the part of said CONTRACTOR, his agents or employees, in the execution or performance of said Contract; and

4. Performs the guarantee of all work and materials furnished under the contract for the time specified in the contract, then this obligation shall be void; otherwise, to remain in full force and effect for the term of said Contract.

AND, the said Surety for value received, hereby stipulates and agrees that no change involving any extension of time, or addition to the terms of the Contract Documents, or to the work to be performed, or materials to be furnished thereunder shall affect said obligation of said Surety on this Bond, and the said Surety does hereby waive notice of any such changes, extension of time, alterations, or additions of the terms of the Contract Documents, or to the work.

Any action instituted by a claimant under this bond for payment must be in accordance with the notice and time limitation provisions in Section 255.05(2), Florida Statutes.

IN WITNESS WHEREOF, the above parties bounded together have executed this instrument this 13th day of July, 2011, 2011, the name and corporate seal of each corporate party being hereto affixed and those presents duly signed by its undersigned representative, pursuant to authority of its governing body.

Charley Toppino & Sons, Inc.

CONTRACTOR

By:

Frank P. Jappo

(SEAL)

ATTEST

Paul R. Jappo Const Sec'y

The Hanover Insurance Company

SURETY

By:

William L. Parker Attorney in Fact & FL Resident Agent

(SEAL)

ATTEST

William L. Parker

PAYMENT BOND

BOND NO. 1949760

AMOUNT: \$279,841.99

KNOW ALL MEN BY THESE PRESENTS, that in accordance with Florida Statutes Section 255.05,

Charley Toppino & Sons, Inc.

with offices at 8 1/2 Rockland Key, Key West, FL 33040
hereinafter called the CONTRACTOR, (Principal), and

The Hanover Insurance Company

with offices at 440 Lincoln Street, Worcester, MA 01653
a corporation duly organized and existing under and by virtue of the laws of the State of

NH, hereinafter called the SURETY, and authorized to transact business
within the State of Florida, as SURETY, are held and firmly bound CITY OF KEY WEST, represented

by its _____, hereinafter called the City (Obligee), in the sum of:

Two Hundred Seventy Nine Thousand Eight Hundred Forty One and 99/100 DOLLARS (\$ 279,841.99), lawful money of the
United States of America, for the payment of which, well and truly be made to the CITY, and the
CONTRACTOR and the SURETY bind themselves and each of their heirs, executors, administrators,
successors, and assigns, jointly and severally, firmly by these presents as follows:

THE CONDITION OF THE ABOVE OBLIGATION IS SUCH THAT:

WHEREAS, the CONTRACTOR has executed and entered into a certain Contract for
College Road Enhancements attached hereto, with the CITY, dated July 13,

_____, 2011, to furnish at his own cost, charges, and expense the
necessary materials, equipment, and/or labor in strict and express accordance with said Contract and the
plans, drawings (if any), and specifications prepared by the CITY, all of which is made a part of said
Contract by certain terms and conditions in said Contract more particularly mentioned, which Contract,
consisting of the various Contract Documents specifically mentioned herein and relative hereto, is made
a part of this Bond as fully and completely as if said Contract Documents were set forth herein.

NOW THEREFORE, the conditions of this obligation are such that if the above bounden
CONTRACTOR shall in all respects comply with the terms and conditions of said Contract and his
obligation thereunder, including the Contract Documents (which include the plans, drawings,
specifications, and conditions prepared by the CITY, invitation to bid, instructions to bidders, the
CONTRACTOR'S bid as accepted by the CITY, the bid and contract and payment bonds, and all

GN 0711

This bond is given to comply with section 46 255.05
Florida Statutes, and any action instituted by a claimant
under this bond for payment must be in accordance
with the notice and time limitation provisions in
Section 255.05 (2), Florida Statutes.

College Road Enhancements
Payment Bond

addenda, if any, issued prior to the opening of bids), and further that if said CONTRACTOR shall promptly make payments to all persons supplying materials, equipment, and/or labor, used directly or indirectly by said CONTRACTOR or subcontractors in the prosecution of the work for said contract in accordance with Florida Statutes, Section 255.05 or Section 713.23, then this obligation shall be void; otherwise to remain in full force and effect for the term of said contract, including and all guarantee periods as specifically mentioned in said Contract Documents.

AND, the said SURETY for value received, hereby stipulates and agrees that no change involving any extension of time, or addition to the terms of the Contract or to the work to be performed, or materials to be furnished thereunder, or in the Contract Documents and specifications accompanying the said contract shall affect said obligation of said SURETY on this Bond, and the said SURETY does hereby waive notice of any such changes, extension of time, alternations, or additions of the terms of the Contract, or to the work, to the Contract Documents, or to the specifications.

Claimant shall give written notice to the CONTRACTOR and the SURETY as required by Section 255.05 or Section 713.23, Florida Statutes. Any action instituted against the CONTRACTOR or SURETY under this bond for payment must be in accordance with the notice and time limitation provisions in Section 255.05(2) or Section 713.23, Florida Statutes.

13th IN WITNESS WHEREOF, the above parties bounded together have executed this instrument this day of July, 2011, 2011, the name and corporate seal of each corporate party being hereto affixed and those presents duly signed by its undersigned representative, pursuant to authority of its governing body.



Charley Toppino & Sons, Inc.
CONTRACTOR

By: Frank P. Toppino

ATTEST

[Handwritten signature]

SURETY The Hanover Insurance Company

By:

[Handwritten signature]

William L. Parker, Attorney in Fact & FL Resident Agent

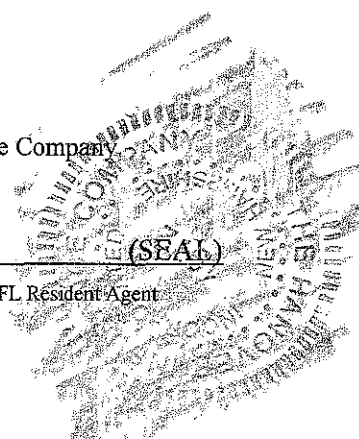

ATTEST

[Handwritten signature]

THE HANOVER INSURANCE COMPANY
MASSACHUSETTS BAY INSURANCE COMPANY
CITIZENS INSURANCE COMPANY OF AMERICA

POWERS OF ATTORNEY
CERTIFIED COPY

KNOW ALL MEN BY THESE PRESENTS: That THE HANOVER INSURANCE COMPANY and MASSACHUSETTS BAY INSURANCE COMPANY, both being corporations organized and existing under the laws of the State of New Hampshire, and CITIZENS INSURANCE COMPANY OF AMERICA, a corporation organized and existing under the laws of the State of Michigan, do hereby constitute and appoint
Charles C. Ball, Ileana M. Bauza, William F. Kleis, Davor I. Mimica and/or William L. Parker

of Miami, FL and each is a true and lawful Attorney(s)-in-fact to sign, execute, seal, acknowledge and deliver for, and on its behalf, and as its act and deed any place within the United States, or, if the following line be filled in, only within the area therein designated

any and all bonds, recognizances, undertakings, contracts of indemnity or other writings obligatory in the nature thereof, as follows:
Any such obligations in the United States, not to exceed Twenty Million and No/100 (\$20,000,000) in any single instance

and said companies hereby ratify and confirm all and whatsoever said Attorney(s)-in-fact may lawfully do in the premises by virtue of these presents. These appointments are made under and by authority of the following Resolution passed by the Board of Directors of said Companies which resolutions are still in effect:

"RESOLVED, That the President or any Vice President, in conjunction with any Assistant Vice President, be and they are hereby authorized and empowered to appoint Attorneys-in-fact of the Company, in its name and as its acts, to execute and acknowledge for and on its behalf as Surety any and all bonds, recognizances, contracts of indemnity, waivers of citation and all other writings obligatory in the nature thereof, with power to attach thereto the seal of the Company. Any such writings so executed by such Attorneys-in-fact shall be as binding upon the Company as if they had been duly executed and acknowledged by the regularly elected officers of the Company in their own proper persons." (Adopted October 7, 1981 - The Hanover Insurance Company; Adopted April 14, 1982 - Massachusetts Bay Insurance Company; Adopted September 7, 2001 - Citizens Insurance Company of America)

IN WITNESS WHEREOF, THE HANOVER INSURANCE COMPANY, MASSACHUSETTS BAY INSURANCE COMPANY and CITIZENS INSURANCE COMPANY OF AMERICA have caused these presents to be sealed with their respective corporate seals, duly attested by a Vice President and an Assistant Vice President, this 8th day of July 2009.



THE HANOVER INSURANCE COMPANY
MASSACHUSETTS BAY INSURANCE COMPANY
CITIZENS INSURANCE COMPANY OF AMERICA

Mary Jeanne Anderson
Mary Jeanne Anderson, Vice President

Robert K. Grennan
Robert K. Grennan, Assistant Vice President

THE COMMONWEALTH OF MASSACHUSETTS)
COUNTY OF WORCESTER) ss.

On this 8th day of July 2009, before me came the above named Vice President and Assistant Vice President of The Hanover Insurance Company, Massachusetts Bay Insurance Company and Citizens Insurance Company of America, to me personally known to be the individuals and officers described herein, and acknowledged that the seals affixed to the preceding instrument are the corporate seals of The Hanover Insurance Company, Massachusetts Bay Insurance Company and Citizens Insurance Company of America, respectively, and that the said corporate seals and their signatures as officers were duly affixed and subscribed to said instrument by the authority and direction of said Corporations.

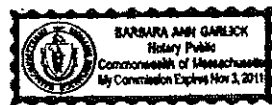

Barbara A. Garlick
Notary Public

My commission expires on November 3, 2011

I, the undersigned Assistant Vice President of The Hanover Insurance Company, Massachusetts Bay Insurance Company and Citizens Insurance Company of America, hereby certify that the above and foregoing is a full, true and correct copy of the Original Power of Attorney issued by said Companies, and do hereby further certify that the said Powers of Attorney are still in force and effect.

This Certificate may be signed by facsimile under and by authority of the following resolution of the Board of Directors of The Hanover Insurance Company, Massachusetts Bay Insurance Company and Citizens Insurance Company of America.

"RESOLVED, That any and all Powers of Attorney and Certified Copies of such Powers of Attorney and certification in respect thereto, granted and executed by the President or any Vice President in conjunction with any Assistant Vice President of the Company, shall be binding on the Company to the same extent as if all signatures therein were manually affixed, even though one or more of any such signatures thereon may be facsimile." (Adopted October 7, 1981 - The Hanover Insurance Company; Adopted April 14, 1982 Massachusetts Bay Insurance Company; Adopted September 7, 2001 - Citizens Insurance Company of America)

GIVEN under my hand and the seals of said Companies, at Worcester, Massachusetts, this 13th day of July, 20 11

THE HANOVER INSURANCE COMPANY
MASSACHUSETTS BAY INSURANCE COMPANY
CITIZENS INSURANCE COMPANY OF AMERICA

Stephen L. Braut
Stephen L. Braut, Assistant Vice President

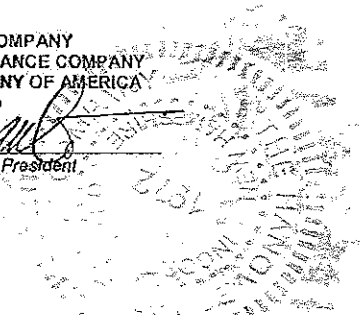

**LEGAL REQUIREMENTS AND RESPONSIBILITY TO THE PUBLIC – E-VERIFY.
(REV 1-19-11) (2-11)**

SECTION 7 (Pages 56 – 80) is expanded by the following new Article:

7-28 E-Verify.

The Contractor shall utilize the U.S. Department of Homeland Security's E-Verify system, in accordance with the terms governing use of the system, to confirm the employment eligibility of all persons employed by the Contractor during the term of the Contract to perform employment duties within Florida and all persons, including subcontractors, assigned by the Contractor to perform work pursuant to the Contract with the Department.

INTEROFFICE MEMORANDUM

To: Janet Muccino, Project Manager
CC: Sue Snider, Purchasing
From: Cheri Smith, City Clerk
Date: April 13, 2011
Subject: **COLLEGE ROAD ENHANCEMENTS; BID #11-014 - PROJECT GR 0711**

Attached for your review are copies of the bids opened Wednesday, April 13, 2011 at 3:30 p.m. in response to the above referenced project.

- | | | | |
|----|--|--------|--------------|
| 1. | D. N. Higgins, Inc.
3390 Travis Pointe Road, Suite A
Ann Arbor, MI 48108 | Total: | \$319,000.00 |
| 2. | Charlie Toppino & Sons, Inc.
P O Box 787
Key West, FL 33041 | Total: | \$260,207.31 |

CS/sph

Bid #11-014 Project GR 0711 College Road Enhancements

PROPOSAL

To: The City of Key West
Address: 525 Angela Street, P.O. Box 1409
Key West, Florida 33041
Project Title: **College Road Enhancements
Overseas Highway to Kokenzie Road**
Project No.: GN- 0711

Bidder's person to contact for additional information on this Proposal:

Name: Ronald J Armstrong
Telephone: 305 296 5606

BIDDER'S DECLARATION AND UNDERSTANDING

The undersigned, hereinafter called the Bidder, declares that the only persons or parties interested in this Proposal are those named herein, that this Proposal is, in all respects, fair and without fraud, that it is made without collusion with any official of the Owner, and that the Proposal is made without any connection or collusion with any person submitting another Proposal on this Contract.

The Bidder further declares that he has carefully examined the Contract Documents, that he has personally inspected the Project, that he has satisfied himself as to the quantities involved, including materials and equipment, and conditions of work involved, including the fact that the description of the quantities of work and materials, as included herein, is brief and is intended only to indicate the general nature of the work and to identify the said quantities with the detailed requirements of the Contract Documents, and that this Proposal is made according to the provisions and under the terms of the Contract Documents, which Documents are hereby made a part of this Proposal.

The Bidder further agrees that he has exercised his own judgment regarding the interpretation of subsurface information and has utilized all data which he believes pertinent from the Engineer, Owner, and other sources in arriving at his conclusions.

The Bidder further agrees, as evidenced by signing the Proposal, which if awarded a Contract, the Florida Trench Safety Act and applicable trench safety standards will be complied with.

The Bidder understands and agrees that if a Contract is awarded, the Owner may elect to award all schedules under one Contract, separately, or in any combination that best serves the interests of the Owner.

CONTRACT EXECUTION AND BONDS

The Bidder agrees that if this Proposal is accepted, he will, within 10 days, not including Sundays and legal holidays, after Notice of Award, sign the Contract in the form annexed hereto, and will at that time, deliver to the Owner examples of the Performance Bond and Payment Bond required herein, and evidence of holding required licenses and certificates, and will, to the extent of his Proposal, furnish all machinery, tools, apparatus, and other means of construction and do the work and furnish all the materials necessary to complete all work as specified or indicated in the Contract Documents.

CERTIFICATES OF INSURANCE

Bidder agrees to furnish the Owner, before commencing the work under this Contract, the certificates of insurance as specified in these Documents.

START OF CONSTRUCTION AND CONTRACT COMPLETION TIME

The Bidder further agrees to begin work within 14 calendar days of the Notice to Proceed (NTP) and to complete the construction in all respects within 120 calendar days from the date of the NTP.

LIQUIDATED DAMAGES

In the event the Bidder is awarded the Contract and fails to complete the work within the time limit or extended time limit agreed upon, as more particularly set forth in the Contract Documents, liquidated damages shall be paid to the Owner based on the current FDOT Standard Specifications Section 8-10 until the work has been satisfactorily completed as provided by the Contract Documents. Sundays and legal holidays shall be included in determining days in default. FDOT 8-10 Code requirements govern, and herewith made a part of the Contract.

Original Contract Amount	Daily Charge Per Calendar Day
\$50,000 and Under	\$313
Over \$50,000 but less than \$250,000	\$580
\$250,000 but less than \$500,000	\$715
\$500,000 but less than \$2,500,000	\$1,423
\$2,500,000 but less than \$5,000,000	\$2,121
\$5,000,000 but less than \$10,000,000	\$3,057

ADDENDA

The Bidder hereby acknowledges that he has received Addenda No's. 1, 1, , ,,
 (Bidder shall insert No. of each Addendum received) and agrees that all addenda issued are hereby made part of the Contract Documents, and the Bidder further agrees that his Proposal(s) includes all impacts resulting from said addenda.

SALES AND USE TAXES

The Bidder agrees that all federal, state, and local sales and use taxes are included in the stated bid prices for the work.

UNIT PRICE ITEMS

The Bidder further proposes to accept as full payment for the work proposed herein the amounts computed under the provisions of the Contract Documents and based on the following unit price amounts, it being expressly understood that the unit prices are independent of the exact quantities involved. The Bidder agrees that the unit prices represent a true measure of the labor and materials required to perform the work, including all allowances for overhead and profit for each type and unit of work called for in these Contract Documents. The amounts shall be shown in both words and figures. In case of a discrepancy, the amount shown in words shall govern. Unit price line items may be deleted, reduced or increased as needed within the awarded contract price by the city.

COLLEGE ROAD ENHANCEMENTS

BID SCHEDULE

The Bidder further Proposes to accept as full payment for the work Proposed herein the amounts computed under the Provisions of the Contract Documents and based on the following unit Price amounts, it being expressly understood that the unit Prices are independent of the exact quantities involved. The Bidder agrees that the unit Prices represent a true measure of the labor and materials required to perform the work, including all allowances for overhead and Profit for each type and unit of work called for in these Contract Documents. The amounts shall be shown in both words and figures. In case of a discrepancy, the amount shown in words shall govern. Unit price line items may be deleted, reduced or increased as needed within the awarded contract price by the city

<u>Item</u>	<u>Quant.</u>	<u>Unit</u>	<u>UP (Fig)</u>	<u>UP (Words)</u>	<u>Extended Total Amount</u>
1. Performance and Payment Bonds				Four Thousand Eight Hundred	
	1	LS	\$ 4,872.00	Seventy Two - 00/100	\$ 4,872.00
2.) Mobilization / Demobilization, FDOT Grant Requirements, General & Supplementary Conditions, MOT, Certified AutoCAD As-Builts)					
a.) Mobilization / Field Engineering / Testing / Environmental / Construction layout/ pre - construction video (paid 25%, then on percentage of completion)					
	1	LS	\$ 12,500.00	Twelve Thousand Five Hundred Dollars - 00/100	\$ 12,500.00
b.) Demobilization (paid at completion of final punch list completion)					
	1	LS	\$ 6,250.00	Six Thousand Two Hundred Fifty Dollars - 00/100	\$ 6,250.00
c.) FDOT Grant Requirements, General & Supplementary Conditions, (paid 25%, then on percentage of completion)					
	1	LS	\$ 17,625.00	Seventeen Thousand Six Hundred Twenty Five Dollars - 00/100	\$ 17,625.00
d.) MOT, (paid 25%, then on percentage of completion)					
	1	LS	\$ 26,700.00	Twenty Six Thousand Seven Hundred Dollars - 00/100	\$ 26,700.00
e.) Certified AutoCAD As-Builts / Surveyor (paid after submission and acceptance of as-builts)					
	1	LS	\$ 4,375.00	Four Thousand Three Hundred Seventy Five Dollars - 00/100	\$ 4,375.00

<u>Item</u>	<u>Quant.</u>	<u>Unit</u>	<u>UP (Fig)</u>	<u>UP (Words)</u>	<u>Extended Total Amount</u>
3). Clearing and Grubbing (to be paid for as described in the current FDOT Standards and Specifications, Section 110; includes cutting back grass growing over edge of pavement; includes tree/plant relocation or transplantation; includes pruning tree roots adjacent to roadway as required)	0.98	AC	\$ 11,352.04	Eleven Thousand Three Hundred Fifty Two Dollars — 04/100	11,125.00
4). Sidewalk Installation (material and labor to install; including excavation, backfill and compaction)					
a. 4" Depth (e.g. sidewalk throughout most of project)	974	SY	\$ 54.40	Fifty Four Dollars — 40/100	52,985.60
b. 6" Depth (e.g. sidewalk crossing driveways, 6' X 12' bus stop pads)	199	SY	\$ 76.99	Seventy Six Dollars — 99/100	15,321.01
c. Thickened Edge (sections of sidewalk / driveway without curbs and as directed)	3,362	LF	\$ 11.15	Eleven Dollars — 15/100	37,486.30
d. Bridged sidewalk over ditch bottom inlet (material and labor to install; including formwork required for 6" thick concrete)	5	CY	\$ 850.00	Eight Hundred Fifty Dollars — 00/100	4,250.00
5). Curb Installation (material and labor to install; including excavation, backfill and compaction)					
a. FDOT Type "F"	50	LF	\$ 43.75	Forty Three Dollars — 75/100	2,187.50
b. Flared end curb	1	EA	\$ 250.00	Two Hundred Fifty Dollars — 00/100	250.00
6). Guardrail (e.g. for section of sidewalk bridged over ditch bottom inlet)	35	LF	\$ 140.04	One Hundred Forty Dollars — 04/100	4,901.40
7). Asphalt/sp 9.5/1.5" (e.g. for incidental damage to sections of asphalt where sidewalk is formed close to edge of pavement and where 6" sidewalk crosses driveways)	50	SY	\$ 81.25	Eighty One Dollars — 25/100	4,062.50
8). Utility Adjustments (cost for complete installation, labor and materials)					
a. Adjust water valves / boxes (FKAA) vertically and/or laterally as required (complete cost for material and labor to adjust existing utility features as required)	3	EA	\$ 312.50	Three Hundred Twelve Dollars — 50/100	937.50

Item Quant. Unit UP (Fig) UP (Words) Extended Total Amount

9). Silt Fence (e.g. for use behind back of proposed sidewalk at wetland area, as shown on plans)

415 LF \$ 2.50 Two Dollars - 50/100 \$ 1,037.50

10). Plastic Delineators – flexible tubing (cost for complete installation, labor, and materials)

20 EA \$ 75.00 Seventy Five Dollars - 00/100 \$ 1,500.00

11). ADAAG Detectable Warning System (2-1/4 x 4 x 8 Endicott Red Brick Pavers (cost for complete installation, labor, and materials)

12 ~~SF~~ SF \$ 37.50 Thirty Seven Dollars - 50/100 \$ 450.00

12). Sodding (areas disturbed by construction activity -- replace with same material)

3200 SY \$ 5.63 Five Dollars - 63/100 \$ 18,016.00

13). Remove Existing Trees/Shrubs (0-10" Diameter). Includes all Labor, Materials, Equipment and Maintenance, and Disposal / including city permit requirements

4 EA \$ 250.00 Two Hundred Fifty Dollars - 00/100 \$ 1,000.00

14). Remove Existing Tree (over 10" Diameter) Includes all Labor, Materials, Equipment and Maintenance, and Disposal / including city permit requirements

2 EA \$ 625.00 Six Hundred Twenty Five Dollars - 00/100 \$ 1,250.00

15). Business Sign relocation (Includes all Labor, Materials, and Equipment to remove and replace existing signs as directed by engineer)

3 EA \$ 375.00 Three Hundred Seventy Five Dollars - 00/100 \$ 1,125.00

16). Allowance

LS \$ 30,000 Thirty thousand \$ 30,000

260,207.31

TOTAL OF ALL EXTENDED UNIT PRICE ITEMS LISTED ABOVE including allowance items

Two Hundred Sixty Thousand Two Hundred Seven Dollars Dollars and 31 Cents

(Amount Written in Words has Precedence)

ADD/ALTS 1-4

Add Alternates are not a part of the base bid and shall only be added to the contract at the owners discretion.

<u>Item</u>	<u>Quant.</u>	<u>Unit</u>	<u>UP (Fig)</u>	<u>UP (Words)</u>	<u>Extended Total Amount</u>
1). Seepage Trench				Eighty Seven	
	100	LF	\$ <u>87.75</u>	Dollars - 75/100	\$ <u>8,775.00</u>
2). Striping (White retro-reflective 6", as required)				Eight Thousand	
	0.6	NM	\$ <u>8,392.80</u>	Three Hundred	\$ <u>5,035.68</u>
3). Bus Shelters				Ninety Two	
	2	EA	\$ <u>8,728.13</u>	Dollars - 80/100	\$ <u>17,456.26</u>
4). Gravel Stone, 1/2 inch to 3/4 inch diameter (includes cost of material and labor to excavate 6" deep shoulder, grade bottom of shoulder, and backfill. Gravel will be for use in specified areas between edge of pavement and front of sidewalk as directed by the engineer).				Eight Thousand	
	65	TONS	\$ <u>89.60</u>	Seven Hundred Twenty Eight Dollars - 13/100	\$ <u>5,824.00</u>

\$ 37,090.94

TOTAL OF ADD/ALT UNIT PRICE ITEMS LISTED ABOVE

\$ Thirty Seven Thousand
Ninety Dollars Dollars and 94 Cents
 (Amount Written in Words has Precedence)

List items to be performed by Contractor's own forces and the estimated total cost of these items.
(Use additional sheets if necessary.)

All work except Asphalt.	95%

SUBCONTRACTORS

The Bidder further proposes that the following subcontracting firms or businesses will be awarded subcontracts for the following portions of the work in the event that the Bidder is awarded the Contract:
Note to Bidder: Subcontractors shall be prequalified to perform projects for FDOT.

Asphalt
Portion of Work
Bee Bras Development, Inc.
Name ste 258
8362 Pines Blvd Pembroke Pines, FL 33024
Street City State Zip

Portion of Work

Name

Street City State Zip

Portion of Work

Name

Street City State Zip

Portion of Work

Name

Street City State Zip

SURETY

The Hanover Insurance Co whose address is
440 Lincoln St, Worcester, MA, 01653
Street City State Zip

BIDDER

The name of the Bidder submitting this Proposal is

CHARLEY TOPPINO & SONS, INC. doing business at
P.O. Box 787 Key West, FL 33041
Street City State Zip

which is the address to which all communications concerned with this Proposal and with the Contract shall be sent.

The names of the principal officers of the corporation submitting this Proposal, or of the partnership, or of all persons interested in this Proposal as principals are as follows:

Name	Title
<u>Frank P. Toppino</u>	<u>President</u>
<u>Edward Toppino, Sr</u>	<u>Secretary / Treasurer</u>
<u>Daniel P. Toppino</u>	<u>Assistant Secretary</u>
_____	_____
_____	_____

If Sole Proprietor or Partnership

IN WITNESS hereto ~~to the undersigned~~ has set his (its) hand this _____ day of _____ 2011.

Signature of Bidder

Title

If Corporation

IN WITNESS WHEREOF the undersigned corporation has caused this instrument to be executed and its seal affixed by its duly authorized officers this 14 day of March 2011.

(SEAL)

CHARLEY TOPPINO & SONS, INC.

Name of Corporation

By Frank P. Jappone

Title President

Attest D. P. Jappone
Secretary

CHARLEY TOPPINO & SONS, INC.

P.O. BOX 787

KEY WEST, FL 33041

305 296-5606

PAST PROJECTS

Please note: Frank P. Toppino and Edward Toppino, Sr., president and Secretary/Treasurer for CHARLEY TOPPINO & SONS, INC. has been involved, supervised, estimated and overseen the following projects. Paul E. Toppino and Edward Toppino, Jr. have also estimated and been involved in many of the following projects. Mr. Frank P. Toppino and Mr. Edward Toppino have been in the construction business for over 60 years each. Toppino's Inc., incorporated for 21 years, had its name change to CHARLEY TOPPINO & SONS, INC. 5 years ago.

1) CITY OF KEY WEST
P.O. BOX 1409
KEY WEST, FL 33040
305 809-3965

SCOPE OF WORK: STORM DRAINAGE, INJECTIONS WELLS, SIDEWALKS, CURBS, FOUNDATIONS, PIER REPAIR, LANDSCAPING & MAINTENANCE, ROADWORK, ASPHALT.

PROJECTS:

RIGHT OF WAY MAINTENANCE: 1998-2009	\$2,352,000	BOND YES
CONCRETE PLACEMENT- 2002, 2005, 2007	\$2,400,000	BOND YES
WHITE STREET PIER REPAIR	\$ 88,000	BOND YES
STAPLES AVE BRIDGE	\$ 81,000	BOND YES
HOCKEY RINK	\$ 50,000	BOND YES
KAMIEN SUBDIVISION	\$1,656,000	BOND YES
SOUTHERNMOST POINT REHABILITATION	\$ 73,000	BOND YES
GENERAL SERVICES CON. 1998—2000	\$4,000,000	BOND YES
GENERAL SERVICES CON. 2002, 2005	\$2,000,000	BOND YES
GENERAL SERVICES CON. 2007	\$2,000,000	BOND YES
GENERAL SERVICES CON. 2011	\$1,000,000	BOND YES
GRAVITY INJECTION WELLS: PHASE I	\$4,800,000	BOND YES
GRAVITY INJECTION WELLS: PHASE II	\$2,236,000	BOND YES
GRAVITY INJECTION WELLS: PHASE 5	\$1,998,385	BOND YES
GRAVITY INJECTION WELLS: PHASE 6	\$1,989,225	BOND YES
JOSE MARTI VEG REMOVAL / DRAINAGE	\$ 90,000	BOND NO
SMATHERS BEACH LANDSCAPING	\$ 100,000	BOND YES
DONALD AVE DRAINAGE SWALE	\$ 61,000	BOND NO
HURRICANE GEORGES CLEANUP	\$ 431,000	BOND NO
MITIGATION FLOW PROJECT	\$2,100,000	BOND YES
HARBOR WALK KW BIGHT	\$3,040,000	BOND YES
DINGY DOCKS 2001	\$ 104,000	BOND YES
WHITE ST PIER RIP RAP	\$ 131,054	BOND YES
FLAGLER AVE PHASE 1 & 2	\$1,391,000	BOND YES
WHITE ST PUMP STATION	\$1,645,000	BOND YES
SIDEWALK ENHANCEMENTS: PHASE 1	\$ 218,890	BOND YES
SIDEWALK ENHANCEMENTS: PHASE 2	\$ 164,181	BOND YES

SIDEWALK ENHANCEMENTS: PHASE 3 \$ 253,666 BOND YES

2) MONROE COUNTY

1100 SIMONTON STREET
KEY WEST, FL 33040
305 292-4426

SCOPE OF WORK: SITE WORK, STORM DRAINAGE, INJECTIONS WELLS, SIDEWALKS, CURBS, LANDSCAPING, ROADWORK, ASPHALT, PLAYGROUNDS.

PROJECTS:

PALM AVE ROADWAY	\$ 931,000	BOND YES
WILHELMINA PARK	\$ 145,000	BOND YES
MARATHON AIRPORT TAXILANES, T HANGER DEV.	\$2,366,000	BOND YES
MARATHON AIRPORT SERVICE ROAD	\$ 688,000	BOND YES
KW INTN AIRPORT: EXOTIC VEGETATION REMOVE	\$ 192,000	BOND YES
KW INTN AIRPORT: PARKING LOTS	\$ 531,000	BOND YES
BIG COPPITT PARK	\$ 860,242	BOND YES
BIG PINE BASIN FILL IN AND DEMO	\$ 904,943	BOND YES
MARATHON AIRPORT APRONS	\$ 376,344	BOND YES
PRADO CIRCLE	\$ 339,000	BOND YES
PALM DR BRIDGE REPAIR	\$ 131,000	BOND NO

3) FLORIDA DEPT OF TRANSPORTATION

605 Suwannee Street
Tallahassee, FL 32399-0450
(850) 414-4000

SCOPE OF WORK: SITE WORK, DEMOLITION, STORM DRAINAGE, SANITARY SEWER, INJECTIONS WELLS, SIDEWALKS, CURBS, ROADWORK, ASPHALT, HURRICANE CLEANUP, RIP-RAP INSTALL,

TRUMAN AVE PROJECT:	\$10,500,000	BOND YES
BIG COPPITT BIKE PATH:	\$ 480,000	BOND YES
EMERGENCY ROAD REPAIRS, HURR WILMA:	\$ 185,000	BOND NO
HURRICANE GEORGES ROAD REPAIRS:	\$ 52,000	BOND NO
KNIGHTS KEY	\$ 373,000	BOND YES
BIG COPPITT BOAT RAMP & SPANISH HARBOR:	\$ 500,000	BOND NO
BIKE PATH SADDLE BUNCH KEYS	\$ 450,000	BOND YES
BOCA CHICA SEAGRASS MITIGATION	\$ 1,352,930	BOND YES

3) SAUER INC

11223 PHILLIPS PARKWAY DR EAST
JACKSONVILLE, FL 32256-15274
904 262-6444

SCOPE OF WORK: SITE WORK, DEMOLITION, STORM DRAINAGE, SANITARY SEWER, INJECTIONS WELLS, SIDEWALKS, CURBS, ROADWORK, ASPHALT.

PROJECTS:

CONTROL TOWER, BOCA CHICA NAS	\$832,000	BOND YES
WEATHER STATION, KEY WEST	\$366,000	BOND YES
NAVAL RESEARCH LAB	\$100,000	BOND NO
REPAIR MARINE OPS, COAST GUARD	\$337,000	BOND NO

4.) FLORIDA KEY AQUADUCT AUTHORITY
1100 KENNEDY DRIVE
KEY WEST, FL 33040
305 296-2454

SCOPE OF WORK: SITE WORK, STORM DRAINAGE, SIDEWALKS, CURBS, ROADWORK, ASPHALT, STEEL BUILDING, WATER MAINS, DEMOLITION.

PROJECTS:

FCAA CONSTRUCTION YARD BUILDING	\$ 682,000	BOND YES
PUMP STATION	\$ 377,555	BOND YES
BIG COPPITT WASTE WATER SYSTEM	\$11,078,347	BOND YES
DEMO WATER TANKS, BIG COPPITT	\$ 55,000	BOND YES
FLAGLER AVE WATERMAIN	\$ 306,861	BOND YES

5.) GULF BUILDERS
P.O. BOX 668307
POMPANO BEACH, FL 33066
954 583-5115

SCOPE OF WORK: SITE WORK, STORM DRAINAGE, SANITARY SEWER, WATER MAINS, INJECTIONS WELLS, SIDEWALKS, CURBS, ROADWORK, PARKING LOTS, ASPHALT.

PROJECTS:

ROOSEVELT GARDENS HOUSING PROJECT	\$1,256,000	BOND	YES
-----------------------------------	-------------	------	-----

6.) BJ&K CONSTRUCTION
970 WEST MCNAB ROAD
FORT LAUDERDALE, FL 33309
954 974-7744

SCOPE OF WORK: SITE WORK, DEMOLITION, STORM DRAINAGE, SANITARY SEWER, WATER MAINS, INJECTIONS WELLS, SIDEWALKS, CURBS, ROADWORK, PARKING LOTS, ASPHALT.

PROJECTS:

MERIDIAN WEST APARTMENTS

\$1,700,000

BOND

YES

7.) HEERY INTERNATIONAL

1625 DENNIS STREET
KEY WEST, FL 33040
305 293-3008

SCOPE OF WORK: SITE WORK, DEMOLITION, STORM DRAINAGE, SANITARY SEWER, WATER MAINS, INJECTIONS WELLS, GAS LINES, SIDEWALKS, CURBS, ROADWORK, PARKING LOTS, ASPHALT.

PROJECTS:

KEY WEST HIGH SCHOOL REPLACEMENT: PHASES 1, 2, 3 \$633,000 BOND YES
POINCIANA ELEMENTARY SCHOOL: \$2,240,000 BOND YES

8. COASTAL CONSTRUCTION

5959 BLUE LAGOON DR
STE 200
MIAMI, FL 33126
305 559-4900

SCOPE OF WORK: SITE WORK, DEMOLITION, FILL, CONCRETE FLATWORK, COLUMNS, RETAINING WALLS, CURBS, ROADWORK, PARKING LOTS, ASPHALT.

PROJECTS:

SUGARLOAF ELEMENTARY SCHOOL: \$2,300,000 BOND YES
BEACHSIDE CONDOS \$2,665,000 BOND YES
POINCIANA ROYALE \$ 524,520 BOND YES

9.) HISTORIC TOURS OF AMERICA

201 FRONT STREET
Key West, Florida 33040
305 296-3609

SCOPE OF WORK: SITE WORK, DEMOLITION, STORM DRAINAGE, SANITARY SEWER, WATER MAINS, INJECTIONS WELLS, GAS LINES, SIDEWALKS, CURBS, ROADWORK, PARKING LOTS, ASPHALT.

PROJECTS:

PARK VILLAGE \$ 317,000 BOND NO
MARQUESA COURT \$ 405,000 BOND NO
KEY COVE LANDINGS \$ 675,000 BOND NO

10.) DEMOYA GROUP
12209 S. DIXIE HWY
MIAMI, FL 33156
305 255-5713

SCOPE OF WORK: STORM DRAINAGE , INJECTIONS WELLS, ROAD BASE, CONCRETE WORK.

PROJECTS:

SOUTH ROOSEVELT BLVD. REHAB	\$1,507,000.00	BOND NO (SUB)
BIG COPPITT US 1 ROAD EXPANSION	\$ 2,157,000	BOND NO (SUB)

11.) DL PORTER
6574 PALMER CIRCLE
SARASOTA, FL 34238
941 929-9400

SCOPE OF WORK: SITE WORK, DEMOLITION, STORM DRAINAGE, SANITARY SEWER, WATER MAINS, INJECTIONS WELLS, GAS LINES, SIDEWALKS, CURBS, ROADWORK, PARKING LOTS, ASPHALT.

PROJECTS:

HOMELAND SECURITY, KEY WEST	\$ 231,600.00	BOND NO
KEY WEST INTERNATIONAL AIRPORT	\$ 724,000.00	BOND NO
SANTA MARIA HOTEL	\$ 225,000.00	BOND NO
COUCH HARBOR	\$ 210,000.00	BOND NO
ATLANTIC SHORES DEMO & SITEWORK	\$1,011,000.00	BOND NO
TRUMAN HOTEL SITEWORK	\$ 55,000.00	BOND NO

12.) HARRY PEPPER & ASSOCIATES
215 CENTURY 21 DRIVE
JACKSONVILLE, FL 32216
904 721-3300

SCOPE OF WORK: SITE WORK, DEMOLITION, STORM DRAINAGE, SANITARY SEWER, WATER MAINS, INJECTIONS WELLS, GAS LINES, SIDEWALKS, CURBS, ROADWORK, PARKING LOTS, ASPHALT.

PROJECTS:

REPAIR BASE OPERATIONS, BOCA CHICA	\$601,000	BOND NO
ELLISON DRIVE, TRUMBO POINT	\$ 116,000	BOND NO
BEQ, TRUMAN ANNEX	\$ 70,000	BOND NO
JIAFT EAST WAREHOUSE	\$462,000	BOND NO

13.) BRPH
3275 SUNTREE BLVD
MELBOURNE, FL 32940

SCOPE OF WORK: SITE WORK, DEMOLITION, STORM DRAINAGE, SANITARY SEWER, WATER MAINS, INJECTIONS WELLS, GAS LINES, SIDEWALKS, CURBS, ROADWORK, PARKING LOTS, ASPHALT.

PROJECTS:

ECO DISCOVERY CENTER	\$ 50,000	BOND NO
BOCA CHICA FITNESS CENTER	\$ 36,000	BOND NO
MARINA BY PASS ROAD, BOCA	\$348,000	BOND NO
TACTS BUILDING, BOCA CHICA	\$ 32,000	BOND NO
NANCY FOSTER ENVIRONMENTAL CTR	\$541,000	BOND NO
BLDG. # 324 PARKING	\$93,000	BOND NO

14. DOOLEY MACK CONTRACTORS
5800 LAKEWOOD RANCH BLVD.
SARASOTA, FL 34240
941 921-4636

SCOPE OF WORK: SITE WORK, DEMOLITION, STORM DRAINAGE, SANITARY SEWER, WATER MAINS, INJECTIONS WELLS, GAS LINES, SIDEWALKS, CURBS, ROADWORK, PARKING LOTS, ASPHALT.

STEAMPLANT CONDOS	\$1,332,000.00	BOND YES
THE MEADOWS, KEY WEST	\$ 145,000.00	BOND NO

15. BOTANICAL GARDENS
5210 COLLEGE ROAD
KEY WEST, FL 33040
305 296-1504

SCOPE OF WORK: DEMOLITION, , SIDEWALKS, CURBS, ROADWORK, PARKING LOTS, BOARDWALK / PILE CONSTRUCTION, BOULDER CUTTING & PLACEMENT, LAKE / POND CONSTRUCTION.

BOTANICAL GARDENS PHASE 1 POND	\$329,896.50	BOND YES
BOTANICAL GARDENS PHASE III	\$167,000.00	BOND YES

16. BALFOUR BEATTY MILITARY HOUSING MANAGEMENT LLC
10 CAMPUS BLVD.
NEWTOWN SQUARE, PA 19073
610 355-8051

SCOPE OF WORK: DEMOLITION, , SIDEWALKS, CURBS, ROADWORK, PARKING LOTS, BOARDWALK / PILE CONSTRUCTION, BOULDER CUTTING & PLACEMENT, LAKE / POND CONSTRUCTION.

RENOVATIONS FAMILY HOUSING MEDICAL CTR	\$141,350.00	BOND NO
RENOVATIONS TO QUARTERS LB, MEDICAL CTR	\$ 39,800.00	BOND NO

17. FL DEPT OF ENVIRONMENTAL PROTECTION
3900 COMMONWEALTH BLVD.
TALLAHASSEE, FL 32399-3000
305 420-8432

SCOPE OF WORK: BRIDGE REPAIR TO OLD OHIO BAHIA HONDA BRIDGE, MM 38.7, REPAIR ENTIRE SUPER STRUCTURE DECK, PROVIDE AND INSTALL AL PEDESTRIAN RAILING, MILL/RESURFACE AND STRIPE, SPALL / CRACK REPAIR.

OHIO BAHIA HONDA BRIDGE REPAIR: \$837,700.00 BOND YES

18. SH MARATHON, LTD.
506 FLEMING ST.
KEY WEST, FL 33040
305 294-6100

SCOPE OF WORK: DEMOLITION AND REBUILD OF HOTEL, RESTAURANT, MARINA AND BOAT SLIPS IN MARATHON, FL. HOLIDAY INN EXPRESS.

HOLIDAY INN EXPRESS: \$8,890,227 BOND YES

19. DORADO/CONQUISTADOR
541 N. PALMATTO AVE.
SUITE 104
SANFORD, FL 32771
407 688-0600

SCOPE OF WORK: SITEWORK, FILL REMOVAL AND PROCESSING AT THE BOCA CHICA NAVAL AIR STATION AIRFIELD.

BOCA CHICA AIRFIELD VEGETATION \$1,057,126.00 BOND YES

20. SS RAFFERTY, LLC
3717 EAGLE AVE
KEY WEST, FL 33040

SCOPE OF WORK: DEMOLITION, SITEWORK, BUILDING.

512 DUVAL STREET BUILDING \$1,071,586.28 BOND NO

WHEREAS, it was a condition precedent to the submission of said bid that a cashier's check, certified check, or bid bond in the amount of 5 percent of the base bid be submitted with said bid as a guarantee that the Bidder would, if awarded the Contract, enter into a written Contract with the Owner for the performance of said Contract, within 10 working days after written notice having been given of the award of the Contract.

NOW, THEREFORE, the conditions of this obligation are such that if the PRINCIPAL within 10 consecutive calendar days after written notice of such acceptance, enters into a written Contract with the OBLIGEE and furnishes the Performance and Payment Bonds, each in an amount equal to 100 percent of the base bid, satisfactory to the Owner, then this obligation shall be void; otherwise the sum herein stated shall be due and payable to the OBLIGEE and the Surety herein agrees to pay said sum immediately upon demand of the OBLIGEE in good and lawful money of the United States of America, as liquidated damages for failure thereof of said PRINCIPAL.

Signed and sealed this 3rd day of March, 2011.

PRINCIPAL Charley Toppino & Sons, Inc.

By Joseph P. Toppino

SURETY The Hanover Insurance Company,

By [Signature]

Attorney-In-Fact
William L. Parker, Attorney in Fact & FL Res Agent

THE HANOVER INSURANCE COMPANY
MASSACHUSETTS BAY INSURANCE COMPANY
CITIZENS INSURANCE COMPANY OF AMERICA

POWERS OF ATTORNEY
CERTIFIED COPY

KNOW ALL MEN BY THESE PRESENTS: That THE HANOVER INSURANCE COMPANY and MASSACHUSETTS BAY INSURANCE COMPANY, both being corporations organized and existing under the laws of the State of New Hampshire, and CITIZENS INSURANCE COMPANY OF AMERICA, a corporation organized and existing under the laws of the State of Michigan, do hereby constitute and appoint
Charles C. Ball, Heana M. Bauza, William F. Kleis, Davor I. Mimica and/or William L. Parker

of Miami, FL and each is a true and lawful Attorney(s)-in-fact to sign, execute, seal, acknowledge and deliver for, and on its behalf, and as its act and deed any place within the United States, or, if the following line be filled in, only within the area therein designated

any and all bonds, recognizances, undertakings, contracts of indemnity or other writings obligatory in the nature thereof, as follows:
Any such obligations in the United States, not to exceed Twenty Million and No/100 (\$20,000,000) in any single instance

and said companies hereby ratify and confirm all and whatsoever said Attorney(s)-in-fact may lawfully do in the premises by virtue of these presents. These appointments are made under and by authority of the following Resolution passed by the Board of Directors of said Companies which resolutions are still in effect:

"RESOLVED, That the President or any Vice President, in conjunction with any Assistant Vice President, be and they are hereby authorized and empowered to appoint Attorneys-in-fact of the Company, in its name and as its acts, to execute and acknowledge for and on its behalf as Surety any and all bonds, recognizances, contracts of indemnity, waivers of citation and all other writings obligatory in the nature thereof, with power to attach thereto the seal of the Company. Any such writings so executed by such Attorneys-in-fact shall be as binding upon the Company as if they had been duly executed and acknowledged by the regularly elected officers of the Company in their own proper persons." (Adopted October 7, 1981 - The Hanover Insurance Company; Adopted April 14, 1982 - Massachusetts Bay Insurance Company; Adopted September 7, 2001 - Citizens Insurance Company of America)

IN WITNESS WHEREOF, THE HANOVER INSURANCE COMPANY, MASSACHUSETTS BAY INSURANCE COMPANY and CITIZENS INSURANCE COMPANY OF AMERICA have caused these presents to be sealed with their respective corporate seals, duly attested by a Vice President and an Assistant Vice President, this 8th day of July 2009.



THE HANOVER INSURANCE COMPANY
MASSACHUSETTS BAY INSURANCE COMPANY
CITIZENS INSURANCE COMPANY OF AMERICA

Mary Jeanne Anderson, Vice President

Robert K. Grennan, Assistant Vice President

THE COMMONWEALTH OF MASSACHUSETTS)
COUNTY OF WORCESTER) ss.

On this 8th day of July 2009, before me came the above named Vice President and Assistant Vice President of The Hanover Insurance Company, Massachusetts Bay Insurance Company and Citizens Insurance Company of America, to me personally known to be the individuals and officers described herein, and acknowledged that the seals affixed to the preceding instrument are the corporate seals of The Hanover Insurance Company, Massachusetts Bay Insurance Company and Citizens Insurance Company of America, respectively, and that the said corporate seals and their signatures as officers were duly affixed and subscribed to said instrument by the authority and direction of said Corporations.

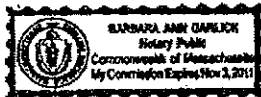

Notary Public

My commission expires on November 3, 2011

I, the undersigned Assistant Vice President of The Hanover Insurance Company, Massachusetts Bay Insurance Company and Citizens Insurance Company of America, hereby certify that the above and foregoing is a full, true and correct copy of the Original Power of Attorney issued by said Companies, and do hereby further certify that the said Powers of Attorney are still in force and effect.

This Certificate may be signed by facsimile under and by authority of the following resolution of the Board of Directors of The Hanover Insurance Company, Massachusetts Bay Insurance Company and Citizens Insurance Company of America.

"RESOLVED, That any and all Powers of Attorney and Certified Copies of such Powers of Attorney and certification in respect thereto, granted and executed by the President or any Vice President in conjunction with any Assistant Vice President of the Company, shall be binding on the Company to the same extent as if all signatures therein were manually affixed, even though one or more of any such signatures thereon may be facsimile." (Adopted October 7, 1981 - The Hanover Insurance Company; Adopted April 14, 1982 Massachusetts Bay Insurance Company; Adopted September 7, 2001 - Citizens Insurance Company of America)

GIVEN under my hand and the seals of said Companies, at Worcester, Massachusetts, this 3rd day of March, 2011

THE HANOVER INSURANCE COMPANY
MASSACHUSETTS BAY INSURANCE COMPANY
CITIZENS INSURANCE COMPANY OF AMERICA

Stephen L. Braut, Assistant Vice President

ANTI-KICKBACK AFFIDAVIT

STATE OF FLORIDA

SS:

COUNTY OF MONROE

THIS FORM MUST BE SIGNED AND SWORN TO IN THE PRESENCE OF A NOTARY PUBLIC OR OTHER OFFICIAL AUTHORIZED TO ADMINISTER OATHS.

This sworn statement is submitted to the City of Key West, Florida, by
Frank P. Toppino President (print individual's name and title)
for CHARLEY TOPPINO & SONS, INC.
(print name of entity submitting sworn statement)

whose business address is P.O. Box 287, Key West, FL 33041
and (if applicable) its Federal Employer Identification Number (FEIN) is

592426906 (if the entity has no FEIN, include the Social Security Number of the individual signing this sworn statement):

I, the undersigned, being hereby duly sworn, depose and say that no sum has been paid and no sum will be paid to any employee or elected official of the City of Key West as a commission, kickback, reward or gift, directly or indirectly, by me or any member of my firm, or by any officer or agent of the corporation.

BY: Frank P. Toppino
TITLE: President

sworn and prescribed before me this 14 day of 3, 2011

Ronald J. Armstrong
NOTARY PUBLIC, State of Florida

My commission expires:

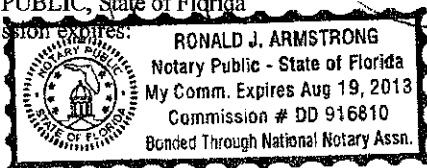

PUBLIC ENTITY CRIMES CERTIFICATION

THIS FORM MUST BE SIGNED AND SWORN TO IN THE PRESENCE OF A NOTARY PUBLIC OR OTHER OFFICIAL AUTHORIZED TO ADMINISTER OATHS,

1. This sworn statement is submitted to the City of Key West, Florida, by Frank P. Toppino President (print individual's name and title) for CHARLEY TOPPINO & SONS, INC. (print name of entity submitting sworn statement) whose business address is P.O. Box 7907 Key West, FL 33041 and (if applicable) its Federal Employer Identification Number (FEIN) is 592426906 (If the entity has no FEIN, include the Social Security Number of the individual signing this sworn statement _____):

2. I understand that a "public entity crime" as defined in Paragraph 287.133(1)(g), Florida Statutes, means a violation of any state or federal law by a person with respect to and _____ directly related to the transaction of business with any public entity or with an agency or political subdivision of any other state or of the United States, including, but not limited to, any bid or contract for goods or services to be provided to any public entity or an agency or political subdivision of any other state or of the United States and involving antitrust, fraud, theft, bribery, collusion, racketeering, conspiracy, or material misrepresentation.
3. I understand that "conviction" as defined in Paragraph 287.133(1)(g), Florida Statutes, means a finding of guilt or a conviction of a public entity crime, with or without an adjudication of guilt, in any federal or state trial court of record relating to charges brought by indictment or information after July 1, 1989, as a result of a jury verdict, nonjury trial, or entry of a plea of guilty or nolo contendere.
4. I understand that an "affiliate" as defined in Paragraph 287.133(1)(a), Florida Statutes, means:
1. A predecessor or successor of a person convicted of a public entity crime; or
 2. An entity under the control of any natural person who is active in the management of the entity and who has been convicted of a public entity crime. The term "affiliate" includes those officers, directors, executives, partners, shareholders, employees, members and agents who are active in the management of an affiliate. The ownership by one person of shares constituting a controlling interest in another person, _____ or a pooling of equipment of income among persons when not for fair market value under an arm's length agreement, shall be a prima facie case that one person controls another person. A person who knowingly enters into a joint venture with a person who has been convicted of a public entity crime in Florida during the preceding 36 months shall be considered an affiliate.
5. I understand that a "person" as defined in Paragraph 287.133(1)(e), Florida Statutes, means any natural person or entity organized under the laws of any state or of the United States with the legal power to enter into a binding contract and which bids or applies to bid on contracts for the provision of goods or services let by a public entity, or which otherwise transacts or applies to transact business with a public entity. The term "person" includes those officers, directors, executives, partners, shareholders, employees, members, and agents who are active in management of an entity.
6. Based on information and belief, the statement which I have marked below is true in relation to the entity submitting this sworn statement (indicate which statement applies).

Neither the entity submitting this sworn statement, or any of its officers, directors, executives, partners, shareholders, employees, members, or agents who are active in the management of the entity, nor any affiliate of the entity has been charged with and convicted of a public entity crime subsequent to July 1, 1989.

___ The entity submitting this sworn statement, or one or more of its officers, directors, executives, partners, shareholders, employees, members, or agents who are active in the management of the entity, or an affiliate of the entity has been charged with and convicted of a public entity crime subsequent to July 1, 1989.

___ The entity submitting this sworn statement, or one or more of its officers, directors, executives, partners, shareholders, employees, members, or agents who are active in the management of the entity, or an affiliate of the entity has been charged with and convicted of a public entity crime subsequent to July 1, 1989. However, there has been a subsequent proceeding before an Administrative Law Judge of the State of Florida, Division of Administrative Hearings and the Final Order entered by the Administrative Law Judge determined that it was not in the public interest to place the entity submitting this sworn statement on the convicted vendor list. (attach a copy of the final order)

I UNDERSTAND THAT THE SUBMISSION OF THIS FORM TO THE CONTRACTING OFFICER FOR THE PUBLIC ENTITY IDENTIFIED IN PARAGRAPH ONE (1) ABOVE IS FOR THAT PUBLIC ENTITY ONLY AND, THAT THIS FORM IS VALID THROUGH DECEMBER 31 OF THE CALENDAR YEAR IN WHICH IT IS FILED. I ALSO UNDERSTAND THAT I AM REQUIRED TO INFORM THE PUBLIC ENTITY PRIOR TO ENTERING INTO A CONTRACT IN EXCESS OF THE THRESHOLD AMOUNT PROVIDED IN SECTION 287.017, FLORIDA STATUTES, FOR CATEGORY TWO OF ANY CHANGE IN THE INFORMATION CONTAINED IN THIS FORM.

Frank P. Toppino (SIGNATURE)
3/14/11
(DATE)

STATE OF FL
COUNTY OF Monroe

PERSONALLY APPEARED BEFORE ME, the undersigned authority Frank P. Toppino who, after first being sworn by me, Frank P. Toppino (name of individual) affixed his/her signature in the space provided above on this 14 day of March, 2011.

Ronald J. Armstrong
NOTARY PUBLIC
RONALD J. ARMSTRONG
Notary Public - State of Florida
My Comm. Expires Aug 19, 2013
Commission # DD 916810
Bonded Through National Notary Assn.

My commission expires:

SUSPENSION AND DEBARMENT CERTIFICATION

CERTIFICATION REGARDING DEBARMENTS, SUSPENSION, INELIGIBILITY AND VOLUNTARY EXCLUSION-LOWER TIER FEDERALLY FUNDED TRANSACTIONS

- 1. The undersigned hereby certifies that neither it nor its principals is presently debarred, suspended, proposed for debarment, declared ineligible, or voluntarily excluded from participation in this transaction by any Federal department or agency.
- 2. The undersigned also certifies that it and its principals:
 - (a) Have not within a three-year period preceding this certification been convicted of or had a civil judgment rendered against them for commission of fraud or a criminal offense in connection with obtaining, attempting to obtain, or performing a public (Federal, State or local) transaction or contract under a public transaction; violation of Federal or State anti-trust statutes or commission of embezzlement, theft, forgery, bribery, falsification or destruction of records, making false statements, or receiving stolen property.
 - (b) Are not presently indicted for or otherwise criminally or civilly charged by a governmental entity (Federal, State or local) with commission of any of the offenses enumerated in paragraph 2.(a) of this Certification; and
 - (c) Have not within a three-year period preceding this certification had one or more public transactions (Federal, State or local) terminated for cause or default.
- 3. Where the undersigned is unable to certify to any of the statements in this certification, an explanation shall be attached to this certification.

Dated this 14 day of March, 2011.

By Frank P. Tappino
Authorized Signature/Contractor

Frank P. Tappino President
Typed Name/Title

CHARLEY TOPPINO & SONS, INC.

Contractor's Firm Name

P.O. Box 787 Key West, FL 33041
Street Address

Building, Suite Number

Key West FL 33041
City/State/Zip Code

305 296 5606
Area Code/Telephone Number

authorized by title 31 U.S.C. section 1352. This disclosure of lobbying activities is a material representation of fact upon which reliance was placed by the tier above when this transaction was made or entered into. This disclosure is required pursuant to 31 U.S.C. 1352. This information will be reported to Congress semi-annually and will be available for public inspection. Any person who fails to file the required disclosure shall be subject to a civil penalty of not less than \$10,000 and not more than \$100,000 for each such failure.

Print Name: Frank P. Toppino

Frank P. Toppino

Title: President

Telephone No.: 305 296 5606

Date: 3/14/11

Federal Use Only:

Authorized for Local Reproduction
Standard Form - LLL (Rev 7-97)

Form DEP 55-221 (01/01)

INSTRUCTIONS FOR COMPLETION OF SELF DISCLOSURE OF LOBBYING ACTIVITIES

This disclosure form shall be completed by the reporting entity, whether subawardee or prime Federal recipient, at the initiation or receipt of a covered Federal action, or a material change to a previous filing, pursuant to title 31 U.S.C. section 1352. The filing of a form is required for each payment or agreement to make payment to any lobbying entity for influencing or attempting to influence an officer or employee of any agency, a Member of Congress, an officer or employee of Congress, or an employee of a Member of Congress in connection with a covered Federal action. Complete all items that apply for both the initial filing and material change report. Refer to the implementing guidance published by the Office of Management and Budget for additional information.

1. Identify the type of covered Federal action for which lobbying activity is and/or has been secured to influence the outcome of a covered Federal action.
2. Identify the status of the covered Federal action.
3. Identify the appropriate classification of this report. If this is a follow up report caused by a material change to the information previously reported, enter the year and quarter in which the change occurred. Enter the date of the last previously submitted report by the reporting entity for this covered Federal action.
4. Enter the full name, address, city, state and zip code of the reporting entity. Include Congressional District, if known. Check the appropriate classification of the reporting entity that designates if it is or expects to be, a prime or subaward recipient. Identify the tier of the subawardee, e.g., the first subawardee of the prime is the 1st tier. Subawards include but are not limited to subcontracts, subgrants and contract awards under grants.
5. If the organization filing the report in item 4 checks "Subawardee", then enter the full name, address, city, state and zip code of the prime Federal recipient. Include Congressional District, if known.
6. Enter the name of the Federal agency making the award or loan commitment. Include at least one organizational level below agency name, if known. For example, Department of Transportation, United States Coast Guard.
7. Enter the Federal program name or description for the covered Federal action (item 1). If known, enter the full Catalog of Federal Domestic Assistance (CFDA) number for grants, cooperative agreements, loans, and loan commitments.
8. Enter the most appropriate Federal identifying number available for the Federal action identified in item 1 (e.g., Request for Proposal (RFP) number; Invitation for Bid (IFB) number; grant announcement number; the contract, grant, or loan award number; the application/proposal control number assigned by the Federal agency). Include prefixes, e.g., "RFP-DE-90-001."
9. For a covered Federal action where there has been an award or loan commitment by the Federal agency, enter the Federal amount of the award/loan commitment for the prime entity identified in item 4 or 5.
10. (a) Enter the full name, address, city, state and zip code of the lobbying entity engaged by the reporting entity identified in item 4 to influence the covered Federal action.

(b) Enter the full names of the individual(s) performing services, and include full address if different from 10 (a). Enter Last Name, First Name, and Middle Initial (MI).
11. The certifying official shall sign and date the form, print his/her name, title and telephone number.

According to the Paperwork Reduction Act, as amended, no persons are required to respond to a collection of information unless it displays a valid OMB Control Number. The valid OMB control number for this information collection is OMB No. 0348-0046. Public reporting burden for this collection of information is estimated to average 30 minutes per response, including time for reviewing instructions, searching existing data sources, gathering and maintaining the data needed, and completing and reviewing the collection of information. Send comments regarding the burden estimate or any other aspect of this collection of information, including suggestions for reducing this burden, to the Office of Management and Budget, Paperwork Reduction Project (0348-0046), Washington, D.C. 20503.

Form DEP 55-221 (01/01)

**NON-COLLUSION DECLARATION AND
COMPLIANCE WITH 49 CFR §29.**
STATE OF FLORIDA DEPARTMENT OF TRANSPORTATION

ITEM/SEGMENT NO.: _____
F.A.P. NO.: 421 379-1
PARCEL NO.: _____
COUNTY OF: Monroe
BID LETTING OF: March 24, 2011

I, Frank P. Toppino, hereby
declare that I am President (NAME) of CHARLEY TOPPINO & SONS, INC.
Of Key West, FL (CITY AND STATE) (FIRM)

and that I am the person responsible within my firm for the final decision as to the price(s) and amount of this Bid on this State Project.

I further declare that:

1. The prices(s) and amount of this bid have been arrived at independently, without consultation, communication or agreement, for the purpose of restricting competition with any other contractor, bidder or potential bidder.

2. Neither the price(s) nor the amount of this bid have been disclosed to any other firm or person who is a bidder or potential bidder on this project, and will not be so disclosed prior to the bid opening.

3. No attempt has been made or will be made to solicit, cause or induce any other firm or person to refrain from bidding on this project, or to submit a bid higher than the bid of this firm, or any intentionally high or non-competitive bid or other form of complementary bid.

4. The bid of my firm is made in good faith and not pursuant to any agreement or discussion with, or inducement from, any firm or person to submit a complementary bid.

5. My firm has not offered or entered into a subcontract or agreement regarding the purchase of materials or services from any firm or person, or offered, promised or paid cash or anything of value to any firm or person, whether in connection with this or any other project, in consideration for an agreement or promise by any firm or person to refrain from bidding or to submit a complementary bid on this project.

6. My firm has not accepted or been promised any subcontract or agreement regarding the sale of materials or services to any firm or person, and has not been promised or paid cash or anything of value by any firm or person, whether in connection with this or any other project, in consideration for my firm's submitting a complementary bid, or agreeing to do so, on this project.

7. I have made a diligent inquiry of all members, officers, employees, and agents of my firm with responsibilities relating to the preparation, approval or submission of my firm's bid on this project and have been advised by each of them that he or she has not participated in any communication, consultation, discussion, agreement, collusion, act or other conduct inconsistent with any of the statements and representations made in this Declaration.

8. As required by Section 337.165, Florida Statutes, the firm has fully informed the Department of Transportation in writing of all convictions of the firm, its affiliates (as defined in Section 337.165(1)(a), Florida Statutes), and all directors, officers, and employees of the firm and its affiliates for violation of state or federal antitrust laws with respect to a public contract or for violation of any state or federal law involving fraud, bribery, collusion, conspiracy or material misrepresentation with respect to a public contract. This includes disclosure of the names of current employees of the firm or affiliates who were convicted of contract crimes while in the employ of another company.

9. I certify that, except as noted below, neither my firm nor any person associated therewith in the capacity of owner, partner, director, officer, principal, investigator, project director, manager, auditor, and/or position involving the administration of Federal funds:

(a) is presently debarred, suspended, proposed for debarment, declared ineligible, or voluntarily excluded from covered transactions, as defined in 49 CFR §29.110(a), by any Federal department or agency;

(b) has within a three-year period preceding this certification been convicted of or had a civil judgment rendered against him or her for: commission of fraud or a criminal offense in connection with obtaining, attempting to obtain, or performing a Federal, State or local government transaction or public contract; violation of Federal or State antitrust statutes; or commission of embezzlement, theft, forgery, bribery, falsification or destruction of records, making false statements or receiving stolen property;

(c) is presently indicted for or otherwise criminally or civilly charged by a Federal, State or local governmental entity with commission of any of the offenses enumerated in paragraph 9(b) of this certification; and

(d) has within a three-year period preceding this certification had one or more Federal, State or local government public transactions terminated for cause or default..

10. I(We), certify that I(We), shall not knowingly enter into any transaction with any subcontractor, material supplier, or vendor who is debarred, suspended, declared ineligible, or voluntarily excluded from participation in this contract by any Federal Agency unless authorized by the Department.

Where I am unable to declare or certify as to any of the statements contained in the above stated paragraphs numbered (1) through (10), I have provided an explanation in the "Exceptions" portion below or by attached separate sheet.

EXCEPTIONS:

(Any exception listed above will not necessarily result in denial of award, but will be considered in determining bidder responsibility. For any exception noted, indicate to whom it applies, initiating agency and dates of agency action.

Providing false information may result in criminal prosecution and/or administrative sanctions.)

I declare under penalty of perjury that the foregoing is true and correct.

CONTRACTOR: (Seal)

BY: Frank P. Toppino President WITNESS: Ronald J Armstrong
NAME AND TITLE PRINTED
BY: Frank P. Toppino WITNESS: Ronald J Armstrong
SIGNATURE

Executed on this 14 day of March, 2011

**FAILURE TO FULLY COMPLETE AND EXECUTE THIS DOCUMENT
MAY RESULT IN THE BID BEING DECLARED NONRESPONSIVE**

CITY OF KEY WEST INDEMNIFICATION FORM

The Contractor shall indemnify and hold harmless the City of Key West, its officers, and employees, from liabilities, damages, losses and costs, including, but not limited to reasonable attorney's fees, to the extent caused by the negligence, recklessness or intentional wrongful misconduct of Contractor and persons employed or utilized by Contractor in the performance of this agreement. Except as specifically provided herein, this agreement does not require Contractor to indemnify the City of Key West, its employees, officers, directors, or agents from any liability, damage, loss, claim, action or proceeding.

These indemnifications shall survive the term of this agreement. In the event that any action or proceeding is brought against the City of Key West by reason of such claim or demand, Contractor shall, upon written notice from the City of Key West, resist and defend such action or proceeding by counsel satisfactory to the City of Key West.

The indemnification provided above shall obligate Contractor to defend at its own expense to and through appellate, supplemental or bankruptcy proceeding, or to provide for such defense, at the City of Key West's option, any and all claims of liability and all suits and actions of every name and description covered above which may be brought against the City of Key West whether performed by Contractor, or persons employed or utilized by Contractor.

The Contractor's obligation under this provision shall not be limited in any way by the agreed upon Contract Price as shown in this agreement, or the Contractor's limit of or lack of sufficient insurance protection.

CONTRACTOR: **CHARLEY TOPPINO & SONS, INC.**
Frank P. Toppino SEAL:
P.O. Box 787 Key West, FL 33041
Address

Signature
Frank P. Toppino
Print Name
President
Title
DATE: 3/14/11

BIDDER'S CHECKLIST

(Note: The purpose of this checklist is to serve as a reminder of major items to be addressed in submitting a bid and is not intended to be all inclusive. It does not alleviate the Bidder from the responsibility of becoming familiar with all aspects of the Contract Documents and Proper completion and submission of his bid.)

1. All Contract Documents thoroughly read and understood
2. All blank spaces in Proposal filled in, using black ink.
3. Total and unit Prices added correctly.
4. Addenda acknowledged.
5. Subcontractors are named as indicated in the Proposal.
6. Experience record included.
7. Proposal signed by authorized officer.
8. Bid Bond completed and executed, including power-of-attorney dated the same date as Bid Bond.
9. Bidder familiar with federal, state, and local laws, ordinances, rules and regulations affecting performance of the work.
10. Bidder shall demonstrate possession of required licenses and certificates to bid the job.
11. Proposal submitted intact with the volume entitled "Proposal" and Contract Forms, submit 1 original & 2 copies and 2 CD-Roms or flash drives each with one PDF file of the full Proposal.
12. Bid Documents submitted in sealed envelope and addressed and labeled in conformance with the instructions in the Invitation to Bid.
13. Bidder submitted FDOT Pre-certification paperwork
14. Bidder signed and submitted the suspension and debarment certification
15. Bidder signed and submitted Non-Collusion Declaration and Compliance with 49 CFR §29 form
16. Bidder signed and submitted the Prohibited Interests Form
17. Remainder of required forms.

STATEMENT OF NO PROPOSAL

Note: If you do not intend to submit a Proposal, please return this form ONLY.

TO: "College Road Enhancements, Overseas Highway to Kokenzie Road" GN 0711
Office of the City Clerk
City of Key West P.O. Box 1409
Key West, FL. 33041-1409

We, the undersigned, have declined to submit a Proposal on the above-noted Request for Proposal for the following reasons:

- Insufficient time to respond to the Request for Proposal
- Do not offer this Product
- Our schedule will not permit us to perform
- Unable to meet specifications
- Specifications unclear (Please explain below)
- Remove us from the City of Key West's, "Bidder's Mailing List"
- Other (Please specify below)

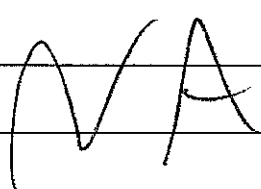
REMARKS: _____
_____ 

We understand that if a "no Proposal" statement is not returned, our name may be removed from the bidder's list of the City of Key West.

COMPANY NAME: _____

SIGNATURE: _____

DATE: _____ TELEPHONE: _____

AG/ 4482291

STATE OF FLORIDA

DEPARTMENT OF BUSINESS AND PROFESSIONAL REGULATION
CONSTRUCTION INDUSTRY LICENSING BOARD

SEQ# 009072100719

DATE	BATCH NUMBER	LICENSE NBR
07/23/2009	090047121	QB54715

The BUSINESS ORGANIZATION
Named below IS QUALIFIED
Under the provisions of Chapter 499 FS
Expiration date: AUG 31, 2011
(THIS IS NOT A LICENSE TO PERFORM WORK. THIS ALLOWS THE
COMPANY TO DO BUSINESS ONLY IF IT HAS A QUALIFIER.)
CHARLEY ROBBINO, SONS INC
PO BOX 787
KEY WEST FL 33040



CHARLES CRESS
GOVERNOR

CHARLES W. DRAGO
SECRETARY

DISPLAY AS REQUIRED BY LAW

AG/ 4482179

STATE OF FLORIDA

DEPARTMENT OF BUSINESS AND PROFESSIONAL REGULATION
CONSTRUCTION INDUSTRY LICENSING BOARD

SEQ# 00907230060

DATE	BATCH NUMBER	LICENSE NBR
07/23/2009	090047095	RG0045369

The GENERAL CONTRACTOR
Named below HAS REGISTERED
Under the provisions of Chapter 499 FS
Expiration date: AUG 31, 2011
(INDIVIDUAL MUST MEET ALL LOCAL LICENSING
REQUIREMENTS PRIOR TO CONTRACTING IN ANY
TOPPING FRANK E
CHARLEY TOPPING SONS INC
POST OFFICE BOX 787
KEY WEST FL 33041-0787

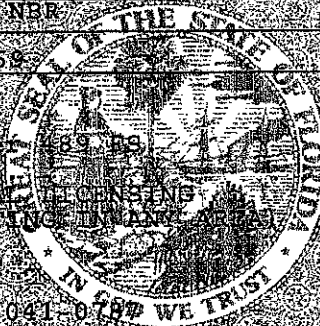

CHARLES CRESS
GOVERNOR

CHARLES W. DRAGO
SECRETARY

DISPLAY AS REQUIRED BY LAW

CITY OF KEY WEST
CERTIFICATE OF COMPETENCY

121 THIS IS TO CERTIFY THAT

Frank Toppino

is duly registered as a

General Contractor

in conformity with the regulations of the City of Key West

Date Issued: 10/01/09 Exp. Date: 09/30/11

By: John P. Wood
CHIEF BUILDING OFFICIAL

CITY OF KEY WEST
CERTIFICATE OF COMPETENCY

3064 THIS IS TO CERTIFY THAT

Frank Toppino

is duly registered as a

Engineering Contractor

in conformity with the regulations of the City of Key West

Date Issued: 10/01/09 Exp. Date: 09/30/11

By: John P. Wood
CHIEF BUILDING OFFICIAL

CITY OF KEY WEST, FLORIDA

Business Tax Receipt

This Document is a business tax receipt
 Holder must meet all City zoning and use provisions.
 P.O. Box 1409, Key West, Florida 33040 (305) 809-3955

Business Name CHARLEY TOPPINO & SONS (EDWAR) CtINbr:0005358
 Location Addr MM 8 1/2 ROCKLAND KEY
 Lic NBR/Class 11-00047557 CONTRACTOR REG ENGINEERING I
 Issue Date: September 10, 2010 Expiration Date: September 30, 2011
 License Fee \$309.75
 Add. Charges \$0.00
 Penalty \$0.00
 Total \$309.75
 Comments:

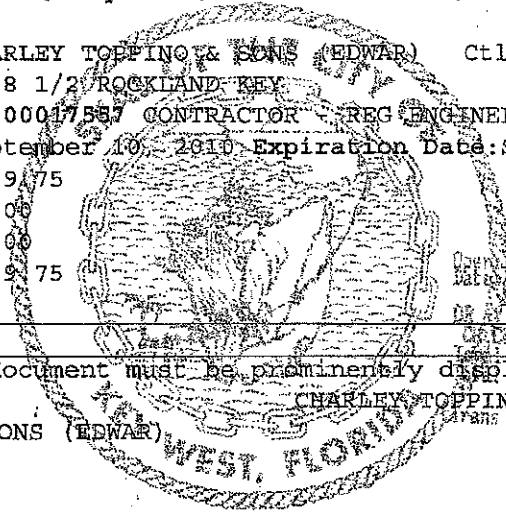

Created: CHARLEY
 Date: 9/10/10 5:11 PM Type: CC Drawn: 1
 Receipt #: 1103775
 DE BY: 1103775
 CHECK 51552 1309.75
 1309.75
 1309.75
 1309.75

This document must be prominently displayed.

CHARLEY TOPPINO & SONS, INC.

CHARLEY TOPPINO & SONS (EDWAR)
 EDWARD TOPPINO
 P.O. BOX 787
 KEY WEST FL 33041

Trans Date: 9/13/10 Time: 13:56:24

CITY OF KEY WEST, FLORIDA

Business Tax Receipt

This Document is a business tax receipt
Holder must meet all City zoning and use provisions.
P.O. Box 1409, Key West, Florida 33040 (305) 809-3955

Business Name CHARLEY TOPPINO & S (FRANK ENG CtlNbr:0010428
Location Addr 2011 FLAGLER AVE
Lic NBR/Class 11-00023996 CONTRACTOR - REG ENGINEERING I
Issue Date: September 15, 2010 Expiration Date: September 30, 2011
License Fee \$309.75
Add. Charges \$0.00
Penalty \$0.00
Total \$309.75
Comments:

This document must be prominently displayed.

CHARLEY TOPPINO & SONS, INC.

CHARLEY TOPPINO & S (FRANK ENG
FRANK TOPPINO
P.O. BOX 787
KEY WEST FL 33041

Dept: CHALKER
Date: 9/16/10 SS
0011 LID 23996
Lic 00023996
Trans number: 1
CK CHECK 51550
Type: CC
Receipt no: 111246
Drawn: 1
\$309.75
\$309.75
\$309.75

Trans date: 9/16/10
Time: 12:41:23

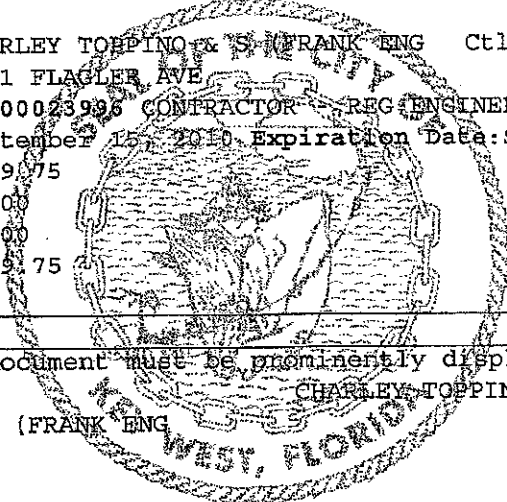

CITY OF KEY WEST, FLORIDA

Business Tax Receipt

This Document is a business tax receipt
 Holder must meet all City zoning and use provisions.
 P.O. Box 1409, Key West, Florida 33040 (305) 809-3955

Business Name	CHARLEY TOPPINO & S (FRANK RG)	CtlNbr:0005344
Location Addr	2011 FLAGLER AVE	
Lic NBR/Class	11-00023997 CONTRACTOR - REG GENERAL	
Issue Date:	September 15, 2010	Expiration Date: September 30, 2011
License Fee	\$309.75	
Add. Charges	\$0.00	
Penalty	\$0.00	
Total	\$309.75	
Comments:		

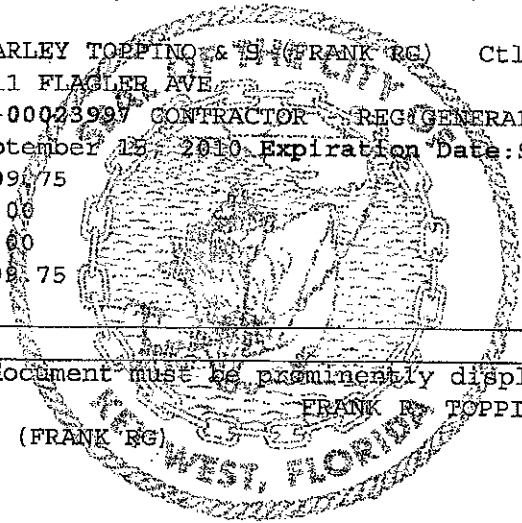

This document must be prominently displayed.

FRANK R. TOPPINO

CHARLEY TOPPINO & S (FRANK RG)
 POB 787

KEY WEST FL 33041

Dept: 000000
 Date: 9/15/10 22:39:57
 Lic: 11-00023997
 License Fee: \$309.75
 Add. Charges: \$0.00
 Penalty: \$0.00
 Total: \$309.75
 License Nbr: 11-00023997
 License Class: CONTRACTOR - REG GENERAL
 License Status: ACTIVE
 License Expiration: 9/30/2011
 License Fee: \$309.75
 License Fee Paid: \$309.75
 License Fee Due: \$0.00
 License Fee Paid Date: 9/15/2010
 License Fee Due Date: 9/30/2011
 License Fee Paid By: FRANK R. TOPPINO
 License Fee Due By: FRANK R. TOPPINO
 License Fee Paid From: 11-00023997
 License Fee Due From: 11-00023997
 License Fee Paid To: 11-00023997
 License Fee Due To: 11-00023997
 License Fee Paid By: FRANK R. TOPPINO
 License Fee Due By: FRANK R. TOPPINO
 License Fee Paid From: 11-00023997
 License Fee Due From: 11-00023997
 License Fee Paid To: 11-00023997
 License Fee Due To: 11-00023997

**2010 / 2011
MONROE COUNTY BUSINESS TAX RECEIPT
EXPIRES SEPTEMBER 30, 2011**

RECEIPT# 30140-89799

Business Name: CHARLEY TOPPINO & SONS

Owner Name: FRANK TOPPINO
 Mailing Address: BOX 787
 KEY WEST, FL 33040
 Business Location: MM 8-9 US HWY 1
 Business: CONTRACTORS (GEN CONT/ENGINEERING)

Rooms Seats Employees Machines Stalls

	Number of Machines	Penalty	Collection Cost	Total Paid
Tax Amount	Transfer Fee	Penalty	Collection Cost	Total Paid
250.00	0.00	0.00	0.00	250.00

Paid 122-09-00006408 02/08/2010 250.00

THIS RECEIPT MUST BE POSTED CONSPICUOUSLY IN YOUR PLACE OF BUSINESS

THIS BECOMES A TAX RECEIPT
WHEN VALIDATED

Danise D. Henriquez, CFC, Tax Collector
PO Box 1129, Key West, FL 33041

THIS IS ONLY A TAX.
YOU MUST MEET ALL
COUNTY AND/OR
MUNICIPALITY PLANNING
AND ZONING REQUIREMENTS.

**2010 / 2011
MONROE COUNTY BUSINESS TAX RECEIPT
EXPIRES SEPTEMBER 30, 2011**

RECEIPT# 30140-9142

Business Name: TOPPINO FRANK P

Owner Name: FRANK P TOPPINO
Mailing Address: PO BOX 787
KEY WEST, FL 33040

Business Location: US HWY 1
Business Phone: 305-296-5606
Business Description: CONTRACTORS (GENERAL/ENGINEERING CONTRACTOR)

Rooms Seats Employees Machines Stalls

	Number of Machines	Transfer Fee	Penalty	Prior Year	Collection Cost	Total Paid
Tax Amount		0.00	125.00	0.00	0.00	125.00

Paid 122-09-00006407 09/08/2010 125.00

THIS RECEIPT MUST BE POSTED CONSPICUOUSLY IN YOUR PLACE OF BUSINESS

THIS BECOMES A TAX RECEIPT
WHEN VALIDATED

Danise D. Henriquez, CFC, Tax Collector
PO Box 1129, Key West, FL 33041

THIS IS ONLY A TAX.
YOU MUST MEET ALL
COUNTY AND/OR
MUNICIPALITY PLANNING
AND ZONING REQUIREMENTS.

**2010 / 2011
MONROE COUNTY BUSINESS TAX RECEIPT
EXPIRES SEPTEMBER 30, 2011**

RECEIPT# 46110-89800

Business Name: CHARLEY TOPPINO & SONS, INC.

Owner Name: EDWARD TOPPING, SR.
Mailing Address: P O BOX 787
KEY WEST, FL 33040

Business Location: 8.5 ROCKLAND KEY

Business Type: PROFESSIONALS (ENG CLASS I CC 749 A)

Rooms Seats Employees Machines Stalls

Tax Amount	Transfer Fee	Sub Total	Penalty	Priority Fee	Collection Cost	Total Paid
30.00	0.00	30.00	0.00	0.00	0.00	30.00

Paid 122-09-00006409 08/20/10 30.00

THIS RECEIPT MUST BE POSTED CONSPICUOUSLY IN YOUR PLACE OF BUSINESS

THIS BECOMES A TAX RECEIPT
WHEN VALIDATED

Danise D. Henriquez, CFC, Tax Collector
PO Box 1129, Key West, FL 33041

THIS IS ONLY A TAX.
YOU MUST MEET ALL
COUNTY AND/OR
MUNICIPALITY PLANNING
AND ZONING REQUIREMENTS.

**2010 / 2011
MONROE COUNTY BUSINESS TAX RECEIPT
EXPIRES SEPTEMBER 30, 2011**

RECEIPT# 53110-25514

Business Name: ROCKLAND RECYCLING CENTER ENERGY
COMMONS INC DBA

Owner Name: FRANK & EDWARD GEORGE TOPPING Business Location: MM 8.5 US HWY 1

Mailing Address: P O BOX 1149
KEY WEST, FL 33041

Business Phone: 305-296-5606
Business Description: WHOLESALE SALES (RECYCLING CONST
DEBRIS)

Rooms

Employees

Tables

Stalls

Tax Amount	Transfer Fee	Penalty	Prior Year	Collection Cost	Total Paid
30.00	0.00	0.00	0.00	0.00	30.00

Paid 122-09-00006411 09-08-2010 30.00

THIS RECEIPT MUST BE POSTED CONSPICUOUSLY IN YOUR PLACE OF BUSINESS

THIS BECOMES A TAX RECEIPT
WHEN VALIDATED

**Danise D. Henriquez, CFC, Tax Collector
PO Box 1129, Key West, FL 33041**

THIS IS ONLY A TAX.
YOU MUST MEET ALL
COUNTY AND/OR
MUNICIPALITY PLANNING
AND ZONING REQUIREMENTS.



Florida Department of Transportation

CHARLIE CRIST
GOVERNOR

605 Suwannee Street
Tallahassee, FL 32399-0450

STEPHANIE C. KOPELOUSOS
SECRETARY

May 17, 2010

CHARLEY TOPPINO & SONS, INC.
PO BOX 787
KEY WEST FLORIDA 33041

RE: CERTIFICATE OF QUALIFICATION

Dear Sir/Madam:

The Department of Transportation has qualified your company for the amount and the type of work indicated below. Unless your company is notified otherwise, this rating will expire 6/30/2011. However, the new application is due 4/30/2011.

In accordance with S.337.14 (1) F.S. your next application must be filed within (4) months of the ending date of the applicant's audited annual financial statements and, if applicable, the audited interim financial statements. Section 337.14 (4) F.S. provides that your certificate will be valid for 18 months after your financial statement date. This gives a two month period to allow you to bid on jobs as we process your new application for qualification. To remain qualified with the Department, a new application must be submitted subsequent to any significant change in the financial position or the structure of your firm as described in Section 14-22.005(3), Florida Administrative Code.

MAXIMUM CAPACITY RATING: \$392,950,000.00

FDOT APPROVED WORK CLASSES:

DEBRIS REMOVAL (EMERGENCY), DRAINAGE, FLEXIBLE PAVING, GRADING, GRASSING, SEEDING AND SODDING, INTERMEDIATE BRIDGES, MINOR BRIDGES, ROADWAY SIGNING

FDOT APPROVED SPECIALITY CLASSES OF WORK:

UNDERGROUND UTILITIES, SIDEWALKS CONCRETE CURB.

Please be advised the Department of Transportation has considered your company's qualification in all work classes requested. We have evaluated your company's organization, management, work experience, work performance and adequacy of equipment as directed by section 14-22.003, Florida Administrative Code. Based on this evaluation, the Department is not able, at this time, to prequalify your company for the work classes: R&R INTERMEDIATE BRIDGES, R&R MINOR BRIDGES.

CHARLEY TOPPINO & SONS, INC.

May 17, 2010

Page two

You may apply, in writing, for a Revised Certificate of Qualification at any time prior to the expiration date of this certificate according to Section 14-22.0041(3), Florida Administrative Code. Please be advised if certification in additional classes of work is desired, documentation is needed to show that your company has done such work with your own forces and equipment or that experience was gained with another contractor and that you have the necessary equipment for each additional class of work requested.

Sincerely,

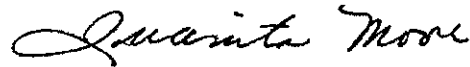
A handwritten signature in cursive script that reads "Juanita Moore".

Juanita Moore, Manager
Contracts Administration Office

JM:cj



THE CITY OF KEY WEST

Post Office Box 1409 Key West, FL 33041-1409 (305) 809-3867

ADDENDUM # 1 COLLEGE ROAD ENHANCEMENTS – GN 0711

March 28, 2011

To All Bidders,

The following changes are hereby made a part of Project number GN 0711, College Road Enhancements, as fully as completely as if the same were fully set forth therein:

Question/Response:

1. **Question:** Will detectable warnings also be included in the area where the 4-foot wide section leading from the bus pad meets the edge of the street?

Response: Yes, it will. Detectable warnings will have an area of 2-ft. deep x 4-ft. wide and will be placed approximately 6 to 8-inches back from the edge of pavement.

2. **Question:** Bridging over structure. Will any wire mesh or equivalent reinforcement be required?

Response: Yes, there will. Longitudinally, #6 bars should be spaced every 6". They should extend 1-foot into the thickened portion before the bridged section. Transversely, #6 bars should be spaced every 12". Please refer to attached sketch below.

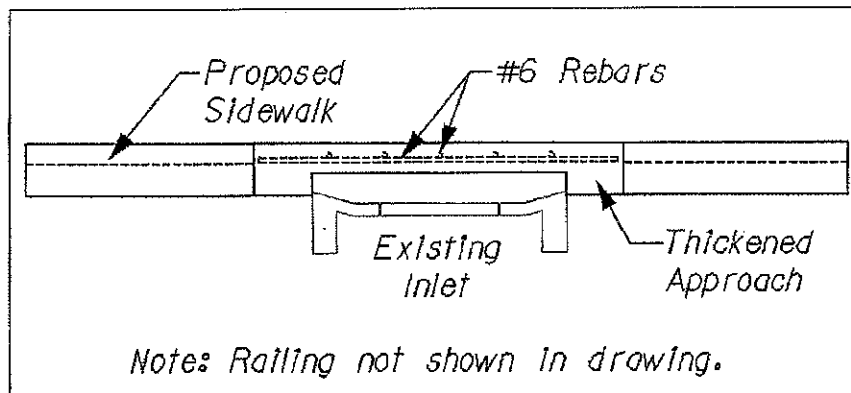

3. **Question:** Will a curb be required on the inside for wheelchair occupants?

Response: No. Please refer to the General Notes, item #1.

Key to the Caribbean – average yearly temperature 77 ° Fahrenheit.

General Notes:

1. Sheet C-12: Construction Details show the use of an aluminum pipe guiderail. This will be changed to an aluminum pedestrian/bicycle picket railing as per 2010 FDOT Design Standards 860, Sheet no. 2 of 5. Height shall be 3'-6" (42"). Please refer to drawing below and the .

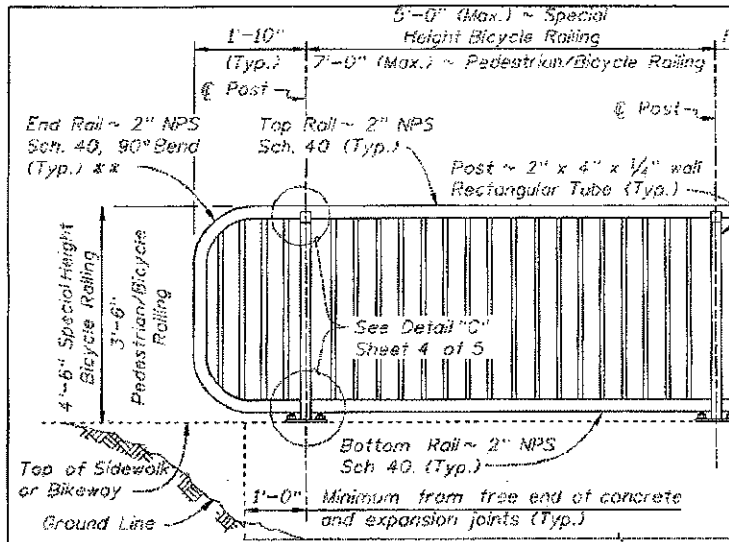

2. An additional Add/Alternate item will be gravel (1/2" to 3/4") with a quantity of **65** Tons. Please refer to following sheet which will replace page 21 of the Bid Documents package. In addition, please refer to sheets C-07 and C-08 at end of addendum denoting where swales will be incorporated.

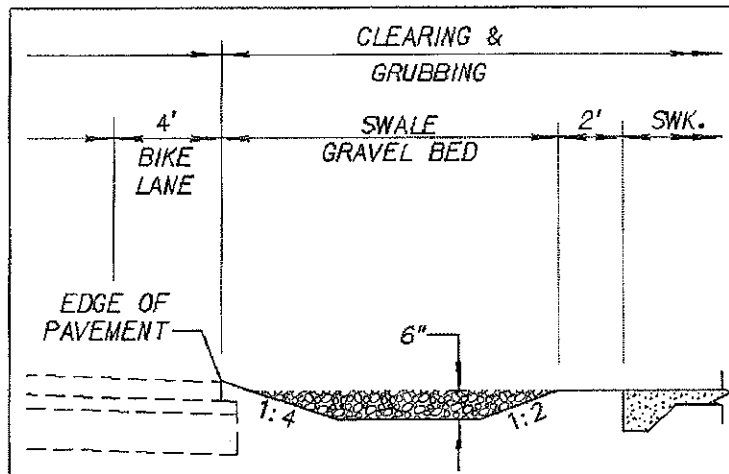

3. Please note that the number of shelters has been reduced from six (6) to two (2). These shelters are located at Sta. 18+71.60 and Sta. 24+95.80.
4. Please note that the 26.65-ft. long 5-ft. wide path leading to the bus stop at station 10+65.10 on sheet C-05 is no longer required. This item may be removed from the total quantity of concrete required.

Key to the Caribbean – average yearly temperature 77 ° Fahrenheit.

ADD/ALTS 1-4

Add Alternates are not a part of the base bid and shall only be added to the contract at the owners discretion.

<u>Item</u>	<u>Quant.</u>	<u>Unit</u>	<u>UP (Fig)</u>	<u>UP (Words)</u>	<u>Extended Total Amount</u>
1). Seepage Trench					
	100	LF	\$ _____	_____	\$ _____
2). Striping (White retro-reflective 6", as required)					
	0.6	NM	\$ _____	_____	\$ _____
3). Bus Shelters					
	2	EA	\$ _____	_____	\$ _____
4). Gravel Stone, 1/2 inch to 3/4 inch diameter (includes cost of material and labor to excavate 6" deep shoulder, grade bottom of shoulder, and backfill. Gravel will be for use in specified areas between edge of pavement and front of sidewalk as directed by the engineer).					
	65	TONS	\$ _____	_____	\$ _____

TOTAL OF ADD/ALT UNIT PRICE ITEMS LISTED ABOVE

\$ _____ Dollars and _____ Cents
(Amount Written in Words has Precedence)

Key to the Caribbean – average yearly temperature 77 ° Fahrenheit.

All Bidders shall acknowledge receipt and acceptance of this Addendum NO. 1 by acknowledging Addendum in their proposal or by submitting the addendum with the bid package. Bids submitted without acknowledgement or without this Addendum may be considered non-responsive.

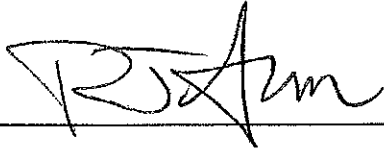
A handwritten signature in black ink, appearing to read 'R. J. Toppino', written over a horizontal line.

Signature

CHARLEY TOPPINO & SONS, INC.

Name of Business



THE CITY OF KEY WEST

Post Office Box 1409 Key West, FL 33041-1409 (305) 809-3867

ADDENDUM # 1
COLLEGE ROAD ENHANCEMENTS – GN 0711

March 29, 2011

To All Bidders,

The following changes are hereby made a part of Project number GN 0711, College Road Enhancements, as fully as completely as if the same were fully set forth therein:

The bid opening date has been extended to WEDNESDAY APRIL 13, 2011 at 3:30 p.m.

Question/Response:

1. **Question:** Will detectable warnings also be included in the area where the 4-foot wide section leading from the bus pad meets the edge of the street?

Response: Yes, it will. Detectable warnings will have an area of 2-ft. deep x 4-ft. wide and will be placed approximately 6 to 8-inches back from the edge of pavement.

2. **Question:** Bridging over structure. Will any wire mesh or equivalent reinforcement be required?

Response: Yes, there will. Longitudinally, #6 bars should be spaced every 6". They should extend 1-foot into the thickened portion before the bridged section. Transversely, #6 bars should be spaced every 12". Please refer to attached sketch below.

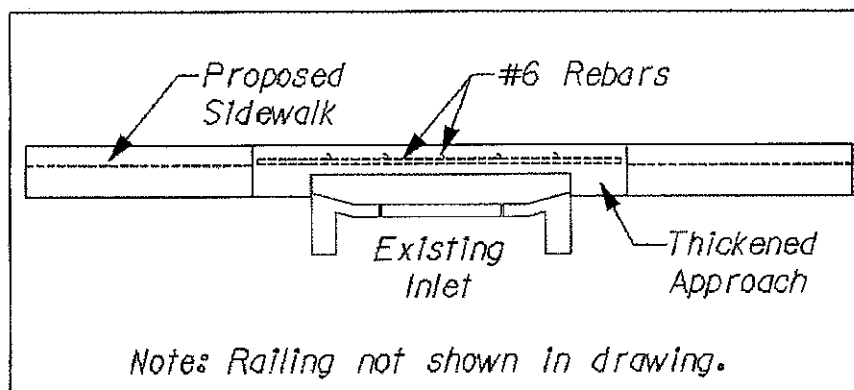

Key to the Caribbean – average yearly temperature 77 ° Fahrenheit.

3. **Question:** Will a curb be required on the inside for wheelchair occupants?

Response: No. Please refer to the General Notes, item #1.

General Notes:

1. Sheet C-12: Construction Details show the use of an aluminum pipe guiderail. This will be changed to an aluminum pedestrian/bicycle picket railing as per 2010 FDOT Design Standards 860, Sheet no. 2 of 5. Height shall be 3'-6" (42"). Please refer to drawing below and the .

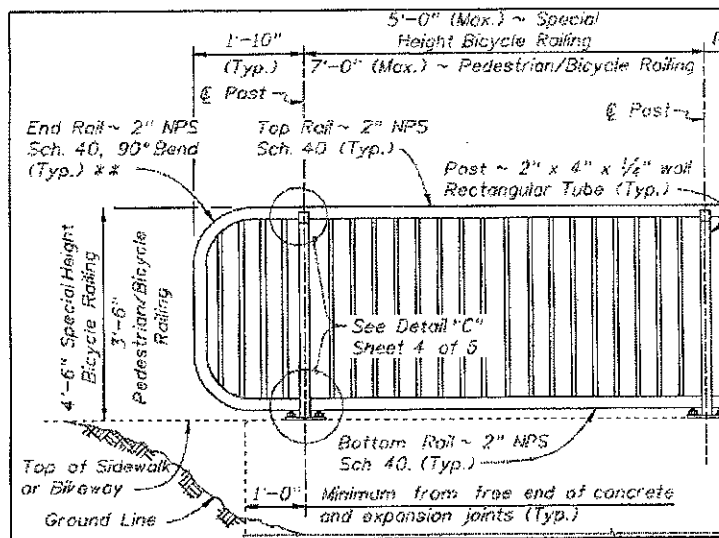

2. An additional Add/Alternate item will be gravel (1/2" to 3/4") with a quantity of 65 Tons. Please refer to following sheet which will replace page 21 of the Bid Documents package. In addition, please refer to sheets C-07 and C-08 at end of addendum denoting where swales will be incorporated.

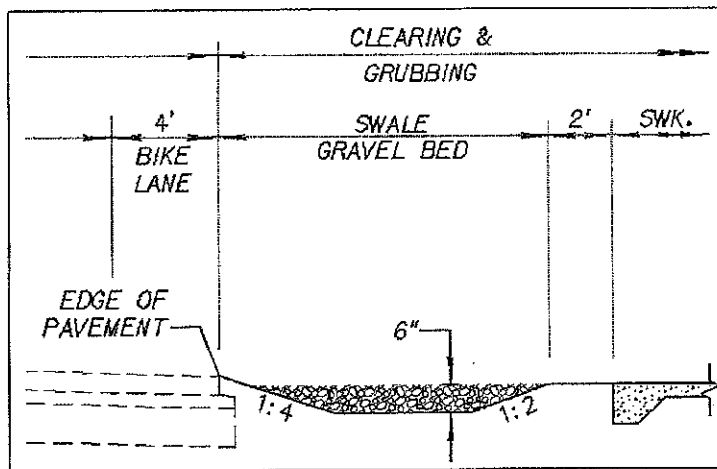

Key to the Caribbean -- average yearly temperature 77 ° Fahrenheit.

3. Please note that the number of shelters has been reduced from six (6) to two (2). These shelters are located at Sta. 18+71.60 and Sta. 24+95.80.
4. Please note that the 26.65-ft. long 5-ft. wide path leading to the bus stop at station 10+65.10 on sheet C-05 is no longer required. This item may be removed from the total quantity of concrete required.

ADD/ALTS 1-4

Add Alternates are not a part of the base bid and shall only be added to the contract at the owners discretion.

<u>Item</u>	<u>Quant.</u>	<u>Unit</u>	<u>UP (Fig)</u>	<u>UP (Words)</u>	<u>Extended Total Amount</u>
1). Seepage Trench					
	100	LF	\$ _____	_____	\$ _____
2). Striping (White retro-reflective 6", as required)					
	0.6	NM	\$ _____	_____	\$ _____
3). Bus Shelters					
	2	EA	\$ _____	_____	\$ _____
4). Gravel Stone, 1/2 inch to 3/4 inch diameter (includes cost of material and labor to excavate 6" deep shoulder, grade bottom of shoulder, and backfill. Gravel will be for use in specified areas between edge of pavement and front of sidewalk as directed by the engineer).					
	65	TONS	\$ _____	_____	\$ _____

TOTAL OF ADD/ALT UNIT PRICE ITEMS LISTED ABOVE

\$ _____ Dollars and _____ Cents
 (Amount Written in Words has Precedence)



SCALE: 1"=50'

660 SF x 0.5 ft = 330 CF = 18.2 CY
 USE [18 CY]
 18 CY @ 1.5 TONS = 27 TONS = 19.5 TONS
 18 CY @ 1.5 TONS = 27 TONS = 19.5 TONS

Tree/ Shrub	Species	Common Name	Remove/ Retain
①	<i>Balanites aegyptiaca</i>	Live Oak (Mediterranean)	Remove
②	<i>Balanites aegyptiaca</i>	Green Buttonwood	Remove
③	<i>Coccoloba erecta</i>	Green Buttonwood	Remove
④	<i>Coccoloba erecta</i>	Silver Buttonwood	Remove
⑤	<i>Coccoloba erecta</i>	Silver Buttonwood	Remove

RAW LINE

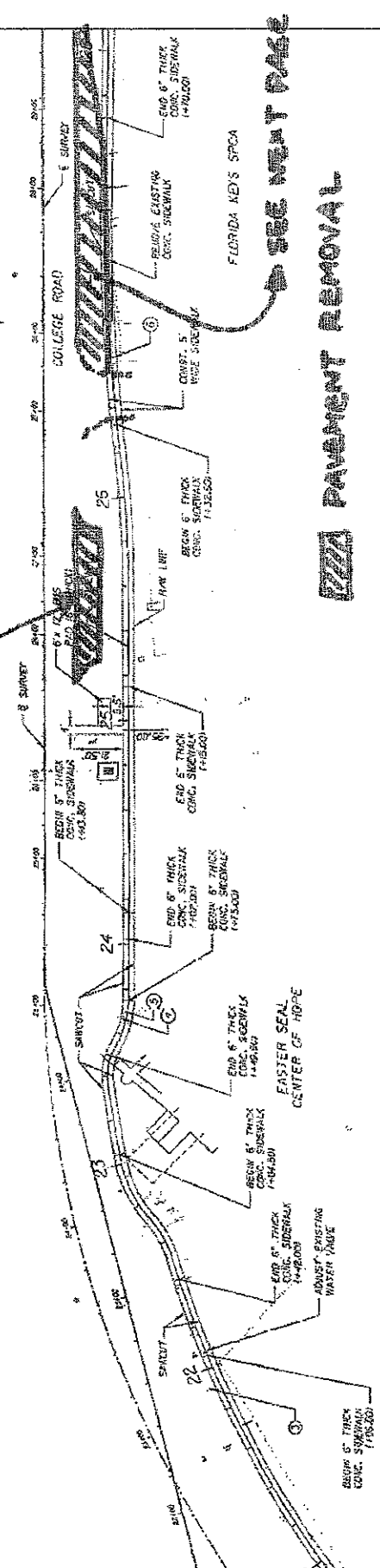

PAVEMENT REMOVAL

SEE NEXT PAGE

PLAN SHEET 3 OF 5

PREPARED BY: [Blank]		DATE: [Blank]	
APPROVED BY: [Signature]		DATE: [Blank]	
PROJECT NO.: 1001200			
SCALE: 1" = 50'			
DATE: 07/01/10			
BY: [Blank]			
CHECKED: [Blank]			
CAD FILE: [Blank]			
BEHNELLO, JAVIL & PARTNERS, INC. ARCHITECTS - PLANNERS - LANDSCAPE ARCHITECTS - INTERIOR DESIGN 2801 E. BAYSHORE DRIVE, 3RD FLOOR MIAMI FL, 33133 (305) 863-2000 FAX: (305) 863-1174		ba	
SHEET NO.: C-07			



SUNSET MARINA ROAD

1790 SF x 0.5 ft = 895 CF = 33.15 CY → USE **35 CY**
 35 CY x 1.3 TONS = **45.5 TONS**
 45.5 TONS = 45.5 TONS
 45.5 TONS = 45.5 TONS

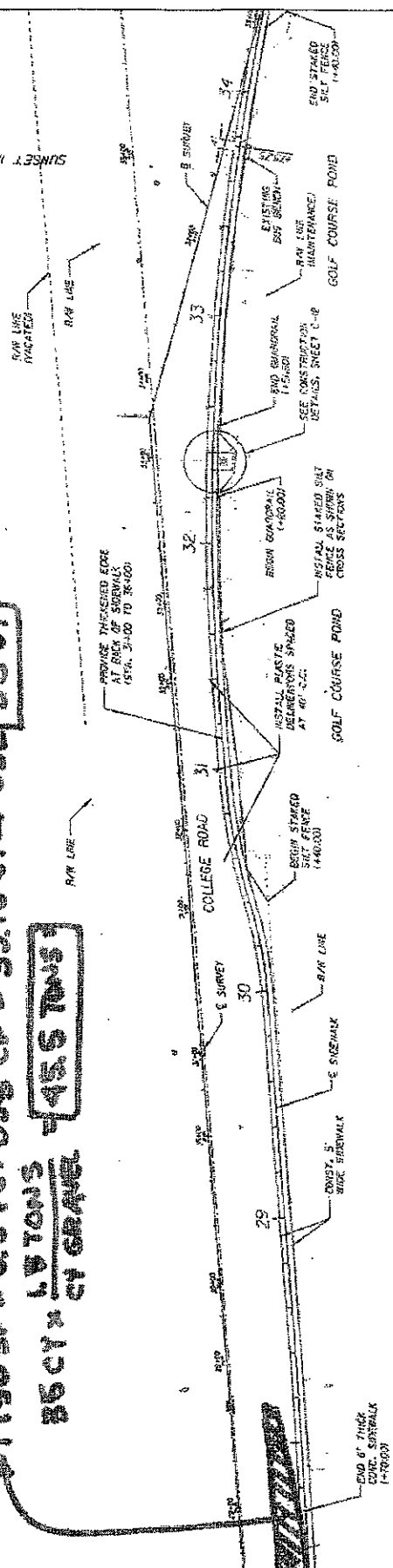

PAVEMENT REMOVAL KEY WEST GOLF CLUB

PLAN SHEET 4 OF 5

REVISIONS 1. _____ 2. _____ 3. _____ 4. _____ 5. _____ 6. _____		APPROVED BY: FRANCIS J. JESSE, PE REGISTERED ENGINEER NO. 8788 STATE OF FLORIDA DATE:	DESIGN: DATE:	DRAWN: CHECKED: PLOTTED FILE:	CONA NO.: DATE: DRAWN: CHECKED: PLOTTED FILE:	 REG. NO. 1014071	 REG. NO. 1014071	COLLEGE ROAD ENHANCEMENTS SHEET NO. C-08
ba BERNIELLO JAVAIL & PARTNERS, INC. LANDSCAPE ARCHITECTURE - HORTICULTURE DIV. 2001 S. BAYSHORE DRIVE, 3RD FLOOR JAVAIL FL, 33133 (305) 495-2332 FAX: (305) 495-2378		PLAN SHEET 4 OF 5						

All Bidders shall acknowledge receipt and acceptance of this Addendum NO. 1 by acknowledging Addendum in their proposal or by submitting the addendum with the bid package. Bids submitted without acknowledgement or without this Addendum may be considered non-responsive.

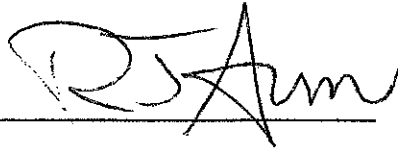
A handwritten signature in black ink, appearing to read "R. J. Am", written over a horizontal line.

Signature

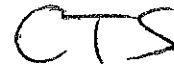
The handwritten letters "CTS" in black ink, written over a horizontal line.

Name of Business

RESOLUTION NO. 08-102

A RESOLUTION OF THE CITY COMMISSION OF THE CITY OF KEY WEST, FLORIDA, APPROVING TWO (2) LOCAL AGENCY PROGRAM AGREEMENTS (LAP) BETWEEN THE CITY AND THE FLORIDA DEPARTMENT OF TRANSPORTATION (FDOT); (1) IN THE AMOUNT OF \$425,002.00, FOR FDOT PROJECT # 422718-1 FOR ELEVATION OF APPROXIMATELY 500 FEET OF THE CURRENT ROAD BED ALONG NORTHSIDE DRIVE FROM KENNEDY DRIVE TOWARD GLYNN ARCHER DRIVE (CITY SHARE - 12.5%); (2) IN THE AMOUNT OF \$281,931.00 FOR FDOT PROJECT # 421379-1 FOR INSTALLATION OF A BIKE/PEDESTIAN PATH, ALONG WITH PAVEMENT AND BUS STOP IMPROVEMENTS ALONG COLLEGE ROAD; PROVIDING FOR AN EFFECTIVE DATE

BE IT RESOLVED BY THE CITY COMMISSION OF THE CITY OF KEY WEST, FLORIDA, AS FOLLOWS:

Section 1: That the two attached FDOT LAP agreements are hereby approved.

Section 2: That this Resolution shall go into effect immediately upon its passage and adoption and authentication by the signature of the presiding officer and the Clerk of the Commission.

Passed and adopted by the City Commission at a meeting held
this _____ 1st _____ day of _____ April _____, 2008.

Authenticated by the presiding officer and Clerk of the
Commission on _____ April 2 _____, 2008.

Filed with the Clerk _____ April 2 _____, 2008.

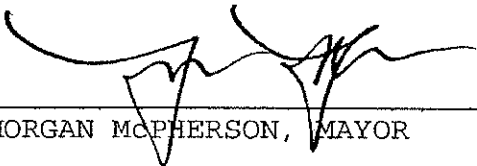

MORGAN MCPHERSON, MAYOR

ATTEST:



CHERYL SMITH, CITY CLERK

RESOLUTION NO. 10-234

A RESOLUTION OF THE CITY COMMISSION OF THE CITY OF KEY WEST, FLORIDA, APPROVING THE ATTACHED MODIFICATION TO EXHIBIT B OF THE LOCAL AGENCY PROGRAM AGREEMENT - FM NO. 421379-1/GN0711, BETWEEN THE CITY AND THE FLORIDA DEPARTMENT OF TRANSPORTATION (FDOT) FOR COLLEGE ROAD IMPROVEMENTS IN THE TOTAL AMOUNT OF \$325,000.00; PROVIDING FOR AN EFFECTIVE DATE

WHEREAS, it is necessary to acknowledge that funding was increased by FDOT on these projects, prior to execution of the LAP Agreement approved in Resolution 08-102;

NOW, THEREFORE, BE IT RESOLVED BY THE CITY COMMISSION OF THE CITY OF KEY WEST, FLORIDA, AS FOLLOWS:

Section 1: That the attached Modification to Exhibit B of Local Agency Program Agreement is hereby approved.

Section 2: That this Resolution shall go into effect immediately upon its passage and adoption and authentication by the signature of the presiding officer and the Clerk of the Commission.

Passed and adopted by the City Commission at a meeting held
this 3rd day of August, 2010.

Authenticated by the presiding officer and Clerk of the
Commission on August 4, 2010.

Filed with the Clerk August 4, 2010.



CRAIG CATES, MAYOR

ATTEST

CHERYL SMITH, CITY CLERK