

# Historic Architectural Review Commission

## Staff Report Item 7

---

<b>Meeting Date:</b>	November 25, 2014
<b>Applicant:</b>	Carlos Rojas, Architect
<b>Application Number:</b>	H14-01-1750
<b>Address:</b>	#1016 James Street
<b>Description of Work:</b>	Construction of new scooter carport over parking area on Thompson Lane.
<b>Building Facts:</b>	The site in review contains a contributing resource, a frame vernacular house built c. 1899 and first appears on the 1912 Sanborn map. The house fronts James Street, but its rear faces on Thompson Lane.
<b>Guidelines Cited in Review:</b>	Outbuildings (pages 40-41), specifically first two paragraphs of page 40 and guidelines 1 through 9 of page 40.

### Staff Analysis

The Certificate of Appropriateness in review proposes the construction of a frame structure to be used as a scooter carport. The structure will be placed over existing car parking and set back one foot from the property line. The new scooter carport structure will connect to an existing equipment shed. Inside the existing shed is A/C units, not a washer and dryer, as indicated on the plans. The proposed carport will be 9' high from grade and its roof will be covered with metal v-crimp.

To complete this project, the existing fence that shields the equipment shed will be moved to the property line with gates that open onto the lane.

### Consistency with the Guidelines

1. Construction of excessive outbuildings detracts from the quality of a historic neighborhood and lessens its intended appearance and historical design.

2. Carports are not appropriate in the historic district when they are highly visible from the right-of-way.
3. Although the carport will have a harmonious scale, it will front right on Thompson Lane. There is another carport on the street, but it is set back eight feet from the street.

It is staff's opinion that the proposed scooter carport will be highly visible from the lane, which is a public right-of-way, and therefore is not appropriate. There are a few historic houses that face this lane, and the creation of more carports will detract from their intended appearance and historical design.

# Application



**CITY OF KEY WEST  
BUILDING DEPARTMENT  
CERTIFICATE OF APPROPRIATENESS** 03-2014 011750  
APPLICATION # \_\_\_\_\_

OWNER'S NAME: **Bernard Hyman** DATE: **11/3/14**

OWNER'S ADDRESS: **1016 James Street Key West** PHONE #: **3052924870**

APPLICANT'S NAME: **Carlos Rojas AIA** PHONE #: **3059233567**

APPLICANT'S ADDRESS: **2012 Roosevelt Drive Key West**

ADDRESS OF CONSTRUCTION: **1016 James Street Key West** # OF UNITS: **1**

**THERE WILL BE A FINAL INSPECTION REQUIRED UNDER THIS PERMIT**

**DETAILED DESCRIPTION OF WORK:**

Add a covered addition (8x12) to laundry room at rear of property for scooter parking. Move existing rear fence and gate to rear property line. Made of wood with v-crimp roof

*Chapter 837.06 F.S.-False Official Statements – Whoever knowingly makes a false statement in writing with the intent to mislead a public servant in the performance of his or her official duty shall be guilty of a misdemeanor of the second degree punishable as provided for in s. 775.082 or 775.083*

This application for Certificate of Appropriateness must precede applications for building permits, right of way permits, variances, and development review approvals. Applications must meet or exceed the requirements outlined by the Secretary of the Interior's Standards for Rehabilitation and Key West's Historic Architectural Guidelines.

Once completed, the application shall be reviewed by staff for completeness and either approved or scheduled for presentation to the Historic Architectural Review Commission at the next available meeting. The applicant must be present at this meeting. The filing of this application does not ensure approval as submitted.

Applications that do not possess the required Submittals will be considered incomplete and will not be reviewed for approval.

Date: 11/3/2014

Applicant's Signature:

**Required Submittals**

<input checked="" type="checkbox"/>	TWO SETS OF SCALED DRAWINGS OF FLOOR PLAN, SITE PLAN AND EXTERIOR ELEVATIONS (for new buildings and additions)
<input type="checkbox"/>	TREE REMOVAL PERMIT (if applicable)
<input checked="" type="checkbox"/>	PHOTOGRAPHS OF EXISTING BUILDING (repairs, rehabs, or expansions)
<input checked="" type="checkbox"/>	PHOTOGRAPHS OF ADJACENT BUILDINGS (new buildings and additions)
<input type="checkbox"/>	ILLUSTRATIONS OF MANUFACTURED PRODUCTS TO BE USED SUCH AS SHUTTERS, DOORS, WINDOWS, PAINT COLOR CHIPS, AND AWNING FABRIC SAMPLES.

**Staff Use Only**

Date: \_\_\_\_\_

Staff Approval: \_\_\_\_\_

Fee Due: \$ \_\_\_\_\_

**HISTORIC ARCHITECTURAL REVIEW APPLICATION**

# HISTORIC ARCHITECTURAL REVIEW COMMISSION USE ONLY

\*\*\*\*\*

Approved

Denied

Deferred

\_\_\_\_\_

Reason for Deferral or Denial:

\_\_\_\_\_  
\_\_\_\_\_  
\_\_\_\_\_  
\_\_\_\_\_

HARC Comments:

\_\_\_\_\_  
\_\_\_\_\_  
\_\_\_\_\_  
\_\_\_\_\_

Limit of Work Approved, Conditions of Approval and/or Suggested  
Changes:

\_\_\_\_\_  
\_\_\_\_\_  
\_\_\_\_\_  
\_\_\_\_\_

Date: \_\_\_\_\_

Signature: \_\_\_\_\_

Historic Architectural  
Review Commission

# **Sanborn Maps**

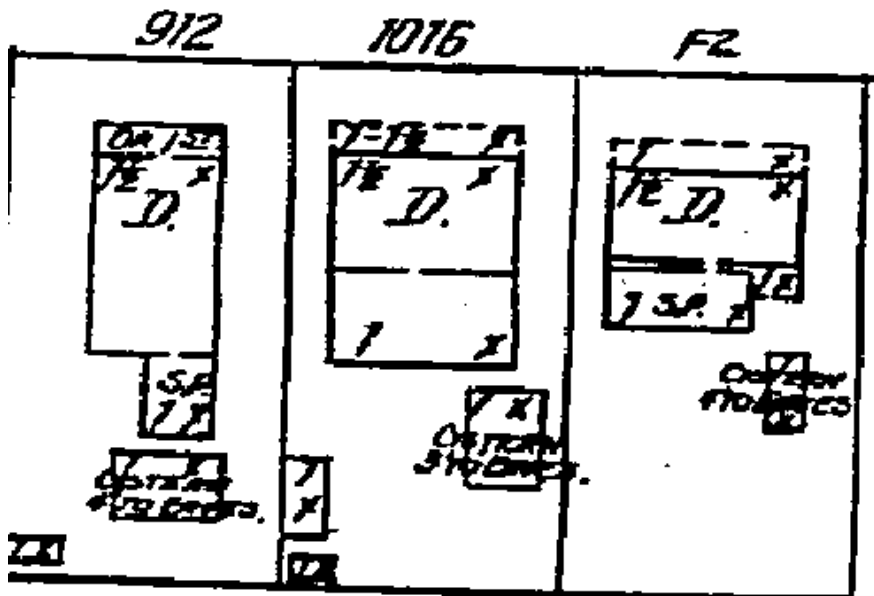

UPTON 19

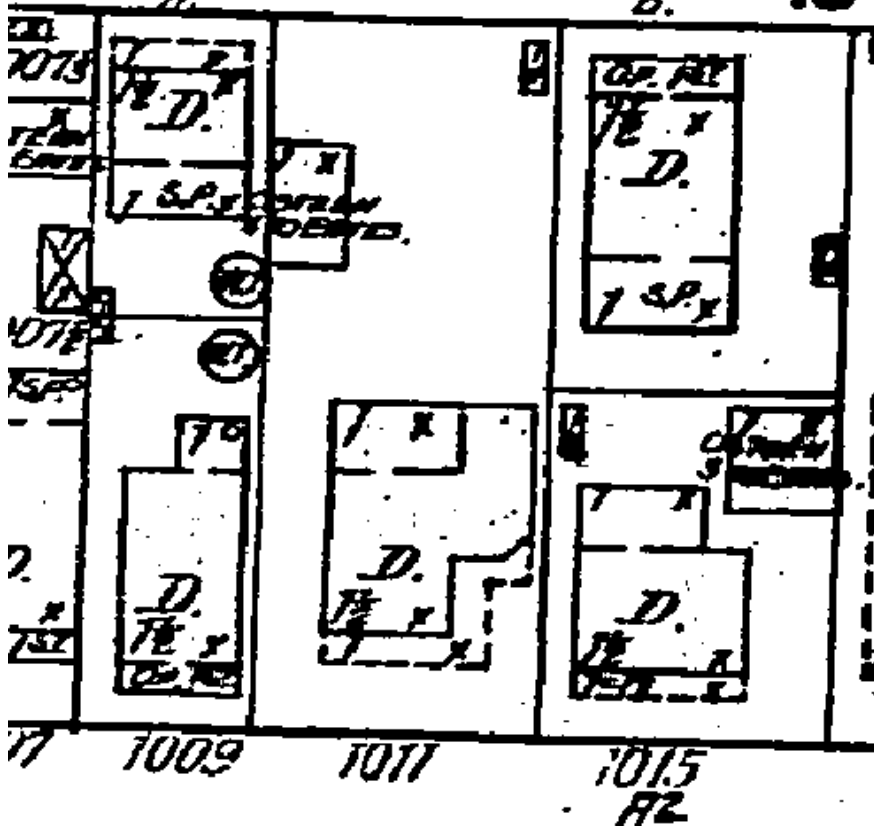

1912 Sanborn Map

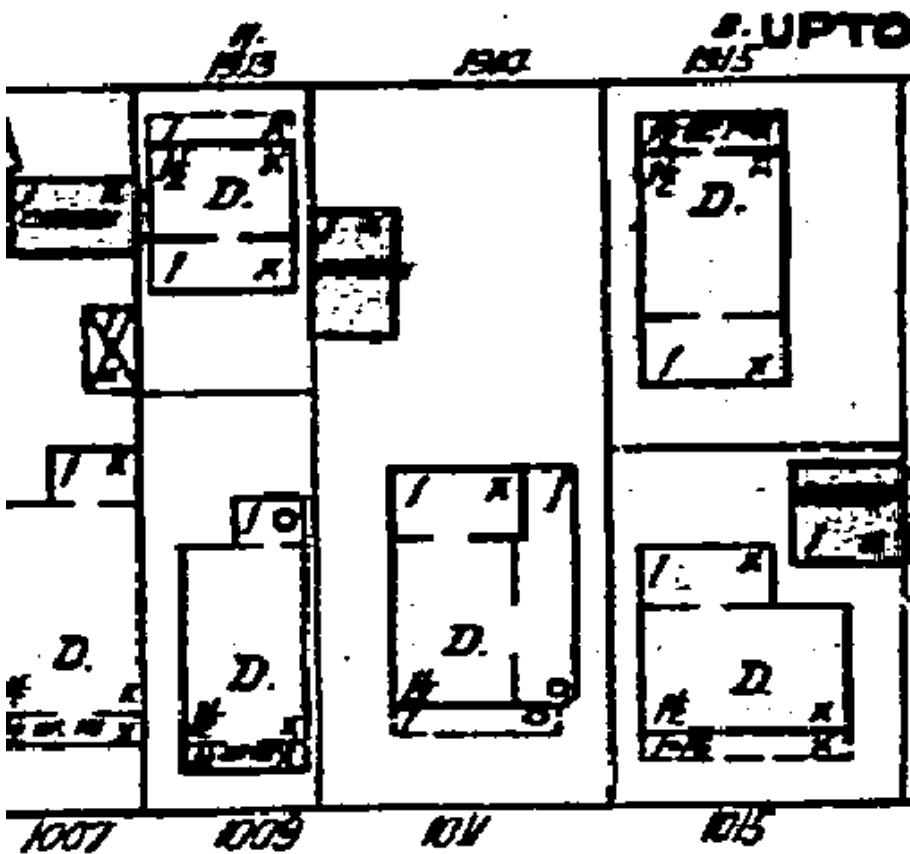
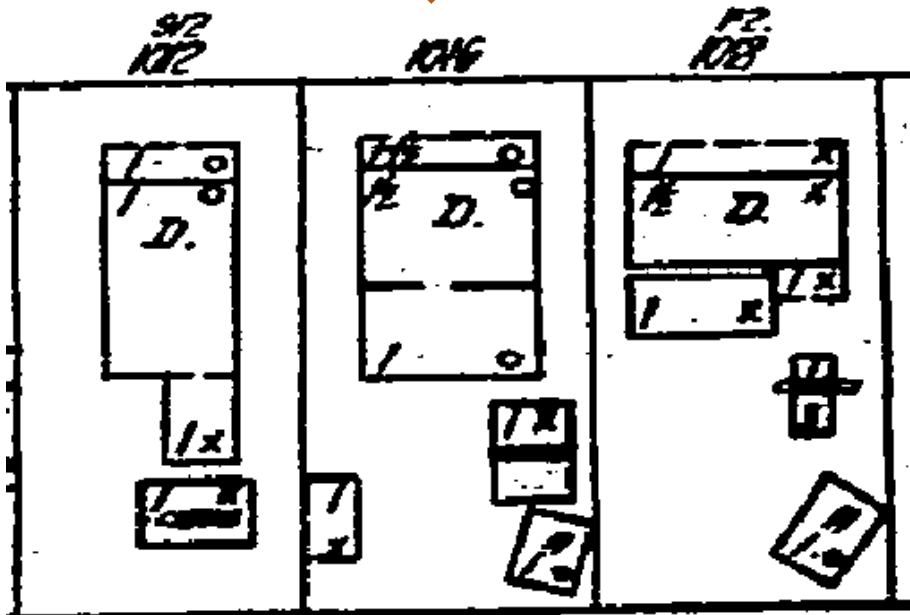

1926 Sanborn Map



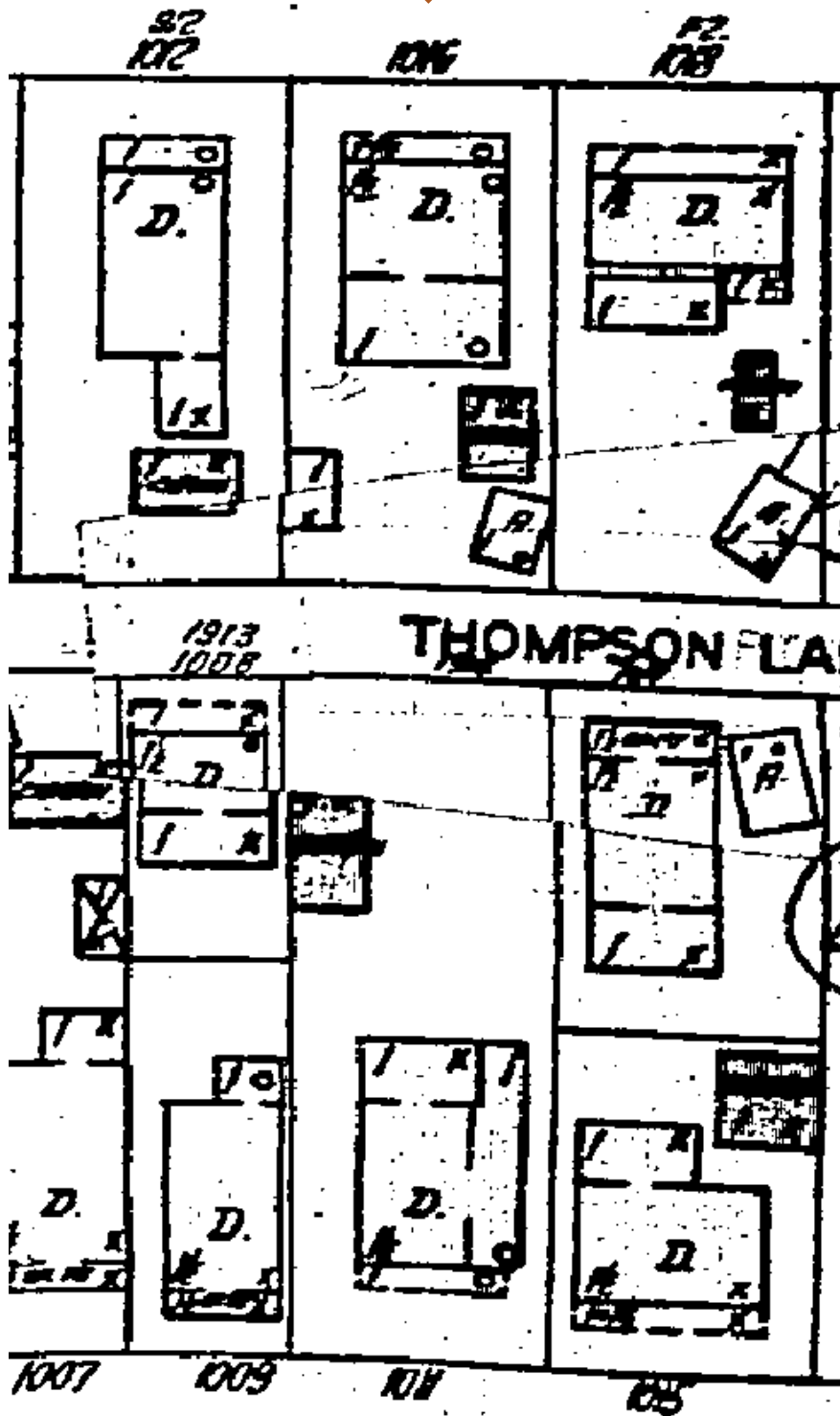

1948 Sanborn Map

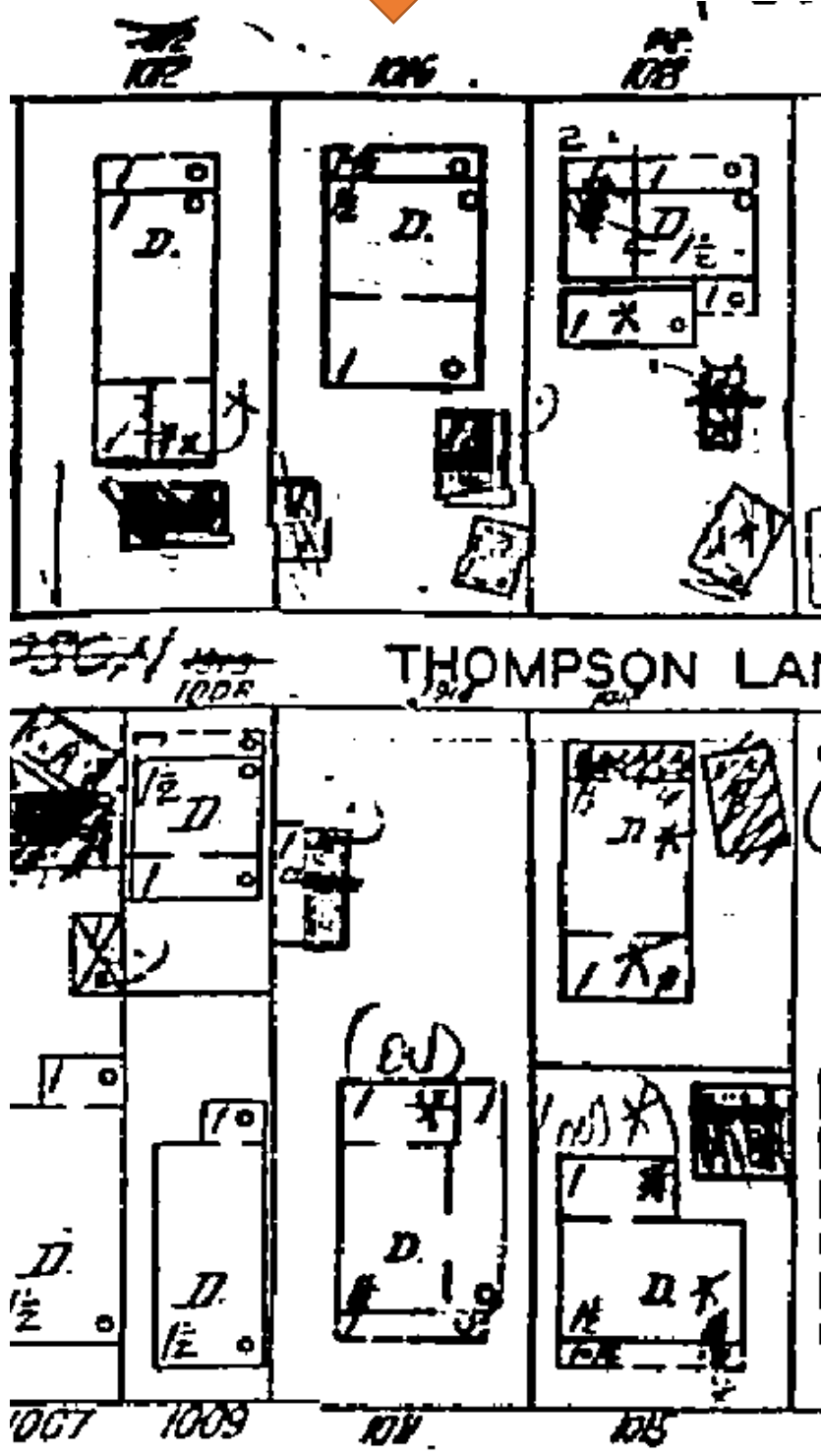

1962 Sanborn Map

# **Project Photos**



Property Appraiser's Photograph, c. 1965.  
Monroe County Public Library.



James Street from 1016 to 1024 looking east to the Pineapple Cannery.  
Gift of OIRC. Monroe County Public Library.



1016

Public Meeting Notice



New carport will extend off that roof line and fence will be moved to property line.



Rear of house. Existing shed structure that holds mechanical equipment.





View of Thompson's Lane. Some houses front this lane



There is an existing carport on Thompson Lane, but it is set back quite a few feet.



Another view of Thompson's Lane.



Another view of Thompson's Lane.

# Survey

Boundary Survey Map of Lot 7 & part of Lot 6, Square 19 according to John Lowe, Jr's Subdivision

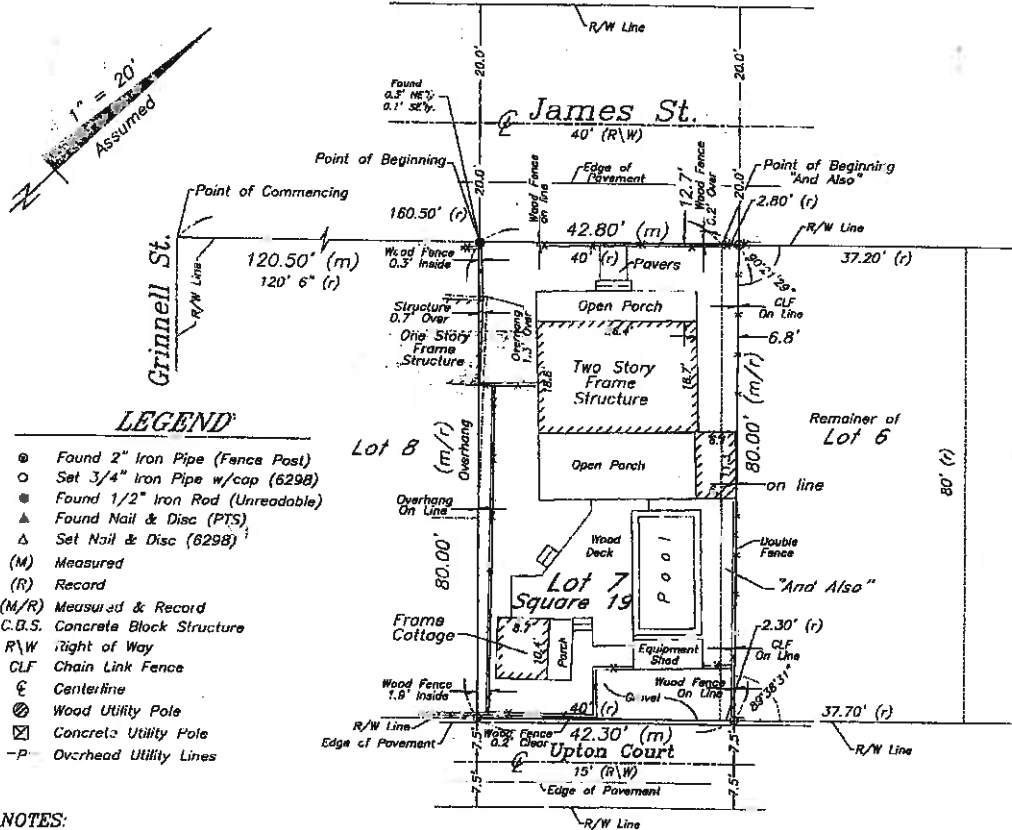

**LEGEND**

- Found 2" Iron Pipe (Fence Post)
- Set 3/4" Iron Pipe w/cap (6298)
- Found 1/2" Iron Rod (Unreadable)
- ▲ Found Nail & Disc (PTS)
- △ Set Nail & Disc (6298)
- (M) Measured
- (R) Record
- (M/R) Measured & Record
- C.B.S. Concrete Block Structure
- R/W Right of Way
- CLF Chain Link Fence
- ⊕ Centerline
- ⊙ Wood Utility Pole
- ⊙ Concrete Utility Pole
- P- Overhead Utility Lines

**NOTES:**

1. The legal description shown hereon was furnished by the client or their agent.
2. Underground foundations and utilities were not located.
3. All angles are 90° (Measured & Record) unless otherwise noted.
4. Street address: 1016 James Street, Key West, FL.
5. This survey is not valid without the signature and the original raised seal of a Florida licensed surveyor and mapper.
6. Lands shown hereon were not abstracted for rights-of-way, easements, ownership, or other instruments of record.
7. North Arrow is assumed and based on the legal description.
8. Adjoiners are not furnished.
9. Date of field work: January 23, 2014
10. Ownership of fences is undeterminable, unless otherwise noted.

**BOUNDARY SURVEY OF:** Lot numbered Seven (7) in Square Nineteen (19) according to John Lowe, Jr's subdivision of said square Nineteen (19) recorded in Plat Book No. 1 on page 24 Monroe County records, said lot Seven (7) commencing One Hundred and Twenty (120) feet and Six (6) inches from the corner of Grinnell and James Streets in the City of Key West, County of Monroe, and State of Florida and running thence along James Street in a Northwesterly direction Forty (40) feet; thence at right angles in a Southeasterly direction Eighty (80) feet; thence at right angles in a Southwesterly direction Forty (40) feet; thence at right angles in a Northwesterly direction Eighty (80) feet; to point of beginning on James Street.

**"AND ALSO"**

A parcel of land on the Island of Key West, and known as part of Lot 6, in Square 19 according to John Lowe, Jr's subdivision of said Square 19, recorded in Plat Book 1, at Page 24, of the Public Records of Monroe County, Florida, said parcel being more particularly described as follows: COMMENCE at the intersection of the NE'y right of way line of Grinnell Street with the SE'y right of way line of James Street and run thence NE'y along the SE'y right of way line of the said James Street for a distance of 160.50 feet to the W'y corner of the said Lot 6, said point also being the Point of Beginning; thence SE'y and at right angles along the SW'y boundary line of the said Lot 6 for a distance of 80.00 feet to the S'y corner of the said Lot 6; thence NE'y and at right angles along the SE'y boundary line of the said Lot 6 for a distance of 2.30 feet; thence NW'y with a deflection angle of 89°38'31" to the left and along existing chain link fence and extensions thereof for a distance of 80.00 feet to the SE'y right of way line of the said James Street; thence SW'y and along the said James Street for a distance of 2.80 feet back to the Point of Beginning.

**BOUNDARY SURVEY FOR:** Bernard Hyman;  
Broad & Cassel;

J. LYNN O'FLYNN, INC.

J. Lynn O'Flynn, PSM  
Florida Reg. #6298

January 31, 2014

THIS SURVEY  
IS NOT  
ASSIGNABLE

J. LYNN O'FLYNN, Inc.



Professional Surveyor & Mapper  
PSM #6298

3430 Duck Ave., Key West, FL 33040  
(305) 298-7422 FAX (305) 298-2244

# **Proposed Design**

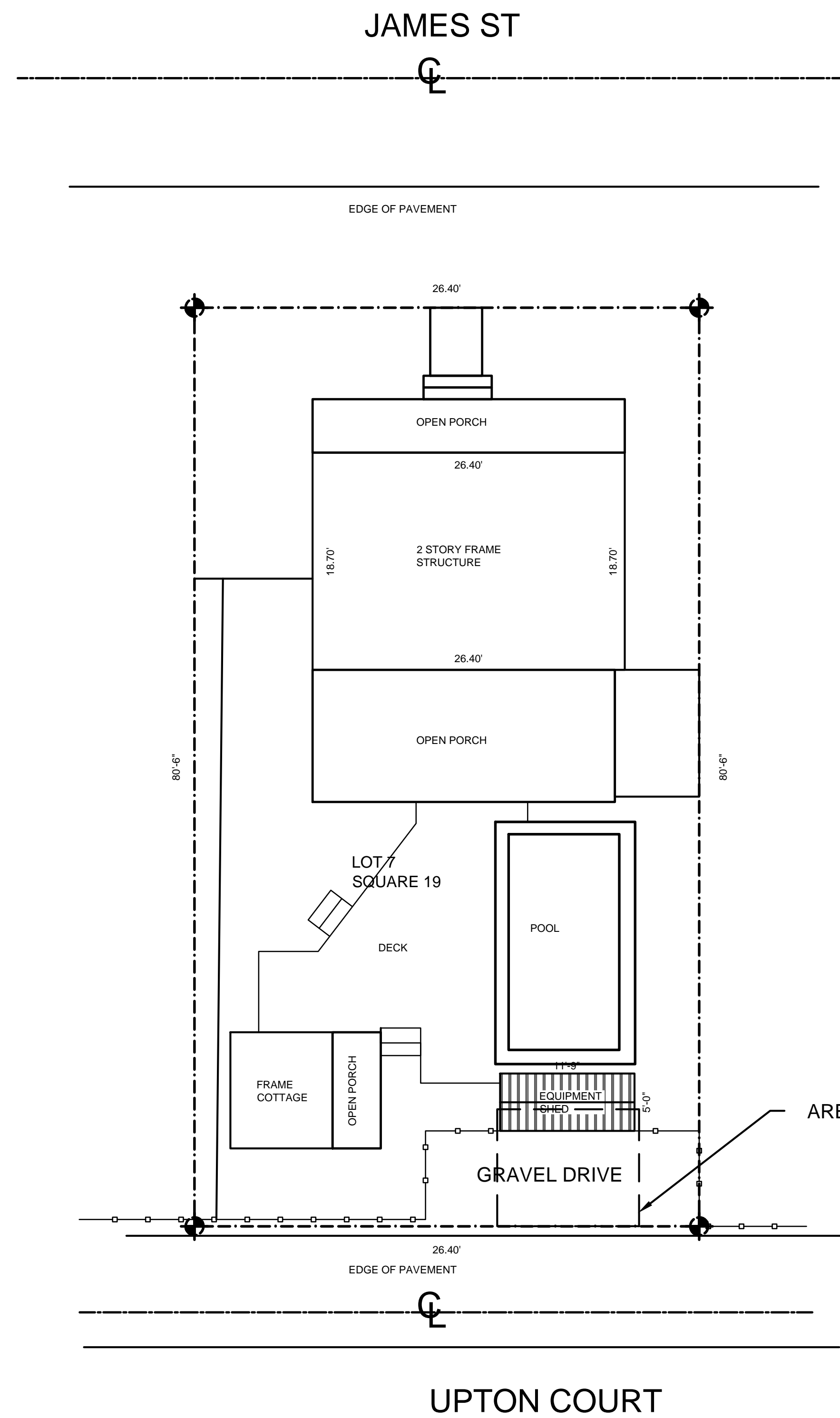

EXISTING SITE PLAN  
1/8"=1'

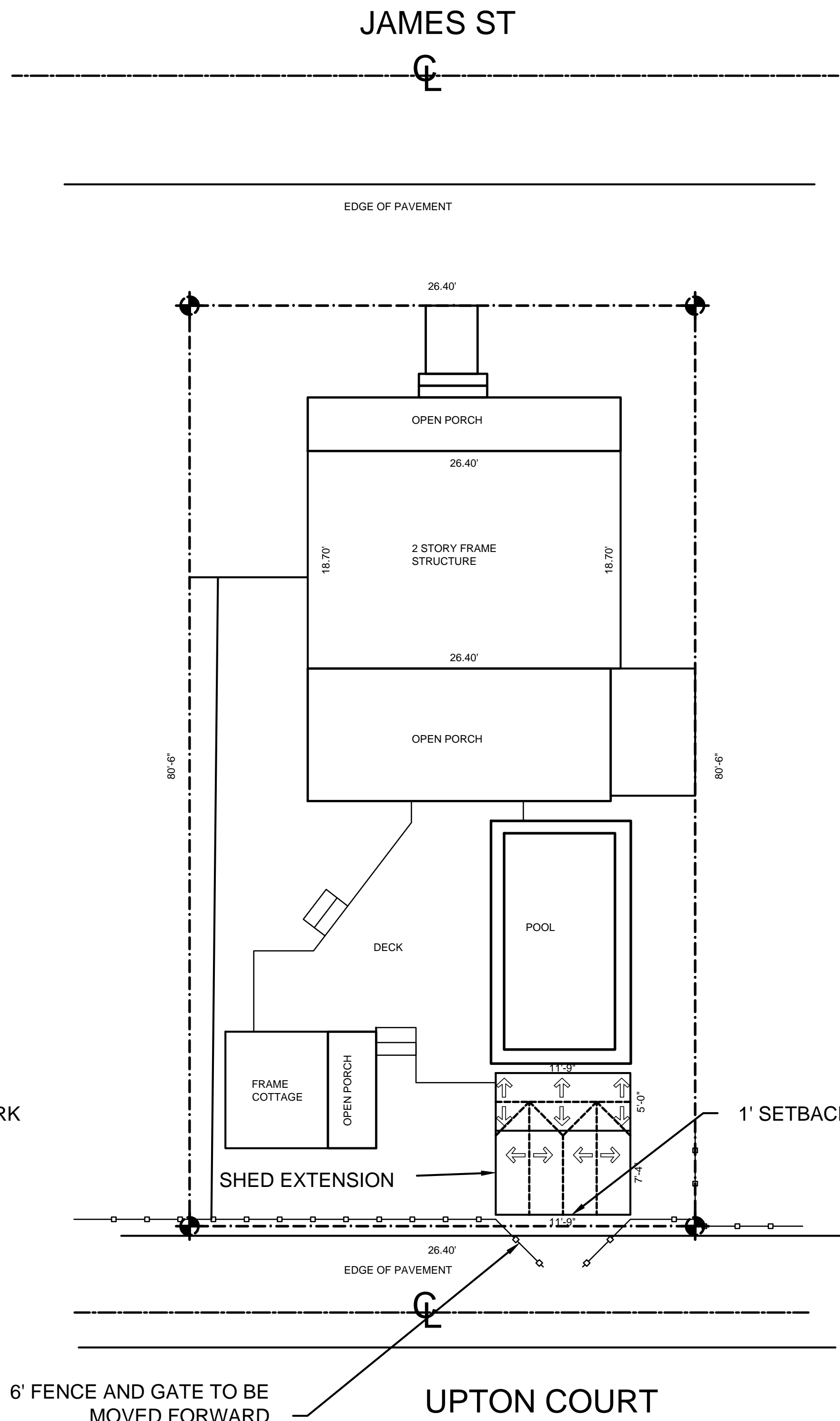

PROPOSED SITE PLAN  
1/8"=1'

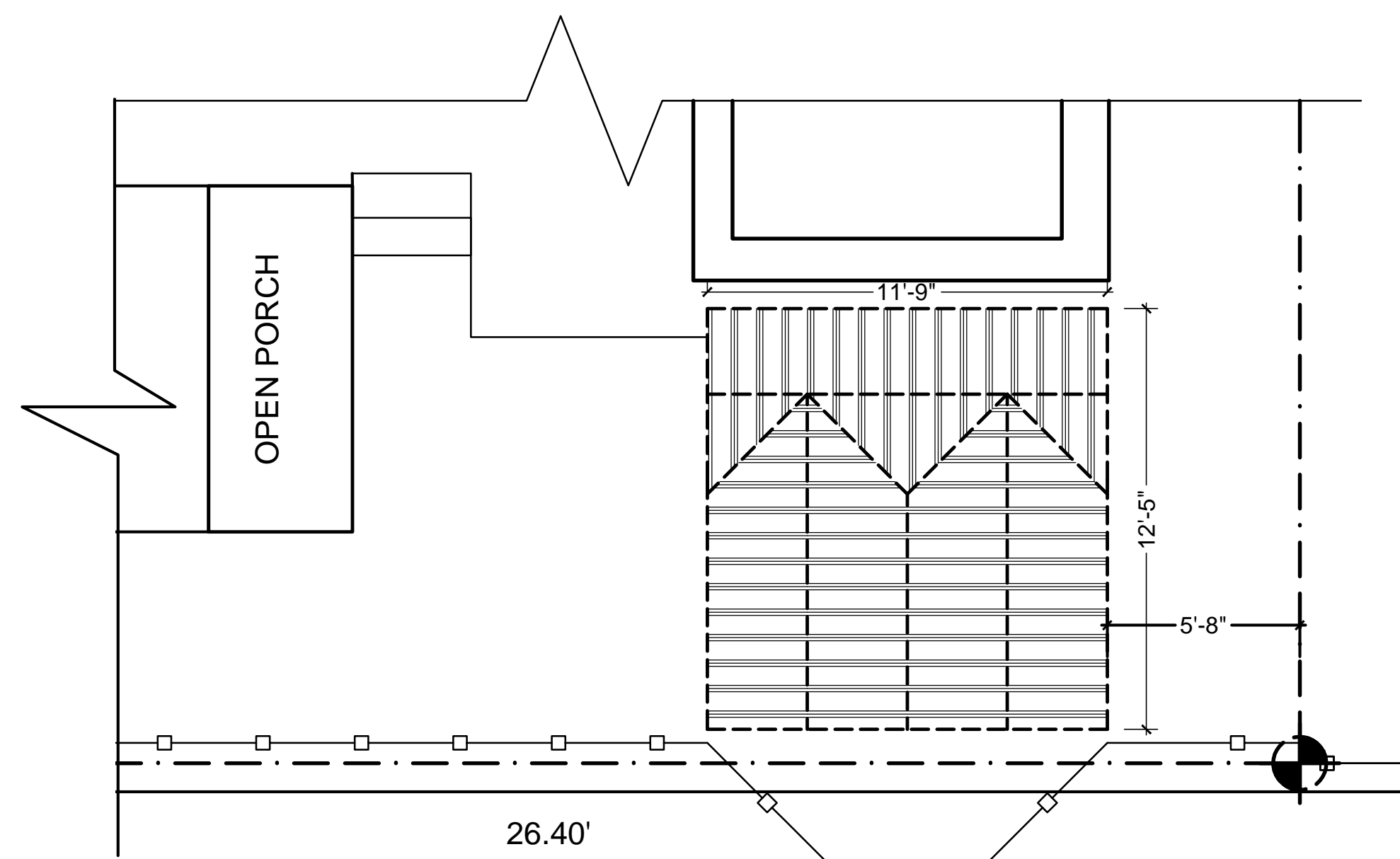

PROPOSED ROOF PLAN  
1/4"=1'

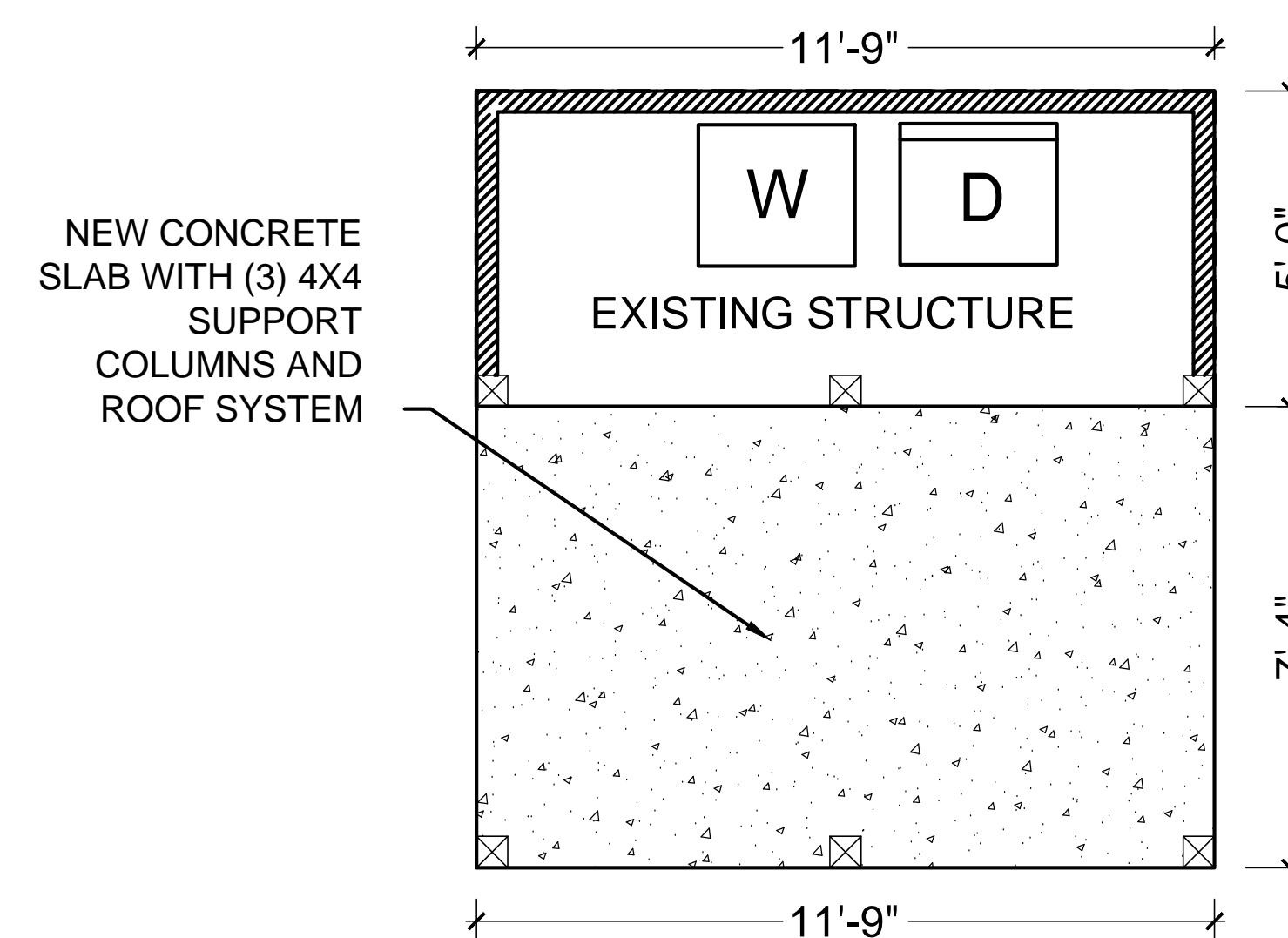

FLOOR PLAN  
3/8"=1'

SITE CALCULATIONS

BUILDING COVERAGE CALCULATIONS:

TOTAL PROPERTY IS 3556 SQ. FT.

EQUIPMENY SHED  
ORIGINAL STRUCTURE: 59 SQ. FT.  
NEW STRUCTURE: 86 SQ. FT.  
NEW TOTAL AREA: 86 SQ. FT.

STORM WATER CALCULATIONS:

LOT SIZE: 3556 SQ. FT.

EXISTING IMPERVIOUS SURFACES  
SURFACE AREA OF ENTIRE STRUCTURE: 1230 SQ. FT.  
SIDEWALK AND DECKS: 346 SQ. FT.  
POOL: 260 SQ. FT.  
EXISTING IMPERVIOUS COVERAGE: 1836 SQ. FT. OR 51.60%.

NEW IMPERVIOUS SURFACES  
SURFACE AREA OF ENTIRE STRUCTURE: 86 SQ. FT.  
NEW IMPERVIOUS COVERAGE: 1922 SQ. FT. OR 52.001%.  
INCREASE IN IMPERVIOUS COVERAGE: 86 SQ. FT.

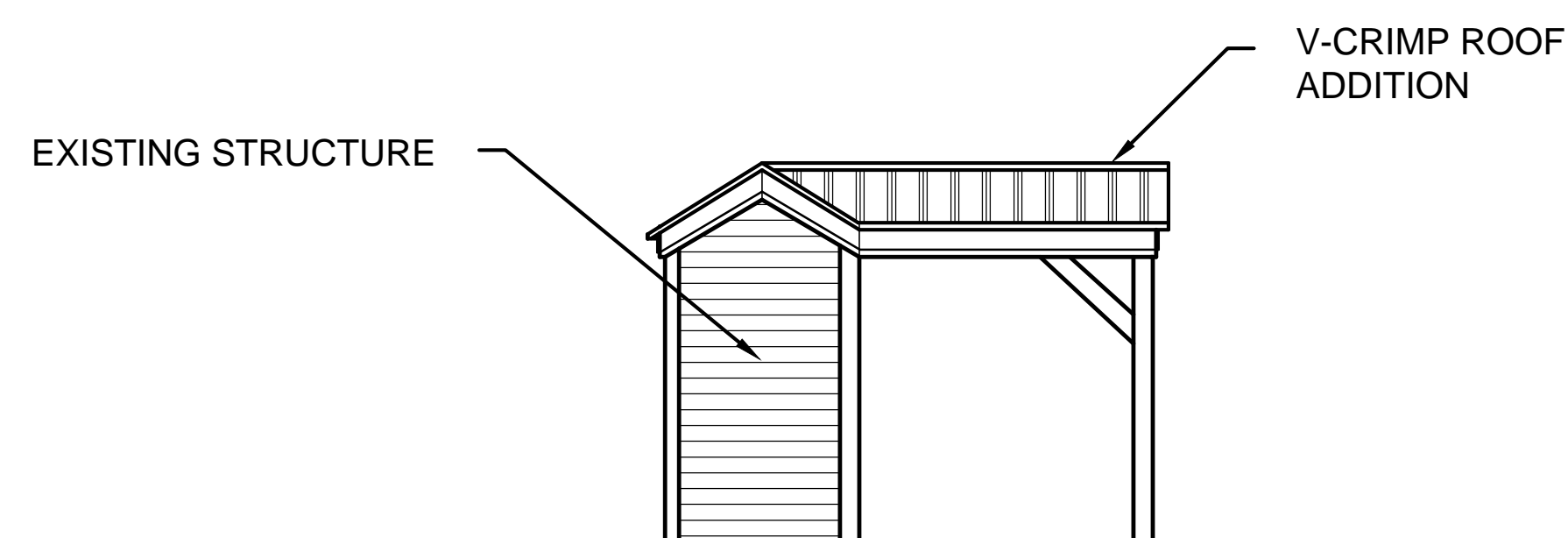

LEFT ELEVATION  
1/4"=1' RIGHT ELEVATION SIMILAR

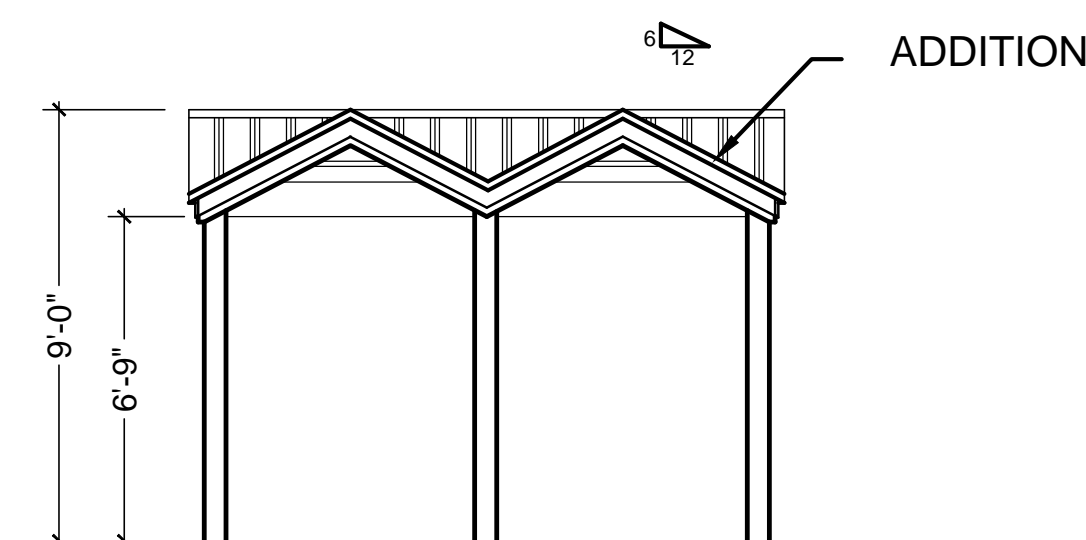

FRONT ELEVATION  
1/4"=1'

BOUNDRY SURVEY MAP LOT 7 & PART OF LOT 6, SQUARW 19  
ACCORDING TO JOHN LOWE, JR'S SUBDIVISION

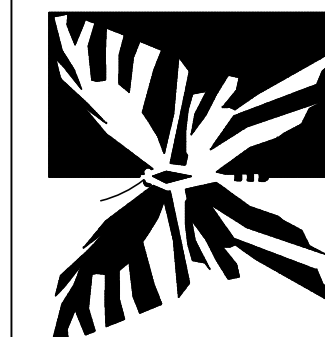

Carlos O. Rojas, AIA  
AR 0016754  
2012 Roosevelt Drive  
Key West, FL 33040  
(305) 292-4870  
ArchitectK@hotmail.com

Revisions

Carlos O. Rojas, AIA  
1016 James St  
Key West, Florida

Project Number  
2014409  
Date  
10/29/14  
Drawn By  
COR

C1



## SITE CALCULATIONS 1016 JAMES STREET

---

### IMPERVIOUS SURFACE COVERAGE CALCULATIONS:

TOTAL PROPERTY IS 3556 SQ. FT.

### EXISTING IMPERVIOUS SURFACES

SURFACE AREA OF ENTIRE STRUCTURE:	1230 SQ. FT OR 34%
SURFACE AREA OF POOL DECKS, WALKS ETC	578 SQ. FT. OR 16%.
TOTAL	1808 SQFT OR 50%

### NEW IMPERVIOUS SURFACES

INCREASE IN IMPERVIOUS COVERAGE: 86 SQ. FT.

NEW IMPERVIOUS COVERAGE: 1894 SQ. FT. OR 53%

### BUILDING COVERAGE CALCULATIONS:

TOTAL PROPERTY IS 3556 SQ. FT.

EXISTING BUILDING COVERAGE =	1230 SQFT OR 34.00%
INCREASE IN BUILDING COVERAGE:	86 SQ. FT.

NEW BUILDING COVERAGE = 1316 SQFT OR 37.00%.

# Noticing

# Public Meeting Notice

The Historic Architectural Review Commission will hold a public hearing at 5:30 p.m., November 25, 2014 at Old City Hall, 510 Greene Street, Key West, Florida. The purpose of the hearing will be to consider a request for:

**CONSTRUCTION OF NEW SCOOTER CARPORT OVER  
PARKING AREA ON THOMPSON LANE.**

**FOR- #1016 JAMES STREET**

**Applicant – Carlos Rojas, Architect**

**Application # H14-01-1750**

If you wish to see the application or have any questions, you may visit the Planning Department during regular office hours at 3140 Flagler Avenue, call 809-3973 or visit our website at [www.keywestcity.com](http://www.keywestcity.com).

**THIS NOTICE CAN NOT BE REMOVED FROM THE SITE UNTIL HARC FINAL DETERMINATION**



1016

Public  
Meeting  
Notice

# HARC POSTING AFFIDAVIT

STATE OF FLORIDA:  
COUNTY OF MONROE:

BEFORE ME, the undersigned authority, personally appeared Carlos Rojas, who, first being duly sworn, on oath, depose and says that the following statements are true and correct to the best of his/her knowledge and belief:

1. That a legal notice for Public Notice of Hearing of the Historic Architectural Review Commission (HARC) was placed on the following address: 1016 James Street on the 18 day of November, 2014.

This legal notice(s) contained an area of at least 8.5"x11".

The property was posted to notice a public hearing before the Key West Historic Architectural Review Commission to be held on NOV: 25, 2014.

The legal notice(s) is/are clearly visible from the public street adjacent to the property.

The Certificate of Appropriateness number for this legal notice is H14-01-1750.

2. A photograph of that legal notice posted in the property is attached hereto.

Signed Name of Affiant:

[Signature]  
Date: 11-18-14  
Address: 2012 Roosevelt Pr  
City: Key West  
State, Zip: FL 33040

The forgoing instrument was acknowledged before me on this 18 day of November, 2014.

By (Print name of Affiant) Carlos Rojas who is personally known to me or has produced FL DL as identification and who did take an oath.

NOTARY PUBLIC

Sign Name: [Signature]

Print Name: Petra Monson

Notary Public - State of Florida (seal)

My Commission Expires: 01/17/2017

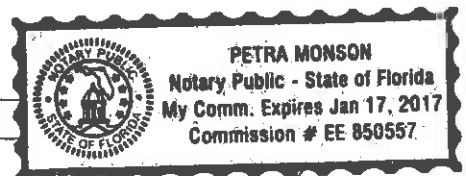

Monroe County

# **Property Appraiser Information**



**Scott P. Russell, CFA**  
**Property Appraiser**  
**Monroe County, Florida**

Key West (305) 292-3420  
Marathon (305) 289-2550  
Plantation Key (305) 852-7130

---

## Property Record Card -

**Maps are now launching the new map application version.**

**Alternate Key: 1002739 Parcel ID: 00002640-000000**

### Ownership Details

**Mailing Address:**

HYMAN BERNARD AND BARBARA  
236 ESTATES TER S  
MANHASSET, NY 11030-4066

### Property Details

**PC Code:** 01 - SINGLE FAMILY

**Millage Group:** 12KW

**Affordable Housing:** No

**Section-Township-  
Range:** 31-67-25

**Property Location:** 1016 JAMES ST KEY WEST

**Subdivision:** Corrected Diagram

**Legal Description:** KW SUB 7 PT LT 2 SQR 19 H1-323 G10-285 OR1141-143D/C OR1141-1144/45ORD OR1982-2243/45ORD  
OR1983-1566/68ORD OR2065-726 OR2520-910 OR2680-974/75

**Click Map Image to open interactive viewer**



### Land Details

Land Use Code	Frontage	Depth	Land Area
01SD - RES SUPERIOR DRY	40	80	3,404.00 SF

### Building Summary

Number of Buildings: 1  
 Number of Commercial Buildings: 0  
 Total Living Area: 988  
 Year Built: 1899



## Building 1 Details

**Building Type** R1  
**Effective Age** 7  
**Year Built** 1899  
**Functional Obs** 0

**Condition** E  
**Perimeter** 220  
**Special Arch** 0  
**Economic Obs** 0

**Quality Grade** 550  
**Depreciation %** 5  
**Grnd Floor Area** 988

**Inclusions:** R1 includes 1 3-fixture bath and 1 kitchen.

**Roof Type** GABLE/HIP

**Roof Cover** METAL

**Foundation** WD CONC PADS

**Heat 1** FCD/AIR DUCTED

**Heat 2** NONE

**Bedrooms** 3

**Heat Src 1** ELECTRIC

**Heat Src 2** NONE

**Extra Features:**

**2 Fix Bath** 0  
**3 Fix Bath** 1  
**4 Fix Bath** 0  
**5 Fix Bath** 0  
**6 Fix Bath** 0  
**7 Fix Bath** 0  
**Extra Fix** 0

**Vacuum** 0  
**Garbage Disposal** 0  
**Compactor** 0  
**Security** 0  
**Intercom** 0  
**Fireplaces** 0  
**Dishwasher** 0

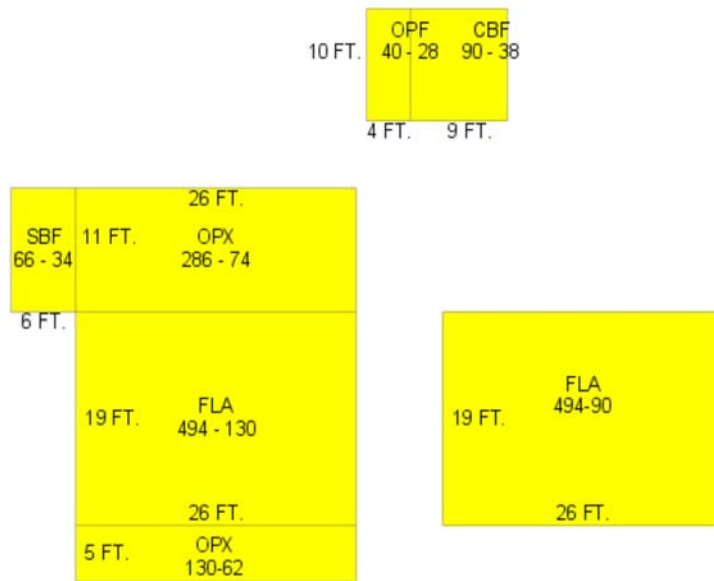

**Sections:**

Nbr	Type	Ext Wall	# Stories	Year Built	Attic A/C	Basement %	Finished Basement %	Area
0	OPX		1	2012				286
0	OPF		1	2012				40
0	CBF	1:WD FRAME/COMPOSITE	1	2012				90
0	SBF	12:ABOVE AVERAGE WOOD	1	1933				66
0	FLA	12:ABOVE AVERAGE WOOD	1	1899	Y			494

2	<u>FLA</u>	12:ABOVE AVERAGE WOOD	1	1899	N	Y	0.00	0.00	494
3	<u>OPX</u>		1	1899	N	N	0.00	0.00	130

## Misc Improvement Details

Nbr	Type	# Units	Length	Width	Year Built	Roll Year	Grade	Life
0	UB2:UTILITY BLDG	50 SF	10	5	2012	2013	3	50
0	PO4:RES POOL	162 SF	18	9	2012	2013	5	50
0	WD2:WOOD DECK	238 SF	0	0	2012	2013	2	40
0	FN2:FENCES	99 SF	33	3	2012	2013	2	30
0	FN2:FENCES	378 SF	63	6	2012	2013	2	30

## Appraiser Notes

LAND SIZE HAS INCREASED PER OR2065-726Q/C. NEIGHBOR TRANSFERRED A 204 SQUARE FOOT STRIP OF LAND TO THIS PARCEL. ADJUSTED LAND SIZE FOR THE 2005 TAX ROLL.

2005-08-29 ASKING \$899,000. 2STORY EYEBROW 4BD/1BA HAS A CISTERN AND GARAGE

2011-02-14 MLS \$325,000 4/1 DIAMOND IN THE ROUGH! TOTAL RENOVATION PROJECT AWAITING THE RIGHT PERSON TO BRING THIS GEM BACK TO IT'S GLORY. THIS FOUR BEDROOM/ONE BATH HOME HAS A NICE SIZED BACK YARD THAT WOULD ACCOMODATE A POOL AND NICE GARDENS. PROPERTY CAN BE ACCESSED THROUGH THOMPSON LANE.

## Building Permits

Bldg Number	Date Issued	Date Completed	Amount	Description	Notes
1	12-0579	02/21/2012	10/11/2012	20,000	9 x 19 POOL
1	11-4294	01/29/2011	10/11/2012	125,000	RENOVATION OF A EYEBROW HOUSE
1	11-4292	11/23/2011	10/01/2012	0	DEMOLITION OF SELECTIVE FIRST FLR
1	11-4732	01/03/2012	10/11/2012	8,180	1 WASHER, 1 D/W, 1 KITCH SINK, 2 LAVS, 2 SHOWERS, 2 TOILETS,
1	12-0955	03/15/2012	10/11/2012	8,500	WIRE HOUSE PER PLANS
1	12-1327	04/17/2012	10/11/2012	6,000	INSTALL 3 TON AC DUCTWORK INCLUDED
1	12-0920	03/15/2012	10/11/2012	12,491	INSTALL 900sf VICTORIAN METAL SHINGLES ON MAIN ROOF, 400sf ON REFURBISHED REAR
1	12-3654	10/04/2012	04/23/2013	1,900 Residential	OPEN PICKET FENCE 4' AT FRONT OF PROPERTY. SEE ATTACHED PLANS. OPEN PICKETS, PAINT WHITE.
1	13-0970	04/17/2013	04/23/2013	1,900 Residential	FRONT DOOR, 4 REAR DOORS CLASS A DADE COUNTY APPROVED AND WIND LOAD RATED ALUM. HURRICANE PANELS.
1	9702682	08/01/1997	12/01/1997	1,800	ELECTRICAL

## Parcel Value History

Certified Roll Values.

[View Taxes for this Parcel.](#)

Roll Year	Total Bldg Value	Total Misc Improvement Value	Total Land Value	Total Just (Market) Value	Total Assessed Value	School Exempt Value	School Taxable Value
-----------	------------------	------------------------------	------------------	---------------------------	----------------------	---------------------	----------------------

2014	181,462	21,705	679,131	882,298	368,754	0	882,298
2013	183,352	22,167	567,930	773,449	335,231	0	773,449
2012	16,659	0	259,981	276,640	276,640	0	276,640
2011	29,307	2,346	252,996	284,649	284,648	25,000	259,649
2010	71,587	2,346	316,742	390,675	387,900	25,000	362,901
2009	102,100	2,346	481,448	375,000	375,000	25,000	350,000
2008	92,819	2,346	536,130	631,295	567,051	25,000	542,051
2007	159,843	2,190	454,434	616,467	552,315	25,000	527,315
2006	305,542	2,190	323,380	631,112	553,684	25,000	528,684
2005	242,494	2,190	292,744	537,428	499,906	25,000	474,906
2004	206,725	2,190	240,000	448,915	448,915	25,000	423,915
2003	164,441	2,190	118,400	285,031	181,550	25,500	156,050
2002	156,113	2,190	86,400	244,703	160,471	25,500	134,971
2001	140,502	2,263	86,400	229,165	152,102	25,500	126,602
2000	106,381	3,411	64,800	174,592	123,723	25,500	98,223
1999	96,191	3,224	64,800	164,215	117,577	25,500	92,077
1998	77,442	2,706	64,800	144,948	115,726	25,000	90,726
1997	73,366	2,635	58,400	134,401	113,792	25,000	88,792
1996	55,025	2,055	58,400	115,479	110,478	25,000	85,478
1995	50,134	1,870	58,400	110,403	107,784	25,000	82,784
1994	44,835	1,716	58,400	104,951	104,951	25,000	79,951
1993	42,804	296	58,400	101,500	101,500	25,000	76,500
1992	42,804	296	58,400	101,500	101,500	25,000	76,500
1991	42,804	296	58,400	101,500	101,500	25,000	76,500
1990	36,705	296	39,200	76,201	76,201	25,500	50,701
1989	30,335	269	41,600	72,204	72,204	25,500	46,704
1988	26,446	269	32,000	58,715	58,715	25,500	33,215
1987	26,132	269	17,880	44,281	44,281	25,500	18,781
1986	26,274	269	17,280	43,823	43,823	25,500	18,323
1985	25,489	269	10,400	36,158	36,158	25,500	10,658
1984	23,709	269	10,400	34,378	34,378	25,500	8,878
1983	23,709	269	10,400	34,378	34,378	25,500	8,878
1982	24,190	269	10,400	34,859	34,859	25,500	9,359

## Parcel Sales History

NOTE: Sales do not generally show up in our computer system until about two to three months after the date of sale. If a recent sale does not show up in this list, please allow more time for the sale record to be processed. Thank you for your patience and understanding.

Sale Date	Official Records Book/Page	Price	Instrument	Qualification
4/15/2014	2680 / 974	895,000	<u>WD</u>	<u>02</u>
6/2/2011	2520 / 910	275,000	<u>WD</u>	<u>03</u>

This page has been visited 48,388 times.

Monroe County Monroe County Property Appraiser  
Scott P. Russell, CFA  
P.O. Box 1176 Key West, FL 33041-1176