

Notice to Bidder: Use Black Ink or Type For Completing the Form.

BID

To: The City of Key West
Address: 3126 Flagler Ave, Key West, Florida 33040
Project Title: FIRE STATION DOOR REPLACEMENT
Project: ITB #14-004

BIDDER'S INFORMATION

Name: MINGO AND COMPANY, LLC
Address: 5580 1ST AVE.
KEY WEST, FL 33040
Contact Name: DOMINGO CASTELLANOS
Email: mingo@mingoandco LLC.com
Telephone: 305-293-0442
Fax: 305-293-0443

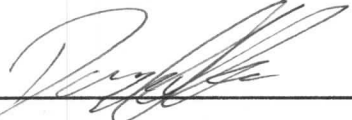
Signature:  **Date:** 5/14/2014

BIDDER'S DECLARATION AND UNDERSTANDING

The undersigned, hereinafter called the Bidder, declares that the only persons or parties interested in this Bid are those named herein, that this Bid is, in all respects, fair and without fraud, that it is made without collusion with any official of the Owner, and that the Bid is made without any connection or collusion with any person submitting another Bid on this Contract.

The Bidder further declares that he/she has carefully examined the Contract Documents for the construction of the project, that he/she has personally inspected the site, that he/she has satisfied himself/herself as to the quantities involved, including materials and equipment, and conditions of work involved, including the fact that the description of the quantities of work and materials, as included herein, is brief and is intended only to indicate the general nature of the work and to identify the said quantities with the detailed requirements of the Contract Documents, and that

this Bid is made according to the provisions and under the terms of the Contract Documents, which Documents are hereby made a part of this Bid.

The Bidder further agrees that he/she has exercised his/her own judgment regarding the interpretation of job conditions and has utilized all data, which he/she believes pertinent from the Project Manager, Owner, and other sources in arriving at his/her conclusions.

The intent of the Bid Documents is to describe a functionally complete project (or part thereof) to be constructed in accordance with the Contract Documents. Any work, materials, or equipment that may reasonably be inferred from the Contract Documents, as being required to produce the intended result shall be supplied whether or not specifically called for.

CONTRACT EXECUTION AND BONDS

The Bidder agrees that if this BID is accepted, he/she will, within ten (10) calendar days after Notice of Award, sign the Contract in the form annexed hereto, will attach all required licenses and certificates, and will, to the extent of his BID, furnish all equipment, materials, and labor necessary to complete all work as specified or indicated in the Contract Documents. Performance and Payment Bonds in an amount equal to 100% of contract value will be required as part of this contract.

CERTIFICATES OF INSURANCE

Bidder agrees to furnish the Owner, before commencing the work under this Contract, the certificates of insurance as specified in these Documents.

START OF CONSTRUCTION AND CONTRACT COMPLETION TIME

The Bidder further agrees to begin work within twenty (20) calendar days after the date of the Notice to Proceed and to complete the construction of all items in the lump sum base Bid, in all respects, for this particular project, within ninety (90) calendar days after the date of the Notice to Proceed.

LIQUIDATED DAMAGES

In the event the Bidder is awarded the Contract and shall fail to complete the work within the time limit or extended time limit agreed upon as more particularly set forth in the Contract Documents, liquidated damages shall be paid to the Owner at the rate of five hundred dollars (\$500.00) per day for all work awarded under this contract until the work has been satisfactorily completed as provided by the Contract Documents. Sundays and legal holidays shall be included in determining days in default.

ADDENDA

The Bidder hereby acknowledges that he has received Addenda No's. 1
 (Bidder shall insert No. of each Addendum received) and agrees that all addenda issued



THE CITY OF KEY WEST

Post Office Box 1409
Key West, FL 33041-1409

ADDENDUM NO. 1 – FIRE STATION DOOR REPLACEMENT/ ITB 14-004

This addendum is issued as supplemental information to the bid package for clarification of certain matters of both a general and a technical nature. The referenced bid package is hereby addended in accordance with the following items:

RFI Questions Submitted

I. Should all operations of doors, such as openers, electrical low voltage, and emergency shut offs be included?

Yes, as stated in the "Invitation to Bid", page 6, The project contemplates consists of providing all materials, equipment and labor necessary

II. There's no preferred manufacture for doors so we are assuming the proposal should include manufacture specs, engineering, and sealed drawings correct?

Yes , as stated in the "Scope of Work" , page 85.

III. This project is small but is the local vendors or contractors advantage to hire local part of this bid submission.

Yes, as sated on page 50, # 14 a. "Local Preference" of the bid documents.

IV. The time frame of 90 days may be dependent on manufacturing by door supplier. Some have 6-8 week lead times. Something we should include in contract docs.

Please submit a work schedule with your bid including manufacturers lead time.

All Bidders shall acknowledge receipt and acceptance of this Addendum No. 1 by submitting the addendum with their proposal. Proposals submitted without acknowledgement or without this Addendum may be considered non-responsive.

Signature

MINGO AND COMPANY, LLC
Name of Business

BID FORM

ITB #14-004: FIRE STATION DOOR REPLACEMENT

FIRE STATION # 1 @ 1600 NORTH ROOSEVELT BOULEVARD

LUMP SUM BASE BID PRICE for SIX (6) ROLL-UP DOORS 12' w x 16' h
(MEASUREMENTS TO BE VERIFIED BY BIDDER)

\$ 61,912.00

SIXTY-ONE THOUSAND NINE HUNDRED TWELVE AND NO CENTS
Bid Total in Words

BID ALTERNATIVES FOR FIRE STATION #1

ALTERNATE 1 for SIX (6) OVERHEAD DOORS

\$ 58,320.00

FIFTY EIGHT THOUSAND THREE HUNDRED TWENTY AND NO CENTS
Bid Total in Words

ALTERNATE 2 for SIX (6) BI-FOLD DOORS

\$ N/A

N/A
Bid Total in Words

***ALL BIDS INCLUDE REMOVAL & DISPOSAL of ALL ELEMENTS of EXISTING DOORS**

FIRE STATION # 3 @ 1525 KENNEDY DRIVE

**LUMP SUM BASE BID PRICE for THREE (3) ROLL-UP DOORS 12'w x 12' h
(MEASUREMENTS TO BE VERIFIED BY BIDDER)**

\$ 39,960.00

THIRTY-NINE THOUSAND NINE HUNDRED SIXTY AND NO CENTS

Bid Total in Words

BID ALTERNATIVES FOR FIRE STATION #3

ALTERNATE 1 for THREE (3) OVERHEAD DOORS

\$ 36,325.00

THIRTY-SIX THOUSAND THREE HUNDRED TWENTY-FIVE AND NO CENTS

Bid Total in Words

ALTERNATE 2 for THREE (3) BI-FOLD DOORS

\$ N/A

N/A
Bid Total in Words

***ALL BIDS INCLUDE REMOVAL & DISPOSAL of ALL ELEMENTS of EXISTING DOORS**

BID BREAKDOWN*

The Bidder shall provide a Schedule of Values for all aspects of the project including mobilization/demobilization, labor and materials, permitting, etc. required or to be used for the project. The schedule of values shall be in sufficient detail to allow the owner to understand how the Bidder arrived at said Base Bid and Alternate Bid prices and shall become part of the contract for basis of payment. The City may ask for a more detailed schedule of values if one submitted is not sufficient.

***FINAL PAYMENT WILL BE BASED ON ACTUAL QUANTITIES MEASURED IN THE FIELD AND APPROVED BY CITY STAFF**

SUBCONTRACTORS

The Bidder further proposes that the following subcontracting firms or businesses will be awarded subcontracts for the following portions of the work in the event that the Bidder is awarded the Contract:

Portion of Work: SUPPLY DOORS AND INSTALLATION

Name: ROLLING DOOR MANUFACTURING

Address: 8214 N.W. 64ST. MIAMI, FL 33166

Portion of Work: ELECTRICAL SERVICES

Name: FLORIDA KEYS ELECTRIC

Address: 5730 2ND AVE KEY WEST, FL 33040

Portion of Work: _____

Name: _____

Address: _____

BIDDER

The name of the Bidder submitting this Bid is: MINGO AND COMPANY, LLC

Doing business at 5580 1ST AVE.

City KEY WEST State FL Zip 33040

Telephone No. 305-293-0442

This address is where all communications concerning this Bid shall be sent.

The names of the principal officers of the Corporation submitting this Bid, or of the Partnership, or of all persons interested in this Bid as Principals are as follows:

Name	Title
<u>DOMINGO CASTELLANOS</u>	<u>OWNER</u>

If Corporation

IN WITNESS WHEREOF the undersigned corporation has caused this instrument to be executed and its seal affixed by its duly authorized officers this 14TH day of MAY, 2014.

(SEAL)

Name of Corporation

By: [Signature]

Title: OWNER

Attest: [Signature]

Secretary

If Sole Proprietor or Partnership

IN WITNESS hereto the undersigned has set his/her/its hand this _____ day of _____, 2014.

Signature of Bidder _____

Title _____

**SWORN STATEMENT UNDER SECTION 287.133(3)(a)
FLORIDA STATUTES, ON PUBLIC ENTITY CRIMES**

PROJECT ITB #14-004:FIRE STATION DOOR REPLACEMENT

**THIS FORM MUST BE SIGNED IN THE PRESENCE OF A NOTARY PUBLIC OR OTHER OFFICE
AUTHORIZED TO ADMINISTER OATHS.**

1. This sworn statement is submitted with Bid, Bid or Contract No. 14-004 for
FIRE STATION DOOR REPLACEMENT

2. This sworn statement is submitted by MINGO AND COMPANY, LLC
(Name of entity submitting sworn statement)

whose business address is 5580 1ST AVE. KEY WEST, FL 33040
and (if applicable) its Federal
Employer Identification Number (FEIN) is 20-4529951 (If the entity has no FEIN,
include the Social Security Number of the individual signing this sworn statement.)

3. My name is DOMINGO CASTELLANOS and my relationship to
(Please print name of individual signing)

the entity named above is OWNER.

4. I understand that a "public entity crime" as defined in Paragraph 287.133(1)(g), Florida Statutes, means a violation of any state or federal law by a person with respect to and directly related to the transaction of business with any public entity or with an agency or political subdivision of any other state or with the United States, including but not limited to, any Bid or contract for goods or services to be provided to any public entity or an agency or political subdivision of any other state or of the United States and involving antitrust, fraud, theft, bribery, collusion, racketeering, conspiracy, material misrepresentation.

5. I understand that "convicted" or "conviction" as defined in Paragraph 287.133(1)(b), Florida Statutes, means a finding of guilt or a conviction of a public entity crime, with or without an adjudication of guilt, in any federal or state trial court of record relating to charges brought by indictment information after July 1, 1989, as a result of a jury verdict, nonjury trial, or entry of a plea of guilty or nolo contendere.

6. I understand that an "affiliate" as defined in Paragraph 287.133(1)(a), Florida Statutes, means

1. A predecessor or successor of a person convicted of a public entity crime: or

2. An entity under the control of any natural person who is active in the management of the entity and who has been convicted of a public entity crime. The term "affiliate" includes those officers, directors, executives, partners, shareholders, employees, members, and agents who are active in the management of an affiliate. The ownership by one person of shares constituting controlling interest in another person, or a pooling of equipment or income among persons when not for fair market value under an arm's length agreement, shall be a prima facie case that one person controls another person. A person who knowingly enters into a joint venture with a person who has been convicted of a public entity crime in Florida during the preceding 36 months shall be considered an affiliate.

7. I understand that a "person" as defined in Paragraph 287.133(1)(8), Florida Statutes, means any natural

person or entity organized under the laws of any state or of the United States with the legal power to enter into a binding contract and which Bids or applies to Bid on contracts for the provision of goods or services let by a public entity, or which otherwise transacts or applies to transact business with a public entity. The term "person" includes those officers, directors, executives, partners, shareholders, employees, members, and agents who are active in management of an entity.

8. Based on information and belief, the statement, which I have marked below, is true in relation to the entity submitting this sworn statement. (Please indicate which statement applies.)

Neither the entity submitting this sworn statement, nor any officers, directors, executives, partners, shareholders, employees, members, or agents who are active in management of the entity, nor any affiliate of the entity have been charged with and convicted of a public entity crime subsequent to July 1, 1989.

The entity submitting this sworn statement, or one or more of the officers, directors, executives, partners, shareholders, employees, members, or agents who are active in management of the entity, or an affiliate of the entity has been charged with and convicted of a public entity crime subsequent to July 1, 1989, AND (Please indicate which additional statement applies.)

There has been a proceeding concerning the conviction before a hearing of the State of Florida, Division of Administrative Hearings. The final order entered by the hearing officer did not place the person or affiliate on the convicted vendor list. (Please attach a copy of the final order.)

The person or affiliate was placed on the convicted vendor list. There has been a subsequent proceeding before a hearing officer of the State of Florida, Division of Administrative Hearings. The final order entered by the hearing officer determined that it was in the public interest to remove the person or affiliate from the convicted vendor list. (Please attach a copy of the final order.)

The person or affiliate has not been put on the convicted vendor list. (Please describe any action taken by or pending with the Department of General Services.)

[Signature]
(Signature)

5-14-14
(Date)

STATE OF FLORIDA

COUNTY OF MONROE

PERSONALLY APPEARED BEFORE ME, the undersigned authority,

Domingo Castellanos who, after first being sworn by me, affixed his/her signature in the
(Name of individual signing)

space provided above on this 14 day of May, 2014.

My commission expires:

[Signature]
NOTARY PUBLIC

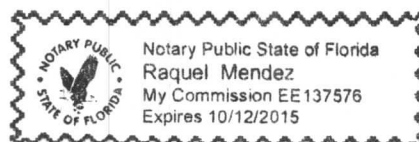

ANTI-KICKBACK AFFIDAVIT

PROJECT ITB #14-004: FIRE STATION DOOR REPLACEMENT

STATE OF FLORIDA)
: SS
COUNTY OF MONROE)

I, the undersigned hereby duly sworn, depose and say that no portion of the sum herein Bid will be paid to any employees of the City of Key West as a commission, kickback, reward or gift, directly or indirectly by me or any member of my firm or by an officer of the corporation.

By: 

Sworn and subscribed before me this

14 day of MAY, 2014.

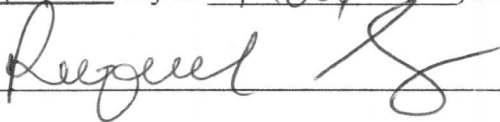

NOTARY PUBLIC, State of FL at Large

My Commission Expires: 10/12/2015

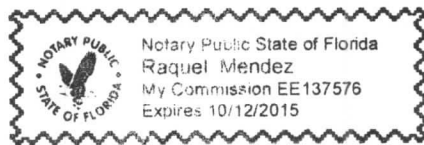

CITY OF KEY WEST INDEMNIFICATION FORM

To the fullest extent permitted by law, the Contractor expressly agrees to indemnify and hold harmless the City of Key West, their officers, directors, agents, and employees (herein called the "indemnities") from liabilities, damages, losses and costs, including, but not limited to, reasonable attorney's fees and court costs, such legal expenses to include costs incurred in establishing the indemnification and other rights agreed to in this Paragraph, to persons or property, to the extent caused by the negligence, recklessness, or intentional wrongful misconduct of the Contractor its Subcontractors or persons employed or utilized by them in the performance of the Contract. Claims by indemnities for indemnification shall be limited to the amount of Contractor's insurance or \$1 million per occurrence, whichever is greater. The parties acknowledge that the amount of the indemnity required hereunder bears a reasonable commercial relationship to the Contract and it is part of the project specifications or the bid documents, if any.

The indemnification obligations under the Contract shall not be restricted in any way by any limitation on the amount or type of damages, compensation, or benefits payable by or for the Contractor under workers' compensation acts, disability benefits acts, or other employee benefits acts, and shall extend to and include any actions brought by or in the name of any employee of the Contractor or of any third party to whom Contractor may subcontract a part or all of the Work. This indemnification shall continue beyond the date of completion of the work.

CONTRACTOR: MINGO AND COMPANY, LLC

SEAL:

5580 1ST AVE, KEYWEST, FL 33040

Address



Signature

DOMINGO CASTELLANOS

Print Name

OWNER

Title

5/14/2014

Date

**LOCAL VENDOR CERTIFICATION PURSUANT TO CKW ORDINANCE 09-22
SECTION 2-798
PROJECT ITB #14-004: FIRE STATION DOOR REPLACEMENT**

The undersigned, as a duly authorized representative of the vendor listed herein, certifies to the best of his/her knowledge and belief, that the vendor meets the definition of a "Local Business." For purposes of this section, "local business" shall mean a business which:

- a. Principle address as registered with the FL Department of State located within 30 miles of the boundaries of the city, listed with the chief licensing official as having a business tax receipt with its principle address within 30 miles of the boundaries of the city for at least one year immediately prior to the issuance of the solicitation.
- b. Maintains a workforce of at least 50 percent of its employees from the city or within 30 miles of its boundaries.
- c. Having paid all current license taxes and any other fees due the city at least 24 hours prior to the publication of the call for bids or request for proposals.
 - Not a local vendor pursuant to Ordinance 09-22 Section 2-798
 - Qualifies as a local vendor pursuant to Ordinance 09-22 Section 2-798

If you qualify, please complete the following in support of the self certification & submit copies of your County and City business licenses. Failure to provide the information requested will result in denial of certification as a local business.

Business Name MINGO AND COMPANY, LLC Phone: 305-293-0442

Current Local Address: 5580 1ST AVE KEY WEST, FL 33040 Fax: 305-293-0443
(P.O Box numbers may not be used to establish status)

Length of time at this address: 9 MONTHS

[Signature] Date: 5-14-14
Signature of Authorized Representative

STATE OF FLORIDA COUNTY OF MONROE

The foregoing instrument was acknowledged before me this 14 day of May, 2014.

By Domingo Castellanos, of Mingo and Company
(Name of officer or agent, title of officer or agent) (Name of corporation acknowledging)

or has produced _____ as identification
(Type of identification)

[Signature]
Signature of Notary
Notary Public State of Florida
Raquel Mendez
My Commission EE 137578
Print Name or Stamp Name of Notary
Asst Branch Manager
Title or Rank

Return Completed form with
Supporting documents to:
City of Key West Purchasing

CONE OF SILENCE AFFIDAVIT

STATE OF FLORIDA)
 : SS
COUNTY OF MONROE)

I the undersigned hereby duly sworn depose and say that all owner(s), partners, officers, directors, employees and agents representing the firm of MINGO AND COMPANY, LLC have read and understand the limitations and procedures regarding communications concerning City of Key West issued competitive solicitations pursuant to City of Key West Ordinance Section 2-773 Cone of Silence (attached).

Sworn and subscribed before me this

14 day of MAY, 2014.

Roseanne J

NOTARY PUBLIC, State of FL at Large

My Commission Expires: 10/12/2015

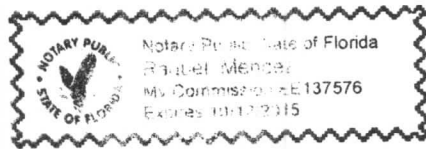

MINGO

& COMPANY LLC

2819 STAPLES AVE, KEY WEST, FLORIDA 33040 • OFFICE: 305.293.0442 • FAX: 305.293.0443

5/14/2014

Mingo and Company, LLC does not have any previous or existing legal action against said company within the past three (3) years.

Attested By:

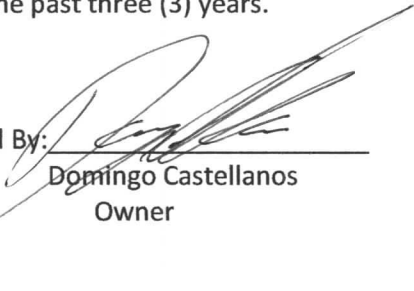

Domingo Castellanos
Owner

MINGO

& COMPANY LLC

2819 STAPLES AVE, KEY WEST, FLORIDA 33040 • OFFICE: 305.293.0442 • FAX: 305.293.0443

SCHEDULE OF WORK

Permitting and Shop Drawings for Doors – Two Weeks

Manufacturing of Doors – Four Weeks

Delivery of Doors – One Week

Demo and Installation of Doors Including Electrical – Three Weeks

Inspection and Sign Off – One Week

MINGO

& COMPANY LLC

2819 STAPLES AVE, KEY WEST, FLORIDA 33040 • OFFICE: 305.293.0442 • FAX: 305.293.0443

References

Southernmost Beach Motel Limited Partnership

121 W. Long Lake Road

Bloomfield Hills, MI 48304

Mr. Stuart Kaufman

248-568-6643

Project: Simonton & Duval Buildings 6/2012 – 10/2012

Conch Harbor Marina

951 Caroline Street

Key West, FL 33040

Mr. Craig Hunt

305-294-2933

Project: West Marine Store 2/2013 – 8/2013

BurgerFi International, LLC

105 US Highway 1

North Palm Beach, FL 33408

Ms. Sandy Karp

561-844-5528

Project: 221 Duval Street 4/2013 – 7/2013

See attached letters

Southernmost Beach Motel Limited Partnership

121 W. Long Lake Rd.
Suite 310
Bloomfield Hills, Mi. 48304

November 16, 2013

To Whom It May Concern:

As managing member of Southernmost Beach Motel Limited Partnership, The former owner and operator of the Southernmost Hotel Collection we have, over the last several years, used Mingo Castellanos exclusively for all our construction projects at the hotel. We have use Mingo exclusively because he consistently finished on time and on budget, and finishing on time in our business, where every day a room is out of service represents revenue that can't be recouped, is critically important. Equally importantly, the quality of Mingo's work always met our high standards and when unexpected field conditions arose Mingo was very resourceful un coming up with a good fix or work around to keep the job moving without sacrificing quality.

The work done by Mingo over the years ranged from simple bathroom remodels to complete renovations of entire buildings including correcting structural issues and building all new rooms.



Stuart Kaufman



January 17, 2014

Mr. Domingo Castellanos
Mingo & Company
5580 1st Ave.
Key West, FL 33040

Dear Mingo,

I would like to offer my appreciation for a job well done. The new 13,500 sq ft commercial space that you have constructed for us shows an excellent quality of work. I was impressed that you were able to meet our tight time frame. I truly believe that the communication level that was kept during the construction process was paramount. The weekly meetings with the sub contractors and your team were essential to us being informed every step of the way. I am certain that anyone else you work with in the future will be pleased with you and your team.

Sincerely,



Craig Hunt



LETTER OF RECOMMENDATION

December 14, 2014

To whom it may concern:

It is my pleasure to write this unsolicited letter of recommendation on behalf of Domingo "Mingo" Castellanos and the Mingo Construction Team. Mingo was the general contractor for a remodeling project for BurgerFi International located at 221 Duval Street. I had no prior relationship with Mingo, who was recommended by the Landlord's Attorney and the Landlord. The scope of the work was to be contracted as a Design/Build.

While major remodeling of a historic building is stressful in itself, Mingo's services as a general contractor were invaluable, and I am extremely pleased with the final result. Specifically, I would give Mingo top marks in the following areas:

1. Quality of work performed.
2. Quality of work crews. The workmen whom Mingo utilized were professional, reliable, courteous, and respectful of our schedule. They had an old school work ethic (often 10-hour days, 7 days per week). Their pride in their work was evident. I also found them to be trustworthy.
3. Project management and coordination. Bob's prior experience working in construction really paid off. His excellent attention to detail, strong organizational skills and commitment to follow-through are assets which enabled him to juggle the extensive details involved in our project without missing a beat. Mingo's familiarity with building codes and dealing with city hall also facilitated a smooth and process when it came to building permits and inspections.

In closing, I most definitely recommend Mingo Construction for any project in the Keys and would use them again if I am ever building in this area again.

Sincerely,

Sandy Karp

Sandy Karp
Director of Construction
BurgerFi International LLC

BurgerFi® International, LLC
105 US Highway 1
North Palm Beach, Florida 33408
(561)844-5528

AC# 6120539

STATE OF FLORIDA

DEPARTMENT OF BUSINESS AND PROFESSIONAL REGULATION
CONSTRUCTION INDUSTRY LICENSING BOARD

SEQ# L12050700928

DATE	BATCH NUMBER	LICENSE NBR
05/07/2012	110373111	CGC1520559

The GENERAL CONTRACTOR
Named below IS CERTIFIED
Under the provisions of Chapter 489 FS.
Expiration date: AUG 31, 2014

CASTELLANOS, DOMINGO G
MINGO & COMPANY LLC
2819 STAPLES AVENUE
KEY WEST FL 33040

RICK SCOTT
GOVERNOR

KEN LAWSON
SECRETARY

DISPLAY AS REQUIRED BY LAW

CITY OF KEY WEST, FLORIDA

Business Tax Receipt

This Document is a business tax receipt
Holder must meet all City zoning and use provisions.
P.O. Box 1409, Key West, Florida 33040 (305) 809-3955

Business Name MINGO & COMPANY LLC CtlNbr:0016524
Location Addr 5580 1ST AVE
Lic NBR/Class 14-00020184 CONTRACTOR - CERT GENERAL CONTRACTOR
Issue Date: September 24, 2013 Expiration Date: September 30, 2014
License Fee \$309.75
Add. Charges \$0.00
Penalty \$0.00
Total \$0.00

Comments:

This document must be prominently displayed.
MINGO & COMPANY LLC

MINGO & COMPANY LLC
2819 STAPLES AVE

KEY WEST FL 33040



**ROLLING DOOR
MANUFACTURING**

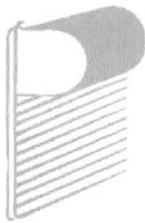

Rolling Overhead Doors

A proven performer that provides quality and security, our overhead doors create a high strength barrier, showcase your property and discourage forced entry.

Rolling Door Manufacturing is a leading provider of door solutions for any application. This door provides a great value and a fast return on your investment, with low maintenance costs and a smooth operation.

Our line of Rolling Doors come with:

- One Year Warranty.
- High Strength 22 Gauge Galvanized Steel with a Baked on White Finish for Extra Protection.

Our rolling door is laboratory tested and approved by the State of Florida to withstand hurricane winds of up to 150 MPH (3-sec gusts) and missile impacts with a pressure rating of 65 pounds per sq. foot (PSF).



**Product Approval No.
FL 14444
(For High Velocity
Hurricane Zones)**

Benefits:

- Unclutter your space! This door has been designed to make the most out of the available space. The curtain rolls into a compact box at the top, creating extra space and providing a clean look.
- Lower your maintenance costs! the parts are built for a heavy duty use and are tested to perform in the toughest environments.
- Protect your place from mother nature! Our High Velocity doors are tested to perform to their rated windspeed and pressure by an independent engineering firm.
- Capable of withstanding hurricane force winds and object impact.
- Available for custom wind load designs.
- Provides reliable protection against robbery and vandalism.



- Heavy Duty Rolling Door installed with motor operation in the NOAA Headquarters in Miami, Florida.



Our Rolling Doors offer heavy duty protection but maintain a compact design that works great in reduced spaces.



Our Rolling Doors are offered in a custom design for residential applications, we give the customer a range of options to choose from to enhance their home.

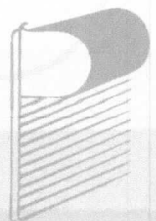

The Fire Station No. 6 in the City of Hialeah installed Stormproof rolling doors for their renovation improvements in 2009.



Components

Hood

Protective sheet metal (24 gauge steel galvanized) enclosure for the curtain. Enclosure is hexagonal or square depending on door dimensions.

Counterbalance Shaft

Supports curtain and contains counterbalance torsion springs for assisting operation. High-cycle torsion spring designs available for special uses.

Brackets

Holds the counterbalance shaft and the chain/motor mechanisms for door operation. 3/16" or 1/4" steel plates to support hood and torsion springs.

Guides

The guides are railings on which the curtain rolls up and down. Structural Steel Galvanized Angles of 3/16" guides that support entire door weight.

Curtain

The curtain has a series of interconnected 20 gauge or 22 gauge steel galvanized flat slats fitted with windlocks. Optional finish: Range of Dura-Color powdercoat finishes and a white/brown standard finish.

Bottom Bar

The lower part of the curtain that holds the locking mechanisms. Two steel galvanized angles with a weather-proof strip for protection.

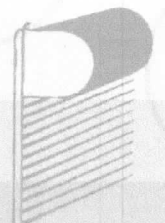

Operation:

Features and Accesories

Chain Hoist

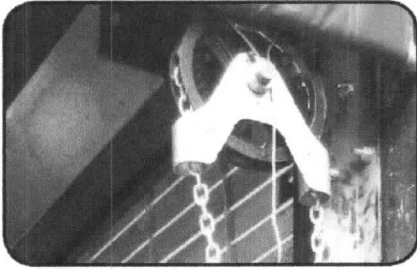

Central Electric Motor

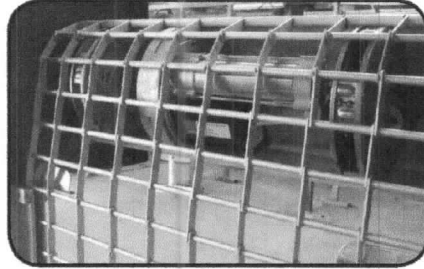

Electric Motor

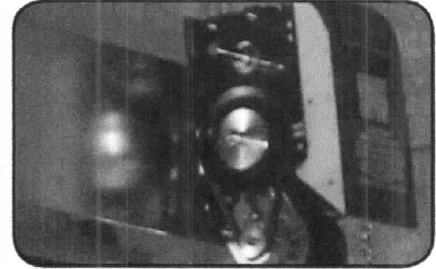

Locking Mechanisms:

Round Locks

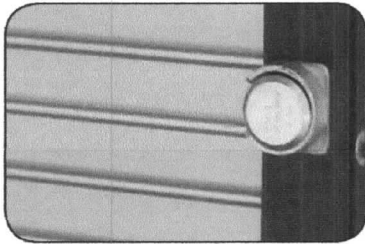

Central Locks

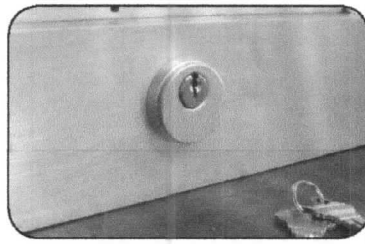

Slide Locks

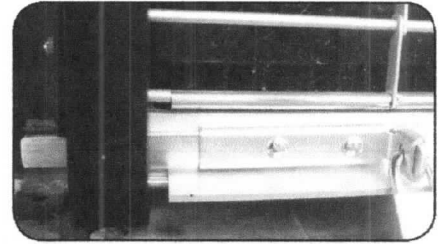

Accessories for motor operated rolling doors:

- A. Key switch
- B. Push button station
- C. Remote control units
- D. Photocells

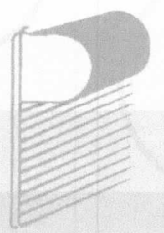
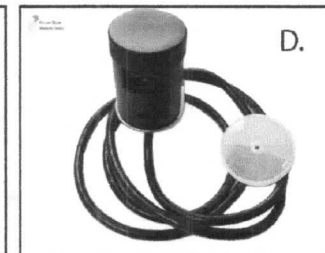
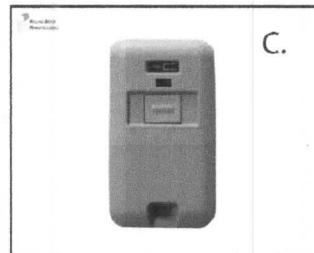
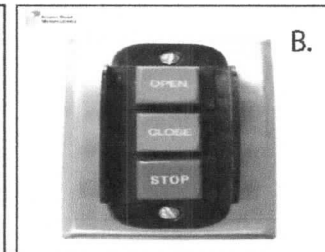
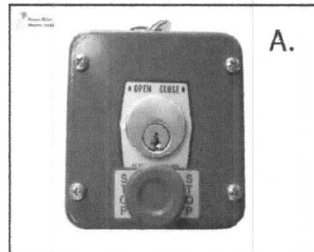



Product Approval
USER: Public User

License efficiently. Regulate fairly.

[Product Approval Menu](#) > [Product or Application Search](#) > [Application List](#) > **Application Detail**

OFFICE OF THE SECRETARY

FL #	FL14444-R1	
Application Type	Revision	
Code Version	2010	
Application Status	Approved	
Comments		
Archived		
Product Manufacturer	Rolling Door Industries, LLC	
Address/Phone/Email	8214 NW 64th St Miami, FL 33166 (305) 599-9977 mail@rolling-door.com	
Authorized Signature	Ernesto Rodriguez mail@rolling-door.com	
Technical Representative		
Address/Phone/Email		
Quality Assurance Representative		
Address/Phone/Email		
Category	Exterior Doors	
Subcategory	Roll-Up Exterior Door Assemblies	
Compliance Method	Evaluation Report from a Florida Registered Architect or a Licensed Florida Professional Engineer Evaluation Report - Hardcopy Received	
Florida Engineer or Architect Name who developed the Evaluation Report	Walter A. Tillit Jr., P.E.	
Florida License	PE-44167	
Quality Assurance Entity	National Accreditation and Management Institute	
Quality Assurance Contract Expiration Date	12/31/2014	
Validated By	Vladimir Knezevich Validation Checklist - Hardcopy Received	
Certificate of Independence	FL14444_R1_COI_Certificate_of_Independence_Drwg_11-233.pdf FL14444_R1_COI_Certification_of_Independence_Drwg_11-234.pdf FL14444_R1_COI_Certification_of_Independence_Drwg_11-249.pdf	
Referenced Standard and Year (of Standard)	Standard TAS 201, 202 and 203	Year 1994
Equivalence of Product Standards Certified By		
Sections from the Code		
Product Approval Method	Method 1 Option D	
Date Submitted	12/19/2011	
Date Validated	12/20/2011	
Date Pending FBC Approval	01/03/2012	
Date Approved	01/31/2012	

Summary of Products

FL #	Model, Number or Name	Description
14444.1	14'2" MAX. WIDE 24 GAGE SLAT ROLL UP DOOR	COLD FORMED SLATS INTERLOCKED TOGETHER AND RETAINED BY TRACKS TO PROVIDE HURRICANE PROTECTION AND ENTRANCE CLOSURE.
Limits of Use Approved for use in HVHZ: Yes Approved for use outside HVHZ: Yes Impact Resistant: Yes Design Pressure: +60/-60 Other:		Installation Instructions FL14444_R1_II_Drwg 11-233.pdf Verified By: Fenestration Testing Lab Created by Independent Third Party: Yes Evaluation Reports FL14444_R1_AE_Product Evaluation Report Drwg 11-233.pdf Created by Independent Third Party: Yes
14444.2	16'2" MAX. WIDE 22 GAGE SLAT ROLL UP DOOR	COLD FORMED SLATS INTERLOCKED TOGETHER AND RETAINED BY TRACKS TO PROVIDE HURRICANE PROTECTION AND ENTRANCE CLOSURE.
Limits of Use Approved for use in HVHZ: Yes Approved for use outside HVHZ: Yes Impact Resistant: Yes Design Pressure: +65/-65 Other:		Installation Instructions FL14444_R1_II_Drwg 11-249.pdf Verified By: Fenestration Testing Lab Created by Independent Third Party: Yes Evaluation Reports FL14444_R1_AE_Product Evaluation Report Drwg 11-249.pdf Created by Independent Third Party: Yes
14444.3	26'0" MAX. WIDE 20 GAGE SLAT ROLL UP DOOR	COLD FORMED SLATS INTERLOCKED TOGETHER AND RETAINED BY TRACKS TO PROVIDE HURRICANE PROTECTION AND ENTRANCE CLOSURE.
Limits of Use Approved for use in HVHZ: Yes Approved for use outside HVHZ: Yes Impact Resistant: Yes Design Pressure: +70/-70 Other:		Installation Instructions FL14444_R1_II_Drwg 11-234.pdf Verified By: Fenestration Testing Lab Created by Independent Third Party: Yes Evaluation Reports FL14444_R1_AE_Product Evaluation Report Drwg 11-234.pdf Created by Independent Third Party: Yes

[Back](#) [Next](#)

Contact Us :: 1940 North Monroe Street, Tallahassee FL 32399 Phone: 850-487-1824

The State of Florida is an AA/EEO employer. Copyright 2007-2013 State of Florida. :: [Privacy Statement](#) :: [Accessibility Statement](#) :: [Refund Statement](#)

Under Florida law, email addresses are public records. If you do not want your e-mail address released in response to a public-records request, do not send electronic mail to this entity. Instead, contact the office by phone or by traditional mail. If you have any questions, please contact 850.487.1395. *Pursuant to Section 455.275(1), Florida Statutes, effective October 1, 2012, licensees licensed under Chapter 455, F.S. must provide the Department with an email address if they have one. The emails provided may be used for official communication with the licensee. However email addresses are public record. If you do not wish to supply a personal address, please provide the Department with an email address which can be made available to the public. To determine if you are a licensee under Chapter 455, F.S., please click [here](#).

Product Approval Accepts:



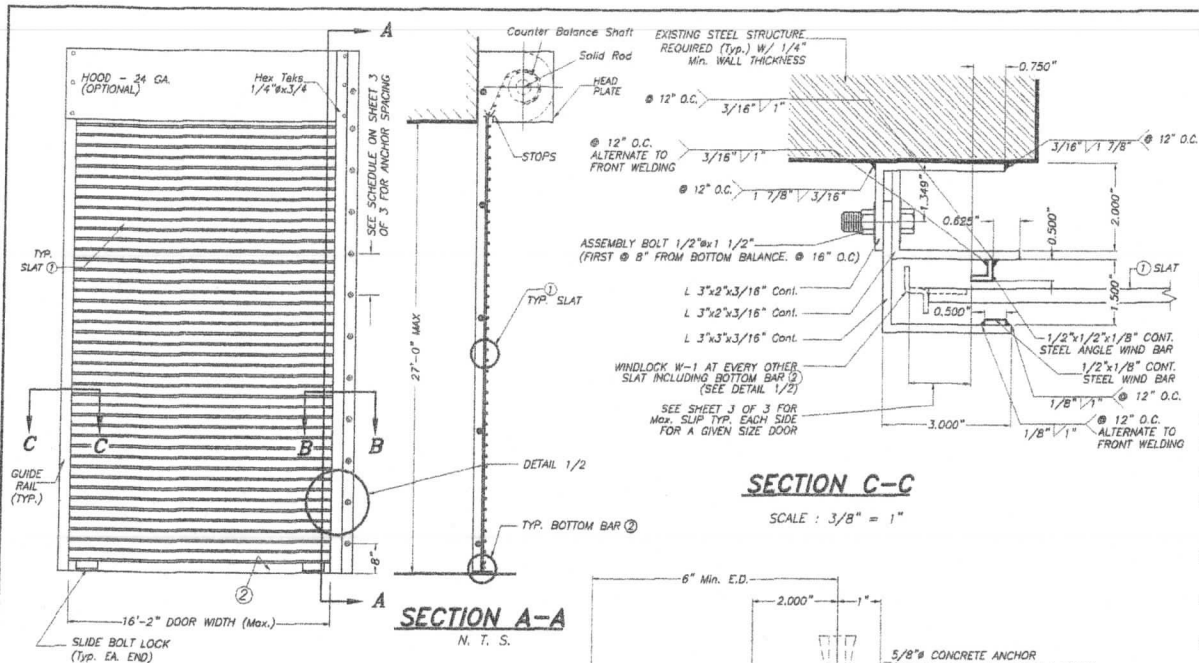

GENERAL NOTES:

- ROLL-UP DOOR SHOWN ON THIS PRODUCT EVALUATION DOCUMENT (P.E.D.) HAS BEEN VERIFIED FOR CODE COMPLIANCE IN ACCORDANCE WITH THE 2010 EDITION OF THE FLORIDA BUILDING CODE. DESIGN WIND LOADS SHALL BE DETERMINED AS PER SECTION 1620 OF THE ABOVE MENTIONED CODE, FOR A WIND SPEED AS REQUIRED BY THE JURISDICTION WHERE THESE SHUTTERS WILL BE INSTALLED AND FOR A DIRECTIONALITY FACTOR $K_d=0.85$. USING ASCE 7-10 FOR INSTALLATIONS UNDER 2010 FBC AND SHALL NOT EXCEED THE MAXIMUM (A.S.D.) DESIGN PRESSURE RATINGS INDICATED ON THIS NOTE 1.
- IN ORDER TO VERIFY THE ABOVE CONDITION, ULTIMATE DESIGN WIND LOADS DETERMINED PER ASCE 7-10 SHALL BE FIRST REDUCED TO A.S.D. DESIGN WIND LOADS BY MULTIPLYING THEM BY 0.6 IN ORDER TO COMPARE THESE W/ MAX. (A.S.D) DESIGN PRESSURE RATINGS INDICATED ON THIS NOTE 1.
- ROLL-UP DOOR'S ADEQUACY FOR IMPACT AND FATIGUE RESISTANCE HAS BEEN VERIFIED IN ACCORDANCE WITH SECTION 1626 OF THE ABOVE MENTIONED CODE AS PER FENESTRATION TESTING LABORATORY, INC. REPORT # 5081, PER TAS-201, TAS-202 & TAS-203 PROTOCOLS.

- MAX. A.S.D. DESIGN PRESSURE RATING: +65.0, -65.0 PSF
- SLAT TO BE A.S.T.M. A-653 OR 50 STRUCTURAL QUALITY STEEL WITH MIN $F_y = 50.0$ ksi. AND G-90 GALVANIZING PER A.S.T.M. A-653, OR A.I.S.I. 304 SERIES STAINLESS STEEL MANUFACTURED WITH A MINIMUM YIELD STRENGTH OF $F_y = 50.0$ ksi.
 - ALL STEEL ANGLES TO BE A.S.T.M. A-36 DESIGNATION, SHOP PRIMED AGAINST CORROSION PRIOR TO INSTALLATION.
 - WINDLOCKS TO BE "MALLEABLE IRON" $F_y = 42$ ksi OR A.I.S.I. DESIGNATION STEEL W/ $F_y = 40$ ksi., CHROME OR NICKEL PLATED.
 - ALL ASSEMBLY BOLTS TO BE S.A.E. GRADE 2 CADMIUM PLATED OR GALVANIZED.
 - STEEL WINDBARS TO BE A.S.T.M. A-36 DESIGNATION, SHOP PRIMED PRIOR TO INSTALLATION.
 - HOOD TO BE 24 GA. A.S.T.M. A-653 DESIGNATION G-90 FINISH TYPE COATING.
 - ALL RIVETS TO BE A.I.S.I. C1006 SPHERODIZED ANNEALED ALUMINUM LOW CARBON COLD HEADING QUALITY STEEL, ZINC PLATED, W/ 55.0 ksi. MINIMUM TENSILE STRENGTH, AS MANUFACTURED BY UNIVERSAL RIVET, INC.
 - CONCRETE ANCHORS TO BE AS MANUFACTURED BY HILTI, INC AND SHALL BE INSTALLED FOLLOWING ALL OF THE RECOMMENDATIONS AND SPECIFICATIONS OF THE ANCHOR'S MANUFACTURER.
 - ALL WELDING TO CONFORM TO AMERICAN WELDING SOCIETY'S AWS D1.1 REGULATIONS. USE A.W.S. A5.1 OR A5.5 E60XX ELECTRODES MIN. 3/16" FILLET SIZE.
 - INSULATION MATERIAL SHALL BE EPS-EXPANDED POLYSTYRENE INSULATION, MANUFACTURED BY DYPLAST PRODUCTS LLC., W/ MIAMI DADE COUNTY PRODUCT APPROVAL.
 - IT SHALL BE THE RESPONSIBILITY OF THE CONTRACTOR TO VERIFY THAT THE EXISTING STRUCTURE IS DESIGNED TO SUPPORT V_x AND V_y FORCES AT BOTH JAMBS. SEE SCHEDULE ON SHEET 3 OF 3, FOR V_x & V_y VALUES.
 - ROLL-UP MECHANISM NOT PART OF THIS APPROVAL.
 - (A) THIS P.E.D. PREPARED BY THIS ENGINEER IS GENERIC AND DOES NOT PROVIDE INFORMATION FOR A SITE SPECIFIC PROJECT, I.E. WHERE THE SITE CONDITIONS DEVIATE FROM THE P.E.D.
 - (B) CONTRACTOR TO BE RESPONSIBLE FOR THE SELECTION, PURCHASE AND INSTALLATION OF THIS PRODUCT BASED ON THIS P.E.D. PROVIDED HE/SHE DOES NOT DEVIATE FROM THE CONDITIONS DETAILED ON THIS DOCUMENT. CONSTRUCTION SAFETY AT SITE IS THE CONTRACTOR'S RESPONSIBILITY.
 - (C) THIS P.E.D. WILL BE CONSIDERED INVALID IF MODIFIED.
 - (D) SITE SPECIFIC PROJECTS SHALL BE PREPARED BY A FLORIDA REGISTERED ENGINEER OR ARCHITECT WHICH WILL BECOME THE ENGINEER OF RECORD (E.O.R.) FOR THE PROJECT AND WHO WILL BE RESPONSIBLE FOR THE PROPER USE OF THE P.E.D. ENGINEER OF RECORD, ACTING AS A DELEGATED ENGINEER TO THE P.E.D. ENGINEER, SHALL SUBMIT TO THIS LATTER THE SITE SPECIFIC DRAWINGS FOR REVIEW.
 - (E) THIS P.E.D. SHALL BEAR THE DATE AND ORIGINAL SEAL AND SIGNATURE OF THE PROFESSIONAL ENGINEER OF RECORD THAT PREPARED IT.
 - PRODUCTS MANUFACTURER'S LABEL SHALL BE LOCATED ON A READILY VISIBLE LOCATION AT DOOR. ONE LABEL SHALL BE PLACED FOR EVERY OPENING, LABELING TO COMPLY WITH SECTION 1715.5.3.4 OF THE FLORIDA BUILDING CODE.

TYPICAL DOOR ELEVATION
N. T. S.

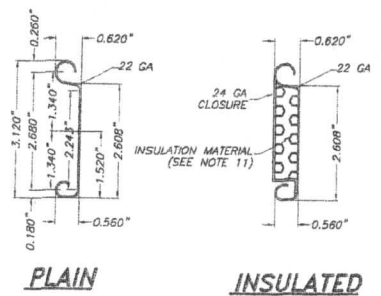

1 FLAT SLAT
SCALE: 1/2" = 1"

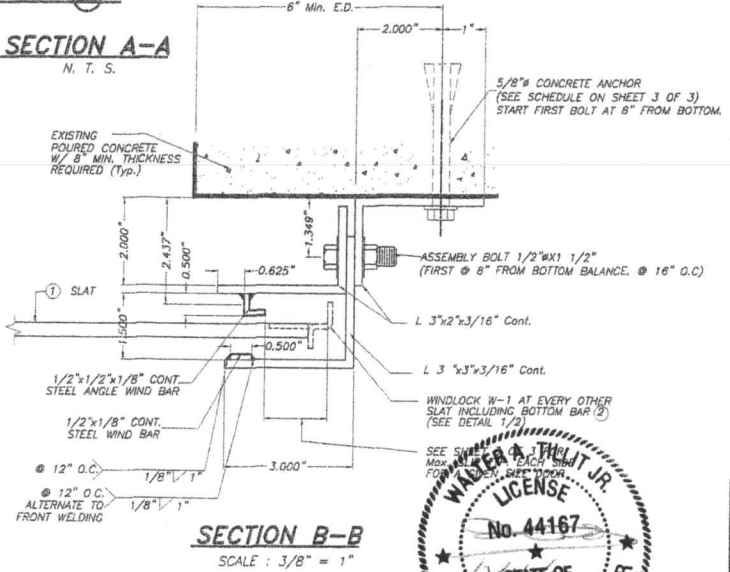

SECTION B-B
SCALE: 3/8" = 1"

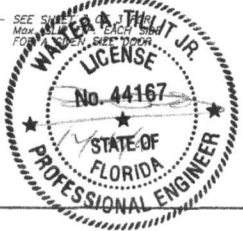

©2011 TILTECO, INC.

TILTECO INC.

TILLIT TESTING & ENGINEERING COMPANY
6385 NW 36th St. Ste. 305, WINDHAM PARKWAY, FL 33166
Phone: (305)871-1530 Fax: (305)871-1531
e-mail: tilliteco@aol.com
EE-0005719
WALTER A. TILLIT JR. P.E.
FLORIDA Lic. # 44167

Florida Building Code (High Velocity Hurricane Zone)

16'-2" MAX. 22 GAGE SLAT ROLL-UP DOOR		DRAWN BY: L.G./A.G.
ROLLING DOOR INDUSTRIES, LLC. 8214 NW 54 ST MIAMI, FL 33165 PH: 305-599-9977 FAX: 305-599-9978		12/16/11 DATE
		11-249 DRAWING No
REV. NO	DESCRIPTION	DATE
1	OLD DR-052	12/16/11
2		

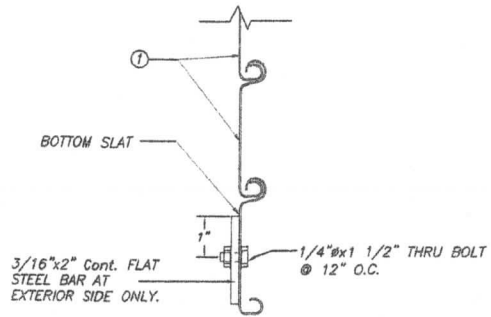

SECTION XI
② BOTTOM BAR DETAIL
 SCALE : 3/8" = 1"

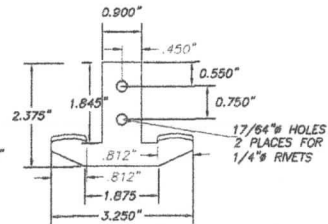
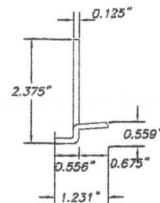
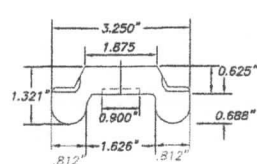

TYPICAL WINDLOCK W - 1 DETAIL
 SCALE : 3/8" = 1"

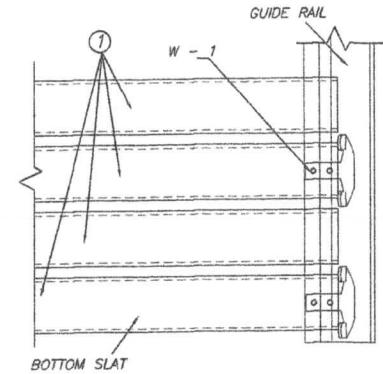

DETAIL 1 (elevation)
 N. T. S.

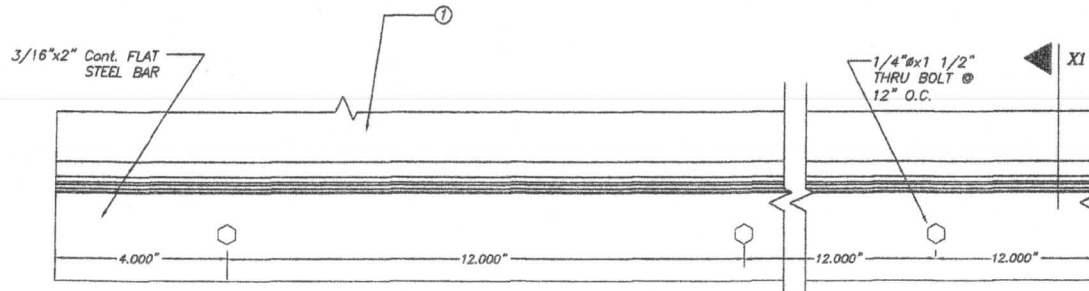

ELEVATION
BOTTOM BAR ②
 SCALE : 3/8" = 1"

Handwritten signature and date: 12/16/11

©2011 TILECO, INC.

TILECO INC.

TILLIT TESTING & ENGINEERING COMPANY
 6166 N.W. 36th St., Ste. 305, Miramar Gardens, FL 33166
 Phone: (305)871-1530, Fax: (305)871-1531
 e-mail: tillit@tillit.com
 EB-0008719
 WALTER A. TILLIT Jr., P.E.
 FLORIDA Lic. # 44187

Florida Building Code (High Velocity Hurricane Zone)

16'-2" MAX. 22 GAGE SLAT ROLL-UP DOOR		DRAWN BY: L.G./A.G.	
ROLLING DOOR INDUSTRIES, LLC.		12/16/11 DATE	
8214 NW 64 ST MIAMI, FL 33166 PH: 305-568-9977 FAX: 305-598-9979		11-249 DRAWING No	
REV. NO	DESCRIPTION	DATE	REV. NO
1	OLD DB-05E	12/16/11	
2			

Vx & Vy REACTIONS & ANCHOR SPACING SCHEDULE

MAXIMUM A.S.D. DESIGN PRESSURE RATING (PSF)	DOOR WIDTH (Ft.)	SLIP (in)	Vx (Lb/Ft)	Vy (Lb/Ft)	MAX. ANCHOR SPACING TO POURED CONCRETE															
					A *		B *			C *				D *						
					f'c = 2 ksi Min.	f'c = 3 ksi Min. OR GREATER	f'c = 2 ksi Min.	f'c = 3 ksi Min.	f'c = 4 ksi Min.	f'c = 6 ksi Min.	f'c = 2 ksi Min.	f'c = 3 ksi Min.	f'c = 4 ksi Min.	f'c = 6 ksi Min.	f'c = 2 ksi Min.	f'c = 3 ksi Min.	f'c = 4 ksi Min.	f'c = 6 ksi Min.		
+50.0, -50.0	10'-0"	7/32"	891	250	12"	12"	12"	12"	12"	12"	12"	12"	12"	12"	12"	12"	12"			
	12'-0"	3/8"	1051	300	12"	12"	12"	12"	12"	12"	11"	12"	12"	12"	11"	12"	12"			
	14'-0"	5/8"	1125	350	12"	12"	12"	12"	12"	12"	10 1/2"	12"	12"	12"	10"	12"	12"			
	16'-2"	1"	1179	404	12"	12"	12"	12"	12"	12"	9 1/2"	11 1/2"	12"	12"	9 1/2"	12"	12"			
+55.0, -55.0	10'-0"	7/32"	1017	275	12"	12"	12"	12"	12"	12"	11 1/2"	12"	12"	12"	11 1/2"	12"	12"			
	12'-0"	3/8"	1180	330	12"	12"	12"	12"	12"	12"	10"	12"	12"	12"	10"	12"	12"			
	14'-0"	5/8"	1254	385	12"	12"	11 1/2"	12"	12"	12"	9"	11"	12"	12"	9"	11 1/2"	12"			
	16'-2"	1"	1308	445	12"	12"	11"	12"	12"	12"	8 1/2"	10 1/2"	12"	12"	8 1/2"	10 1/2"	12"			
+60.0, -60.0	10'-0"	7/32"	1141	300	12"	12"	12"	12"	12"	12"	10 1/2"	12"	12"	12"	10 1/2"	12"	12"			
	12'-0"	3/8"	1307	360	12"	12"	11"	12"	12"	12"	9"	10 1/2"	12"	12"	9"	11"	12"			
	14'-0"	5/8"	1381	420	11 1/2"	12"	10 1/2"	11 1/2"	12"	12"	8 1/2"	10"	11 1/2"	12"	8 1/2"	10 1/2"	12"			
	16'-2"	1"	1436	485	11"	12"	10"	11"	12"	12"	8"	9 1/2"	11"	12"	8"	9 1/2"	11 1/2"			
+65.0, -65.0	10'-0"	7/32"	1263	325	12"	12"	11 1/2"	12"	12"	12"	9 1/2"	11"	12"	12"	9 1/2"	11 1/2"	12"			
	12'-0"	3/8"	1432	390	11"	12"	10"	11 1/2"	12"	12"	8"	9 1/2"	11 1/2"	12"	8"	10"	12"			
	14'-0"	5/8"	1507	455	10 1/2"	12"	9 1/2"	10 1/2"	11 1/2"	12"	7" \diamond	9"	10 1/2"	12"	7 1/2"	9 1/2"	11"			
	16'-2"	1"	1562	525	10"	12"	9"	10"	11"	12"	6 1/2" \diamond	8 1/2"	10"	12"	7 1/2"	9"	10 1/2"			

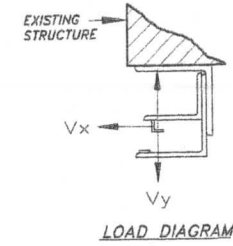
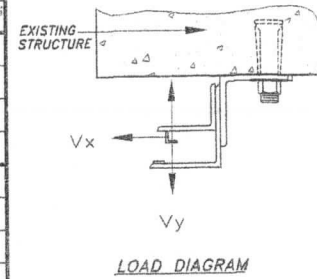

- *
A - 5/8" HILTI KWIK BOLT TZ EXPANSION ANCHOR @ 10" Min. SPACING.
B - 5/8" HILTI KWIK BOLT 3 EXPANSION ANCHOR @ 9" Min. SPACING. ONLY ALLOWED TO BE USED AT JURISDICTIONS WHERE COMPLIANCE W/ ACI 318-05 APPENDIX D IS NOT ENFORCED BY BUILDING OFFICIAL.
C - 5/8" HILTI HUS-H SCREW ANCHOR @ 8" Min. SPACING EXCEPT WHERE \diamond MARK 6 1/2" Min. SPACING IS ALLOWED.
D - 5/8" POWER FASTENER WEDGE BOLT ANCHOR W/ 7 1/2" Min. SPACING.
 ALL 3 ANCHORS W/ 4" MINIMUM EMBEDMENT, 6" MIN. EDGE DISTANCE & 8" MIN. WALL THICKNESS.



© 2011 TILTECO, INC.
TILTECO INC.
 TILLIT TESTING & ENGINEERING COMPANY
 6325 N.W. 36th St., Ste. 305, WILMINGTON, FL 33166
 Phone: (305) 871-1535 Fax: (305) 971-1631
 e-mail: tilteco@aol.com
 EB-0006719
 WALTER A. TILLIT Jr. P.E.
 FLORIDA LIC. # 44167

Florida Building Code (High Velocity Hurricane Zone)

16'-2" MAX. 22 GAGE SLAT ROLL-UP DOOR

ROLLING DOOR INDUSTRIES, LLC.
 8214 NW 64 ST
 MIAMI, FL 33166
 PH: 305-599-9977 FAX: 305-599-9978

REV. NO.	DESCRIPTION	DATE	REV. NO.	DESCRIPTION	DATE
1	OLD 28-052	12/16/11			
2					

DRAWN BY: L.G./A.G.
 DATE: 12/16/11
 DRAWING No: 11-249
 SHEET 3 OF 3