

CONTRACT DOCUMENTS FOR:



ITB # 21-001

Cable Huts Stabilization and Repair

October 2, 2020

MAYOR: TERI JOHNSTON

COMMISSIONERS:

GREGORY DAVILA

BILLY WARDLOW

JIMMY WEEKLEY

CLAYTON LOPEZ

SAMUEL KAUFMAN

MARY LOU HOOVER

PREPARED BY:
Karen A Wilman
City of Key West
Engineering Services

CITY OF KEY WEST
KEY WEST, FLORIDA
CONTRACT DOCUMENTS

For

CABLE HUTS STABILIZATION AND REPAIR ITB 21-001

INFORMATION TO BIDDERS

SUBJECT: INVITATION TO BID NO. 21-001:
CITY OF KEY WEST
CABLE HUTS STABILIZATION AND REPAIR

ISSUE DATE: **October 2, 2020**

MAIL OR SPECIAL
DELIVERY REPOSSES TO: CITY CLERK
CITY OF KEY WEST
1300 WHITE STREET
KEY WEST, FL 33040

DELIVER BIDS TO: SAME AS ABOVE.

MANDATORY PRE-BID: **October 8, 2020**

FINAL DATE FOR INQUIRIES: **October 12, 2020**

FINAL DATE FOR RESPONSES: **October 16, 2020**

BIDS MUST BE RECEIVED: **October 28, 2020**

NOT LATER THAN: 3:00 P.M. LOCAL TIME

Table of Contents

Page No.

PART 1 - BIDDING REQUIREMENTS

INVITATION TO BID	1
INSTRUCTIONS TO BIDDER	3
PROPOSAL FORM.....	8
FLORIDA BID BOND	15
ANTI – KICKBACK AFFIDAVIT	17
FLORIDA STATUTES, ON PUBLIC ENTITY CRIMES.....	18
INDEMNIFICATION FORM	21
LOCAL VENDORS FORM.....	22
DOMESTIC PARTNERSHIP AFFIDAVIT	23
CONE OF SILENCE AFFIDAVIT	24
NON-COLUSION AFFIDAVIT.....	25
BIDDER'S CHECKLIST.....	26

PART 2 - CONTRACT

CONTRACT	28
PERFORMANCE BOND.....	30
PAYMENT BOND.....	32

PART 3 - CONDITIONS OF THE CONTRACT

GENERAL CONDITIONS	35
SUPPLEMENTARY CONDITIONS	57

PART 4 - GENERAL REQUIREMENTS & SCOPE OF WORK

SECTION 01001 – GENERAL REQUIREMENTS.....	73
SECTION 01010 – SCOPE OF WORK.....	79
SECTION 01300 – SUBMITTALS.....	81

PART 5 - CONSTRUCTION DRAWINGS

PART 6 – SPECIFICATIONS

PART 7 – HISTORIC ARCHITECTURAL REVIEW COMMISSION (HARC)

PART 1

BIDDING REQUIREMENTS

INVITATION TO BID

Sealed bids for the City of Key West ITB# **21-001 CABLE HUTS STABILIZATION AND REPAIR**, addressed to the City of Key West, will be received at the Office of the City Clerk, 1300 White Street., Key West Florida, 33040 until **3:00 p.m.** on Wednesday, **October 28, 2020** and then publicly opened and read. Any bids received after the time and date specified will not be considered.

Please submit one (1) original, and two (2) flash drives each with one single PDF file of the sections entitled “Bidding Requirements” and “Contract Forms”. Bid package is to be enclosed in a sealed envelope, clearly marked on the outside “ITB # 21-001 CABLE HUTS STABILIZATION AND REPAIR” addressed and delivered to the City Clerk at the address noted above.

The project contemplated consists of providing all site work, materials, equipment and labor necessary to accomplish the following:

Stabilization and repair of the Cable Huts at Mallory Square that includes roof and concrete walls.

Drawings and Specifications may be obtained from Demand Star by Onvia or City of Key West. Please contact Demand Star at www.demandstar.com or call 1-800-711-1712 or www.cityofkeywest-fl.gov

A **Mandatory** Pre-bid meeting will be held at **11:00AM** on **October 8, 2020** at the site location of the **Cable Huts at Mallory Square, Wall Street.**

EACH BID MUST BE SUBMITTED ON THE PRESCRIBED FORM AND ACCOMPANIED BY BID SECURITY AS PRESCRIBED IN THE INSTRUCTIONS TO BIDDERS, PAYABLE TO THE CITY OF KEY WEST, FLORIDA, IN AN AMOUNT NOT LESS THAN FIVE (5) PERCENT OF THE AMOUNT BID.

THE BIDDER MUST BE A LICENSED CONTRACTOR BY THE STATE OF FLORIDA AND SUBMIT PROOF OF SUCH WITH THE BID.

The successful Bidder shall furnish documentation showing that he is in compliance with the licensing requirements of the State and the provisions of Chapter 66 Section 87 of the Code of Ordinances of the City of Key West; within 10 days following the Notice of Award and must demonstrate that he holds at a minimum, the following licenses & certificates;

- A. City of Key West Business Tax License Receipt
- B. A valid Certified General Contractors License issued by the State of Florida.

All bid bonds, insurance contracts, and certificates of insurance shall be either executed by or countersigned by a licensed resident agent of the Surety or Insurance Company having their place of business in the State of Florida, and in all ways complying with the insurance laws of the State of Florida. Further, the said Surety or Insurance Company shall be duly licensed and qualified to do business in the State of Florida.

Before a Contract will be awarded for the work contemplated herein, the CITY will conduct such investigation as is necessary to determine the performance record and ability of the apparent low Bidder to perform the size and type of work specified under this Contract. Upon request, the Bidder shall submit such information as deemed necessary by the CITY to evaluate the Bidder's qualifications.

Any request for information concerning this project must be made in writing, per City of Key West Ordinance Section 2-773, Cone of Silence, to Karen Wilman, Senior Construction Manager at karen.wilman@cityofkeywest-fl.gov

As stated above at the time of the bid submittal the Bidder must provide satisfactory documentation of State Licenses. The Bidder shall furnish documentation showing that he is in compliance with the licensing requirements of County, and City licenses as would be required within ten days of the award. The successful Bidder must also be able to satisfy the CITY Attorney as to such insurance coverage and legal requirements as may be demanded by the Bid in question. The CITY may reject bids for any and/or all of the following reasons: (1) for budgetary reasons, (2) if the bidder misstates or conceals a material fact in its bid, (3) if the bid does not strictly conform to the law or is non-responsive to the bid requirements, (4) if the bid is conditional, or (5) if a change of circumstances occurs making the purpose of the bid unnecessary to the CITY. The CITY may also waive any minor formalities or irregularities in any bid, (6) if such rejection is in the best interest of the CITY.

INSTRUCTIONS TO BIDDERS

1. CONTRACT DOCUMENTS

A. FORMAT

The Contract Documents are divided into parts, divisions, and sections for convenient organization and reference. Generally, there has been no attempt to divide the sections into work performed by the various building trades, work by separate subcontractors, or work required for separate facilities in the project.

B. DOCUMENT INTERPRETATION

The separate sections contained within these Contract Documents are intended to be mutually cooperative and to provide all details reasonably required for the execution of the proposed work.

Should there be any doubt as to the meaning or intent of said Contract Documents, the Bidder should request of the ENGINEER, in writing (at least ten (10) calendar days prior to bid opening) an interpretation thereof. Any interpretation or change in said Contract Documents will be made only in writing in the form of Addenda to the documents which will be available to all registered holders of Contract Documents via Demand star. Bidders shall submit with their Bids, or indicate receipt of, all Addenda. The CITY will not be responsible for any other explanation or interpretations of said Documents.

2. GENERAL DESCRIPTION OF THE PROJECT

A general description of the work to be done is contained in the Invitation to Bid. The scope is specified in applicable parts of these Contract Documents.

3. QUALIFICATION OF CONTRACTORS

The prospective Bidders must meet the statutorily prescribed requirements before award of Contract by the CITY. Bidders must hold or obtain all licenses and/or certificates as required by the State and Local Statutes to bid and perform the work specified herein.

4. BIDDER'S UNDERSTANDING

Each Bidder must inform himself of the conditions relating to the execution of the work, and it is assumed that he will inspect the site and make himself thoroughly familiar with all the Contract Documents. Failure to do so will not relieve the successful Bidder of their obligation to enter a Contract and complete the contemplated work in strict accordance with the Contract Documents. It shall be the Bidder's obligation to verify for themselves and to their complete satisfaction all information concerning site and subsurface conditions.

The CITY will make available to prospective Bidders upon request and at the office of the ENGINEER, prior to bid opening, any information that he may have as to subsurface conditions and surface topography at the worksite.

Each Bidder shall inform themselves of, and the Bidder awarded a Contract shall comply with,

federal, state, and local laws, statutes, and ordinances relative to the execution of the work. This requirement includes, but is not limited to, applicable regulations concerning minimum wage rates, nondiscrimination in the employment of labor, protection of public and employee safety and health, environmental protection, the protection of natural resources, fire protection, burning and non-burning requirements, permits, fees, and similar subjects.

5. TYPE OF BID

A. LUMP SUM

The BID for the work is to be submitted on a lump sum basis. Lump sum prices shall be submitted for all items of work set forth in the bid. All items required to complete the work specified but not included in the bid shall be considered incidental to those set forth in the bid.

6. PREPARATION OF BIDS

A. GENERAL

All blank spaces in the BID form must be filled in, as required, preferably in BLACK ink. All price information shall be shown in both words and figures where required. No changes shall be made in the phraseology of the forms. Written amounts shall govern in case of discrepancy between the amounts stated in writing and the amounts stated in figures. In case of discrepancy between unit prices and extended totals, unit prices shall prevail.

Any BID shall be deemed informal which contains omissions, erasures, alterations, or additions of any kind, or prices uncalled for, or in which any of the prices are obviously unbalanced, or which in any manner shall fail to conform to the conditions of the published Invitation to Bid.

Only one BID from any individual, firm, partnership, or corporation, under the same or different names, will be considered. Should it appear to the CITY that any Bidder is interested in more than one Bid for work contemplated; all Bids in which such Bidder is interested will be rejected.

B. SIGNATURE

The Bidder shall sign their BID in the blank space provided therefore. If Bidder is a corporation, the legal name of the corporation shall be set forth above, together with the signature of the officer or officers authorized to sign Contracts on behalf of the corporation. If Bidder is a partnership, the true name of the firm shall be set forth above, together with the signature of the partner or partners authorized to sign Contracts in behalf of the partnership. If signature is by an agent, other than an officer of a corporation or a member of a partnership, a notarized power-of-attorney must be on file with the CITY prior to opening of Bids or submitted with the Bid, otherwise the Bid will be regarded as not properly authorized.

C. SPECIAL BIDDING REQUIREMENTS

The Bidder's attention is brought to the hiring practices and licenses and permits of the City of Key West. These are defined in the addition to Article 39, ORDINANCES, PERMITS, AND LICENSES, as set forth in the Supplementary Conditions.

The Bidder shall submit with their Bid their experience record showing their experience and expertise in general construction projects and related work. Such experience record shall provide at least five current or recent projects (within the past 5 years) of similar work, within the State Florida and preferably Monroe County. For each project the following information shall be provided:

1. Description and location of work.
2. Contract amount.
3. Dates work was performed.
4. Owner.
5. Name of Owner's contact person and phone number.
6. ENGINEER.
7. Name of ENGINEER's contact person and phone number.

The bidder shall submit with their bid a list of items to be performed by their own labor and that performed by subcontractors or others.

D. ATTACHMENTS

Bidder shall complete and submit the following forms with their bid:

Anti-Kickback Affidavit
Public Entity Crimes Form
Indemnification Form
City of Key West Business License Tax Receipt
Local Vendors Form
Domestic Partnership Affidavit
Cone of Silence Affidavit
Non-Collusion Affidavit
Bidders' Checklist

E. PUBLIC ENTITY CRIMES FORM

Pursuant to the requirements of Chapter 287.133, Laws of Florida, pertaining to the sworn statement on Public Entity Crimes and the Convicted Vendor List, all Bidders shall submit a signed and notarized statement with their Bid on the form provided herein.

7. STATE AND LOCAL SALES AND USE TAXES

Unless the Supplementary Conditions contains a statement that the CITY is exempt from state sales tax on materials incorporated into the work due to the qualification of the work under this Contract, the Contractor, as required by the laws and statutes of the state and its political subdivisions, shall pay all state and local sales and use taxes. Prices quoted in the Bid shall include

all nonexempt sales and use taxes, unless provision is made in the Bid form to separately itemize the tax.

8. SUBMISSION OF BIDS

All BIDS must be submitted not later than the time prescribed, at the place, and in the manner set forth in the Invitation to Bid. BIDS must be made on the BID forms provided herewith, **submit one (1) ORIGINAL and two (2) FLASH DRIVES each containing a single PDF file of the entire bid package.**

Each BID must be submitted in a sealed envelope, so marked as to indicate the Bidder's name and its contents (project name and number) without being opened and addressed in conformance with the instructions in the Invitation to Bid.

9. MODIFICATION OR WITHDRAWAL OF BIDS

Prior to the time and date designated for receipt of BIDS, any BID submitted may be withdrawn by notice to the party receiving BIDS at the place designated for receipt of BIDS. Such notice shall be in writing over the signature of the Bidder or by telegram. If by telegram, written confirmation over the signature of the Bidder shall be mailed and postmarked on or before the date and time set for receipt of BID. No BID may be withdrawn after the time scheduled for opening of BIDS, unless the time specified in paragraph AWARD OF CONTRACT of these Instructions to Bidders shall have elapsed.

10. BID SECURITY

BIDS must be accompanied by cash, a certified check, or cashier's check drawn on a bank in good standing, or a bid bond issued by a Surety authorized to issue such bonds in the state where the work is located, in the amount of five (5) percent of the total amount of the Bid submitted. This bid security shall be given as a guarantee that the Bidder will not withdraw their BID for a period of ninety (90) days after bid opening, and that if awarded the Contract, the successful Bidder will execute the attached Contract and furnish properly executed Performance and Payment Bonds, each in the full amount of the Contract price within the time specified. Agent and Surety phone numbers must be provided.

The Attorney-in-Fact who executes this bond in behalf of the Surety must attach a notarized copy of their power-of-attorney as evidence of their authority to bind the Surety on the date of execution of the bond. Where State Statute requires, certification by a resident agent shall also be provided.

If the Bidder elects to furnish a Bid Bond, he shall use the Bid Bond form bound herewith, or one conforming substantially thereto in form and content.

11. RETURN OF BID SECURITY

Within 15 days after the award of the Contract, the CITY will return the bid securities to all Bidders whose BIDS are not to be further considered in awarding the Contract. Retained bid securities will be held until the Contract has been finally executed, after which all bid securities, other than Bidders' bonds and any guarantees, which have been forfeited, will be returned to the respective Bidders whose Bids they accompanied.

12. AWARD OF CONTRACT

Within ninety (90) calendar days after the opening of Bids, the CITY will accept one of the Bids or will act in accordance with the following paragraphs. The acceptance of the Bid will be by written notice of award, mailed to the office designated in the Bid, or delivered to the Bidder's representative. In the event of failure of the lowest responsive, responsible Bidder to sign the Contract, provide additional documents, insurance certificate(s) and evidence of holding required licenses and certificates, the Owner may award the Contract to the next lowest responsive, responsible Bidder. Such award, if made, will be made within one hundred & twenty (120) days after the opening of Bids.

The CITY reserves the right to accept or reject any or all Bids, and to waive any informalities and irregularities in said Bids.

13. BASIS OF AWARD

The award will be made by the Owner on the basis of the BID from the lowest, responsive, responsible BIDDER which, in the Owner's sole and absolute judgment will best serve the interest of the Owner.

14. EXECUTION OF CONTRACT

The successful Bidder shall, within ten (10) working days after receiving Notice of Award, sign and deliver to the CITY an original Contract and two (2) copies in the form hereto attached, together with the insurance certificate as required in the Contract Documents and evidence of holding required licenses and certificates. Within 10 working days after receiving the signed Contract from the successful Bidder, the City's authorized agent will sign the Contract. Signature by both parties constitutes execution of the Contract.

16. FAILURE TO EXECUTE CONTRACT AND FURNISH BID BOND

The Bidder who has a Contract awarded to them and who fails to promptly and properly execute the Contract shall forfeit the bid security that accompanied their bid, and the bid security shall be retained as liquidated damages by the CITY, and it is agreed that this said sum is a fair estimate of the amount of damages the CITY will sustain in case the Bidder fails to enter into a Contract. Bid security deposited in the form of cash, a certified check, or cashier's check shall be subject to the same requirement as a Bid Bond.

17. TIME OF COMPLETION

The time of completion of the work to be performed under this Contract is the essence of the Contract. Delays and extensions of time may be allowed in accordance with the provisions stated in the General Conditions.

When the Contractor receives a Notice to Proceed, he shall commence work as soon as possible and shall complete all work within **120** calendar days as stipulated in this Bid.

NOTE TO BIDDER: Use preferably BLACK ink for completing this BID form.

PROPOSAL FORM

To: The City of Key West
Address: 1300 White Street, Key West, Florida 33040
Project Title: CABLE HUTS STABILIZATION AND REPAIR
ITB # 21-001

Bidder's contact person for additional information on this BID:

Company Name: Barracuda Builders of Key West, Inc.
Contact Name & Telephone #: Bryan Wofsey - (305) 396-7752
Email Address: info@BarracudaBuilders.com

BIDDER'S DECLARATION AND UNDERSTANDING

The undersigned, hereinafter called the Bidder, declares that the only persons or parties interested in this Bid are those named herein, that this Bid is, in all respects, fair and without fraud, that it is made without collusion with any official of the Owner, and that the Bid is made without any connection or collusion with any person submitting another Bid on this Contract.

The Bidder further declares that he has carefully examined the Contract Documents for the construction of the project, that he has personally inspected the site, that he has satisfied himself as to the quantities involved, including materials and equipment, and conditions of work involved, including the fact that the description of the quantities of work and materials, as included herein, is brief and is intended only to indicate the general nature of the work and to identify the said quantities with the detailed requirements of the Contract Documents, and that this Bid is made according to the provisions and under the terms of the Contract Documents, which Documents are hereby made a part of this Bid.

CONTRACT EXECUTION

The Bidder agrees that if this Bid is accepted, he will, within 10 days, not including Sundays and legal holidays, after Notice of Award, sign the Contract in the form annexed hereto, and will at that time, deliver to the Owner evidence of holding required licenses and certificates, and will, to the extent of their Bid, furnish all machinery, tools, apparatus, and other means of construction and do the work and furnish all the materials necessary to complete all work as specified or indicated in the Contract Documents.

CERTIFICATES OF INSURANCE

Bidder agrees to furnish the Owner, before commencing the work under this Contract, the certificates of insurance as specified in these Documents.

START OF CONSTRUCTION AND CONTRACT COMPLETION TIME

The Bidder further agrees to begin work within 10 calendar days after the date of the Notice to proceed and to complete the project, in all respects within **120** calendar days after the date of the Notice to Proceed.

LIQUIDATED DAMAGES

In the event the Bidder is awarded the Contract and shall fail to complete the work within the time limit or extended time limit agreed upon, as more particularly set forth in the Contract Documents, liquidated damages shall be paid to the Owner at the rate of \$250.00 per day for all work awarded until the work has been satisfactorily completed as provided by the Contract Documents.

ADDENDA

The Bidder hereby acknowledges that he has received Addenda No's. 1, 2,
3, _____, _____, _____, _____, _____, _____, _____, _____,
(Bidder shall insert No. of each Addendum received) and agrees that all addenda issued are hereby made part of the Contract Documents, and the Bidder further agrees that their Bid(s) includes all impacts resulting from said addenda.

SALES AND USE TAXES

The Bidder agrees that all federal, state, and local sales and use taxes are included in the stated bid prices for the work.

LUMP SUM

The Bidder further proposes to accept as full payment for the work proposed herein the amounts computed under the provisions of the Contract Documents and based on the following lump sum amounts. The Bidder agrees that the lump sum represent a true measure of the labor and materials required to perform the work, including all allowances for overhead and profit for each type and unit of work called for in these Contract Documents.

Payment for materials & equipment authorized by the Owner in a written Change Order but not listed in the Schedule of Values will be provided at suppliers' invoice plus 15 %.

Provided in Part 4 of these documents is a pre-itemized Schedule of Values broken down by trade and type of work, Bidders are to provide the cost of all LABOR & MATERIALS for use as a basis for payment. List items to be performed by CONTRACTOR's own forces and the estimated total cost of these items. (Use additional sheets if necessary.)

Concrete = \$87,715.00 _____

Framing, Sheathing, Decking = \$82,620.00 _____

Exterior Doors = \$7,840.00 _____

Demolition = \$19,860.00 _____

SUBCONTRACTORS

The Bidder further proposes that the following subcontracting firms or businesses will be awarded subcontracts for the following portions of the work if the Bidder is awarded the Contract:

Southernmost Electric , LLC
Name _____

3330 Northside Dr. Apt 312 , Key West , FL , 33040
Street City State Zip

Keys Roofing, Inc.
Name _____

PO Box 371227 , Key Largo , FL , 33037
Street City State Zip

Florida Keys Excavating, LLC
Name

418 Blackbeard Rd., Little Torch Key, FL, 33042
Street City State Zip

Professional Plastering Designs, Inc.
Name

5409 Overseas Highway, Marathon, FL, 33050
Street City State Zip

SURETY

Philadelphia Indemnity Insurance Company whose address is

1 Bala Plaza Suite 100, Bala Cynwyd, PA, 19004
Street City State Zip

BIDDER

The name of the Bidder submitting this Bid is

Barracuda Builders of Key West, Inc. doing business at

5601 3rd Avenue, Key West, FL, 33040
Street City State Zip

which is the address to which all communications concerned with this Bid and with the Contract shall be sent.

The names of the principal officers of the corporation submitting this Bid, or of the partnership, or of all persons interested in this Bid as principals are as follows:

Bryan Wofsey - President / 100% Owner

If Sole Proprietor or Partnership

IN WITNESS hereto the undersigned has set their (its) hand this ____ day of _____ 2020.

Signature of Bidder

Title

If Corporation

IN WITNESS WHEREOF the undersigned corporation has caused this instrument to be executed and its seal affixed by its duly authorized officers this 28 day of October 2020.

(SEAL)

Barracuda Builders of Key West, Inc.

Name of Corporation

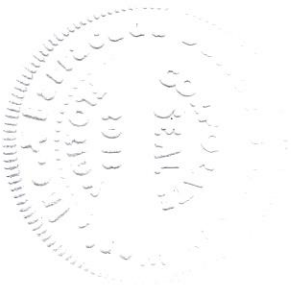

By 

Title President

Attest 
Secretary

FLORIDA BID BOND

BOND NO. _____

AMOUNT: \$ 622,000.00

KNOW ALL MEN BY THESE PRESENTS, that Barracuda Builders of Key West, Inc.

hereinafter called the PRINCIPAL, and PHILADELPHIA INDEMNITY INSURANCE COMPANY

a corporation duly organized under the laws of the State of PA

having its principal place of business at ONE BALA PLAZA SUITE 100, BALA CYNWYD, PA 19004

in the State of PA

and authorized to do business in the State of Florida, as SURETY, are held and firmly bound unto

City of Key West

hereinafter called the OBLIGEE, in the sum of Six Hundred Twenty Two Thousand & 00/100
DOLLARS (\$ 622,000.00) for the payment for which we bind ourselves,
our heirs, executors, administrators, successors, and assigns, jointly and severally, firmly by these
present.

THE CONDITION OF THIS BOND IS SUCH THAT:

WHEREAS, the PRINCIPAL is herewith submitting their or its Bid for
ITB # 21-001 / CABLE HUT STABILIZATION AND REPAIR / IS43022001 said Bid, by
reference thereto, being hereby made a part hereof.

WHEREAS, the PRINCIPAL contemplates submitting or has submitted a bid to the OBLIGEE for the furnishing of all labor, materials (except those to be specifically furnished by the CITY), equipment, machinery, tools, apparatus, means of transportation for, and the performance of the work covered in the Bid and the detailed Specifications, entitled:

ITB # 21-001 / CABLE HUT STABILIZATION AND REPAIR / IS43022001

WHEREAS, it was a condition precedent to the submission of said bid that a cashier's check, certified check, or bid bond in the amount of five (5) percent of the base bid be submitted with said bid as a guarantee that the Bidder would, if awarded the Contract, enter into a written Contract with the CITY for the performance of said Contract, within 10 working days after written notice having been given of the award of the Contract.

NOW, THEREFORE, the conditions of this obligation are such that if the PRINCIPAL within 10 consecutive calendar days after written notice of such acceptance, enters into a written Contract with the OBLIGEE and furnishes the Performance and Payment Bonds, each in an amount equal to 100 percent of the base bid, satisfactory to the CITY, then this obligation shall be void; otherwise the sum herein stated shall be due and payable to the OBLIGEE and the Surety herein agrees to pay said sum immediately upon demand of the OBLIGEE in good and lawful money of the United States of America, as liquidated damages for failure thereof of said PRINCIPAL.

Signed and sealed this 28th day of October, 2020.

PRINCIPAL

Barracuda Builders of Key West, Inc.

By [Signature]

STATE OF _____)
: SS
COUNTY OF _____)

PHILADELPHIA INDEMNITY INSURANCE COMPANY
SURETY

By [Signature]
Valerie Ann Aber, Attorney-In-Fact

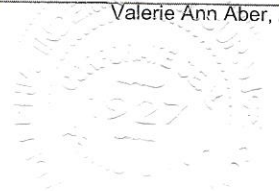

A NOTARY PUBLIC OR OTHER OFFICER COMPLETING THIS CERTIFICATE VERIFIES ONLY THE IDENTITY OF THE INDIVIDUAL WHO SIGNED THE DOCUMENT TO WHICH THIS CERTIFICATE IS ATTACHED, AND NOT THE TRUTHFULNESS, ACCURACY, OR VALIDITY OF THAT DOCUMENT

STATE OF ARIZONA
COUNTY OF MARICOPA } SS.

ON 10/29/2020 BEFORE ME, OLGA GONZALEZ

PERSONALLY APPEARED VALERIE ANN ABER, ATTORNEY-IN-FACT

WHO PROVED TO ME ON THE BASIS OF SATISFACTORY EVIDENCE TO BE THE PERSON(S) WHOSE NAME(S) IS/ARE SUBSCRIBED TO THE WITHIN INSTRUMENT AND ACKNOWLEDGED TO ME THAT HE/SHE/THEY EXECUTED THE SAME IN HIS/HER/THEIR AUTHORIZED CAPACITY(IES) AND THAT BY HIS/HER/THEIR SIGNATURE(S) ON THE INSTRUMENT THE PERSON(S), OR THE ENTITY UPON BEHALF OF WHICH THE PERSON(S) ACTED, EXECUTED THE INSTRUMENT.

I CERTIFY UNDER PENALTY OF PERJURY UNDER THE LAWS OF THE STATE OF ARIZONA THAT THE FOREGOING PARAGRAPH IS TRUE AND CORRECT.

WITNESS MY HAND AND OFFICIAL SEAL.

SIGNATURE

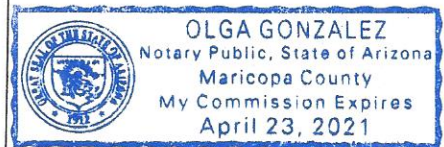
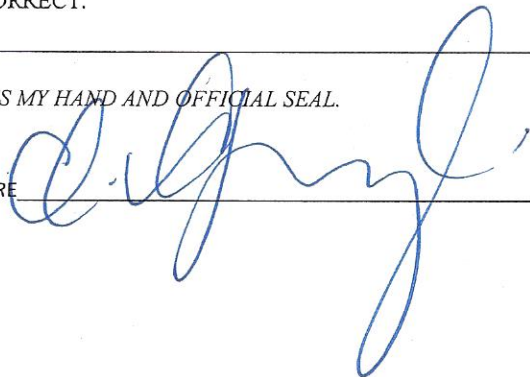

THIS AREA FOR OFFICIAL NOTORIAL SEAL

Bond # BID BOND

PHILADELPHIA INDEMNITY INSURANCE COMPANY
One Bala Plaza, Suite 100
Bala Cynwyd, PA 19004-0950

Power of Attorney

KNOW ALL PERSONS BY THESE PRESENTS: That PHILADELPHIA INDEMNITY INSURANCE COMPANY (the Company), a corporation organized and existing under the laws of the Commonwealth of Pennsylvania, does hereby constitute and appoint **Valerie Ann Aber and Daniel Rugge**, its true and lawful Attorney-in-fact with full authority to execute on its behalf bonds, undertakings, recognizances and other contracts of indemnity and writings obligatory in the nature thereof, issued in the course of its business and to bind the Company thereby, in an amount not to exceed \$50,000,000.

This Power of Attorney is granted and is signed and sealed by facsimile under and by the authority of the following Resolution adopted by the Board of Directors of PHILADELPHIA INDEMNITY INSURANCE COMPANY on the 14th of November, 2016.

RESOLVED: That the Board of Directors hereby authorizes the President or any Vice President of the Company: (1) Appoint Attorney(s) in Fact and authorize the Attorney(s) in Fact to execute on behalf of the Company bonds and undertakings, contracts of indemnity and other writings obligatory in the nature thereof and to attach the seal of the Company thereto; and (2) to remove, at any time, any such Attorney-in-Fact and revoke the authority given. And, be it

FURTHER RESOLVED: That the signatures of such officers and the seal of the Company may be affixed to any such Power of Attorney or certificate relating thereto by facsimile, and any such Power of Attorney so executed and certified by facsimile signatures and facsimile seal shall be valid and binding upon the Company in the future with respect to any bond or undertaking to which it is attached.

IN TESTIMONY WHEREOF, PHILADELPHIA INDEMNITY INSURANCE COMPANY HAS CAUSED THIS INSTRUMENT TO BE SIGNED AND ITS CORPORATE SEAL TO BE AFFIXED BY ITS AUTHORIZED OFFICE THIS 27TH DAY OF OCTOBER, 2017.

(Seal)

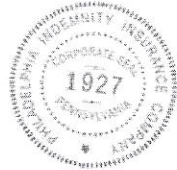

Robert D. O'Leary Jr., President & CEO
Philadelphia Indemnity Insurance Company

On this 27th day of October, 2017, before me came the individual who executed the preceding instrument, to me personally known, and being by me duly sworn said that he is the therein described and authorized officer of the PHILADELPHIA INDEMNITY INSURANCE COMPANY; that the seal affixed to said instrument is the Corporate seal of said Company; that the said Corporate Seal and his signature were duly affixed.

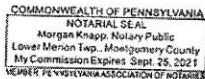

(Notary Seal)

Notary Public: Morgan Knapp
residing at: Bala Cynwyd, PA
My commission expires: September 25, 2021

I, Edward Sayago, Corporate Secretary of PHILADELPHIA INDEMNITY INSURANCE COMPANY, do hereby certify that the foregoing resolution of the Board of Directors and the Power of Attorney issued pursuant thereto on the 27th day of October, 2017 are true and correct and are still in full force and effect. I do further certify that Robert D. O'Leary Jr., who executed the Power of Attorney as President, was on the date of execution of the attached Power of Attorney the duly elected President of PHILADELPHIA INDEMNITY INSURANCE COMPANY.

In Testimony Whereof I have subscribed my name and affixed the facsimile seal of each Company this 28th day of October, 20 20.

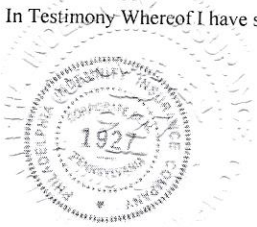

Edward Sayago, Corporate Secretary
PHILADELPHIA INDEMNITY INSURANCE COMPANY

ANTI – KICKBACK AFFIDAVIT

STATE OF Florida)
 : SS
COUNTY OF Monroe)

I, the undersigned hereby duly sworn, depose and say that no portion of the sum herein bid will be paid to any employees of the City of Key West as a commission, kickback, reward or gift, directly or indirectly by me or any member of my firm or by an officer of the corporation.

By:  Bryan Wofsey

Sworn and subscribed before me this 28 day of October, 2020.

NOTARY PUBLIC, State of Florida at Large

My Commission Expires:

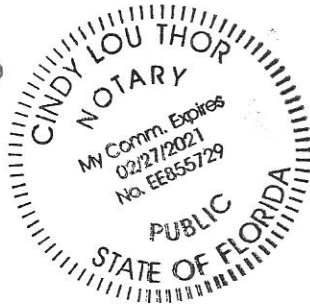

SWORN STATEMENT UNDER SECTION 287.133(3)(A)
FLORIDA STATUTES, ON PUBLIC ENTITY CRIMES

THIS FORM MUST BE SIGNED IN THE PRESENCE OF A NOTARY PUBLIC OR OTHER OFFICER AUTHORIZED TO ADMINISTER OATHS.

1. This sworn statement is submitted with Bid or Bid for ITB #21-001 Cable Hut Stabilization and Repair

2. This sworn statement is submitted by Barracuda Builders of Key West, Inc.
(Name of entity submitting sworn statement)
whose business address is 5601 3rd Avenue, Key West, FL 33040

and (if applicable) its Federal Employer Identification Number (FEIN) is 46-1840239

(If the entity has no FEIN, include the Social Security Number of the individual signing this sworn statement _____)

3. My name is Bryan Wofsey
(Please print name of individual signing)

and my relationship to the entity named above is President and Owner

4. I understand that a “public entity crime” as defined in Paragraph 287.133(1)(g), Florida Statutes, means a violation of any state or federal law by a person with respect to and directly related to the transaction of business with any public entity or with an agency or political subdivision of any other state or with the United States, including but not limited to, any bid or contract for goods or services to be provided to any public or an agency or political subdivision of any other state or of the United States and involving antitrust, fraud, theft, bribery, collusion, racketeering, conspiracy, material misrepresentation.

5. I understand that “convicted” or “conviction” as defined in Paragraph 287.133(1)(b), Florida Statutes, means a finding of guilt or a conviction of a public entity crime, with or without an adjudication guilt, in any federal or state trial court of record relating to charges brought by indictment information after July 1, 1989, as a result of a jury verdict, nonjury trial, or entry of a plea of guilty or nolo contendere.

6. I understand that an “affiliate” as defined in Paragraph 287.133(1)(a), Florida Statutes, means

- a. A predecessor or successor of a person convicted of a public entity crime; or
 - b. An entity under the control of any natural person who is active in the management of the entity and who has been convicted of a public entity crime. The term "affiliate" includes those officers, directors, executives, partners, shareholders, employees, members, and agents who are active in the management of an affiliate. The ownership by one person of shares constituting controlling interest in another person, or a pooling of equipment or income among persons when not for fair market value under an arm's length agreement, shall be a prima facie case that one person controls another person. A person who knowingly enters into a joint venture with a person who has been convicted of a public entity crime in Florida during the preceding 36 months shall be considered an affiliate.
7. I understand that a "person" as defined in Paragraph 287.133(1)(8), Florida Statutes, means any natural person or entity organized under the laws of any state or of the United States with the legal power to enter into a binding contract and which bids or applies to bid on contracts for the provision of goods or services let by a public entity, or which otherwise transacts or applies to transact business with public entity. The term "person" includes those officers, directors, executives, partners, shareholders, employees, members, and agents who are active in management of an entity.
8. Based on information and belief, the statement which I have marked below is true in relation to the entity submitting this sworn statement. (Please indicate which statement applies).

Neither the entity submitting this sworn statement, nor any officers, directors, executives, partners, shareholders, employees, members, or agents who are active in management of the entity, nor any affiliate of the entity have been charged with and convicted of a public entity crime subsequent to July 1, 1989, AND (Please indicate which additional statement applies.)

There has been a proceeding concerning the conviction before a hearing of the State of Florida, Division of Administrative Hearings. The final order entered by the hearing officer did not place the person or affiliate on the convicted vendor list. (Please attach a copy of the final order.)

The person or affiliate was placed on the convicted vendor list. There has been a subsequent proceeding before a hearing officer of the State of

Florida, Division of Administrative Hearings. The final order entered by the hearing officer determined that it was in the public interest to remove the person or affiliate from the convicted vendor list. (Please attach a copy of the final order.)

The person or affiliate has not been put on the convicted vendor list. (Please describe any action taken by or pending with the Department of General Services.)

[Handwritten Signature]

(Signature)

10/28/2020

(Date)

STATE OF Florida

COUNTY OF Monroe

PERSONALLY, APPEARED BEFORE ME, the undersigned authority,

Bryan Wofsey who, after first being sworn by me, affixed his/her
(Name of individual signing)

Signature in the space provided above on this 28 day of October, 2020.

My commission expires:

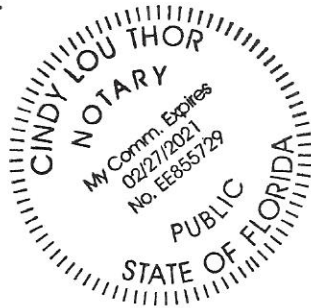

[Handwritten Signature]
NOTARY PUBLIC

INDEMNIFICATION

To the fullest extent permitted by law, the CONTRACTOR expressly agrees to indemnify and hold harmless the City of Key West, their officers, directors, agents, and employees (herein called the "indemnitees") from liabilities, damages, losses and costs, including, but not limited to, reasonable attorney's fees and court costs, such legal expenses to include costs incurred in establishing the indemnification and other rights agreed to in this Paragraph, to persons or property, to the extent caused by the negligence, recklessness, or intentional wrongful misconduct of the CONTRACTOR, its Subcontractors or persons employed or utilized by them in the performance of the Contract. Claims by indemnitees for indemnification shall be limited to the amount of CONTRACTOR's insurance or \$1 million per occurrence, whichever is greater. The parties acknowledge that the amount of the indemnity required hereunder bears a reasonable commercial relationship to the Contract and it is part of the project specifications or the bid documents, if any.

The indemnification obligations under the Contract shall not be restricted in any way by any limitation on the amount or type of damages, compensation, or benefits payable by or for the CONTRACTOR under workers' compensation acts, disability benefits acts, or other employee benefits acts, and shall extend to and include any actions brought by or in the name of any employee of the CONTRACTOR or of any third party to whom CONTRACTOR may subcontract a part or all of the Work. This indemnification shall continue beyond the date of completion of the work.

CONTRACTOR: Barracuda Builders of Key West, Inc.

SEAL:

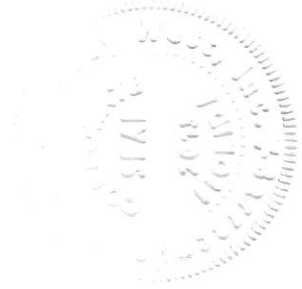

5601 3rd Avenue, Key West, FL 33040
Address

Signature

Bryan Wofsey
Print Name

President
Title

DATE: October 28, 2020

LOCAL VENDOR CERTIFICATION PURSUANT TO CKW ORDINANCE 09-22 SECTION 2-798

The undersigned, as a duly authorized representative of the vendor listed herein, certifies to the best of his/her knowledge and belief, that the vendor meets the definition of a "Local Business." For purposes of this section, "local business" shall mean a business which:

- a. Principle address as registered with the FL Department of State located within 30 miles of the boundaries of the city, listed with the chief licensing official as having a business tax receipt with its principle address within 30 miles of the boundaries of the city for at least one year immediately prior to the issuance of the solicitation.
- b. Maintains a workforce of at least 50 percent of its employees from the city or within 30 miles of its boundaries.
- c. Having paid all current license taxes and any other fees due the city at least 24 hours prior to the publication of the call for bids or request for Bids.

[] Not a local vendor pursuant to Ordinance 09-22 Section 2-798
 [X] Qualifies as a local vendor pursuant to Ordinance 09-22 Section 2-798

If you qualify, please complete the following in support of the self-certification & submit copies of your County and City business licenses. Failure to provide the information requested will result in denial of certification as a local business.

Business Name Barracuda Builders of Key West, Inc. Phone: (305) 396-7752

Current Local Address: 5601 3rd Avenue, Key West, FL 33040 Fax: (305) 396-7832
 (P.O Box numbers may not be used to establish status)

Length of time at this address: 7 years

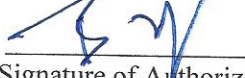

 Signature of Authorized Representative Date: 10/28/2020

STATE OF Florida COUNTY OF Monroe

The foregoing instrument was acknowledged before me this 28 day of October, 2020.

By Bryan Wofsey, of Barracuda Builders of Key West, Inc.
 (Name of officer or agent, title of officer or agent) (Name of corporation acknowledging)

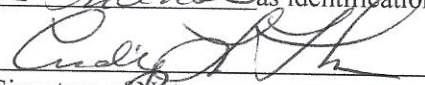
or has produced identification Florida Drivers License as identification
 (Type of identification)

 Signature of Notary

Return Completed form with
 Supporting documents to:
 City of Key West Purchasing

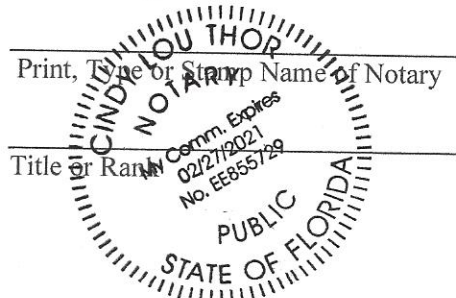

EQUAL BENEFITS FOR DOMESTIC PARTNERS AFFIDAVIT

STATE OF Florida)
 : SS
COUNTY OF Monroe)

I, the undersigned hereby duly sworn, depose and say that the firm of Barracuda Builders of Key West, Inc. provides benefits to domestic partners of its employees on the same basis as it provides benefits to employees' spouses per City of Key West Ordinance Sec. 2-799.

By: 

Sworn and subscribed before me this

28 Day of October, 2020.



NOTARY PUBLIC, State of Florida at Large

My Commission Expires:

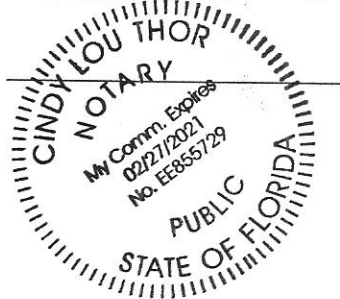

BIDDER'S CHECKLIST

(Note: The purpose of this checklist is to serve as a reminder of major items to be addressed in submitting a bid and is not intended to be all inclusive. It does not alleviate the Bidder from the responsibility of becoming familiar with all aspects of the Contract Documents and proper completion and submission of their bid.)

1. All Contract Documents thoroughly read and understood. [✓]
2. All blank spaces in Bid filled in, using black ink. [✓]
3. Total and unit prices added correctly and attached Schedule of Values [✓]
4. Addenda acknowledged. [✓]
5. Subcontractors are named as indicated in the Bid. [✓]
6. Experience record included. [✓]
7. Bid signed by authorized officer. [✓]
8. Bid Bond completed and executed, including power-of-attorney dated the same date as Bid Bond. [✓]
9. Bidder familiar with federal, state, and local laws, ordinances, rules and regulations affecting performance of the work. [✓]
10. Bidder, if successful, able to obtain and/or demonstrate possession of required licenses and certificates within (10) ten calendar days after receiving a Notice of Award. [✓]
11. BID submitted intact with the volume entitled "Bidding Requirements" and "Contract Forms", 1 original, and 2 flash drives as stated in the invitation to bid. [✓]
12. Bid Documents submitted in sealed envelope and addressed and labeled in conformance with the instructions in the Invitation to Bid. [✓]

PART 2

CONTRACT FORMS

CONTRACT

This Contract, made and entered into this _____ day of _____ 2020,

by and between the CITY OF KEY WEST, hereinafter called the "Owner", and _____

hereinafter called the "Contractor";

WITNESSETH:

The Contractor, in consideration of the sum to be paid them by the Owner and of the covenants and agreements herein contained, hereby agrees at their own proper cost and expense to do all the work and furnish all the materials, tools, labor, and all appliances, machinery, and appurtenances for ITB# 21-001, **CABLE HUTS STABILIZATION AND REPAIR**, Key West, Florida to the extent of the Bid made by the Contractor, dated the _____ th day of _____ 2020, all in full compliance with the Contract Documents referred to herein.

The CONTRACT DOCUMENTS, including the signed copy of the BID, BID BOND, CONTRACT FORM, SUMMARY OF WORK, SPECIFICATIONS, DRAWINGS, GENERAL & SUPPLEMENTARY CONDITIONS OF THE CONTRACT.

In consideration of the performance of the work as set forth in these Contract Documents, the Owner agrees to pay to the Contractor the amount bid in the Bid as adjusted in accordance with the Contract Documents, or as otherwise herein provided, and to make such payments in the manner and at the times provided in the Contract Documents.

The Contractor agrees to complete the work within ninety (**120**) calendar days and to accept as full payment hereunder the amounts computed as determined by the Contract Documents and based on the said BID.

The Contractor agrees to remedy all defects appearing in the work or developing in the materials furnished and the workmanship performed under this Contract during the warranty period after the date of final acceptance of the work by the Owner, and further agrees to indemnify and save the Owner harmless from any costs encountered in remedying such defects.

It is agreed that the Contract, based upon the BID, shall be fully complete within the stated number of consecutive calendar days from the date the Notice to Proceed is issued.

In the event the Contractor fails to complete the work within the time limit or extended time limit agreed upon, as more particularly set forth in the Contract Documents, liquidated damages shall be paid at a rate of **\$250.00** per day. Sundays and legal holidays shall be included in determining days in default.

This contract will automatically expire upon completion of the project. Contractors warranty obligations remain in effect.

IN WITNESS WHEREOF, we, the parties hereto, each herewith subscribe the same this

_____ Day of _____, A.D., 2020.

CITY OF KEY WEST

By (Printed Name)_____

By (Signature)_____

Title City Manager (OR DESIGNATED REPRESENTATIVE)

CONTRACTOR

By (Printed Name)_____

By (Signature)_____

Title_____

FLORIDA PERFORMANCE BOND

BOND NO. _____

AMOUNT: \$ _____

KNOW ALL MEN BY THESE PRESENTS, that in accordance with Florida Statutes Section 255.05, _____

with offices, at _____

hereinafter called the CONTRACTOR, (Principal), and _____

with offices, at _____

a corporation duly organized and existing under and by virtue of the laws of the State of _____, hereinafter called the SURETY, and authorized to transact business within the State of Florida, as SURETY, are held and firmly bound CITY OF KEY WEST,

represented by its _____, hereinafter called the City (Obligee), in the sum of:

_____ DOLLARS (\$ _____),

lawful money of the United States of America, for the payment of which, well and truly be made to the CITY, and the CONTRACTOR and the SURETY bind themselves and each of their heirs, executors, administrators, successors, and assigns, jointly and severally, firmly by these presents as follows:

THE CONDITION OF THE ABOVE OBLIGATION IS SUCH THAT:

WHEREAS, the CONTRACTOR has executed and entered into a certain Contract hereto attached, with the CITY, dated _____, 2020, to furnish at their own cost, charges, and expense all the necessary materials, equipment, and/or labor in strict and express accordance with said Contract and the Contract Documents as defined therein, all of which is made a part of said Contract by certain terms and conditions in said Contract more particularly mentioned, which Contract, consisting of the various Contract Documents is made a part of this Bond as fully and completely as if said Contract Documents were set forth herein;

NOW THEREFORE, the conditions of this obligation are such that if the above bounden CONTRACTOR:

1. Shall in all respects comply with the terms and conditions of said Contract and their obligation there under, including the Contract Documents (which include the permit form, coral relocation plan, specifications, and conditions as prepared by the CITY, invitation to bid, instructions to bidders, the CONTRACTOR'S bid as accepted by the above CITY, the bid and contract performance and payment bonds, and all addenda, if any, issued prior to the opening of bids),

being made a part of this bond by reference, at the times and in the manner prescribed in the contract; and

2. Promptly makes payments to all claimants, as defined in Section 255.05(1), Florida Statutes, supplying PRINCIPAL with labor, materials, or supplies, used directly or indirectly by PRINCIPAL in the prosecution of the work provided for in the contract; and

3. Pays CITY all losses, costs, expenses, damages, attorney's fees, including appellate proceedings, injury or loss of whatever kind and however arising including, without limitation, delay damages to which said CITY may be subject by reason of any wrongdoing, misconduct, want of care or skill, negligence, failure of performance, breach, failure to petition within the prescribed time, or default, including patent infringements, on the part of said CONTRACTOR, their agents or employees, in the execution or performance of said Contract; and

4. Performs the guarantee of all work and materials furnished under the contract for the time specified in the contract, then this obligation shall be void; otherwise, to remain in full force and effect for the term of said Contract.

AND, the said Surety for value received, hereby stipulates and agrees that no change involving any extension of time, or addition to the terms of the Contract Documents, or to the work to be performed, or materials to be furnished there under shall affect said obligation of said Surety on this Bond, and the said Surety does hereby waive notice of any such changes, extension of time, alterations, or additions of the terms of the Contract Documents, or to the work.

Any action instituted by a claimant under this bond for payment must be in accordance with the notice and time limitation provisions in Section 255.05(2), Florida Statutes.

IN WITNESS WHEREOF, the above parties bonded together have executed this instrument this day of _____, 2020, the name and corporate seal of each corporate party being hereto affixed and those presents duly signed by its undersigned representative, pursuant to authority of its governing body.

CONTRACTOR

By: _____ (Seal)

_____ Attest

SURETY

By _____ (Seal)

_____ Attest

FLORIDA PAYMENT BOND

BOND NO _____

AMOUNT: \$ _____

KNOW ALL MEN BY THESE PRESENTS, that in accordance with Florida Statutes Section 255.05, _____

with offices at _____

hereinafter called the CONTRACTOR, (Principal), and

_____ with offices at _____

a corporation duly organized and existing under and by virtue of the laws of the State of _____, hereinafter called the SURETY, and authorized to transact business within the State of Florida, as SURETY, are held and firmly bound CITY OF KEY WEST,

represented by its _____, hereinafter called the City (Obligee), in the sum of:

_____ DOLLARS (\$ _____), lawful money of the United States of America, for the payment of which, well and truly be made to the CITY, and the CONTRACTOR and the SURETY bind themselves and each of their heirs, executors, administrators, successors, and assigns, jointly and severally, firmly by these presents as follows:

THE CONDITION OF THE ABOVE OBLIGATION IS SUCH THAT:

WHEREAS, the CONTRACTOR has executed and entered into a certain Contract for

ITB 21-001 / CABLE HUTS STABILIZATION AND REPAIR / IS43022001

attached hereto, with the CITY, dated _____, 2020, to furnish at their own cost, charges, and expense the necessary materials, equipment, and/or labor in strict and express accordance with said Contract and the plans, drawings (if any), and specifications prepared by the CITY, all of which is made a part of said Contract by certain terms and conditions in said Contract more particularly mentioned, which Contract, consisting of the various Contract Documents specifically mentioned herein and relative hereto, is made a part of this Bond as fully and completely as if said Contract Documents were set forth herein.

NOW THEREFORE, the conditions of this obligation are such that if the above bounden CONTRACTOR shall in all respects comply with the terms and conditions of said Contract and their obligation thereunder, including the Contract Documents (which include the permit form,

coral relocation plan, the specifications, and conditions prepared by the CITY, invitation to bid, instructions to bidders, the CONTRACTOR'S bid as accepted by the CITY, the bid and contract and payment bonds, and all addenda, if any, issued prior to the opening of bids), and further that if said CONTRACTOR shall promptly make payments to all persons supplying materials, equipment, and/or labor, used directly or indirectly by said CONTRACTOR or SUBCONTRACTORS in the prosecution of the work for said contract in accordance with Florida Statutes, Section 255.05 or Section 713.23, then this obligation shall be void; otherwise to remain in full force and effect for the term of said contract, including and all guarantee periods as specifically mentioned in said Contract Documents.

AND, the said SURETY for value received, hereby stipulates and agrees that no change involving any extension of time, or addition to the terms of the Contract or to the work to be performed, or materials to be furnished thereunder, or in the Contract Documents and specifications accompanying the said contract shall affect said obligation of said SURETY on this Bond, and the said SURETY does hereby waive notice of any such changes, extension of time, alternations, or additions of the terms of the Contract, or to the work, to the Contract Documents, or to the specifications.

Claimant shall give written notice to the CONTRACTOR and the SURETY as required by Section 255.05 or Section 713.23, Florida Statutes. Any action instituted against the CONTRACTOR or SURETY under this bond for payment must be in accordance with the notice and time limitation provisions in Section 255.05(2) or Section 713.23, Florida Statutes.

IN WITNESS WHEREOF, the above parties bounded together have executed this instrument this _____ day of _____, 2020, the name and corporate seal of each corporate party being hereto affixed and those presents duly signed by its undersigned representative, pursuant to authority of its governing body.

CONTRACTOR

By: _____ (Seal)

Attest

SURETY

By _____ (Seal)

Attest

PART 3

CONDITIONS OF THE CONTRACT

GENERAL CONDITIONS
CONTENTS

Article

DEFINITIONS

1. AS APPROVED
2. AS SHOWN, AND AS INDICATED
3. BIDDER
4. CONTRACT DOCUMENTS
5. CONTRACTOR
6. CONTRACT COMPLETION
7. DAYS
8. DRAWINGS
9. ENGINEER
10. NOTICE
11. OR EQUAL
12. OWNER
13. PLANS
14. SPECIFICATIONS
15. NOTICE TO PROCEED
16. SUBSTANTIAL COMPLETION
17. WORK

CONTRACT DOCUMENTS

18. INTENT OF CONTRACT DOCUMENTS
19. DISCREPANCIES AND OMISSIONS
20. CHANGES IN THE WORK
21. EXAMINATION AND VERIFICATION OF CONTRACT DOCUMENTS
22. DOCUMENTS TO BE KEPT ON THE JOBSITE
23. ADDITIONAL CONTRACT DOCUMENTS
24. OWNERSHIP OF CONTRACT DOCUMENTS

THE ENGINEER

25. AUTHORITY OF THE ENGINEER
26. DUTIES AND RESPONSIBILITIES OF THE ENGINEER
27. LIMITATIONS ON ENGINEER'S RESPONSIBILITIES
28. REJECTED WORK
29. LINES AND GRADES
30. SUBMITTALS
31. DETAIL DRAWINGS AND INSTRUCTIONS

THE CONTRACTOR AND THEIR EMPLOYEES

32. CONTRACTOR, AN INDEPENDENT AGENT
32. (a) ASSIGNMENT OF CONTRACT

33. SUBCONTRACTING
34. INSURANCE AND LIABILITY
 - A. GENERAL
 - B. CONTRACTOR AND SUB-CONTRACTOR INSURANCE
 - C. COMPENSATION AND EMPLOYER'S LIABILITY INSURANCE
 - D. GENERAL LIABILITY INSURANCE (INCLUDING AUTOMOBILE)
 - E. BUILDER'S RISK ALL RISK INSURANCE
 - F. NO PERSONAL LIABILITY OF PUBLIC OFFICIALS
35. INDEMNITY
36. EXCLUSION OF CONTRACTOR CLAIMS
37. TAXES AND CHARGES
38. REQUIREMENTS OF STATE LAW FOR PUBLIC WORKS PROJECTS
39. CODES, ORDINANCES, PERMITS, AND LICENSES
40. SUPERINTENDENCE
41. RECEPTION OF ENGINEER'S COMMUNICATIONS
42. SAFETY
43. PROTECTION OF WORK AND PROPERTY
44. RESPONSIBILITY OF CONTRACTOR TO ACT IN AN EMERGENCY
45. MATERIALS AND APPLIANCES
46. CONTRACTORS' AND MANUFACTURERS' COMPLIANCE WITH STATE SAFETY, OSHA AND OTHER CODE REQUIREMENTS
47. SUBSTITUTION OF MATERIALS
48. TESTS, SAMPLES, AND OBSERVATIONS
49. ROYALTIES AND PATENT
50. CONTRACTOR'S RIGHT TO TERMINATE CONTRACT
51. CORRECTION OF DEFECTIVE WORK DURING WARRANTY PERIOD

PROGRESS OF THE WORK

52. BEGINNING OF THE WORK
53. SCHEDULES AND PROGRESS REPORTS
54. PROSECUTION OF THE WORK
55. OWNER'S RIGHT TO RETAIN IMPERFECT WORK
56. OWNER'S RIGHT TO DO WORK
57. OWNER'S RIGHT TO TRANSFER EMPLOYMENT
58. DELAYS AND EXTENSION OF TIME
59. DIFFERING SITE CONDITION

GENERAL CONDITIONS
CONTENTS

Article

- 60. LIQUIDATED DAMAGES
- 61. OTHER CONTRACTS
- 62. USE OF PREMISES
- 63. SUBSTANTIAL COMPLETION DATE
- 64. PERFORMANCE TESTING
- 65. OWNER'S USE OF PORTION OF THE WORK
- 66. CUTTING AND PATCHING
- 67. CLEANING UP

PAYMENT

- 68. CHANGE ORDERS
 - A. UNIT PRICE
 - B. LUMP SUM
 - C. COST REIMBURSEMENT
WORK
- 69. PARTIAL PAYMENTS
 - A. GENERAL
 - B. ESTIMATE
 - C. DEDUCTION FROM ESTIMATE
 - D. QUALIFICATIONS FOR
PARTIAL PAYMENT FOR
MATERIALS DELIVERED
 - E. PAYMENT
- 70. CLAIMS FOR EXTRA WORK
- 71. RELEASE OF LIENS OR CLAIMS
- 72. FINAL PAYMENT
- 73. NO WAIVER OF RIGHTS
- 74. ACCEPTANCE OF FINAL PAYMENT
CONSTITUTES RELEASE

DEFINITIONS

Whenever in the Contract Documents the following terms are used, the intent and meaning shall be interpreted as follows:

1. AS APPROVED

The words “as approved”, unless otherwise qualified, shall be understood to be followed by the words “by the ENGINEER for conformance with the Contract Document”.

2. AS SHOWN, AND AS INDICATED

The words “as shown” and “as Indicated” shall be understood to be followed by the words “on the Drawings”.

3. BIDDER

The person or persons, partnership, firm, or corporation submitting a Bid for the work contemplated.

4. CONTRACT DOCUMENTS

The “Contract Documents” consist of the Bidding Requirements, Contract Forms, Conditions of the Contract, Specifications, Drawings, all modifications thereof incorporated into the Documents before their execution, Change Orders, and all other requirements incorporated by specific reference thereto. These form the Contract.

5. CONTRACTOR

The person or persons, partnership, firm, or corporation who enters into the Contract awarded they by the OWNER.

6. CONTRACT COMPLETION

The “Contract Completion” is the date the OWNER accepts the entire work as being in compliance with the Contract Documents, or formally waives nonconforming work to extent of nonconformity, and issues the final payment in accordance with the requirements set forth in Article, “Final Payment” of these General Conditions.

7. DAYS

Unless otherwise specifically stated, the term “days” will be understood to mean calendar days. Business day or working day means any day other than Saturday, Sunday, or legal holiday.

8. DRAWINGS

The term “Drawings” refers to the official Drawings, Profiles, cross sections, elevations, details, and other working drawings and supplementary drawings, or reproductions thereof, signed by the ENGINEER, which shows the location, character, dimensions, and details of the work to be performed. Drawings may either be bound in the same book as the balance of the Contract Documents, or bound in separate sets, and are a part of the Contract Documents, regardless of the method of binding.

9. ENGINEER

The person or organization identified as such in the Contract Documents. The Term “ENGINEER” means ARCHITECT OR ENGINEER OF RECORD. or their authorized representative.

10. NOTICE

The term “notice” or the requirement to notify, as used in the Contract Documents or applicable state or federal statutes, shall signify a written communication delivered in person or by registered mail to the individual, or to a member of the firm, or to an officer of the corporation for whom it is intended. Certified or registered mail shall be addressed to the last business address known to them who gives the notice.

11. OR EQUAL

The term “or equal” shall be understood to indicate that the “equal” Product is equivalent to or better than the Product named in function, performance, reliability, quality, and general configuration. Determination of equality in reference to the Project design requirements will be made by the ENGINEER. Such equal Products shall not be purchased or installed by the CONTRACTOR without written authorization.

12. OWNER

The person, organization, or public body identified as such in the Contract Documents.

13. PLANS(See Drawings)

14. SPECIFICATIONS

The term “Specifications” refers to those portions of the Contract Documents consisting of written technical descriptions of materials, equipment, construction systems, standards, and workmanship as applied to the work and certain administrative details applicable thereto. Where standard specifications, such as those of ASTM, AASHTO, etc., have been referred to, the applicable portions of such standard specifications shall become a part of these Contract Documents. If referenced specifications conflict with specifications contained herein, the requirements contained herein shall prevail.

15. NOTICE TO PROCEED

A written notice given by the OWNER to the CONTRACTOR (with a copy to the ENGINEER) fixing the date on which the Contract time will commence to run and on which the CONTRACTOR shall start to perform their obligation under the Contract Documents. The Notice to Proceed will be given within 30 days following the execution of the Contract by the OWNER.

16. SUBSTANTIAL COMPLETION

“Substantial Completion” shall be that degree of completion of the Project or a defined portion of the Project, as evidenced by the ENGINEER’s written notice of Substantial Completion, sufficient to Provide the OWNER, at their discretion, the full-time use of the Project or defined portion of the Project for the purposes for which it was intended. “Substantial Completion” of an operating facility shall be that degree of completion that has Provided a minimum of 7 continuous days of successful, trouble-free, operation, which period shall begin after all performance and acceptance testing has been successfully demonstrated to the ENGINEER. All equipment contained in the work, plus all other components necessary to enable the OWNER to operate the facility in a manner that was intended, shall be complete on the substantial completion date.

17. WORK

The word “work” within these Contract Documents shall include all material, labor, tools, and all appliances, machinery, transportation, and appurtenances necessary to perform and complete the Contract, and such additional items not specifically indicated or described which can be reasonably inferred as belonging to the item described or indicated and as required by good Practice to Provide a complete and satisfactory system or structure. As used herein, “Provide” shall be understood to mean “furnish and install, complete in-place “.

CONTRACT DOCUMENTS

18. INTENT OF CONTRACT DOCUMENTS

The Contract Documents are complementary, and what is called for by one shall be as binding as if called for by all. The intent of the Documents is to describe a functionally complete Project (or part thereof) to be constructed in accordance with the Contract Documents. Any work, materials, or equipment that may reasonably be inferred from the Contract Documents as being required to produce the intended result shall be supplied whether or not specifically called for. When words which have a well-known technical or trade meaning are used to describe work, materials, or equipment, such words shall be interpreted in accordance with that meaning.

Reference to standard specifications, manuals, or codes of any technical society, organization or association, or to the laws or regulations of any governmental authority, whether such reference be specific or by implication, shall mean the latest standard specification, manual, code or laws or regulations in effect on the first published date of the Invitation to Bid, except as may be otherwise specifically stated. However, no Provision of any referenced standard specification, manual or code (whether or not specifically incorporated by reference in the Contract Documents) shall be effective to change the duties and responsibilities of OWNER, CONTRACTOR, or ENGINEER, or any of their consultants, agents, or employees from those set forth in the Contract Documents, nor shall it be effective to assign to ENGINEER, or any ENGINEER's consultants, agents, or employees, any duty or authority to supervise or direct the furnishing or performance of the work or any duty or authority to undertake responsibility contrary to the Provisions of Article LIMITATIONS ON ENGINEER'S RESPONSIBILITIES.

19. DISCREPANCIES AND OMISSIONS

Any discrepancies or omissions found in the Contract Documents shall be reported to the ENGINEER immediately. The ENGINEER will clarify discrepancies or omissions, in writing, within a reasonable time.

In resolving inconsistencies among two or more sections of the Contract Documents, Precedence shall be given in the following order:

- A. CONTRACT
- B. BID
- C. SUPPLEMENTARY CONDITIONS
- D. INVITATION TO BID
- E. INSTRUCTIONS TO BIDDERS
- F. GENERAL CONDITIONS
- G. SPECIFICATIONS
- H. DRAWINGS

Addenda shall take Precedence over all sections referenced therein. Figure dimensions on Drawings shall take precedence over scale dimensions. Detailed Drawings shall take precedence over general Drawings.

20. CHANGES IN THE WORK

The OWNER, without notice to the Sureties and without invalidating the Contract, may order changes in the work within the general scope of the Contract by altering, adding to, or deducting from the work, the Contract being adjusted accordingly. All such work shall be executed under the conditions of the original Contract, except as specifically adjusted at the time of ordering such change.

In giving instructions, the ENGINEER may order minor changes in the work not involving extra cost and not inconsistent with the purposes of the Project, but otherwise, except in an emergency endangering life and Property, additions or deductions from the work shall be performed only in pursuance of an approved Change Order from the OWNER, countersigned by the ENGINEER.

If the work is reduced by alterations, such action shall not constitute a claim for damages based on loss of anticipated Profits.

21. EXAMINATION AND VERIFICATION OF CONTRACT DOCUMENTS

The CONTRACTOR shall thoroughly examine and become familiar with all of the various parts of these Contract Documents and determine the nature and location of the work, the general and local conditions, and all other matters, which can in any way affect the work under this Contract. Failure to make an examination necessary for this determination shall not release the CONTRACTOR from the obligations of this Contract. No verbal agreement or conversation with any officer, agent, or employee of the OWNER or with the ENGINEER either before or after the execution of this Contract shall affect or modify any of the terms or obligations herein contained.

22. DOCUMENTS TO BE KEPT ON THE JOBSITE

The CONTRACTOR shall keep one copy of the Contract Documents on the job- site, in good order, available to the ENGINEER and to their representatives.

The CONTRACTOR shall maintain on a daily basis at the jobsite, and make available to the ENGINEER on request, one current record set of the Drawings which have been accurately marked to indicate all modifications in the completed work that differ from the design information shown on the Drawings. Upon Substantial completion of the work, the CONTRACTOR shall give the ENGINEER one complete set of these marked up record Drawings.

23. ADDITIONAL CONTRACT DOCUMENTS

Copies of Contract Documents or Drawings may be obtained on request from the ENGINEER and by paying the actual cost of reproducing the Contract Documents or Drawings.

24. OWNERSHIP OF CONTRACT DOCUMENTS

All portions of the Contract Documents, and copies thereof furnished by the ENGINEER are instruments of service for this Project. They are not to be used on other work and are to be returned to the ENGINEER on request at the completion of the work. Any reuse of these materials without specific written verification or adaptation by the ENGINEER will be at the risk of the user and without liability or legal expense to the ENGINEER. Such user shall hold the ENGINEER harmless from any and all damages, including reasonable attorneys' fees, from any and all claims arising from any such reuse. Any such verification and adaptation shall entitle the ENGINEER to further compensation at rates to be agreed upon by the user and the ENGINEER.

THE ENGINEER

25. AUTHORITY OF THE ENGINEER

The ENGINEER will be the OWNER's representative during the construction period. Their authority and responsibility will be limited to the Provisions set forth in these Contract Documents. The ENGINEER will have the Authority to reject work that does not conform to the Contract Documents. However, neither the ENGINEER's authority to act under this Provision, nor any decision made by them in good faith either to exercise or not to exercise such authority, shall give rise to any duty or responsibility of the ENGINEER to the CONTRACTOR, any SUBCONTRACTOR, their respective Sureties, any of their agents or employees, or any other person performing any of the work.

26. DUTIES AND RESPONSIBILITIES OF THE ENGINEER

The ENGINEER will make visits to the site at intervals appropriate to the various stages of construction to observe the Progress and quality of the work and to determine, in general, if the work is proceeding in accordance with the intent of

the Contract Documents. He will not make comprehensive or continuous review or observation to check quality or quantity of the work, and he will not be responsible for construction means, methods, techniques, sequences, or Procedures, or for safety Precautions and Programs in connection with the work. Visits and observations made by the ENGINEER shall not relieve the CONTRACTOR of their obligation to conduct comprehensive inspections of the work and to furnish materials and perform acceptable work, and to provide adequate safety Precautions, in conformance with the intent of the Contract.

The ENGINEER will make recommendations to the OWNER, in writing, on all claims of the OWNER or the CONTRACTOR arising from interpretation or execution of the Contract Documents. Such recommendations will be of factual and/or technical nature and will not include the legal interpretation of the Contract Documents. Any necessary legal interpretation of the Contract Document will be made by the OWNER. Such recommendation shall be necessary before the CONTRACTOR can receive additional money under the terms of the Contract. Changes in work ordered by the ENGINEER shall be made in compliance with Article CHANGES IN THE WORK.

One or more Project representatives may be assigned to observe the work. It is understood that such Project representatives shall have the authority to issue notice of nonconformance and make decisions within the limitations of the authority of the ENGINEER. The CONTRACTOR shall furnish all reasonable assistance required by the ENGINEER or Project representatives for Proper observation of the work. The above-mentioned Project representatives shall not relieve the CONTRACTOR of their obligations to conduct comprehensive inspections of the work and to furnish materials and perform acceptable work, and to provide adequate safety Precautions, in conformance with the intent of the Contract.

27. LIMITATIONS ON ENGINEER'S RESPONSIBILITIES

ENGINEER will not be responsible for CONTRACTOR's means, methods, techniques, sequences, or Procedures of construction, or the safety Precautions and Programs incident thereto, and ENGINEER will not be responsible for CONTRACTOR's failure to perform or furnish the work in accordance with the Contract Documents.

ENGINEER will not be responsible for the acts or omissions of CONTRACTOR or of any SUBCONTRACTOR, any supplier, or of any other person or organization performing or furnishing any of the work.

Whenever in the Contract Documents the terms "as ordered", "as directed", "as required", "as allowed", "as approved", or terms of like effect or import are used, or the adjectives "reasonable", "suitable", "acceptable", "Proper", or "satisfactory", or adjectives of like effect or import are used to describe a requirement, direction, review or judgment of ENGINEER as to the work, it is intended that such requirement, direction, review or judgment will be solely to evaluate the work for compliance with the Contract Documents (unless there is a specific statement indicating otherwise). The use of any such term or adjective shall not be effective to assign to ENGINEER any duty or authority to supervise or direct the furnishing or performance of the work or any duty or authority to undertake responsibility contrary to the Provisions of this Article.

28. REJECTED WORK

Any defective work or nonconforming materials or equipment that may be discovered at any time prior to expiration of the warranty period shall be removed and replaced by work which shall conform to the Provisions of the Contract Documents. Any material condemned or rejected shall be removed at once from the Project site.

Failure on the part of the ENGINEER to condemn or reject bad or inferior work or to note nonconforming materials or equipment on CONTRACTOR submittals shall not be construed to imply acceptance of such work. The OWNER shall reserve and retain all of its rights and remedies at law against the CONTRACTOR and its Surety for correction of any and all latent defects discovered after the guarantee period.

29. LINES AND GRADES

Lines and grades shall be established as provided in the supplementary conditions. All stakes, marks, and other reference

information shall be carefully preserved by the CONTRACTOR, and in case of their careless or unnecessary destruction or removal by them or their employees, such stakes, marks, and other information shall be replaced at the CONTRACTOR's expense.

30. SUBMITTALS

After checking and verifying all field measurements and after complying with applicable Procedures specified in Division I, GENERAL REQUIREMENTS, CONTRACTOR shall submit to ENGINEER, in accordance with the schedule for submittals for review, shop drawings, electrical diagrams, and catalog cuts for fabricated items and manufactured items (including mechanical and electrical equipment), which shall bear a stamp or specific written indication that CONTRACTOR has satisfied CONTRACTOR's responsibilities under the Contract Documents with respect to the review of the submittal. All submittals shall be identified as ENGINEER may require. The data shown shall be complete with respect to quantities, dimensions specified, performance and design criteria, materials, and similar data to enable ENGINEER to review the information. CONTRACTOR shall also submit to ENGINEER for review, with such promptness as to cause no delay in work, all samples required by the Contract Documents. All samples shall have been checked by and accompanied by a specific written indication that CONTRACTOR has satisfied CONTRACTOR's responsibilities under the Contract Documents with respect to the review of the submission and shall be identified clearly as to material, supplier, pertinent data such as catalog numbers and the use for which intended.

Before submission of each submittal, CONTRACTOR shall have determined and verified all quantities, dimensions, specified performance criteria, installation requirements, materials, catalog numbers, and similar data with respect thereto and reviewed or coordinated each submittal with other submittals and with the requirements of the work and the Contract Documents.

At the time of each submission, CONTRACTOR shall give ENGINEER specific written notice of each variation that the submittal may have from the requirements of the Contract Documents, and, in addition, shall cause a specific notation to be made on each shop drawing submitted to ENGINEER for review and approval of each variation.

ENGINEER will review submittals with reasonable Promptness, but ENGINEER's review will be only for conformance with the design concept of the Project and for compliance with the information given in the Contract Documents and shall not extend to means, methods, techniques, sequences, or Procedures of construction (except where a specific means, method, technique, sequence, or Procedure of construction is indicated in or required by the Contract Documents) or to safety Precautions or Programs incident thereto. The review of a separate item as such will not indicate review of the assembly in which the item functions. CONTRACTOR shall make corrections required by ENGINEER, and shall return the required number of corrected copies of shop drawings and submit as required new samples for review. CONTRACTOR shall direct specific attention in writing to revisions other than the corrections called for by ENGINEER on Previous submittals.

ENGINEER's review of submittals shall not relieve CONTRACTOR from the responsibility for any variation from the requirements of the Contract Documents unless CONTRACTOR has in writing called ENGINEER's attention to each such variation at the time of submission and ENGINEER has given written approval of each such variation by a specific written notation thereof incorporated therein or accompanying the shop drawing or sample approval; nor will any approval by ENGINEER relieve CONTRACTOR from responsibility for errors or omissions in the shop drawings or from responsibility for having complied with the Provisions herein.

Where a shop drawing or sample is required by the specifications, any related work performed prior to ENGINEER's review and approval of the pertinent submission shall be at the sole expense and responsibility of the CONTRACTOR.

31. DETAIL DRAWINGS AND INSTRUCTIONS

The ENGINEER will furnish, with reasonable Promptness, additional instructions by means of Drawings or otherwise, if, in the ENGINEER's opinion, such are required for the Proper execution of the work. All such Drawings and instructions will be consistent with the Contract Documents, true developments thereof, and reasonably inferable there from.

THE CONTRACTOR AND THEIR EMPLOYEES

32. CONTRACTOR, AN INDEPENDENT AGENT

The CONTRACTOR shall independently perform all work under this Contract and shall not be considered as an agent of the OWNER or of the ENGINEER, nor shall the CONTRACTOR’s SUBCONTRACTORS or employees be subagents of the OWNER or of the ENGINEER.

A. ASSIGNMENT OF CONTRACT

Assignment of any part or the whole of this Contract shall be subject to review and approval of the City Commission

33. SUBCONTRACTING

Unless modified in the Supplementary Conditions, within 10 days after the execution of the Contract, the CONTRACTOR shall submit to the ENGINEER the names of all SUBCONTRACTORS Proposed for the work, including the names of any SUBCONTRACTORS that were submitted with the Bid. The CONTRACTOR shall not employ any SUBCONTRACTORS to which the OWNER may object to as lacking capability to properly perform work of the type and scope anticipated.

The CONTRACTOR is as fully responsible to the OWNER for the acts and omissions of their SUBCONTRACTORS and of persons either directly or indirectly employed by them as they are responsible for the acts and omissions of persons directly employed by them.

Nothing contained in the Contract Documents shall create any contractual relationship between any SUBCONTRACTOR and the OWNER or ENGINEER.

34. INSURANCE AND LIABILITY

Contractor shall maintain limits no less than those stated below:

CONTRACTOR is to secure, pay for, and file with the City of Key West, prior to commencing any work under the Contract, all certificates for workers’ compensation, public liability, and property damage liability insurance, and such other insurance coverages as may be required by specifications and addenda thereto, in at least the following minimum amounts with specification amounts to prevail if greater than minimum amounts indicated. Notwithstanding any other provision of the Contract, the CONTRACTOR shall provide the minimum limits of liability insurance coverage as follows:

Auto Liability	\$1,000,000	Combined Single Limit
General Liability	\$2,000,000	Aggregate (Per Project)
	\$2,000,000	Products Aggregate
	\$1,000,000	Any One Occurrence
	\$1,000,000	Personal Injury
	\$300,000	Fire Damage/Legal

CONTRACTOR shall furnish an original Certificate of Insurance indicating, and such policy providing coverage to, City of Key West named as an additional insured on a PRIMARY and NON CONTRIBUTORY basis utilizing an ISO standard endorsement at least as broad as CG 2010 (11/85) or its equivalent, (combination of CG 20 10 07 04 and CG 20 37 07 04, providing coverage for completed operations, is acceptable) including a waiver of subrogation clause in favor of City of Key West on all policies. CONTRACTOR will maintain the General Liability and Umbrella Liability insurance coverages summarized above with coverage continuing in full force including the additional insured endorsement until at least 3 years beyond completion and delivery of the work contracted herein.

Notwithstanding any other provision of the Contract, the CONTRACTOR shall maintain complete workers' compensation coverage for each and every employee, principal, officer, representative, or agent of the CONTRACTOR who is performing any labor, services, or material under the Contract. Further, CONTRACTOR shall additionally maintain the following minimum limits of coverage:

Bodily Injury Each Accident	\$1,000,000
Bodily Injury by Disease Each Employee	\$1,000,000
Bodily Injury by Disease Policy Limit	\$1,000,000

CONTRACTOR's insurance policies shall be endorsed to give 30 days' written notice to the City of Key West in the event of cancellation or material change, using form CG 02 24, or its equivalent.

Certificates of Insurance submitted to the City of Key West will not be accepted without copies of the endorsements being requested. This includes additional insured endorsements, cancellation/material change notice endorsements, and waivers of subrogation. PLEASE ADVISE YOUR INSURANCE AGENT ACCORDINGLY.

CONTRACTOR will comply with any and all safety regulations required by any agency or regulatory body including but not limited to OSHA. CONTRACTOR will notify City of Key West immediately by telephone at (305) 809-3811 any accident or injury to anyone that occurs on the jobsite and is related to any of the work being performed by the CONTRACTOR.

A. NO PERSONAL LIABILITY OF PUBLIC OFFICIALS

In carrying out any of the Provisions hereof in exercising any authority granted by the Contract, there will be no personal liability upon any public official.

B. SURETY AND INSURER QUALIFICATIONS

All bonds, insurance contracts, and certificates of insurance shall be either executed by or countersigned by a licensed resident agent of the Surety or insurance company, having their place of business in the State of Florida, and in all ways complying with the insurance laws of the State of Florida. Further, the said Surety or Insurance Company shall be duly licensed and qualified to do business in the State of Florida. If requested, Contractor shall Provide Proof of Florida Licensure for all insurance companies. The City of Key West shall be named as Additional Insured on the insurance certificates.

35. INDEMNITY

To the fullest extent permitted by law, the CONTRACTOR expressly agrees to indemnify and hold harmless the City of Key West, their officers, directors, agents, and employees (herein called the "indemnitees") from liabilities, damages, losses and costs, including, but not limited to, reasonable attorney's fees and court costs, such legal expenses to include costs incurred in establishing the indemnification and other rights agreed to in this Paragraph, to persons or property, to the extent caused by the negligence, recklessness, or intentional wrongful misconduct of the CONTRACTOR, its Subcontractors or persons employed or utilized by them in the performance of the Contract. Claims by indemnitees for indemnification shall be limited to the amount of CONTRACTOR's insurance or \$1 million per occurrence, whichever is greater. The parties acknowledge that the amount of the indemnity required hereunder bears a reasonable commercial relationship to the Contract and it is part of the project specifications or the bid documents, if any. The indemnification obligations under the Contract shall not be restricted in any way by any limitation on the amount or type of damages, compensation, or benefits payable by or for the CONTRACTOR under workers' compensation acts, disability benefits acts, or other employee benefits acts, and shall extend to and include any actions brought by or in the name of any employee of the CONTRACTOR or of any third party to whom CONTRACTOR may subcontract a part or all the Work. This indemnification shall continue beyond the date of completion of the work.

36. EXCLUSION OF CONTRACTOR CLAIMS

In performing its obligations, the ENGINEER and its consultants may cause expense for the CONTRACTOR or its SUBCONTRACTORS and equipment or material suppliers. However, those parties and their sureties shall maintain no direct action against the ENGINEER, its officers, employees, agents, and consultants for any claim arising out of, in connection with, or resulting from the ENGINEERING services performed or required to be performed.

37. TAXES AND CHARGES

The CONTRACTOR shall withhold and pay any and all sales and use taxes and all withholding taxes, whether State or Federal, and pay all Social Security charges and also all State Unemployment Compensation charges, and pay or cause to be withheld, as the case may be, any and all taxes, charges, or fees or sums whatsoever, which are now or may hereafter be required to be paid or withheld under any laws.

38. REQUIREMENTS OF STATE LAW FOR PUBLIC WORKS PROJECTS

When the Contract Documents concern public works of the state or any county, municipality, or political subdivision created by its laws, the applicable statutes shall apply. All parties to this Contract shall determine the contents of all applicable statutes and comply with their Provisions throughout the performance of the Contract.

39. CODES, ORDINANCES, PERMITS AND LICENSES

The CONTRACTOR shall keep themselves fully informed of all local codes and ordinances, as well as state and federal laws, which in any manner affect the work herein specified. The CONTRACTOR shall at all times comply with said codes and ordinances, laws, and regulations, and protect and indemnify the OWNER, the ENGINEER and their respective employees, and its officers and agents against any claim or liability arising from or based on the violation of any such laws, ordinances, or regulations. All permits, licenses and inspection fees necessary for Prosecution and completion of the work shall be secured and paid for by the CONTRACTOR, unless otherwise specified.

A. NOISE ORDINANCE

City of Key West has a noise ordinance that allows working hours between 8:00 AM to 7:00 PM, Monday through Friday. No work should be performed during weekends or City Holidays, State Holidays and National Holidays. Any construction operations outside these hours and these days will require a variance from the City of Key West Commission.

B. "LICENSES"

THE BIDDER MUST BE A LICENSED CONTRACTOR BY THE STATE OF FLORIDA AND SUBMIT PROOF OF SUCH WITH THE BID.

1. Within 10 days of Notice of Award, the successful Bidder must represent that he holds all applicable, county, and City of Key West licenses and permits required to do business as a contractor with respect to the work described in the Contract Documents.
2. Further, the successful Bidder must, within 10 days of Notice of Award, furnish documentation showing that, as a minimum, he has complied with the provisions of Chapter 18 of the Code of Ordinances of the City of Key West to enter the Agreement contained in the Contract Documents.
3. Specifically, within 10 days after Notice of Award, the successful Bidder must demonstrate that he holds, as a minimum, the following licenses and certificates:
 - a.) City of Key West Tax License Receipt;

b.) A valid Certified Contractors License issued by the State of Florida.

40. SUPERINTENDENCE

The CONTRACTOR shall keep at the project site, competent supervisory personnel. The CONTRACTOR shall designate, in writing, before starting work, a Project superintendent who shall be an employee of the CONTRACTOR and shall have complete authority to represent and to act for the CONTRACTOR. ENGINEER shall be notified in writing prior to any change in superintendent assignment. The CONTRACTOR shall give efficient supervision to the work, using their best skill and attention. The CONTRACTOR shall be solely responsible for all construction means, methods, techniques, and Procedures, and for providing adequate safety Precautions and coordinating all portions of the work under the Contract. It is specifically understood and agreed that the ENGINEER, its employees and agents, shall not have control or charge of and shall not be responsible for the construction means, methods, techniques, procedures, or for providing adequate safety precautions in connection with the work under Contract.

The CONTRACTOR shall keep at the project site, competent supervisory personnel, able to read, write and speak English to effectively communicate with City staff.

41. RECEPTION OF ENGINEER'S COMMUNICATIONS

The superintendent shall receive for the CONTRACTOR all communications from the ENGINEER. Communications of major importance will be confirmed in writing upon request from the CONTRACTOR.

The ENGINEER may schedule Project meetings for the purposes of discussing and resolving matters concerning the various elements of the work. Time and place for these meetings and the names of persons required to be Present shall be as determined by the ENGINEER. CONTRACTOR shall comply with these attendance requirements and shall also require their SUBCONTRACTORS to comply.

42. SAFETY

The CONTRACTOR shall be solely and completely responsible for conditions of the jobsite, including safety of all persons (including employees) and Property during performance of the work. This requirement shall apply continuously and not be limited to normal working hours. Safety Provisions shall conform to U.S. Department of Labor (OSHA), and all other applicable federal, state, county, and local laws, ordinances, codes, and regulations. Where any of these are in conflict, the more stringent requirement shall be followed. The CONTRACTOR's failure to thoroughly familiarize themselves with the aforementioned safety Provisions shall not relieve them from compliance with the obligations and penalties set forth therein.

The CONTRACTOR shall develop and maintain for the duration of this Contract, a safety Program that will effectively incorporate and implement all required safety Provisions. The CONTRACTOR shall appoint an employee who is qualified and authorized to supervise and enforce compliance with the safety Program. The duty of the ENGINEER to conduct construction review of the work does not include review or approval of the adequacy of the CONTRACTOR's safety Program, safety supervisor, or any safety measures taken in, on, or near the construction site. The CONTRACTOR, as a part of their safety Program, shall maintain at their office or other well-known place at the jobsite, safety equipment applicable to the work as Prescribed by the aforementioned authorities, all articles necessary for giving first-aid to the injured, and shall establish the Procedure for the immediate removal to a hospital or a doctor's care of persons (including employees) who may be injured on the jobsite.

If death or serious injuries or serious damages are caused, the accident shall be reported immediately by telephone or messenger to both the ENGINEER and the OWNER. In addition, the CONTRACTOR must promptly report in writing to the ENGINEER all accidents whatsoever arising out of, or in connection with, the performance of the work whether on, or adjacent to, the site, giving full details and statements of witnesses.

If a claim is made by anyone against the CONTRACTOR or any SUBCONTRACTOR on account of any accident, the CONTRACTOR shall promptly report the facts in writing to the ENGINEER, giving full details of the claim.

A. OCCUPATIONAL SAFETY AND HEALTH

The Contractor shall observe and comply with all applicable local, state, and federal occupational safety and health regulations during the prosecution of work under this Contract. In addition, full compliance by the Contractor with the U.S. Department of Labor's Occupational Safety and Health Standards, as established in Public Law 91-596, will be required under the terms of this Contract.

43. PROTECTION OF WORK AND PROPERTY

The CONTRACTOR shall at all times safely guard and Protect from damage the OWNER's Property, adjacent Property, and their own work from injury or loss in connection with this Contract. All facilities required for Protection by federal, state, or municipal laws and regulations and local conditions must be provided and maintained. The CONTRACTOR shall Protect their work and materials from damage due to the nature of the work, the elements, carelessness of other CONTRACTORS, or from any cause whatever until the completion and acceptance of the work. All loss or damages arising out of the nature of the work to be done under these Contract Documents, or from any unforeseen obstruction or defects which may be encountered in the Prosecution of the work, or from the action of the elements, shall be sustained by the CONTRACTOR.

A. HISTORIC PRESERVATION

The Contractor shall comply with Florida's Archives and Historic Act (Florida Statutes, Chapter 267) and the regulations of the local historic preservation board as applicable and protect against the potential loss or destruction of significant historical or archaeological data, sites, and properties in connection with the project.

44. RESPONSIBILITY OF CONTRACTOR TO ACT IN AN EMERGENCY

In case of an emergency which threatens loss or injury of Property, and/or safety of life, the CONTRACTOR shall act, without previous instructions from the OWNER or ENGINEER, as the situation may warrant. The CONTRACTOR shall notify the ENGINEER thereof immediately thereafter. Any claim for compensation by the CONTRACTOR, together with substantiating documents in regard to expense, shall be submitted to the OWNER through the ENGINEER and the amount of compensation shall be determined by agreement.

45. MATERIALS AND APPLIANCES

Unless otherwise stipulated, the CONTRACTOR shall Provide and pay for all materials, labor, water, tools, equipment, heat, light, fuel, power, transportation, construction equipment and machinery, appliances, telephone, sanitary facilities, temporary facilities and other facilities and incidentals necessary for the execution and completion of the work.

Unless otherwise specified, all materials shall be new, and both workmanship and materials shall be of good quality. The CONTRACTOR shall, if required, furnish satisfactory evidence as to the kind and quality of materials.

In selecting and/or approving equipment for installation in the Project, the OWNER and ENGINEER assume no responsibility for injury or claims resulting from failure of the equipment to comply with applicable federal, state, and local safety codes or requirements, or the safety requirements of a recognized agency, or failure due to faulty design concepts, or defective workmanship and materials.

46. CONTRACTORS' AND MANUFACTURERS' COMPLIANCE WITH STATE SAFETY, OSHA, AND OTHER CODE REQUIREMENTS

The completed work shall include all necessary permanent safety devices, such as machinery guards and similar ordinary safety items required by the state and federal (OSHA) industrial authorities and applicable local and national codes. Further, any features of the work subject to such safety regulations shall be fabricated, furnished, and installed (including OWNER-furnished equipment) in compliance with these requirements. CONTRACTORS and manufacturers of equipment shall be held responsible for compliance with the requirements included herein. CONTRACTORS shall notify all equipment suppliers and SUBCONTRACTORS of the Provisions of this Article.

47. SUBSTITUTION OF MATERIALS

Except for OWNER-selected equipment items, and items where no substitution is clearly specified, whenever any material, article, device, Product, fixture, form, type of construction, or Process is indicated or specified by patent or Proprietary name, by name of manufacturer, or by catalog number, such specifications shall be deemed to be used for the purpose of establishing a standard of quality and facilitating the description of the material or Process desired. This Procedure is not to be construed as eliminating from competition other Products of equal or better quality by other manufacturers where fully suitable in design, and shall be deemed to be followed by the words "or equal". The CONTRACTOR may, in such cases, submit complete data to the ENGINEER for consideration of another material, type, or Process that shall be substantially equal in every respect to that so indicated or specified. Substitute materials shall not be used unless approved in writing. The ENGINEER will be the sole judge of the substituted article or material.

48. TESTS, SAMPLES, AND OBSERVATIONS

The CONTRACTOR shall furnish, without extra charge, the necessary test pieces and samples, including facilities and labor for obtaining the same, as requested by the ENGINEER. When required, the CONTRACTOR shall furnish certificates of tests of materials and equipment made at the point of manufacture by a recognized testing laboratory.

The OWNER, ENGINEER, and authorized government agents, and their representatives shall at all times be Provided safe access to the work wherever it is in Preparation or Progress, and the CONTRACTOR shall Provide facilities for such access and for observations, including maintenance of temporary and permanent access.

If the Specifications, laws, ordinances, or any public authority require any work, to be specially tested or approved, the CONTRACTOR shall give timely notice of its readiness for observations. If any work should be covered up without approval or consent of the ENGINEER, it shall, if required by the ENGINEER, be uncovered for examination at the CONTRACTOR's expense.

Reexamination of questioned work may be ordered by the ENGINEER, and, if so ordered, the work shall be uncovered by the CONTRACTOR. If such work is found to be in accordance with the Contract Documents, the OWNER will pay the cost of uncovering, exposure, observation, inspection, testing and reconstruction. If such work is found to be not in accordance with the Contract Documents, the CONTRACTOR shall correct the defective work, and the cost of reexamination and correction of the defective work shall be paid by the CONTRACTOR.

49. ROYALTIES AND PATENTS

The CONTRACTOR shall pay all royalty and licenses fees, unless otherwise specified. The CONTRACTOR shall defend all suits or claims for infringement of any patent rights and shall save the OWNER and the ENGINEER harmless from any and all loss, including reasonable attorneys' fees, on account thereof.

50. CONTRACTOR'S RIGHT TO TERMINATE CONTRACT

If the work should be stopped under an order of any court or other public authority for a period of more than 3 months, through no act or fault of the CONTRACTOR, its SUBCONTRACTORS, or respective employees or if the ENGINEER

should fail to make recommendation for payment to the OWNER or return payment request to CONTRACTOR for revision within 30 days after it is due, or if the OWNER should fail to pay the CONTRACTOR within 30 days after time specified in Article PARTIAL PAYMENTS, any sum recommended by the ENGINEER, then the CONTRACTOR may, upon 15 days' written notice to the OWNER and the ENGINEER, stop work or terminate this Contract and recover from the OWNER payment for all acceptable work performed and reasonable termination expenses, unless said default has been remedied.

51. CORRECTION OF DEFECTIVE WORK DURING WARRANTY PERIOD

The CONTRACTOR hereby agrees to make, at their own expense, all repairs or replacements necessitated by defects in materials or workmanship, Provided under terms of this Contract, and pay for any damage to other works resulting from such defects, which become evident within 2 years after the date of final acceptance of the work or within 2 years after the date of substantial completion established by the ENGINEER for specified items of equipment, or within such longer period as may be Prescribed by law or by the terms of any applicable special guarantee required by the Contract Documents. Un-remedied defects identified for correction during the warranty period but remaining after its expiration shall be considered as part of the obligations of the warranty. Defects in material, workmanship, or equipment which are remedied as a result of obligations of the warranty shall subject the remedied portion of the work to an extended warranty period of 2 years after the defect has been remedied.

The CONTRACTOR further assumes responsibility for a similar guarantee for all work and materials provided by SUBCONTRACTORS or manufacturers of packaged equipment components. The effective date for the start of the guarantee or warranty period for equipment qualifying as substantially complete is defined in Article SUBSTANTIAL COMPLETION, AND Article SUBSTANTIAL COMPLETION DATE, in these General Conditions.

The CONTRACTOR also agrees to hold the OWNER and the ENGINEER harmless from liability of any kind arising from damage due to said defects. The CONTRACTOR shall make all repairs and replacements promptly upon receipt of written order for same from the OWNER. If the CONTRACTOR fails to make the repairs and replacements promptly, or in an emergency where delay would cause serious risk, or loss, or damage, the OWNER may have the defective work corrected or the rejected work removed and replaced, and the CONTRACTOR and their Surety shall be liable for the cost thereof.

PROGRESS OF THE WORK

52. BEGINNING OF THE WORK

Following execution of the Contract, the CONTRACTOR shall meet with the OWNER and ENGINEER relative to their arrangements for prosecuting the work.

53. SCHEDULES AND PROGRESS REPORTS

Prior to starting the construction, the CONTRACTOR shall Prepare and submit to the ENGINEER, a Progress schedule showing the dates on which each part or division of the work is expected to be started and finished, and a Preliminary schedule for submittals. The Progress schedule for submittals shall be brought up to date and submitted to the ENGINEER at the end of each month or at such other times the ENGINEER may request.

The CONTRACTOR shall forward to the ENGINEER, at the end of each month, an itemized report of the delivery status of major and critical items of purchased equipment and material, including shop drawings and the status of shop and field fabricated work. These Progress reports shall indicate the date of the purchase order, the current percentage of completion, estimated delivery, and cause of delay, if any.

If the completion of any part of the work or the delivery of materials is behind the submitted Progress schedule, the CONTRACTOR shall submit in writing a plan acceptable to the OWNER and ENGINEER for bringing the work up to schedule.

The OWNER shall have the right to withhold Progress payments for the work if the CONTRACTOR fails to update and submit the Progress schedule and reports as specified.

54. PROSECUTION OF THE WORK

It is expressly understood and agreed that the time of beginning, rate of Progress, and time of completion of the work are the essence of this Contract. The work shall be prosecuted at such time, and in or on such part or parts of the Project as may be required, to complete the Project as contemplated in the Contract Documents and the Progress schedule.

If the CONTRACTOR desires to carry on work at night or outside the regular hours, he shall give timely notice to the ENGINEER to allow satisfactory arrangements to be made for observing the work in Progress.

55. OWNER'S RIGHT TO RETAIN IMPERFECT WORK

If any part or portion of the work completed under this Contract shall Prove defective and not in accordance with the Drawings and Specifications, and if the imperfection in the same shall not be of sufficient magnitude or importance as to make the work dangerous or unsuitable, or if the removal of such work will create conditions which are dangerous or undesirable, the OWNER shall have the right and authority to retain such work but will make such deductions in the final payment therefore as may be just and reasonable.

56. OWNER'S RIGHT TO DO WORK

Should the CONTRACTOR neglect to Prosecute the work in conformance with the Contract Documents or neglect or refuse at their own cost to remove and replace work rejected by the ENGINEER, then the OWNER may notify the Surety of the condition, and after 10 days' written notice to the CONTRACTOR and the Surety, or without notice if an emergency or danger to the work or public exists, and without Prejudice to any other right which the OWNER may have under Contract, or otherwise, take over that portion of the work which has been improperly or non-timely executed, and make good the deficiencies and deduct the cost thereof from the payments then or thereafter due the CONTRACTOR.

57. OWNER'S RIGHT TO TRANSFER EMPLOYMENT

If the CONTRACTOR should abandon the work or if he should persistently or repeatedly refuse or should fail to make prompt payment to SUBCONTRACTORS for material or labor, or to persistently disregard laws, ordinances, or to prosecute the work in conformance with the Contract Documents, or otherwise be guilty of a substantial violation of any Provision of the Contract or any laws or ordinance, then the OWNER may, without Prejudice to any other right or remedy, and after giving the CONTRACTOR and Surety 10 days' written notice, transfer the employment for said work from the CONTRACTOR to the Surety. Upon receipt of such notice, such Surety shall enter upon the Premises and take possession of all materials, tools, and appliances thereon for the purpose of completing the work included under this contract and employ by Contract or otherwise, any qualified person or persons to finish the work and Provide the materials therefore, in accordance with the Contract Documents, without termination of the continuing full force and effect of this contract. In case of such transfer of employment to such Surety, the Surety shall be paid in its own name on estimates according to the terms hereof without any right of the CONTRACTOR to make any claim for the same or any part thereof.

If, after the furnishing of said written notice to the Surety, the CONTRACTOR and the Surety still fail to make reasonable Progress on the performance of the work, the OWNER may terminate the employment of the CONTRACTOR and take possession of the Premises and of all materials, tools, and appliances thereon and finish the work by whatever method he may deem expedient and charge the cost thereof to the CONTRACTOR and the Surety. In such case, the CONTRACTOR shall not be entitled to receive any further payment until the work is finished. If the expense of completing the Contract, including compensation for additional managerial and administrative services, shall exceed such unpaid balance, the CONTRACTOR and the Surety shall pay the difference to the OWNER.

A. TERMINATION FOR CONVENIENCE AND RIGHT OF SUSPENSION

Owner shall have the right to terminate this Contract without cause by written notice of Termination to the Contractor. In the event of such termination for convenience, the Contractor's recovery against the Owner shall be limited to that portion of the Contract amount earned through the date of termination, together with any retainage withheld and reasonable termination expenses incurred. Contractor shall not be entitled to any other or further recovery against the Owner, including, but not limited to, damages or any anticipated profit on portions of the Work not performed.

The Owner shall have the right to suspend all or any portions of the Work upon giving the Contractor prior written notice of such suspension. If all or any portion of the Work is so suspended, the Contractor shall be entitled to reasonable costs, expenses and time extension associated with the suspension.

58. DELAYS AND EXTENSION OF TIME

If the CONTRACTOR is delayed in the Progress of the work by any act or neglect of the OWNER or the ENGINEER, or by any separate CONTRACTOR employed by the OWNER, or by strikes, lockouts, fire, adverse weather conditions not reasonably anticipated, or acts of Nature, and if the CONTRACTOR, within 48 hours of the start of the occurrence, gives written notice to the OWNER of the cause of the potential delay and estimate of the possible time extension involved, and within 10 days after the cause of the delay has been remedied, the CONTRACTOR gives written notice to the OWNER of any actual time extension requested as a result of the aforementioned occurrence, then the Contract time may be extended by change order for such reasonable time as the ENGINEER determines. It is agreed that no claim shall be made or allowed for any damages, loss, or expense which may arise out of any delay caused by the above referenced acts or occurrences other than claims for the appropriate extension of time. No extension of time will be granted to the CONTRACTOR for delays occurring to parts of the work that have no measurable impact on the completion of the total work under this Contract. No extension of time will be considered for weather conditions reasonably anticipated for the area in which the work is being performed. Reasonably anticipated weather conditions will be based on official records of monthly Precipitation and other historical data. Adverse weather conditions, if determined to be of a severity that would impact Progress of the work, may be considered as cause for an extension of Contract completion time.

Delays in delivery of equipment or material purchased by the CONTRACTOR or their SUBCONTRACTORS, including OWNER-selected equipment shall not be considered as a just cause for delay, unless the OWNER determines that for good cause the delay is beyond the control of the CONTRACTOR. The CONTRACTOR shall be fully responsible for the timely ordering, scheduling, complete the work is the per-diem rate, as stipulated in the Bid. The said amount is hereby agreed upon as a reasonable estimate of the costs, which may be accrued by the OWNER after the expiration of the time of completion. It is expressly understood and agreed that this amount is not to be considered in the nature of a penalty, but as liquidated damages which have accrued against the CONTRACTOR. The OWNER shall have the right to deduct such damages from any amount due, or that may become due the CONTRACTOR, or the amount of such damages shall be due and collectible from the CONTRACTOR or Surety.

59. DIFFERING SITE CONDITIONS

The CONTRACTOR shall promptly, and before the conditions are disturbed, give a written notice to the OWNER and ENGINEER of:

- 1) subsurface or latent physical conditions at the site which differ materially from those indicated in this contract,
- 2) unknown physical conditions at the site, of an unusual nature, which differ materially from those ordinarily encountered and generally recognized as inherent in work of the character provided for in the Contract.

The ENGINEER will investigate the site conditions promptly after receiving the notice. If the conditions do materially

so differ and cause an increase or decrease in the CONTRACTOR's cost of, or the time required for, performing any part of the work under this Contract, whether or not changed as a result of the conditions, and equitable adjustment shall be made under this Article and the Contract modified in writing accordingly.

No request by the CONTRACTOR for an equitable adjustment to the Contract under this Article will be allowed, unless the CONTRACTOR has given the written notice required; provided that the time prescribed above for giving written notice may be extended by the OWNER.

No request by the CONTRACTOR for an equitable adjustment to the Contract for differing site conditions will be allowed if made after final payment under this Contract.

60. LIQUIDATED DAMAGES

Should the Contractor fail to complete the work or any part thereof in the time agreed upon in the Contract Documents or within such extra time as may have been allowed for delays by extensions granted as provided in the Contract, the Contractor shall reimburse the Owner for the additional expense and damage for each calendar day that project outlined in Contract Documents remains uncompleted after the completion date. Liquidated damages shall be assessed. It is agreed that the amount of such additional expense and damage incurred by reason of failure to complete the work is the per diem rate as stipulated in the Bid. The said amount is hereby agreed upon as a reasonable estimate of the costs which may be accrued by the Owner after the expiration of the time of completion. It is expressly understood and agreed that this amount is not to be considered in the nature of a penalty but as liquidated damages, which have accrued against the Contractor. The Owner shall have the right to deduct such damages from any amount due or that may become due the Contractor or the amount of such damages shall be due and collectible from the Contractor.

61. OTHER CONTRACTS

The OWNER reserves the right to let other Contracts in connection with the work. The CONTRACTOR shall afford other CONTRACTORS reasonable opportunity for the introduction and storage of their materials and the execution of their work and shall properly connect and coordinate their work with theirs.

If any part of the work under this Contract depends for Proper execution or results upon the work of any other CONTRACTOR, utility service company or OWNER, the CONTRACTOR shall inspect and Promptly report to the ENGINEER in writing any patent or apparent defects to deficiencies in such work that render it unsuitable for such Proper execution and results. The CONTRACTOR's failure to so report shall constitute and acceptance of the work by others as being fit and Proper for integration with work under this Contract, except for latent or non-apparent defects and deficiencies in the work.

62. USE OF PREMISES

The CONTRACTOR shall confine their equipment, the storage of materials and the operation of their workers to limits shown on the Drawings or indicated by law, ordinances, permits, or directions of the ENGINEER, and shall not unreasonably encumber the Premises with their materials. The CONTRACTOR shall provide, at their own expense, the necessary rights-of-way and access to the work, which may be required outside the limits of the OWNER's Property and shall furnish the ENGINEER copies of permits and agreements for use of the Property outside that provided by the OWNER.

The CONTRACTOR shall not load nor permit any part of the structure to be loaded in any manner that will endanger the structure, nor shall CONTRACTOR subject any part of the work or adjacent Property to stresses or Pressures that will endanger it.

63. SUBSTANTIAL COMPLETION DATE

The ENGINEER may issue a written notice of substantial completion for the purpose of establishing the starting date for specific equipment guarantees, and to establish the date that the OWNER will assume the responsibility for the cost

of operating such equipment. Said notice shall not be considered as final acceptance of any portion of the work or relieve the CONTRACTOR from completing the remaining work within the specified time and in full compliance with the Contract Documents. See SUBSTANTIAL COMPLETION under DEFINITIONS of these General Conditions.

64. PERFORMANCE TESTING

Operating equipment and systems shall be performance tested in the Presence of the ENGINEER to demonstrate compliance with the specified requirements. Performance testing shall be conducted under the specified design operating conditions or under such simulated operating conditions as recommended or approved by the ENGINEER. Schedule such testing with the ENGINEER at least one week in advance of the planned date for testing.

65. OWNER'S USE OF PORTIONS OF THE WORK

Following issuance of the written notice of Substantial Completion, the OWNER may initiate operation of the facility. Such use shall not be considered as final acceptance of any portion of the work, nor shall such use be considered as cause for an extension of the Contract completion time, unless authorized by a Change Order issued by the OWNER.

66. CUTTING AND PATCHING

The CONTRACTOR shall do all cutting, fitting, or patching of their work that may be required to make its several parts come together Properly and fit it to receive or be received by work of other CONTRACTORS shown upon or reasonably implied by the Drawings.

67. CLEANING UP

The CONTRACTOR shall, at all times, keep Property on which work is in Progress and the adjacent Property free from accumulations of waste material or rubbish caused by employees or by the work. Upon completion of the construction, the CONTRACTOR shall remove all temporary structures, rubbish, and waste materials resulting from their operations.

PAYMENT

68. PAYMENT FOR CHANGE ORDERS

The OWNER's request for quotations on alterations to the work shall not be considered authorization to proceed with the work expediting, delivery, and installation of all equipment and materials. Within a reasonable period after the CONTRACTOR submits to the OWNER a written request for an extension of time, the ENGINEER will Present their written opinion to the OWNER as to whether an extension of time is justified, and, if so, their recommendation as to the number of days for time extension. The OWNER will make the final decision on all requests for extension of time.

Prior to the issuance of a formal Change Order, nor shall such request justify any delay in existing work. Quotations for alterations to the work shall include substantiating documentation with an itemized breakdown of CONTRACTOR and SUBCONTRACTOR costs, including labor, material, rentals, approved services, overhead, and profit. OWNER may require detailed cost data in order to substantiate the reasonableness of the proposed costs.

Any compensation paid in conjunction with the terms of a Change Order shall comprise total compensation due the CONTRACTOR for the work or alteration defined in the Change Order. By signing the Change Order, the CONTRACTOR acknowledges that the stipulated compensation includes payment for the work or alteration plus all payment for the interruption of schedules, extended overhead, delay, or any other impact claim or ripple effect, and by such signing specifically waives any reservation or claim for additional compensation in respect to the subject Change Order.

At the OWNER's option, payment or credit for any alterations covered by a Change Order shall be determined by one or a combination of the methods set forth in A, B, or C below, as applicable:

A. UNIT PRICES

Those unit Prices stipulated in the Bid shall be utilized where they are applicable. In the event the Change Order results in a change in the original quantity that is materially and significantly different from the original bid quantity, a new unit Price shall be negotiated upon demand of either party. Unit Prices for new items included in the Change Order shall be negotiated and mutually agreed upon.

B. LUMP SUM

A total lump sum for the work negotiated and mutually acceptable to the CONTRACTOR and the OWNER. Lump sum quotations for modifications to the work shall include substantiating documentation with an itemized breakdown of CONTRACTOR and SUBCONTRACTOR costs, including labor, material, rentals, approved services, overhead, and Profit, all calculated as specified under "C" below.

C. COST REIMBURSEMENT WORK

The term "cost reimbursement" shall be understood to mean that payment for the work will be made on a time and expense basis, that is, on an accounting of the CONTRACTOR's forces, materials, equipment, and other items of cost as required and used to do the work.

If the method of payment cannot be agreed upon Prior to the beginning of the work, and the OWNER directs by written Change Order that the work be done on a cost reimbursement basis, then the CONTRACTOR shall furnish labor, and furnish and install equipment and materials necessary to complete the work in a satisfactory manner and within a reasonable period of time. For the work performed, payment will be made for the documented actual cost of the following:

1. Labor including foremen for those hours they are assigned and participating in the cost reimbursement work (actual payroll cost, including wages, fringe benefits as established by negotiated labor agreements, labor insurance, and labor taxes as established by law). No other fixed labor burdens will be considered, unless approved in writing by the OWNER.
2. Material delivered and used on the designated work, including sales tax, if paid by the CONTRACTOR or their SUBCONTRACTOR.
3. Rental or equivalent rental cost of equipment, including necessary transportation for items having a value in excess of \$100. Rental or equivalent rental cost will be allowed for only those days or hours during which the equipment is in actual use. Rental and transportation allowances shall not exceed the current rental rates prevailing in the locality. The rentals allowed for equipment will, in all cases, be understood to cover all fuel, supplies, repairs, and renewals, and no further allowances will be made for those items, unless specific agreement to that effect is made.
4. Additional bond, as required and approved by the OWNER.
5. Additional insurance (other than labor insurance) as required and approved by the OWNER.

In addition to 1 through 5 above, an added fixed fee of 15 percent (%) for general overhead & profit shall be allowed for the CONTRACTOR (or approved SUBCONTRACTOR) executing the Cost Reimbursement work.

An additional fixed fee of 5% will be allowed the CONTRACTOR for the administrative handling of portions of the work that are executed by an approved SUBCONTRACTOR. No additional fixed fee will be allowed for the administrative handling of work executed by the SUBCONTRACTOR of a SUBCONTRACTOR.

The added fixed fees shall be considered to be full compensation, covering the cost of general supervision, overhead, Profit, and any other general expense. The CONTRACTOR's records shall make clear distinction between the direct costs of work paid for on a cost reimbursement basis and the costs of other work. The CONTRACTOR shall furnish

the ENGINEER report sheets in duplicate of each day's cost reimbursement work no later than the working day following the performance of said work. The daily report sheets shall itemize the materials used and shall cover the direct cost of labor and the charges for equipment rental, whether furnished by the CONTRACTOR, SUBCONTRACTOR or other forces. The daily report sheets shall provide names or identifications and classifications of workers, the hourly rate of pay and hours worked, and also the size, type, and identification number of equipment and hours operated.

Material charges shall be substantiated by valid copies of vendors' invoices. Such invoices shall be submitted with the daily report sheets, or, if not available, they shall be submitted with subsequent daily report sheets. Said daily report sheets shall be signed by the CONTRACTOR or their authorized agent.

The OWNER reserves the right to furnish such materials and equipment as he deems expedient and the CONTRACTOR shall have no claim for profit or added fees on the cost of such materials and equipment. To receive partial payments and final payment for cost reimbursement work, the CONTRACTOR shall submit to the ENGINEER, detailed and complete documented verification of the CONTRACTOR's and any of their SUBCONTRACTORS' actual costs involved in the cost reimbursement work. Such costs shall be submitted within 30 days after said work has been performed.

69. PARTIAL PAYMENTS

A. GENERAL

Nothing in this Article shall be construed to affect the right, hereby reserved, to reject the whole or any part of the aforesaid work, should such work be later found not to comply with the Provisions of the Contract Documents. All estimated quantities of work for which partial payments have been made are subject to review and correction on the final estimate. Payment by the OWNER and acceptance by the CONTRACTOR of partial payments based on periodic estimates of quantities of work performed shall not, in any way, constitute acceptance of the estimated quantities used as a basis for computing the amounts of the partial payments.

B. ESTIMATE

No more than once each month the Contractor shall submit to the ENGINEER a detailed estimate of the amount earned during the preceding month for the separate portions of the work and request payment. As used in this Article the words "amount earned" means the value, on the date of the estimate, for partial payment of the work completed in accordance with the Contract Documents and the value of approved materials delivered to the project site suitably stored and protected prior to incorporation into the work. Payment will be made by the Owner to the Contractor within 40 days receipt of the written recommendation of payment from the ENGINEER. Payment will be made by the Owner to the Contractor within 40 days receipt of the written recommendation of payment from the ENGINEER.

ENGINEER will, within 7 days after receipt of each request for payment, either indicate in writing a recommendation of payment and present the request to OWNER or return the request to CONTRACTOR indicating in writing ENGINEER's reasons for refusing to recommend payment. In the latter case, CONTRACTOR may, within 7 days, make the necessary corrections and resubmit the request.

ENGINEER may refuse to recommend the whole or any part of any payment if, in their opinion, it would be incorrect to make such representations to OWNER. ENGINEER may also refuse to recommend any such payment, or, because of subsequently discovered evidence or the results of subsequent inspections or tests, nullify any such payment previously recommended to such an extent as may be necessary in ENGINEER's opinion to protect the OWNER from loss because:

1. The work is defective, or completed work has been damaged requiring correction or replacement;
2. Written claims have been made against OWNER or Liens have been filed in connection with the work;

3. The Contract Price has been reduced because of Change Orders;
4. OWNER has been required to correct defective work or complete the work in accordance with Article OWNER'S RIGHT TO DO WORK;
5. Of CONTRACTOR's unsatisfactory Prosecution of the work in accordance with the Contract Documents; or
6. CONTRACTOR's failure to make payment to SUBCONTRACTORS or for labor, materials, or equipment.

C. DEDUCTION FROM ESTIMATE

Unless modified in the Supplementary Conditions, deductions from the estimate will be as described below:

1. The OWNER will deduct from the estimate, and retain as part security, 10 percent of the amount earned for work satisfactorily completed. A deduction and retainage of 10 percent will be made on the estimated amount earned for approved items of material delivered to and properly stored at the jobsite but not incorporated into the work. When the work is 90 percent complete, the OWNER may reduce the retainage to 5 percent of the dollar value of all work satisfactorily completed to date provided the CONTRACTOR is making satisfactory progress and there is no specific cause for a greater retainage. The OWNER may reinstate the retainage up to 10 percent if the OWNER determines, at their discretion, that the CONTRACTOR is not making satisfactory progress or where there is other specific cause for such withholding.

D. QUALIFICATION FOR PARTIAL PAYMENT FOR MATERIALS DELIVERED

Unless modified in the Supplementary Conditions, qualification for partial payment for materials delivered but not yet incorporated into the work shall be as described below:

1. Materials, as used herein, shall be considered to be those items which are fabricated and manufactured material and equipment. No consideration shall be given to individual purchases of less than \$200 for any one item.
2. To receive partial payment for materials delivered to the site, but not incorporated in the work, it shall be necessary for the CONTRACTOR to include a list of such materials on the Partial Payment Request. At their sole discretion, the ENGINEER may approve items for which partial payment is to be made. Partial payment shall be based on the CONTRACTOR's actual cost for the materials as evidenced by invoices from the supplier. Proper storage and Protection shall be provided by the CONTRACTOR, and as approved by the ENGINEER. Final payment shall be made only for materials actually incorporated in the work and, upon acceptance of the work, all materials remaining for which advance payments had been made shall revert to the CONTRACTOR, unless otherwise agreed, and partial payments made for these items shall be deducted from the final payment for the work.
3. CONTRACTOR warrants and guarantees that title to all work, materials, and equipment covered by any Application for Payment, whether incorporated in the Project or not, will pass to OWNER at the time of payment free and clear of all liens, claims, security interests, and encumbrances.
4. If requested by the ENGINEER, the CONTRACTOR shall provide, with subsequent pay requests, invoices receipted by the supplier showing payment in full has been made.

E. PAYMENT

After deducting the retainage and the amount of all previous partial payments made to the Contractor from the amount earned the amount due will be made payable to the Contractor. Recommendations for payment received by the Owner less than 40 days prior to the scheduled day for payment will not be processed or paid until the following month.

70. CLAIMS FOR EXTRA WORK

In any case where the CONTRACTOR deems additional time or compensation will become due to them under this Contract for circumstances other than those defined in Article DELAYS AND EXTENSION OF TIME, the CONTRACTOR shall notify the ENGINEER, in writing, of their intention to make claim for such time or compensation before he begins the work on which he bases the claim, in order that such matters may be settled, if possible, or other appropriate action taken. The notice of claim shall be in duplicate, in writing, and shall state the circumstances and the reasons for the claim but need not state the amount. If such notification is not given or if the ENGINEER is not afforded proper facilities by the CONTRACTOR for keeping strict account of actual cost, then the CONTRACTOR hereby agrees to waive the claim for such additional time or compensation. Such notice by the CONTRACTOR, and fact that the ENGINEER has kept account of the cost as aforesaid, shall not in any way be construed as proving the validity of the claim.

No extension of time will be granted to the CONTRACTOR for delays resulting from extra work that have no measurable impact on the completion of the total work under this Contract. Claims for additional time or compensation shall be made in itemized detail and submitted, in writing, to the OWNER and ENGINEER within 10 days following completion of that portion of the work for which the CONTRACTOR bases their claim. Failure to make the claim for additional compensation in the manner and within the time specified above shall constitute waiver of that claim. In case the claim is found to be just, it shall be allowed and paid for as provided in Article PAYMENT FOR CHANGE ORDERS.

71. RELEASE OF LIENS OR CLAIMS

The CONTRACTOR shall indemnify and hold harmless the OWNER from all claims for labor and materials furnished under this Contract. Prior to the final payment, the CONTRACTOR shall furnish to the OWNER, as part of their final payment request, a certification that all of the CONTRACTOR's obligations on the project have been satisfied and that all monetary claims and indebtedness have been paid. The CONTRACTOR shall furnish complete and legal effective releases or waivers, satisfactory to the OWNER, of all liens arising out of or filed in connection with the work.

72. FINAL PAYMENT

Upon completion of the work the Contractor shall notify the ENGINEER, in writing, that he has completed it and shall request final payment. The Contractor shall be responsible for keeping an accurate and detailed record of their actual construction. Upon completion of construction and before final acceptance and payment the Contractor shall furnish the ENGINEER as-built drawings of their construction. Upon receipt of a request for final payment and the as-built drawings the ENGINEER will inspect and, if acceptable, submit to the Owner their recommendation as to acceptance of the completed work and as to the final estimate of the amount due the Contractor. Upon approval of this final estimate by the Owner and compliance by the Contractor with provisions in Article RELEASE OF LIENS OR CLAIMS, and other provisions as may be applicable, the Owner shall pay to the Contractor all monies due to them under the provisions of these Contract Documents.

A. Acceptance and Final Payment

Whenever the Contractor has completely performed the work provided for under the Contract and the ENGINEER has performed a final inspection and made final acceptance and subject to the terms of the ENGINEER will prepare a final estimate showing the value of the work as soon as the ENGINEER makes the necessary measurements and computations. The ENGINEER will correct all prior estimates and payments in the final estimate and payment. The OWNER will pay the estimate, less any sums that the OWNER may have deducted or retained under the provisions of the Contract, as soon as practicable after final acceptance of the work, provided the Contractor has met the requirements of (1) through (4) below.

1. The Contractor has agreed in writing to accept the balance due or refund the overpayment, as determined by the OWNER, as full settlement of their account under the Contract and of all claims in connection therewith, or the Contractor, accepted the balance due or refunded the overpayment,

as determined by the OWNER, with the stipulation that their acceptance of such payment or the making of such refund does not constitute any bar, admission, or estoppel, or have any effect as to those payments in dispute or the subject of a pending claim between the Contractor and the OWNER. To receive payment based on a FINAL PAYMENT CERTIFICATE, The Contractor further agrees, by submitting a FINAL PAYMENT CERTIFICATE that any pending or future arbitration claim or suit is limited to those particulars, including the itemized amounts, defined in the original FINAL PAYMENT CERTIFICATE , and that he will commence with any such arbitration claim or suit within 15 calendar days from and after the time of final PAYMENT of the work and that their failure to file a formal claim within this period constitutes their full acceptance of the ENGINEER's final estimate and payment. The overpayment refund check from the Contractor, if required, will be considered a part of any Acceptance Letter executed.

2. The Contractor has properly maintained the project, as specified hereinbefore.
3. The Contractor has furnished a sworn affidavit to the effect that the Contractor has paid all bills and no suits are pending (other than those exceptions listed, if any) in connection with work performed under the Contract and that the Contractor has not offered or made any gift or gratuity to, or made any financial transaction of any nature with, any employee of the OWNER in the performance of the Contract.
4. Final payment will not be released until the City receives Certified As-built drawings in Auto Cad & Adobe format as well as:

73. NO WAIVER OF RIGHTS

Neither the inspection by the OWNER, through the ENGINEER or any of their employees, nor any order by the OWNER for payment of money, nor any payment for, or acceptance of, the whole or any part of the work by the OWNER or ENGINEER, nor any extension of time, nor any possession taken by the OWNER or its employees, shall operate as a waiver of any Provision of this Contract, or any power herein reserved to the OWNER, or any right to damages herein Provided, nor shall any waiver of any breach in this Contract be held to be a waiver of any other or subsequent breach. Acceptance or final payment shall not be final and conclusive with regards to latent defects, fraud, or such gross mistakes as may amount to fraud, or as regards the OWNER's rights under the warranty.

74. ACCEPTANCE OF FINAL PAYMENT CONSTITUTES RELEASE

The acceptance by the CONTRACTOR of the final payment shall release the OWNER and the ENGINEER, as representatives of the OWNER, from all claims and all liability to the CONTRACTOR for all things done or furnished in connection with the work, and every act of the OWNER and others relating to or arising out of the work except claims Previously made in writing and still unsettled. No payment, however, final or otherwise, shall operate to release the CONTRACTOR or their Sureties from obligations under this Contract and the Performance Bond, Payment Bond, and other bonds and warranties, as herein provided.

SUPPLEMENTARY CONDITIONS

The General Conditions are hereby revised as follows:

END OF SECTION

PART 4

GENERAL REQUIREMENTS

SECTION 01001
GENERAL REQUIREMENTS

PART 1 - GENERAL

1.1 PROJECT DESCRIPTION

- A. A brief description of the work is stated in the Invitation to Bid. To determine the full scope of the project or of any part of the project, coordinate the applicable information in the several parts of these Contract Documents.

1.2 MOBILIZATION AND DEMOBILIZATION

- A. Contractor shall be responsible for mobilization and demobilization of labor, materials and equipment. Payment for mobilization and demobilization will be included in the lump sum price indicated in the BID. Parking for vehicles used on site will be determined by the ENGINEER prior to mobilization.
- B. DAILY REPORTS (If Required)
- 1) The CONTRACTOR shall submit daily reports of construction activities for each site, including non-work days. The report shall include:
 - a) Manpower, number of workers by craft
 - b) Quality Control
 - c) Equipment on the Project
 - d) Major deliveries
 - e) Activities worked
 - f) New problems
 - g) Other pertinent information
 - 2) A similar report shall be submitted for/by each Subcontractor.
 - 3) The reports shall be submitted to the ENGINEER upon request.

1.3 SCHEDULING

- A. Prior to starting the work, confer with the ENGINEER and Owner's representative to develop an approved work schedule. Which will permit the surrounding facilities to function as normally as practical. It may be necessary to do certain parts of the work outside normal working hours to avoid undesirable conditions. The Contractor shall do this work at such times and at no additional cost to the Owner.
- B. SPECIAL EVENTS: Contractor may be asked to stop work during special events.

1.4 COORDINATION

- A. Contractors shall cooperate in the coordination of their separate activities in a manner that will provide the least interference with the Owner's operations and other contractors and utility companies working in the area, and in the interfacing and connection of the separate elements of the overall project work.
- B. If any difficulty or dispute should arise in the accomplishment of the above, the problem shall be brought immediately to the attention of the ENGINEER.

- C. CONTRACTOR shall notify all residents and proprietors adjacent to construction site of work to be performed, more specifically the notice shall state the day and time construction will begin, the name and phone number of the Contractor's representative responsible for the completion of the proposed improvements. Notice shall also include the Owner's representative for the project.

1.5 SITE INVESTIGATION AND REPRESENTATION

- A. The Contractor acknowledges satisfaction as to the nature and location of the work, the general and local conditions, particularly those bearing upon availability of transportation, access to the site, disposal, handling and storage of materials, availability of labor, water, electric power, roads, and uncertainties of weather, or similar physical conditions at the site, the conformation and conditions at the site, the character of equipment and facilities needed preliminary to and during the prosecution of the work, and all other matters which can any way affect the work or the cost thereof under this Contract.
- B. The Contractor further acknowledges satisfaction as to character, quality, and quantity of surface and subsurface materials to be encountered from their inspection of the site and from reviewing any available records of exploratory work furnished by the Owner or included in these Documents. Failure by the Contractor to become acquainted with the physical conditions of the site and all available information will not relieve the Contractor from responsibility for properly estimating the difficulty or cost of successfully performing the work.
- C. The Contractor warrants that as a result of examination and investigation of all the aforesaid data, the contractor can perform the work in a good and workmanlike manner and to the satisfaction of the Owner.
- D. The Owner assumes no responsibility for any representations made by any of its officers or agents during or prior to the execution of this Contract, unless (1) such representations are expressly stated in the Contract, and (2) the Contract expressly provides that the responsibility therefore is assumed by the Owner.

1.6 INFORMATION ON SITE CONDITIONS

- A. General: Any information obtained by the ENGINEER regarding site conditions, subsurface information, water level, existing construction of site facilities as applicable, and similar data will be available for inspection at the office of the ENGINEER upon request. Such information is offered as supplementary information only. Neither the ENGINEER nor the Owner assumes any responsibility for the completeness or interpretation of such supplementary information.
- B. The Contractor shall provide a color audio-video recording showing the entire preconstruction site. All videos shall be taken by a professional commercial video photographer. The video photographer shall be an established enterprise that routinely provides these services. The videos shall be in DVD format or .wav files on removable USB drive, indicating the date, project name, and a brief description of the location where the video was taken. The Contractor shall submit one (1) copy of the preconstruction audio-video to the OWNER.

1.7 DIFFERING SUBSURFACE CONDITIONS

- A. The ENGINEER shall investigate such conditions promptly and following this investigation, the Contractor shall proceed with the work, unless otherwise instructed by the ENGINEER. If the ENGINEER finds that such conditions do so materially differ and cause an increase or decrease in the cost of, or in the time required for performing the work, the ENGINEER will recommend to the Owner the amount of adjustment in cost and time he considers reasonable. The Owner will make the final decision on all Change Orders to the Contract regarding any adjustment in cost or time for completion.

1.8 UTILITIES

- A. During excavation, the Contractor shall be responsible for determining, at their cost, the locations of all known utilities in the project area.
- B. Contractor shall notify utility location service (e.g. Call Sunshine 1-800-432-4770) a minimum for 48 hours prior to work order mobilization. Assigned notification number shall be maintained at the job site at all times and recorded in the daily reports.

1.9 CONTRACTOR'S RESPONSIBILITY FOR UTILITY PROPERTIES AND SERVICE

- A. Where the Contractor's operations could cause damage or inconvenience to telephone, television, gas, water, sewer, or irrigation systems, the operations shall be suspended until all arrangements necessary for the protection of these utilities and services have been made by the Contractor.
- B. Notify all utility offices, which are affected by the construction operation at least 48 hours in advance. Under no circumstances expose any utility without first obtaining permission from the appropriate agency. Once permission has been granted, locate, expose, and provide temporary support for all existing underground utilities.
- C. The Contractor shall be solely and directly responsible to the Owner and operators of such properties for any damage, injury, expense, loss, inconvenience, delay, suits, actions, or claims of any character brought because of any injuries or damage which may result from the construction operations under this Contract
- D. Neither the Owner nor its Officers or agents shall be responsible to the Contractor for damages as a result of the Contractor's failure to protect utilities encountered in the work.
- E. In the event of interruption to domestic water, sewer, storm drain, or other utility services as a result of accidental breakage due to construction operations, promptly notify the proper authority. Cooperate with said authority in restoration of service as promptly as possible and bear all costs of repair. In no case shall interruption of any water or utility service be allowed to exist outside working hours unless prior approval is granted.
- F. In the event the Contractor encounters water service lines that interfere with trenching, he may, by obtaining prior approval of the property owner, Florida Keys Aqueduct Authority

(FKAA), or Fire Department as applicable, and the ENGINEER, cut the service dig through, and restore service with similar and equal materials at the Contractor's expense.

- G. The Contractor shall replace, at their own expense, all existing utilities or structures removed or damaged during construction, unless otherwise provided for in these Contract Documents or ordered by the ENGINEER.

1.10 TEMPORARY WATER

- A. The Contractor shall make their own arrangements to obtain suitable water for any need and shall pay all costs.

1.11 TEMPORARY ELECTRIC POWER

- A. The Contractor shall make their own arrangements to obtain and pay for electrical power used until final acceptance by the Owner.

1.12 SAFETY REQUIREMENTS FOR TEMPORARY ELECTRIC POWER

- A. Temporary electric power installation shall meet the construction Safety requirements of OSHA, State, and other governing agencies.

1.13 SANITARY FACILITIES

- A. The Contractor shall provide and maintain sanitary facilities for their employees and their subcontractor's employees that will comply with the regulations of the local and State Departments of Health and as directed by the Owner.

1.14 STORAGE OF MATERIALS

- A. Materials shall be so stored as to ensure the preservation of their quality and fitness for the work. When considered necessary, they shall be placed on wooden platforms or other clean hard surfaces and not on the ground. Stored materials shall be located so as to facilitate prompt inspection. Stored materials on city property must be safe and secured from the general public and if necessary they must be fitted with lights at night. Private property shall not be used for storage purposes without the written permission of the owner or lessee. Materials shall not be stored where access to any structure, plot, or road is blocked. Location of stored materials approved by the ENGINEER or their designee.
- B. Delicate instruments and materials subject to vandalism shall be placed under lock cover and, if necessary, provided with temperature control as recommended by the manufacturer.

1.15 CONSTRUCTION SAFETY PROGRAM

- A. The Contractor shall develop and maintain for the duration of their Contract, a safety program that will effectively incorporate and implement all required safety provisions. The Contractor shall appoint an employee who is qualified and authorized to supervise and enforce compliance with the safety program.
- B. The duty of the ENGINEER to conduct construction review of the Contractor's performance is not intended to include a review or approval of the adequacy of the Contractor's safety

supervisor, the safety program or any safety measures taken in, on, or near the construction site.

- C. The Contractor shall do all work necessary to protect the public from hazards, including, but not limited to, surface irregularities, or unramped grade changes on pedestrian walkways and docks. Barricades, lights, and proper signs shall be furnished in sufficient amount to safeguard the public and the work.
- D. The performance of all work shall be in accordance with the applicable governing safety authorities.

1.16 ACCIDENT REPORTS

- A. If death or serious injuries or serious damages are caused; the Contractor must promptly report by telephone or messenger to the ENGINEER. In addition, the Contractor must promptly report in writing to the ENGINEER all accidents whatsoever arising out of or in connection with, the performance of the work whether on, or adjacent, to the site, giving full details and statements of witnesses.
- B. If a claim is made against the Contractor or any subcontractor on account of any accident, the Contractor shall promptly report the facts in writing to the ENGINEER, giving full details of the claim.

1.17 FIRE PREVENTION AND PROTECTION

- A. The Contractor shall perform all work in a fire-safe manner and shall supply and maintain on the site adequate fire-fighting equipment capable of extinguishing incipient fires. The Contractor shall comply with applicable federal, state, and local fire-prevention regulations. Where these regulations do not apply, applicable parts of the National Fire Prevention Standard for Safeguarding Building Construction Operations (NFPA No. 241) shall be followed.

1.18 SITE RESTORATION AND CLEANUP:

- A. At all times during the work keep the premises clean and orderly and upon completion of daily work repair all damage caused by equipment and leave the project free of rubbish or excess materials of any kind.
- B. Stockpile excavated materials in a manner that will cause the least damage to adjacent lawns, grassed areas, gardens, shrubbery, or fences regardless of whether these are on private property, or State, County, or City rights-of-way. Remove all excavated materials from grassed and planted areas, and leave these surfaces in a condition equivalent to their original condition.

1.19 FINISHING OF SITE AND STORAGE AREAS

- A. Upon completion of the project, all areas used by the Contractor shall be properly cleared of all temporary structures, rubbish and waste materials and properly graded to drain and blend in with the abutting property. Areas used for the deposit of waste materials shall be finished to properly drain and blend in with the surrounding terrain.

1.20 AREA CLEANUP DURING CONSTRUCTION

- A. Thoroughly clean all spilled dirt, gravel, sand or other foreign materials caused by the construction operations from all streets and roads, grass, pathways, docks or concrete walkways and from adjacent areas at the conclusion of each day's operation. Truck or equipment wash down is not to be performed on City Property.

1.21 PREVENTION

- A. Applicable environmental regulations shall be strictly adhered to.

1.22 SUBMITTALS

- A. See Submittals section of the specifications

1.23 PAYMENT

- A. The cost of the work in this section is considered incidental to the contract.

END OF SECTION

SECTION 01010
SCOPE OF WORK

1.1 DESCRIPTION

Repair of the Cable Huts at Mallory Square that included the roof and concrete walls.

A. **ITB # 21-001 / CABLE HUTS STABILIZATION AND REPAIR**

1. Related requirements in other parts of the Contract Documents: Include but not limited to:
 - i. General and Supplementary Conditions of the Contract for Construction.

1.2 CONTRACTOR'S DUTIES:

- A. In addition to provisions stipulated in other portions of the Contract Documents, the Contractor shall:
 1. Secure permits as necessary for proper execution and completion of the work.
 2. Contractor must indemnify the FDEP & TDC. All conditions of the permit must be adhered to by the contractor.
 3. Notify (in writing) all vendors, residents and proprietors adjacent to construction site of work to be performed, more specifically the notice shall state the day and time construction will begin, hours of work, the name and phone number of the Contractor's Superintendent and an end date for the project.
- B. The Contractor shall be totally responsible for securing and complying with all, required permits and payment of associated fees. Contractor shall ensure that construction complies with all applicable local, state, and federal codes.
- C. Provide an experienced, qualified, and competent Superintendent able to read, write and speak English to oversee the work and perform quality assurance inspections. Prior to starting construction, the proposed Superintendent's qualifications shall be submitted in writing to the City for approval. The approved Superintendent shall be expected to remain for the duration of the Project, unless the City or ENGINEER deem him/her inadequate and requests his/her removal or the Contractor cannot continue their services to the Project for a reason or reasons that shall be communicated in writing to the City.
- D. The Superintendent shall provide to the City, upon request, Construction Reports for each week of construction, the reports shall be in English, legible, and signed. Contractor, upon request, shall provide PDF copies monthly. Reports shall include quantity control checks.
- E. It shall be the Contractor's responsibility to comply with the City's Ordinance

Chapter 26 Environment, Article IV. Sound Control below:

Sec. 26-193. - Exceptions.

- A. The prohibitions contained in this article shall not apply to the following:
 - 1. Construction/demolition. Sound levels produced from tools and equipment in commercial construction, demolition, drilling, or reasonably similar activities. However, such sound levels are limited to the hours of 8:00 a.m. to 7:00 p.m., Monday through Friday, and 9:00 a.m. to 5:00 p.m. on Saturday. The tools and equipment must be muffled and maintained equal to the functional standards of the industry. No exceptions contained in this subsection shall apply on Thanksgiving Day, Christmas Day and New Year's Day.
- B. The Contractor is responsible for the construction of the above mentioned project, concrete walkways and all associated items used in the completion of the project. Contractor is further responsible for all costs associated with the disposal of materials and must dispose of in an environmentally responsible manner.
- C. The Contractor shall provide material safety data sheets (2 copies) for chemicals, paints, coatings and materials used on-site prior to initiation of work.

1.3 CONTRACTOR'S USE OF PREMISES

- A. Work shall be scheduled as to not interfere with on-going area activities.
- B. Coordinate use of premises and requirements for security under direction of City.
- C. Assume full responsibility for the protection and safekeeping of products, under this Contract, stored on the site.
- D. Obtain and pay for the use of additional storage or work areas needed for operation.

1.4 MAINTENANCE OF EXISTING UTILITIES OPERATION

- A. Provide at least three weeks' notice prior to interruption of utility services for temporary or permanent connections.
- B. Keep interruption of utility services, and utility outages during disconnection, moving, and reconnection to a minimum.
- C. Keys Energy shall be notified two weeks in advance in writing by the contractor for any KEYS support equipment required by the Contractor during construction. Contractor is responsible for all impact fees. No additional payment will be paid for this coordination.

SECTION 01300
SUBMITTALS

PART 1 - GENERAL

1.1 GENERAL

- A. Inquiries: Direct to ENGINEER regarding procedure, purpose, or extent of Submittal.
- B. Submittal Submission Procedures: As provided in General Conditions, as specified herein, and as may otherwise be established during the preconstruction conference.
- C. OWNER's Authorization: At any time, OWNER may authorize changes to procedures and requirements for Submittals, as necessary to accomplish specific purpose of each Submittal. Such authorization will be by Field Order or Work Change Directive.
- D. Timeliness: Make submissions in accordance with requirements of individual Specification sections, as shown on the current accepted schedule of Submittals submissions, and in such sequence as to cause no delay in Work or in work of other contractors.
- E. Identification of Submittals:
 - 1. Complete, sign, and transmit with each Submittal package, one Transmittal of CONTRACTOR's Submittal Form.
 - 2. Identify each Submittal with numbering and tracking system reviewed by ENGINEER:
 - i. Sequentially number each Submittal.
 - ii. Resubmission of a Submittal will have original number with sequential alphabetic suffix.
 - 3. Show date of submission and dates of previous submissions.
 - 4. Show Project title and OWNER's contract identification and contract number.
 - 5. Show names of CONTRACTOR, Subcontractor or Supplier, and manufacturer as appropriate.
 - 6. Identify, as applicable, Contract Document section and paragraph to which Submittal applies.
 - 7. Clearly identify revisions from previous submissions.
- F. Incomplete Submittal Submissions:
 - 1. At ENGINEER's sole discretion, ENGINEER will either (i) return the entire Submittal for CONTRACTOR's revision/correction and resubmission, or (ii) retain portions of the Submittal and request submission/resubmission of specified items or as noted thereon.
 - 2. Submittals which do not clearly bear CONTRACTOR's specific written indication of CONTRACTOR review and approval of Submittal or which are transmitted with an unsigned or uncertified submission form or as may otherwise be required under Contract Documents, will be returned to CONTRACTOR unreviewed for resubmission in accordance with Contract Documents.
 - 3. Delays, re-sequencing or other impact to Work resulting from the CONTRACTOR's submission of unchecked or unreviewed, incomplete, inaccurate or erroneous, or

nonconforming Submittals, which will require CONTRACTOR's resubmission of a Submittal for ENGINEER's review, shall not constitute a basis of claim for adjustment in Contract Price or Contract Times.

- G. Non-specified Submissions: Submissions not required under these Contract Documents and not shown on schedule of Submittals submissions will not be reviewed and will be returned to CONTRACTOR.
- H. Transmit submittals in accordance with current accepted schedule of Submittal submissions, and deliver the ENGINEER designated by the ENGINEERING Department of the City of Key West.
- I. Disposition of Submittals: As specified herein for administrative Submittals. ENGINEER will review, stamp, and indicate requirements for resubmission or acceptance on Submittal as follows:
 - 1. No Exceptions Taken.
 - 2. Reviewed as Noted:
 - i. Reference the General Conditions for intent.
 - ii. CONTRACTOR may proceed to perform Submittal related Work.
 - iii. One copy for ENGINEER's file.
 - iv. One copy returned to CONTRACTOR.
 - 3. Revise and Resubmit (Revise/Correct or Develop Replacement and Resubmit):
 - i. Revise/correct in accordance with ENGINEER's comments and resubmit.
 - ii. One copy to ENGINEER's file.
 - iii. One copy returned to CONTRACTOR appropriately annotated.
 - 4. Payment for the work in this section will be incidental to the contract.

END OF SECTION

PART 5

CONSTRUCTION DRAWINGS

HISTORIC CABLE HUTS

EAST BUILDING & WEST BUILDING

WALL STREET, MALLORY SQUARE

KEY WEST FLORIDA

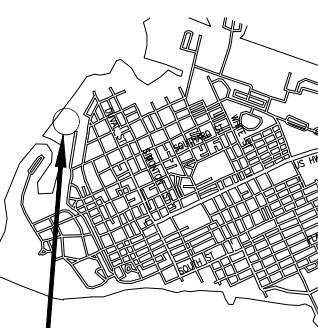
AERIAL PHOTO	SITE MAP - KEY WEST	PROJECT DIRECTORY	GENERAL NOTES																																																																																																																																												
 <p style="text-align: center;">SITE LOCATION Not to Scale</p>	 <p style="text-align: center;">SITE LOCATION WALL STREET, MALLORY SQUARE KEY WEST</p>	<p>PROJECT: HISTORIC CABLE HUTS EAST BUILDING AND WEST BUILDING MALLORY SQUARE, WALL STREET KEY WEST, FL 33540</p> <p>ARCHITECT'S PROJECT No: 1729A</p> <p>OWNER: CITY OF KEY WEST Address: MALLORY SQUARE Tel: 305-809-3963 Representative: City of Key West email: Korn.Winter@cityofkeywest-fl.gov</p> <p>ARCHITECT: BENDER & ASSOCIATES ARCHITECTS, P.A. Address: 410 Angela Street, Key West, FL 33540 Tel: (305) 296-1347 Fax: (305) 296-1721 E-mail: info@benderarchitects.com Project Manager: Bert Bender (Principal-in-Charge) Project Architect: Craig Stuekelberg</p> <p>ENGINEERING CONSULTANTS: STRUCTURAL: ALMATIC ENGINEERING SERVICES, INC. Address: 6501 Arlington Expressway, Bldg. B, Suite 201, Jacksonville, FL 32211 Tel: (904) 743-4633 Representative: Mark J. Keister, P.E.</p> <p>PROJECT NOTE: THE CABLE HUTS ARE HISTORIC STRUCTURES. CONTRACTOR SHALL PERFORM WORK WITH THIS IN MIND, USING ALL APPLICABLE SAFETY AND OSHA STANDARDS AS REQUIRED TO MAINTAIN A SAFE ENVIRONMENT BOTH ON THE ROOF AND ON THE ENTIRE PROPERTY. CONTRACTOR SHALL COORDINATE WITH THE BUILDING OWNER AS REQUIRED FOR DELIVERIES, PARKING AREAS, GROUND STAGING AREAS, ETC.</p>	<p>GENERAL NOTES</p> <ol style="list-style-type: none"> All work shall comply with the Florida Building Code, latest edition, and all applicable laws, codes and ordinances of the City, County, and the State of Florida. In the City of Key West, applicable Codes forming the basis of this design and compliance requirements for the Contractor include: FLORIDA BUILDING CODE - Building 6th Edition - 2017 FLORIDA BUILDING CODE - Landmark 6th Edition - 2017 FLORIDA BUILDING CODE - Residential 6th Edition - 2017 FLORIDA BUILDING CODE - Fuel Gas 6th Edition - 2017 FLORIDA BUILDING CODE - Mechanical 6th Edition - 2017 NATIONAL ELECTRICAL CODE 2014 EDITION NFPA 101 LIFE SAFETY CODE w/ Florida Modifications 2006 FLORIDA FIRE PREVENTION CODE 2007 EDITION NFPA 1 2008 EDITION This project is designed in accordance with A.S.C.E. 7-10 to resist wind loads of 180 mph (3 second gust). Prior to submitting a bid, verify all existing conditions and dimensions on the job site, as part of pre-construction activities. Contours and/or existing grades shown are approximate. Verify with field conditions. Final grading shall provide gradual slopes and grades. Slope all grades away from the building. Planting areas shall be graded with soil suitable for planting. Rock and debris will not be allowed. Where discrepancies between drawings, specifications, and code requirements occur, adhere to the most stringent requirement. Dimensions shall take precedence over scale. All new utilities shall be underground. Drawings and specifications are complementary. Refer to all sheets of drawings and applicable sections of the specifications for interferences of work with related trades. After completion of construction remove all debris and construction equipment. Restore site to original condition. Notify owner of any possible artifacts uncovered during site grading and throughout the course of construction. Furnish a receipt on site to contain construction debris and maintain the site in an orderly manner to ensure public safety and prevent blowing debris. Comply with all requirements for selective demolition as specified, shown on the Demolition Plan, or called for in the selective Demolition Notes. 6101-16003 Use of Saw: The personal seal, signature and date of the architect or interior designer shall appear on all architectural or interior design documents to be filed for public record and shall be construed to obligate his partners or his corporation. A corporate seal alone is insufficient. Documents shall be signed personally and sealed by the responsible architect or interior designer. Final official record documents (not tracings, etc.) shall be so signed. The signing and sealing of the specification book sheets shall be considered complete. All drawing sheets and pages shall be so signed and sealed. An architect or interior designer shall not use his seal or any other seal or an architect or interior designer unless holding at the time a certificate of registration and all required renewals thereof. Specific Authority: 481.225, 481.221 FS. Law Implemented: 481.221, 481.225(1)(a), (b), (c), 481.225(1)(g), (h), (i) FS. History: New 12-23-79, Formerly 21B-16.03, Amended 7-27-89, Formerly 21B-16.003, Amended 11-21-94, 4-18-00. 																																																																																																																																												
<p>ABBREVIATIONS</p> <table border="0"> <tr><td>AB</td><td>ANCHOR BOLT</td><td>MIN</td><td>MINIMUM</td></tr> <tr><td>ABC</td><td>AGGREGATE BASE COURSE</td><td>NTS</td><td>NOT TO SCALE</td></tr> <tr><td>A/C</td><td>AIR CONDITIONING</td><td>OS</td><td>OVERALL</td></tr> <tr><td>BLG</td><td>BLOCKING</td><td>OC</td><td>ON CENTER</td></tr> <tr><td>BUR</td><td>BUILT UP ROOF</td><td>OD</td><td>OUTSIDE DIAMETER</td></tr> <tr><td>CAB</td><td>CABINET</td><td>PF</td><td>POUNDS PER CIRC. FOOT</td></tr> <tr><td>CER</td><td>CERAMIC</td><td>PL</td><td>PROPERTY LINE</td></tr> <tr><td>CL</td><td>CENTER LINE</td><td>PLM</td><td>PLASTIC LAMINATE</td></tr> <tr><td>CLD</td><td>CEILING</td><td>PLF</td><td>POUNDS PER LINEAL FOOT</td></tr> <tr><td>CAJ</td><td>CONCRETE MASONRY UNIT</td><td>PNL</td><td>PANEL</td></tr> <tr><td>COL</td><td>COLUMN</td><td>PT</td><td>COX PRESSURE TREATED</td></tr> <tr><td>CONC</td><td>CONCRETE</td><td>PT</td><td>POINT</td></tr> <tr><td>CONC</td><td>CONCRETE</td><td>PVC</td><td>POLYVINYLCHLORIDE</td></tr> <tr><td>DIAG</td><td>DIAGONAL</td><td>R</td><td>RADIUS (OR) RISER</td></tr> <tr><td>DS</td><td>DOWNSPOUT</td><td>R/A</td><td>RETURN AIR</td></tr> <tr><td>DTR</td><td>DRAWER</td><td>REBAR</td><td>STEEL REIN. BAR</td></tr> <tr><td>EJ</td><td>EXPANSION JOINT</td><td>REFR.</td><td>REFRIGERATOR</td></tr> <tr><td>EL</td><td>ELEVATION</td><td>SS</td><td>STAINLESS STEEL</td></tr> <tr><td>ELEC</td><td>ELECTRIC</td><td>SPEC</td><td>SPECIFICATION</td></tr> <tr><td>EQ</td><td>EQUIP.</td><td>TYP</td><td>TYPICAL</td></tr> <tr><td>ENL</td><td>ENLARGED</td><td>UNO</td><td>UNLESS NOTED OTHERWISE</td></tr> <tr><td>FV</td><td>FIELD VERIFY</td><td>VCT</td><td>VINYL COMPOSITION TILE</td></tr> <tr><td>GALV</td><td>GALVANIZED</td><td>VERT</td><td>VERTICAL</td></tr> <tr><td>GR</td><td>GALVANIZED IRON</td><td>W/O</td><td>WITHOUT</td></tr> <tr><td>HRZ</td><td>HORIZONTAL</td><td>WO</td><td>WOOD</td></tr> <tr><td>HW</td><td>HARDWARE</td><td>WRF</td><td>WELDED WIRE FABRIC</td></tr> <tr><td>HVA</td><td>HEATING VENTILATING & AIR CONDITIONING</td><td>WH</td><td>WATER HEATER</td></tr> <tr><td>FOC</td><td>FACE OF CONCRETE</td><td>W/O</td><td>WITHOUT</td></tr> <tr><td>FCS</td><td>FACE OF STUD</td><td></td><td></td></tr> <tr><td>FIN</td><td>FINISH</td><td></td><td></td></tr> <tr><td>FE</td><td>FIRE EXTINGUISHER</td><td></td><td></td></tr> <tr><td>FIN</td><td>FOUNDATION</td><td></td><td></td></tr> <tr><td>FTG</td><td>FOOTING</td><td></td><td></td></tr> <tr><td>ID</td><td>INSIDE DIAMETER</td><td></td><td></td></tr> <tr><td>MAX</td><td>MAXIMUM</td><td></td><td></td></tr> </table>	AB	ANCHOR BOLT	MIN	MINIMUM	ABC	AGGREGATE BASE COURSE	NTS	NOT TO SCALE	A/C	AIR CONDITIONING	OS	OVERALL	BLG	BLOCKING	OC	ON CENTER	BUR	BUILT UP ROOF	OD	OUTSIDE DIAMETER	CAB	CABINET	PF	POUNDS PER CIRC. FOOT	CER	CERAMIC	PL	PROPERTY LINE	CL	CENTER LINE	PLM	PLASTIC LAMINATE	CLD	CEILING	PLF	POUNDS PER LINEAL FOOT	CAJ	CONCRETE MASONRY UNIT	PNL	PANEL	COL	COLUMN	PT	COX PRESSURE TREATED	CONC	CONCRETE	PT	POINT	CONC	CONCRETE	PVC	POLYVINYLCHLORIDE	DIAG	DIAGONAL	R	RADIUS (OR) RISER	DS	DOWNSPOUT	R/A	RETURN AIR	DTR	DRAWER	REBAR	STEEL REIN. BAR	EJ	EXPANSION JOINT	REFR.	REFRIGERATOR	EL	ELEVATION	SS	STAINLESS STEEL	ELEC	ELECTRIC	SPEC	SPECIFICATION	EQ	EQUIP.	TYP	TYPICAL	ENL	ENLARGED	UNO	UNLESS NOTED OTHERWISE	FV	FIELD VERIFY	VCT	VINYL COMPOSITION TILE	GALV	GALVANIZED	VERT	VERTICAL	GR	GALVANIZED IRON	W/O	WITHOUT	HRZ	HORIZONTAL	WO	WOOD	HW	HARDWARE	WRF	WELDED WIRE FABRIC	HVA	HEATING VENTILATING & AIR CONDITIONING	WH	WATER HEATER	FOC	FACE OF CONCRETE	W/O	WITHOUT	FCS	FACE OF STUD			FIN	FINISH			FE	FIRE EXTINGUISHER			FIN	FOUNDATION			FTG	FOOTING			ID	INSIDE DIAMETER			MAX	MAXIMUM			<p>SYMBOLS LEGEND</p> <p>DWG. ON SHEET REFERENCE SHEET</p> <p>CROSS SECTION 1/4"=1'-0" DRAWING SCALE</p> <p>SECTION & DETAIL DRWG. TITLES</p> <p>FLOOR PLANS, ETC. (THROUGHOUT DWGS.)</p> <p>SITE PLANS (ONCE ONLY)</p> <p>NORTH ARROWS</p> <p>BUILDING SECTION</p> <p>WALL SECTION</p> <p>CUT DETAIL INDICATOR</p> <p>BLOWN-UP DETAIL INDICATOR (PERTAINS TO DETAIL PLAN INDICATOR ON SMALLER SCALE PLAN)</p> <p>WALL ELEVATION INDICATOR (SHOWN WITHIN ROOM ON PLAN)</p> <p>ROOM NUMBER INDICATOR (SHOWN BESIDE OR UNDER ROOM NAME)</p> <p>DOOR OPENING INDICATOR (EACH OPENING SCHEDULED SEPARATELY)</p> <p>WINDOW INDICATOR (EACH WINDOW TYPE & SIZE SCHEDULED)</p> <p>PARTITION/WALL TYPE INDICATOR (COMMERCIAL & INSTITUTIONAL PROJECTS)</p>	<p>MATERIAL DESIGNATIONS</p> <p>CONCRETE MASONRY UNITS IN PLAN</p> <p>CONC., STUCCO, PLASTER IN ELEV./POURED CONC. IN PLAN</p> <p>METAL IN ELEVATION</p> <p>METAL IN SECTION</p> <p>FINISH WOOD IN ELEV. & IN SECTION</p> <p>DIMENSION LUMBER IN SECTION (CONTINUOUS)</p> <p>WOOD BLOCKING IN SECTION (DISCONTINUOUS)</p> <p>GYPSUM WALL BOARD IN SECTION (LARGE SCALE)</p> <p>EARTH, NATURAL SUBSTRATE</p> <p>GRAVEL, AGGREGATE BASE COURSE, FILL</p> <p>FIBERGLASS BATT INSULATION</p> <p>RIGID INSULATION</p> <p>PARTITIONS & WALLS</p> <p>CONCRETE MASONRY UNITS</p> <p>POURED CONCRETE</p> <p>WOOD FRAME</p> <p>METAL STUDS</p> <p>EXISTING CONSTRUCTION TO REMAIN</p> <p>EXISTING CONSTRUCTION TO BE DEMOLISHED</p>	<p>SHEET INDEX</p> <p>A0.0 SITE LOCATION MAP, SHEET INDEX, SURVEY, LOT / ZONING INFORMATION, GENERAL NOTES, FLORIDA ADMINISTRATIVE CODE, SYMBOLS LEGEND</p> <p>C1.0 ONE SITE PLAN</p> <p>C1.1 ENLARGED ONE PLAN</p> <p>D1.0 DEMOLITION PLAN</p> <p>D2.0 DEMO SECTION AND ELEVATIONS</p> <p>D3.1 DEMO ELEVATIONS</p> <p>A1.0 PROPOSED FLOOR PLAN</p> <p>A2.0 EXTERIOR ELEVATIONS</p> <p>A2.1 EXTERIOR ELEVATIONS (CONTINUOUS)</p> <p>A3.0 BUILDING SECTION</p> <p>A5.0 ROOF PLAN AND DETAILS</p> <p>A6.0 ENLARGED WALL SECTION/ DETAILS</p> <p>S0.1 GENERAL NOTES</p> <p>S1.1 STRUCTURAL PLANS</p> <p>S2.1 STRUCTURAL SECTIONS</p> <p>S3.1 STRUCTURAL SECTIONS</p> <p>E1.0 ELECTRICAL PLAN, NOTES AND SYMBOLS</p> <p>DESCRIPTION OF WORK:</p> <p>COMPLETE AS-BUILT EXISTING CONDITION DOCUMENTS, DEMOLISH INDICATED AREAS, RESTORE STRUCTURE TO HISTORIC CONDITIONS AS INDICATED, PROVIDE PROTECTION OVERHEAD AND POST CONSTRUCTION DOCUMENTATION.</p>
AB	ANCHOR BOLT	MIN	MINIMUM																																																																																																																																												
ABC	AGGREGATE BASE COURSE	NTS	NOT TO SCALE																																																																																																																																												
A/C	AIR CONDITIONING	OS	OVERALL																																																																																																																																												
BLG	BLOCKING	OC	ON CENTER																																																																																																																																												
BUR	BUILT UP ROOF	OD	OUTSIDE DIAMETER																																																																																																																																												
CAB	CABINET	PF	POUNDS PER CIRC. FOOT																																																																																																																																												
CER	CERAMIC	PL	PROPERTY LINE																																																																																																																																												
CL	CENTER LINE	PLM	PLASTIC LAMINATE																																																																																																																																												
CLD	CEILING	PLF	POUNDS PER LINEAL FOOT																																																																																																																																												
CAJ	CONCRETE MASONRY UNIT	PNL	PANEL																																																																																																																																												
COL	COLUMN	PT	COX PRESSURE TREATED																																																																																																																																												
CONC	CONCRETE	PT	POINT																																																																																																																																												
CONC	CONCRETE	PVC	POLYVINYLCHLORIDE																																																																																																																																												
DIAG	DIAGONAL	R	RADIUS (OR) RISER																																																																																																																																												
DS	DOWNSPOUT	R/A	RETURN AIR																																																																																																																																												
DTR	DRAWER	REBAR	STEEL REIN. BAR																																																																																																																																												
EJ	EXPANSION JOINT	REFR.	REFRIGERATOR																																																																																																																																												
EL	ELEVATION	SS	STAINLESS STEEL																																																																																																																																												
ELEC	ELECTRIC	SPEC	SPECIFICATION																																																																																																																																												
EQ	EQUIP.	TYP	TYPICAL																																																																																																																																												
ENL	ENLARGED	UNO	UNLESS NOTED OTHERWISE																																																																																																																																												
FV	FIELD VERIFY	VCT	VINYL COMPOSITION TILE																																																																																																																																												
GALV	GALVANIZED	VERT	VERTICAL																																																																																																																																												
GR	GALVANIZED IRON	W/O	WITHOUT																																																																																																																																												
HRZ	HORIZONTAL	WO	WOOD																																																																																																																																												
HW	HARDWARE	WRF	WELDED WIRE FABRIC																																																																																																																																												
HVA	HEATING VENTILATING & AIR CONDITIONING	WH	WATER HEATER																																																																																																																																												
FOC	FACE OF CONCRETE	W/O	WITHOUT																																																																																																																																												
FCS	FACE OF STUD																																																																																																																																														
FIN	FINISH																																																																																																																																														
FE	FIRE EXTINGUISHER																																																																																																																																														
FIN	FOUNDATION																																																																																																																																														
FTG	FOOTING																																																																																																																																														
ID	INSIDE DIAMETER																																																																																																																																														
MAX	MAXIMUM																																																																																																																																														

REVISIONS

HISTORIC CABLE HUTS
WALL STREET, MALLORY SQUARE
KEY WEST, FLORIDA, 33040



410 Angela Street
Key West, Florida 33540
Telephone (305) 296-1347
Fuehville (305) 296-1721
Florida License AL000022

Bender & Associates
ARCHITECTS

Project # 1729A

SITE MAP
PROJECT DIRECTORY
GENERAL NOTES
ABBREVIATIONS
SHEET INDEX
SYMBOL LEGEND

Date: 09/28/2020

A0.0

1 OF 17

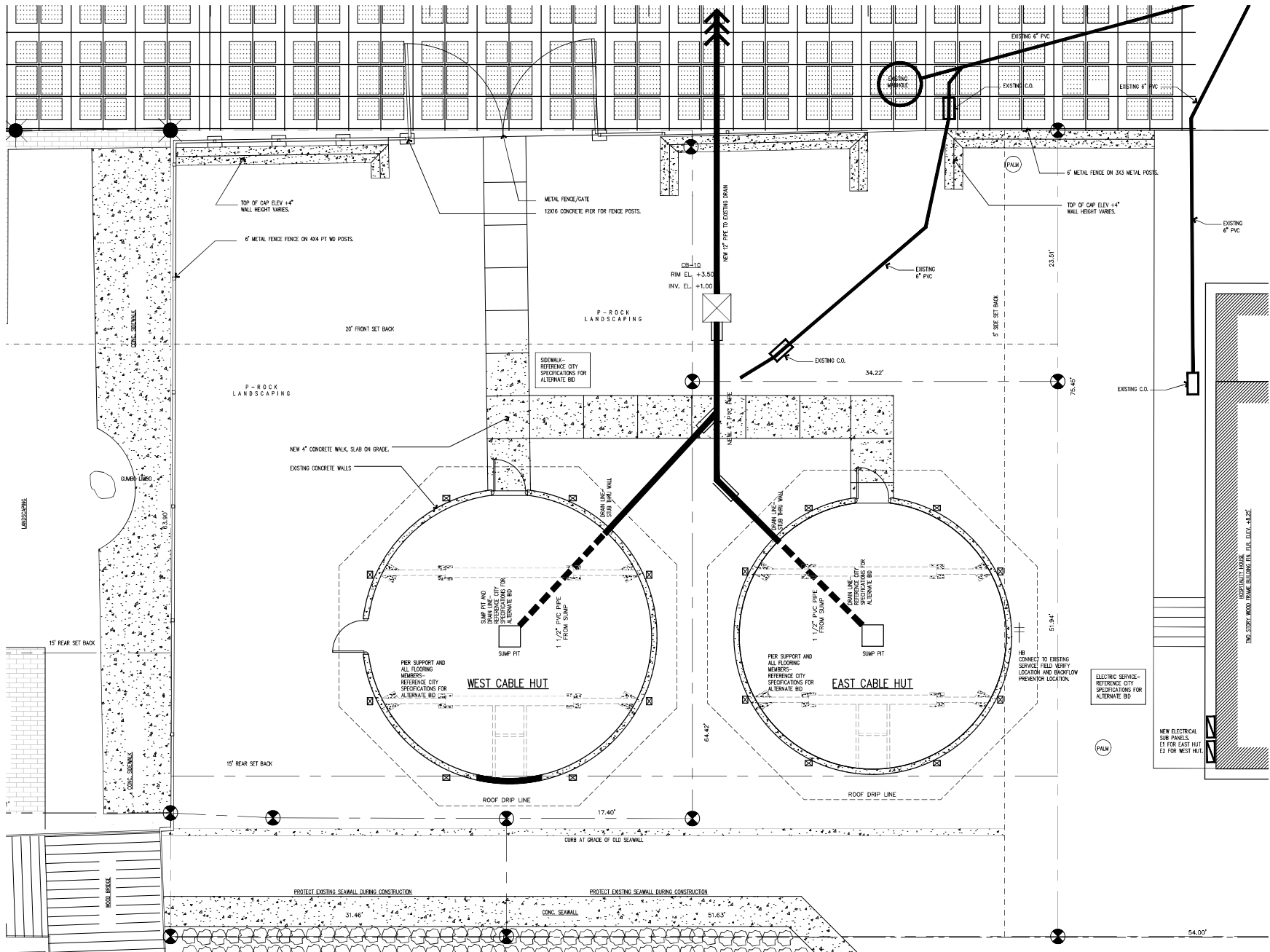

**HISTORIC MALLORY
 SQUARE CABLE HUTS**
 KEY WEST, FLORIDA



410 Angela Street
 Key West, Florida 33840
 Telephone (305) 386-1242
 Facsimile (305) 298-2722
 Florida License ALC062822

Bender & Associates
ARCHITECTS
 P.A.

Project N : 1728A
 SITE UTILITY PLAN
 Date: 09/28/2020

C1.1
 3 OF 17

1 UTILITY PLAN
 C1.1 SCALE: 1/4" = 1'



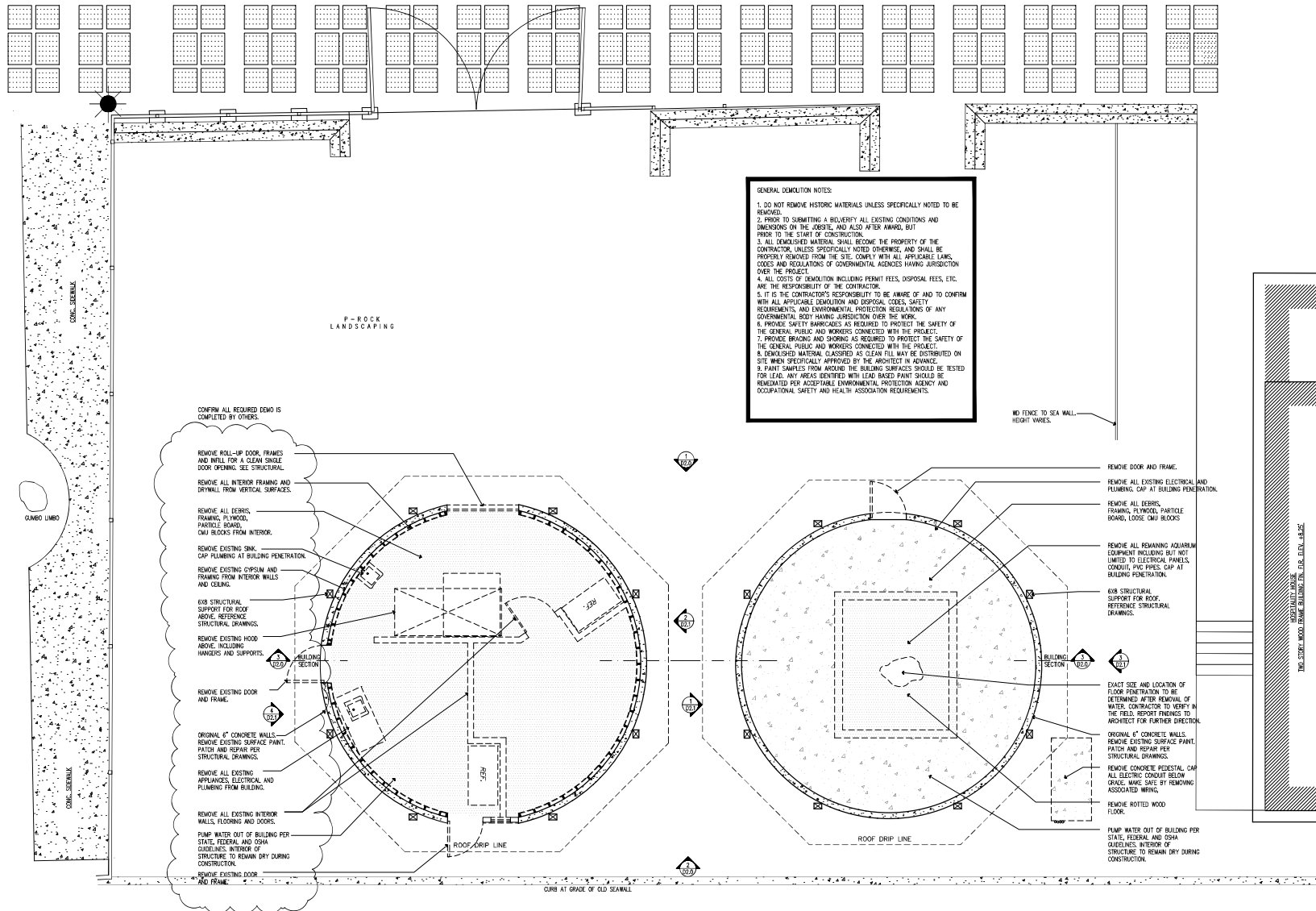

GENERAL DEMOLITION NOTES:

- DO NOT REMOVE HISTORIC MATERIALS UNLESS SPECIFICALLY NOTED TO BE REMOVED.
- PRIOR TO SUBMITTING A BID/VEHY ALL EXISTING CONDITIONS AND DIMENSIONS ON THE JOBITE, AND ALSO AFTER AWARD, BUT PRIOR TO THE START OF CONSTRUCTION.
- ALL DEMOLISHED MATERIAL SHALL BECOME THE PROPERTY OF THE CONTRACTOR, UNLESS SPECIFICALLY NOTED OTHERWISE, AND SHALL BE PROPERLY REMOVED FROM THE SITE COMPLY WITH ALL APPLICABLE LAWS, CODES AND REGULATIONS OF GOVERNMENTAL AGENCIES HAVING JURISDICTION OVER THE PROJECT.
- ALL COSTS OF DEMOLITION INCLUDING PERMIT FEES, DISPOSAL FEES, ETC. ARE THE RESPONSIBILITY OF THE CONTRACTOR.
- IT IS THE CONTRACTOR'S RESPONSIBILITY TO BE AWARE OF AND TO CONFORM WITH ALL APPLICABLE DEMOLITION AND DISPOSAL, CODES, SAFETY REQUIREMENTS, AND ENVIRONMENTAL PROTECTION REGULATIONS OF ANY GOVERNMENTAL BODY HAVING JURISDICTION OVER THE WORK.
- PROVIDE SAFETY BARRICADES AS REQUIRED TO PROTECT THE SAFETY OF THE GENERAL PUBLIC AND WORKERS CONNECTED WITH THE PROJECT.
- PROVIDE BRACING AND SHORING AS REQUIRED TO PROTECT THE SAFETY OF THE GENERAL PUBLIC AND WORKERS CONNECTED WITH THE PROJECT.
- DEMOLISHED MATERIAL CLASSIFIED AS CLEAN FILL MAY BE DISTRIBUTED ON SITE WHEN SPECIFICALLY APPROVED BY THE ARCHITECT IN ADVANCE.
- PAINT SAMPLES FROM AROUND THE BUILDING SURFACES SHOULD BE TESTED FOR LEAD. ANY AREAS IDENTIFIED WITH LEAD BASED PAINT SHOULD BE REMEDIATED PER ACCEPTABLE ENVIRONMENTAL PROTECTION AGENCY AND OCCUPATIONAL SAFETY AND HEALTH ASSOCIATION REQUIREMENTS.

2 WEST CABLE HUT DEMO PLAN
SCALE: 1/4" = 1'

1 EAST CABLE HUT DEMO PLAN
SCALE: 1/4" = 1'

HISTORIC MALLORY
SQUARE CABLE HUTS
KEY WEST, FLORIDA



410 Angela Street
Key West, Florida 33540
Telephone: (305) 336-1347
Facsimile: (305) 336-2727
Florida License AL1902022

Bender & Associates
ARCHITECTS
P.A.C.

Project No. 1728A
DEMOLITION PLANS

Date: 09/28/2020

D1.0

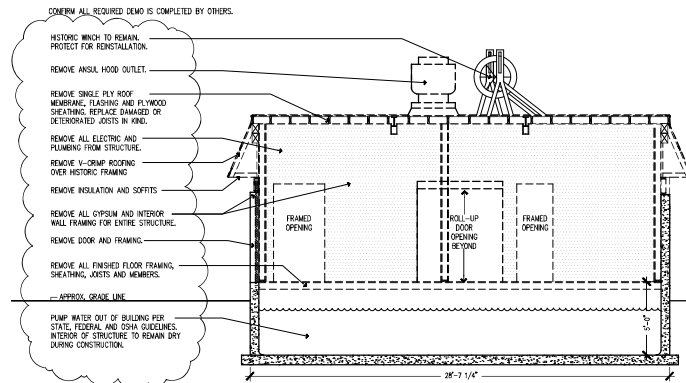

3 TRANSVERSE DEMO SECTION
SCALE: 1/4" = 1'

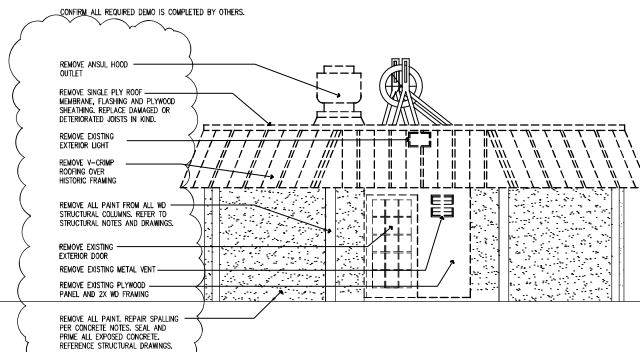
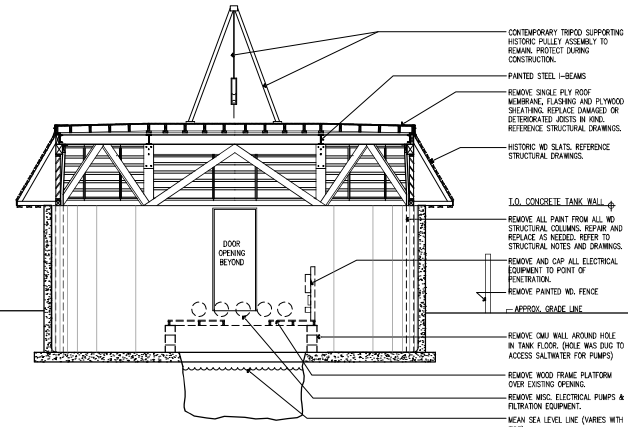

2 SOUTH ELEVATION: DEMO
SCALE: 1/4" = 1'

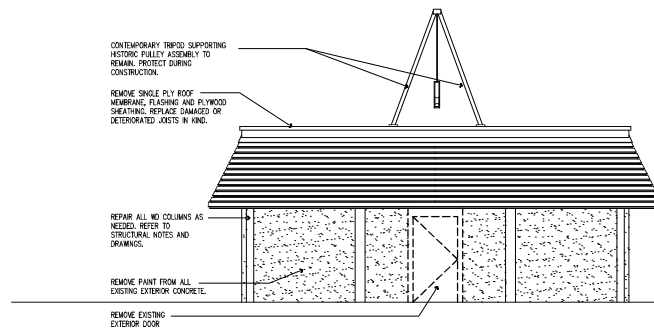
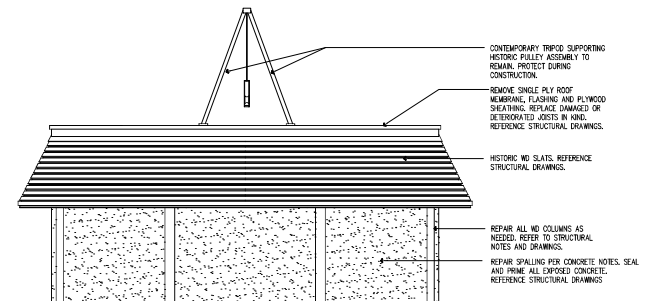

1 NORTH ELEVATIONS: DEMO
SCALE: 1/4" = 1'

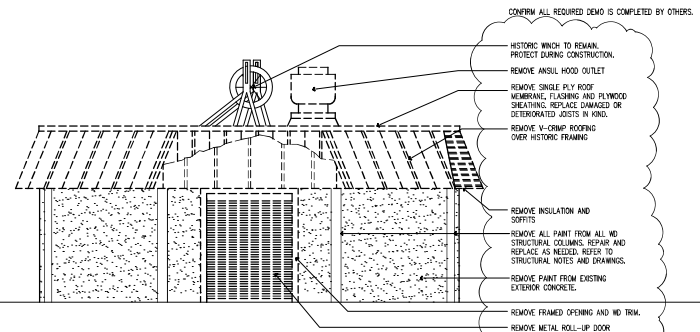

HISTORIC MALLORY
SQUARE CABLE HUTS
KEY WEST, FLORIDA



410 Angela Street
Key West, Florida 33840
Telephone (305) 386-1947
Facsimile (305) 398-2727
Florida License AL0002022

Bender & Associates
ARCHITECTS
P.A.

Project # 9 1729A
EXHIBITION
ELEVATIONS AND
SECTION
Date: 09/28/2020

D2.0

HISTORIC MALLORY
 SQUARE CABLE HUTS
 KEY WEST, FLORIDA



410 Angela Street
 Key West, Florida 33040
 Telephone: (305) 586-1547
 Facsimile: (305) 596-2727
 Florida License AL0002022

Bender & Associates
 ARCHITECTS
 P.A.

Project # 17294
 EXHIBITION
 ELEVATIONS

Date: 09/28/2020

D2.1

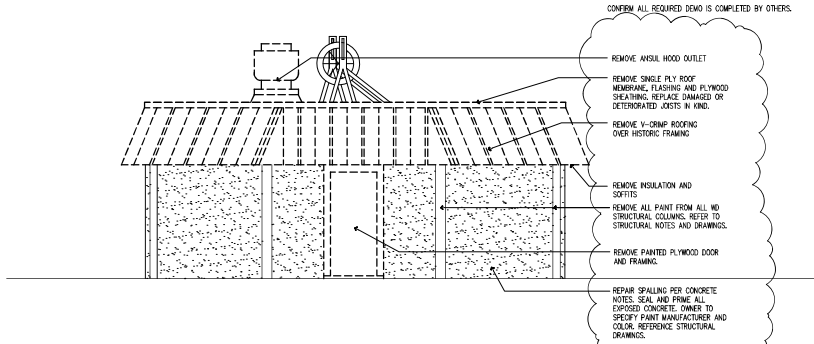

4 WEST CABLE HUT - WEST DEMO ELEVATION
 D2.1 SCALE: 1/4" = 1'

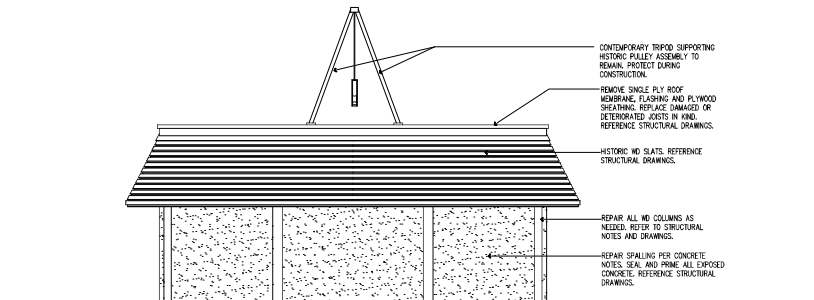

3 EAST CABLE HUT - EAST DEMO ELEVATION
 D2.1 SCALE: 1/4" = 1'

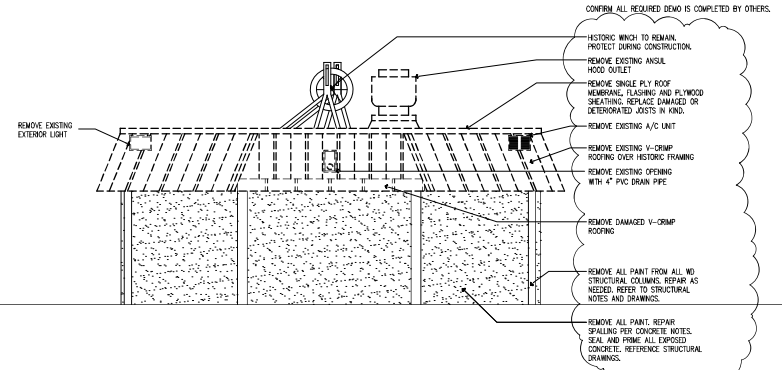

2 WEST CABLE HUT - WEST DEMO ELEVATION
 D2.1 SCALE: 1/4" = 1'

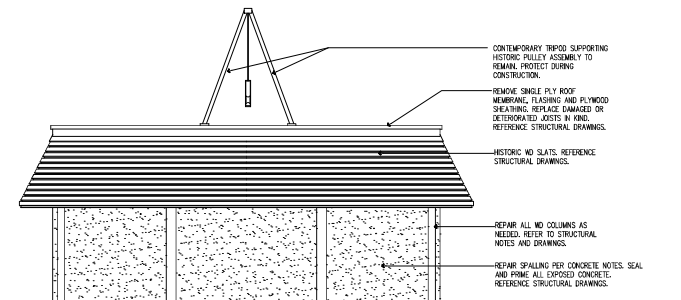

1 EAST CABLE HUT - WEST DEMO ELEVATION
 D2.1 SCALE: 1/4" = 1'

COLUMN NOTES

EAST CABLE HUT:

A	TYPE 1	CONC PIER
B	TYPE 1	CONC PIER
C	TYPE 1	CONC PIER
D	TYPE 1	CONC PIER
E	TYPE 1	CONC PIER
F	TYPE 1	CONC PIER
G	TYPE 1	CONC PIER
H	TYPE 1	CONC PIER

WEST CABLE HUT:

M	TYPE 1	CONC PIER
N	TYPE 1	CONC PIER
O	TYPE 1	CONC PIER
P	TYPE 1	CONC PIER
Q	TYPE 1	CONC PIER
R	TYPE 1	CONC PIER
S	TYPE 1	CONC PIER
T	TYPE 1	CONC PIER

REFER TO STRUCTURAL DRAWINGS FOR CONNECTION SPECIFICATIONS.

- GENERAL FRAMING NOTES**
- COMPLY WITH "GENERAL STRUCTURAL NOTES" INCLUDED ELSEWHERE IN THESE DOCUMENTS.
 - WHERE WOOD JOISTS/BEAMS ETC. FRAME INTO OTHER MEMBERS, AND LEDGERS ARE NOT PROVIDED, INSTALL SIMPSON "M" SERIES JOIST HANGERS. WHEN INSTALLING W/DO PRESSURE TREATED LUMBER, CONTRACTOR HAS THE OPTION OF PROVIDING OTHER STAINLESS STEEL JOIST HANGERS AND STAINLESS STEEL FASTENERS, OR SIMPSON DMK (285) GALVANIZED JOIST HANGERS WITH HOT DIP GALVANIZED FASTENERS. CONTRACTOR SHALL NOT MIX STAINLESS STEEL WITH HOT DIP GALVANIZED.
 - PROVIDE HOT DIP (ZMAK) GALVANIZED HURRICANE CLIPS AT ALL RAFTERS AT BEARING LOCATIONS.
 - PROVIDE SOLID BLOCKING AT MIDSPAN OF ALL JOISTS AND RAFTERS FOR SPANS OF 8' AND OVER. USE 3 ROWS OF BLOCKING WHERE SPANS EXCEED 16 FEET.
 - INSTALL ALL PLYWOOD SHEATHING TO LAP JOINTS AT ROOF. USE 3/4" MINIMUM THICKNESS P.T. PLYWOOD NAILED WITH 8d GALVANIZED NAILS, 4" O.C. ALONG PLATES, 4" O.C. ALONG SILL BEAMS TOP AND BOTTOM, AND 4" O.C. IN THE FIELD, UNLESS NOTED ON STRUCTURAL.
 - ALL FRAMING LUMBER AND PLYWOOD SHALL BE PRESSURE TREATED.
 - ALL PRESSURE TREATED WOOD USED ON RESIDENTIAL PROJECTS MUST BE FREE OF ARSINIC AND CHROMIUM AFTER AQUEOUS USE. AOC OR OTHER EPA APPROVED TREATED LUMBER ON RESIDENTIAL PROJECTS. ON COMMERCIAL PROJECTS, COT TREATED LUMBER IS ACCEPTABLE IN CONCEALED SPACES.
 - ADD ARSINIC FREE LUMBER HAS BEEN FOUND TO CORRODE STANDARD ELECTROPLATED GALVANIZED NAILS AND SCREWS. ANY METAL FASTENERS (FRAMING OR FINISH) USED ON AOC PRESSURE TREATED LUMBER SHALL BE STAINLESS STEEL, GRADE 304 OR GREATER, OR HOT DIP GALVANIZED, CONFORMING TO ASTM A-153/ASTM STANDARD A653 (CLASS G-185). STAINLESS STEEL AND HOT DIP GALVANIZED METALS SHALL NOT COME IN CONTACT WITH EACH OTHER.
 - ALL STRUCTURAL LUMBER, I.E. JOISTS, GIRDERS, BEAMS, RAFTERS, ETC., SHALL BE SOUTHERN YELLOW PINE NO. 1 DENSE, WITH MINIMUM 6 OF 1300 PSI, BEFORE PRESSURE TREATMENT. (PRESSURE TREATMENT REDUCES FIBER STRESS BY 15% TO 1100 P.S.I.)

- PROJECT SCOPE:**
- DEMO PROJECT AS INDICATED ON DRAWINGS. REMOVE DEBRIS FROM INTERIOR, DE-WATER, REMOVE EXISTING TIN ROOFING, REMOVE PAINT FROM EXTERIOR OF BUILDING AND WOODEN COLUMNS, REMOVE DOORS AS INDICATED, REMOVE ALL MECHANICAL, ELECTRICAL AND PLUMBING SYSTEMS. COMPLY WITH GENERAL DEMOLITION NOTES. (WEST CABLE HUT DEMO COMPLETED BY OTHERS.)
 - STRUCTURAL STEEL: REMOVE CORROSION, PRIME WITH CORROSION PREVENTIVE COATING, PAINT WITH COLOR PER ARCHITECTS REQUEST. REPLACE ANY CORRODED STRIPS OR BANDING ON OTHER METAL COMPONENTS AS NEEDED.
 - CONCRETE: TEST EXISTING CONCRETE FOR MIXTURE COMPOSITION, REPAIR SPALLS AND CRACKS WITH BEST PRACTICES AND PER ENGINEERS DRAWINGS AND RECOMMENDATIONS. REPAIR INTERIOR AS NEEDED. NOTIFY ARCHITECT OF ANY STRUCTURAL OR UNDESIRABLE CONDITIONS. COMPLY WITH GENERAL STRUCTURAL NOTES AND FOUNDATION AND CONCRETE NOTES.
 - WOOD FRAMING: REPLACE ANY DAMAGED OR DECAYED MEMBERS. NOTIFY ARCHITECT OF ANY STRUCTURAL ISSUES. SHEATH OVER EXISTING SHEATHING WITH NEW P.T. SHEATHING, SECURE WITH S.S. SCREWS PER BEST PRACTICES. COMPLY WITH GENERAL FRAMING NOTES. REPAIR AND REPLACE EXTERIOR CEILING AS NEEDED. SEAL WOOD, ON INTERIOR, BUILD 2X6 BECKING, CAPEF 7" LEVEL WITH GRADE AT ENTRY DOOR. REFER TO ARCHITECTURAL DETAILS FOR FRAMING AND LAYOUT. INSURE ALL EXISTING HISTORIC HORIZONTAL SLAT FRAMING IS SECURE, FLUSH AND SQUARE. REFLECTOR PER BEST PRACTICE WITH S.S. SCREWS.
 - ROOFING: INSTALL NEW TPO ROOFING SYSTEM ON EACH CABLE HUT, SPECIFICATIONS AND OUT SHEET TO BE APPROVED BY ARCHITECT. DETAIL PER SHEET AS. CENTER OF THE ROOF IS THE HIGH POINT, SLOPE TO EAVES. PROVIDE RAIN DWP EDGE AS NOTED ON SHEET AS. ROOF HAS EXISTING HISTORIC EQUIPMENT THAT SHOULD BE BASED ONTO NEW CURB PLATFORM.
 - WATER: PROVIDE WATER SERVICE TO BOTH STRUCTURES AS INDICATED ON ARCHITECTURAL PLANS. THESE INCLUDE NEW METER, BACKFLOW PREVENTOR, HOSE BIBS, CUT SHEETS TO BE APPROVED BY ARCHITECT.
 - ENERGY AND DTL: PROVIDE NEW ELECTRICAL SERVICE WITH EXCESS CAPACITY AND LIGHTING, DOORS AND OTHER FINISHES AND LANDSCAPING AS INDICATED ON ARCHITECTURAL DRAWINGS.
 - REFERENCE CITY SPECIFICATIONS FOR ALTERNATE BID ITEMS: SUMP P/T - SUMP DRAIN LINE- ELECTRIC SERVICE - STRUCTURAL FLOOR DECKING AND SUPPORTS.

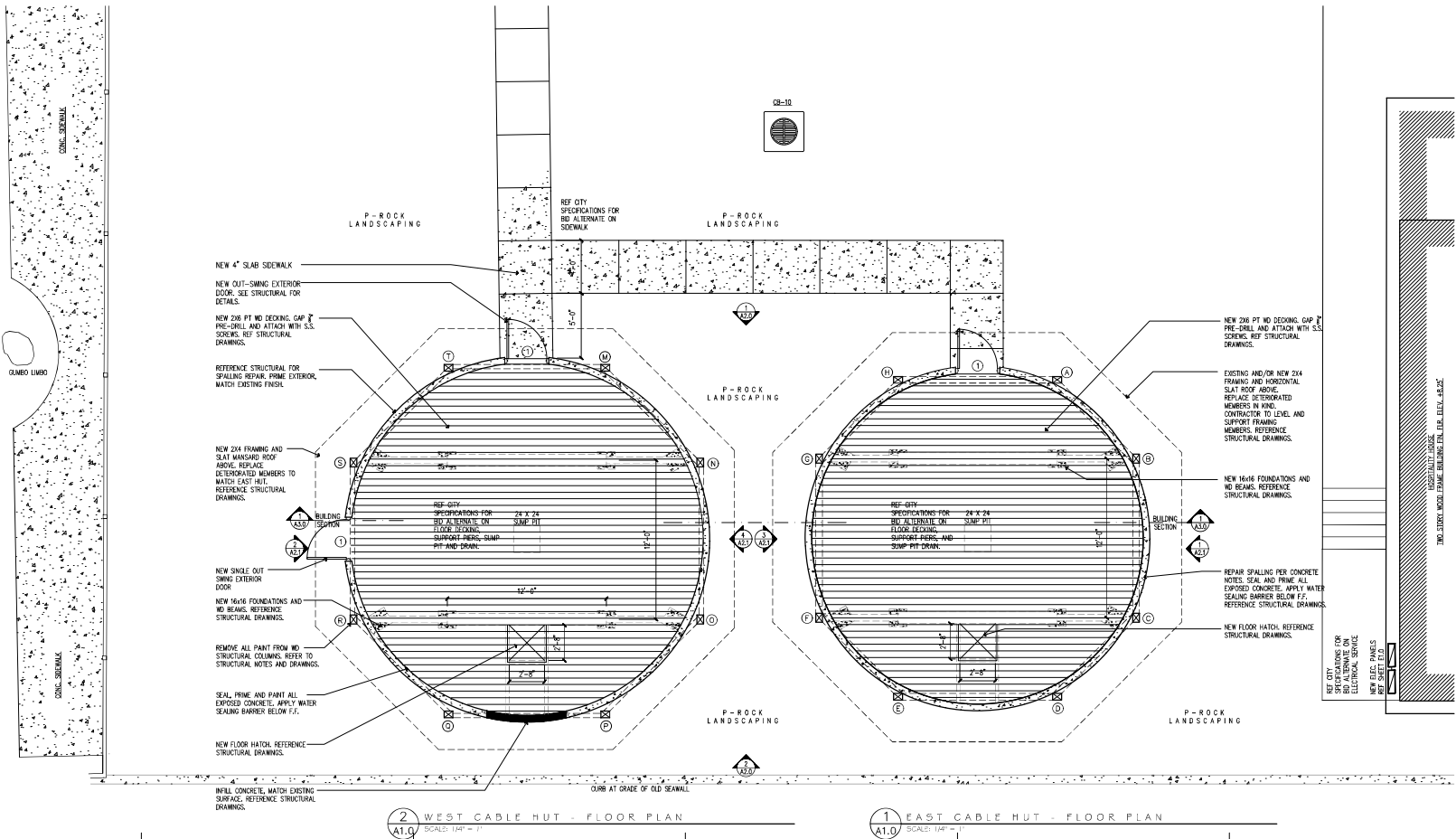

HISTORIC MALLORY SQUARE CABLE HUTS
KEY WEST, FLORIDA



410 Angela Street
Key West, Florida 33540
Telephone: (305) 298-1347
Facsimile: (305) 298-2727
Florida License AIC002022

Bender & Associates
ARCHITECTS
p.c.

Project No. 1729A
PROPOSED PLANS
Date: 09/28/2020

A1.0
7 OF 17

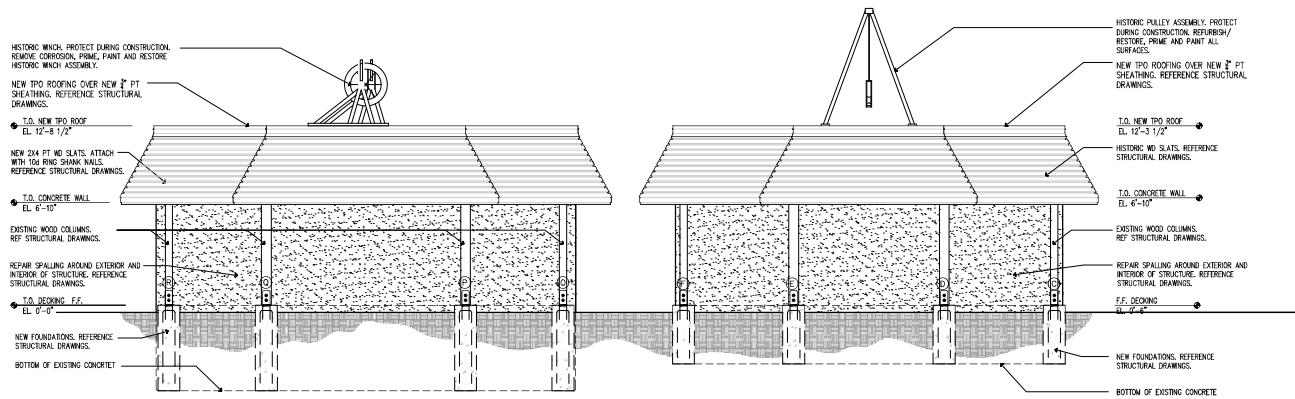

2 PROPOSED SOUTH ELEVATION
A2.0 SCALE: 1/8" = 1'

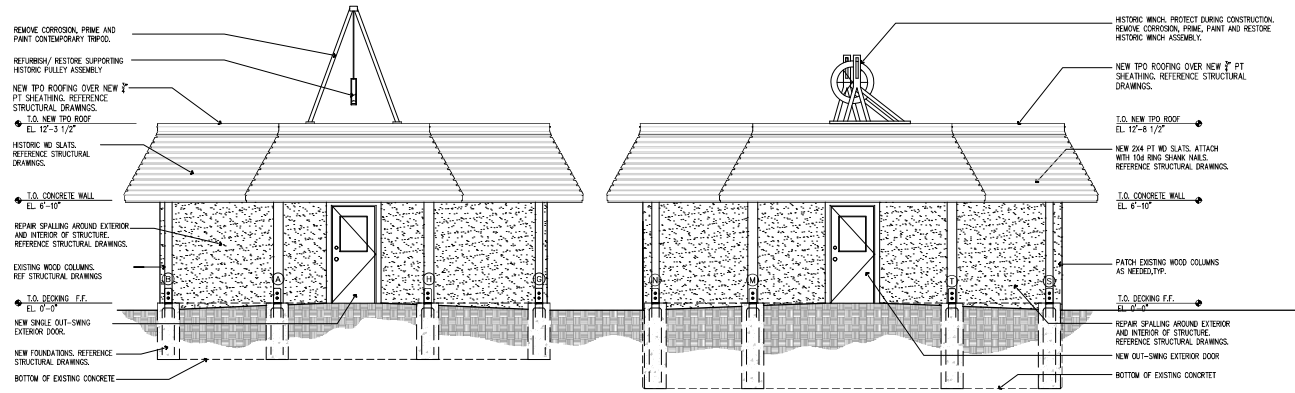

1 PROPOSED NORTH ELEVATION
A2.0 SCALE: 1/8" = 1'

HISTORIC MALLORY
SQUARE CABLE HUTS
KEY WEST, FLORIDA



410 Angela Street
Key West, Florida 33040
Telephone (305) 586-1547
Facsimile (305) 586-2727
Florida License AIC0002022

Bender & Associates
ARCHITECTS
P.A.

Project # 1729A
PROPOSED ELEVATIONS
Date: 09/28/2020

A2.0
8 OF 17

HISTORIC MALLORY
 SQUARE CABLE HUTS
 KEY WEST, FLORIDA



410 Angela Street
 Key West, Florida 33840
 Telephone (305) 588-1847
 Facsimile (305) 588-2727
 Florida License AIC0002022

Bender & Associates
 ARCHITECTS
 P.A.

Project # 1729A
 PROPOSED ELEVATIONS

Date: 09/28/2020

A2.1

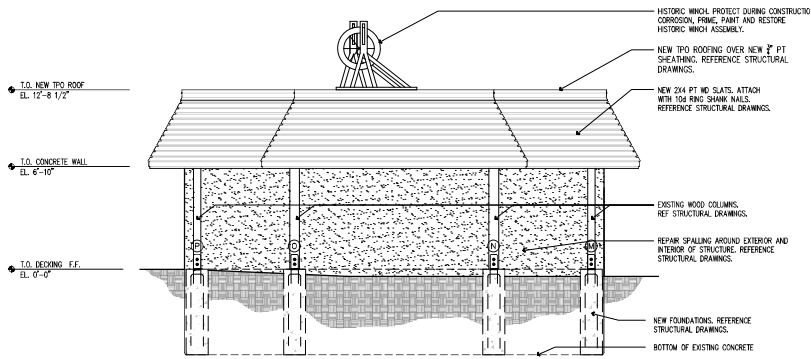

4 WEST CABLE HUT - EAST ELEVATION
 SCALE: 1/4" = 1'

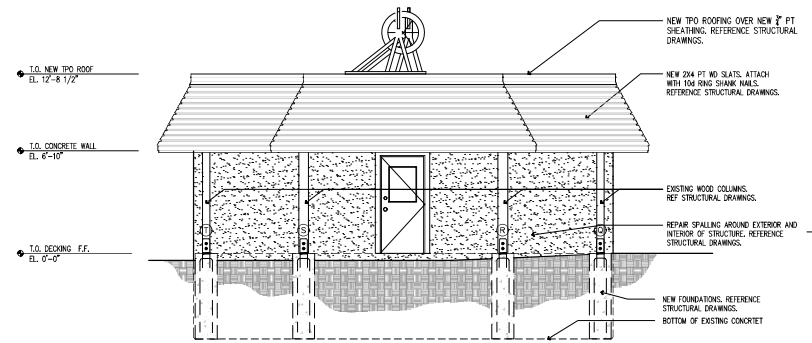

2 WEST CABLE HUT - WEST ELEVATION
 SCALE: 1/4" = 1'

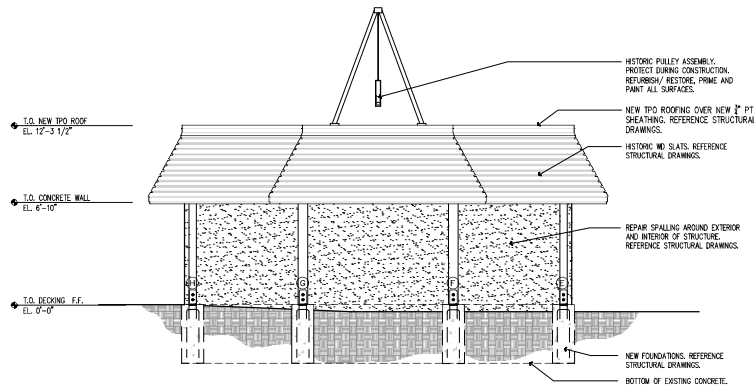

3 EAST CABLE HUT - WEST ELEVATION
 SCALE: 1/4" = 1'

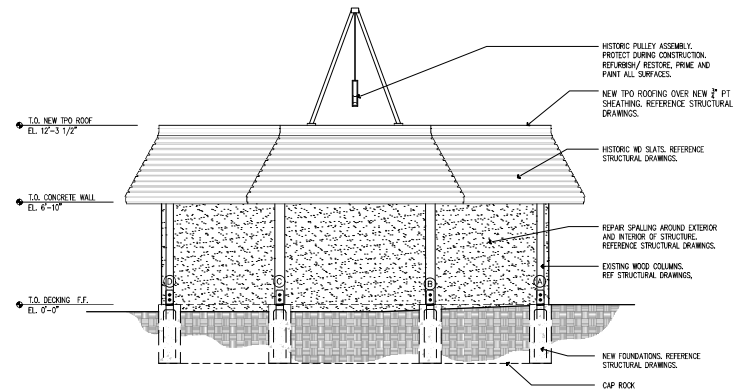

1 EAST CABLE HUT - EAST ELEVATION
 SCALE: 1/4" = 1'

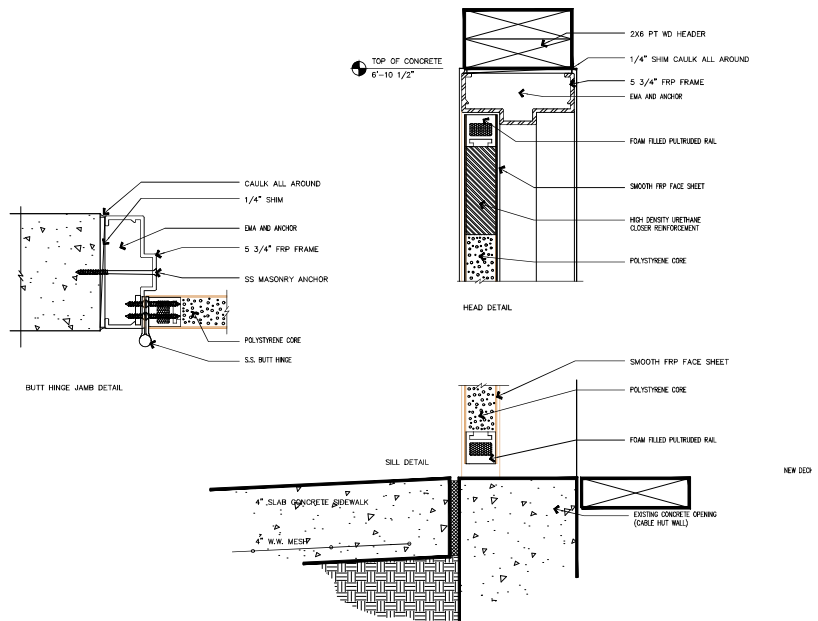

2 DOOR DETAILS
SCALE: 1/4" = 1'-0"

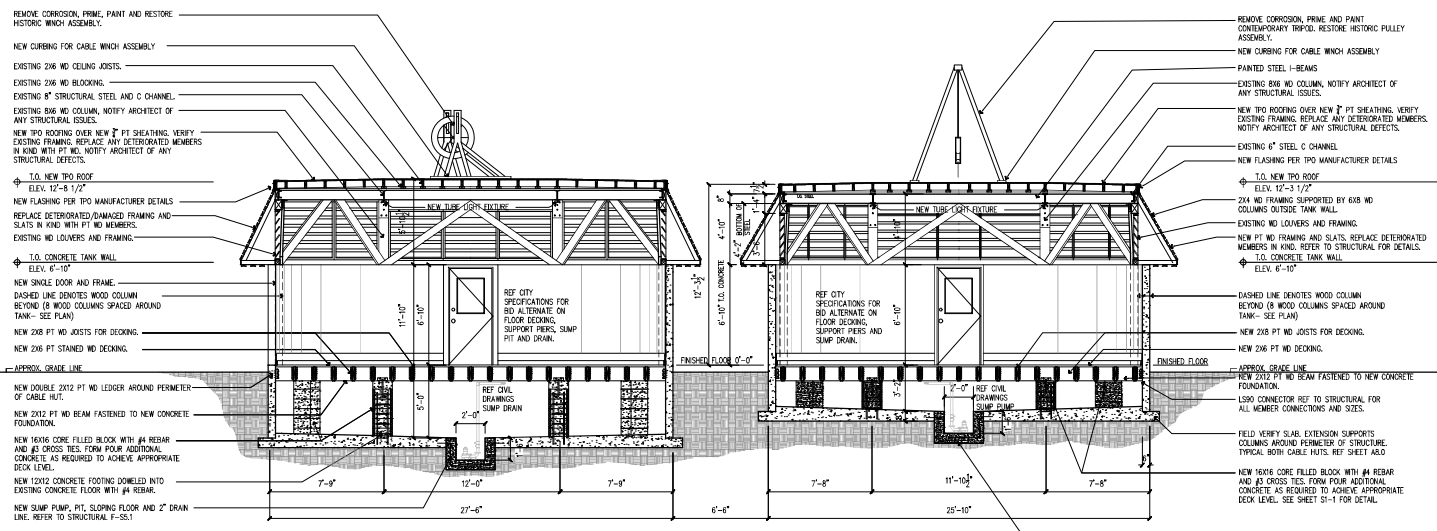

1 TRANSVERSE SECTION
SCALE: 1/4" = 1'-0"

HISTORIC MALLORY
SQUARE CABLE HUTS
KEY WEST, FLORIDA



410 Angela Street
Key West, Florida 33940
Telephone (305) 286-1847
Facsimile (305) 286-2727
Florida License AL0002022

Bender & Associates
ARCHITECTS
P.A.

Project # 1729A
PROPOSED SECTION
Date: 09/28/2020

A3.0

- NOTE:**
- 1) REFER TO MANUFACTURER FOR MOST CURRENT INFORMATION.
 - 2) WOOD NAHLER MUST BE INSTALLED TO MEET CURRENT CODE OR 200 LB PER LINEAR FOOT MINIMUM IN ANY GIVEN DIRECTION.
 - 3) FLANGE OF NAHLER MUST BE FULLY SUPPORTED BY WOOD AND TERMINATED AT LEAST 2" FROM EDGE OF WOOD.
 - 4) ACCEPTABLE BONDING ADHESIVE REQUIRED BETWEEN MEMBRANE AND INSULATION FOR ADHERED SYSTEMS. BONDING ADHESIVE REQUIRED BETWEEN METAL DAM AND MEMBRANE FOR ALL SYSTEMS.

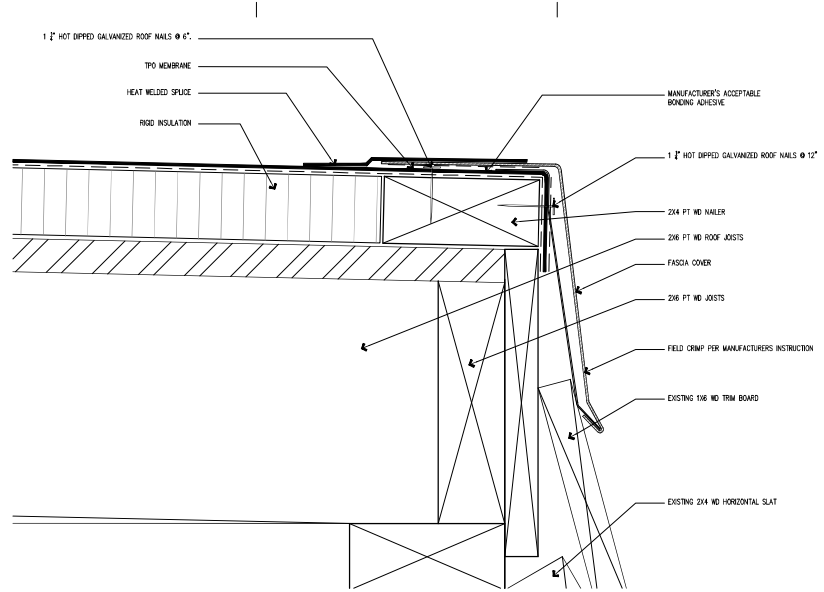

2 TPO ROOF EDGE DETAIL
SCALE: N.T.S.

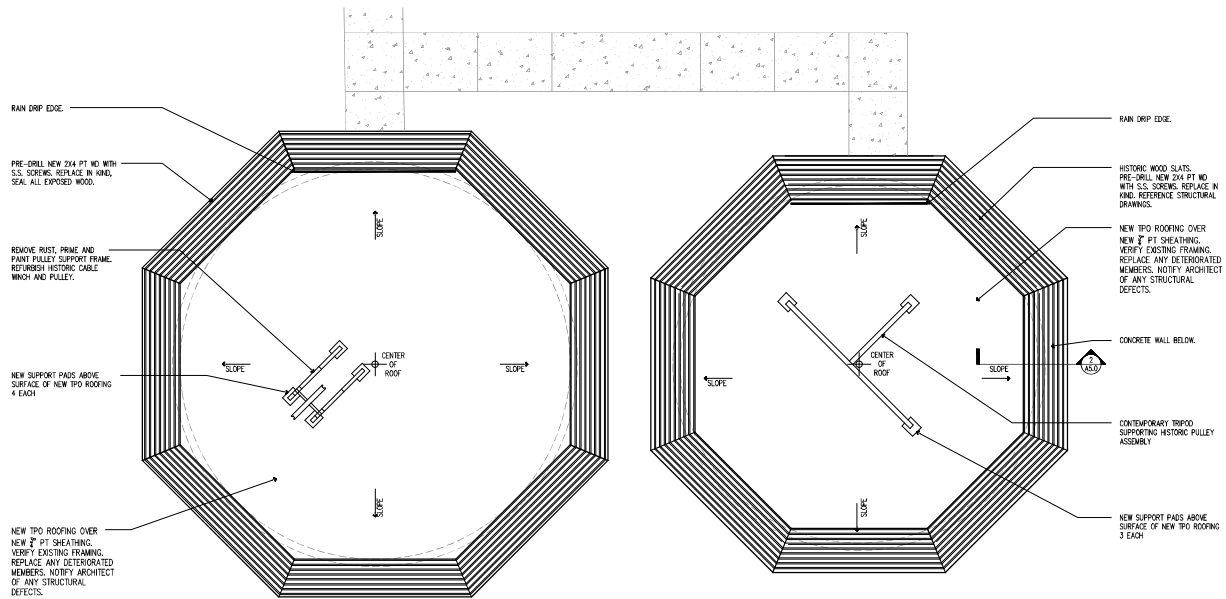

1 CABLE HUT PROPOSED ROOF PLAN
SCALE: 1/4" = 1'

**HISTORIC MALLORY
SQUARE CABLE HUTS**
KEY WEST, FLORIDA



410 Angela Street
Key West, Florida 33540
Telephone: (305) 298-1347
Facsimile: (305) 298-2727
Florida License AL0002022

Bender & Associates
ARCHITECTS
P.A.C.

Project No. 1729A
ROOF PLAN AND DETAILS
Date: 09/28/2020

A5.0

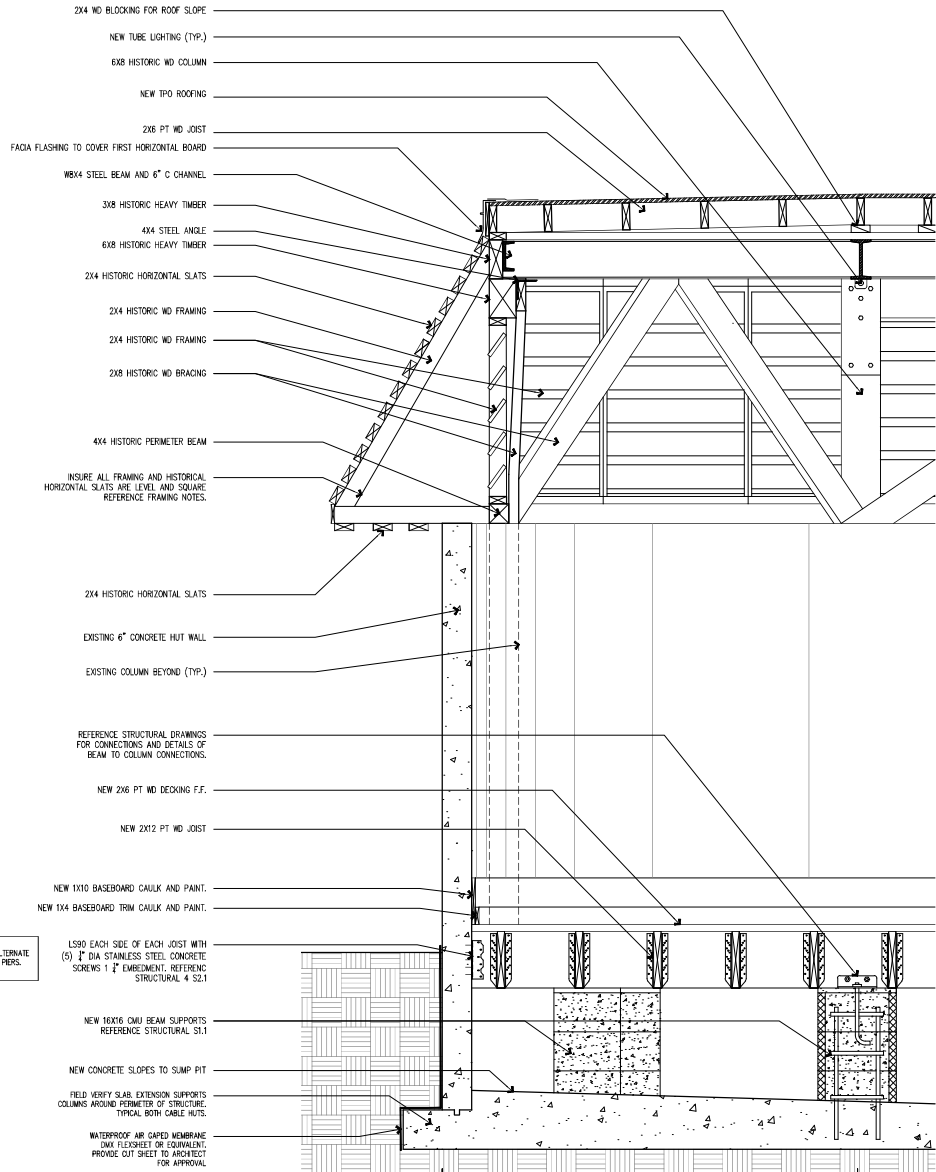

1 ENLARGED SECTION
A8.0 SCALE: 1/2" = 1'

HISTORIC MALLORY
SQUARE CABLE HUTS
KEY WEST, FLORIDA



410 Angela Street
Key West, Florida 33940
Telephone (305) 386-1343
Facsimile (305) 386-2727
Florida License A110002022

Bender & Associates
ARCHITECTS
P.A.

Project # 2729A
ENLARGED WALL SECTION
Date: 09/28/2020

A8.0

GENERAL NOTES

100. DESIGN CRITERIA
- 100.1 DESIGN BUILDING CODE:
- A. FLORIDA BUILDING CODE, SIXTH EDITION (2017)
- 100.2 GRAVITY LOADS:
- A. FLOOR LIVE LOADS:
1. TANK MAT _____ 3,000 PSF
2. FLOOR _____ 100 PSF
- B. ROOF LIVE LOADS:
1. LOW SLOPE ROOF _____ 20 PSF
- 100.3 LATERAL LOADS:
- A. WIND LOADS (IN ACCORDANCE WITH DESIGN BUILDING CODE PER GENERAL NOTE 100.1):
1. ULTIMATE DESIGN WIND SPEED (3 SECOND GUST), V_{ult} = 180 MPH
2. NOMINAL DESIGN WIND SPEED (3 SECOND GUST), V_{asd} = 139 MPH
3. RISK CATEGORY = II
4. EXPOSURE CATEGORY = C
5. ENCLOSURE CLASSIFICATION = ENCLOSED
6. INTERNAL PRESSURE COEFFICIENT (C_{pi}) = +0.18
7. COMPONENTS AND CLADDING PRESSURES: (P_{ult}); ROOF 10 SF: +41 PSF, -167 PSF; 20 SF: +38 PSF, -156 PSF; 50 SF: +33 PSF, -142 PSF; 100 SF: +29 PSF, -131 PSF
110. GENERAL
- 110.1 THESE DRAWINGS HAVE BEEN PRODUCED ENTIRELY ON ATLANTIC ENGINEERING SERVICES CADD SYSTEM. ANY OTHER LETTERING, LINES OR SYMBOLS, OTHER THAN PROFESSIONAL STAMPS AND SIGNATURES, HAVE BEEN MADE WITHOUT THE AUTHORIZATION OF ATLANTIC ENGINEERING SERVICES AND ARE INVALID.
- 110.2 THE STRUCTURAL DRAWINGS SHALL GOVERN THE WORK FOR ALL STRUCTURAL FEATURES. UNLESS NOTED OTHERWISE, THE ARCHITECTURAL DRAWINGS SHALL GOVERN THE WORK FOR ALL DIMENSIONS.
- 110.3 DO NOT SCALE DRAWINGS TO OBTAIN DIMENSIONS. ONLY DIMENSIONS INDICATED ON DRAWINGS MAY BE USED TO ESTABLISH THE LOCATION AND EXTENT OF STRUCTURAL WORK. IF A REQUIRED DIMENSION IS NOT FURNISHED ON DRAWINGS, THE CONTRACTOR SHALL SUBMIT A REQUEST FOR INFORMATION TO OBTAIN THE DIMENSION.
- 110.4 UNLESS OTHERWISE INDICATED, PROVIDE EQUAL SPACING OF STRUCTURAL COMPONENTS BETWEEN OVERALL DIMENSIONS INDICATED ON DRAWINGS.
- 110.5 THE CONTRACTOR SHALL VERIFY ALL EXISTING CONDITIONS, DIMENSIONS, ETC., AND SHALL NOTIFY THE ARCHITECT OF ANY AND ALL DISCREPANCIES, ADDITIONAL INFORMATION, ETC., BEFORE BEGINNING THE WORK.
- 110.6 THE CONTRACTOR SHALL USE EXTREME CAUTION IN THE DEMOLITION OF EXISTING STRUCTURES. SUCH DEMOLITION SHALL BE PERFORMED IN SUCH A MANNER AS TO MAINTAIN THE STRUCTURAL INTEGRITY OF ALL EXISTING STRUCTURES TO REMAIN. PROVIDE SHORING AS REQUIRED.
- 110.7 STRUCTURAL WORK SHALL BE INSPECTED IN ACCORDANCE WITH ALL LOCAL ORDINANCES. THE CONTRACTOR SHALL ENGAGE AN EXPERIENCED, QUALIFIED INSPECTION AGENCY, SUBJECT TO THE REVIEW OF THE ARCHITECT, TO PERFORM ALL INSPECTION WORK, AS REQUIRED.
- 110.8 STRUCTURAL WORK SHALL BE TESTED IN ACCORDANCE WITH THE REQUIREMENTS OF THE GENERAL NOTES. THE CONTRACTOR SHALL ENGAGE AN EXPERIENCED, QUALIFIED TESTING AGENCY, SUBJECT TO THE REVIEW OF THE ARCHITECT, TO PERFORM ALL TESTING WORK, AS REQUIRED.
120. SHOP DRAWINGS AND DELEGATED DESIGN SUBMITTALS
- 120.1 THE CONTRACTOR SHALL SUBMIT SHOP DRAWINGS FOR REVIEW BY ATLANTIC ENGINEERING SERVICES AND THE PROJECT ARCHITECT. SHOP DRAWINGS SHALL BE SUBMITTED FOR ALL STRUCTURAL COMPONENTS INCLUDING, BUT NOT LIMITED TO, THE FOLLOWING:
- A. REINFORCING STEEL FOR CONCRETE AND MASONRY
- B. CONCRETE MIX DESIGN
- C. CONCRETE AND/OR MASONRY POST-INSTALLED ANCHORS
- D. COLD FORMED STEEL FABRICATIONS UTILIZED IN WOOD-TO-WOOD CONNECTIONS.
- 120.2 SHOP DRAWINGS TO BE SUBMITTED SHALL PROVIDE COMPLETE INFORMATION FOR THE PRODUCTS OR COMPONENTS TO BE SUPPLIED. SUBMITTAL INFORMATION SHALL INCLUDE, BUT NOT BE LIMITED TO, MEMBER SIZES AND DIMENSIONS; GRADES OF MATERIAL FURNISHED; MATERIAL PREPARATION REQUIRED; MATERIAL FINISH AND MATERIAL COATINGS TO BE FURNISHED; INFORMATION REGARDING CUTS, COPIES, AND HOLES REQUIRED FOR OTHER TRADES; END CONNECTIONS; CAMBER AND OTHER DEVIATION FROM LINE, SPECIAL ERECTION AND/OR INSTALLATION PROCEDURES, INCLUDING REQUIREMENTS FOR TEMPORARY STABILIZATION.
- 120.3 ALL SHOP DRAWING RESUBMITTALS AND RECORD COPY SUBMITTALS SHALL HAVE ALL REVISIONS SUBSEQUENT TO THE PREVIOUS SUBMISSION CLOUDED OR OTHERWISE IDENTIFIED ON THE RESUBMITTED SHEETS. RESUBMITTALS AND RECORD COPY SUBMITTALS WITHOUT IDENTIFICATION OF REVISIONS WILL BE REJECTED WITHOUT REVIEW.
- 120.4 THE CONTRACTOR SHALL NOT DIRECTLY INCORPORATE THE STRUCTURAL DRAWINGS, OR PORTIONS THEREOF, INTO SHOP DRAWINGS OR ERECTION DRAWINGS TO BE SUBMITTED FOR THIS PROJECT WITHOUT FIRST OBTAINING THE EXPRESS WRITTEN PERMISSION OF ATLANTIC ENGINEERING SERVICES. SUBMITTED SHOP DRAWINGS WHICH CONTAIN COPIES OR REPRODUCTIONS OF ANY PORTION OF THE STRUCTURAL DRAWINGS WITHOUT THE EXPRESS WRITTEN PERMISSION OF ATLANTIC ENGINEERING SERVICES WILL BE RETURNED REJECTED. PERMISSION FOR A SPECIFIC CONTRACTOR OR SUB-CONTRACTOR TO USE PORTIONS OF THE STRUCTURAL DRAWINGS IN THEIR PREPARATION OF SHOP DRAWINGS REQUIRES THAT CONTRACTOR OR SUB-CONTRACTOR TO ENTER INTO A WRITTEN AGREEMENT WITH ATLANTIC ENGINEERING SERVICES AND TO PAY A SERVICE FEE. SUCH AGREEMENT IS NON-TRANSFERABLE AND IS EXTENDED ONLY TO THAT CONTRACTOR FOR THE DURATION OF THIS PROJECT.
- 120.5 THE CONTRACTOR SHALL SUBMIT ELECTRONIC OR PRINTED COPIES OF SHOP DRAWINGS (ELECTRONIC COPIES ARE PREFERRED). COPIES SHALL BE SUBMITTED TO ATLANTIC ENGINEERING SERVICES IN PDF FILE FORMAT (ISO 32000-1), WITH ONE (1) ELECTRONIC FILE PER SUBMISSION. ATLANTIC ENGINEERING SERVICES WILL REVIEW, ANNOTATE, AND RETURN ONE (1) FILE TO THE ARCHITECT FOR THEIR REVIEW AND DISTRIBUTION TO THE CONTRACTOR.
- 120.6 THE REVIEW OF SHOP DRAWINGS AND OTHER SUBMITTALS FOR THIS PROJECT IS FOR CONFORMANCE WITH THE DESIGN CONCEPT AND FOR GENERAL COMPLIANCE WITH THE INFORMATION CONTAINED IN THE CONTRACT DOCUMENTS. COMMENTS REGARDING THESE SUBMITTALS DO NOT RELIEVE THE CONTRACTOR FROM COMPLIANCE WITH THE CONTRACT DOCUMENTS. THE CONTRACTOR IS RESPONSIBLE FOR PERFORMING HIS WORK IN A SAFE AND SATISFACTORY MANNER.

200. FOUNDATIONS - GENERAL
- 200.1 THE CONTRACTOR SHALL OBSERVE WATER CONDITIONS AT THE SITE AND TAKE THE NECESSARY PRECAUTIONS TO ENSURE THAT THE FOUNDATION EXCAVATIONS REMAIN DRY DURING CONSTRUCTION. PROVIDE FOR DEWATERING AS NECESSARY.
- 200.2 THE CONTRACTOR SHALL USE EXTREME CAUTION DURING EXCAVATION. SUCH EXCAVATION SHALL BE PERFORMED IN SUCH A MANNER AS TO MAINTAIN THE STRUCTURAL INTEGRITY OF ALL EXISTING STRUCTURES TO REMAIN. PROVIDE TEMPORARY SHORING AS REQUIRED.
220. AUGER PIER FOUNDATIONS
- 220.1 CAST IN PLACE CONCRETE AUGER PIERS HAVE BEEN DESIGNED TO BEAR ON CAPROCK WITH AN ALLOWABLE END BEARING CAPACITY OF 5000 PSF AND AN ALLOWABLE SIDE FRICTION CAPACITY OF 5000 PSF.
- 220.2 THE CONTRACTOR SHALL RETAIN THE SERVICES OF A PROFESSIONAL GEOTECHNICAL ENGINEER TO PROVIDE A SIGNED AND SEALED CERTIFICATION THAT THE MATERIAL IN WHICH THE PIERS ARE INSTALLED HAS AT LEAST THE ABOVE NOTED END BEARING AND SIDE FRICTION CAPACITIES.
300. REINFORCED CONCRETE
- 300.1 ALL REINFORCED CONCRETE WORK SHALL BE IN CONFORMANCE WITH THE "BUILDING CODE REQUIREMENTS FOR STRUCTURAL CONCRETE" (ACI 318, LATEST EDITION) AND SPECIFICATIONS FOR STRUCTURAL CONCRETE (ACI 301, LATEST EDITION) OF THE AMERICAN CONCRETE INSTITUTE.
- 300.2 MINIMUM DESIGN COMPRESSION STRENGTH (F'_c) REQUIRED AT 28 DAYS:
- A. PIERS, WALLS AND SUMP PITS _____ 4000 PSI
- 300.3 MAXIMUM WATER TO CEMENTITIOUS MATERIALS RATIO:
- A. PIERS, WALLS AND SUMP PITS WITH 2 1/2" GALLONS OF CORROSION INHIBITOR PER CUBIC YARD _____ 0.56
- 300.4 ALL CONCRETE SHALL BE NORMAL WEIGHT CONCRETE (MINIMUM 144 PCF) WITH ALL CEMENT CONFORMING TO ASTM C150, TYPE I, II OR III. MAXIMUM AGGREGATE SIZE SHALL BE 1-1/2" FOR FOOTINGS AND GRADE BEAMS AND 3/4" FOR WALLS AND SLABS, CONFORMING TO ASTM C33.
- 300.5 THE CONTRACTOR SHALL BE PERMITTED TO FURNISH CONCRETE MIXES UTILIZING PORTLAND CEMENT OR BLENDED HYDRAULIC CEMENT SUPPLEMENTED WITH FLY ASH, NATURAL POZZOLAN, SLAG CEMENT AND/OR SILICA FUME CONFORMING TO THE SPECIFICATION REQUIREMENTS OF TABLE 28.4.1.1.1 (a) IN ACI 318.
- 300.6 MIXING WATER SHALL CONFORM TO ASTM C1602.
- 300.7 ADMIXTURES SHALL CONFORM TO THE REQUIREMENTS OF SECTION 28.4.1.4.1 OF ACI 318.
- 300.8 ADMIXTURES SHALL NOT CONTAIN CALCIUM CHLORIDE OR CHLORIDE-CONTAINING COMPOUNDS AS A FUNCTIONAL INGREDIENT.
- 300.9 LIMIT WATER SOLUBLE CHLORIDE ION CONTENT IN CONCRETE FROM ALL SOURCES TO 0.15 PERCENT BY WEIGHT OF CEMENT FOR NONPRESTRESSED CONCRETE
- 300.10 REINFORCEMENT
- A. DEFORMED BARS _____ ASTM A615, GRADE 60
- 300.11 COVER FOR CAST-IN-PLACE CONCRETE REINF., UNLESS OTHERWISE SHOWN ON DRAWINGS, SHALL BE AS FOLLOWS (REFER TO ACI 117 FOR ALLOWABLE CONSTRUCTION TOLERANCES):
- A. AUGER PIERS _____ 3"
- 300.12 SPLICES IN REINFORCEMENT, WHERE PERMITTED, SHALL BE AS FOLLOWS:
- A. WELDED WIRE REINFORCING _____ 8"
- B. ALL OTHERS _____ CLASS "B" TENSION, CASE "1" MINIMUM, UNO
- 300.13 CLASS "B", CASE "1" TENSION SPLICES IN INCHES, SHALL BE AS FOLLOWS:
- | | 4000 PSI | |
|----------|----------|------------|
| SIZE | TOP BARS | ALL OTHERS |
| #3 (#10) | 24 | 19 |
| #4 (#13) | 32 | 25 |
| #5 (#16) | 40 | 31 |
| #6 (#19) | 48 | 37 |
- 300.14 ALL REINFORCING SHALL BE HELD SECURELY IN POSITION WITH STANDARD ACCESSORIES DURING PLACEMENT OF CONCRETE. REINFORCING SUPPORTS FOR ALL EXPOSED CONCRETE SHALL BE GALVANIZED WITH PLASTIC COATED FEET. ALL WELDED WIRE REINFORCING SHALL BE CHAIRD.
- 300.15 ALL TIES/STIRRUPS SHALL HAVE 135 DEGREE BENDS UNLESS OTHERWISE APPROVED BY ENGINEER.
- 300.16 PRIOR TO CONCRETE PLACEMENT, THE CONTRACTOR SHALL SUBMIT A CONCRETE MIX DESIGN PREPARED IN ACCORDANCE WITH ACI 301 TO THE STRUCTURAL ENGINEER FOR REVIEW.
- 300.17 THE CONTRACTOR SHALL ENGAGE A QUALIFIED INDEPENDENT TESTING LABORATORY, SUBJECT TO THE APPROVAL OF THE OWNER, TO SAMPLE AND TEST CONCRETE AT THE POINT OF PLACEMENT PER ACI 301. A COPY OF THE TEST RESULTS SHALL BE PROVIDED TO THE OWNER AND ENGINEER. TESTING SHALL INCLUDE AT LEAST THE FOLLOWING:
- A. RECORD THE TEMPERATURE AND PERFORM ONE SLUMP TEST PER ASTM C 143 FOR EACH 10 CY OF CONCRETE PLACED.
- B. CAST AND LABORATORY CURE SIX (6) CONCRETE COMPRESSIVE STRENGTH TEST CYLINDERS IN ACCORDANCE WITH ASTM C 31 FOR EACH 50 CY OF EACH CLASS OF CONCRETE OR FRACTION THEREOF PLACED PER DAY. TEST (IN ACCORDANCE WITH ASTM C 39) TWO (2) CYLINDERS AT 7 DAYS, TWO (2) CYLINDERS AT 28 DAYS AND RETAIN TWO (2) CYLINDERS FOR TESTING AT 56 DAYS IN THE EVENT THE 28 DAY CYLINDERS DO NOT MEET THE SPECIFIED CONCRETE COMPRESSIVE STRENGTH.

350. CONCRETE/MASONRY ANCHORS
- 350.1 ALL ADHESIVE FOR ANCHORING TO CONCRETE SHALL BE "HILTI HIT-HY 200 ADHESIVE ANCHORS" AS MANUFACTURED BY HILTI FASTENING SYSTEMS, INC. (OR APPROVED EQUIVALENT).
- 350.2 THE "HAS-E THREADED ROD" SHALL CONFORM TO GRADE E 316 STAINLESS STEEL WITH A MINIMUM TENSILE STRENGTH OF 75 KSI. THE NUT SHALL CONFORM GRADE E 316 STAINLESS STEEL.
- 350.3 THE SPACING AND MINIMUM EMBEDMENT OF POST-INSTALLED ANCHORS SHALL BE AS INDICATED ON DRAWINGS. THE INSTALLATION OF THE ANCHORS SHALL BE IN ACCORDANCE WITH THE MANUFACTURER'S RECOMMENDED PROCEDURES.
420. MASONRY
- 420.1 ALL MASONRY WORK SHALL BE IN CONFORMANCE WITH THE LATEST EDITION OF "BUILDING CODE REQUIREMENTS FOR MASONRY STRUCTURES" (TMS 402/ACI 530/ASCE 5) AND THE "SPECIFICATIONS FOR MASONRY STRUCTURES" (TMS 602/ACI 530.1/ASCE 6) OF THE MASONRY SOCIETY.
- 420.2 ALL MASONRY WORK TO BE EXECUTED IN COLD WEATHER SHALL BE IN CONFORMANCE WITH THE RECOMMENDATIONS FOR COLD WEATHER CONSTRUCTION OF THE LATEST EDITION OF "BUILDING CODE REQUIREMENTS FOR MASONRY STRUCTURES" (TMS 402/ACI 530/ASCE 5) AND THE "SPECIFICATIONS FOR MASONRY STRUCTURES" (TMS 602/ACI 530.1/ASCE 6) OF THE MASONRY SOCIETY WITH THE FOLLOWING ADDITION TO THE REQUIREMENTS OF TMS 602/ACI 530.1/ASCE 6, SECTION 1.8-C: FOR ALL CONDITIONS WHEN TEMPERATURES FALL BELOW 40 DEGREES F, THE TEMPERATURE OF THE NEWLY LAID MASONRY OR NEWLY GROUTED MASONRY SHALL BE MAINTAINED ABOVE 32 DEGREES (F) FOR A MINIMUM OF 24 HOURS USING THE METHODS DESCRIBED IN TMS 602/ACI 530.1/ASCE 6.
- 420.3 MORTAR SHALL CONFORM TO THE PROPORTION SPECIFICATION OF ASTM C270, TYPE M OR S. PROVIDE TYPE M MORTAR AT ALL HIGH STRENGTH MASONRY NOTED AS F'_m = 2500 PSI OR GREATER. PROVIDE TYPE S MORTAR AT ALL STRUCTURAL MASONRY AND REINFORCED MASONRY UNLESS NOTED OTHERWISE.
- 420.4 GROUT SHALL CONFORM TO ASTM C476 AND AS FOLLOWS:
- A. COMPRESSIVE STRENGTH (F'_c) OF GROUT = F'_m AS INDICATED BELOW BUT NO LESS THAN 3,000 PSI.
- B. SLUMP OF GROUT SHALL BE 8 TO 11 INCHES AS MEASURED ACCORDING TO ASTM C143.
- C. MAX. AGGREGATE SIZE SHALL BE 3/8" (AGGREGATE GRADED TO PRODUCE FINE GROUT IN CONFORMANCE WITH ASTM C476 AND C404).
- 420.5 LIMIT CEMENTITIOUS MATERIALS IN MORTAR TO: PORTLAND CEMENT CONFORMING TO ASTM C150 TYPE I; LIME CONFORMING TO ASTM C207; MORTAR CEMENT CONFORMING TO ASTM C1329; AND MASONRY CEMENT CONFORMING TO ASTM C91.
- 420.6 PROVIDE SOLID AND HOLLOW LOAD BEARING CONCRETE BLOCK UNITS CONFORMING TO ASTM C90. FURNISH CONCRETE BLOCK WITH NET AREA COMPRESSIVE STRENGTH AS SPECIFIED BY TABLE 2 OF TMS 602/ACI 530.1/ASCE 6, SECTION 1.4 B.2 BASED ON THE UNIT STRENGTH METHOD.
- 420.7 MINIMUM 28-DAY ULTIMATE COMPRESSIVE STRENGTH OF MASONRY:
- A. F'_m _____ 2000 PSI
- 420.8 FULL BED AND HEAD JOINTS SHALL BE USED.
- 420.9 GROUT SOLID ALL CELLS IN MASONRY UNITS INSTALLED BELOW GRADE.
- 420.10 GROUT SOLID ALL CELLS CONTAINING REINFORCING, AND WHERE INDICATED ON PLANS AND SECTIONS.
- 420.11 PROVIDE FINE GROUT PER ASTM C476 WHEN WIDTH OF GROUT SPACE IS LESS THAN 2". PROVIDE COARSE GROUT FOR GROUT SPACE WIDTHS 2" OR GREATER. PROVIDE FINE GROUT WHEN REINFORCING HAS LESS THAN 1/2" CLEARANCE.
- 420.12 DEFORMED BAR REINFORCEMENT SHALL CONFORM TO ASTM A615, GRADE 60. PROVIDE LAP SPLICES PER THE TABLE BELOW. PROVIDE BAR SPACERS AS REQUIRED TO PROPERLY LOCATE REINFORCING.
- | | |
|----------|-----|
| #3 (#10) | 15" |
| #4 (#13) | 20" |
| #5 (#16) | 25" |
| #6 (#19) | 30" |
- 420.13 AT MASONRY PIERS AND COLUMNS WHERE TIES ARE INDICATED, PROVIDE MULTIPLE TIES SETS AS REQUIRED, MATCHING THE SIZE AND SPACING INDICATED, TO MEET THE TIE REQUIREMENTS PER ACI 530 FOR BAR CONFINEMENT AND LATERAL SUPPORT.
- 420.14 BRICK VENEER ANCHORS SHALL BE PROVIDED PER ACI 530 AND SHALL BE SPACED NOT MORE THAN 16" O.C. HORIZONTALLY OR VERTICALLY WITH ADDITIONAL ANCHORS PROVIDED WITHIN 8" OF OPENINGS AND SPACED NOT MORE THAN 16" AROUND PERIMETER.

610. STRUCTURAL LUMBER
- 610.1 ALL STRUCTURAL LUMBER WORK SHALL BE IN ACCORDANCE WITH THE "NATIONAL DESIGN SPECIFICATION FOR WOOD CONSTRUCTION" (NDS - LATEST EDITION) PUBLISHED BY THE AMERICAN WOOD COUNCIL.
- 610.2 ALL STRUCTURAL LUMBER SHALL BE AS A MINIMUM NO. 2 GRADE SOUTHERN PINE PRESSURE TREATED AND SHALL HAVE AT LEAST THE FOLLOWING MINIMUM ALLOWABLE DESIGN STRESSES (NOT INCORPORATING THE SIZE ADJUSTMENT FACTOR (C_F)) AND MODULUS OF ELASTICITY AT A MAXIMUM MOISTURE CONTENT OF 19%:
- | | |
|------------------------|---------------|
| A. F_b (BENDING) | 750 PSI |
| B. F_v (SHEAR) | 175 PSI |
| C. F_c (COMPRESSION) | 1,250 PSI |
| D. F_t (TENSION) | 450 PSI |
| E. E | 1,400,000 PSI |
- 610.3 ALL LUMBER SHALL COMPLY WITH PS 20 "AMERICAN SOFTWOOD LUMBER STANDARD" AND WITH THE APPLICABLE RULE OF INSPECTION AGENCIES CERTIFIED BY AMERICAN LUMBER STANDARD. FACTORY-MARK EACH PIECE OF LUMBER WITH GRADE STAMP OF INSPECTION AGENCY EVIDENCING COMPLIANCE WITH GRADING RULE REQUIREMENTS.
- 610.4 STRUCTURAL STEEL PLATES, ANGLES, ETC., SHALL BE 316 STAINLESS STEEL. CONTRACTOR TO SUBMIT SHOP DRAWINGS ON ALL MISCELLANEOUS METALS FOR REVIEW BY STRUCTURAL ENGINEER.
- 610.5 ALL BOLTS SHALL BE 3/4" DIAMETER 316 STAINLESS STEEL UNLESS NOTED OTHERWISE WITH 2 STAINLESS STEEL WASHERS PER BOLT UNLESS OTHERWISE NOTED.
- 610.6 PRESSURE TREAT WITH WATER-BORNE PRESERVATIVES ALL LUMBER FOR SILL PLATES AND OTHER WOOD WHICH MAY BE EXPOSED TO WEATHER OR EARTH. PRESSURE TREATMENT SHALL COMPLY WITH REQUIREMENTS OF AWPA STANDARDS C2 AND LP-22.
- 610.7 PROVIDE NAILING PATTERN IN COMPLIANCE WITH THE DESIGN BUILDING CODE'S RECOMMENDED FASTENING SCHEDULE WHEN JOINING TWO OR MORE FRAMING MEMBERS.
- 610.8 ALL WOOD JOIST OR HEADERS ENDS WHICH FRAME INTO BEAMS SHALL BE HUNG WITH THE FOLLOWING JOISTS HANGERS, AS MANUFACTURED BY SIMPSON STRONG-TIE COMPANY, INC. OR WITH APPROVED SUBSTITUTES WITH THE FOLLOWING WORKING LOAD CAPACITIES.
- | JOIST SIZE | SIMPSON HANGER | LOAD CAPACITY |
|------------|----------------|---------------|
| 2X6 | U26 | 705 LBS. |
| 2X8 | U26 | 705 LBS. |
| 2X10 | U210 | 1,175 LBS. |
| 2X12 | U210 | 1,175 LBS. |
| 2-2X6 | HU26-2 | 990 LBS. |
| 2-2X8 | HU28-2 | 1,303 LBS. |
| 2-2X10 | HU210-2 | 1,666 LBS. |
| 2-2X12 | HU212-2 | 2,016 LBS. |
- 610.9 ALL WOOD CONNECTORS SHALL BE HOT-DIPPED GALVANIZED OR STAINLESS STEEL. ALL NAILS AND SCREWS SHALL BE STAINLESS STEEL.
620. STRUCTURAL WOOD PANELS/WOOD SHEATHING
- 620.1 FURNISH PANELS THAT ARE EACH FACTORY MARKED WITH A CERTIFICATION STAMP EVIDENCING COMPLIANCE WITH GRADE AND SPAN RATING REQUIREMENTS. THE CENTER-TO-CENTER SPACING IN INCHES SHALL NOT EXCEED THE SPAN RATING STAMPED ON THE PANELS. INSTALLATION OF THE PANELS SHALL BE IN ACCORDANCE WITH THE RECOMMENDATIONS OF THE APA.
- 620.2 PANELS SHALL COMPLY WITH USDOC PS-1 OR PS-2 AND APA PRP-108 AND SHALL MEET THE FOLLOWING REQUIREMENTS:
- A. ROOF:
- MIN. THICKNESS = 3/4"
 - BOND CLASSIFICATION = EXPOSURE 1 EXTERIOR
 - GRADE = APA RATED SHEATHING STRUCTURAL I
 - SPAN RATING = AS REQUIRED TO SUIT JOIST/TRUSS SPACING
- 620.3 ALL PANELS WHICH HAVE ANY EDGE OR FACE PERMANENTLY EXPOSED TO THE WEATHER SHALL BE CLASSED EXTERIOR, EXCEPT OPEN SOFFITS OR ROOF SHEATHING EXPOSED ON THE UNDERSIDE MAY BE CLASSED EXPOSURE 1.
- 620.4 THE USE OF ORIENTED STRAND BOARD STRUCTURAL PANELS IN FLOOR CONSTRUCTION IS PROHIBITED UNLESS APPROVED BY THE ARCHITECT.
- 620.5 ALL ROOF STRUCTURAL PANELS SHALL BE NAILED WITH 10D RING SHANK STAINLESS STEEL NAILS AT 6" ON CENTER AT ALL ENDS AND EDGES AND AT 6" ON CENTER AT ALL INTERMEDIATE SUPPORTS.
- 620.6 ALL PLYWOOD PANELS SHALL COMPLY WITH THE WIND UPLIFT REQUIREMENTS OF NMS19 FOR FULLY-WIND-RESISTIVE ROOF ASSEMBLIES COMPLYING WITH UL CLASS 90 CLASSIFICATION.

HISTORIC MALLORY SQUARE CABLE HUTS
KEY WEST, FLORIDA

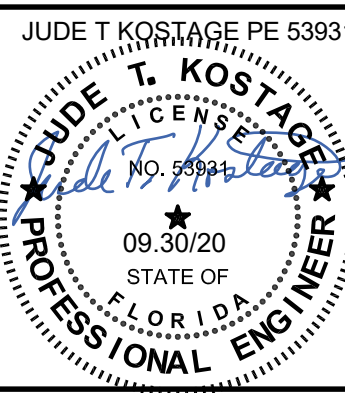

410 Angela Street
Key West, Florida 33040
Telephone (305) 296-1347
Facsimile (305) 296-2727
Florida License AAC002022

Bender & Associates
ARCHITECTS
P.A.

Project No. 1729A
GENERAL NOTES
Date: 09/28/2020

SO.1
OF

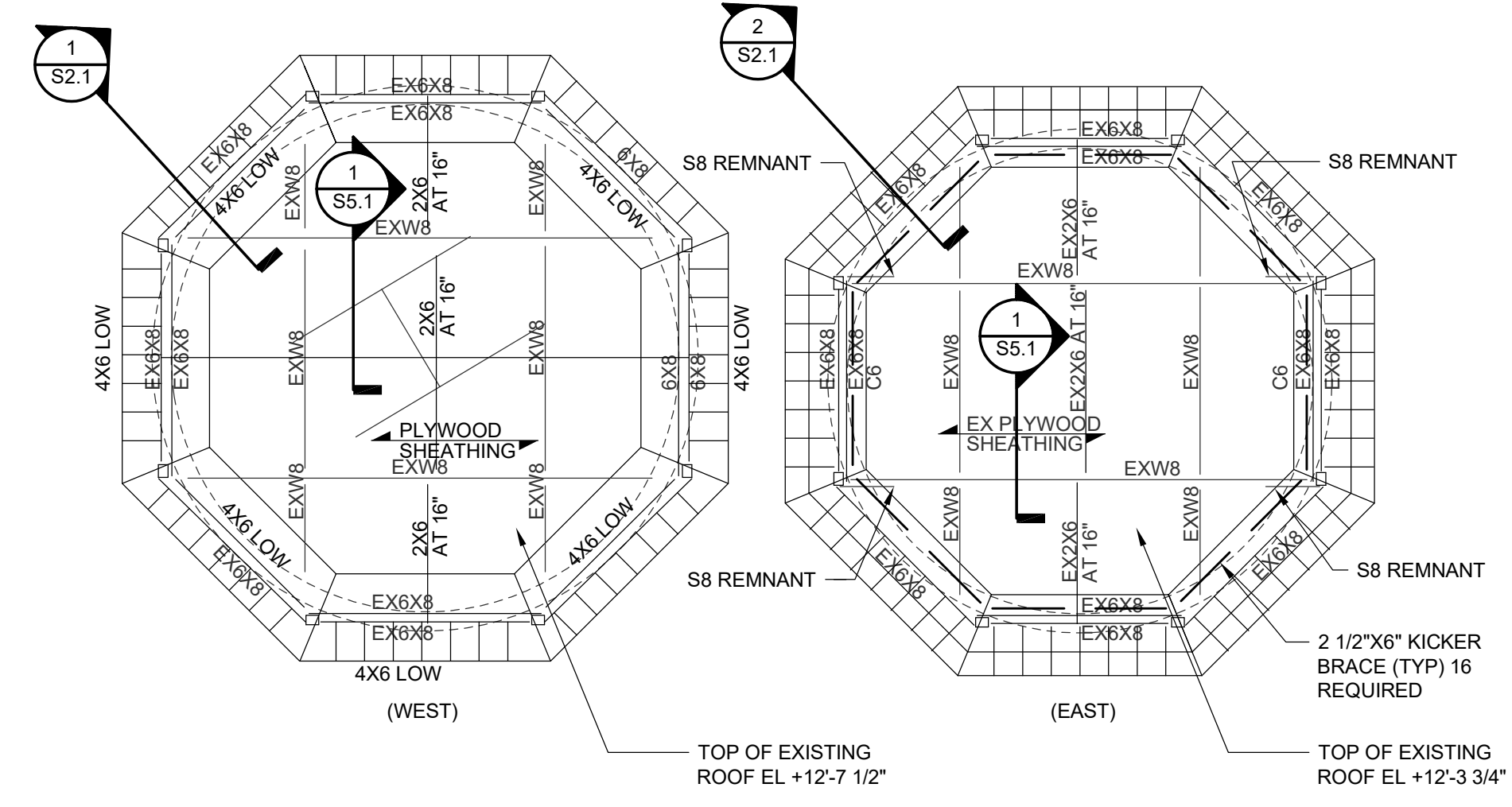
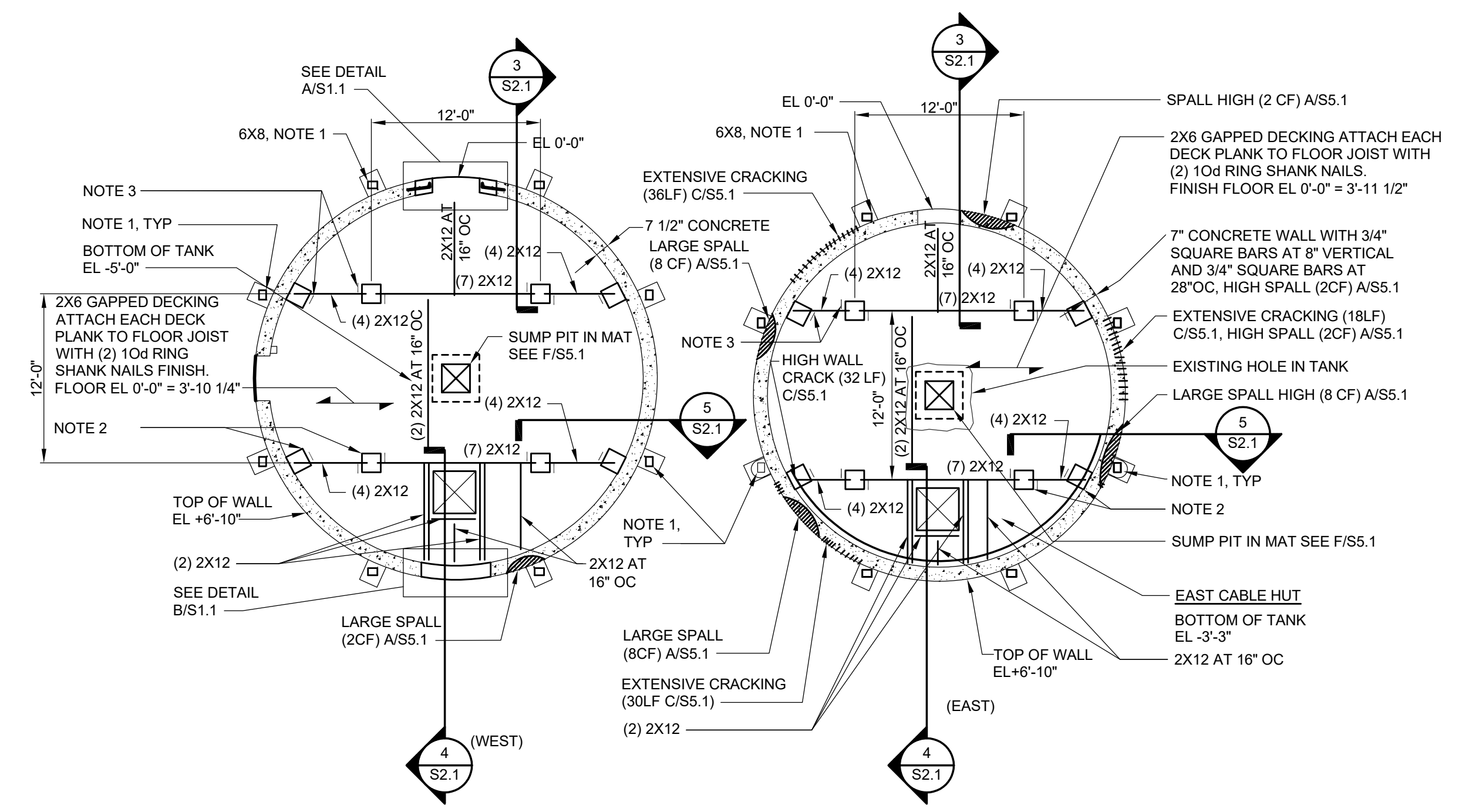
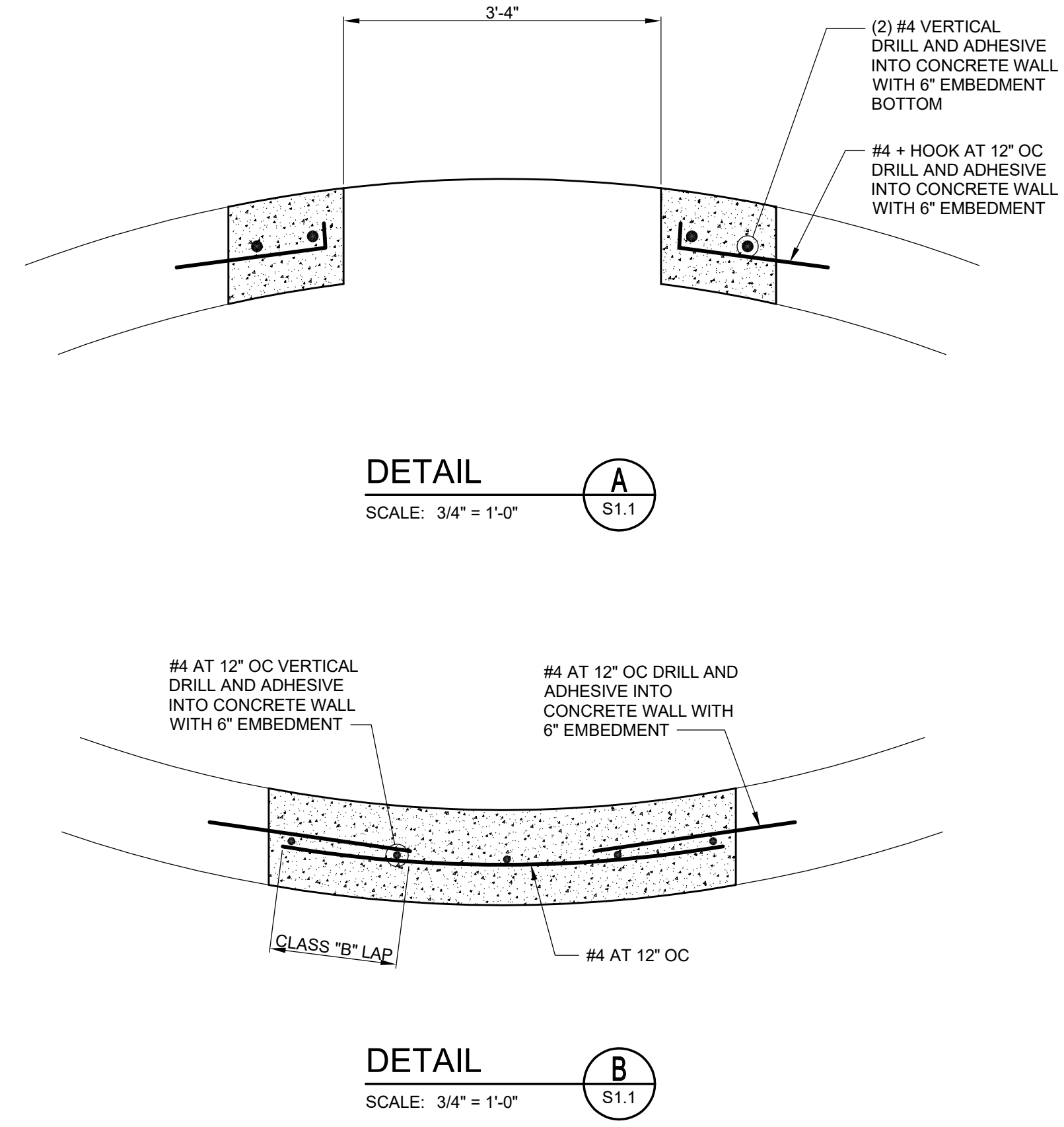

- NOTES:**
- ALL EXISTING PERIMETER 6X8 COLUMNS TO BE PLACED ON NEW CONCRETE PIERS. SEE DETAIL D/S5.1. SHORE ROOF STRUCTURE PRIOR TO COLUMN MODIFICATION. CONTRACTOR TO PREPARE AND SUBMIT A SHORING PLAN TO THE ARCHITECT AND ENGINEER FOR REVIEW AND ACCEPTANCE. COLUMN ALLOWABLE SHORING REACTION 7000#.
 - 16"X16" MASONRY PIER WITH (4) #5 VERTICAL DRILL AND ADHESIVE INTO CONCRETE MAT WITH 6" EMBEDMENT. FILL PIER SOLID WITH 3000 PSI GROUT. AT EXTERIOR WALL PROVIDE MASONRY VENEER ANCHOR AT EVERY COURSE.
 - FJA FOUNDATION ANCHOR WITH (2) 1/2" DIA ADHESIVE ANCHORS WITH 6" EMBEDMENT.

This document has been electronically signed and sealed by Jude T. Kostage, PE on 09/30/20 using a Digital Signature. Printed copies of this document are not considered signed and sealed and the signatures must be verified on any electronic copies.

HISTORIC MALLORY SQUARE CABLE HUTS
KEY WEST, FLORIDA

JUDE T. KOSTAGE PE 53931
PROFESSIONAL ENGINEER
STATE OF FLORIDA
09.30.20
No. 55931

410 Angela Street
Key West, Florida 33040
Telephone (305) 296-1347
Facsimile (305) 296-2727
Florida License AAC002022

Bender & Associates ARCHITECTS P.A.

Project N^o 1729A
SLAB / ROOF PLANS AND GENERAL NOTES
Date: 09/28/2020

S1.1
OF

ATLANTIC ENGINEERING SERVICES
6501 Arlington Expressway
Building B, Suite 201
Jacksonville, FL 32211
PH: 904.742.6023 FX: 904.725.9295
315-119-01
FL CCA #791

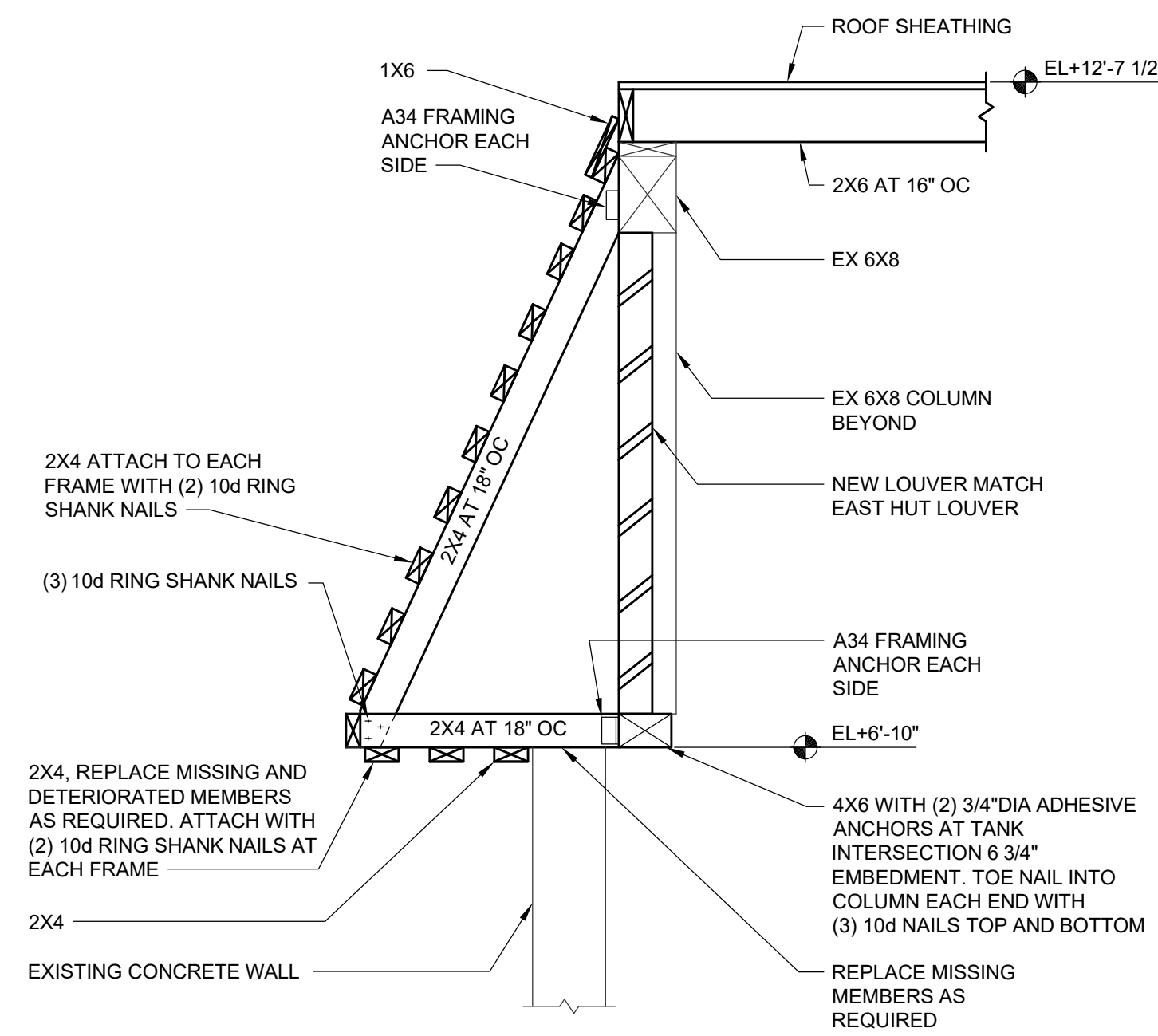

FRAME AT WEST FRAME (AT LOUVER) 1
S2.1

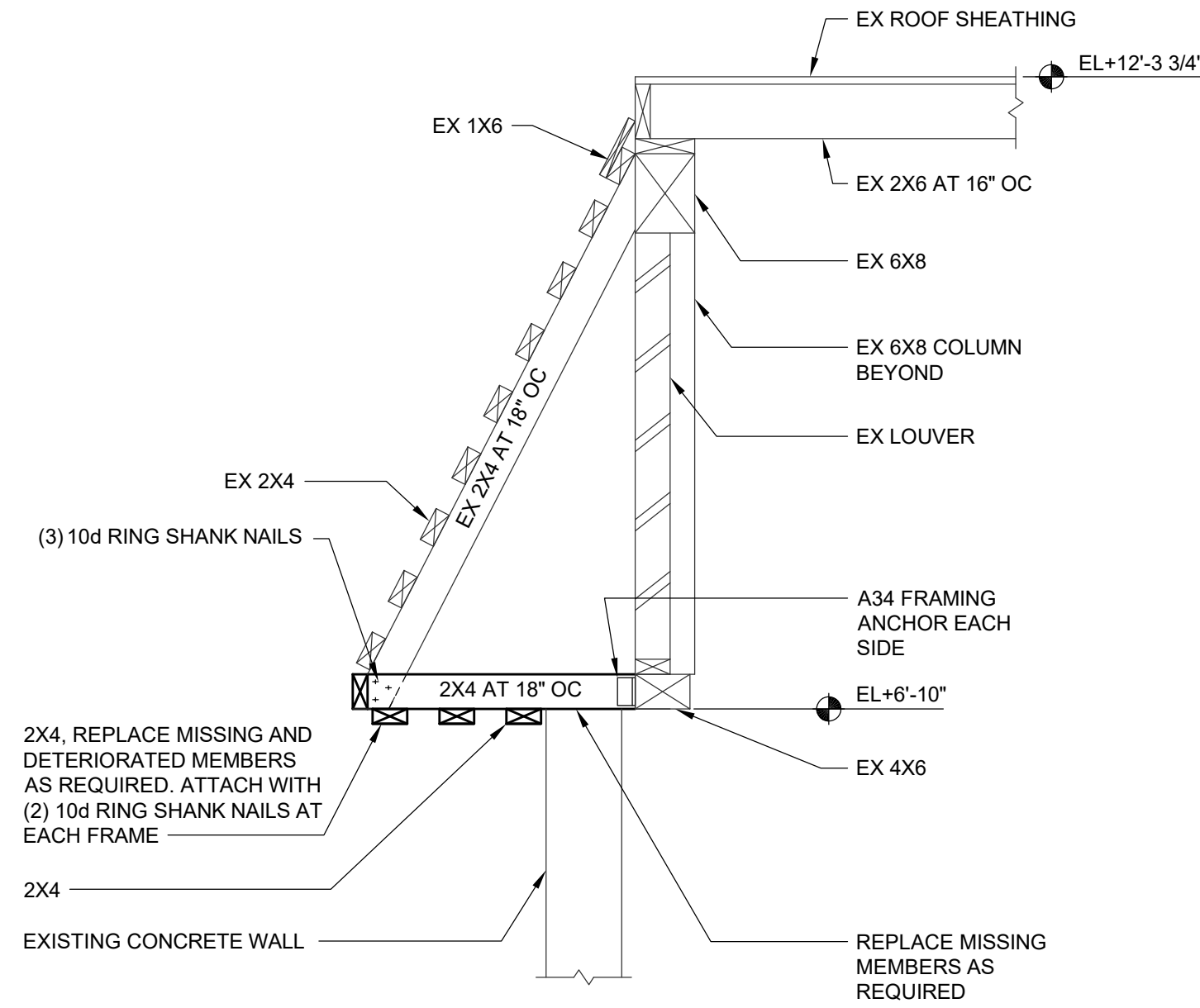

FRAME AT EAST FRAME (AT LOUVER) 2
S2.1

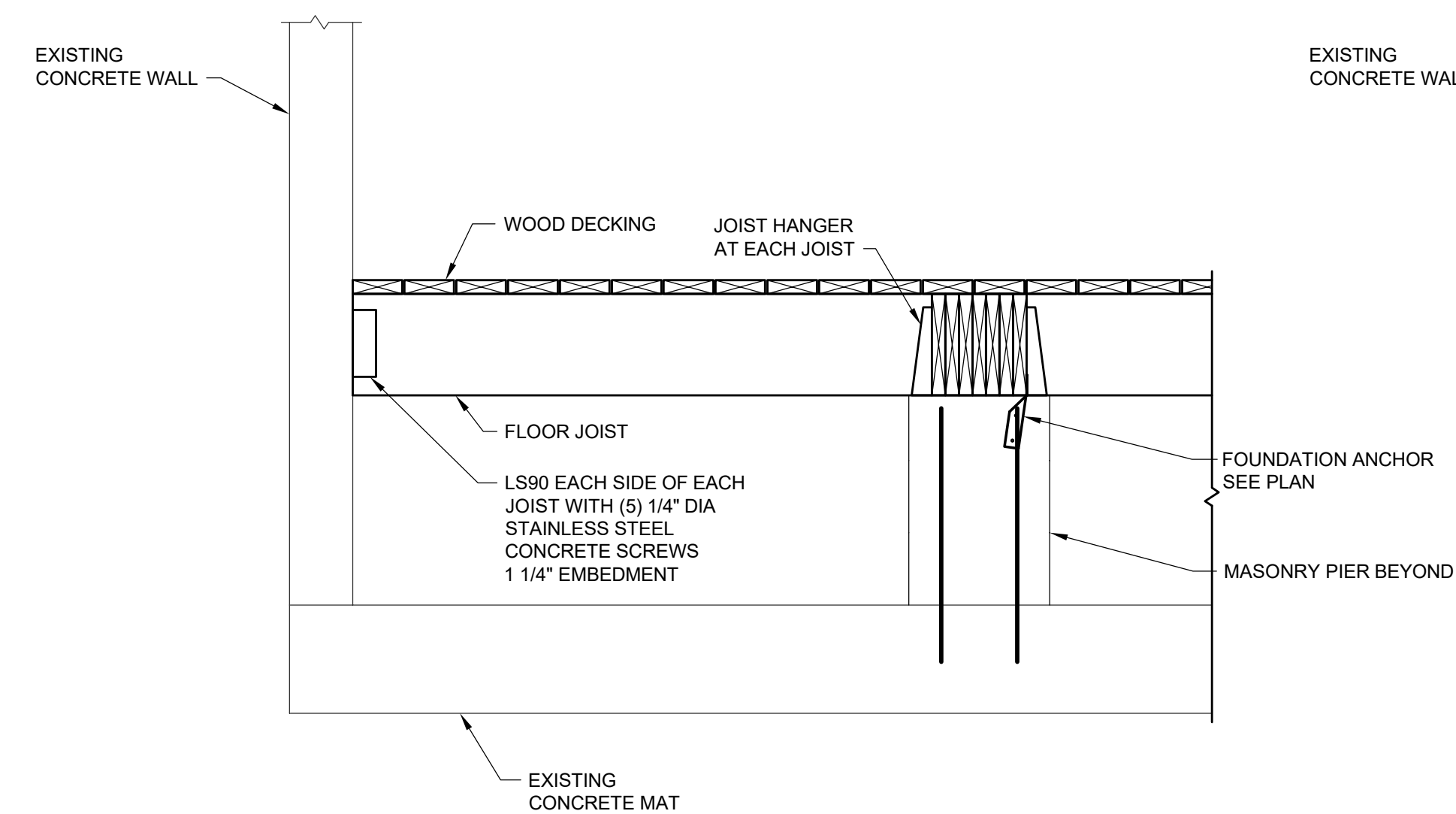

SECTION 3
SCALE: 3/4" = 1'-0" S2.1

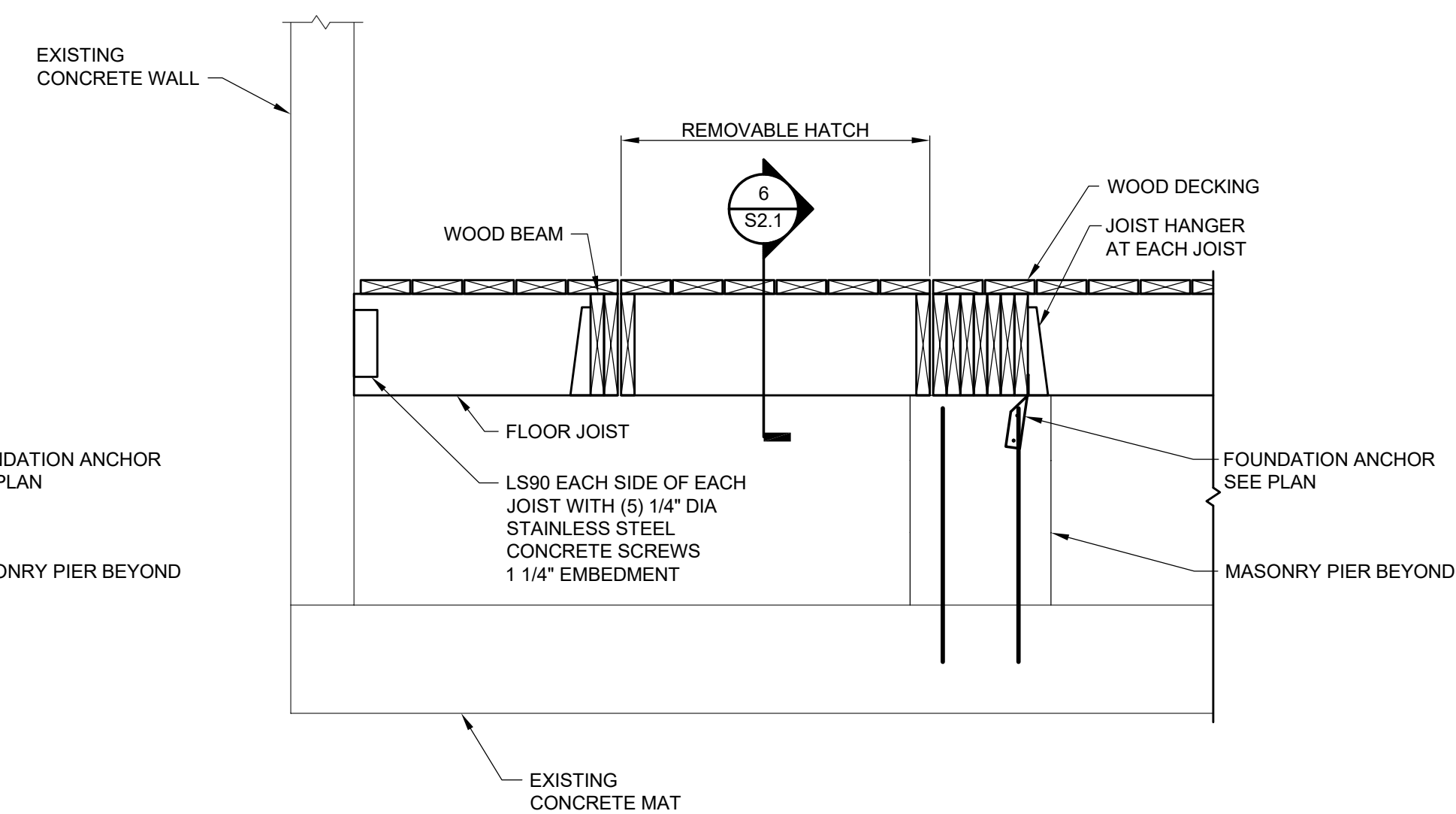

SECTION 4
SCALE: 3/4" = 1'-0" S2.1

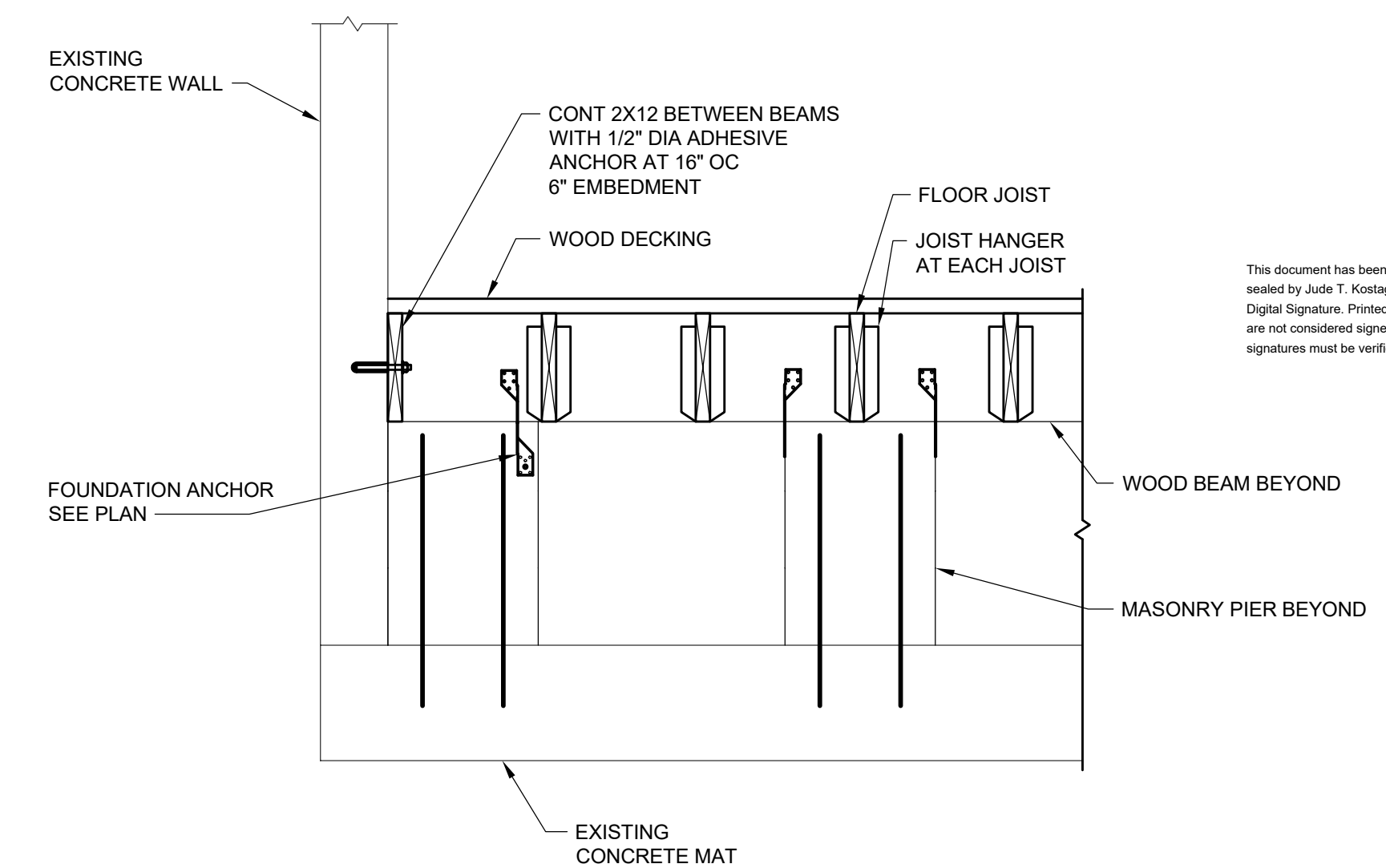

SECTION 5
SCALE: 3/4" = 1'-0" S2.1

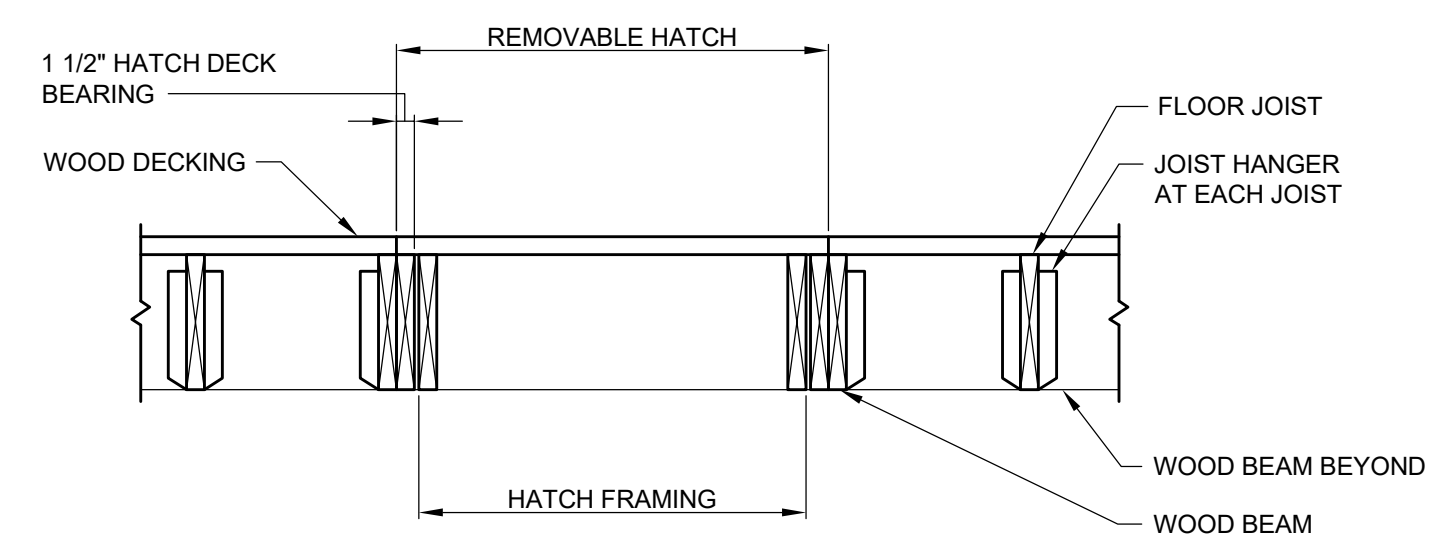

SECTION 6
SCALE: 3/4" = 1'-0" S2.1

This document has been electronically signed and sealed by Jude T. Kostage, PE on 09/30/20 using a Digital Signature. Printed copies of this document are not considered signed and sealed and the signatures must be verified on any electronic copies.

HISTORIC MALLORY
SQUARE CABLE HUTS
KEY WEST, FLORIDA

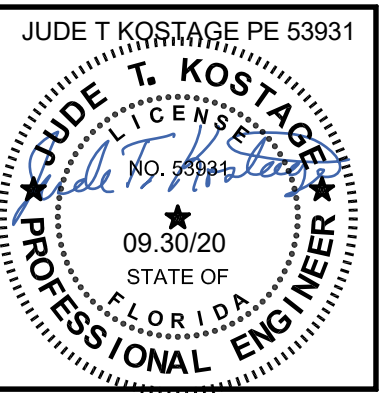

410 Angela Street
Key West, Florida 33040
Telephone (305) 296-1347
Facsimile (305) 296-2727
Florida License AAC002022

Bender & Associates
ARCHITECTS
P.A.

Project N^o 1729A
SECTIONS
Date: 09/28/2020

S2.1
OF



ATLANTIC ENGINEERING SERVICES
6501 Arlington Expressway
Building B, Suite 201
Jacksonville, FL 32211
PH: 904.742.4623 FX: 904.726.9295
315-119-01
FL CCA #791

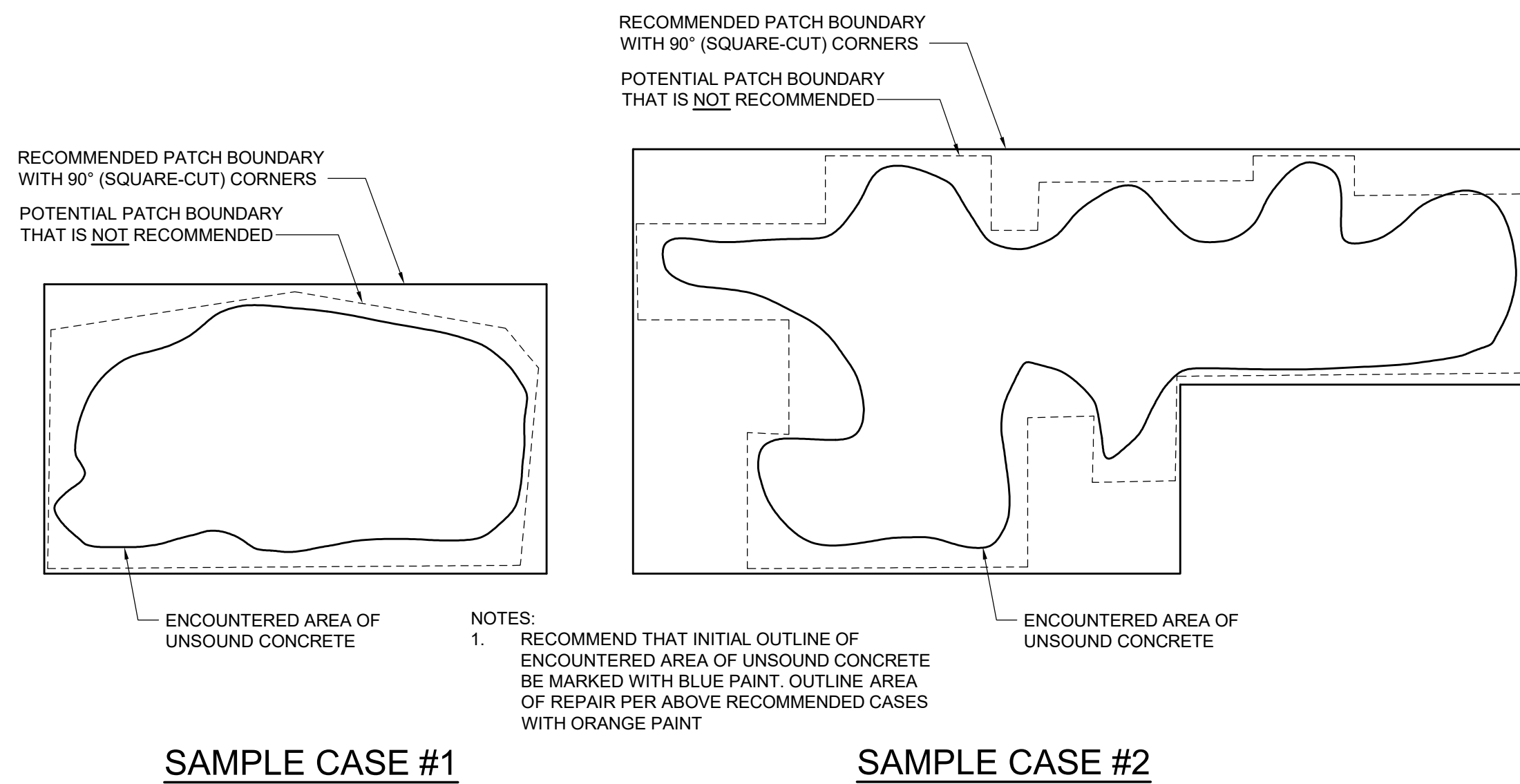

TYPICAL PATCH AREA CONFIGURATION

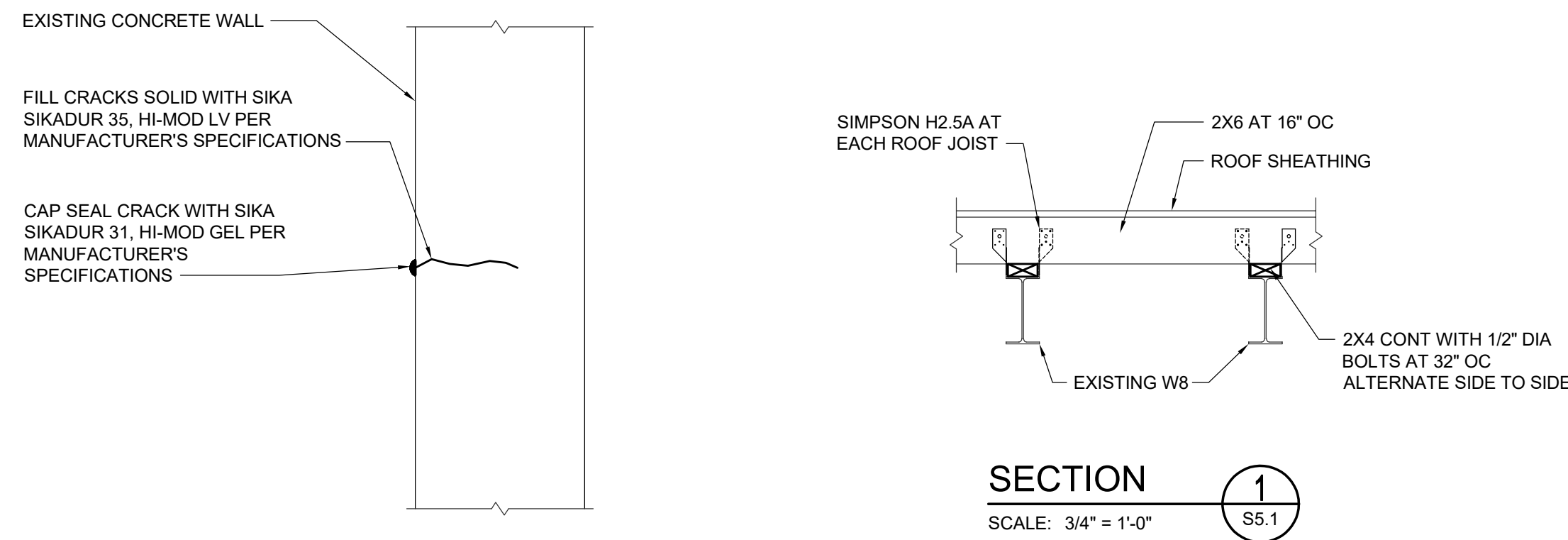

TYPICAL COLUMN/WALL CRACK INJECTION DETAIL

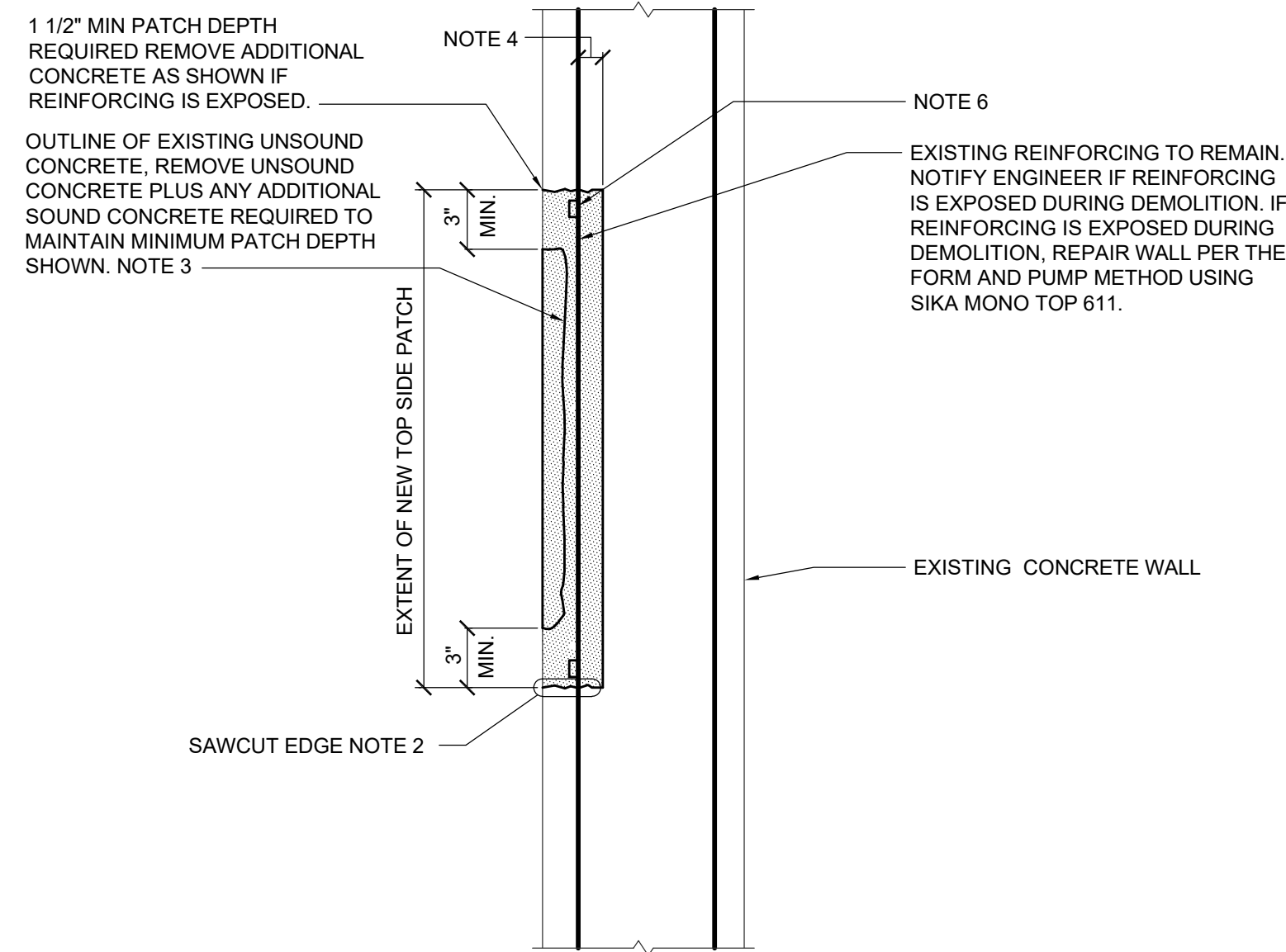
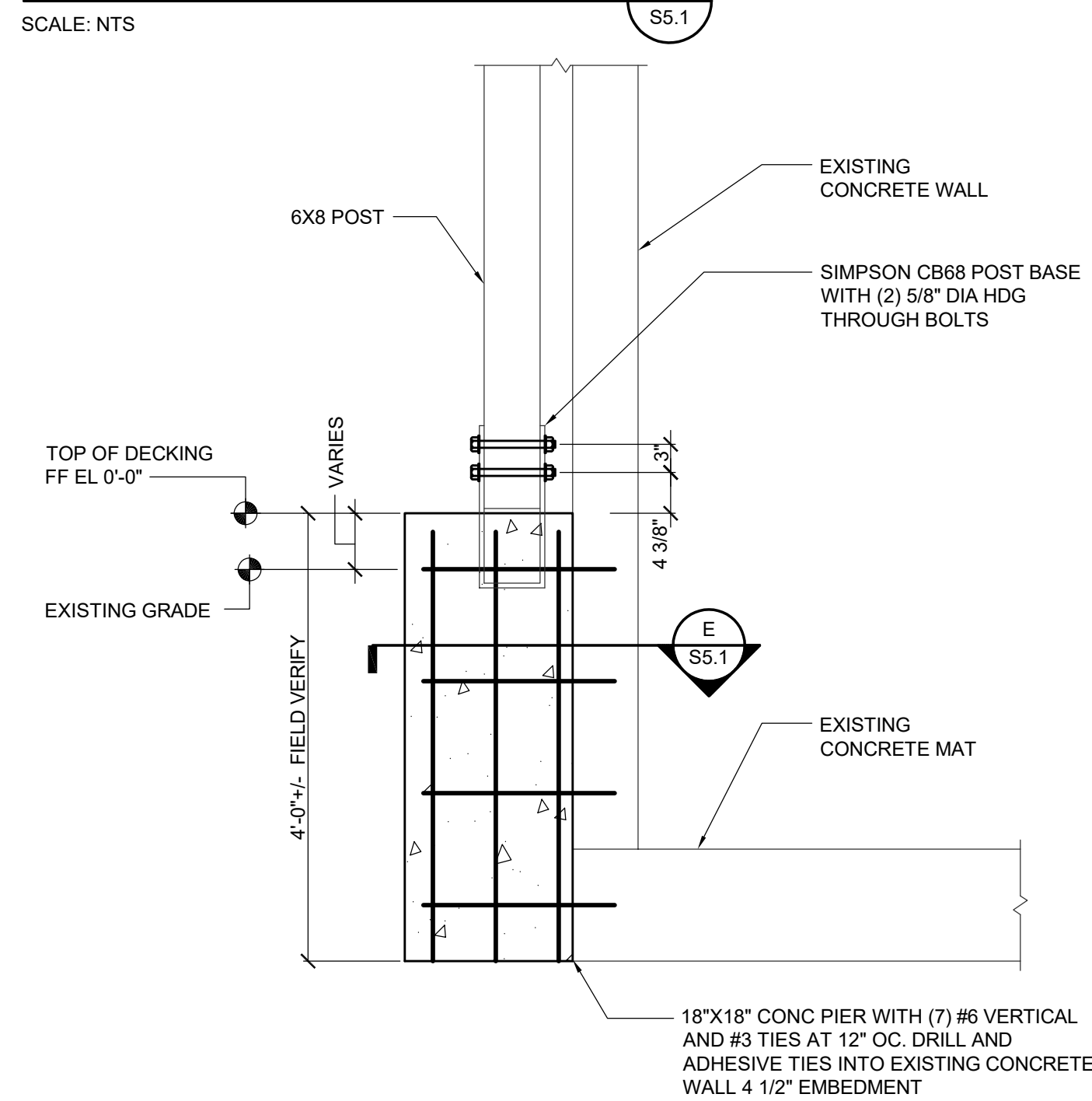

TYPICAL PARTIAL DEPTH CONCRETE WALL REPAIR DETAIL

- SCALE: NTS
- NOTES:
- PRIOR TO BEGINNING REPAIR, OUTLINE EXTENT OF PATCH ON WALL WITH SPRAY PAINT FOR REVIEW BY ENGINEER.
 - SAW CUT EDGES 3" MINIMUM BEYOND LIMITS OF UNSOUND CONCRETE AREAS TO 1/2" MAXIMUM DEPTH. TAKE EXTREME CARE TO AVOID CUTTING REBAR AND TENDONS. SQUARE CUT CORNERS IN PATTERNS AS SIMPLE AS POSSIBLE. SEE TYPICAL PATCH AREA CONFIGURATION DETAIL ON THIS SHEET FOR CONCEPT
 - TROWEL APPLY POLYMER MODIFIED PATCH MORTAR SIKA REPAIR SHB, OR SIKA REPAIR 223 PER MANUFACTURER'S SPECIFICATIONS. FORM AND PUMP WITH SIKA MONOTOP 611 IF REINFORCEMENT IS EXPOSED.
 - 1" MINIMUM CLEARANCE BETWEEN EXPOSED REBAR AND SOUND CONCRETE IF REBAR IS EXPOSED DURING REMOVAL OF UNSOUND CONCRETE.
 - PRIOR TO PLACING PATCH MATERIAL SANDBLAST OR WATER BLAST EXISTING SURFACES AND EXPOSED REINFORCING SURFACES AND REINFORCING SHALL BE CLEAN, SOUND, AND FREE OF CONTAMINANTS. COAT EXPOSED CONCRETE SURFACE AND REINFORCING WITH BONDING AGENT / REINFORCEMENT PROTECTION SIKA ARMATEC 110 PER MANUFACTURER'S SPECIFICATIONS.
 - PROVIDE GALVANIZED ANODES AT EACH AND AT 12" OC OF ALL REINFORCING EXPOSED DURING DEMOLITION. DO NOT COAT OF REBAR WITH SIKA ARMATEC 110 WHERE WIRE LEADS CONNECT TO REINFORCING.
 - PROVIDE TEMPORARY SHORING IF MORE THAN ONE VERTICAL REBAR IS EXPOSED OR MORE THAN 15 PERCENT OF COLUMN SECTION IS REMOVED.

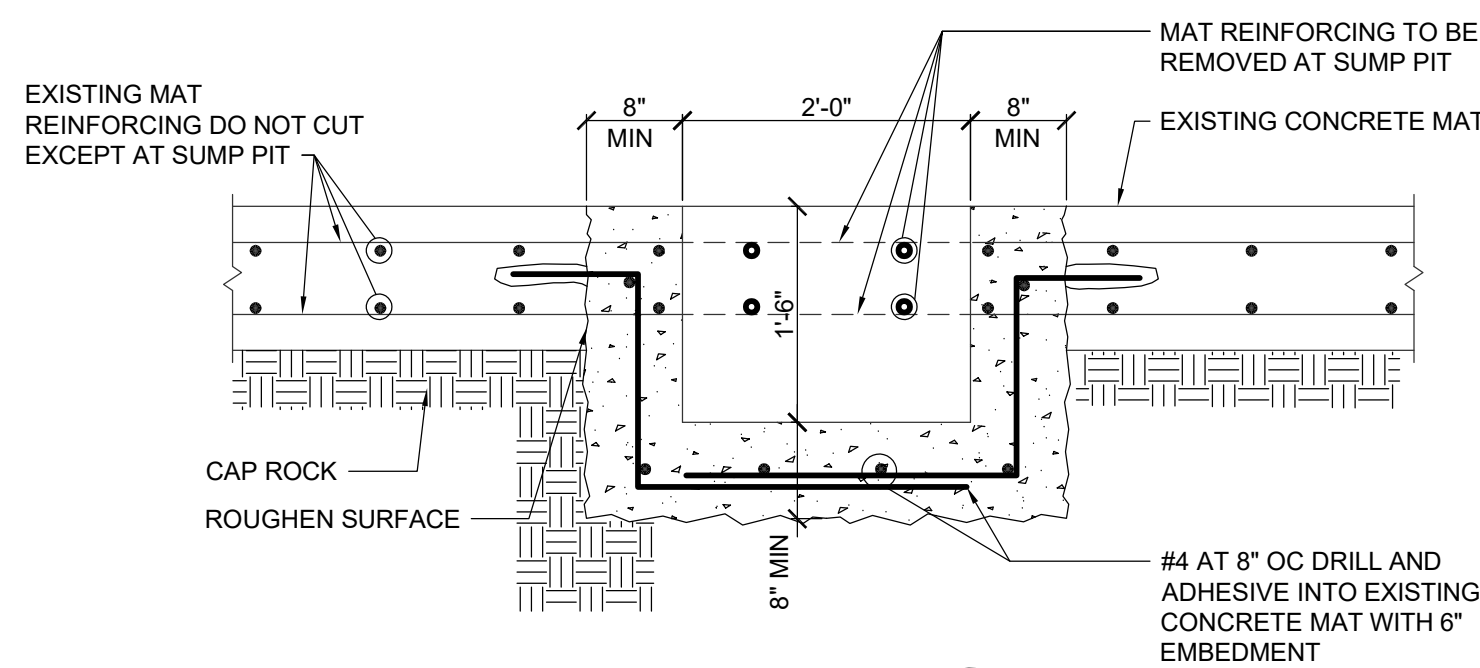
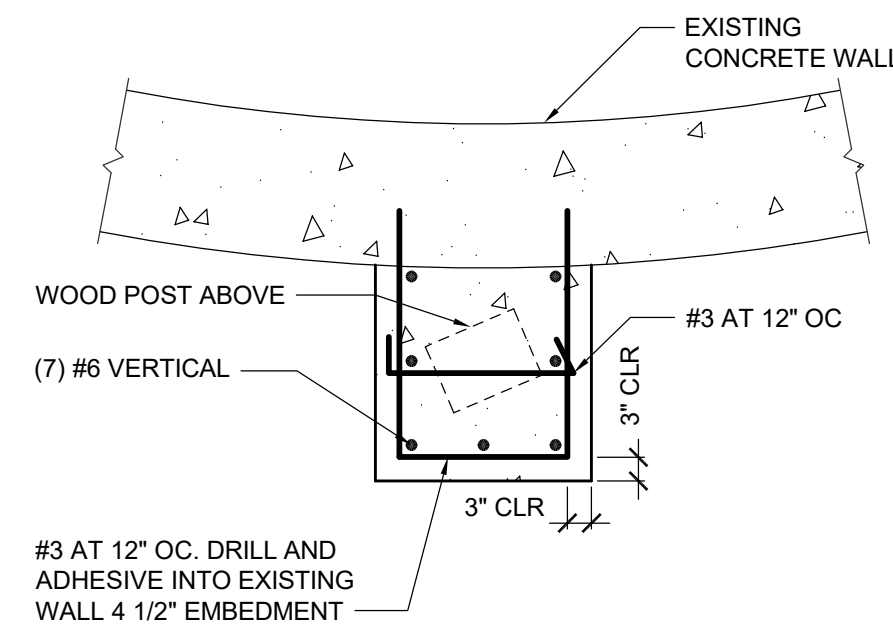

DETAIL F

- SCALE: 3/4" = 1'-0"
- NOTES:
- DEWATER AROUND CABLE HUTS PRIOR TO PLACING SUMP PIT CONCRETE.
 - AS AN ALTERNATE TO DEWATERING AROUND CABLE HUTS, USE TREMIE CONCRETE FOR SUMP PIT CONCRETE PLACED AT LOW TIDE.

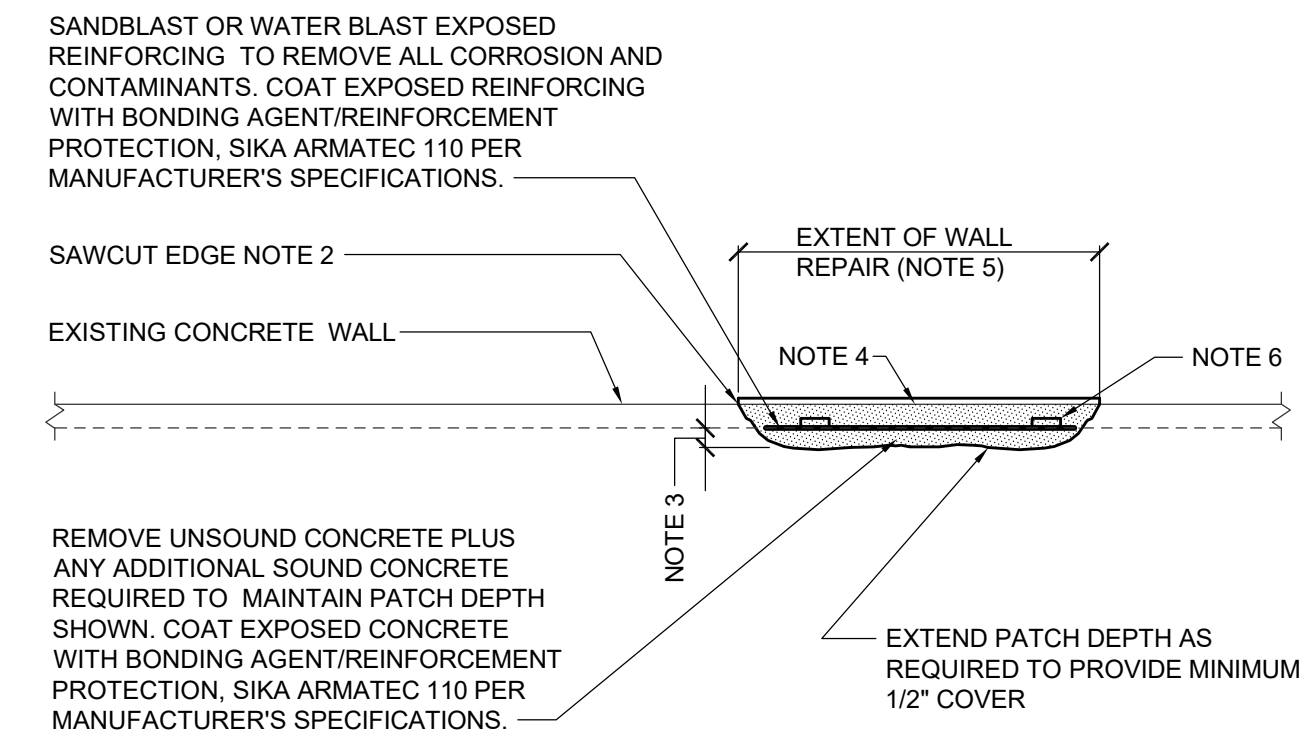

TYPICAL TOP OF WALL CONCRETE REPAIR DETAIL

- SCALE: NTS
- NOTES:
- PRIOR TO BEGINNING REPAIR, OUTLINE EXTENT OF PATCH ON SLAB WITH SPRAY PAINT FOR REVIEW BY ENGINEER.
 - SAW CUT EDGES 3" MINIMUM BEYOND LIMITS OF UNSOUND CONCRETE AREAS TO 1/2" MAXIMUM DEPTH. TAKE EXTREME CARE TO AVOID CUTTING REINFORCING SQUARE-CUT CORNERS IN PATTERNS AS SIMPLE AS POSSIBLE.
 - 1" MINIMUM CLEARANCE BETWEEN EXPOSED REINFORCING AND SOUND CONCRETE.
 - FORM PATCH AREA AND PUMP WITH SIKADUR 42, GROUT-PAK PER MANUFACTURER'S SPECIFICATIONS.
 - EXTEND PATCH AREA TO 3" BEYOND UNCORRODED REINFORCING. PROVIDE SUPPLEMENTAL REINFORCING AT REINFORCING THAT HAS LOST MORE THAN 10% OF ITS CROSS-SECTION. BARS MAY BE LAPPED WITH MINIMUM ACI CLASS "B" TENSION LAP OR MECHANICAL SPLICES MAY BE PROVIDED. COAT ALL EXPOSED CONCRETE AND REINFORCING WITH BONDING / REINFORCEMENT PROTECTION, SIKA ARMATEC 110 PER MANUFACTURER'S SPECIFICATIONS. PATCH SHALL BE FULL DEPTH OF PANEL AT PANEL BEARING.
 - PROVIDE GALVANIZED ANODES AT EACH AND AT 12" OC OF ALL REINFORCING EXPOSED DURING DEMOLITION. DO NOT COAT OF REBAR WITH SIKA ARMATEC 110 WHERE WIRE LEADS CONNECT TO REINFORCING.

DEMOLITION

- PERFORM SOUNDING OF CONCRETE SURFACES AS REQUIRED TO IDENTIFY SPALLING CONCRETE. MARK ALL SPALLED AREAS WITH A PAINT OUTLINE.
- DEMOLISH CONCRETE TO AT LEAST THE LIMITS MARKED PER NOTE #1 ABOVE IN ACCORDANCE WITH THE SECTIONS AND TYPICAL DETAILS AND TO A MINIMUM DEPTH OF 1 1/2" OR TO SOUND CONCRETE WHICHEVER IS GREATER. FINAL DEMOLISHED AREA SHALL BE APPROXIMATELY RECTANGULAR WITH STRAIGHT SIDES, LEVEL SURFACE AND SQUARE CUT CORNERS. THIS MAY NECESSITATE REMOVAL OF SOUND CONCRETE SHALL BE DETERMINED AND APPROVED IN ACCORDANCE WITH THE REQUIREMENTS OF THE PROJECT SPECIFICATIONS.
- AT THE PERIMETER OF THE DEMOLITION, THE SURFACE NORMAL TO THE FACE OF MEMBERS SHALL BE SAW-CUT APPROXIMATELY STRAIGHT FOR A MINIMUM DEPTH OF 1/2" OR TO THE DEPTH OF THE EXISTING REINFORCING STEEL WHICHEVER IS LESS. THE FINAL DEMOLISHED SURFACE AT ANY LOCATION SHALL BE REASONABLY SMOOTH WITH NO SHARP PROJECTIONS.
- DO NOT DAMAGE OR CUT EXISTING REINFORCING STEEL DURING DEMOLITION.
- SAND BLAST OR WATER BLAST CLEAN ALL DEMOLISHED SURFACES AND REINFORCING. REMOVE ALL LOOSE MATERIALS AND RUST AND DISPOSE ALL DEBRIS OFF SITE.

SPALL REPAIR

- ALL REINFORCED CONCRETE WORK SHALL BE IN CONFORMANCE WITH THE "BUILDING CODE REQUIREMENTS OF REINFORCED CONCRETE" (ACI 318, LATEST EDITION) AND SPECIFICATION OF STRUCTURAL CONCRETE (ACI 301, LATEST EDITION) OF THE AMERICAN CONCRETE INSTITUTE.
- DEMOLISHED CONCRETE AREA SHALL BE REPAIRED BY THE FORM AND CAST METHOD FOR VERTICAL REPAIRS AND THE CAST-IN-PLACE METHOD FOR HORIZONTAL REPAIRS. DEPTH OF DEMOLISHED AREAS SHALL BE MAINTAINED AT A MINIMUM OF 1 1/2".
- REINFORCEMENT
A. DEFORMED BARS
ASTM A615 GRADE 60
- ALL REINFORCEMENT SHALL BE SECURELY HELD IN PLACE WHILE PLACING CONCRETE. IF REQUIRED, ADDITIONAL BARS, STIRRUPS OR CHAIRS SHALL BE PROVIDED THE THE CONTRACTOR TO FURNISH SUPPORT FOR ALL BARS.

PAINTING

- PAINT ALL EXPOSED CONCRETE IN AREAS THAT HAVE BEEN PREVIOUSLY PAINTED TO MATCH EXISTING PAINT TYPE AND COLOR. COORDINATE WITH THE OWNER.

This document has been electronically signed and sealed by Jude T. Kostage, PE on 09/30/20 using a Digital Signature. Printed copies of this document are not considered signed and sealed and the signatures must be verified on any electronic copies.

HISTORIC MALLORY
SQUARE CABLE HUTS
KEY WEST, FLORIDA

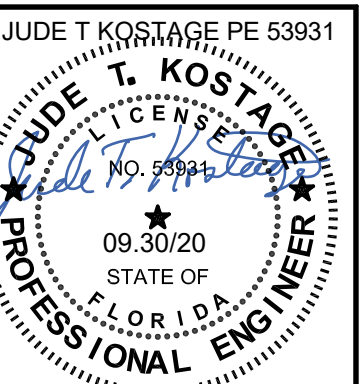

410 Angela Street
Key West, Florida 33040
Telephone (305) 296-1347
Facsimile (305) 296-2727
Florida License AAC002022

Bender & Associates
ARCHITECTS
P.A.

Project No. 1729A

TYPICAL DETAILS

Date: 09/28/2020

S5.1

OF



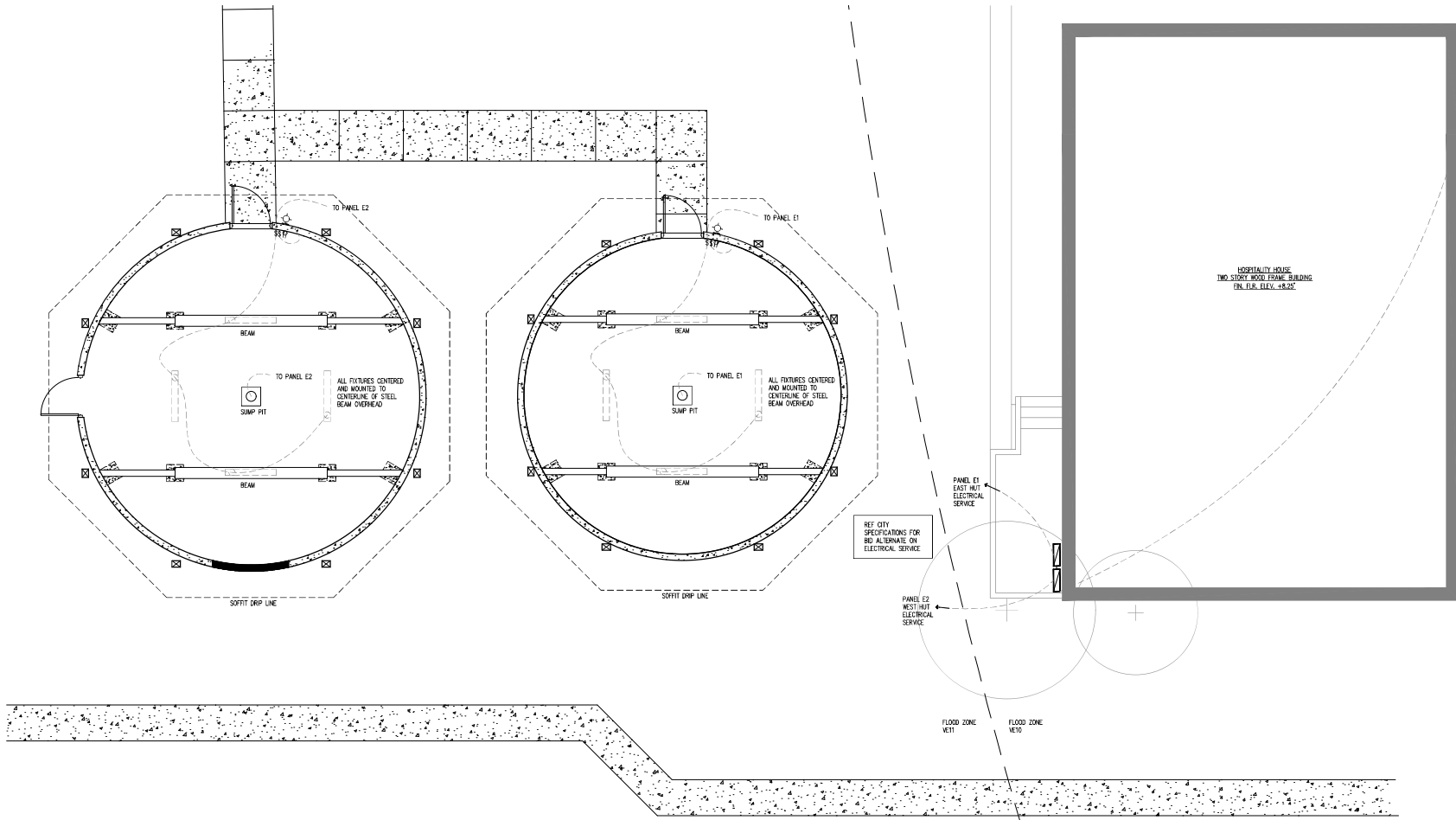

- ELECTRICAL NOTES**
1. All electrical work shall be performed in accordance with the National Electrical Code, Florida Building Code and/or any local codes and ordinances.
 2. The Electrical Contractor shall refer to the Architectural plans for exact location of all equipment. Contractor shall not scale plans.
 3. It is not the intent of these plans to show every and all details of construction. The Electrical Contractor shall furnish and install all items as to provide a complete electrical installation with all equipment in proper working order.
 4. The Electrical Contractor shall be responsible for the full coordination of his work with that of the General Contractor.
 5. It shall be understood that all work performed shall be done so by a licensed Electrical Contractor and in a first class workmanlike manner.
 6. All electrical work and material shall be guaranteed for a period of one year of date of issue of Certificate of Occupancy.
 7. All power and control wiring shall be done by the Electrical Contractor.
 8. All panels shall have typewritten directories indicating all circuits.
 9. Lighting fixtures including lamps shall be provided and installed by the Electrical Contractor.
 10. All wires and cables shall be copper except as indicated. Wires shall be #12 minimum size (control wiring shall be #14AWG). Wire sizes #10 and smaller shall be THW solid. Wire sized #8 and larger shall be THW stranded.
 11. Contractor shall provide temporary power for all trades.
 12. Contractor shall install lighting fixtures provided by others.
 13. All copper water pipe shall be electrical bonded and grounded.
 14. Balance loads in accordance with good construction practices.
 15. The Electrical Contractor shall be responsible for verifying adequate circuitry and breaker sizes which are required by this Contract.
 16. The Contractor shall furnish and install approved hard-wired smoke detectors in accordance with the requirements of the building department having jurisdiction over this project.

1
E1.0 CABLE HUT PROPOSED ELECTRICAL PLAN
SCALE: 1/4" = 1'

HISTORIC MALLORY
SQUARE CABLE HUTS
KEY WEST, FLORIDA



410 Angela Street
Key West, Florida 33540
Telephone (305) 236-1347
Facsimile (305) 236-2727
Florida License ALC002022

Bender & Associates
ARCHITECTS
P.C.

Project No. 1728A
ELECTRICAL PLAN AND
DETAILS
Date: 09/28/2020

E1.0
17 OF 17

PART 6

SPECIFICATIONS

SECTION 02070
SELECTIVE DEMOLITION

PART 1 - GENERAL

1.1 DESCRIPTION

- A. Work included: Carefully demolish and remove from the site those items scheduled to be so demolished and removed. Protect and preserve in place, all historic and/or archaeological materials.
- B. Related work:
 - 1. The Work of this Section must comply with all other Sections of these Technical Special Provisions.
- C. Preservation requirements:
 - 1. The work of this contract involves a significant historic site. Care shall be taken during all selective demolition activities to protect and preserve historic and/or archaeological resources.

1.2 QUALITY ASSURANCE

- A. Use adequate numbers of skilled workmen who are thoroughly trained and experienced in the necessary crafts and who are completely familiar with the specified requirements and the methods needed for proper performance of the work of this Section.

Do not perform any operations that will disturb subsoils, except in the presence of a qualified archaeologist. The Owner will employ a qualified archaeologist to monitor construction activities.

The Architect/Engineer reserve the right to have individual workmen, or subcontractors, removed from the work when in the Architect/Engineer's opinion, those parties are determined to be damaging historic materials or are not sensitive to the nature of the work.

PART 2 - PRODUCTS

(No products are required in this Section)

PART 3 - EXECUTION

3.1 SURFACE CONDITIONS

- A. Examine the areas and conditions under which work of this Section will be performed.

Correct conditions detrimental to timely and proper completion of the Work. Do not proceed until unsatisfactory conditions are corrected.

3.2 DEMOLITION

- A. By careful study of the Contract Documents, determine the location and extent of selective demolition to be performed.
- B. In company with the Architect/Engineer, visit the site and verify the extent and location of selective demolition required.
 - 1. Carefully identify limits of selective demolition.
 - 2. Mark interface surfaces as required to enable workmen also to identify items to be removed and items to be left in place intact.Identify historic elements to be protected.
- C. Prepare and follow an organized plan for demolition and removal of items.
 - 1. Shut off, cap, and otherwise protect existing public utility lines in accordance with the requirements of the public agency or utility having jurisdiction.
 - 2. Completely remove items scheduled to be so demolished and removed, leaving surfaces clean, solid, and ready to receive new materials specified elsewhere.
 - 3. In all activities, comply with pertinent regulations of governmental agencies having jurisdiction.Identify protective measures for historic fabric.
- D. The site is significant historically and archaeologically. The Architect/Engineer may identify areas where work may proceed without an archaeologist. However, if potential artifacts are uncovered, stop all work activities until an inspection by the Owner's archaeologist is conducted. Except for Owner requested material and artifacts, demolished material shall be considered to be property of the Contractor and shall be completely removed from the job site.
- E. Use means necessary to prevent dust becoming a nuisance to the public, to neighbors, and to other work being performed on or near the site.
- F. Use protective measures as necessary to protect all historic materials to remain, and/or archaeological materials.

3.3 REPLACEMENTS

- A. In the event of demolition of items not so scheduled to be demolished, promptly replace such items to the approval of the Architect/Engineer and at no additional cost to the Owner.

END OF SECTION

SECTION 03300
CAST-IN-PLACE CONCRETE

PART 1 - GENERAL

1.1 DESCRIPTION

- A. Work included: Provide cast-in-place concrete, including formwork and reinforcement, where shown on the Drawings, as specified herein, and as needed for a complete and proper installation.
- B. Related Work:
 - 1. Documents affecting work of this Section include, but are not necessarily limited to, General Condition, Supplementary Conditions, and Sections in Part 4 – Summary of the Work, of these Specifications.

1.2 QUALITY ASSURANCE

- A. Use adequate numbers of skilled workmen who are thoroughly trained and experienced in the necessary crafts and who are completely familiar with the specified requirements and the methods needed for the proper performance of the work in this Section.
- B. Comply with the "Specification for Structural Concrete Buildings", ACI 301, except as may be modified herein.
- C. Comply with Field Reference Manual, ACI Publication, SP-15 (88).
- D. The Mallory Square Cable Huts is a significant historic site. Replacement concrete must match adjacent historic concrete finish and appearance.

1.4 PRODUCT HANDLING

- A. Comply with product manufacturers printed instructions.

PART 2 - PRODUCTS

2.1 FORMS

- A. Design, erect, support, brace, and maintain formwork so it will safely support vertical and lateral loads which might be applied until such loads can be supported safely by the concrete structure.
- B. Construct forms to the exact sizes, shapes, lines and dimensions shown, and as required to obtain accurate alignment, location, grades, and level and plumb work in the finished structure.
- C. The majority of existing historic concrete was board formed. Construct all formwork with boards of the same size and configuration as the historic concrete.

2.2 MOISTURE BARRIER

- A. Under all interior building slabs on grade and where so indicated on the Drawings, provide a moisture barrier consisting of:
 - 1. Four inches of clean dry sand, evenly spread as a cushion;
 - 2. "Visqueen" or equal 6 mil thick plastic sheeting, with all joints taped and sealed;
 - 3. Two inches of clean dry sand, evenly spread on top of the installed plastic sheeting.

2.3 REINFORCEMENT

- A. Comply with the following as minimums:
 - 1. Bars: ASTM A615, grade 60 unless otherwise shown on the Drawings, using deformed bars for number 3 and larger.
 - 2. Welded wire fabric: ASTM A185
 - 3. Bending: ACI 318
- B. Fabricate reinforcement to the required shapes and dimensions, within fabrication tolerances stated in the CRSI "Manual of Standard Practices".
- C. Do not use reinforcement having any of the following defects:
 - 1. Bar lengths, depths, or bends exceeding the specified fabricating tolerances;
 - 2. Bends or kinks not indicated on the Drawings or required for the Work;
 - 3. Bars with cross-section reduced due to excessive rust or other causes.

2.4 CONCRETE

- A. Comply with the following minimums:
 - 1. Portland cement: ASTM C150, type I or II, low alkali.
 - 2. Aggregate general:
 - a. ASTM C30, uniformly graded and clean;
 - b. Do not use aggregate known to cause excessive shrinkage.
 - 3. Aggregate, coarse: Crushed rock or washed gravel equal to 3/4" and with a maximum size number 4.
 - 4. Aggregate, fine: Natural washed sand of hard and durable particles varying from fine to particles passing a 3/8" screen, of which at least 12% shall pass a 50-mesh screen.
 - 5. Water: clean and potable
 - 6. Non-set accelerating corrosion inhibiting admixture: commercially formulated, non-set accelerating, anodic inhibitor or mixed cathodic and anodic inhibitor capable of forming a protective barrier and minimizing chloride reactions with steel reinforcement in concrete complying with ASTM C1582. DCI S, Grace Concrete Products.
 - 7. Other ingredients as determined by tests of existing concrete.

- B. Provide concrete with the compressive strengths shown on the Drawings. When such strengths are not shown on the Drawings, provide the following as minimums:
1. Tremie Concrete: 5000 psi
 2. Concrete walls and piers: 4000 psi
 3. Concrete walks and slabs on grade: 3000 psi
 4. Structural concrete slabs: 5000 psi
 5. Minimum cement required per C.Y. and maximum cement ratio:
3000 psi - 430 pounds (W/C-0.60)
4000 psi - 480 pounds (W/C-0.56)
5000 psi - 564 pounds (W.C-0.45)
- C. Surface treatment:
1. Where "sealer", "liquid curing agent" or "hardener" is called for on the drawings, or otherwise used, submit product data to the Architect/Engineer for approval.

2.5 OTHER MATERIALS

- A. Provide other materials, not specifically described but required for a complete and proper installation, as selected by the Contractor subject to the approval of the Architect/Engineer.

PART 3 - EXECUTION

3.1 SURFACE CONDITIONS

- A. Examine the areas and conditions under which work of this Section will be performed. Correct conditions detrimental to timely and proper completion of the Work. Do not proceed until unsatisfactory conditions are corrected.

3.2 REINFORCING

- A. Comply with the following, as well as the specified standards, for details and methods of reinforcing placement and supports.
1. Clean reinforcement and remove loose dust and mill scale, earth, and other materials which reduce bond or destroy bond with concrete.
 2. Position, support, and secure reinforcement against displacement by forms, construction, and the concrete placement operations.
 3. Place reinforcement to obtain the required coverages for concrete protection.
 4. Install welded wire fabric in as long lengths as practicable, lapping adjoining pieces one full mesh minimum.
 5. Unless otherwise shown on the Drawings, or required by governmental agencies having jurisdiction, lap bars 40 diameters minimum.

3.3 EMBEDDED ITEMS

- A. Do not embed piping, other than electrical conduit, in structural concrete.
 - 1. Locate conduit to maintain maximum strength of the structure.
 - 2. Increase the thickness of the concrete if the outside diameter of the conduit exceeds 30% of the thickness of the concrete.
- B. Set bolts, inserts, and other required item in the concrete, accurately secured so they will not be displaced, and in the precise locations needed.

3.4 MIXING CONCRETE

- A. Transit mix the concrete in accordance with provisions of ASTM C94.
- B. Mixing water:
 - 1. At the batch plant, withhold 2-1/2 gal of water per cu yd. of concrete.
 - 2. Upon arrival at the job site, add all or part of the withheld water (as required for proper slump) before the concrete is discharged from the mixer.
 - 3. Mix not less than five minutes after the withheld water has been added, and not less than one minute of that time immediately prior to discharge of the batch.
 - 4. Unless otherwise directed, provide 15 minutes total mixing time per batch after first addition of water.
- C. Do not use concrete that has stood for over 30 minutes after leaving the mixer, or concrete that is not placed within 60 minutes after water is first introduced into the mix.

3.5 PLACING CONCRETE

- A. Preparation:
 - 1. Remove foreign matter accumulated in the forms.
 - 2. Rigidly close openings left in the formwork.
 - 3. Wet wood forms sufficiently to tighten up cracks. Wet other material sufficiently to maintain workability of the concrete.
 - 4. Use only clean tools.
- B. Conveying:
 - 1. Perform concrete placing at such a rate that concrete which is being integrated with fresh concrete is still plastic.
 - 2. Deposit concrete as nearly as practicable in its final location so as to avoid separation due to re-handling and flowing.
 - 3. Do not use concrete which becomes non-plastic and unworkable or does not meet required quality control limits, or has been contaminated by foreign materials.
 - 4. Remove rejected concrete from the job site.

- C. Placing concrete in forms:
 - 1. Deposit concrete in horizontal layers not deeper than 24", and avoid inclined construction joints.
 - 2. Remove temporary spreaders in forms when concrete has reached the elevation of the spreaders.

- D. Placing concrete slabs:
 - 1. Deposit and consolidate concrete slabs in a continuous operation, within limits of construction joints, until the placing of a panel or a section is completed.
 - 2. Bring slab surfaces to the correct level with a straightedge, and then strike off.
 - 3. Use bullfloats or darbies to smooth the surface, leaving the surface free from bumps and hollows.
 - 4. Do not sprinkle water on the plastic surface. Do not disturb the slab surface prior to start of finishing operations.

3.6 CONSOLIDATION

- A. General
 - 1. Consolidate each layer of concrete immediately after placing, by use of internal concrete vibrators supplemented by hand spading, rodding, or tamping.
 - 2. Do not vibrate forms or reinforcement.
 - 3. Do not use vibrators to transport concrete inside the forms.

3.7 JOINTS

- A. Construction joints:
 - 1. Do not use horizontal construction joints except as may be shown on the Drawings.
 - 2. If additional construction joints are found to be required, secure the Architect/Engineer's approval of joint design and location prior to start of concrete placement.

- B. Expansion joints:
 - 1. Do not permit reinforcement or other embedded metal items that are being bonded with concrete (except dowels in floors bonded on only one side of the joints) to extend continuously through any expansion joint material approved by the Architect/Engineer.
 - 2. Fill expansion joints full depth with expansion joint material approved by the Architect/Engineer.

3.8 CONCRETE FINISHING

- A. Except as may be shown otherwise on the Drawings, provide the following finishes at the indicated locations:

1. Scratch finish:
 - a. Apply to monolithic slab surfaces that are to receive concrete floor topping or mortar setting bed.
2. Float finish:
 - a. Apply to monolithic slab surface that are to receive trowel finish and other finishes specified hereinafter, and to slab surfaces which are to be covered with insulation.
3. Trowel finish:
 - a. Apply to monolithic slab surfaces that are to be exposed to view, unless otherwise shown, and to slab surfaces that are to be covered with resilient flooring, carpeting, paint, or other thin-film finish coating system.
4. Non-slip broom finish
 - a. Apply to walks, stairs, drives, ramps, and similar pedestrian and vehicular areas.

3.9 REMEDIAL WORK

- A. Repair or replace deficient work as directed by the Architect/Engineer and at no additional cost to the Owner.

3.10 FIELD QUALITY CONTROL

- A. Testing Agency: Engage a qualified independent testing and inspecting agency to sample materials, perform tests, and submit test reports during concrete placement according to requirements specified in the Article.
- B. Testing Services: Testing of composite samples of fresh concrete obtained according to ASTM C 172 shall be performed according to the following requirements:
 1. Testing Frequency: Obtain one composite sample for each day's pour of each concrete mix exceeding 5 cu. yd., but less than 25 cu. yd., plus one set for each additional 50 cu. yd. or fraction thereof.
 2. Slump: ASTM C 143; one test at point of placement for each composite sample, but not less than one test for each day's pour of each concrete mix. Perform additional tests when concrete consistency appears to change.
 3. Air Content: ASTM C 231, pressure method, for normal-weight concrete; ASTM C 173, volumetric method, for structural lightweight concrete; one test for each composite sample, but not less than one test for each day's pour of each concrete mix.
 4. Concrete Temperature: ASTM C 1064; one test hourly when air temperature is 40 deg. F and below and when 80 deg F and above, and one test for each composite sample.
 5. Compression Test Specimens: ASTM C 31/C 31M; cast and laboratory cure one set of four standard cylinder specimens for each composite sample.

- a. Cast and field cure one set of four standard cylinder specimens for each composite sample.
6. Compressive-Strength Tests: ASTM C 39; test two laboratory-cured specimens at 7 days and two at 28 days.
 - a. Test two field-cured specimens at 7 days and two at 28 days.
 - b. A compressive-strength test shall be the average compressive strength from two specimens obtained from same composite sample and tested at age indicated.
- C. When strength of field-cured cylinders is less than 85 percent of companion laboratory-cured cylinders, Contractor shall evaluate operations and provide corrective procedures for protecting and curing in-place concrete.
- D. Strength of each concrete mix will be satisfactory if every average of any three consecutive compressive-strength tests equals or exceeds specified compressive-strength and no compressive-strength test value falls below specified compressive strength by more than 500 psi.
- E. Test results shall be reported in writing to Owner, Architect/Engineer, concrete manufacturer, and Contractor within 48 hours of testing. Reports of compressive-strength tests shall contain Project identification name and number, date of concrete placement, name of concrete testing and inspecting agency, location of concrete batch in Work, design compressive strength at 28 days, concrete mix proportions and materials, compressive breaking strength, and type of break for both 7-and 28-day tests.
- F. Nondestructive Testing: Impact hammer, so no scope, or other nondestructive device may be permitted by Architect/Engineer but will not be used as sole basis for approval or rejection of concrete.
- G. Additional Tests: Testing and inspecting agency shall make additional tests of concrete when test results indicate that slump, air entrainment, compressive strengths, or other requirements have not been met, as directed by Architect/Engineer. Testing and inspecting agency may conduct tests to determine adequacy of concrete by cored cylinders complying with ASTM C 42 or by other methods as directed by Architect/Engineer.

END OF SECTION

SECTION 03310
CONCRETE REPAIRS

PART 1 - GENERAL

1.1 DESCRIPTION

- A. Work included: Provide cast-in-place concrete repairs, including formwork and reinforcement, where shown on the Drawings, as specified herein, and as needed for a complete and proper installation.

1.2 QUALITY ASSURANCE

- A. Use adequate numbers of skilled workmen who are thoroughly trained and experienced in the necessary crafts and who are completely familiar with the specified requirements and the methods needed for the proper performance of the work in this Section.
- B. Comply with the "Specification for Structural Concrete Buildings", ACI 301, except as may be modified herein.
- C. Do not commence placement of concrete until mix designs have been reviewed and approved by the Architect/Engineer and all governmental agencies having jurisdiction.
- D. The Mallory Square Cable Huts is a significant historic site. All repairs must match adjacent historic fabric.

1.3 SUBMITTALS

- A. Submit concrete mix designs to the Architect/Engineer for review and approval.

1.4 PRODUCT HANDLING

- A. Comply with product manufacturers printed instructions.

PART 2 - PRODUCTS

2.1 FORMS

- A. Design, erect, support, brace and maintain formwork so it will safely support vertical and lateral loads which might be applied until such loads can be supported safely by the concrete structure.
- B. Construct forms to the exact sizes, shapes, lines and dimensions shown, and as required to obtain accurate alignment, location, grades, and level and plumb work in the finished structure. Match existing adjacent historic board formed joints, sizes and patterns.

2.2 REINFORCEMENT

- A. Comply with the following as minimums:
 - 1. Bars: ASTM A615, grade 60 unless otherwise shown on the Drawings, using deformed bars for number 3 and larger.
 - 2. Welded wire fabric: ASTM A185
 - 3. Bending: ACI 318
- B. Fabricate reinforcement to the required shapes and dimensions, within fabrication tolerances stated in the CRSI "Manual of Standard Practices".
- C. Do not use reinforcement having any of the following defects:
 - 1. Bar lengths, depths, or bends exceeding the specified fabricating tolerances;
 - 2. Bends or kinks not indicated on the Drawings or required for the Work;
 - 3. Bars with cross-section reduced due to excessive rust or other causes.

2.3 CONCRETE

- A. Comply with the following minimums:
 - 1. Portland cement: ASTM C150, type I or II, low alkali.
 - 2. Aggregate general:
 - a. ASTM C33, uniformly graded and clean;
 - b. Do not use aggregate known to cause excessive shrinkage.
 - 3. Aggregate, coarse: Crushed rock or washed gravel equal to 3/4" and with a maximum size number 4.
 - 4. Aggregate, fine: Natural washed sand of hard and durable particles varying from fine to particles passing a 3/8" screen, of which at least 12% shall pass a 50-mesh screen.
 - 5. Water: clean and potable
- B. Surface treatment:
 - 1. Where "sealer", "liquid curing agent" or "hardener" is called for on the drawings, or otherwise used, submit product data to the Architect/Engineer for approval.

2.4 ACAPS@ CONCRETE REPAIRS FOR SPALLED OR DETERIORATED CONCRETE

- A. Repair Mortars
 - 1. For formed horizontal and vertical repairs:
 - a. SikaTop III Plus, extended with aggregate per Manufacturer
 - 2. For form & pour and form & pump vertical, overhead, and horizontal surfaces full depth structural repair:
 - a. MAPEI Planitop 11 SCC (pre-extended) – up to 8"

- b. MAPEI Planitop 15 extended with aggregate per Manufacturer.
 3. For hand-packed vertical and overhead repairs:
 - a. SikaTope 123
 - b. MAPEI Planitop 23
 - c. MAPEI Planitop XS.
 - d. MasterEmaco N 425

B. Epoxy Adhesives

1. For sealing cracks to be injected:
 - a. Sidadur 31 Hi-Mod Gel Epoxy
 - b. MAPEI Planibond AE Fast
2. For injecting cracks in structure:
 - a. Sikadur 35 Hi-Mod LV Epoxy,
 - b. Simpson ETI 2 component injection epoxy,
 - c. MAPEI Epojet,
 - d. MAPEI Epojet LV.
3. For filling cracks in slabs on grade:
 - a. Sikadur 35 Hi-Mod LV Epoxy
 - b. MAPEI Planibond CR 50
 - c. MAPEI Epojet LV.

C. Anti-Corrosion Protective Coating for Reinforcement:

1. SikaTop 108 Armatec
2. MAPEI Mapefer 1K
3. SikaTop Armatec 110
4. MAPEI Planibond 3C
5. MasterEmaco P 124

D. Concrete Bonding Agent:

1. Sikadur 32 Hi-Mod or LPL
2. MAPEI Planibond EBA
3. SikaTop108, Armatec
4. Sika Armatec 110
5. MAPEI Planibond 3C

E. Penetrating Sealer:

1. Sikagard 705 L, penetrating sealer
2. MAPEI Planiseal WR
3. Sikagard 740 W, penetrating sealer

F. Plaster

1. For base:
 - a. Thoroseal Cement Base plus Acryl 60
 - b. Planiseal 88 plus Planicrete AC
2. For finish:
 - a. Thoroseal Plaster Mix plus Acryl 60

G. Reinforcing Steel

1. ASTM A615, Grade 60

H. Aggregate

1. Coarse: Pea gravel, 1/4" to 3/8" washed, round quartz conforming to ASTM C33.

SECTION 04210
HISTORIC MASONRY
(Including new brick masonry)

PART 1 - GENERAL

1.1 DESCRIPTION

- A. Work included: Provide brick masonry and granite where shown on the Drawings, as specified herein, and as needed for a complete and proper installation.
- B. Related work:
 - 1. The Work of this Section must comply with all other Sections of these Specifications.
 - 2. Section 04500, Masonry Restoration and Cleaning of these Specifications.

1.2 QUALITY ASSURANCE

- A. The work of this project involves a significant historic site. The Waterworks Building dates from 1898 with significant additions through 1926. All work activities must be undertaken with sufficient care to protect this historic resource and must be supervised by personnel who are familiar with the Secretary of Interior's Standards for Rehabilitation.
- B. Use adequate numbers of skilled workmen who are thoroughly trained and experienced in the necessary crafts and who are completely familiar with the specified requirements and the methods needed for proper performance of the work of this Section. Brick masons and craftsmen who install brick, granite and mortar, including repointing, will be required to provide evidence of qualifications. Comply with submittal requirements in 1.3, Submittals, of this Section.
- C. All activities which have the potential to disturb subsoils or otherwise disturb archaeological resources, shall be monitored by the Owner's archaeologist. Notify the Owner at least 72 hours in advance of such activities.
- D. Provide testing services as specified in Section 04211 of these Specifications.
- E. Design basis for mortar: Traditional mortar was made from lime putty, or slaked lime, combined with local sand, generally in a ratio of 1 part lime putty to 3 parts

sand by volume. Often other ingredients, such as crushed marine shells (another source of lime), brick dust, clay, natural cements, pigments, and even animal hair were also added to mortar, but the basic formulation for lime putty and sand mortar remained unchanged for centuries until the advent of Portland cement or its forerunner, Roman cement, a natural hydraulic cement. Portland cement was first manufactured in the United States in 1872, although it was imported before this date. But it was not in common use throughout the country until the early 20th century. Prior to that time in the United States, natural cements were used in addition to lime putty. Up until the turn of the century Portland cement was considered primarily an additive, or “minor ingredient” to help accelerate mortar set time. By the 1930’s, however, most masons used a mix of equal parts Portland cement and lime putty. Thus, the mortar found in masonry structures built between 1873 and 1930 can range from pure lime and sand mixes to a wide variety of lime, Portland or natural cement, and sand combinations. Mortar may vary throughout the fort and multiple tests will be required. Multiple sources may be needed for sand to match historic mortars.

1.3 SUBMITTALS

- A. Comply with pertinent provisions of Division 1, General Conditions.
- B. Submit qualifications, resumes and experience on similar projects, along with project profiles. Documentation shall include, but not be limited to:
 - 1. Resumes of academic training and employment in the applicable field;
 - 2. Evidence of possession of required licenses and/or business permits; and
 - 3. Evidence of at least three years in the aggregate of on the job experience in historic preservation projects of a similar nature.

In addition to the documentation required above, provide a minimum of 3 references, one of which is an Owner of a completed project of the Subcontractor and one of which is an Architect or Engineer for a completed project. Provide any additional information, including photographs, as applicable, in order to show historic preservation experience.

For individual craftsmen, 3 references from past employers will be required. The Architect, under this provision, may waive other requirements of this Specification Section.

- C. Product data:
 - 1. Materials list of items proposed to be provided under this Section;

2. Manufacturer's specifications and other data and samples needed to prove compliance with the specified requirements.
- D. Mock-ups:
1. At an area on the site where approved by the Architect, provide mock-up masonry panels.
 - a. Provide one mock-up panel for each combination of brick, bond pattern, mortar color, and joint type used in the Work.
 - b. The mock-up panels may be part of the Work, and may be incorporated into the finished Work when so approved in advance by the Architect.
 - c. Revise as necessary to secure the Architect's approval.
- E. Schedule of Repairs

1.4 PRODUCT HANDLING

- A. Comply with pertinent provisions of Division 1, General Conditions.
- B. Products and methods listed in these specifications are subject to use at specific locations. The intent is to ensure the use of compatible materials, i.e. exactly matching historic fabric with existing historic materials, or by fabricating new materials that match historic materials as closely as possible. Use historic materials first and move to compatible new materials as existing stock is depleted.**

PART 2 - PRODUCTS

2.1 BRICK, GRANITE AND MISCELLANEOUS STONEMWORK

- A. Acceptable manufacturers and products:
1. Used brick of similar size, color, consistency and strength as existing (obtained from off-site source), historic brick to be removed from the building for re-use. Sections of the existing brick wall will require partial removal of brick to facilitate stabilization of the wall. Clean old mortar from removed masonry and reinstall the components in the work.
 2. New brick of equal characteristics to existing when sufficient historic brick is not available. Provide compression tests of at least three (3)

bricks to verify strength requirements. Provide samples of the proposed brick.

3. Other stone elements, such as granite or slate, to match existing.

2.2 OTHER MATERIALS

A. Aggregate:

1. Sand for mortar: Fine, sharp, natural sand. Comply with ASTM C144. Samples of each type will be required for laboratory comparison to historic sand.

B. Lime:

1. Hydrated lime: Comply with ASTM C207, type "S."
2. Lime Putty: Comply with ASTM C5.

C. Natural Cement: Comply with ASTM C10/10M.

D. Water: Provide potable water free from injurious amounts of acids, alkalis, oil, and organic matter.

E. Coloring pigment: Provide pure, ground mineral oxides, non-fading and alkali proof. Coloring pigments will only be used if mortar mixes do not match historic mortars.

2.3 GRANITE AND STONE REPAIRS

A. None.

2.4 MORTAR AND GROUT MIXES

A. Mortar for repointing or setting historic masonry: (Mortar must comply with ASTM C270)

1. The mortar mix is based on historic documents and research, and is subject to modification based on new test results of existing mortar. The historic mortar likely contained natural cement in the mix.

Rosendale Natural Cement is available from:

Rosendale Natural Cement Products

3 Northwest Drive
Plainville, CT 06062
860-747-2220 or 800-341-6621 Fax. 860-747-2280

Provide mortar consisting of:

- a. One part natural cement
- b. Two parts lime putty; to
- c. Nine parts fine, sharp, natural sand measured damp and loose.
- d. High quality mortar color for tinting of mortar to match existing, when so directed by the Architect. Historic mortars obtain their color from the sand and colors will vary depending on the source. Mortar color will only be used if color compatible sand sources cannot be found.

2. **Aggregates**

Aggregates make up the largest component of mortar. While sand is now used almost exclusively, other products also served as aggregates in old buildings.

- a. Sand gives mortar most of its characteristic color and texture. Historic sand colors may range from white to gray to yellow within a single sample. Also, because sand often was not screened and graded as it is today, the size of grains may vary from fine to coarse. Therefore, in order to match the range of colors and grain sizes in the original sample, it may be necessary to obtain sand from several sources and then combine it. Even in a simple, small job, some coarse-grade sand may have to be added to standard packaged sand, unless joints are so fine that the look of the mortar does not play an important visual role.

Natural beach or river sand has rounded edges, as seen under a magnifying glass or low-power microscope. Natural sand provides a better visual match with old mortar and can produce good plasticity with less water, allowing the mortar to be forced into the joint more easily and forming a better contact with the old mortar and the masonry. The sand in repointing mortar must be clean and match the original as closely as possible to provide the proper color without other additives. Conform to ASTM C-144.

- b. Other aggregates in mortar usually make up a very small proportion of the total. These aggregates, however, can be important in achieving a good color and texture match. For

historic buildings, it is especially important to identify them in the original mortar and specify them in the new one, suggesting, if possible, where they may be obtained. Other materials that may be found in old mortars include animal hair, clay articles and partially burned lime. Comply with mortar test results.

4. Measure the ingredients accurately and proportion by volume.
 5. Mix in an approved, mechanically operated mortar mixer for at least three minutes after all ingredients are in the drum, and at least long enough to make a thorough, complete intimate mix of the materials.
 6. Discard mortar which is unused 1 hour following the initial mixing.
 7. Provide a test batch of mortar with one set of test cubes, prior to use of the subject mix in the project.
- B. Admixtures: No admixtures will be allowed.
- C. Testing: Provide the services of an independent testing laboratory on the mix, as well as an on site test panel for mortar, as specified in Section 04211.

PART 3 - EXECUTION

3.1 SURFACE CONDITIONS

- A. Examine the areas and conditions under which work of this Section will be performed. Correct conditions detrimental to timely and proper completion of the Work. Do not proceed until unsatisfactory conditions are corrected and specifically approved by the Architect/Engineer.

3.2 INSTALLATION

- A. Wetting of bricks:
1. When being laid, provide brick suction sufficient to hold the mortar and to absorb water from the mortar and grout.
 2. Provide brick sufficiently damp so that mortar will remain plastic enough to permit the brick to be leveled and plumbed immediately after being laid without destroying the bond.
- B. Laying:
1. Unless otherwise indicated on the Drawings, lay the brick to follow the lines, slopes and contours of the existing work to be matched.

2. Use line blocks whenever possible. When it is absolutely necessary to use a line pin, fill the hole immediately after the pin is withdrawn.
3. Use only bricks that are clean and free from dust and other foreign matter.
4. Lay bond patterns to match the existing adjacent construction unless otherwise shown on the Drawings. Match existing bond for color and pattern at repairs.
5. Bed joints:
 - a. Bevel all bed joints, sloping toward the center of the wall in such a manner that the bed joints will be filled when the brick is finally brought to line.
 - b. Do not furrow the bed joints.
 - c. Match all existing historic bed joints.
6. Where bricks are moved or shifted, remove and lay again in fresh mortar.
7. Immediately remove mortar and grout from areas where they are not scheduled to be placed.

C. General Requirements:

1. Fill mortar into joints in 1/4 inch "lifts". Start by filling deeper sections, compacting each layer, packing it into the rear and corners of the joint.
2. Without delay, apply the next layer at 1/4 inch thickness. A minimum of 2 layers are required.
3. When final layer is thumbprint hard, tool to specified profile. Match to adjacent, existing profile or to original profile as instructed.
4. To avoid changing the appearance of the building, it may be necessary to slightly recess the mortar from the masonry surface. Do not flush fill joints in worn masonry if this results in a visually wider joint than the original.
5. Remove excess mortar and smears using a stiff natural bristle brush and clean water before it has set.
6. Wet cure tooled joints as required by lightly misting with clean water periodically for a minimum of 3 days following installation. Misting should be performed every hour or two on the first day, as required to maintain the mortar in a wet condition, and this may be reduced to every three or four hours on subsequent days.
7. Allow mortar to fully cure for a minimum of 28 days before final cleaning. Longer cure times are required in cooler weather. Only low pressure should be used to avoid damaging newly repointed joints.

3.3 JOINERY

A. General:

1. Cut out and repoint defective joints where necessary to a minimum of one inch (1").
2. On all joints exposed to the weather, tool and make smooth, solid, and watertight. Match existing construction at areas of repair.
3. Use of grinders or other power tools for cutting out of historic mortar joints is strictly prohibited. Preparation of joints in historic masonry shall be accomplished using hand tools only.

a. **The Repointing Process**

The difference between a good and a poor repointing job is not always obvious to the unpracticed eye. Merely brushing away the loose mortar and filling the joint will produce a repointing job that may look good for several months, but within a few years the mortar will pop out of the joints. Good preparation of the joint takes a fair amount of work but is essential to getting a repointing job to last the 50 to 100 years that it should. It is during preparation for repointing that the masonry runs the greatest risk of permanent damage; cleaning out the joint should be done only by experienced workers using hand tools under the close supervision of an experienced mason.

Preparing the Joint: All loose, crumbling, powdery, excessively soft, badly stained or cracked mortar should be raked (cut out) to a uniform minimum depth and the full width of the joint, preferably using hand rather than power tools.

Raking: To ensure an adequate bond, the joint should be raked to a depth equal to between 2 and 2½ times the width of the vertical joint (usually ½ to ¾ inch deep with brick and 1 to 2 inches with wider stone joints.) Proper depth ensures that there will be enough surface contact between the mortar and masonry so that surface adhesion and friction will create a good bond without the use of special bonding agents. Any loose and deteriorated mortar beyond this minimum depth should also be taken out. Mortar should be removed cleanly from the masonry, leaving square corners and a flat surface at the back of the cut.

Before filling joints, any bricks or stones that are loose should be

reset. Any pieces of brick that chipped off while chiseling out the old mortar can be glued back with ceramic glue; stone can be reattached with epoxy. The joints should be finally cleaned out by gently flushing with water to remove all loose particles and dust. At the time of filling, the joints should be damp to prevent the too-rapid absorption of water from the new mortar, but no standing water should be present.

Hand versus Power Tools: The best way to remove old mortar is by hand using a small-headed chisel, no wider than half the width of the joint. Although handwork is more time consuming than using power tools, it presents far less risk of permanently damaging the brick or stone. If mortar can be removed only with power tools, it probably should not be removed in the first place.

For the most part, power tools such as circular saws with carbide blades or pneumatic impact hammers almost always damage the edges of the masonry units and overcut the ends of joints (especially the vertical joints in a brick wall). Damage to the brick or stone not only affects its visual character, but can also lead to accelerated weather damage.

4. Provide samples of each type of joint.
- B. Joint pattern:
1. All joints shall match the existing adjacent historic construction.

3.4 REPAIR OF HISTORIC MASONRY

- A. Schedule of repairs:
1. Inspect all exterior surfaces to determine and verify the extent of historic masonry repair and replacement required.
 2. Prepare a schedule, for each exterior elevation and on a room by room basis, describing the areas requiring repointing, repair, reattachment or replacement. Address each type of historic masonry material, including brick, stone, granite and slate. Review the schedule with the Architect and modify as required, securing the approval of the Architect prior to commencing any work of this Section.
- B. Repair methods:
1. Type A: Repointing only, matching historic mortar and joint profiles

- exactly.
2. Type B: Removal of brick with surface deterioration; cleaning and re-installing with the sound face exposed.
 3. Type C: Installation of new or historic replacement brick where historic brick is missing, broken, or too severely deteriorated for re-use.
 4. Type D: Removal of brick arches, or other structural elements, and reconstruction with the same brick.

3.5 POINTING AND CLEANING

- A. At the completion of this portion of the Work, Architect will visually inspect the work of this Section and require pointing or cutting out, and repointing if necessary, all holes and defective joints at existing, as well as new mortar joints.
- B. Thoroughly clean all masonry surfaces to be left exposed in the finished Work, removing all traces of mortar, grout, and foreign matter.

END OF SECTION

SECTION 04500
MASONRY RESTORATION AND CLEANING
(Includes Defoliation and Efflorescence)

PART 1 - GENERAL

1.1 DESCRIPTION

- A. Work included: Clean and restore the exterior surfaces, as specified herein, and as needed for a complete and proper installation.
- B. Related work:
 - 1. The Work of this Section must comply with all other Sections of these Specifications.
- C. Definitions:
 - 1. "Clean" and/or "restore" as used herein, means removal of paint materials including primers, emulsions, epoxy, enamels, and other applied materials on existing brick and removal of plant growth and efflorescence from brick surfaces.

1.2 QUALITY ASSURANCE

- A. The work of this project involves a significant historic site. The Waterworks Building is a historic site. All work activities must be undertaken with sufficient care to protect this historic resource and must be supervised by personnel who are familiar with the Secretary of Interior's Standards for Rehabilitation.
- B. Use adequate numbers of skilled workmen who are thoroughly trained and experienced in the necessary crafts and who are completely familiar with the specified requirements and the methods needed for proper performance of the work of this Section. Brick masons and craftsmen who install brick, granite and mortar, including repointing, will be required to provide evidence of qualifications. Comply with submittal requirements in 1.3, Submittals, of this Section.
- C. All activities which have the potential to disturb subsoils or otherwise disturb archaeological resources, shall be monitored by the Owner's archaeologist. Notify the Owner at least 72 hours in advance of such activities.

- D. Chemical products coordination:
 - 1. Provide products which are compatible with the surface to be cleaned and subsequent chemicals.
 - 2. Review other Sections of these Specifications as required, assuring compatibility of the total coating system for the various substrata.
 - 3. Furnish information on the characteristics of the specific materials to assure that compatible products and systems are used.
 - 4. Notify the Architect in writing of anticipated problems in using the specified systems.

1.3 SUBMITTALS

- A. Comply with pertinent provisions of Division 1, General Conditions.
- B. Product data:
 - 1. Materials list of items proposed to be provided under this Section;
 - 2. Manufacturer's specifications and other data needed to prove compliance with the specified requirements.
 - 3. Manufacturer's recommended application procedures.
- C. Documentation shall include, but not be limited to:
 - 1. Resumes of academic training and employment in the applicable field;
 - 2. Evidence of possession of required licenses and/or business permits; and
 - 3. Evidence of at least three years in the aggregate of on the job experience in historic preservation projects of a similar nature.

In addition to the documentation required above, provide a minimum of 3 references, one of which is an Owner of a completed project of the Subcontractor and one of which is an Architect or Engineer for a completed project. Provide any additional information, including photographs, as applicable, in order to show historic preservation experience.

For individual craftsmen, 3 references from past employers will be required. The Architect, under this provision, may waive other requirements of this Specification Section.

- D. Provide a schedule of repairs identifying all locations and products proposed to the Architect. Review the schedule on site with the Architect and modify as required.

1.4 PRODUCT HANDLING

- A. Comply with pertinent provisions of Division 1, General Conditions.

PART 2 - PRODUCTS

2.1 MATERIALS

- A. Acceptable materials:

1. Acidic Cleaner: Manufacturer's standard strength acidic masonry restoration cleaner composed of hydrofluoric acid blended with other acids including trace of phosphoric acid (but no hydrochloric acid) and combined with special wetting systems and inhibitors.

- a. Products: Provide one of the following or equal approved by Architect:

"Sure Klean Restoration Cleaner", ProSoCo, Inc.

"Diedrich 101 Masonry Restorer", Diedrich Chemicals

2. Chemical Paint Remover: Manufacturer's standard thixotropic/alkaline formulation for removing paint coatings from masonry.

- a. Products: Provide one of the following or equal approved by Architect:

"DADS – Easy Spray Remover," Sansher Corporation

"Peel Away 1: Heavy Duty Paint Removal System," Dumond Chemicals, Inc.

"Peel Away 7: Architectural & Industrial Paint & coatings Remover," Dumond Chemicals

"Sure Klean Heavy-Duty Paint Stripper"; ProSoCo, Inc.

"Diedrich 505/606/606X Paint Remover"; Diedrich Chemicals.

3. Liquid Strippable Masking Agent: Manufacturer's standard liquid, film forming, strippable masking material for protecting glass metal and

polished stone surfaces from damaging effect of acidic and alkaline masonry cleaners.

- a. Products: Provide one of the following or equal approved by Architect:

"Sure Klean Acid Stop"; ProSoCo, Inc.

"Diedrich Acid Guard"; Diedrich Chemicals.

4. Defoliant: Manufacturer's standard strength vegetation killer containing prometon

- a. Products: Provide one of the following or equal approved by Architect:

"Triox" vegetation killer, Chevron Chemical Company

"Roundup" or approved equal

5. Efflorescence Removal: Manufacturer's standard poultice cleaner containing soda ash, talc and Fullers earth.

- a. Products: Provide:

"Standoff Marble Poultice", ProSoCo, Inc.

or equal approved by Architect.

6. Provide drop cloths, sheets, tape, etc. to protect the structure, people landscaping and surrounding areas.

2.2 APPLICATION EQUIPMENT

- A. For application of the approved products, use only such equipment as is recommended for application by the manufacturer of the particular product and as indicated.
- B. Prior to use of application equipment, verify that the proposed equipment is actually compatible with the material to be applied, and that integrity of the system will not be jeopardized by use of the proposed equipment.
- C. Spray Equipment: Provide equipment for controlled spray application of water and chemical cleaners, if any, at rates indicated for pressure, measured at spray

tip, and for volume.

1. For spray application of chemical cleaners provide low-pressure tank or chemical pump suitable for chemical cleaner indicated, equipped with cone-shaped spray-tip.
2. For spray application of water provide fan-shaped spray-tip which disperses water at angle of not less than 15 degrees.
3. For application by brush or roller, provide all equipment required by the manufacturers printed literature.

2.3 OTHER MATERIALS

- A. Provide other materials, not specifically described but required for a complete and proper installation, as selected by the Contractor subject to the approval of the Architect.

PART 3 - EXECUTION

3.1 SURFACE CONDITIONS

- A. Examine the areas and conditions under which work of this Section will be performed. Correct conditions detrimental to timely and proper completion of the Work. Do not proceed until unsatisfactory conditions are corrected.
- B. Test panels of all chemical systems are required. Minimum size shall be 4' x 8' and in a location as approved by the Architect.
- C. For lead paint removal; use "Peel Away 1: Heavy Duty Paint Removal System," in compliance with the manufacturer's printed instructions and applicable Federal regulations.

3.2 MATERIALS PREPARATION

- A. General:
 1. Mix and prepare materials in strict accordance with the manufacturers'

recommendations for their intended use and as approved by the Architect.

2. When materials are not in use, store in tightly covered containers.
3. Maintain containers used in storage, mixing, and application of paint in a clean condition, free from foreign materials and residue.

3.3 SURFACE PREPARATION

A. General:

1. Perform preparation and cleaning procedures in strict accordance with the manufacturer's recommendations and as approved by the Architect.
2. Remove removable items which are in place and are not scheduled to receive cleaning or provide surface applied protection prior to surface preparation and chemical restoration operations.
3. Following completion of restoration in each space or area, reinstall the removed items by using workmen who are skilled in the necessary trades.
4. Schedule the cleaning and protect surrounding areas so that contaminants from the cleaning process will not damage surrounding areas.

3.4 APPLICATION

- A. Safety precautions/personnel: All workmen must be protected by rubber or polyethylene suits, boots, gloves, face shield and protective head gear. Avoid contact with eyes and skin. Comply with OSHA regulations and all other applicable governmental regulations.
- B. Safety precautions/adjacent area: Employ all necessary precautions and coverings to prevent unnecessary damage to the building being restored as well as surrounding buildings, landscaping, electrical and adjacent items, etc. Avoid drift as it may injure passersby or damage vehicles.
- C. Efflorescence: Remove efflorescence using soft bristle brushes wherever possible.
- D. Poultrice application: (When approved by the Architect)
 1. Apply the prepared poultrice mix to the surface using a plaster trowel or airless spray equipment. Uniformly apply a 1/4" thick coating.

2. Using a light polyethylene film or other moisture resistant material, cover the area treated with Stand Off Marble Poultrice. Press poly film against poultrice - it will cling to the surface. Tape or otherwise seal off edges of the poly film.
 3. Allow poultrice (covered with film) to remain on the surface for 12 to 24 hours.
 4. Remove protective film. Scrape off poultrice. Wash the surface thoroughly with fresh water, using a sponge or cloth.
 5. Repeat poultrice procedures where necessary.
- E. Defoliant: Apply with a sprinkling can or pump spray to plant growth on brick and in mortar joints. Reapply after 3 days if needed. Completely remove all dead vegetation from brick surfaces and mortar joints.
- F. Preparatory work:
1. Masonry Restorer - Typical areas of all surfaces that will be contacted during chemical treatment should be thoroughly tested before beginning.
 2. Paint Remover - Provide a test patch to check the action and timing of the remover. (Additional applications may be required on heavy accumulations.)
 3. Efflorescence - Provide a test patch to check the effectiveness of poultrice and compatibility with historic brick and mortar. Hand brush all surfaces with a soft bristle brush prior to application of poultrice. (Additional applications may be required on heavy accumulations.)
 4. Methods/Application: Strictly adhere to the manufacturers printed instructions subject to the approval of the Architect/Engineer.

END OF SECTION

SECTION 06100
ROUGH CARPENTRY

PART 1 - GENERAL

1.1 DESCRIPTION

- A. Work included: Provide wood, nails, bolts, screws, framing anchors, other rough hardware and other items needed, and perform rough carpentry for the construction shown on the Drawings, as specified herein, and as needed for a complete and proper installation.
- B. Related work:
 - 1. Documents affecting work of this Section include, but are not necessarily limited to, General Conditions, Supplementary Conditions, and Sections in Part 4 – Summary of the Work, of these Specifications.

1.2 QUALITY ASSURANCE

- A. Use adequate numbers of skilled workmen who are thoroughly trained and experienced in the necessary crafts and who are completely familiar with the specified requirements and the methods needed for proper performance of the work of this Section.
- B. Codes and standards:
 - 1. In addition to complying with the pertinent codes and regulations of governmental agencies having jurisdiction, unless otherwise specifically directed or permitted by the Architect/Engineer comply with:
 - a. "Product Use Manual" of the Western Wood Products Association for selection and use of products included in that manual;
 - b. "Plywood Specification and Grade Guide" of the American Plywood Association;
 - c. "Standard Specifications for Grades of California Redwood Lumber" of the Redwood Inspection Bureau for Redwood, when used.

1.3 PRODUCT HANDLING

- A. Comply with pertinent provisions of General Condition, Supplementary Conditions, and Sections in Part 4 – Summary of the Work, of these Specifications.
- B. Protection:
 - 1. Deliver the materials to the job site and store, in a safe area, out of the way of traffic, and shored up off the ground surface.
 - 2. Identify framing lumber as to grades, and store each grade separately from other grades.

3. Protect metals with adequate waterproof outer wrapping.
4. Use extreme care in off loading of lumber to prevent damage, splitting, and breaking of materials.

PART 2 - PRODUCTS

2.1 GRADE STAMPS

- A. Identify framing lumber by the grade stamp of the West Coast Lumber Inspection Bureau, or such other grade stamp as is approved in advance by the Architect/Engineer.
- B. Identify plywood as to species, grade, and glue type by the stamp of the American Plywood Association.
- C. Identify other materials of this Section by the appropriate stamp of the agency approved in advance by the Architect/Engineer.

2.2 MATERIALS

- A. Provide materials in the quantities needed for the Work shown on the drawings, and meeting or exceeding the following standards of quality:
 1. Horizontal framing members: Southern Yellow Pine or Douglas Fir-Hemlock, Table 1, No. 1, pressure treated.
 2. Vertical framing members: Southern Yellow Pine, Table 1, Standard grade, pressure treated.
 3. Mill all exposed framing members to match existing form, profile, finish, and sizes exactly.
 4. Plywood sheathing: Structural II, C-C, exterior; or standard sheathing with exterior glue, pressure treated, where specifically shown on the Drawings.
 5. Roof sheathing: southern Yellow Pine, Table 1, No. 2, pressure treated, in thickness and style to match existing.
 6. Building paper: Kraft paper complying with Fed Spec UU-B-790A.
 7. Wood preservative: Ammoniacal copper arsenite, or 5% solution of pentachlorophenol.
 8. Rough hardware:
 - a. Steel items:
 - (1) Comply with ASTM A36 or ASTM A992.
 - (2) Use galvanized at all locations.
 - b. Machine bolts: Comply with ASTM A307.
 - c. Lag bolts: Comply with Fed Spec FF-B-561.
 - d. Nails:
 - (1) Use common except as otherwise noted.
 - (2) Comply with Fed Spec FF-N-1.
 - (3) Use galvanized at all locations.
 - e. Joist hangers: Simpson, Teco, or equal as approved by the

Architect/Engineer, galvanized.

2.3 OTHER MATERIALS

- A. Provide other materials, not specifically described but required for a complete and proper installation, as selected by the Contractor subject to the approval of the Architect/Engineer.

PART 3 - EXECUTION

3.1 SURFACE CONDITIONS

- A. Examine the areas and conditions under which work of this Section will be performed. Correct conditions detrimental to timely and proper completion of the Work. Do not proceed until unsatisfactory conditions are corrected.

3.2 DELIVERIES

- A. Stockpile materials sufficiently in advance of need to assure their availability in a timely manner for this Work.
- B. Make as many trips to the job site as are needed to deliver materials of this Section in a timely manner to ensure orderly progress of the Work.

3.3 COMPLIANCE

- A. Do not permit materials not complying with the provisions of this Section to be brought onto or to be stored at the job site.
- B. Promptly remove non-complying materials from the job site and replace with materials meeting the requirements of this Section.

3.4 WORKMANSHIP

- A. Produce joints which are tight, true, and well nailed, with members assembled in accordance with the Drawings and with pertinent codes and regulations.
- B. Selection of lumber pieces:
 - 1. Carefully select the members.
 - 2. Select individual pieces so that knots and obvious defects will not interfere with

- placing bolts or proper nailing, and will allow making of proper connections.
3. Cut out and discard defects which render a piece unable to serve its intended function.
 4. Lumber may be rejected by the Architect/Engineer, whether or not it has been installed, for excessive warp, twist, bow, crook, mildew, fungus, or mold, as well as for improper cutting and fitting.
- C. Do not shim any framing component.

3.5 GENERAL FRAMING

- A. General
1. In addition to framing operations normal to the fabrication and erection indicated on the drawings, install wood blocking and backing required for the work of other trades.
 2. Set horizontal and sloped members with crown up.
 3. Do not notch, cut, or bore members for pipes, ducts, or conduits, or for other reasons except as shown on the Drawings or as specifically approved in advance by the Architect/Engineer.
 4. Where new members replace existing, and will be exposed to view, mill and dress to match existing members as to size and texture.
- B. Bearings:
1. Make bearings full unless otherwise indicated on the Drawings.
 2. Finish bearing surfaces on which structural members are to rest so as to give sure and even support.
 3. Where framing members slope, cut or notch the ends as required to give uniform bearing surface.

3.6 BLOCKING AND BRIDGING

- A. Install blocking as required to support items of finish and to cut off concealed draft openings, both vertical and horizontal, between ceiling and floor areas.
- B. Bridging:
1. Install wood cross bridging (not less than 2" x 3" nominal), metal cross bridging of equal strength, or solid blocking between joists where the span exceeds 8'-0".
 2. Provide maximum distance of 8'-0" between a line of bridging and a bearing.
 3. Cross bridging may be omitted for roof and ceiling joists where the omission is permitted by code, except where otherwise indicated on the Drawings.
 4. Install solid blocking between joists at points of support and wherever sheathing is discontinuous. Blocking may be omitted where joists are supported on metal hangers.

3.7 ALIGNMENT

- A. On framing members to receive a finished surface, align the finish subsurface to vary not more than 1/8" from the plane of surfaces of adjacent furring and framing members.

3.8 INSTALLATION OF SHEATHING

- A. Placement:
 - 1. Place boards perpendicular and plywood with face grain perpendicular to supports and continuously over at least two supports, except where otherwise shown on the Drawings.
 - 2. Center joints accurately over supports, unless otherwise shown on the Drawings.
- B. Protect wood from moisture by use of waterproof coverings until the wood in turn has been covered with the next succeeding component or finish.

3.9 FASTENINGS

- A. Nailing:
 - 1. Use only common wire nails or spikes of the dimension required by Code, or as shown on the Nailing Schedule, except where otherwise specifically noted on the Drawings.
 - 2. For conditions not covered in the Nailing Schedule provide penetration into the piece receiving the point of not less than 1/2 the length of the nail or spike, provided, however, that 16d nails may be used to connect two pieces of 2" (nominal) thickness.
 - 3. Nail without splitting wood.
 - 4. Pre-bore as required.
 - 5. Remove split members and replace with members complying with the specified requirements.
- B. Bolting:
 - 1. Drill holes 1/16" larger in diameter than the bolts being used.
 - 2. Drill straight and true from one side only.
 - 3. Do not bear bolt threads on wood, but use washers under head and nut where both bear on wood, and use washers under all nuts.
- C. Screws:
 - 1. For lag screws and wood screws, pre-bore holes same diameter as root of threads, enlarging holes to shank diameter for length of shank.

END OF SECTION

SECTION 06200
FINISH CARPENTRY

PART 1 - GENERAL

1.1 DESCRIPTION

- A. Work included: Install wood, nails, screws, and other items as needed, and perform finish carpentry for the construction shown on the Drawings, as specified herein, and as need for a complete and proper installation.

- B. Related work:
 - 1. Documents affecting work of this Section include, but are not necessarily limited to, General Conditions, Supplementary Conditions, and Sections in Part 4 – Summary of the Work of these Specifications.

- J. Preservation requirements:
 - 4. The work of this contract involves a significant historic site. Care shall be taken during all activities to protect and preserve historic and/or archaeological resources.

1.2 QUALITY ASSURANCE

- A. Use adequate numbers of skilled workmen who are thoroughly trained and experienced in the necessary crafts and who are completely familiar with the specified requirements and the methods needed for proper performance of the work of this Section.

- K. The Architect/Engineer reserves the right to have individual workmen, or subcontractors removed from the work when in the Architect/Engineer's opinion, those parties are determined to be damaging historic materials or are not sensitive to the nature of the work.

PART 2 - PRODUCTS

2.1 GRADE STAMPS

- A. Identify lumber by the grade stamp of the West Coast Lumber Inspection Bureau, or such other grade stamp as is approved in advance by the Architect/Engineer.

- B. Identify plywood as to species, grade, and glue type by the stamp of the American Plywood Association.

2.2 MATERIALS

- A. Air dry all finish lumber to maximum 19% moisture content. Do not install "wet" lumber for finish carpentry applications. Provide materials in the quantities needed for the Work

as shown on the Drawings, and meeting or exceeding the following standards of quality:

1. Decorative rafter tails, fascias and miscellaneous trim: Match existing species, or if directed by the Architect/Engineer, Southern Yellow Pine, No. 1/appearance grade, pressure treated and kiln dried after treating.
2. Other materials as specifically identified in the Drawings.
3. All components exposed to view shall match existing size, profile, form and finish exactly.

2.3 OTHER MATERIALS

- A. Provide other materials, not specifically described but required for a complete and proper installation, as selected by the Contractor subject to the approval of the Architect/Engineer.

2.4 SAMPLES

- A. Provide samples of each material, cut and finished to the appropriate profile, prior to installation of any material. Do not commence work until approval from the Architect/Engineer has been obtained.

PART 3 - EXECUTION

3.1 SURFACE CONDITIONS

- A. Examine the areas and conditions under which work of this Section will be performed. Correct conditions detrimental to timely and proper completion of the Work. Do not proceed until unsatisfactory conditions are corrected.

3.2 WORKMANSHIP

- A. Produce joints which are true, tight, and well nailed with all members assembled in accordance with the Drawings.
- B. Jointing:
 1. Make joints to conceal shrinkage; miter exterior joints; cope interior joints; miter or scarf end-to-end joints.
 2. Install trim in pieces as long as possible, jointing only where solid support is obtained.
- C. Fastening:
 1. Install items straight, true, level, plumb, and firmly anchored in place.
 2. Where blocking or backing is required, coordinate as necessary with other trades to ensure placement of required backing and blocking in a timely manner.
 3. Nail trim with finish nails of proper dimension to hold the member firmly in place without splitting the wood.
 4. Nail exterior trim with galvanized nails, making joints to exclude water and setting in waterproof glue or the sealant described in Section 07920 of these

Specifications.

5. On exposed work, set nails for putty.
6. Screw, do not drive, wood screws; except that screws may be started by driving and then screwed home.

3.3 INSTALLATION OF OTHER ITEMS

- A. Install items in strict accordance with the Drawings and the recommended methods of the manufacturer as approved by the Architect/Engineer, anchoring firmly into position at the prescribed locations, straight, plumb, and level.

3.4 FINISHING

- A. Sandpaper finished wood surfaces thoroughly as required to produce a uniformly smooth surface, always sanding in the direction of the grain; except do not sand wood which is designed to be left rough.
- B. No coarse grained sandpaper mark, hammer mark, or other imperfection will be accepted.

3.5 CLEANING UP

- A. Keep the premises in a neat, safe, and orderly condition at all times during execution of this portion of the Work, free from accumulation of sawdust, cut-ends, and debris.
- B. Sweeping:
 1. At the end of each working day, and more often if necessary, thoroughly sweep surfaces where refuse from this portion of the Work has settled.
 2. Remove the refuse to the area of the job site set aside for its storage.
 3. Upon completion of this portion of the Work, thoroughly broom clean all surfaces.

END OF SECTION

SECTION 07540
TPO THERMOPLASTIC SINGLE-PLY ROOFING ADHERED TO
INSULATED WOOD DECK

PART 1 GENERAL

1.1 SECTION INCLUDES

- A. Thermoplastic Single-Ply Roofing.
- B. Roof Insulation.

1.2 RELATED SECTIONS

- A. Section 06100: Rough Carpentry.
- B. Section 07600: Sheet Metal Flashing and Trim.

1.3 REFERENCES

- A. American Society for Testing and Materials (ASTM) - Annual Book of ASTM Standards.
 - 1. ASTM D4263 - Standard Test Method for Indicating Moisture in Concrete by the Plastic Sheet Method.
 - 2. ASTM D6878 - Standard Specification for Thermoplastic Polyolefin (TPO) Sheet Roofing.
- B. U.S. Green Building Council (USGBC).
- C. Leadership in Energy and Environmental Design (LEED).
- D. Underwriters Laboratories (UL) - Roofing Systems and Materials Guide (TGFU R1306).
- E. Cool Roof Rating Council (CRRC).
- F. Sheet Metal and Air Conditioning Contractors National Association, Inc. (SMACNA) - Architectural Sheet.
- G. National Roofing Contractors Association (NRCA).
- H. American Society of Civil Engineers (ASCE).
 - 1. ASCE 7 - Minimum Design Loads for Buildings and Other Structures.

1.4 DEFINITIONS

- A. Roofing Terminology: Refer to ASTM D1079 and the glossary of the National Roofing Contractors Association (NRCA) Roofing and Waterproofing Manual for definitions of roofing terms related to this section.

1.5 PERFORMANCE REQUIREMENTS

- A. Provide an installed roofing membrane and base flashing system that does not permit the passage of water, and will withstand the design pressures calculated in accordance with the most current revision of ASCE 7.
- B. Flex Membrane shall provide all primary roofing materials that are physically and chemically compatible when installed in accordance with manufacturers current application requirements.

1.6 SUBMITTALS

- A. Submit under provisions of Section 01 30 00.
- B. Product Data: Manufacturer's data sheets on each product to be used, including:
 - 1. Preparation instructions and recommendations.
 - 2. Storage and handling requirements and recommendations.
 - 3. Installation methods.
- C. Shop Drawings:
 - 1. Show outline and size of the roof, location and type of penetrations, perimeter and penetration flashing detail references to manufacturer's standard. Details which do not conform to roofing manufacturer's standards shall be identified with separate approval from roofing manufacturer. Details to be employed on the project shall be approved by roofing manufacturer.
- D. Selection Samples: For each finish product specified, two complete sets of color chips representing manufacturer's full range of available colors and patterns.
- E. Verification Samples: For each finish product specified, two samples, minimum size 6 inches (150 mm) square, representing actual product, color, and patterns.

1.7 QUALITY ASSURANCE

- A. Manufacturer Qualifications: Membrane shall provide a roofing system that meets or exceeds all criteria listed in this section.
- B. Source Limitations: Components listed shall be provided by a single manufacturer or approved by the primary roofing manufacturer.
- C. Final Inspection: Manufacturer's representative shall provide a comprehensive final inspection after completion of the roof system. All application errors shall be addressed and final punch list completed.

1.8 REGULATORY REQUIREMENTS

- A. Work shall be performed in a safe, professional manner, conforming to federal, state and local codes.
- B. Exterior Fire Test Exposure: Provide a roofing system achieving a UL Class rating for roof slopes indicated.
 - 1. UL Class A rating.
 - 2. UL Class B rating.
 - 3. UL Class C rating.
- C. Windstorm Classification: Provide a roofing system which will achieve the following Factory Mutual wind uplift rating, as listed in the current FM Approval Guide.

1.9 DELIVERY, STORAGE, AND HANDLING

- A. Deliver roofing materials to the site in original containers, with factory seals intact.
- B. Store pail goods in their original undamaged containers in a clean, dry location within their specified

temperature range.

- C. Do not expose materials to moisture in any form before, during, or after delivery to the site. Reject delivery of materials that show evidence of contact with moisture.
- D. Remove manufacturer supplied plastic covers from materials provided with such. Use "breathable" type covers such as canvas tarpaulins to allow venting and protection from weather and moisture. Cover and protect materials at the end of each work day. Do not remove any protective tarpaulins until immediately before the material will be installed.
- E. Store and dispose of solvent-based materials, and materials used with solvent-based materials, in accordance with requirements of local authorities having jurisdiction.

1.10 PROJECT CONDITIONS

A. Weather:

1. Proceed with roofing only when existing and forecasted weather conditions permit.

1.11 WARRANTY

- A. Manufacturer warrants to the Building Owner, subject to the terms, limitations, and conditions for a period specified, in which the Materials and Workmanship Warranty is effective, the materials installed shall be free from defects in materials supplied and/or defective workmanship provided by the authorized applicator.
 1. The Manufacturer's Technical Service Representative shall inspect the completed roof system, and upon acceptance, the manufacturer shall issue the specified warranty commencing on the Date of Substantial Completion
 2. The Roofing System shall receive the manufacturer's standard ten (10) year guarantee of watertightness.
- B. Sheet Metal Warranty: Materials supplied by the roofing manufacturer.
 1. Materials shall be free of defects in material and workmanship for five years after shipment. Defective materials will be repaired or replaced at manufacturer's option. Manufacturer shall not be liable for direct or consequential damages arising from the installation of materials. No other express or implied warranties apply to the products.

PART 2 PRODUCTS

2.1 MANUFACTURERS

- A. Acceptable Manufacturer: Flex Membrane International Corp
- B. Substitutions: GAF Company, Carlisle, Genflex.
- C. Requests for substitutions will be considered in accordance with provisions of this project.

2.2 SYSTEM

- A. TPO Roofing System
 1. Color: White
 2. Roof System: Provide and install an Adhered, Thermoplastic, CRRC approved roofing membrane to a

wood deck.

2.3 MEMBRANE

- A. Membrane: The roofing membrane shall meet or exceed the requirements of ASTM D6878 standard for Thermoplastic Polyolefin (TPO) Based Sheet Roofing.
- B. TPO Membrane:
 - 1. TPO Plus 45 Mil Reinforced
 - 2. TPO Plus 60 Mil Reinforced
 - 3. TPO Plus 80 Mil Reinforced

2.4 ACCESSORY MATERIALS:

- A. Adhesives:
 - 1. TPO Bonding Adhesive: Solvent-based Bonding Adhesive: Solvent based adhesive for use with TPO membranes.
 - 2. TPO Low VOC Bonding Adhesive: Low VOC solvent-based Bonding Adhesive: Solvent based rubberized adhesive for use with TPO membranes.
 - 3. TPO Cut-Edge Sealant: Solvent based liquid, required to protect field cut edges of TPO membranes. Applied directly from a squeeze bottle.
 - 4. TPO Weathered Membrane Cleaner: Solvent based seam cleaner used to clean exposed or contaminated seam prior to heat welding.
- B. Fasteners:
 - 1. Plywood Decks: screw type fasteners applied in a Factory Mutual approved pattern and method.
 - a. Screws, Corrosion Resistant # 10 Coating
 - b. SFS Intec Inc., Dekfast Fastening System, C-2 type, corrosion resistant only.
 - c. OMG Inc. Fasteners, screws long and short, Endurion coated only.
 - 2. Solid Wood Decks: screw or nail type fasteners:
 - a. Screws, Corrosion Resistant # 10 Coating
 - b. SFS Intec, Dekfast Fastening System, C-2 type, corrosion resistant only.
 - c. OMG Inc., Fasteners, screws long and short, Endurion coated only.
- B. Base Sheet:
 - 1. Base sheets or ply sheets installed over substrate or insulation system as an integrated component of Flex built up roofing system.
 - a. Flex SBS 80 mil S/S Base Sheet.
 - b. Premium Flex Ply Roofing Felt.
- C. Wood Nailers:
 - 1. Number 2 grade lumber minimum salt treated for rot and fire resistance.
 - a. Wolmanized.
 - b. Osiose treated.
 - c. Pressure treated.

PART 3 EXECUTION

3.1 EXAMINATION

- A. Verify that the surfaces and site conditions are ready to receive work.

- B. Verify that the deck is supported and secured.
- C. Verify that the deck is clean and smooth, free of depressions, waves, or projections, and properly sloped to drains, valleys, eaves, scuppers or gutters.
- D. Verify that the deck surfaces are dry and free of ice or snow.
- E. Verify that all roof openings or penetrations through the roof are solidly set, and that all flashings are tapered.

3.2 SUBSTRATE PREPARATION

- A. Plywood Deck:
 - 1. Plywood sheathing shall be exterior grade, minimum 4 ply, and not less than 15/32 inch (12 mm) thick.
 - 2. Preservatives or fire retardants used to treat the decking shall be compatible with roofing materials.
 - 3. The deck shall be installed over joists that are spaced 24 inches (610 mm) o.c. or less.
 - 4. The deck shall be installed so that all four sides of each panel bear on and are secured to joist and cross blocking. "H" clips are not acceptable.
 - 5. Panels shall be installed with a 1/8 inch to 1/4 inch (3 mm to 6 mm) gap between panels and shall match vertically at joints to within 1/8 inch (3 mm).
 - 6. Decking shall be kept dry and roofed promptly after installation.

3.3 INSTALLATION

- A. Install roof system in accordance with manufacturer's instructions.
- B. Wood Nailers:
 - 1. Locate and install along gravel stops and drip edges and other areas as required by membrane manufacturer.
 - 2. Anchor nailer to structural deck with manufacturer's approved fasteners, spaced appropriately for the specified installation; minimum withdrawal resistance 100 pounds (45 kg) per fastener.
- C. Membrane Installation:
 - 1. Place membrane so that wrinkles and buckles are not formed. Any wrinkles or buckles must be removed from the sheet prior to permanent attachment. Roof membrane shall be fully adhered immediately after it is rolled out, followed by welding to adjacent sheets.
 - 2. Overlap roof membrane a minimum of 3" (15 cm) for side laps and 3" (15 cm) for end laps.
 - 3. Install membrane so that the side laps run across the roof slope lapped towards drainage points.
 - 4. All exposed sheet corners shall be rounded a minimum of 1".
 - 5. Use full width rolls in the field and perimeter region of roof.
 - 6. Use appropriate bonding adhesive for substrate surface, applied with a solvent-resistant roller, brush or squeegee.
 - 7. Apply bonding adhesive at 3 squares of finished, mated surface area per 5 gallons (Solvent Based) and 5 squares of finished, mated surface area per 5 gallons (Water Based). A greater quantity of bonding adhesive may be required based upon the substrate surface condition.
 - 8. Prevent seam contamination by keeping the adhesive application a few inches back from the seam area.

9. Adhere approximately one half of the membrane sheet at a time. One half of the sheet's length shall be folded back in turn to allow for adhesive application. Lay membrane into adhesive once the bonding adhesive is tacky to the touch.
10. Roll membrane with a weighted roller to ensure complete bonding between adhesive and membrane.
11. Membrane laps shall be heat-welded together. All welds shall be continuous, without voids or partial welds. Welds shall be free of burns and scorch marks.
12. Weld shall be a minimum of 1-1/2" in width for automatic machine welding and a minimum 2" in width for hand welding.
13. All cut edges of reinforced membrane must be sealed with Flex TPO Cut Edge Sealant.

D. Roof Edges:

1. Roof edge flashings are applicable for gravel stop and drip edge conditions as well as for exterior edges of parapet walls.
2. Flash roof edges with metal flanges nailed 4 inches (102 mm) O.C. to pressure-treated wood nailers. Where required, hot-air weld roof membrane to coated metal flanges.
3. When the fascia width exceeds 4 inches (102 mm), coated metal roof edging must be attached with a continuous cleat to secure the lower fascia edge. The cleat must be secured to the building no less than 12 inches (305 mm) O.C.
4. Alternatively, roof edges may be flashed with a 2-piece snap on fascia system, adhering the roof membrane to a metal cant and face nailing the membrane 8" on center prior to installing a snap-on fascia.
5. Flash roof edge scuppers with a coated metal insert that is mechanically attached to the roof edge and integrated as a part of the metal edging.

3.4 CLEAN-UP

- A. All work areas are to be kept clean, clear and free of debris at all times.
- B. Do not allow trash, waste, or debris to collect on the roof. These items shall be removed from the roof on a daily basis.
- C. All tools and unused materials shall be collected at the end of each workday and stored properly off of the finished roof surface and protected from exposure to the elements.
- D. Dispose of or recycle all trash and excess material in a manner conforming to current EPA regulations and local laws.
- E. Properly clean the finished roof surface after completion, and make sure the drains and gutters are not clogged.
- F. Clean and restore all damaged surfaces to their original condition.

END OF SECTION

SECTION 07600
FLASHING AND SHEET METAL / GUTTERS AND DOWNSPOUTS

PART 1 - GENERAL

1.1 DESCRIPTION

- A. Work included: Provide flashing and sheet metal not specifically described in other Sections of these Specifications but required to prevent penetration of water through the exterior shell of the building.
- B. Related work:
 - 1. Documents affecting work of this Section include, but are not necessarily limited to, General Conditions, Supplementary Conditions, and Sections in Division 1 of these Specifications.

1.2 QUALITY ASSURANCE

- A. The work of this project involves a significant historic site. All work activities must be undertaken with sufficient care to protect this historic resource and must be supervised by personnel who are familiar with the Secretary of Interior's Standards for Rehabilitation.
- B. Due to the sensitive historic nature of this project, general contractors and certain trades must meet prequalification requirements.
- C. Use adequate numbers of skilled workmen who are thoroughly trained and experienced in the necessary crafts and who are completely familiar with the specified requirements and the methods needed for proper performance of the work of this Section.
- D. Take all appropriate measures necessary to correct inferior work as identified by the architect. Protect historic fabric during all operations. No historic materials shall be removed from the site without prior approval of architect. The architect reserves the right to have individual workmen removed from individual activities or the project entirely, if in the architect's judgment, the quality of work being performed is inappropriate, inferior, or detrimental to historic materials.
- E. Refer to photographic details in the Specifications and/or on the Drawings for additional historic preservation information and project requirements.
- F. All work must comply with the Secretary of the Interiors Standards for Rehabilitation, as administered by the Florida Department of State, Division of Historic Resources.
- G. In addition to complying with pertinent codes and regulations, comply with pertinent recommendations contained in current edition of "Architectural Sheet Metal Manual" published by the Sheet Metal and Air Conditioning Contractors National Association (SMACNA).
- H. Standard commercial items may be used for flashing, trim, reglets, and similar purposes provided such items meet or exceed the quality standards specified.

1.3 SUBMITTALS

- A. Product data: Within 45 calendar days after the Contractor has received the Owner's Notice to Proceed, submit:
 - 1. Materials list of items proposed to be provided under this Section;
 - 2. Manufacturer's specifications and other data needed to prove compliance with the specified requirements;
 - 3. Shop Drawings in sufficient detail to show fabrication, installation, anchorage, and interface of the work of this Section with the work of adjacent trades;
 - 4. Manufacturer's recommended installation procedures which, when approved by the Architect, will become the basis for accepting or rejecting actual installation procedures used on the Work.

1.4 PRODUCT HANDLING

- A. Comply with pertinent provisions of Section 01640.

PART 2 – PRODUCTS

2.1 MATERIALS AND GAGES

- A. Where sheet metal is required, and no material or gage is indicated on the Drawings, provide the highest quality and gage commensurate with the referenced standards.

2.2 GALVANIZED IRON

- A. Provide sheet metal or sheet iron of a standard brand of open-hearth copper-bearing steel, copper-molybdenum iron, or pure iron sheets.
- B. Zinc coating:
 - 1. Where galvanizing is required, provide zinc coating by hot-dip galvanize to all surfaces.
 - 2. Weight:
 - a. Provide not less than 1-1/4 oz per sq ft, not more than 1-1/2 oz per sq ft, to surfaces required to be galvanized.
 - 3. Comply with ASTM A93.

2.3 NAILS, RIVETS, AND FASTENERS

- A. Use only soft iron rivets having rust-resistive coating, galvanized nails, and cadmium plated screws and washers in connection with galvanized iron and steel.

2.4 FLUX

- A. Where flux is required, use raw muriatic acid.

2.5 SOLDER

- A. Where solder is required, comply with ASTM B32.

2.6 COPPER

- A. Sheet Copper: Sheet copper shall be standard copper for building construction or equivalent. Only domestic materials shall be used when available. Any sheet metal shown on drawings and not otherwise specified shall be 16oz. Cold rolled copper. Sheets shall conform to ASTM Specifications B370 or Federal Specifications QQ-C-576.
- B. Lead Coating: Where lead coated copper is specified or noted on drawings, copper shall be coated on both sides with lead weighing 6 to 7 1/2 lbs. per 100 sq. ft. for each side. Lead coated sheet shall conform to ASTM specification B101, Type 1, Class A.

Weights of lead coated copper specified shall be weights of sheet copper exclusive of lead coating. All lead coated copper shall have finish not rougher than Revere Leadtex.

Note 1. Sheet copper, both plain and lead coated, shall not be installed in contact with or in close proximity to fire retardant lumber. Refer to manufacturer's specifications and warranties, for use with special types of exterior fire retardant treatments.

2.7 FASTENERS

Nails used for fastening copper shall be copper or hardware bronze of Stronghold type, or equal, with large flat head. They shall not be smaller than No. 12 Stubs gauge (0.109") and of sufficient length to penetrate roof boarding not less than 3/4".

Rivets shall be of hard copper, brass, or bronze.

Screws and bolts used for fastening copper shall be copper, bronze, brass or stainless steel (passive).

Note 2: Copper or bronze fasteners shall not be used to secure sheet copper to fire retardant treated lumber.

2.8 CLEATS

Cleats shall be 2" wide by about 3" long and shall be made of Revere 16 oz. cold rolled copper, unless otherwise specified. One end shall be locked into seams or into folded edge of copper sheets. Other end shall be nailed with two nails and folded back over nail heads, unless otherwise noted on drawings. When expansion cleats are used, they shall be the same overall dimensions as fixed cleats.

2.9 SOLDER

Where used on plain copper, solder composition shall be 50% block tin and 50% pig lead. Solder shall conform to ASTM specification B32 or Federal Specification QQ-S-571.

2.10 FLUX

Flux shall be muriatic acid killed with zinc, or approved brand of soldering flux. Acid shall be thoroughly washed off after soldering is completed.

2.11 SYNTHETIC OR RUBBER BASE SEALANTS

Butyl sealants shall be those conforming to Federal Specification TT-S-001657. Use shall be in conformance with manufacturer=s recommendations.

One part polysulfide sealants shall be those conforming with Federal Specification TT-S-00230C Type II, Class A. Use shall be in conformance with manufacturer=s recommendation.

One part polyurethane sealants shall be those conforming with Federal Specification TT-S-00230C Type II, Class B. Use shall be in conformance with manufacturer=s recommendations.

Silicone sealants shall be those conforming to Federal Specification TT-S-00230C Type II, Class A. Use shall be in conformance with manufacturer=s recommendations.

Butyl tape shall be of a type produced and recommended by a reputable manufacturer for architectural copper applications, and shall be used in conformance with that manufacturer=s recommendations.

2.12 HUNG MOLDED GUTTERS

- A. Hung molded gutters forming combination cornice and gutter shall conform to size and design shown on drawings. They shall be constructed of 20 oz. cold rolled copper sheets 8' or 10' long. Ends of each length shall be joined by 1" lapped, riveted and soldered seam. Rivets shall be 3/16" in diameter with copper burrs: they shall be spaced 2" apart.

Outer edge of gutter shall be folded over continuous 3/4" X 3/16" brass or copper stiffening bar. Rear edge shall extend up on roof slope under copper, slate, tile or shingles at least 6". It shall be attached by cleats spaced 24" apart

- or shall terminate, at roof edge, in 3/4" fold into which shall be folded ends of copper roofing sheets or separate apron piece. Rear edge shall be at least 1" higher than front edge of gutter.

Transverse gutter braces, formed from 20 oz. cold rolled copper 3" wide, shall be bent to form channel 1 1/2" wide with 3/4" flanges. They shall be attached with rivets and solder across gutter and shall be spaced 3' apart.

Straps, where required, shall be formed of half-hard copper or half-hard C26000 brass by Revere, 1"x 1/8". They shall be spaced 3' apart and extend up on roof deck 4" under roofing. They shall be attached to the roof deck by two countersunk brass screws, and riveted or bolted either to gutter brace or outer edge of gutter.

Hangers shall be formed of half-hard copper or half-hard C26000 brass by Revere, 1"X 1/8". They shall be spaced not more than 3' apart. They shall be secured to either fascia or structure by two countersunk brass screws. They shall extend outwardly under the gutter for support - and up front

face (as shown on drawings).

Expansion joints shall be installed on long straight runs at regular intervals of 48'. Runs less than 48' shall have expansion joint at center. At inside and outside corners, expansion joints shall be placed 24' from corner. Expansion joints shall be constructed as specified under built-in gutters.

- B. Hung gutters or eave troughs shall be made of 16 oz. cold rolled copper in 8' or 10' lengths. Ends of each length shall be joined by lapped, riveted and soldered seams. Tongue-and-groove slip expansion joint shall be installed at center of all straight runs 50' to 60' long. In straight runs longer than 60', slip expansion joints shall be installed at intervals of not more than 50'. Groove of slip joint shall be filled with soft grade sealant or a thick mixture of white lead paste. Hangers shall be of adjustable shank and circle type, secured by brass screws. Hangers shall be spaced not more than 32" apart. End pieces, miters and outlets shall be provided where required. Width of gutters shall be 5" unless otherwise indicated.
- C. Outlet tubes that connect to outside leaders or downspouts shall be formed of 16 oz. cold rolled copper, with locked and soldered longitudinal seam. Upper end of tube shall be flanged 1/2" and soldered to gutter lining. Tube shall extend into leader at least 3".
- D. Strainers shall be provided at all outlet tubes. They shall be wire basket type formed of No. 14 B&S gauge copper wire, or cast bronze, and shall fit snugly in outlet tube.

2.13 OTHER MATERIALS

- A. Provide other materials, not specifically described but required for a complete and proper installation, as selected by the Contractor subject to the approval of the Architect.

PART 3 - EXECUTION

3.1 SURFACE CONDITIONS

- A. Examine the areas and conditions under which work of this Section will be performed. Correct conditions detrimental to timely and proper completion of the Work. Do not proceed until unsatisfactory conditions are corrected.

3.2 WORKMANSHIP

- A. General:
 - 1. Form sheet metal accurately and to the dimensions and shapes required, finishing molded and broken surfaces with true, sharp, and straight lines and angles and, where intercepting other members, coping to an accurate fit and soldering securely.
 - 2. Unless otherwise specifically permitted by the Architect, turn exposed edges back 1/2".
- B. Form, fabricate, and install sheet metal so as to adequately provide for expansion and contraction in the finished Work.
- C. Weatherproofing:
 - 1. Finish watertight and weathertight where so required.

2. Make lock seam work flat and true to line, sweating full to solder.
3. Make lock seams and lap seams, when soldered, at least 1/2" wide.
4. Where lap seams are not soldered, lap according to pitch, but in no case less than 3".
5. Make flat and lap seams in the direction of flow.

D. Joints:

1. Join parts with rivets or sheet metal screws where necessary for strength and stiffness.
2. Provide suitable watertight expansion joints for runs of more than 40'-0", except where closer spacing is indicated on the Drawings or required for proper installation.

E. Nailing:

1. Whenever possible, secure metal by means of clips or cleats, without nailing through the exterior metal.
2. In general, space nails, rivets, and screws not more than 8" apart and, where exposed to the weather, use lead washers.
3. For nailing into wood, use barbed roofing nails 1-1/4" long by 11 gage.
4. For nailing into concrete, use drilled plugholes and plugs.

F. Copper Surfaces:

Surfaces to be covered with sheet metal shall be smooth and free from defects of every description. All such surfaces shall be cleaned of dirt, rubbish and other foreign materials before sheet metal work is started. All projecting nails shall be driven flush with roof boarding.

G. Tinning:

Edges of all sheets of uncoated copper to be soldered shall be tinned with solder on both sides for width not less than 1 1/2". Lead in contact with solder shall be thoroughly mechanically cleaned to produce a bright finish.

H. Soldering:

All soldering shall be done slowly with well heated coppers - to heat sheet thoroughly and to sweat solder completely through full width of seam. Ample solder shall be used and seam shall show at least one full inch of evenly flowed solder. Wherever possible, all soldering shall be done in flat position. Seams on slopes steeper than 45 degree shall be soldered a second time.

I. Soldering coppers:

Soldering shall be done with heavy soldering coppers of blunt design, properly tinned before using. For flat seam work and gutters they shall weigh not less than 10 lbs. per pair - except, when gas-heated soldering torch is used, copper itself shall weigh not less than 3 lbs.

3.3 EMBEDMENT

- A. Embed metal in connection with roofs in a solid bed of sealant, using materials and methods described in Section 07920 of these Specifications or other materials and methods approved in advance by the Architect.

3.4 SOLDERING

A. General:

1. Thoroughly clean and tin the joint materials prior to soldering.
2. Perform soldering slowly, with a well heated copper, in order to heat the seams thoroughly and to completely fill them with solder.

3. Perform soldering with a heavy soldering copper of blunt design, properly tinned for use.
4. Make exposed soldering on finished surfaces neat, full flowing, and smooth.

B. After soldering, thoroughly wash acid flux with a soda solution.

3.5 TESTS

A. Upon request of the Architect, demonstrate by hose or standing water that the flashing and sheet metal are completely watertight.

END OF SECTION

**SECTION 07920
SEALANTS AND CAULKING**

PART 1 - GENERAL

1.1 DESCRIPTION

- A. Work included: Throughout the Work seal and calk joints where shown on the Drawings and elsewhere as required to provide a positive barrier against passage of moisture and passage of air.
- B. Related work:
 - 1. Documents affecting work of this Section include, but are not necessarily limited to, General condition, Supplementary Conditions, and Sections in Division 1 of these Specifications.

1.2 QUALITY ASSURANCE

- A. The work of this project involves a significant historic site. The Waterworks Building dates from 1898 with significant additions through 1926. All work activities must be undertaken with sufficient care to protect this historic resource and must be supervised by personnel who are familiar with the Secretary of Interior=s Standards for Rehabilitation.
- B. Due to the sensitive historic nature of this project, general contractors and certain trades must meet prequalification requirements.
- C. Use adequate numbers of skilled workmen who are thoroughly trained and experienced in the necessary crafts and who are completely familiar with the specified requirements and the methods needed for proper performance of the work of this Section.
- D. Take all appropriate measures necessary to correct inferior work as identified by the architect. Protect historic fabric during all operations. No historic materials shall be removed from the site without prior approval of architect. The architect reserves the right to have individual workmen removed from individual activities or the project entirely, if in the architect's judgment, the quality of work being performed is inappropriate, inferior, or detrimental to historic materials.
- E. Refer to photographic details in the Specifications and/or on the Drawings for additional historic preservation information and project requirements.
- F. All work must comply with the Secretary of the Interiors Standards for Rehabilitation, as administered by the Florida Department of State, Division of Historic Resources.

1.3 SUBMITTALS

- A. Comply with pertinent provisions of Section 01340 of these Specifications.
- B. Product data: Within 45 calendar days after the Contractor has received the Owner's Notice to Proceed, submit:
 - 1. Materials list of items proposed to be provided under this Section;
 - 2. Manufacturer's specifications and other data needed to prove compliance with

- the specified requirements;
3. Manufacturer's recommended installation procedures which, when approved by the Architect, will become the basis for accepting or rejecting actual installation procedures used on the Work.

- C. Samples: Accompanying the submittal described above, submit Samples of each sealant, each backing material, each primer, and each bond breaker proposed to be used.

1.4 PRODUCT HANDLING

- A. Comply with pertinent provisions of Section 01640 of these Specifications.
- B. Do not retain at the job site material which has exceeded the shelf life recommended by its manufacturer.

PART 2 - PRODUCTS

2.1 SEALANTS

- A. Except as specifically otherwise approved by the Architect, use only the types of sealants described in this Article.
- B. Provide one component, nonmodulus sealant complying with Fed Spec TT-S-00230C, Class A, Type II with each color of sealant and each class of sealant the product of a single manufacturer selected from the following TREMCO products, or equal products approved by the Architect prior to award of Bid:
 1. Class A (for non-traffic bearing horizontal surfaces):
 - a. "Vulkem 921"
 - b. TREMCO Dymonic FC.
 2. Class B (for vertical surfaces):
 - a. "Vulkem 921"
 - b. TREMCO Dymonic FC
 3. For other services, provide products especially formulated for the proposed use and approved in advance by the Architect.
- C. Colors:
 1. Colors for each sealant installation will be selected by the Architect from standard colors normally available from the specified manufacturers.
 2. Should such standard color not be available from the approved manufacturer except at additional charge, provide such colors at no additional cost to the Owner.
- D. In concealed installations, and in partially or fully exposed installations where so approved by the Architect, use standard gray or black sealant.

2.2 PRIMERS

- A. Use only those primers which are non-staining, have been tested for durability on the surfaces to be sealed, and are specifically recommended for this installation by the manufacturer of the sealant used.

2.3 BACKUP MATERIALS

- A. Use only those backup materials which are specifically recommended for this installation by the manufacturer of the sealant used, which are non-absorbent, and which are non-staining.
- B. Acceptable types include:
 1. Closed-cell resilient urethane or polyvinyl-chloride foam;
 2. Closed-cell polyethylene foam;
 3. Closed-cell sponge of vinyl or rubber;

2.4 BOND-PREVENTATIVE MATERIALS

- A. Use only one of the following as best suited for the application, and as recommended by the manufacturer of the sealant used:
 1. Polyethylene tape, pressure-sensitive adhesive, with the adhesive required only to hold tape to the construction materials as indicated;
 2. Aluminum foil complying with MIL-A-148E;
 3. Wax paper complying with Fed Spec UU-P-270.

2.5 MASKING TAPE

- A. For masking around joints, provide masking tape complying with Fed Spec UU-T-106c.

2.6 OTHER MATERIALS

- A. Provide other materials, not specifically described but required for a complete and proper installation, as selected by the Contractor subject to the approval of the Architect.

PART 3 - EXECUTION

3.1 SURFACE CONDITIONS

- A. Examine the areas and conditions under which work of this Section will be performed. Correct conditions detrimental to timely and proper completion of the Work. Do not proceed until unsatisfactory conditions are corrected.

3.2 PREPARATION

A. Concrete and ceramic tile surfaces:

1. Install only on surfaces which are dry, sound, and well brushed, wiping free from dust.
2. At open joints, remove dust by mechanically blown compressed air if so required.
3. Use solvent to remove oil and grease, wiping the surfaces with clean rags.
4. Where surfaces have been treated, remove the surface treatment by sandblasting or wire brushing.
5. Remove laitance and mortar from joint cavities.
6. Where backstop is required, insert the approved backup material into the joint cavity to the depth needed.

Steel surfaces:

1. Steel surfaces in contact with sealant:
 - a. Sandblast as required to achieve acceptable surface for bond and must be approved in advance by the Architect.
 - b. If sandblasting is not practical, or would damage adjacent finish, scrape the metal or wire brush to remove mill scale.
 - c. Use solvent to remove oil and grease, wiping the surfaces with clean rags.
2. Remove protective coatings on steel by sandblasting or by using a solvent which leaves no residue.

Aluminum surfaces:

1. Aluminum surfaces in contact with sealant:

Remove temporary protective coatings, dirt, oil, and grease.
When masking tape is used for protective cover, remove the tape just prior to applying the sealant.
2. Use only such solvents to remove protective coatings as are recommended for that purpose by the manufacturer of the aluminum work, and which are non-staining.

INSTALLATION OF BACKUP MATERIAL

- A. Use only the backup material recommended by the manufacturer of the sealant used, and approved by the Architect for the particular installation, compressing the backup material 25% to 50% to achieve a positive and secure fit.
- B. When using backup of tube or rod stock, avoid lengthwise stretching of the material. Do not twist or braid hose or rod backup stock.

3.4 PRIMING

- A. Use only the primer recommended by the manufacturer of the sealant, and approved by the Architect for the particular installation, applying in strict accordance with the manufacturer's recommendations as approved by the Architect.

3.5 BOND-BREAKER INSTALLATION

- A. Provide an approved bond-breaker where recommended by the manufacturer of the sealant, and where directed by the Architect, adhering strictly to the installation recommendations as approved by the Architect.

3.6 INSTALLATION OF SEALANTS

- A. Prior to start of installation in each joint, verify the joint type according to details on the Drawings, or as otherwise directed by the Architect, and verify that the required proportion of width of joint to depth of joint has been secured.
- B. Equipment:
 - 1. Apply sealant under pressure with power-actuated hand gun, or by other appropriate means.
 - 2. Use guns with nozzle of proper size, and providing sufficient pressure to completely fill the joints as designed.
- C. Thoroughly and completely mask joints where the appearance of sealant on adjacent surfaces would be objectionable.
- D. Install the sealant in strict accordance with the manufacturer's recommendation as approved by the Architect, thoroughly filling joints to the recommended depth.
- E. Tool joints to the profile shown on the Drawings, or as otherwise required if such profiles are not shown on the Drawings.
- F. Cleaning up:
 - 1. Remove masking tape immediately after joints have been tooled.
 - 2. Clean adjacent surfaces free from sealant as the installation progresses, using solvent or cleaning agent recommended by the manufacturer of the sealant used.

END OF SECTION

**SECTION 08420
ALUMINUM ENTRANCES**

PART 1 – GENERAL

1.1 DESCRIPTION

- A. Work included: Provide aluminum entrances where shown on the Drawings, as specified herein, and as needed for a complete and proper installation.
- B. Related work:
 - 3. Documents affecting work of this Section include, but are not necessarily limited to, General Conditions, Supplementary Conditions, and Sections in Part 4 Scope of Work & General Requirements of these Specifications.

1.2 QUALITY ASSURANCE

- A. Use adequate numbers of skilled workmen who are thoroughly trained and experienced in the necessary crafts and who are completely familiar with the specified requirements and the methods needed for proper performance of the work of this Section.

1.3 SUBMITTALS

- A. Comply with pertinent provisions of Section 01300 of these Specifications.
- B. Product data: Within sixty (60) calendar days after the Contractor has received the Owner's Notice to Proceed, submit:
 - 1. Materials list of items proposed to be provided under this Section;
 - 2. Manufacturer's specifications and other data needed to prove compliance with the specified requirements;
 - 3. Shop drawings in sufficient detail to show fabrication, installation, anchorage, and interface of the work of this Section with the work of adjacent trades;
 - 4. Manufacturer's recommended installation procedures which, when approved by the Architect, will become the basis for accepting or rejecting actual installation procedures used on the Work.
- C. Samples: Accompanying the Shop Drawings, submit:
 - 1. Samples of each exposed member.
 - 2. Samples of finish, showing complete range of color from darkest to lightest proposed for use on this Work. Samples, when approved by the Architect, will be used to verify that finish actually furnished is within the approved range.

1.5 PRODUCT HANDLING

- A. Comply with pertinent provisions of these specifications.

1.6 WARRANTY

- A. Upon completion of this portion of the Work, and as a condition of its acceptance, deliver to the Architect two copies of a written Warranty agreeing to replace work of this Section which fails due to defective materials or workmanship within two (2) years after Date of Substantial Completion as that

Date is determined in accordance with the General Conditions.

- B. Failure due to defective materials or workmanship is deemed to include, but not be limited to:
 - 1. Failures in operation of operating component or components;
 - 2. Leakage or air infiltration in excess of the specified standard;
 - 3. Deterioration of finish to an extent visible to the unaided eye;
 - 4. Defects which contribute to unsightly appearance, potential safety hazard, or potential untimely failure of the Work of this Section or the Work as a whole.

PART 2 – PRODUCTS

2.1 ALUMINUM ENTRANCES

- A. Provide aluminum entrances in the dimensions and arrangements shown on the Drawings.
 - 1. Main entrance doors: The basis of design is Special-Lite Doors.
 - 2. Equal products of other manufacturers will be allowed based on design compliance including:
 - a. Corrim Company
 - b. Oshkosh Door Company
 - c. Tiger Door Company
 - d. Dortek Coompany
- B. Finish all exposed aluminum to match existing systems using the manufacturer’s standard finishes.

2.2 FINISH HARDWARE

- A. Prepare for, receive, and install the finish hardware furnished under this section, as shown on the drawings, and in accordance with approved Submittals.
- B. Procedures:
 - 1. Perform all fitting of finish hardware to doors and frames at the factory; except do not drill or tap for surface mounted items until time of installation at the site.
 - 2. Comply with finish hardware manufacturer’s instructions and template requirements.
 - 3. Use concealed fasteners to the maximum extent practicable.

2.3 FABRICATION

- A. Fabricate in strict accordance with the manufacturers’ specifications and Shop Drawings as approved by the architect, prefabricating in the shop to the maximum extent practicable.
- B. Provide hairline fit at joints, with smooth coninuity of line and accurate relation of planes and angles. Securely fasten.

PART 3 – EXECUTION

3.1 SURFACE CONDITIONS

- A. Examine the areas and conditions under which work of this Section will be performed. Correct conditions detrimental to timely and proper completion of the Work. Do not proceed until unsatisfactory conditions are corrected.

3.2 COORDINATION

- A. Coordinate as required with other trades to assure proper and adequate provision in the work of those trades for interface with the work of this Section.
- B. Make measurements as required in the field to assure proper fit.

3.3 INSTALLATION

- A. Install the work of this Section in strict accordance with the original design, the approved Shop Drawings, pertinent requirements of governmental agencies having jurisdiction, and the manufacturer's recommended installation procedures as approved by the Architect, anchoring all components firmly into position for long life.
- B. Remove protective coating completely from exposed surfaces as soon as progress of the Work will permit with safety.
- C. When glazing is performed under this Section, provide the types of glass required and glaze in accordance with pertinent provisions of these Specifications and all applicable codes, laws, and ordinances of the City of Key West and the State of Florida.

END OF SECTION

PAINING

PART 1 - GENERAL

1.1 DESCRIPTION

- A. Work included: Paint and finish the exterior and interior exposed surfaces listed on the Painting Schedule shown on the drawings as specified herein, and as needed for a complete and proper installation.
- B. Related work:
1. Documents affecting work of this Section include, but are not necessarily limited to, Sections in Part 4 – Summary of the Work, of these Specifications.
 2. Priming or priming and finishing of certain surfaces may be specified to be factory-performed or installer-performed under pertinent other Sections.
- C. Work covered in this Section includes:
1. Painting all exterior concrete and plaster surfaces as called for in the finish schedule.
 2. Painting all exterior trim.
 3. Painting and finishing any other work requiring finishing, but left unfinished by other people.
- D. Work not included:
1. Unless otherwise indicated, painting other than protective prime coats, is not required on surfaces in concealed areas and inaccessible areas, and beam bearing pockets.
 2. Metal surfaces of chromium plate, copper, bronze, and similar finished materials will not require painting under this Section except as may be so specified.
 3. Do not paint moving parts of operating units; mechanical or electrical parts such as valve operators; linkages; sensing devices; and motor shafts, unless otherwise indicated.
 4. Do not paint over required labels or equipment identification, performance rating, name, or nomenclature plates.
- E. Definitions:
1. "Paint," as used herein, means coating systems materials including primers, emulsions, epoxy, enamels, sealers, fillers, and other applied materials whether used as prime, intermediate or finish coats.

1.2 QUALITY ASSURANCE

- A. Use adequate numbers of skilled workmen who are thoroughly trained and experienced in the necessary crafts and who are completely familiar with the specified requirements and the methods needed for proper performance of the work of this Section.
- B. Paint coordination:
1. Provide finish coats which are compatible with the prime coats actually used.
 2. Review other Sections of these Specifications as required, verifying the prime coats to be used and assuring compatibility of the total coating system for the various substrata.
 3. Upon request, furnish information on the characteristics of the specific finish materials to assure that compatible prime coats are used.
 4. Provide barrier coats over non-compatible primers, or remove the primer and re-prime as

- required.
5. Notify the Architect/Engineer in writing of anticipated problems in using the specified coating systems over prime-coatings supplied under other Sections.

1.3 SUBMITTALS

- A. Product data: Within 35 calendar days after the Contractor has received the Owner' Notice to Proceed, submit:
 1. Materials list of items proposed to be provided under this Section;
 2. Manufacturer's specifications and other data needed to prove compliance with the specified requirements.

- B. Samples:
 1. Following the selection of colors and glosses by the Architect/Engineer, as described under "Color Schedules" in Part 2 of this Section, submit Samples for the Architect/Engineer's review.
 - a. Provide Samples of each color and each gloss for each material on which the finish is specified to be applied.
 - b. Except as otherwise directed by the Architect/Engineer, make Samples approximately 8" x 10" in size.
 - c. If so directed by the Architect/Engineer, submit Samples during progress of the Work in the form of actual application of the approved materials on actual surfaces to be painted.
 2. Revise and resubmit each Sample as requested until the required gloss, color, and texture is achieved. Such Samples, when approved, will become standards of color and finish for accepting or rejecting the work of this Section.
 3. Do not commence finish painting until approved Samples are on file at the job site, or applied to the designated areas of the project.
 4. The Painting Contractor shall be responsible for the finish of his work and shall not start painting until the surfaces are in proper condition to receive paint. If the Contractor considers any surfaces unsuitable to a degree that they cannot be corrected by scraping or sanding, he shall report this to the Architect/Engineer before applying any materials to same. Starting his own work shall be considered an acceptance of the surfaces.

1.4 PRODUCT HANDLING

- A. Comply with manufacturer's recommendations.

1.5 JOB CONDITIONS

- A. Apply solvent-thinned paints as permitted by the manufacturers' printed instruction as approved by the Architect/Engineer.

- B. Weather conditions:
 1. Do not apply paint in rain, fog, or mist; or when the relative humidity exceeds 90%; or to damp or wet surfaces, unless otherwise permitted by the manufacturers' printed instructions as approved by the Architect/Engineer.
 2. Applications may be continued during inclement weather only within the temperature limits specified by the paint manufacturer as being suitable of use during application and drying periods.

1.6 EXTRA STOCK

- A. Upon completion of the work of this Section, deliver to the Owner an extra stock equaling one (1) gallon of each color, type, and gloss of paint used in the Work, tightly sealing each container, and clearly labeling with contents and location where used.

PART 2 - PRODUCTS

2.1 PAINT MATERIALS

- A. Acceptable materials:
 - 1. The Painting Schedule in Part 3 of this Section is based on products of the Sherwin Williams Company.
 - 2. Equal products of Benjamin Moore, Dunn-Edwards, Deer-O, or Pittsburgh Paints. Stains as manufactured by Olympic, U.S. Plywood and Woodlife, or other manufacturers approved in advance by the Architect/Engineer, may be substitute in accordance with provisions of the Contract.
 - 3. Where products are proposed other than those specified by name and number in the Painting Schedule, provide under the products data submittal required by Article 1.3 of this Section a new painting schedule compiled in the same format used for the Painting Schedule included in this Section.
- B. Undercoats and thinners:
 - 1. Provide undercoat paint produced by the same manufacturer as the finish coat.
 - 2. Use only the thinners recommended by the paint manufacturer, and use only to the recommended limits.
 - 3. Insofar as practicable, use undercoat, finish coat, and thinner material as parts of a unified systems of paint finish.

2.2 COLOR SCHEDULES

- A. The Architect/Engineer will prepare a color schedule with samples for guidance in painting. The base color shall be white to match existing.
- B. The Architect/Engineer may select, allocate, and vary colors on different surfaces throughout the Work, subject to the following:
 - 1. Exterior and interior work: A maximum of six different colors may be used, with variations for trim, doors, miscellaneous work, and metal work.

2.3 APPLICATION EQUIPMENT

- A. For application of the approved paint, use only such equipment as is recommended for application of the particular paint by the manufacturer of the particular paint, and as approved by the Architect/Engineer.
- B. Prior to use of application equipment, verify that the proposed equipment is actually compatible with the material to be applied, and that integrity of the finish will not be jeopardized by use of the proposed equipment.

2.4 OTHER MATERIALS

- A. Provide other materials, not specifically described but required for a complete and proper installation, as selected by the Contractor subject to the approval of the Architect/Engineer.

PART 3 - EXECUTION

3.1 SURFACE CONDITIONS

- A. Examine the areas and conditions under which work of this Section will be performed. Correct conditions detrimental to timely and proper completion of the Work. Do not proceed until satisfactory conditions are corrected.
- B. In place test panels of all coatings and colors applied to each different building material will be required for Architect/Engineer approval.

3.2 MATERIALS PREPARATION

- A. General:
 - 1. Mix and prepare paint materials in strict accordance with the manufacturers' recommendations as approved by the Architect/Engineer.
 - 2. When materials are not in use, store in tightly covered containers.
 - 3. Maintain containers used in storage, mixing, and application of paint in a clean condition, free from foreign materials and residue.
- B. Stirring:
 - 1. Stir materials before application, producing a mixture of uniform density.
 - 2. Do not stir into the material any film which may form on the surface, but remove the film and, if necessary, strain the material before using.

3.3 SURFACE PREPARATION

- A. General:
 - 1. Perform preparation and cleaning procedures in strict accordance with the paint manufacturers' recommendations as approved by the Architect/Engineer.
 - 2. Remove removable items which are in place and are not scheduled to receive paint finish; or provide surface applied protection prior to surface preparation and painting operations.
 - 3. Following completion of painting in each space or area, reinstall the removed items by using workmen who are skilled in the necessary trades.
 - 4. Clean each surface to be painted prior to applying paint of surface treatment.
 - 5. Remove oil and grease with clean cloths and cleaning solvent of low toxicity and flash point in excess of 200 degrees F, prior to start of mechanical cleaning.
 - 6. Schedule the cleaning and painting so that dust and other contaminants from the cleaning process will not fall onto wet newly painted surfaces.
 - 7. Mask as required, lay drop cloths, and generally protect all adjacent surfaces. Properly protect or remove light fixtures, hardware, etc. during painting.
- B. Preparation of metal surfaces:

1. Thoroughly clean surfaces until free from dirt, oil, rust, scale and grease. Remove rust by scraping or sanding.
2. On galvanized surfaces, use solvent for the initial cleaning, and then treat the surface thoroughly with phosphoric acid etch. Remove etching solution completely before proceeding.
3. Allow to dry thoroughly before application of paint.
4. Prime all non-galvanized metal with a zinc based primer.

3.4 PAINT APPLICATION

A. General:

1. Touch up shop-applied prime coats which have been damaged, and touch up bare areas prior to start of finish coats application.
2. Slightly vary the color of succeeding coats.
 - a. Do not apply additional coats until the completed coat has been inspected and approved.
 - b. Only the inspected and approved coats of paint will be considered in determining the number of coats applied.
3. Sand and dust between coats to remove defects visible to the unaided eye from a distance of five feet.
4. All workmanship shall be of a professional quality with paint spread evenly without runs. Colors shall be selected by the Architect/Engineer, and shall conform to the approved sample.

B. Drying:

1. Allow sufficient drying time between coats, modifying the period as recommended by the material manufacturer to suit adverse weather conditions. Enamels, varnishes and exterior oil paints shall be allowed to dry at least 48 hours between coats. Interior paints shall be allowed to dry at least 24 hours between coats.
2. Consider oil-base and oleo-resinous solvent-type paint as dry for recoating when the paint feels firm, does not cause lifting or loss of adhesion of the undercoat.

C. Brush applications:

1. Brush out and work the brush coats onto the surface in an even film.
2. Cloudiness, spotting, holidays, laps, brush marks, runs, sags, ropiness, and other surface imperfections will not be acceptable.

D. Spray application:

1. Except as specifically otherwise approved by the Architect/Engineer, confine spray application to metal framework and similar surfaces where hand brush work would be inferior.
2. Where spray application is used, apply each coat to provide the hiding equivalent of brush coats.
3. Do not double back with spray equipment to build up film thickness of two coats in one pass.

- E. For completed work, match the approved Samples as to texture, color, and coverage. Remove, refinish, or repaint work not in compliance with the specified requirements.

3.5 PAINTING SCHEDULE

Provide the following paint finishes as scheduled on the Drawings. See paragraph 2.2, this Section, for color schedule. Materials for painting and finishing are based on the products of the Sherwin Williams Co.

A. INTERIOR SURFACES (NORMAL EXPOSURE)

1. CEMENT - Walls & Ceilings, Poured Concrete

- a. Latex Systems
 - 1. Eg-Shel / Satin Finish
 - 1st Coat: S-W PrepRite Masonry Primer, B28W300
(7 mils wet, 3 mils dry)
 - 2nd Coat: S-W ProMar 200 Latex Eg-Shel Enamel,
B20W200 Series
 - 3rd Coat: S-W ProMar 200 Latex Eg-Shel Enamel,
B20W200 Series
(4 mils wet, 1.3 mils dry per coat)
 - 2. Flat Finish
 - 1st Coat: S-W PrepRite Masonry Primer, B28W300
(7 mils wet, 3 mils dry)
 - 2nd Coat: S-W ProMar 200 Latex Flat Wall Paint,
B30W200 Series
 - 3rd Coat: S-W ProMar 200 Latex, Flat Wall Paint,
B30W200 Series
(4 mils wet, 1.4 mils dry per coat)
- 2. METAL - (Structural Steel Columns, Joists, Trusses, Beams, Miscellaneous & Ornamental Iron, Structural Iron, Ferrous Metal)
 - a. Latex Systems
 - 1. Eg-Shel / Satin Finish
 - 1st Coat: S-W All Surface Enamel Latex Primer, A41W210
(4 mils wet, 1.6 mils dry)
 - 2nd Coat: S-W ProMar 200 Latex Eg-Shel, B20W200 Series
 - 3rd Coat: S-W ProMar 200 Latex Eg-Shel, B20W200 Series
(4 mils wet, 1.5 mils dry per coat)
 - 2. Flat Finish
 - 1st Coat: S-W All Surface Enamel Latex Primer, A41W210
(4 mils wet, 1.6 mils dry)
 - 2nd Coat: S-W ProMar 200 Latex Flat, B30W200 Series
 - 3rd Coat: S-W ProMar 200 Latex Flat, B30W200 Series
(4 mils wet, 1.4 mils dry)
- 3. PLASTER - (Walls, Ceilings, Dadoes)
 - a. Latex Systems
 - 1. Semi-Gloss Finish
 - 1st Coat: S-W PrepRite Masonry Primer, B28W300
(7 mils wet, 3 mils dry)
 - 2nd Coat: S-W ProMar 200 Latex Semi-Gloss, B31W200 Series
 - 3rd Coat: S-W ProMar 200 Latex Semi-Gloss, B31W200 Series
(4 mils wet, 1.3 mils dry per coat)
 - 2. Eg-Shel / Satin Finish
 - 1st Coat: S-W PrepRite Masonry Primer B28W300
(7 mils wet, 3 mils dry)
 - 2nd Coat: S-W ProMar 200 Latex Eg-Shel, B20W200 Series
 - 3rd Coat: S-W ProMar 200 Latex Eg-Shel, B20W200 Series
(4 mils wet, 1.5 mils dry per coat)

B. EXTERIOR SURFACES (NORMAL EXPOSURE)

1. CEMENT - (Stucco, and Poured-in-place Cement)

a. Latex Systems

1. Satin Finish

1st Coat: S-W Loxon Exterior Acrylic Masonry Primer,
A24W300 (8 mils wet, 3.1 mils dry)

2nd Coat: S-W A-100 Exterior Latex Satin, A82 Series

3rd Coat: S-W A-100 Exterior Latex Satin, A82 Series
(4 mils wet, 1.4 mils dry per coat)

2. Flat Finish

1st Coat: S-W Loxon Exterior Acrylic Masonry Primer, A24W300 (8 mils wet, 3.1 mils
dry)

2nd Coat: S-W A-100 Exterior Latex Flat, A6 Series

3rd Coat: S-W A-100 Exterior Latex Flat, A6 Series
(4 mils wet, 1.4 mils dry per coat)

2. MASONRY - (Concrete Masonry Units [CMU] - Cinder or Concrete Block)

a. Latex Systems

1. Satin Finish

1st Coat: S-W Prep-Rite Block Filler, B25W25
(75 - 125 sq. ft./gal.)

2nd Coat: S-W A-100 Exterior Latex Satin, A82 Series

3rd Coat: S-W A-100 Exterior Latex Satin, A82 Series
(4 mils wet, 1.4 mils dry per coat)

2. Flat Finish

1st Coat: S-W Prep-Rite Block Filler, B25W25
(75 - 125 sq. ft./gal.)

2nd Coat: S-W A-100 Exterior Latex Flat, A6 Series

3rd Coat: S-W A-100 Exterior Latex Flat, A6 Series
(4 mils wet, 1.4 mils dry per coat)

3. METAL (Misc. Iron, Ornamental Iron, Handrails, Ladders, Fences)

a. Alkyd Systems

1. Gloss Finish

1st Coat: S-W All Surface Enamel Primer, A11W210
(4 mils wet, 2.4 mils dry)

2nd Coat: S-W All Surface Enamel, A11 Series

3rd Coat: S-W All Surface Enamel, A11 Series
(4 mils wet, 2.4 mils dry per coat)

2. Semi-Gloss Finish

1st Coat: S-W Metalastic DTM Acrylic Enamel B55Z600 Series

2nd Coat: S-W Metalastic DTM Acrylic Enamel B55Z600 Series
(3-5 mils dry per coat)

b. Urethane Systems

1. Gloss Finish

1st Coat: S-W Kem Bond HS Universal Metal Primer, B50Z Series
(8 mils wet, 5 mils dry)

2nd Coat: S-W Hi-Solids Polyurethane, B65-300 Series

3rd Coat: S-W Hi-Solids Polyurethane, B65-300 Series

- (3-4 mils dry per coat)
2. Satin Finish
 - 1st Coat: S-W Kem Bond HS Universal Metal Primer, B50Z Series
(8 mils wet, 5 mils dry)
 - 2nd Coat: S-W Corothane II Satin Polyurethane, B65-200 Series
 - 3rd Coat: S-W Corothane II Satin Polyurethane, B65-200 Series
(2-4 mils dry per coat)
4. METAL - (Structural Iron & Steel, Sashes, Trim, Conductors, Doors, Ducts, Vents)
- a. Alkyd Systems
 1. Gloss Finish
 - 1st Coat: S-W Kem Bond HS Universal Metal Primer, B50Z Series (8 mils wet, 5 mils dry)
 - 2nd Coat: S-W Industrial Enamel, HS B54Z400 Series
 - 3rd Coat: S-W Industrial Enamel, HS B54Z400 Series
(2 - 4 mils dry per coat)
 2. Semi-Gloss Finish
 - 1st Coat: S-W Metalastic DTM Acrylic Enamel B55Z600 Series
 - 2nd Coat: S-W Metalastic DTM Acrylic Enamel B55Z600 Series
(3-5 mils dry per coat)
 3. Flat Finish
 - 1st Coat: S-W Kem Bond HS Universal Metal Primer, B50Z Series (8 mils wet, 5 mils dry)
 - 2nd Coat: S-W ProMar Alkyd Flat Exterior, B38 Series
 - 3rd Coat: S-W ProMar Alkyd Flat Exterior, B38 Series
(4 mils wet, 2 mils dry per coat)
 - b. Urethane Systems
 1. Gloss Finish
 - 1st Coat: S-W Kem Bond HS Universal Metal Primer, B50Z Series (8 mils wet, 5 mils dry)
 - 2nd Coat: S-W Hi-Solids Polyurethane, B65-300 Series
 - 3rd Coat: S-W Hi-Solids Polyurethane, B65-300 Series
(3-4 mils dry per coat)
 2. Satin Finish
 - 1st Coat: S-W Kem Bond HS Universal Metal Primer, B50Z Series (8 mils wet, 5 mils dry)
 - 2nd Coat: S-W Corothane II Satin Polyurethane, B65-200 Series
 - 3rd Coat: S-W Corothane II Satin Polyurethane, B65-200 Series
(2-4 mils dry per coat)
5. WOOD - (Trim, Doors, Misc. Wood)
- a. Latex Systems
 1. Semi-Gloss Finish
 - 1st Coat: S-W A-100 Exterior Latex Wood Primer, B42W41
(4 mils wet, 1.4 mils dry)
 - (If Tannin Bleeding occurs, use A-100 Exterior Oil Wood Primer, Y24W20)
 - 2nd Coat: S-W DTM Acrylic Semi-Gloss Coating, B66-200 Series
 - 3rd Coat: S-W DTM Acrylic Semi-Gloss Coating, B66-200 Series (2 - 4 mils dry per coat)
 2. Satin Finish
 - 1st Coat: S-W A-100 Exterior Latex Wood Primer, B42W41
(4 mils wet, 1.4 mils dry)
 - (If Tannin Bleeding occurs, use A-100 Exterior Oil Wood Primer, Y24W20)
 - 2nd Coat: S-W A-100 Exterior Latex Satin, A82 Series
 - 3rd Coat: S-W A-100 Exterior Latex Satin, A82 Series

(4 mils wet, 1.4 mils dry per coat)

3. Flat Finish

1st Coat: S-W A-100 Exterior Latex Wood Primer, B42W41

(4 mils wet, 1.4 mils dry)

(If Tannin Bleeding occurs, use A-100 Exterior Oil Wood Primer, Y24W20)

2nd Coat: S-W A-100 Exterior Latex Flat, A6 Series

3rd Coat: S-W A-100 Exterior Latex Flat, A6 Series

(4 mils wet, 1.4 mils dry per coat)

END OF SECTION

SECTION 16010
BASIC ELECTRICAL GENERAL REQUIREMENTS

PART 1 GENERAL

1.01 This section is supported by the requirements of all other Contract Documents.

1.02 SUMMARY

- A. This Section governs general procedures and work applicable to Divisions 15 and 16 and to certain equipment and work in Divisions 2, 8, 10, 11, 14, 15 and 16.
1. Furnish labor, supervision, energy, materials, tools, transportation, equipment, permits (if required), insurance, taxes, temporary protection and correction necessary to provide work shown and specified.
 2. Provide apparatus, appliances, material or work not shown on drawings but mentioned in specifications, or vice versa, and any incidental accessories necessary to make work complete and ready for operation or inspection by inspecting authorities, even if not specified, without additional expense to Owner.
 3. Include minor details not usually shown or specified, but necessary for proper installation and operation, the same as if specified. In cases where apparatus is referred to in singular numbers, it is intended that such reference include as many such items as are required to complete work.
 4. Provide conduit, wiring, and miscellaneous accessories necessary for complete installation of and final connections to equipment furnished by Owner, if any, and by other trades.

1.03 RELATED SECTIONS

1. Cutting and Patching.
2. Contract Closeout.
3. Flashing (except cap flashing for roof equipment and ducts).
4. Painting of exposed surfaces including color code painting of piping and conduit.
5. Access panels.
6. Motor power and control wiring.

1.04 WORK NOT INCLUDED

- A. Equipment and wiring provided by local Telephone utility and local Power and Light utility.

1.05 DRAWINGS

- A. Drawings are diagrammatic and indicate general arrangement of systems and work.
 - 1. Do not scale drawings.
 - 2. Consult architectural drawings, shop drawings and details for exact locations of fixtures, thermostats and equipment.
 - a. Where these are not definitely located, obtain this information from Project Architect/Engineer in writing prior to any rough-in.
- B. Follow drawings in laying out work.
 - 1. Check drawings of other trades to verify spaces in which work will be installed.
 - 2. Maintain maximum headroom clearances and space conditions at all points as required by local codes and regulations.
 - 3. Where headroom or space conditions appear inadequate, obtain instructions from Project Architect/Engineer before proceeding with installation.
- C. Make reasonable modifications, without extra charge to Owner, in layout as needed to prevent conflict with work of other trades or for proper execution of work.
- D. Engineering drawings are schematic for special equipment since exact dimensions and roughing-in requirements may vary with different manufacturers.

1.06 COOPERATION WITH OTHER TRADES

- A. Schedule work and provide temporary service and connections for other trades.
- B. Schedule work and provide temporary service and connections so existing systems will not be interrupted when they are required for usage of the existing building(s). Obtain written approval from the Owner at least 14 days prior to any interruption or connection.
- C. Perform work at such time and in such manner as to cause minimum inconvenience to the Owner and as approved by the Architect. No allowance will be made for lack of knowledge of existing conditions.
- D. Make all arrangements with the utility company for connecting the new services and providing all temporary services.
- E. Field painting of exposed conduit and hangers is specified in the Section entitled PAINTING. Clean all surfaces and hanger rods free of grease, scale, rust and other foreign matter ready for painting. Touch up all factory finished, marred in construction, with factory touch-up kits.
- F. Correct, without extra charge, electrical work installed in such a manner to cause

interference with work of other trades, or to cause unacceptable clearance problems.

1.07 SHOP DRAWINGS AND PRODUCT DATA

- A. Shop drawing requirements are specified in the General Conditions of the Contract for Construction.
 - 1. Do not ship apparatus or equipment from stock or fabricate until shop drawings have been accepted by Project Engineer.
 - 2. Submit shop drawings with pertinent data and with identification mark numbers specified or scheduled.
 - 3. Shop drawings without identifications mark numbers or with incomplete performance information will not be reviewed until submission is complete.
- B. Submit shop drawings, or product data where permitted, for the following:
 - 1. Shop drawings of panelboards, transformers, lighting fixtures, wiring and cable, raceways and wireways, outlet, pull and junction boxes, wiring devices, disconnect switches, fuses and circuit breakers, generator set, day-tank, automatic transfer switch(s) and fire alarm system.
 - 2. Catalog cuts without shop drawings are not acceptable.
 - 3. Submit 1/2" scale layout drawings for main electrical equipment spaces such as electrical rooms, closets, and major conduit bank runs. Submit layout drawings for review prior to installation of the work.

1.08 RECORD DRAWINGS

- A. Keep accurate notes on record drawings of work as actually installed from work as originally indicated, paying particular attention to dimensioning of outside underground lines, their offsets and box locations.

1.09 SUPERVISION

- A. Each subcontract trade shall provide services of an experienced superintendent, who shall be constantly in charge of installation of the work.

1.10 INSPECTIONS PRIOR TO OWNER'S ACCEPTANCE INSPECTION

- A. Arrange and schedule as many inspections of work as may be necessary and, when appropriate, notify Project Architect/ Engineer, in writing, that safety-to-life systems are functioning in accordance with specifications.

1.11 CERTIFICATES

- A. On completion of work, obtain certificates, if required, of compliance, approval or acceptance from authorities having jurisdiction over work and deliver these certificates to Project Architect.

1.12 MANUFACTURER'S NAMEPLATES

- A. Each major component of equipment shall have manufacturer's name, address, model number and rating on a plate securely affixed in a conspicuous place.
- B. Nameplate of a distributing agent will not be acceptable.

1.13 ACCEPTANCE

- A. Operation of mechanical and electrical work by Contractor does not constitute acceptance of work. Acceptance will occur after Contractor has adjusted equipment, demonstrated that it fulfills requirements of specifications and drawings, corrected defects, and has furnished all of required certificates, if any.

1.14 SPECIAL WARRANTIES

- A. **Manufacturer's Equipment and System Warranties:** Provide manufacturer's written warranties which become a part of Contractor's responsibility to Owner in accordance with General Conditions of the Contract for Construction.
- B. **Manufacturer's Service:** Provide manufacturer's service agreements, where required elsewhere in Sections of these specifications.
- C. **Contractor's Corrections of Work:**
 - 1. In addition to foregoing special warranties, any warranties made by Subcontractors to the Contractor are a part of the Contractor's responsibility to the Owner in accordance with General Conditions of the Contract.
 - 2. Correction of work shall include shipping, labor, supervision and related work involved in replacing defective parts or materials provide by manufacturer's under their warranties.

1.15 PRODUCT DELIVERY, STORAGE AND HANDLING

- A. Deliver products to job site in manufacturer's original unopened crates or containers, clearly labeled with manufacturer's name, product number and brand. Repair damage sustained by product(s) in transit and handling. If damage sustained while transporting products to job site is unrepairable, replace the product(s) at no cost to Owner.
- B. Store and protect materials and equipment to prevent damage of any kind. Keep products dry at all times. Protect exposed metal surfaces with a light oil or silicone coating to prevent rust while in storage.
- C. Handle products in such a manner to prevent breakage of containers and damage of any kind.
- D. Schedule delivery of materials to job site in accordance with requirements of job progress to avoid delaying work.

PART 2 PRODUCTS

2.01 MATERIALS AND EQUIPMENT

- A. Materials and equivalent required for work shall be new, of good quality, furnished, delivered, erected, connected and finished in every detail, selected and arranged to fit properly into building spaces. Where no specific kind or quality of material is given, provide a good quality standard article as accepted by Project Architect/Engineer.
- B. Equipment shall be of type and capacity shown on equipment schedules on drawings and in specifications and shall be as manufactured by one of manufacturers designated or equivalent, accepted in advance by Project Architect/Engineer.
- C. For ease of maintenance and parts replacement, use equipment from a single manufacturer to maximum extent possible.
- D. Equipment, materials and components shall be new, standard current products of manufacturers regularly engaged in production of such equipment and shall be manufacturer's latest design conforming to specifications. Materials shall be accepted by code enforcing authorities. Materials used in fire rated construction and in electrical work shall be UL listed, with UL labels as specified.
- E. Hardware and accessory fitting shall be U.S. Standard sizes designed, intended or appropriate for the use, and complimenting items with which they are used. Furnish with corrosion protection suitable for the atmosphere in which they are installed.
- F. Conform to Requirements of General Conditions of the Contract for Construction for coordinating space requirements, mounting arrangement(s) and service connections when substitute equipment is furnished instead of that used as a basis for design. Ascertain before ordering that equipment will fit assigned space and that it can be moved into position without interference from other construction, i.e., check door clearances, ceiling heights, crane access and the like. Be responsible for expenses generated by substitution of equipment used as a basis for design. Maintain clearances as required by the N.E.C.

2.02 IDENTIFICATION OF ELECTRICAL SYSTEM ITEMS

- A. Identify electrical equipment and conductors in accordance with following:
 - 1. Distribution Equipment: Major components of distribution system such as circuit breakers, switches, panelboards shall have nameplates with equipment identification, voltage and phase ratings and source of feed or circuit utilization. Equipment identification shall correspond to the designation on single line diagram. Panelboards shall have typed directories.
 - 2. Starters, Disconnect Switches and Controls: Provide laminated phenolic nameplates with white letters on a black field secured with flush fastenings identifying equipment served.
 - 3. Conductors: Color code wire and cable for feeders and branch circuits as follows unless otherwise required by local codes or electric utility company.

PHASE
A

208Y/120V
Black

B	Red
C	Blue
Neutral	White
Ground	Green

4. Ground Fault Protected Devices:

- a. Identify devices protected by ground fault interrupters.
- b. Receptacles, not otherwise identified by manufacturer, shall have cover plates with words "Protected by GFI" and "Test Before Using" engraved thereon.

2.03 UNDERWRITERS' LABORATORIES LISTING AND LABELS

- A. Where materials and equipment are available under continuing inspection and labeling of UL, provide such material and equipment.
- B. Listing by Underwriters' Laboratories shall be evidenced by label or:

UL - Electrical Construction Materials List (Green Book).
UL - Electrical Appliance and Utilization Equipment List.
UL - Building Materials List.

PART 3 EXECUTION

3.01 INSPECTION

- A. Verify/examine that the surfaces, substrates, and conditions are satisfactory to receive electrical general provisions, and are free from deviations/defects affecting quality of the work.
- B. Notify Contractor in writing of conditions detrimental to proper/timely completion of the work.
- C. Do not proceed with work until unsatisfactory conditions have been corrected in a manner acceptable to installer.
- D. Beginning of installation will be construed as acceptance of existing substrates, surfaces, and conditions.

3.02 EQUIPMENT INSTALLATION

- A. Obtain services of manufacturer's representatives of major electrical equipment at job site during erection or construction of their equipment to insure proper installation. Failure to have such checks made by manufacturers shall place full responsibility for proper installation on Contractor who shall make any corrections or remedy defects at no additional cost to Owner.
- B. Where necessary to meet space conditions bring equipment to its ultimate location in pieces or otherwise disassembled, then assemble it in place. Provide flanges, studs and the like for matching, alignment and field assembly.

- C. Conduct field tests of equipment after assembly and during under direct supervision of manufacturer's representative. Upon satisfactory conclusion of field tests, manufacturer shall furnish, for each such apparatus or equipment, a written statement certifying that there has been no invalidation of any warranties or guaranties, nor impairment of capacity or functioning of apparatus or equipment. Field tests shall be in addition to all factory tests, shop tests and final tests and adjustments.
- D. Avoid field assembly wherever possible by suitable scheduling of the general construction work.
 - 1. Extra compensation will not be allowed for those cases where it is necessary to field assemble equipment or apparatus.

3.03 FABRICATION AND INSTALLATION

- A. Workers: Use thoroughly trained and experienced workers, completely familiar with items to be installed and manufacturer's current recommended methods of installations.
- B. Set equipment level, properly aligned and bolted together where in sections. Secure equipment and materials firmly in place. Screws, bolts, nuts, clamps, fittings or other fastening devices shall be made up tight.
- C. Repair to a new condition, or replace materials damaged during delivery, storage or installation. Touch-up scratched or marred finishes on equipment to match original finish or completely refinish.
- D. Factory paint or finish enclosures, panels, cabinets, relays, safety switches, fixtures and other exposed equipment or accessories except as indicated otherwise. Group mounted items shall be similar in finish and color.
- E. Make connections for air conditioning and ventilating equipment and controls. Follow manufacturers recommendations and system requirements when no other information available.
- F. Support electrical raceways, conduits and light fixtures from overhead structure, not from ducts, pipes, conduits or the like. Support piping and HVAC ducts from overhead structure, not from ducts, pipes, conduits or equipment.
- G. In order to use same means of support for electrical and mechanical items, design combined support system and coordinate to safely support suspended items.

3.04 HOUSEKEEPING

- A. Clean exposed surfaces raceways and equipment which have become covered with dirt, plaster or other material during handling and construction before such surfaces are prepared for painting or enclosed within building structure,
- B. Keep raceway openings closed by means of plugs or caps to prevent entrance of foreign matter.
 - 1. Cover fixtures, equipment and apparatus to protect them against dirt, water,

chemical or mechanical damage both before and after installation.

2. Damaged fixtures, equipment or apparatus shall be restored to its original condition or replaced at no cost to Owner.

3.05 EXCAVATION AND BACKFILLING

- A. Excavation, backfilling and compaction of trenches required for the installation of electrical services and to points of connection with exterior underground utilities outside of the building shall be performed as specified in Trenching, Backfilling and Compaction for Utilities - Refer to Division 2 sections.

3.06 SLEEVES BLOCKOUTS, CUTTING AND PATCHING, CORING AND DRILLING

A. Sleeves:

1. All conduits passing through concrete slabs shall be provided with sleeves.
2. All conduits passing through interior concrete or masonry walls and partitions shall be provided with sleeves.
3. Where pipe motion due to expansion and contraction will occur, sleeves shall be of sufficient diameter to permit free movement of pipe.

B. Cutting and Patching:

1. Cut and patch as needed for installation of electrical equipment. Perform finish patching according to specifications for each finish, by mechanics skilled in each type finish.
2. Install work so that no undue cutting and patching will be required in building construction. Do no cutting that may impair strength of building construction. Install work in various portions of building as construction progresses. Do not delay construction of building.
3. Cut and patch as needed for conduits where sleeves and inserts were not installed, or where incorrectly located.
4. Provide for cutting out holes in structural steel webs (number, size and location) by means of shop drawing submittal and review only as approved by Project Architect/Engineer. Reinforce holes as directed by Project Architect/Engineer.

C. Coring and Drilling:

1. If a sleeve is omitted, core drill to permit insertion of a pipe sleeve with sufficient clearance to permit grouting in place with specified backer rod and sealant space between the line and sleeve.
2. When core drilling or cutting duct holes in foundations, walls, beams, columns or structural slabs, determine the location of reinforcement and tendons before coring.

3. Holes, except for small screws, may not be drilled in beams or other structural members, without obtaining prior acceptance of Project Architect/Engineer.

3.07 WATERPROOFING AND ROOFING

- A. Where electrical work penetrates building envelope, or any waterproofed construction, method of installation shall be performed in a manner to prevent transmission of water, heat, cold and drafts.
- B. Follow details, including architectural, which establish types of waterproofing construction for each penetration condition.
- C. Where a detail suitable to encountered condition is lacking, request instructions from Project Architect/Engineer.
- D. Provide necessary sleeves, sealing and flashing required to make opening watertight

3.08 FINAL TESTING, ADJUSTMENTS AND ACCEPTANCE OF ELECTRICAL EQUIPMENT AND SYSTEMS

- A. Schedule testing and cleared through Project Architect/Engineer.
 1. No testing of any kind shall be done or scheduled without clearance by Project Architect/Engineer.
 2. Furnish Project Architect/Engineer with name of person who will be in charge of testing, energizing and start-up.
 3. Confer with Project Architect/Engineer on procedures to be followed in obtaining clearances for electrical equipment.
 4. Procedures as finally agreed upon shall be adhered to.
- B. Complete test and inspection records shall be made and incorporated into a report for each piece of equipment tested. Record readings taken. Submit four copies to Project Architect for review.
- C. Notify Project Architect in writing at least one week prior to test, establishing time that test is to be performed.
 1. Perform tests in presence of Project Architect/Engineer.
- D. Furnish necessary meters, instruments, temporary wiring and labor to perform required tests and adjustments of equipment and wiring including electrical equipment furnished by others, to determine proper polarity, phasing, freedom from grounds and shorts and operation of equipment. Measuring instruments shall be properly calibrated.
- E. Demonstrate materials and manner of installation to be in accordance with the requirements of state and local public authorities, the utility company and NFPA.

- F. Energize equipment following established procedures after certification by the Contractor that the installation is satisfactory.
- G. Wiring:
1. Check system and equipment grounds for resistance using the Megger ground tester in accordance with manufacturer's instructions. Investigate circuits showing insulation resistance less than minimum values given in N.E.C. Correct weak points.
 2. Overall resistance of the ground system shall be no greater than 25 ohms. Inspect grounding system to insure that above-ground cables and connections are suitably protected. Provide additional ground rod, if needed, to obtain the specified resistance.
 3. Make ground resistance tests at test points designated by the Project Architect/Engineer. Make ground resistance tests in accordance with James G. Biddle Company Bulletins 25T2 and 25-J.
 4. Correct or replace nominal current-carrying circuits which are defective or grounded. Correct other troubles encountered in these tests.
- H. Breakers: Set breakers so equipment will be in proper operating condition before being placed in service. Perform final operational tests to determine that wiring connections are correct.
- I. Lighting:
1. Check lighting fixtures and receptacles for proper operation. At completion of work, clean fixtures and lenses and replace missing and burned out lamps.
 2. In residential projects, provide keyless lamp holders and bulbs to all lighting outlets for future tenant luminaires, in order to comply with inspecting authority requirements.
- J. Motors:
1. Make these tests on motors before start-up: Check motor nameplates for HP, speed, phase and voltage. Check bearings to see if they are filled with oil or grease. Lubricate. Check coupling alignment and shaft end-play.
 2. Make these tests on motors during start-up:
 - a. Check shaft rotation before final connections are made. Check for bearing temperature and smooth operation.
 - b. Take a current reading at full load using a clamp-on ammeter. If ammeter is over the rated full load current, determine reason for the discrepancy and take corrective action.
 3. After all connections are made, test motors and equipment for proper operation. Investigate cause of any motor operating above full load rating

and remove cause, or report to Project Architect/Engineer instead of increasing overload heater rating. Check rotation of motors.

4. Check overload elements in motor starters for suitability to the motor characteristics. Replace any overload element that does not conform to starter manufacturer's recommendations based on actual nameplate current rating of the motor. Investigate the cause of any motor operating above full load rating and correct. Under no circumstances shall oversize overload relay trip rating be substituted.
- K. Transformers: Megger winding insulation resistance, primary and secondary-to-ground and primary-to-secondary. Windings shall exhibit resistance in megohms equal to eight times the voltage rating of the winding in kV.
- L. Control and Alarms: Check control and alarm circuits for proper operation. Test switchgear, switchboards, fire alarm system, as specified in each Section.
- M. Service Voltage: Check service voltage at no-load and at full load on the distribution system. The objective shall be to maintain the equipment terminal voltage at less than 10% above nameplate rating at full system load. Then set transformer no-load taps so that at normal loading the average operating voltages at the terminals of all utilization equipment matches the nameplate voltage of that equipment as closely as possible.
- N. Test all circuits, which under any circumstances can be paralleled, for proper phasing using hot phasing.
- O. Acceptance: Observation of the operation of the electrical installation and equipment by the Project Architect/Engineer does not constitute acceptance of the Work. Acceptance will be made after the Contractor has adjusted his equipment, demonstrated that it meets the requirements of the Contract Document, and has furnished all the required certificates.

3.10 TOOLS AND SPARE PARTS

- A. Use only tools designed for each operation. Keep tools in good condition. Do not use worn or broken tools. Wrench and vise teeth shall be sharp and clean to prevent damage to the materials. Screw drivers and wrenches shall be of the proper size to prevent damage to head or nuts.
- B. Deliver special tools and spare parts provided with equipment to an authorized representative of the Owner. Obtain signed and dated receipts.

3.11 DEMONSTRATION

- A. Demonstrate the essential features of the following mechanical and electrical systems upon completion of satisfactory testing:
 1. Power System.
 2. Lighting System.
 3. Fire Alarm System.

4. Emergency Generator.
 - B. Hold the demonstrations in the presence of the Owner or his designated representatives and the Project Architect/Engineer to show functions, locations and relationships to the Drawings. Demonstrate how to "start-stop", reset, replace, and emergency procedures. Demonstrate one system at a time.

END of SECTION

PART 7

Historic Architectural Review Commission (HARC)



City of Key West
Planning Department
1300 White Street
Key West, Florida 33040

September 22, 2020

Arch. Bert Bender
Bender & Associates
410 Angela Street
Key West, Florida 33040

**RE: STABILIZATION AND MAINTENANCE OF EAST AND WEST HISTORIC
CABLE HUTS. REMOVAL OF NON-HISTORIC ELEMENTS FROM WEST
CABLE HUT.
FOR: #1 MALLORY SQUARE - HARC APPLICATION # H2020-0023
KEY WEST HISTORIC DISTRICT**

Dear Architect Bender:

This letter is to notify you that the Key West Historic Architectural Review Commission **approved** the above-mentioned project on the public hearing held on Tuesday, August 25, 2020. The Commissioners made their motions based on the submitted documents.

You may now apply for the necessary permits and required approvals. Should you have any questions, please do not hesitate to contact me at your convenience.

On behalf of the Historic Architectural Review Commission of our City, thank you for your interest in the preservation of Key West's historic heritage.

Sincerely:

Enid Torregrosa-Silva MSHP
Historic Preservation Planner
City of Key West
1300 White Street
Key West, Florida 33040

305.809.3973

etorregrosa@cityofkeywest-fl.gov

Copy. Steven P. McAlearney

HARC MAJOR PROJECTS CERTIFICATE OF APPROPRIATENESS

\$400 NON-REFUNDABLE BASE APPLICATION FEE - OTHER FEES MAY BE APPLICABLE



City of Key West

1300 WHITE STREET
KEY WEST, FLORIDA 33040

HARC COA # <i>2020-0023</i>	REVISION #	INITIAL & DATE
FLOOD ZONE	ZONING DISTRICT	BLDG PERMIT #

A PRE-APPLICATION MEETING WITH HARC STAFF IS REQUIRED PRIOR TO SUBMITTAL

ADDRESS OF PROPOSED PROJECT:	Wall Street, Mallory Square Cable Huts		
NAME ON DEED:	City of Key West	PHONE NUMBER	305-809-3963
OWNER'S MAILING ADDRESS:	1300 White Street	EMAIL	karen.wilman@cityofkeywest-fl.gov
	Key West, FL 33040		
APPLICANT NAME:	Karen Wilman	PHONE NUMBER	305-809-3963
APPLICANT'S ADDRESS:			
APPLICANT'S SIGNATURE:	<i>[Handwritten Signature]</i>		DATE July 23, 2020

ANY PERSON THAT MAKES CHANGES TO AN APPROVED CERTIFICATE OF APPROPRIATENESS MUST SUBMIT A NEW APPLICATION.

FLORIDA STATUTE 837.06: WHOEVER KNOWINGLY MAKES A FALSE STATEMENT IN WRITING AND WITH THE INTENT TO MISLEAD A PUBLIC SERVANT IN THE PERFORMANCE OF HIS OR HER OFFICIAL DUTY SHALL BE GUILTY OF A MISDEMEANOR OF THE SECOND DEGREE PUNISHABLE PER SECTION 775.082 OR 775.083. THE APPLICANT FURTHER HEREBY ACKNOWLEDGES THAT THE SCOPE OF WORK AS DESCRIBED IN THE APPLICATION SHALL BE THE SCOPE OF WORK THAT IS CONTEMPLATED BY THE APPLICANT AND THE CITY. THE APPLICANT FURTHER STIPULATES THAT SHOULD FURTHER ACTION BE TAKEN BY THE CITY FOR EXCEEDING THE SCOPE OF THE DESCRIPTION OF WORK, AS DESCRIBED HEREIN, AND IF THERE IS CONFLICTING INFORMATION BETWEEN THE DESCRIPTION OF WORK AND THE SUBMITTED PLANS, THE AFOREMENTIONED DESCRIPTION OF WORK SHALL BE CONTROLLING.

PROJECT INCLUDES: REPLACEMENT OF WINDOWS RELOCATION OF A STRUCTURE ELEVATION OF A STRUCTURE

PROJECT INVOLVES A CONTRIBUTING STRUCTURE: YES NO INVOLVES A HISTORIC STRUCTURE: YES NO

PROJECT INVOLVES A STRUCTURE THAT IS INDIVIDUALLY LISTED ON THE NATIONAL REGISTER: YES NO

DETAILED PROJECT DESCRIPTION INCLUDING MATERIALS, HEIGHT, DIMENSIONS, SQUARE FOOTAGE, LOCATION, ETC.	
GENERAL:	The scope of work includes stabilization of the structures and general maintenance of the the buildings.
MAIN BUILDING:	Stabilize and repair existing concrete walls. West hut will require the removal of all non-historic roof elements, walls, and doors and will be repaired to match the East Hut. Paint concrete walls white to match the original design intent.
DEMOLITION (PLEASE FILL OUT AND ATTACH DEMOLITION APPENDIX):	

APPLICATIONS MUST BE SUBMITTED IN PERSON WITH HARD COPIES BY 3PM ON THE SCHEDULED DEADLINE
 PLEASE SEND AN ELECTRONIC COPY OF ALL DOCUMENTS TO HARC@CITYOFKEYWEST-FL.GOV

ACCESSORY STRUCTURE(S):	
PAVERS: No change at this time	FENCES: No Change at this time
DECKS: NA	PAINTING: Exterior concrete to be primed and painted.
SITE (INCLUDING GRADING, FILL, TREES, ETC): Maintenance of existing landscape.	POOLS (INCLUDING EQUIPMENT): NA
ACCESSORY EQUIPMENT (GAS, A/C, VENTS, ETC.): Existing kitchen exhaust to be removed from roof	OTHER:

OFFICIAL USE ONLY:		HARC COMMISSION REVIEW		EXPIRES ON:
MEETING DATE: <i>08/25/2020</i>	<input checked="" type="checkbox"/> APPROVED	<input type="checkbox"/> NOT APPROVED	<input type="checkbox"/> DEFERRED FOR FUTURE CONSIDERATION	INITIAL: <i>KA</i>
MEETING DATE:	<input type="checkbox"/> APPROVED	<input type="checkbox"/> NOT APPROVED	<input type="checkbox"/> DEFERRED FOR FUTURE CONSIDERATION	INITIAL:
MEETING DATE:	<input type="checkbox"/> APPROVED	<input type="checkbox"/> NOT APPROVED	<input type="checkbox"/> DEFERRED FOR FUTURE CONSIDERATION	INITIAL:
REASONS OR CONDITIONS:				
STAFF REVIEW COMMENTS:				
FIRST READING FOR DEMO:		SECOND READING FOR DEMO:		
HARC STAFF SIGNATURE AND DATE:		HARC CHAIRPERSON SIGNATURE AND DATE: <i>[Signature]</i> <i>08/27/2020</i>		

THIS APPLICATION MAY BE REVIEWED BY PLANNING DEPARTMENT STAFF.

HARC Certificate of Appropriateness: Demolition Appendix



City of Key West
 1300 WHITE STREET
 KEY WEST, FLORIDA 33040



HARC COA # 2020-0023	INITIAL & DATE
ZONING DISTRICT	BLDG PERMIT #

ADDRESS OF PROPOSED PROJECT:	Wall Street, Mallory Square Cable Huts
PROPERTY OWNER'S NAME:	City of Key West
APPLICANT NAME:	Karen Wilman

I hereby certify I am the owner of record and that the work shall conform to all applicable laws of this jurisdiction. By receiving a Certificate of Appropriateness, I realize that this project will require a Building Permit approval **PRIOR to proceeding with the work outlined above** and that a final inspection is required under this application. I also understand that **any changes to an approved Certificate of Appropriateness must be submitted for review.**

PROPERTY OWNER'S SIGNATURE	DATE AND PRINT NAME 8/14/2020

DETAILED PROJECT DESCRIPTION OF DEMOLITION
Stabilize and repair existing concrete walls. West hut will require the removal of all non- historic roof elements, walls, and doors.

CRITERIA FOR DEMOLITION OF CONTRIBUTING OR HISTORIC STRUCTURES:
Before any Certificate of Appropriateness may be issued for a demolition request, the Historic Architectural Review Commission must find that the following requirements are met (please review and comment on each criterion that applies);
(1) If the subject of the application is a contributing or historic building or structure, then it should not be demolished unless its condition is irrevocably compromised by extreme deterioration or it does not meet any of the following criteria:
(a) The existing condition of the building or structure is irrevocably compromised by extreme deterioration.
NA
(2) Or explain how the building or structure meets the criteria below:
(a) Embodies no distinctive characteristics of a type, period, or method of construction of aesthetic or historic significance in the city and is not a significant and distinguishable building entity whose components may lack individual distinction.

Nothing in this application is intended to alter the authority of the Building Official to condemn for demolition dangerous buildings, as provided in Section 102-218 of the Land Development Regulations and Chapter 14 of the Code of Ordinances.

(b) Is not specifically associated with events that have made a significant contribution to local, state, or national history.

(c) Has no significant character, interest, or value as part fo the development, heritage, or cultural characteristics of the city, state or nation, and is not associated with the life of a person significant in the past.

(d) Is not the site of a historic event with significant effect upon society.

(e) Does not exemplify the cultural, political, economic, social, or historic heritage of the city.

(f) Does not portray the environment in an era of history characterized by a distinctive architectural style.

(g) If a part of or related to a square, park, or other distinctive area, nevertheless should not be developed or preserved according to a plan based on the area's historic, cultural, natural, or architectural motif.

(h) Does not have a unique location or singular physical characteristic which represents an established and familiar visual feature of its neighborhood or of the city, and does not exemplify the best remaining architectural type in a neighborhood.

Nothing in this application is intended to alter the authority of the Building Official to condemn for demolition dangerous buildings, as provided in Section 102-218 of the Land Development Regulations and Chapter 14 of the Code of Ordinances.

(i) Has not yielded, and is not likely to yield, information important in history.

CRITERIA FOR DEMOLITION OF NON-CONTRIBUTING OR NON-HISTORIC STRUCTURES:

The following criteria will also be reviewed by the Historic Architectural Review Commission for proposed demolitions. The Commission shall not issue a Certificate of Appropriateness that would result in the following conditions (please review and comment on each criterion that applies);

(1) Removing buildings or structures that are important in defining the overall historic character of a district or neighborhood so that the character is diminished. The project will be preserving the historic structures and removing the non-historic elements.

(2) Removing historic buildings or structures and thus destroying the historic relationship between buildings or structures and open space.

NA- no historic elements will be removed.

(3) Removing an historic building or structure in a complex; or removing a building facade; or removing a significant later addition that is important in defining the historic character of a site or the surrounding district or neighborhood.

Alterations are non-historic and the main structures will maintain the character and integrity.

(4) Removing buildings or structures that would otherwise qualify as contributing.

Non- Historic elements will not qualify in the near future as contributing .

HARC POSTING AFFIDAVIT

STATE OF FLORIDA:
COUNTY OF MONROE:

BEFORE ME, the undersigned authority, personally appeared Enid Torreirosa, who, first being duly sworn, on oath, depose and says that the following statements are true and correct to the best of his/her knowledge and belief:

1. That a legal notice for Public Notice of Hearing of the Historic Architectural Review Commission (HARC) was placed on the following address:
#1 Gallery Square i Wall Street on the 20 day of August, 2020.

This legal notice(s) contained an area of at least 8.5"x11".

The property was posted to notice a public hearing before the Key West Historic Architectural Review Commission to be held on August 27, 2020.

The legal notice(s) is/are clearly visible from the public street adjacent to the property.

The Certificate of Appropriateness number for this legal notice is 2020-0063

2. A photograph of that legal notice posted in the property is attached hereto.

Signed Name of Affiant:

[Signature]
Date: August 20, 2020
Address: 1300 White Street
City: Key West
State, Zip: Florida 33000

The forgoing instrument was acknowledged before me on this 20th day of August, 2020.

By (Print name of Affiant) Enid Torreirosa who is personally known to me or has produced _____ as identification and who did take an oath.

NOTARY PUBLIC

Sign Name: Margarita Pedroza
Print Name: Margarita Pedroza
Notary Public - State of Florida (seal)
My Commission Expires: 8/20/2023





Barracuda Builders of Key West, Inc.
5601 3rd Avenue, Key West, FL 33040
State of Florida License CGC1521253
Ofc: (305) 396-7752
Fax: (305) 396-7832

SCHEDULE OF VALUES

To: City of Key West

Date: October 28, 2020

Project: Cable Hut Stabilization and Repairs

ITEM	VALUE
General Conditions	\$61,030.00
Demolition	\$19,860.00
Excavation & Dewatering	\$89,885.00
Concrete	\$87,715.00
Wood Framing, Sheathing & Decking	\$82,620.00
TPO Roof	\$16,940.00
Exterior Doors	\$7,840.00
Interior & Exterior Paint	\$28,435.00
Storm Drainage & Plumbing	\$29,900.00
Electric	\$12,625.00
Steel Beam Repairs (Allowance)	\$6,000.00
Utility Fees	\$2,500.00
TOTAL	\$445,350.00

Concrete Spalling Repairs (Unit Price): \$850 per Additional Cubic Foot of Repairs...
Credit \$250 per Cubic Foot...

Note: Assumes existing 8" thick Base Slab has Pitch towards Center of Slab...



THE CITY OF KEY WEST

Post Office Box 1409 Key West, FL 33041-1409 (305) 809-3883

ADDENDUM NO. 1 & 2

3

This addendum is issued as supplemental information to the bid package for clarification of certain matters of both a general and a technical nature. The referenced Request for Proposal (RFP) package is hereby amended in accordance with the following items:

1. Addendum #1- See attached Meeting Minutes and Sign in Sheet
 - a) REVISED BID DATE OCT 28 3pm
2. Addendum #2-
 - a) Partial Bid Documents_Revised Part 1 and Part 2
 - b) RFI 1-44, 11x17 Format

3. Addendum #3

(1, 2, 1, 3)

All Bidders shall acknowledge receipt and acceptance of this Addendum No. 1 with Attachment by submitting the addendum with their proposal. Proposals submitted without acknowledgement or without this Addendum may be considered non-responsive.

Signature

Barracuda Builders of Key West, Inc.

Name of Business

**2020 / 2021
MONROE COUNTY BUSINESS TAX RECEIPT
EXPIRES SEPTEMBER 30, 2021**

Business Name: BARRACUDA BUILDERS OF KEY WEST INC RECEIPT# 30140-110014

Owner Name: BRYAN ROBERT WOFSEY Business Location: 5601 3RD AVE
Mailing Address: KEY WEST, FL 33040

5601 3RD AVE Business Phone: 305-396-7752
KEY WEST, FL 33040 Business Type: CONTRACTOR (CERTIFIED GENERAL CONTRACTOR)

Employees 1

STATE LICENSE: CGC1521253

Tax Amount	Transfer Fee	Sub-Total	Penalty	Prior Years	Collection Cost	Total Paid
20.00	0.00	20.00	0.00	0.00	0.00	20.00

Paid 102-19-00005841 07/10/2020 20.00

THIS BECOMES A TAX RECEIPT
WHEN VALIDATED

**Danise D. Henriquez, CFC, Tax Collector
PO Box 1129, Key West, FL 33041**

THIS IS ONLY A TAX.
YOU MUST MEET ALL
COUNTY AND/OR
MUNICIPALITY PLANNING
AND ZONING REQUIREMENTS.

MONROE COUNTY BUSINESS TAX RECEIPT

P.O. Box 1129, Key West, FL 33041-1129

EXPIRES SEPTEMBER 30, 2021

Business Name: BARRACUDA BUILDERS OF KEY WEST INC RECEIPT# 30140-110014

Owner Name: BRYAN ROBERT WOFSEY Business Location: 5601 3RD AVE
Mailing Address: KEY WEST, FL 33040

5601 3RD AVE Business Phone: 305-396-7752
KEY WEST, FL 33040 Business Type: CONTRACTOR (CERTIFIED GENERAL CONTRACTOR)

Employees 1

STATE LICENSE: CGC1521253

Tax Amount	Transfer Fee	Sub-Total	Penalty	Prior Years	Collection Cost	Total Paid
20.00	0.00	20.00	0.00	0.00	0.00	20.00

Paid 102-19-00005841 07/10/2020 20.00



CERTIFICATE OF LIABILITY INSURANCE

DATE (MM/DD/YYYY)

1/6/2020

THIS CERTIFICATE IS ISSUED AS A MATTER OF INFORMATION ONLY AND CONFERS NO RIGHTS UPON THE CERTIFICATE HOLDER. THIS CERTIFICATE DOES NOT AFFIRMATIVELY OR NEGATIVELY AMEND, EXTEND OR ALTER THE COVERAGE AFFORDED BY THE POLICIES BELOW. THIS CERTIFICATE OF INSURANCE DOES NOT CONSTITUTE A CONTRACT BETWEEN THE ISSUING INSURER(S), AUTHORIZED REPRESENTATIVE OR PRODUCER, AND THE CERTIFICATE HOLDER.

IMPORTANT: If the certificate holder is an ADDITIONAL INSURED, the policy(ies) must have ADDITIONAL INSURED provisions or be endorsed. If SUBROGATION IS WAIVED, subject to the terms and conditions of the policy, certain policies may require an endorsement. A statement on this certificate does not confer rights to the certificate holder in lieu of such endorsement(s).

PRODUCER Sihle Insurance Group, Inc. 1021 Douglas Ave. Altamonte Springs FL 32714	CONTACT NAME: Kymberly Group	
	PHONE (A/C, No, Ext):	FAX (A/C, No):
E-MAIL ADDRESS:		
INSURER(S) AFFORDING COVERAGE		NAIC #
INSURER A: State National Insurance Company, Inc.		12831
INSURED Kymberly Group Payroll Solutions Inc. 1 West Church Street, Suite 200 Orlando FL 32801	INSURER B:	
	INSURER C:	
	INSURER D:	
	INSURER E:	
	INSURER F:	

COVERAGES

CERTIFICATE NUMBER: 1384039000

REVISION NUMBER:

THIS IS TO CERTIFY THAT THE POLICIES OF INSURANCE LISTED BELOW HAVE BEEN ISSUED TO THE INSURED NAMED ABOVE FOR THE POLICY PERIOD INDICATED. NOTWITHSTANDING ANY REQUIREMENT, TERM OR CONDITION OF ANY CONTRACT OR OTHER DOCUMENT WITH RESPECT TO WHICH THIS CERTIFICATE MAY BE ISSUED OR MAY PERTAIN, THE INSURANCE AFFORDED BY THE POLICIES DESCRIBED HEREIN IS SUBJECT TO ALL THE TERMS, EXCLUSIONS AND CONDITIONS OF SUCH POLICIES. LIMITS SHOWN MAY HAVE BEEN REDUCED BY PAID CLAIMS.

INSR LTR	TYPE OF INSURANCE	ADDL INSD	SUBR WVD	POLICY NUMBER	POLICY EFF (MM/DD/YYYY)	POLICY EXP (MM/DD/YYYY)	LIMITS
	COMMERCIAL GENERAL LIABILITY <input type="checkbox"/> CLAIMS-MADE <input type="checkbox"/> OCCUR GEN'L AGGREGATE LIMIT APPLIES PER: <input type="checkbox"/> POLICY <input type="checkbox"/> PRO-JECT <input type="checkbox"/> LOC OTHER:						EACH OCCURRENCE \$ DAMAGE TO RENTED PREMISES (Ea occurrence) \$ MED EXP (Any one person) \$ PERSONAL & ADV INJURY \$ GENERAL AGGREGATE \$ PRODUCTS - COMP/OP AGG \$ \$
	AUTOMOBILE LIABILITY <input type="checkbox"/> ANY AUTO <input type="checkbox"/> OWNED AUTOS ONLY <input type="checkbox"/> SCHEDULED AUTOS <input type="checkbox"/> HIRED AUTOS ONLY <input type="checkbox"/> NON-OWNED AUTOS ONLY						COMBINED SINGLE LIMIT (Ea accident) \$ BODILY INJURY (Per person) \$ BODILY INJURY (Per accident) \$ PROPERTY DAMAGE (Per accident) \$ \$
	UMBRELLA LIAB <input type="checkbox"/> OCCUR EXCESS LIAB <input type="checkbox"/> CLAIMS-MADE DED RETENTION \$						EACH OCCURRENCE \$ AGGREGATE \$ \$
A	WORKERS COMPENSATION AND EMPLOYERS' LIABILITY ANY PROPRIETOR/PARTNER/EXECUTIVE OFFICER/MEMBER EXCLUDED? (Mandatory in NH) If yes, describe under DESCRIPTION OF OPERATIONS below	Y/N <input type="checkbox"/>	N/A	TGW900096401	1/1/2020	1/1/2021	X PER STATUTE OTH-ER E.L. EACH ACCIDENT \$ 1,000,000 E.L. DISEASE - EA EMPLOYEE \$ 1,000,000 E.L. DISEASE - POLICY LIMIT \$ 1,000,000

DESCRIPTION OF OPERATIONS / LOCATIONS / VEHICLES (ACORD 101, Additional Remarks Schedule, may be attached if more space is required)

Alternate Employer, Barracuda Builders of Key West, Inc. is provided Workers Compensation coverage effective 10/14/18 only for employees leased from Kymberly Group Payroll Solutions, Inc. Pursuant to the client services agreement between Barracuda Builders of Key West, Inc. and Kymberly Group Payroll Solutions, Inc.

CERTIFICATE HOLDER**CANCELLATION**

City of Key West 1300 White Street Key West FL 33040	SHOULD ANY OF THE ABOVE DESCRIBED POLICIES BE CANCELLED BEFORE THE EXPIRATION DATE THEREOF, NOTICE WILL BE DELIVERED IN ACCORDANCE WITH THE POLICY PROVISIONS.
	AUTHORIZED REPRESENTATIVE <i>Cheyl A. Noble</i>

© 1988-2015 ACORD CORPORATION. All rights reserved.



ADDENDUM #1- PRE-BID MEETING MINUTES- ITB # 21-001

PROJECT: Cable Huts Stabilization and Repair Mallory Square

MEETING DATE/TIME: Oct 8 @ 11:00 AM

MEETING LOCATION: Cable Huts at Mallory Square

- I. Project Representatives and Responsibilities
 - A. Owner & Contract Administrator – **City of Key West (City)**
 - i. **Steven McAlearney, Engineering Director**
 - ii. **Kelly Crowe, City Engineer**
 - iii. **Karen Wilman, Senior Construction Manager**
Email- karen.wilman@cityofkeywest-fl.gov
 - iv. **Enid Torregrosa- Historic Preservation Planner**
 - v. **Brandon Celli- HARC Inspector**
 - B. Architect/ Engineer / E.O.R.: **Bender & Associates Architects**
 - i. **David Salay, Architect**
 - C. Affected Utilities: **Call Sunshine 1-800-432-4770. Review Section 01001- General Requirements**
 - D. Permitting Agencies:
 - FDEP Permit - **Not required**
 - USACE Nationwide 3 Authorization – **Not required**
 - Key West Building Department: **Responsibility of Contractor**
- II. All Project Documents- Demand Star www.demandstar.com
 - A. Part 1- Bidding Requirements
 - i. **REVISED- BIDS DUE- OCT 28st- 3:00pm**
City Clerk- 1300 White Street
 - B. Part 2- Contract
 - C. Part 3- Conditions of the contract
 - D. Part 4- General Requirements & Scope of work
 - E. Part 5- Construction Documents
 - F. Part 6- Specifications
 - G. Environmental will be tested by the city and handled under a separate contract by the city, **Prior to start of construction**
- III. Demand Star www.demandstar.com- Any changes to documents or addendums will be posted to Demand Star.
- IV. Scope of Work: Per Drawings and Specifications.
 - i. Access-



1. Main Access- Tifts Street, continue straight between Waterfront Playhouse and Mallory Square Shops.
 2. Mallory Square Pedestrian Bridge to remain open during construction. If this is a problem, please let the City know during bidding process and anticipated time for shut down.
 - ii. Staging- Within designated existing fence area as well as an additional area as shown hatched. Additional stage area will be available at Truman Water and will be review and approved based on needs prior to construction. **Contractor to request additional staging area at the time of NTP. Any additional fencing that is required will be at the Contractors expense.**
 - iii. Coordination with Cruise Schedule
 - iv. Coordination with Mallory Square Sunset Celebrations
 - v. Coordination with Aquarium and HTA
 - vi. Site Security & Safety for Workers & Residents
 - vii. Parking
- B. Notice to Proceed: Issuance / First Chargeable Day: **Within 10 Days of NTP**
- C. Completion: **90 Calendar Days to Final Completion. This includes all inspections and Owner signoff. See Addendum #2**
- D. Liquidated Damages: **\$250 per Day, as noted in the contract.**
- E. Work Hours: **8:00 AM to 7:00 PM, Monday thru Friday. No work should be performed during weekends or City/State/National Holidays unless approved by City.**
- F. Changes in the Work: **Per Approved Change Order or Change Directive**
- G. Inspections: **City Staff/Inspectors/ E.O.R.**
- H. Time Extensions: **Per Approved Change Order or Change Directive**
- I. Regular Meetings: **Weekly**
- J. Materials Testing: **By Contractor**
- V. Questions and Comments-

Addendum 1- Oct 10/14/2020- Meeting Minutes and sign-in sheet/ Historical Report

Addendum 2- anticipated issue date Oct 15,2020 (answers to all RFI)
Final Round of questions by EOD Oct 19, 2020

Karen Wilman, Senior Construction Manager
Email- karen.wilman@cityofkeywest-fl.gov

PROJECT NAME ITB # 21-001- Cable Huts Stabilization & Repair Mallory Square

SIGN-IN SHEET PRE - BID CONFERENCE

Oct 8, 2020

NAME	COMPANY	CELL#	EMAIL
Steven Loer	D.L Porter	941-782-7759	steven@dporter.com
Pete Joergesen	D.L. Porter	631-559-5517	pete@dporter.com
Brynn Wolsky	Barracuda Builders	305 396-7752	info@barracudabuilders.com
Mike Marino	Marino Construction	305-619-2774 239-910-2132	mmarino@marino-construction.com
Alvaro Mercado	CSI	954-892-9870	amercado@contractingspecialists.com
DAVID SALAY	BENDER ARCHITECTS	305.296.1347	DSALAY@BENDERARCHITECTS.COM
Craig Stedekberg	Bender Architects		cstedekberg@benderarchitects
Ryon LaChapelle	SeaTech, Inc.	305.304.8406	RYONL@SEATECH.CC
Minnac Bonnerkamp	Keys Roofing	305-394-4700	keysroofing@ncel BELLSouth.net
MIGUEL LIZ	LIZ CARPENTRY	305 294 5861	OFFICE@LIZCARPENTRY.COM
Emil Torgrossa	HARC City of Key West	305-309-3973	etorgrossa@cityofkeywest-fl.gov

Cable Huts Stabilization and Repair- Addendum 2- RFI 1-RFI 44- 10/16/2020

- | | | | |
|----|--|------|---|
| 1 | Does the city have a budget/engineers estimate for this project? | City | The project is funded. We have a rough estimate but are relying on construction bids. |
| 2 | Due to the 8 to 10 week (56 to 70 days) lead time we're expecting for the exterior doors, the 90 days for permitting and to complete this project is too aggressive/not realistic. Considering no weekend work, we recommend increasing the project duration to 120 days. | City | Duration is changed to 120 calendar day. I added days needed for completion to the bid form. Hoping to order the doors first thing and condense schedule as much as possible. |
| 3 | Please confirm the size of the Nyloplast Drain Basin? | Arch | C1.0 and C1.1 Catch basin is 12" round Drain basin with 12" pipe to existing Mallory Square drain system. |
| 4 | Sheet D1.0 General Demolition Note 9 reads "Paint samples from around the building surfaces should be tested for lead". Please confirm the City will handle the lead based paint testing and any lead-based paint removal. | City | City testing for all enviornmental needs. |
| 5 | Sheet A1.0 General Framing Note 2 states either ZMAX or SS Finish for Hardware/Fasteners. Simpson Strong-Tie has (3) levels of corrosion resistance (ZMax (1.85 oz/sf), Hot Dipped Galvanized (2.00 oz/sf) or 316 Stainless Steel) for pressure treated lumber. We recommend using the mid-level Hot Dipped Galvanized Hardware considering the proximity to salt water and exposure to rain. Please specify the desired finish. | Arch | Sheet A1.0 General framing note 2 should read "Where Wood joists/beams etc, frame into other members, and ledgers are provided, install Simpson "W" series joist hangers with a hot dipped galvanized finish." |
| 6 | Sheet A1.0 Project Scope Note 3 shows "Test existing concrete for mixture composition". Please elaborate on these test requirements. | Arch | All concrete submittals to be approved by the structural engineer. Match composition of existing concrete aggregate and follow Structural General Notes on sheet S0.1 section 300. |
| 7 | Sheet A1.0 General Framing Note 5 reads "...PT Plywood nailed with 8d Galvanized Nails 4" oc along Edges and 8" oc in Field". Sheet A1.0 Project Scope Note 4 reads "Sheath over existing Sheathing using SS Screws". Sheet S0.1 Note 620.5 reads "Roof structural panels shall be nailed with 10d Ring-Shank Stainless Steel Nails at 6" oc at all ends and edges at 6" oc". Please clarify. | Arch | Sheet A1.0 General Framing - Note 5 should read "Install all plywood sheathing to lap joints at roof. Use 3/4" minimum thickness P.T. plywood. Refer to Structural Sheet S0.1 for nailing pattern and fasteners." |
| 8 | Sheet A1.0 Project Scope Note 4 reads "Replace any damaged or decayed members." How do we determine when the lumber is considered "damaged"? | Arch | Sheet A1.0 Project Scope - Note 4 should read "Contact Architect for replacement of any damaged or decayed structural members. Install new horizontal slats and vertical "mansard" supports in the same manner of construction as the East Cable Hut. On the East Cable Hut, remove and replace all the existing horizontal slats and vertical "mansard" supports. Inspect the roof sheathing and assume replacment of 25% of PT roof sheathing. All fasteners for the horizontal and vertical "mansard" framing members will be with stainless steel screws that penetrate a minimum of 1" into adjacent member. " |
| 8a | New note from Architect | | On the West Cable Hut, all roof sheathing and 2x roof framing will need to be replaced, leaving the historic heavy timber members in place. Install new framing and roof sheathing according to best practices and in compliance with the General Framing Notes. Contractor shall assume replacement of 50% of the existing steel beams. Provide cost allowance for steel and credit to City if not required. |
| 9 | Sheet A1.0 Project Scope Note 4 reads "Ensure historic horizontal slat framing is secure, plumb and square, refasten per best practice with SS screws". Due to the age of the structure, most existing members are NOT plumb and square. Please clarify the finish of fasteners and what plumb and square tolerances will be acceptable. | Arch | See Above Note for item #8 |
| 10 | Sheet A1.0 Project Scope Note 6 reads "Water service to both structures...these include water meter, backflow preventer, hose bibs." Sheet C1.1 shows 1 hose bib on the east side of the east hut. Please confirm plumbing scope | City | Water service is a bid alternate by the city. Please provide costs for water service, hose bib to both cable huts, off of a common meter and back flow preventer. |

11	Sheet A1.0 reads "Apply water sealing barrier below F.F.". Please specify waterproofing on interior, exterior or both sides.	Arch	After further site investigation, Architect has determined waterproofing below the finished floor in not cost effective or necessary. Please remove this item from bid consideration.
12	Sheet A1.0 reads "New 2x6 PT wd decking... pre-drill & attach with SS screws." Sheet S1.1 reads "attach with (2) 10d ring-shank nails". Please clarify.	Arch/Struct	Decking to be attached with bugle head #9 Stainless Steel screws 2-1/2" length. Pre-drill screw holes, two per joist.
13	Sheet A3.0, door detail 2 shows "4" W.W. Mesh in 4" Slab". Is this necessary?	Arch	Delete from bid documents.
14	Sheet A3.0 reads "New 2x6 PT stained wd decking for West Hut. The East Hut reads "New 2x6 PT wd decking". Please clarify the finish.	Arch	All floor decking shall be unstained and unfinished, gap 3/8" between boards.
15	Please specify the type of material to be used for the "New curbing for the cable winch assemble/pulley". Will any additional framing/blocking be required under the cable winch assembly/pulley? What fasteners will be required to attach the cable winch/pulley?	Arch	Blocking at mounting points should be double 2x4's or 4x4 fastened to sheathing with screws. Provide blocking under roof sheathing for support.
16	Sheet A5.0, TPO Roof Edge Detail 2; will we replace the existing wood sub-fascia around the perimeter of the roof structure? If so, will this be a PT 1x8?	Arch	Replace the existing sub-fascia and existing 1x6 WD Trim Boards.
17	Sheet A8.0 shows "Waterproof Air Gap Membrane DMX Flexsheet or equivalent." This product is discontinued and now called "DMX AG" which is considered a damp proofing membrane. Manufacturer recommends the "DMX Drain 5X Drainage Membrane" over "Blueskin WP200 Self-Adhered Waterproofing Membrane" applied to the existing concrete walls. Please specify.	Arch	After further site investigation, Architect has determined waterproofing below the finished floor in not cost effective or necessary. Please remove this item from bid consideration.
18	Please specify the grade of lumber to be used for the 2x6 PT Deck Boards. Will these be #2, #1 or Premium Grade lumber? Also, will the deck boards have rounded edges?	Arch	All wood is to be #1 Grade. Decking will have rounded edges.
19	Please specify size, type, style and manufacturer of exterior doors including size of glass, door hardware and door casing requirements.	Arch	DOOR: 36" Chem Pruf 3'0"x7'0" Monolithic RHR rated FPC FL26592 (City wants a slab door, no lite) HARDWARE: Door Comes from manufacturer with Latch, Deadbolt, hinges and frame. Door Closer-Yale Painted Aluminium, Slim Line, Manual Hydraulic, #G5053310, Kick Plate-Schlage Satin Nickel 8"x34" 8400-8x34-619 (All items are OR EQUAL WITH ARCHITECT APPROVAL)
20	Sheet S0.1 note 300.3.A reads "Piers, walls and sump pits to have 2-1/2 gallons of corrosion inhibitor per cubic yard". Considering the age of the structure, is this necessary?	Structural	Yes, the corrosion inhibitor is required. This is a very aggressive environment.
21	Sheet S0.1 note 300.17.A reads "record the temperature and perform one slump test...for every 10 cubic yards of concrete placed." Is this necessary?	Structural	Yes, perform the tests as specified.
22	Sheet S0.1 note 300.17.B reads "Cast and laboratory cure (6) concrete...cylinders..." Standard compressive strength test includes (4) cylinders. Are (6) cylinders necessary?	Structural	Yes, perform the tests as specified. The two extra cylinders are held in reserve if concrete does not come up to strength.
23	Sheet S1.1, Floor Framing Plan shows the estimated volume of spalling repairs and linear footage of crack repairs. Will we base our bid on these estimated quantities?	Structural	Yes, base the bid on the estimated quantities shown on the drawings. Provide units quantities in your bid for add/deduct purposes.
24	Sheet S1.1; How many FJA Anchors are required at the pier to beam connections?	Structural	Provide 2 each end of each beam.
25	Sheet S2.1, detail 1 shows (2) 3/4" adhesive anchors at tank to 4x6 connections. What is the spacing between	Structural	Provide 2 each end of each beam. Space a minimum of 5" apart.
26	Do we need to isolate the new 2x12 ledger from the concrete walls? If so, what type of material/coating?	Structural	Pressure treat all lumber. Isolate with Ice/Water shield between lumber and concrete.
27	Please clarify the type of joist hangers required for the 2x12 floor joists. LUS210 hangers for the typical joists to beam connections? LS90 angles along the radiused wall?	Structural	The LUS210 is an acceptable hanger for the joist to beam connection. Sections 3/S2.1 and 4/S2.1 specify the LS90 angles each face to the radius walls. Use stainless steel hangers, nails and screws. Hot dipped galvanize may be used where stainless is not available.
28	Sheet S5.1 reads "Provide galvanized anodes..." Please specify type and size of anodes.	Structural	Use Sika Ferrogard 670 anodes.
29	Sheet S5.1, detail F; Please specify the thickness of the existing concrete slab.	Structural	Contractor shall assume 8" thick slab at base for bidding purposes.
30	Please specify ceiling mounted light fixtures.	Arch	<u>Vapor Tight</u> T8 LED Linear Fixture for 2 LED T8 Tubes - Industrial LED Light - 4' Long - Part Number: VTLF-2T8

31 Please specify the wall mounted light fixture.	Arch	Superbrightleds WPG-50K28W-S 28W LED Wall Pack - 2,800 Lumens - Glass Lens - 70W Metal Halide Equivalent - 5000K
32 Please specify the size of the sump pumps. Will this pump include a float switch?	Arch	Dayton Submersible Sump Pump, 1/2 HP, Cast Iron, 120V AC, Vertical Float Item # 3BB71 Mfr. Model # 3BB71UNSPSC # 40151512Catalog Page # 2619
33 Will the exposed electrical conduits for the lights, switches and outlets be PVC or Metal?	Arch	PVC and Hydromaxx 1 in. Dia. Non Metallic UL Liquid Tight Electrical Conduit Kit, Straight and Angle Fittings.
34 Several large tree roots are visible along and adjacent to the cable huts. Please confirm these are old tree roots from the tree recently removed by city staff. If not, will the City be responsible for any tree/root trimming	City	
35 Will the infilling of the concrete slab for the east hut be included in deductive alternate 1?	City	Do not include the cost for the concrete slab in the deduct for the east hut
36 Will the new interior masonry piers be included within the deductive alternates 1 and 2?	City	Yes, include the cost of the piers in the decut for alternates 1 & 2
37 In order to excavate for the waterproofing/new concrete footers, we'll need to remove the existing transformer pad on the east side of the east hut. Will we need to rebuild this concrete block transformer pad?	Arch	Sheet D1.0 indicates the pad is to be part of the Demo package.
38 Sheet E1.0 shows the Electrical Panels located on the wall of the Hospitality House. Currently there is an AC Condenser located on the wood deck. Electrical code requires 36" of unobstructed space in front of these panels. Please advise.	Arch	Mount panels on Unistrut attached to the guardrail of the porch. The highest switch should be no more than 6'-7" above the deck finish floor.
39 What is the elevation of the existing wood porch on the Hospitality House? How high above the wood porch elevation will the new electrical panels be?	Arch	The finish floor of the building is El. 8.25'. The deck is approx.. 3" lower. See the above for mounting height.
40 In order to excavate for the waterproofing/new concrete footers, the wood fence on the east side of the property will need to be removed. Do we need to replace this wood fence?	Arch	Remove and replace the fence as required for footer excavation. Match existing.
41 Will the City of Key West test the existing water within the West Hut to ensure this water/fill/debris is NOT contaminated?	City	Yes, see RFI 4 response.
42 Will this project include Re-Mounting and Re-Powering the existing light fixture on the north side of the property?	City	Not at this time.
43 Do we include the spalling repairs needed on the North Door Opening of the West Cable Hut?	Arch	Yes
44 After our site visit, large cracks/fractures are visible on the interior and exterior of the South Side of the East Cable Hut. The existing square shaped reinforcing steel has lost more than 10% of its cross-section. We estimate approximately 28 linear feet of complete removal and replacement of the exposed 8" thick concrete wall. Do we include this full replacement of the 8" wall or bid per the cubic footage on the structural plans?	Arch	For the purpose of bidding, contractor shall assume full replacement of 28 lf of the 8" concrete wall. If 28' is not replaced, credit back to City.

CONTRACT DOCUMENTS FOR:



ITB # 21-001

Cable Huts Stabilization and Repair

October 2, 2020

MAYOR: TERI JOHNSTON

COMMISSIONERS:

GREGORY DAVILA

BILLY WARDLOW

JIMMY WEEKLEY

CLAYTON LOPEZ

SAMUEL KAUFMAN

MARY LOU HOOVER

PREPARED BY:
Karen A Wilman
City of Key West
Engineering Services

CITY OF KEY WEST
KEY WEST, FLORIDA
CONTRACT DOCUMENTS

For

CABLE HUTS STABILIZATION AND REPAIR ITB 21-001

INFORMATION TO BIDDERS

SUBJECT: INVITATION TO BID NO. 21-001:
CITY OF KEY WEST
CABLE HUTS STABILIZATION AND REPAIR

ISSUE DATE: **October 2, 2020**

MAIL OR SPECIAL
DELIVERY REPOSSES TO: CITY CLERK
CITY OF KEY WEST
1300 WHITE STREET
KEY WEST, FL 33040

DELIVER BIDS TO: SAME AS ABOVE.

MANDATORY PRE-BID: **October 8, 2020**

FINAL DATE FOR INQUIRIES: **October 12, 2020**

FINAL DATE FOR RESPONSES: **October 16, 2020**

BIDS MUST BE RECEIVED: **October 28, 2020**

NOT LATER THAN: 3:00 P.M. LOCAL TIME

Table of Contents

Page No.

PART 1 - BIDDING REQUIREMENTS

INVITATION TO BID	1
INSTRUCTIONS TO BIDDER	3
PROPOSAL FORM.....	8
FLORIDA BID BOND	15
ANTI – KICKBACK AFFIDAVIT	17
FLORIDA STATUTES, ON PUBLIC ENTITY CRIMES.....	18
INDEMNIFICATION FORM	21
LOCAL VENDORS FORM.....	22
DOMESTIC PARTNERSHIP AFFIDAVIT	23
CONE OF SILENCE AFFIDAVIT	24
NON-COLUSION AFFIDAVIT.....	25
BIDDER'S CHECKLIST.....	26

PART 2 - CONTRACT

CONTRACT	28
PERFORMANCE BOND.....	30
PAYMENT BOND.....	32

PART 3 - CONDITIONS OF THE CONTRACT

GENERAL CONDITIONS	35
SUPPLEMENTARY CONDITIONS	57

PART 4 - GENERAL REQUIREMENTS & SCOPE OF WORK

SECTION 01001 – GENERAL REQUIREMENTS.....	73
SECTION 01010 – SCOPE OF WORK.....	79
SECTION 01300 – SUBMITTALS.....	81

PART 5 - CONSTRUCTION DRAWINGS

PART 6 – SPECIFICATIONS

PART 7 – HISTORIC ARCHITECTURAL REVIEW COMMISSION (HARC)

PART 1

BIDDING REQUIREMENTS

INVITATION TO BID

Sealed bids for the City of Key West ITB# **21-001 CABLE HUTS STABILIZATION AND REPAIR**, addressed to the City of Key West, will be received at the Office of the City Clerk, 1300 White Street., Key West Florida, 33040 until **3:00 p.m.** on Wednesday, **October 28, 2020** and then publicly opened and read. Any bids received after the time and date specified will not be considered.

Please submit one (1) original, and two (2) flash drives each with one single PDF file of the sections entitled “Bidding Requirements” and “Contract Forms”. Bid package is to be enclosed in a sealed envelope, clearly marked on the outside “ITB # 21-001 CABLE HUTS STABILIZATION AND REPAIR” addressed and delivered to the City Clerk at the address noted above.

The project contemplated consists of providing all site work, materials, equipment and labor necessary to accomplish the following:

Stabilization and repair of the Cable Huts at Mallory Square that includes roof and concrete walls.

Drawings and Specifications may be obtained from Demand Star by Onvia or City of Key West. Please contact Demand Star at www.demandstar.com or call 1-800-711-1712 or www.cityofkeywest-fl.gov

A **Mandatory** Pre-bid meeting will be held at **11:00AM** on **October 8, 2020** at the site location of the **Cable Huts at Mallory Square, Wall Street.**

EACH BID MUST BE SUBMITTED ON THE PRESCRIBED FORM AND ACCOMPANIED BY BID SECURITY AS PRESCRIBED IN THE INSTRUCTIONS TO BIDDERS, PAYABLE TO THE CITY OF KEY WEST, FLORIDA, IN AN AMOUNT NOT LESS THAN FIVE (5) PERCENT OF THE AMOUNT BID.

THE BIDDER MUST BE A LICENSED CONTRACTOR BY THE STATE OF FLORIDA AND SUBMIT PROOF OF SUCH WITH THE BID.

The successful Bidder shall furnish documentation showing that he is in compliance with the licensing requirements of the State and the provisions of Chapter 66 Section 87 of the Code of Ordinances of the City of Key West; within 10 days following the Notice of Award and must demonstrate that he holds at a minimum, the following licenses & certificates;

- A. City of Key West Business Tax License Receipt
- B. A valid Certified General Contractors License issued by the State of Florida.

All bid bonds, insurance contracts, and certificates of insurance shall be either executed by or countersigned by a licensed resident agent of the Surety or Insurance Company having their place of business in the State of Florida, and in all ways complying with the insurance laws of the State of Florida. Further, the said Surety or Insurance Company shall be duly licensed and qualified to do business in the State of Florida.

Before a Contract will be awarded for the work contemplated herein, the CITY will conduct such investigation as is necessary to determine the performance record and ability of the apparent low Bidder to perform the size and type of work specified under this Contract. Upon request, the Bidder shall submit such information as deemed necessary by the CITY to evaluate the Bidder's qualifications.

Any request for information concerning this project must be made in writing, per City of Key West Ordinance Section 2-773, Cone of Silence, to Karen Wilman, Senior Construction Manager at karen.wilman@cityofkeywest-fl.gov

As stated above at the time of the bid submittal the Bidder must provide satisfactory documentation of State Licenses. The Bidder shall furnish documentation showing that he is in compliance with the licensing requirements of County, and City licenses as would be required within ten days of the award. The successful Bidder must also be able to satisfy the CITY Attorney as to such insurance coverage and legal requirements as may be demanded by the Bid in question. The CITY may reject bids for any and/or all of the following reasons: (1) for budgetary reasons, (2) if the bidder misstates or conceals a material fact in its bid, (3) if the bid does not strictly conform to the law or is non-responsive to the bid requirements, (4) if the bid is conditional, or (5) if a change of circumstances occurs making the purpose of the bid unnecessary to the CITY. The CITY may also waive any minor formalities or irregularities in any bid, (6) if such rejection is in the best interest of the CITY.

INSTRUCTIONS TO BIDDERS

1. CONTRACT DOCUMENTS

A. FORMAT

The Contract Documents are divided into parts, divisions, and sections for convenient organization and reference. Generally, there has been no attempt to divide the sections into work performed by the various building trades, work by separate subcontractors, or work required for separate facilities in the project.

B. DOCUMENT INTERPRETATION

The separate sections contained within these Contract Documents are intended to be mutually cooperative and to provide all details reasonably required for the execution of the proposed work.

Should there be any doubt as to the meaning or intent of said Contract Documents, the Bidder should request of the ENGINEER, in writing (at least ten (10) calendar days prior to bid opening) an interpretation thereof. Any interpretation or change in said Contract Documents will be made only in writing in the form of Addenda to the documents which will be available to all registered holders of Contract Documents via Demand star. Bidders shall submit with their Bids, or indicate receipt of, all Addenda. The CITY will not be responsible for any other explanation or interpretations of said Documents.

2. GENERAL DESCRIPTION OF THE PROJECT

A general description of the work to be done is contained in the Invitation to Bid. The scope is specified in applicable parts of these Contract Documents.

3. QUALIFICATION OF CONTRACTORS

The prospective Bidders must meet the statutorily prescribed requirements before award of Contract by the CITY. Bidders must hold or obtain all licenses and/or certificates as required by the State and Local Statutes to bid and perform the work specified herein.

4. BIDDER'S UNDERSTANDING

Each Bidder must inform himself of the conditions relating to the execution of the work, and it is assumed that he will inspect the site and make himself thoroughly familiar with all the Contract Documents. Failure to do so will not relieve the successful Bidder of their obligation to enter a Contract and complete the contemplated work in strict accordance with the Contract Documents. It shall be the Bidder's obligation to verify for themselves and to their complete satisfaction all information concerning site and subsurface conditions.

The CITY will make available to prospective Bidders upon request and at the office of the ENGINEER, prior to bid opening, any information that he may have as to subsurface conditions and surface topography at the worksite.

Each Bidder shall inform themselves of, and the Bidder awarded a Contract shall comply with,

federal, state, and local laws, statutes, and ordinances relative to the execution of the work. This requirement includes, but is not limited to, applicable regulations concerning minimum wage rates, nondiscrimination in the employment of labor, protection of public and employee safety and health, environmental protection, the protection of natural resources, fire protection, burning and non-burning requirements, permits, fees, and similar subjects.

5. TYPE OF BID

A. LUMP SUM

The BID for the work is to be submitted on a lump sum basis. Lump sum prices shall be submitted for all items of work set forth in the bid. All items required to complete the work specified but not included in the bid shall be considered incidental to those set forth in the bid.

6. PREPARATION OF BIDS

A. GENERAL

All blank spaces in the BID form must be filled in, as required, preferably in BLACK ink. All price information shall be shown in both words and figures where required. No changes shall be made in the phraseology of the forms. Written amounts shall govern in case of discrepancy between the amounts stated in writing and the amounts stated in figures. In case of discrepancy between unit prices and extended totals, unit prices shall prevail.

Any BID shall be deemed informal which contains omissions, erasures, alterations, or additions of any kind, or prices uncalled for, or in which any of the prices are obviously unbalanced, or which in any manner shall fail to conform to the conditions of the published Invitation to Bid.

Only one BID from any individual, firm, partnership, or corporation, under the same or different names, will be considered. Should it appear to the CITY that any Bidder is interested in more than one Bid for work contemplated; all Bids in which such Bidder is interested will be rejected.

B. SIGNATURE

The Bidder shall sign their BID in the blank space provided therefore. If Bidder is a corporation, the legal name of the corporation shall be set forth above, together with the signature of the officer or officers authorized to sign Contracts on behalf of the corporation. If Bidder is a partnership, the true name of the firm shall be set forth above, together with the signature of the partner or partners authorized to sign Contracts in behalf of the partnership. If signature is by an agent, other than an officer of a corporation or a member of a partnership, a notarized power-of-attorney must be on file with the CITY prior to opening of Bids or submitted with the Bid, otherwise the Bid will be regarded as not properly authorized.

C. SPECIAL BIDDING REQUIREMENTS

The Bidder's attention is brought to the hiring practices and licenses and permits of the City of Key West. These are defined in the addition to Article 39, ORDINANCES, PERMITS, AND LICENSES, as set forth in the Supplementary Conditions.

The Bidder shall submit with their Bid their experience record showing their experience and expertise in general construction projects and related work. Such experience record shall provide at least five current or recent projects (within the past 5 years) of similar work, within the State Florida and preferably Monroe County. For each project the following information shall be provided:

1. Description and location of work.
2. Contract amount.
3. Dates work was performed.
4. Owner.
5. Name of Owner's contact person and phone number.
6. ENGINEER.
7. Name of ENGINEER's contact person and phone number.

The bidder shall submit with their bid a list of items to be performed by their own labor and that performed by subcontractors or others.

D. ATTACHMENTS

Bidder shall complete and submit the following forms with their bid:

Anti-Kickback Affidavit
Public Entity Crimes Form
Indemnification Form
City of Key West Business License Tax Receipt
Local Vendors Form
Domestic Partnership Affidavit
Cone of Silence Affidavit
Non-Collusion Affidavit
Bidders' Checklist

E. PUBLIC ENTITY CRIMES FORM

Pursuant to the requirements of Chapter 287.133, Laws of Florida, pertaining to the sworn statement on Public Entity Crimes and the Convicted Vendor List, all Bidders shall submit a signed and notarized statement with their Bid on the form provided herein.

7. STATE AND LOCAL SALES AND USE TAXES

Unless the Supplementary Conditions contains a statement that the CITY is exempt from state sales tax on materials incorporated into the work due to the qualification of the work under this Contract, the Contractor, as required by the laws and statutes of the state and its political subdivisions, shall pay all state and local sales and use taxes. Prices quoted in the Bid shall include

all nonexempt sales and use taxes, unless provision is made in the Bid form to separately itemize the tax.

8. SUBMISSION OF BIDS

All BIDS must be submitted not later than the time prescribed, at the place, and in the manner set forth in the Invitation to Bid. BIDS must be made on the BID forms provided herewith, **submit one (1) ORIGINAL and two (2) FLASH DRIVES each containing a single PDF file of the entire bid package.**

Each BID must be submitted in a sealed envelope, so marked as to indicate the Bidder's name and its contents (project name and number) without being opened and addressed in conformance with the instructions in the Invitation to Bid.

9. MODIFICATION OR WITHDRAWAL OF BIDS

Prior to the time and date designated for receipt of BIDS, any BID submitted may be withdrawn by notice to the party receiving BIDS at the place designated for receipt of BIDS. Such notice shall be in writing over the signature of the Bidder or by telegram. If by telegram, written confirmation over the signature of the Bidder shall be mailed and postmarked on or before the date and time set for receipt of BID. No BID may be withdrawn after the time scheduled for opening of BIDS, unless the time specified in paragraph AWARD OF CONTRACT of these Instructions to Bidders shall have elapsed.

10. BID SECURITY

BIDS must be accompanied by cash, a certified check, or cashier's check drawn on a bank in good standing, or a bid bond issued by a Surety authorized to issue such bonds in the state where the work is located, in the amount of five (5) percent of the total amount of the Bid submitted. This bid security shall be given as a guarantee that the Bidder will not withdraw their BID for a period of ninety (90) days after bid opening, and that if awarded the Contract, the successful Bidder will execute the attached Contract and furnish properly executed Performance and Payment Bonds, each in the full amount of the Contract price within the time specified. Agent and Surety phone numbers must be provided.

The Attorney-in-Fact who executes this bond in behalf of the Surety must attach a notarized copy of their power-of-attorney as evidence of their authority to bind the Surety on the date of execution of the bond. Where State Statute requires, certification by a resident agent shall also be provided.

If the Bidder elects to furnish a Bid Bond, he shall use the Bid Bond form bound herewith, or one conforming substantially thereto in form and content.

11. RETURN OF BID SECURITY

Within 15 days after the award of the Contract, the CITY will return the bid securities to all Bidders whose BIDS are not to be further considered in awarding the Contract. Retained bid securities will be held until the Contract has been finally executed, after which all bid securities, other than Bidders' bonds and any guarantees, which have been forfeited, will be returned to the respective Bidders whose Bids they accompanied.

12. AWARD OF CONTRACT

Within ninety (90) calendar days after the opening of Bids, the CITY will accept one of the Bids or will act in accordance with the following paragraphs. The acceptance of the Bid will be by written notice of award, mailed to the office designated in the Bid, or delivered to the Bidder's representative. In the event of failure of the lowest responsive, responsible Bidder to sign the Contract, provide additional documents, insurance certificate(s) and evidence of holding required licenses and certificates, the Owner may award the Contract to the next lowest responsive, responsible Bidder. Such award, if made, will be made within one hundred & twenty (120) days after the opening of Bids.

The CITY reserves the right to accept or reject any or all Bids, and to waive any informalities and irregularities in said Bids.

13. BASIS OF AWARD

The award will be made by the Owner on the basis of the BID from the lowest, responsive, responsible BIDDER which, in the Owner's sole and absolute judgment will best serve the interest of the Owner.

14. EXECUTION OF CONTRACT

The successful Bidder shall, within ten (10) working days after receiving Notice of Award, sign and deliver to the CITY an original Contract and two (2) copies in the form hereto attached, together with the insurance certificate as required in the Contract Documents and evidence of holding required licenses and certificates. Within 10 working days after receiving the signed Contract from the successful Bidder, the City's authorized agent will sign the Contract. Signature by both parties constitutes execution of the Contract.

16. FAILURE TO EXECUTE CONTRACT AND FURNISH BID BOND

The Bidder who has a Contract awarded to them and who fails to promptly and properly execute the Contract shall forfeit the bid security that accompanied their bid, and the bid security shall be retained as liquidated damages by the CITY, and it is agreed that this said sum is a fair estimate of the amount of damages the CITY will sustain in case the Bidder fails to enter into a Contract. Bid security deposited in the form of cash, a certified check, or cashier's check shall be subject to the same requirement as a Bid Bond.

17. TIME OF COMPLETION

The time of completion of the work to be performed under this Contract is the essence of the Contract. Delays and extensions of time may be allowed in accordance with the provisions stated in the General Conditions.

When the Contractor receives a Notice to Proceed, he shall commence work as soon as possible and shall complete all work within **120** calendar days as stipulated in this Bid.

NOTE TO BIDDER: Use preferably BLACK ink for completing this BID form.

PROPOSAL FORM

To: The City of Key West
Address: 1300 White Street, Key West, Florida 33040
Project Title: CABLE HUTS STABILIZATION AND REPAIR
ITB # 21-001

Bidder's contact person for additional information on this BID:

Company Name: _____

Contact Name & Telephone #: _____

Email Address: _____

BIDDER'S DECLARATION AND UNDERSTANDING

The undersigned, hereinafter called the Bidder, declares that the only persons or parties interested in this Bid are those named herein, that this Bid is, in all respects, fair and without fraud, that it is made without collusion with any official of the Owner, and that the Bid is made without any connection or collusion with any person submitting another Bid on this Contract.

The Bidder further declares that he has carefully examined the Contract Documents for the construction of the project, that he has personally inspected the site, that he has satisfied himself as to the quantities involved, including materials and equipment, and conditions of work involved, including the fact that the description of the quantities of work and materials, as included herein, is brief and is intended only to indicate the general nature of the work and to identify the said quantities with the detailed requirements of the Contract Documents, and that this Bid is made according to the provisions and under the terms of the Contract Documents, which Documents are hereby made a part of this Bid.

CONTRACT EXECUTION

The Bidder agrees that if this Bid is accepted, he will, within 10 days, not including Sundays and legal holidays, after Notice of Award, sign the Contract in the form annexed hereto, and will at that time, deliver to the Owner evidence of holding required licenses and certificates, and will, to the extent of their Bid, furnish all machinery, tools, apparatus, and other means of construction and do the work and furnish all the materials necessary to complete all work as specified or indicated in the Contract Documents.

CERTIFICATES OF INSURANCE

Bidder agrees to furnish the Owner, before commencing the work under this Contract, the certificates of insurance as specified in these Documents.

START OF CONSTRUCTION AND CONTRACT COMPLETION TIME

The Bidder further agrees to begin work within 10 calendar days after the date of the Notice to proceed and to complete the project, in all respects within **120** calendar days after the date of the Notice to Proceed.

LIQUIDATED DAMAGES

In the event the Bidder is awarded the Contract and shall fail to complete the work within the time limit or extended time limit agreed upon, as more particularly set forth in the Contract Documents, liquidated damages shall be paid to the Owner at the rate of \$250.00 per day for all work awarded until the work has been satisfactorily completed as provided by the Contract Documents.

ADDENDA

The Bidder hereby acknowledges that he has received Addenda No's. _____, _____, _____, _____, _____, _____, _____, _____, _____, _____, _____ (Bidder shall insert No. of each Addendum received) and agrees that all addenda issued are hereby made part of the Contract Documents, and the Bidder further agrees that their Bid(s) includes all impacts resulting from said addenda.

SALES AND USE TAXES

The Bidder agrees that all federal, state, and local sales and use taxes are included in the stated bid prices for the work.

LUMP SUM

The Bidder further proposes to accept as full payment for the work proposed herein the amounts computed under the provisions of the Contract Documents and based on the following lump sum amounts. The Bidder agrees that the lump sum represent a true measure of the labor and materials required to perform the work, including all allowances for overhead and profit for each type and unit of work called for in these Contract Documents.

PROPOSAL FORM

Number of Days for Completion _____(0)

1. BASE BID

1- East Hut LS \$ _____(1)

1- West Hut LS \$ _____(2)

Utility Fee Allowance (Keys Energy service fees)
1 LS \$ _____(3)

TOTAL LUMP SUM BASE BID (1) + (2) + (3) : \$ _____(4)

TOTAL LUMP SUM BASE BID:

\$ _____ Dollars & _____ Cents
(4) *amount written in words*

BASE BID ADD OR DEDUCT ALTERNATES

NOTE: OWNER HAS THE RIGHT TO ACCEPT OR REJECT ANY, ALL, OR NO BID ALTERNATE ITEMS. THE TOTAL OF BASE BID PLUS THE SUM OF OWNER SELECTED BID ALTERNATES WILL A BASIS OF EVALUATING LOW BIDDER AND BASIS OF AWARD.

Base Bid: Pavilion A (Front pavilion facing Virginia Street), Entrance, and minor utility work to Pavilion B shall be included within the base bid of this project. Work shall include exterior of Pavilion A, interior build out of Pavilion A, Entrance build out, and all utilities throughout Pavilion A. Pavilion B utilities shall be stubbed in for future development along with window/wall infill to fully enclose Pavilion B.

1. A Deduct Alternate for the floor, floor framing in East Hut

1 LS \$ _____

2. A Deduct Alternate for the floor, floor framing in West Hut

1 LS \$ _____

3. A Deduct Alternate for Infilling (3) openings at West Hut, including door and frame cost.

1 LS \$ _____

4. A Deduct Alternate for new water services and hose bibbs to both Huts

1 LS \$ _____

Name

Street

City

State

Zip

Name

Street

City

State

Zip

SURETY

_____ whose address is

Street

City

State

Zip

BIDDER

The name of the Bidder submitting this Bid is

_____ doing business at

Street

City

State

Zip

which is the address to which all communications concerned with this Bid and with the Contract shall be sent.

The names of the principal officers of the corporation submitting this Bid, or of the partnership, or of all persons interested in this Bid as principals are as follows:

If Sole Proprietor or Partnership

IN WITNESS hereto the undersigned has set their (its) hand this _____ day of _____ 2020.

Signature of Bidder

Title

If Corporation

IN WITNESS WHEREOF the undersigned corporation has caused this instrument to be executed and its seal affixed by its duly authorized officers this _____ day of _____ 2020.

(SEAL)

Name of Corporation

By _____

Title _____

Attest _____

Secretary

FLORIDA BID BOND

BOND NO. _____

AMOUNT: \$ _____

KNOW ALL MEN BY THESE PRESENTS, that _____

hereinafter called the PRINCIPAL, and _____

a corporation duly organized under the laws of the State of _____

having its principal place of business at _____

_____ in the State of _____,

and authorized to do business in the State of Florida, as SURETY, are held and firmly bound unto

hereinafter called the OBLIGEE, in the sum of _____

DOLLARS (\$ _____) for the payment for which we bind ourselves, our heirs, executors, administrators, successors, and assigns, jointly and severally, firmly by these present.

THE CONDITION OF THIS BOND IS SUCH THAT:

WHEREAS, the PRINCIPAL is herewith submitting their or its Bid for

ITB # 21-001 / CABLE HUT STABILIZATION AND REPAIR / IS43022001 said Bid, by reference thereto, being hereby made a part hereof.

WHEREAS, the PRINCIPAL contemplates submitting or has submitted a bid to the OBLIGEE for the furnishing of all labor, materials (except those to be specifically furnished by the CITY), equipment, machinery, tools, apparatus, means of transportation for, and the performance of the work covered in the Bid and the detailed Specifications, entitled:

ITB # 21-001 / CABLE HUT STABILIZATION AND REPAIR / IS43022001

WHEREAS, it was a condition precedent to the submission of said bid that a cashier's check, certified check, or bid bond in the amount of five (5) percent of the base bid be submitted with said bid as a guarantee that the Bidder would, if awarded the Contract, enter into a written Contract with the CITY for the performance of said Contract, within 10 working days after written notice having been given of the award of the Contract.

NOW, THEREFORE, the conditions of this obligation are such that if the PRINCIPAL within 10 consecutive calendar days after written notice of such acceptance, enters into a written Contract with the OBLIGEE and furnishes the Performance and Payment Bonds, each in an amount equal to 100 percent of the base bid, satisfactory to the CITY, then this obligation shall be void; otherwise the sum herein stated shall be due and payable to the OBLIGEE and the Surety herein agrees to pay said sum immediately upon demand of the OBLIGEE in good and lawful money of the United States of America, as liquidated damages for failure thereof of said PRINCIPAL.

Signed and sealed this _____ day of _____, 2020.

PRINCIPAL

By _____ STATE OF _____)
: SS
COUNTY OF _____)

SURETY

By _____

SWORN STATEMENT UNDER SECTION 287.133(3)(A)
FLORIDA STATUTES, ON PUBLIC ENTITY CRIMES

THIS FORM MUST BE SIGNED IN THE PRESENCE OF A NOTARY PUBLIC OR OTHER OFFICER AUTHORIZED TO ADMINISTER OATHS.

1. This sworn statement is submitted with Bid or Bid for _____

2. This sworn statement is submitted by _____
(Name of entity submitting sworn statement)

whose business address is _____

and (if applicable) its Federal Employer Identification Number (FEIN) is _____

(If the entity has no FEIN, include the Social Security Number of the individual
signing this sworn statement _____

3. My name is _____
(Please print name of individual signing)

and my relationship to the entity named above is _____

4. I understand that a “public entity crime” as defined in Paragraph 287.133(1)(g), Florida Statutes, means a violation of any state or federal law by a person with respect to and directly related to the transaction of business with any public entity or with an agency or political subdivision of any other state or with the United States, including but not limited to, any bid or contract for goods or services to be provided to any public or an agency or political subdivision of any other state or of the United States and involving antitrust, fraud, theft, bribery, collusion, racketeering, conspiracy, material misrepresentation.

5. I understand that “convicted” or “conviction” as defined in Paragraph 287.133(1)(b), Florida Statutes, means a finding of guilt or a conviction of a public entity crime, with or without an adjudication guilt, in any federal or state trial court of record relating to charges brought by indictment information after July 1, 1989, as a result of a jury verdict, nonjury trial, or entry of a plea of guilty or nolo contendere.

6. I understand that an “affiliate” as defined in Paragraph 287.133(1)(a), Florida Statutes, means

- a. A predecessor or successor of a person convicted of a public entity crime; or
 - b. An entity under the control of any natural person who is active in the management of the entity and who has been convicted of a public entity crime. The term “affiliate” includes those officers, directors, executives, partners, shareholders, employees, members, and agents who are active in the management of an affiliate. The ownership by one person of shares constituting controlling interest in another person, or a pooling of equipment or income among persons when not for fair market value under an arm’s length agreement, shall be a prima facie case that one person controls another person. A person who knowingly enters into a joint venture with a person who has been convicted of a public entity crime in Florida during the preceding 36 months shall be considered an affiliate.
7. I understand that a “person” as defined in Paragraph 287.133(1)(8), Florida Statutes, means any natural person or entity organized under the laws of any state or of the United States with the legal power to enter into a binding contract and which bids or applies to bid on contracts for the provision of goods or services let by a public entity, or which otherwise transacts or applies to transact business with public entity. The term “person” includes those officers, directors, executives, partners, shareholders, employees, members, and agents who are active in management of an entity.
8. Based on information and belief, the statement which I have marked below is true in relation to the entity submitting this sworn statement. (Please indicate which statement applies).

_____ Neither the entity submitting this sworn statement, nor any officers, directors, executives, partners, shareholders, employees, members, or agents who are active in management of the entity, nor any affiliate of the entity have been charged with and convicted of a public entity crime subsequent to July 1, 1989, AND (Please indicate which additional statement applies.)

_____ There has been a proceeding concerning the conviction before a hearing of the State of Florida, Division of Administrative Hearings. The final order entered by the hearing officer did not place the person or affiliate on the convicted vendor list. (Please attach a copy of the final order.)

_____ The person or affiliate was placed on the convicted vendor list. There has been a subsequent proceeding before a hearing officer of the State of

Florida, Division of Administrative Hearings. The final order entered by the hearing officer determined that it was in the public interest to remove the person or affiliate from the convicted vendor list. (Please attach a copy of the final order.)

_____ The person or affiliate has not been put on the convicted vendor list. (Please describe any action taken by or pending with the Department of General Services.)

(Signature)

(Date)

STATE OF _____

COUNTY OF _____

PERSONALLY, APPEARED BEFORE ME, the undersigned authority,

_____ who, after first being sworn by me, affixed his/her
(Name of individual signing)

Signature in the space provided above on this _____ day of _____, 2020.

My commission expires:

NOTARY PUBLIC

INDEMNIFICATION

To the fullest extent permitted by law, the CONTRACTOR expressly agrees to indemnify and hold harmless the City of Key West, their officers, directors, agents, and employees (herein called the “indemnitees”) from liabilities, damages, losses and costs, including, but not limited to, reasonable attorney’s fees and court costs, such legal expenses to include costs incurred in establishing the indemnification and other rights agreed to in this Paragraph, to persons or property, to the extent caused by the negligence, recklessness, or intentional wrongful misconduct of the CONTRACTOR, its Subcontractors or persons employed or utilized by them in the performance of the Contract. Claims by indemnitees for indemnification shall be limited to the amount of CONTRACTOR’s insurance or \$1 million per occurrence, whichever is greater. The parties acknowledge that the amount of the indemnity required hereunder bears a reasonable commercial relationship to the Contract and it is part of the project specifications or the bid documents, if any.

The indemnification obligations under the Contract shall not be restricted in any way by any limitation on the amount or type of damages, compensation, or benefits payable by or for the CONTRACTOR under workers’ compensation acts, disability benefits acts, or other employee benefits acts, and shall extend to and include any actions brought by or in the name of any employee of the CONTRACTOR or of any third party to whom CONTRACTOR may subcontract a part or all of the Work. This indemnification shall continue beyond the date of completion of the work.

CONTRACTOR: _____

SEAL:

Address

Signature

Print Name

Title

DATE: _____

LOCAL VENDOR CERTIFICATION PURSUANT TO CKW ORDINANCE 09-22 SECTION 2-798

The undersigned, as a duly authorized representative of the vendor listed herein, certifies to the best of his/her knowledge and belief, that the vendor meets the definition of a "Local Business." For purposes of this section, "local business" shall mean a business which:

- a. Principle address as registered with the FL Department of State located within 30 miles of the boundaries of the city, listed with the chief licensing official as having a business tax receipt with its principle address within 30 miles of the boundaries of the city for at least one year immediately prior to the issuance of the solicitation.
- b. Maintains a workforce of at least 50 percent of its employees from the city or within 30 miles of its boundaries.
- c. Having paid all current license taxes and any other fees due the city at least 24 hours prior to the publication of the call for bids or request for Bids.

- Not a local vendor pursuant to Ordinance 09-22 Section 2-798
- Qualifies as a local vendor pursuant to Ordinance 09-22 Section 2-798

If you qualify, please complete the following in support of the self-certification & submit copies of your County and City business licenses. Failure to provide the information requested will result in denial of certification as a local business.

Business Name _____ Phone: _____

Current Local Address: _____ Fax: _____
(P.O Box numbers may not be used to establish status)

Length of time at this address: _____

Date: _____
Signature of Authorized Representative

STATE OF _____ COUNTY OF _____

The foregoing instrument was acknowledged before me this _____ day of _____, 2020.

By _____, of _____
(Name of officer or agent, title of officer or agent) (Name of corporation acknowledging)

or has produced identification _____ as identification
(Type of identification)

Signature of Notary

Return Completed form with
Supporting documents to:
City of Key West Purchasing

Print, Type or Stamp Name of Notary

Title or Rank

BIDDER'S CHECKLIST

(Note: The purpose of this checklist is to serve as a reminder of major items to be addressed in submitting a bid and is not intended to be all inclusive. It does not alleviate the Bidder from the responsibility of becoming familiar with all aspects of the Contract Documents and proper completion and submission of their bid.)

1. All Contract Documents thoroughly read and understood. []
2. All blank spaces in Bid filled in, using black ink. []
3. Total and unit prices added correctly and attached Schedule of Values []
4. Addenda acknowledged. []
5. Subcontractors are named as indicated in the Bid. []
6. Experience record included. []
7. Bid signed by authorized officer. []
8. Bid Bond completed and executed, including power-of-attorney dated the same date as Bid Bond. []
9. Bidder familiar with federal, state, and local laws, ordinances, rules and regulations affecting performance of the work. []
10. Bidder, if successful, able to obtain and/or demonstrate possession of required licenses and certificates within (10) ten calendar days after receiving a Notice of Award. []
11. BID submitted intact with the volume entitled "Bidding Requirements" and "Contract Forms", 1 original, and 2 flash drives as stated in the invitation to bid. []
12. Bid Documents submitted in sealed envelope and addressed and labeled in conformance with the instructions in the Invitation to Bid. []

PART 2

CONTRACT FORMS

CONTRACT

This Contract, made and entered into this _____ day of _____ 2020,

by and between the CITY OF KEY WEST, hereinafter called the "Owner", and _____

hereinafter called the "Contractor";

WITNESSETH:

The Contractor, in consideration of the sum to be paid them by the Owner and of the covenants and agreements herein contained, hereby agrees at their own proper cost and expense to do all the work and furnish all the materials, tools, labor, and all appliances, machinery, and appurtenances for ITB# 21-001, **CABLE HUTS STABILIZATION AND REPAIR**, Key West, Florida to the extent of the Bid made by the Contractor, dated the _____ th day of _____ 2020, all in full compliance with the Contract Documents referred to herein.

The CONTRACT DOCUMENTS, including the signed copy of the BID, BID BOND, CONTRACT FORM, SUMMARY OF WORK, SPECIFICATIONS, DRAWINGS, GENERAL & SUPPLEMENTARY CONDITIONS OF THE CONTRACT.

In consideration of the performance of the work as set forth in these Contract Documents, the Owner agrees to pay to the Contractor the amount bid in the Bid as adjusted in accordance with the Contract Documents, or as otherwise herein provided, and to make such payments in the manner and at the times provided in the Contract Documents.

The Contractor agrees to complete the work within ninety (**120**) calendar days and to accept as full payment hereunder the amounts computed as determined by the Contract Documents and based on the said BID.

The Contractor agrees to remedy all defects appearing in the work or developing in the materials furnished and the workmanship performed under this Contract during the warranty period after the date of final acceptance of the work by the Owner, and further agrees to indemnify and save the Owner harmless from any costs encountered in remedying such defects.

It is agreed that the Contract, based upon the BID, shall be fully complete within the stated number of consecutive calendar days from the date the Notice to Proceed is issued.

In the event the Contractor fails to complete the work within the time limit or extended time limit agreed upon, as more particularly set forth in the Contract Documents, liquidated damages shall be paid at a rate of **\$250.00** per day. Sundays and legal holidays shall be included in determining days in default.

This contract will automatically expire upon completion of the project. Contractors warranty obligations remain in effect.

IN WITNESS WHEREOF, we, the parties hereto, each herewith subscribe the same this

_____ Day of _____, A.D., 2020.

CITY OF KEY WEST

By (Printed Name)_____

By (Signature)_____

Title City Manager (OR DESIGNATED REPRESENTATIVE)

CONTRACTOR

By (Printed Name)_____

By (Signature)_____

Title_____

FLORIDA PERFORMANCE BOND

BOND NO. _____

AMOUNT: \$ _____

KNOW ALL MEN BY THESE PRESENTS, that in accordance with Florida Statutes Section 255.05, _____

with offices, at _____

hereinafter called the CONTRACTOR, (Principal), and _____

with offices, at _____

a corporation duly organized and existing under and by virtue of the laws of the State of _____, hereinafter called the SURETY, and authorized to transact business within the State of Florida, as SURETY, are held and firmly bound CITY OF KEY WEST,

represented by its _____, hereinafter called the City (Obligee), in the sum of:

_____ DOLLARS (\$ _____),

lawful money of the United States of America, for the payment of which, well and truly be made to the CITY, and the CONTRACTOR and the SURETY bind themselves and each of their heirs, executors, administrators, successors, and assigns, jointly and severally, firmly by these presents as follows:

THE CONDITION OF THE ABOVE OBLIGATION IS SUCH THAT:

WHEREAS, the CONTRACTOR has executed and entered into a certain Contract hereto attached, with the CITY, dated _____, 2020, to furnish at their own cost, charges, and expense all the necessary materials, equipment, and/or labor in strict and express accordance with said Contract and the Contract Documents as defined therein, all of which is made a part of said Contract by certain terms and conditions in said Contract more particularly mentioned, which Contract, consisting of the various Contract Documents is made a part of this Bond as fully and completely as if said Contract Documents were set forth herein;

NOW THEREFORE, the conditions of this obligation are such that if the above bounden CONTRACTOR:

1. Shall in all respects comply with the terms and conditions of said Contract and their obligation there under, including the Contract Documents (which include the permit form, coral relocation plan, specifications, and conditions as prepared by the CITY, invitation to bid, instructions to bidders, the CONTRACTOR'S bid as accepted by the above CITY, the bid and contract performance and payment bonds, and all addenda, if any, issued prior to the opening of bids),

being made a part of this bond by reference, at the times and in the manner prescribed in the contract; and

2. Promptly makes payments to all claimants, as defined in Section 255.05(1), Florida Statutes, supplying PRINCIPAL with labor, materials, or supplies, used directly or indirectly by PRINCIPAL in the prosecution of the work provided for in the contract; and

3. Pays CITY all losses, costs, expenses, damages, attorney's fees, including appellate proceedings, injury or loss of whatever kind and however arising including, without limitation, delay damages to which said CITY may be subject by reason of any wrongdoing, misconduct, want of care or skill, negligence, failure of performance, breach, failure to petition within the prescribed time, or default, including patent infringements, on the part of said CONTRACTOR, their agents or employees, in the execution or performance of said Contract; and

4. Performs the guarantee of all work and materials furnished under the contract for the time specified in the contract, then this obligation shall be void; otherwise, to remain in full force and effect for the term of said Contract.

AND, the said Surety for value received, hereby stipulates and agrees that no change involving any extension of time, or addition to the terms of the Contract Documents, or to the work to be performed, or materials to be furnished there under shall affect said obligation of said Surety on this Bond, and the said Surety does hereby waive notice of any such changes, extension of time, alterations, or additions of the terms of the Contract Documents, or to the work.

Any action instituted by a claimant under this bond for payment must be in accordance with the notice and time limitation provisions in Section 255.05(2), Florida Statutes.

IN WITNESS WHEREOF, the above parties bonded together have executed this instrument this day of _____, 2020, the name and corporate seal of each corporate party being hereto affixed and those presents duly signed by its undersigned representative, pursuant to authority of its governing body.

CONTRACTOR

By: _____ (Seal)

_____ Attest

SURETY

By _____ (Seal)

_____ Attest

FLORIDA PAYMENT BOND

BOND NO _____

AMOUNT: \$ _____

KNOW ALL MEN BY THESE PRESENTS, that in accordance with Florida Statutes Section 255.05, _____

with offices at _____

hereinafter called the CONTRACTOR, (Principal), and

_____ with offices at _____

a corporation duly organized and existing under and by virtue of the laws of the State of _____, hereinafter called the SURETY, and authorized to transact business within the State of Florida, as SURETY, are held and firmly bound CITY OF KEY WEST,

represented by its _____, hereinafter called the City (Obligee), in the sum of:

_____ DOLLARS (\$ _____), lawful money of the United States of America, for the payment of which, well and truly be made to the CITY, and the CONTRACTOR and the SURETY bind themselves and each of their heirs, executors, administrators, successors, and assigns, jointly and severally, firmly by these presents as follows:

THE CONDITION OF THE ABOVE OBLIGATION IS SUCH THAT:

WHEREAS, the CONTRACTOR has executed and entered into a certain Contract for

ITB 21-001 / CABLE HUTS STABILIZATION AND REPAIR / IS43022001

attached hereto, with the CITY, dated _____, 2020, to furnish at their own cost, charges, and expense the necessary materials, equipment, and/or labor in strict and express accordance with said Contract and the plans, drawings (if any), and specifications prepared by the CITY, all of which is made a part of said Contract by certain terms and conditions in said Contract more particularly mentioned, which Contract, consisting of the various Contract Documents specifically mentioned herein and relative hereto, is made a part of this Bond as fully and completely as if said Contract Documents were set forth herein.

NOW THEREFORE, the conditions of this obligation are such that if the above bounden CONTRACTOR shall in all respects comply with the terms and conditions of said Contract and their obligation thereunder, including the Contract Documents (which include the permit form,

coral relocation plan, the specifications, and conditions prepared by the CITY, invitation to bid, instructions to bidders, the CONTRACTOR'S bid as accepted by the CITY, the bid and contract and payment bonds, and all addenda, if any, issued prior to the opening of bids), and further that if said CONTRACTOR shall promptly make payments to all persons supplying materials, equipment, and/or labor, used directly or indirectly by said CONTRACTOR or SUBCONTRACTORS in the prosecution of the work for said contract in accordance with Florida Statutes, Section 255.05 or Section 713.23, then this obligation shall be void; otherwise to remain in full force and effect for the term of said contract, including and all guarantee periods as specifically mentioned in said Contract Documents.

AND, the said SURETY for value received, hereby stipulates and agrees that no change involving any extension of time, or addition to the terms of the Contract or to the work to be performed, or materials to be furnished thereunder, or in the Contract Documents and specifications accompanying the said contract shall affect said obligation of said SURETY on this Bond, and the said SURETY does hereby waive notice of any such changes, extension of time, alternations, or additions of the terms of the Contract, or to the work, to the Contract Documents, or to the specifications.

Claimant shall give written notice to the CONTRACTOR and the SURETY as required by Section 255.05 or Section 713.23, Florida Statutes. Any action instituted against the CONTRACTOR or SURETY under this bond for payment must be in accordance with the notice and time limitation provisions in Section 255.05(2) or Section 713.23, Florida Statutes.

IN WITNESS WHEREOF, the above parties bounded together have executed this instrument this _____ day of _____, 2020, the name and corporate seal of each corporate party being hereto affixed and those presents duly signed by its undersigned representative, pursuant to authority of its governing body.

CONTRACTOR

By: _____ (Seal)

Attest

SURETY

By _____ (Seal)

Attest

PART 3

CONDITIONS OF THE CONTRACT

GENERAL CONDITIONS
CONTENTS

Article

DEFINITIONS

1. AS APPROVED
2. AS SHOWN, AND AS INDICATED
3. BIDDER
4. CONTRACT DOCUMENTS
5. CONTRACTOR
6. CONTRACT COMPLETION
7. DAYS
8. DRAWINGS
9. ENGINEER
10. NOTICE
11. OR EQUAL
12. OWNER
13. PLANS
14. SPECIFICATIONS
15. NOTICE TO PROCEED
16. SUBSTANTIAL COMPLETION
17. WORK

CONTRACT DOCUMENTS

18. INTENT OF CONTRACT DOCUMENTS
19. DISCREPANCIES AND OMISSIONS
20. CHANGES IN THE WORK
21. EXAMINATION AND VERIFICATION OF CONTRACT DOCUMENTS
22. DOCUMENTS TO BE KEPT ON THE JOBSITE
23. ADDITIONAL CONTRACT DOCUMENTS
24. OWNERSHIP OF CONTRACT DOCUMENTS

THE ENGINEER

25. AUTHORITY OF THE ENGINEER
26. DUTIES AND RESPONSIBILITIES OF THE ENGINEER
27. LIMITATIONS ON ENGINEER'S RESPONSIBILITIES
28. REJECTED WORK
29. LINES AND GRADES
30. SUBMITTALS
31. DETAIL DRAWINGS AND INSTRUCTIONS

THE CONTRACTOR AND THEIR EMPLOYEES

32. CONTRACTOR, AN INDEPENDENT AGENT
32. (a) ASSIGNMENT OF CONTRACT

33. SUBCONTRACTING
34. INSURANCE AND LIABILITY
 - A. GENERAL
 - B. CONTRACTOR AND SUB-CONTRACTOR INSURANCE
 - C. COMPENSATION AND EMPLOYER'S LIABILITY INSURANCE
 - D. GENERAL LIABILITY INSURANCE (INCLUDING AUTOMOBILE)
 - E. BUILDER'S RISK ALL RISK INSURANCE
 - F. NO PERSONAL LIABILITY OF PUBLIC OFFICIALS
35. INDEMNITY
36. EXCLUSION OF CONTRACTOR CLAIMS
37. TAXES AND CHARGES
38. REQUIREMENTS OF STATE LAW FOR PUBLIC WORKS PROJECTS
39. CODES, ORDINANCES, PERMITS, AND LICENSES
40. SUPERINTENDENCE
41. RECEPTION OF ENGINEER'S COMMUNICATIONS
42. SAFETY
43. PROTECTION OF WORK AND PROPERTY
44. RESPONSIBILITY OF CONTRACTOR TO ACT IN AN EMERGENCY
45. MATERIALS AND APPLIANCES
46. CONTRACTORS' AND MANUFACTURERS' COMPLIANCE WITH STATE SAFETY, OSHA AND OTHER CODE REQUIREMENTS
47. SUBSTITUTION OF MATERIALS
48. TESTS, SAMPLES, AND OBSERVATIONS
49. ROYALTIES AND PATENT
50. CONTRACTOR'S RIGHT TO TERMINATE CONTRACT
51. CORRECTION OF DEFECTIVE WORK DURING WARRANTY PERIOD

PROGRESS OF THE WORK

52. BEGINNING OF THE WORK
53. SCHEDULES AND PROGRESS REPORTS
54. PROSECUTION OF THE WORK
55. OWNER'S RIGHT TO RETAIN IMPERFECT WORK
56. OWNER'S RIGHT TO DO WORK
57. OWNER'S RIGHT TO TRANSFER EMPLOYMENT
58. DELAYS AND EXTENSION OF TIME
59. DIFFERING SITE CONDITION

GENERAL CONDITIONS
CONTENTS

Article

- 60. LIQUIDATED DAMAGES
- 61. OTHER CONTRACTS
- 62. USE OF PREMISES
- 63. SUBSTANTIAL COMPLETION DATE
- 64. PERFORMANCE TESTING
- 65. OWNER'S USE OF PORTION OF THE WORK
- 66. CUTTING AND PATCHING
- 67. CLEANING UP

PAYMENT

- 68. CHANGE ORDERS
 - A. UNIT PRICE
 - B. LUMP SUM
 - C. COST REIMBURSEMENT
WORK
- 69. PARTIAL PAYMENTS
 - A. GENERAL
 - B. ESTIMATE
 - C. DEDUCTION FROM ESTIMATE
 - D. QUALIFICATIONS FOR
PARTIAL PAYMENT FOR
MATERIALS DELIVERED
 - E. PAYMENT
- 70. CLAIMS FOR EXTRA WORK
- 71. RELEASE OF LIENS OR CLAIMS
- 72. FINAL PAYMENT
- 73. NO WAIVER OF RIGHTS
- 74. ACCEPTANCE OF FINAL PAYMENT
CONSTITUTES RELEASE

DEFINITIONS

Whenever in the Contract Documents the following terms are used, the intent and meaning shall be interpreted as follows:

1. AS APPROVED

The words “as approved”, unless otherwise qualified, shall be understood to be followed by the words “by the ENGINEER for conformance with the Contract Document”.

2. AS SHOWN, AND AS INDICATED

The words “as shown” and “as Indicated” shall be understood to be followed by the words “on the Drawings”.

3. BIDDER

The person or persons, partnership, firm, or corporation submitting a Bid for the work contemplated.

4. CONTRACT DOCUMENTS

The “Contract Documents” consist of the Bidding Requirements, Contract Forms, Conditions of the Contract, Specifications, Drawings, all modifications thereof incorporated into the Documents before their execution, Change Orders, and all other requirements incorporated by specific reference thereto. These form the Contract.

5. CONTRACTOR

The person or persons, partnership, firm, or corporation who enters into the Contract awarded they by the OWNER.

6. CONTRACT COMPLETION

The “Contract Completion” is the date the OWNER accepts the entire work as being in compliance with the Contract Documents, or formally waives nonconforming work to extent of nonconformity, and issues the final payment in accordance with the requirements set forth in Article, “Final Payment” of these General Conditions.

7. DAYS

Unless otherwise specifically stated, the term “days” will be understood to mean calendar days. Business day or working day means any day other than Saturday, Sunday, or legal holiday.

8. DRAWINGS

The term “Drawings” refers to the official Drawings, Profiles, cross sections, elevations, details, and other working drawings and supplementary drawings, or reproductions thereof, signed by the ENGINEER, which shows the location, character, dimensions, and details of the work to be performed. Drawings may either be bound in the same book as the balance of the Contract Documents, or bound in separate sets, and are a part of the Contract Documents, regardless of the method of binding.

9. ENGINEER

The person or organization identified as such in the Contract Documents. The Term “ENGINEER” means ARCHITECT OR ENGINEER OF RECORD. or their authorized representative.

10. NOTICE



ADDENDUM #3- ITB # 21-001

PROJECT: Cable Huts Stabilization and Repair Mallory Square

DATE: 10.26.2020

1. RFI- 45- Section 1/A8.0 shows the TPO roof with no insulation. Section 2/A5.0 shows roof with insulation. Please Clarify.
Answer: No insulation is required in the roof so the cost can be removed from the scope of work.

2. RFI- 46- The Proposal Form references a pre itemized schedule of values located in part 4 of the documents. I can't find this pre-itemized schedule of values. Please clarify.
Answer: No schedule of Values was provided in part 4, please strike the below paragraph from the PROPOSAL FORM.

“Provided in Part 4 of these documents is a pre-itemized Schedule of Values broken down by trade and type of work, Bidders are to provide the cost of all LABOR & MATERIALS for use as a basis for payment. “

3. RFI- 47 Clarification on Winch- Please remove the cleaning of the historic winch and replacement cost for locating the historic winch on the roof from the scope of work.

END OF ADDENDUM # 3