

Staff Report

- 9 Demolish rear addition, including walls and roof, floor frame to remain as deck frame- **#804 Truman Avenue - Fairbank Construction Inc. (H11-01-1157)**

The house located on #804 Truman Avenue is listed as a contributing resource in the survey. The house is a one story frame structure and was built in 1928. This staff report is for the review of a Certificate of Appropriateness for a request for demolition of a non historic attached addition located on the back of the historic house. The existing addition is not depicted in the Sanborn maps. The plans propose the reuse of the existing floor structure to be used for a proposed new deck. On September 27, 2011 the Commission approved the first reading for demolition.

Staff understands that the request to remove the attached addition constitutes demolition. The criteria when reviewing a Certificate of Appropriateness that request demolition in under Sec. 102-218 of the LDR's;

(a) The historic architectural review commission shall issue a certificate of appropriateness for an application for demolition:

(1) If the subject of the application is a contributing or historic building or structure, then it should not be demolished unless its condition is irrevocably compromised by extreme deterioration or it does not meet any of the criteria of section 102-125(1) through (9).

The Code also establishes, under Sec. 102-1, Definitions, that a historic building or structure means;

any building or structure which, in whole or in any structural part, was built 50 or more years prior to the current date, and which is located in the historic zoning districts of the city or has been designated as a historic building and/or structure.

It is staff's belief that the proposed request can be considered by the Commission since the proposed structure to be demolish is not historic nor can it be consider as a contributing element to the historic house.

Application

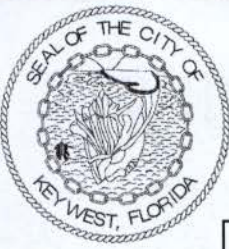

**CITY OF KEY WEST
BUILDING DEPARTMENT
CERTIFICATE OF APPROPRIATENESS**

APPLICATION # 11-01-1157

OWNER'S NAME: Norman + Kristina Turner DATE: 8/29/11

OWNER'S ADDRESS: 804 Truman Ave, Key West PHONE #: 804-384-1560

APPLICANT'S NAME: Fairbank Const. Inc. PHONE #: 292-6584

APPLICANT'S ADDRESS: 516 white st., Key West, FL. 33040

ADDRESS OF CONSTRUCTION: 804 Truman Ave. # OF UNITS: 1

THERE WILL BE A FINAL INSPECTION REQUIRED UNDER THIS PERMIT

DETAILED DESCRIPTION OF WORK: Re-build wood front porch + stair
Remove and replace 6 courses of wood lap siding.
Demolish rear most addition - walls + roof - floor framing to remain
as deck framing

Chapter 837.06 F.S.-False Official Statements – Whoever knowingly makes a false statement in writing with the intent to mislead a public servant in the performance of his or her official duty shall be guilty of a misdemeanor of the second degree punishable as provided for in s. 775.082 or 775.083

This application for Certificate of Appropriateness must precede applications for building permits, right of way permits, variances, and development review approvals. Applications must meet or exceed the requirements outlined by the Secretary of the Interior's Standards for Rehabilitation and Key West's Historic Architectural Guidelines.

Once completed, the application shall be reviewed by staff for completeness and either approved or scheduled for presentation to the Historic Architectural Review Commission at the next available meeting. The applicant must be present at this meeting. The filing of this application does not ensure approval as submitted.

Applications that do not possess the required Submittals will be considered incomplete and will not be reviewed for approval.

Required Submittals

TWO SETS OF SCALED DRAWINGS OF FLOOR PLAN, SITE PLAN AND EXTERIOR ELEVATIONS (for new buildings and additions)
TREE REMOVAL PERMIT (if applicable)
PHOTOGRAPHS OF EXISTING BUILDING (repairs, rehabs, or expansions)
PHOTOGRAPHS OF ADJACENT BUILDINGS (new buildings and additions)
ILLUSTRATIONS OF MANUFACTURED PRODUCTS TO BE USED SUCH AS SHUTTERS, DOORS, WINDOWS, PAINT COLOR CHIPS, AND AWNING FABRIC SAMPLES

Staff Use Only

Date: _____

Staff Approval: _____

Fee Due: \$ _____

Date: 8/29/11

Applicant's Signature: [Signature]

AUG 29 2011
MC 7:10

HISTORIC ARCHITECTURAL REVIEW COMMISSION USE ONLY

Approved _____

Denied _____

Deferred _____

Reason for Deferral or Denial:

HARC Comments:

*Listed as contributing. Built 1928. frame vernacular
Ordinance for demolition.
Guidelines for Front porches, entrances (pages 32-33)
Guidelines for decks (pages 39-40)*

Limit of Work Approved, Conditions of Approval and/or Suggested
Changes:

Date: _____

Signature: _____

Historic Architectural
Review Commission



City Of Key West
Planning Department
3140 Flagler Avenue
Key West, Florida 33040

October 3, 2011

J J Fairbank
Fairbank Contractors
516 White Street
Key West, Florida 33040

**RE: REBUILT FRONT PORCH AND STAIR, REPLACE ROTTED WOOD SIDING WITH SAME AND BUILT DECK ON THE BACK. DEMOLISH REAR ADDITION, INCLUDING WALLS AND ROOF
FOR: #804 TRUMAN AVENUE - HARC APPLICATION # H11-01-1157
KEY WEST HISTORIC DISTRICT**

Dear Mr. Fairbank:

This letter is to notify you that the Key West Historic Architecture Review Commission **approved** the proposed design and the first reading for demolition for the above mentioned project on the public hearing held on Tuesday, September 27, 2011. The Commissioners motioned to approve the project based on the submitted documents and your presentation.

Because this project includes a demolition request, a second reading will take place on October 11, 2011 at Old City Hall, 510 Greene Street. This second reading will be just for the demolition request. Should you have any questions, please do not hesitate to contact me at your convenience.

On behalf of the Historic Architectural Review Commission of our City, thank you for your interest in the preservation of Key West's historic heritage.

Sincerely:

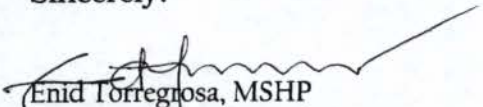
Enid Torregrosa, MSHP
Historic Preservation Planner
City Of Key West
3140 Flagler Avenue
Key West, Florida 33040

305.809.3973

etorregr@keywestcity.com

Sanborn Maps

28

20

38

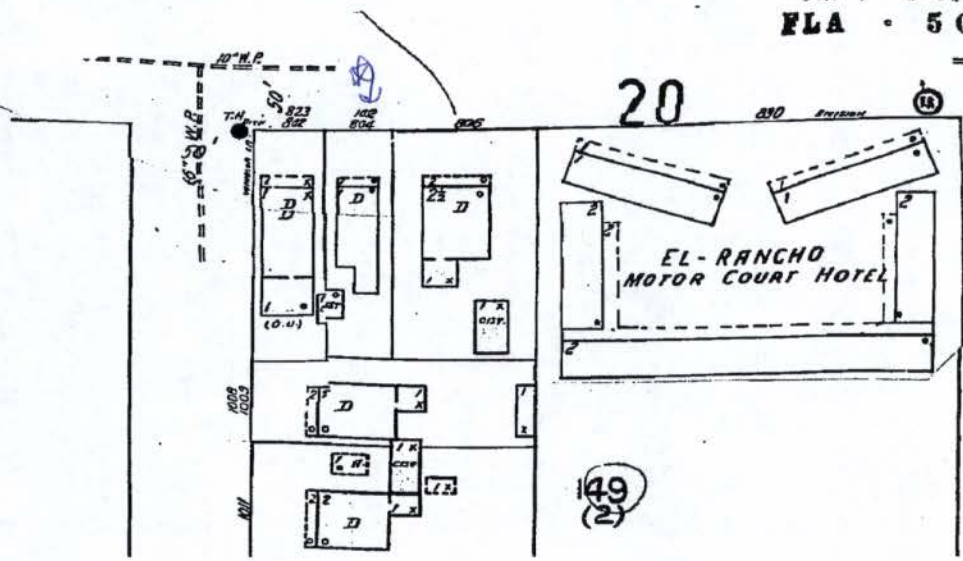

#804 Truman Avenue Sanborn map 1948 copy

Project Photos

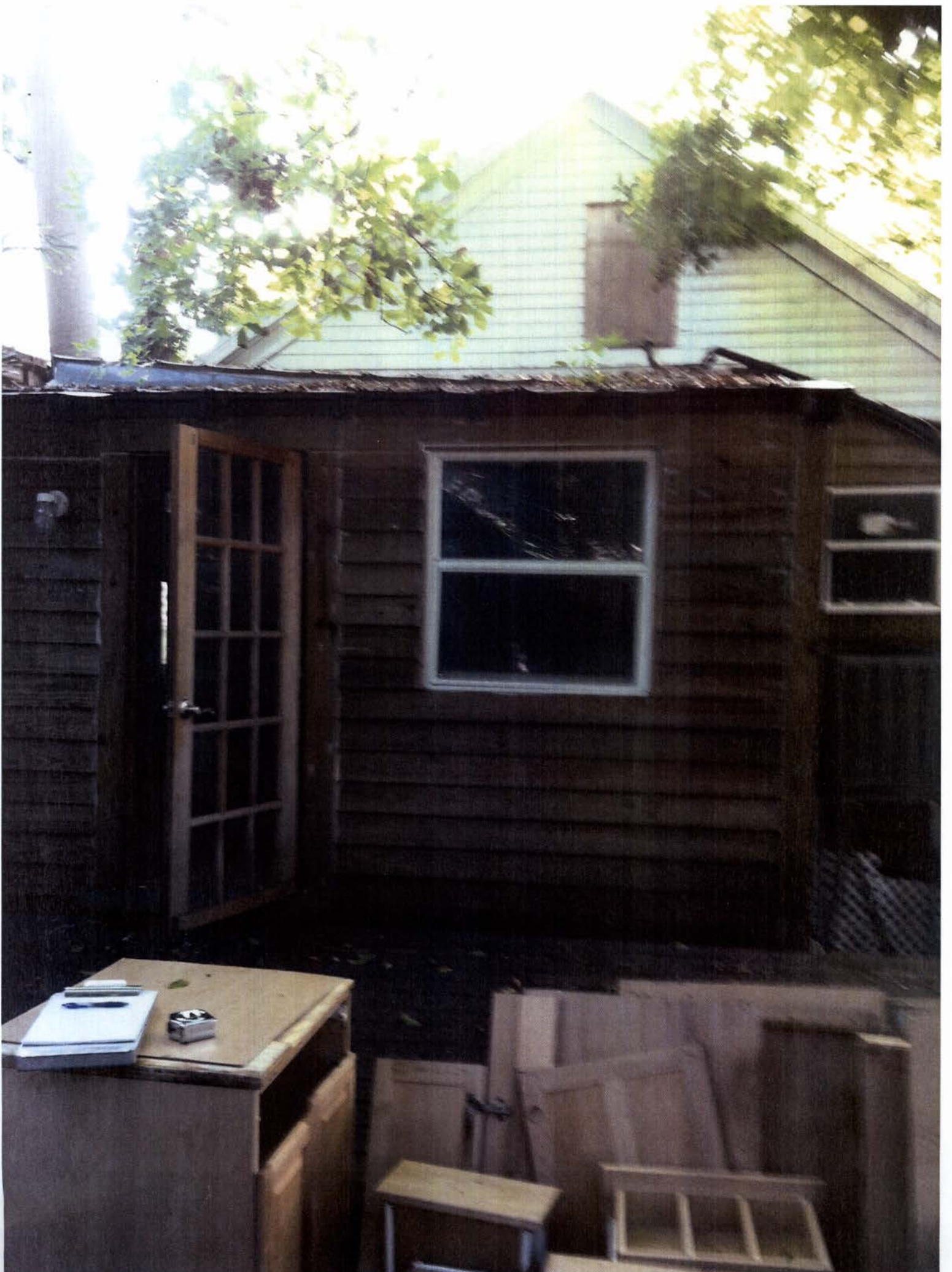

Photo taken by the Property Appraiser's office c1965; 804 Truman Ave.; built 1928;
Monroe County Library





A photograph of a building's exterior showing a large white pipe with red text, a wooden beam, and various other pipes and wires. The pipe has the text "OFFLINE PIPE" visible. The scene is cluttered with various pipes, wires, and a weathered wooden beam.









Site Plans

804 TRUMAN AVENUE

RESIDENTIAL REMODELING PROJECT

804 TRUMAN AVENUE, KEY WEST, FLORIDA 33040

PERMIT SUBMISSION AUGUST 26, 2011

Drawing Index

GENERAL

A0.1.1 - Cover and Index

A0.1.2 - Notes

ARCHITECTURAL

A1.1.1 - Site Plan & Front Elevations

A2.1.1 - First Floor, Framing Plans and
Details



EXISTING FRONT ELEVATION

804 TRUMAN AVE

RESIDENTIAL REMODELING PROJECT

Permit Submission

mbi | k2m
ARCHITECTURE, INC.

1001 Whitehead St., Suite 101, Key West, Florida 33040
Tel: 305-292-7722 | Fax: 305-292-2162
Email: info@mbi-k2m.com | URL: www.mbi-k2m.com
PROF. REG. AA26001059

SUBMISSIONS

2011.08.26 PERMIT SUBMISSION

Project No. MK-11087 Phase: Construction Documents

COVER SHEET

A0.1.1

©2011 by mbi | k2m Architecture, Inc.

DATE: August 26, 2011

Seal:

Consultants:

STRUCTURAL ENGINEER:
David Harrel, P.E.
Harrel Kone Structural Engineers
164D Powers Fort Road,
Building One, Suite 300,
Atlanta, Georgia-30067
404-920-4780

Revisions:

2011.08.26 Permit Submission

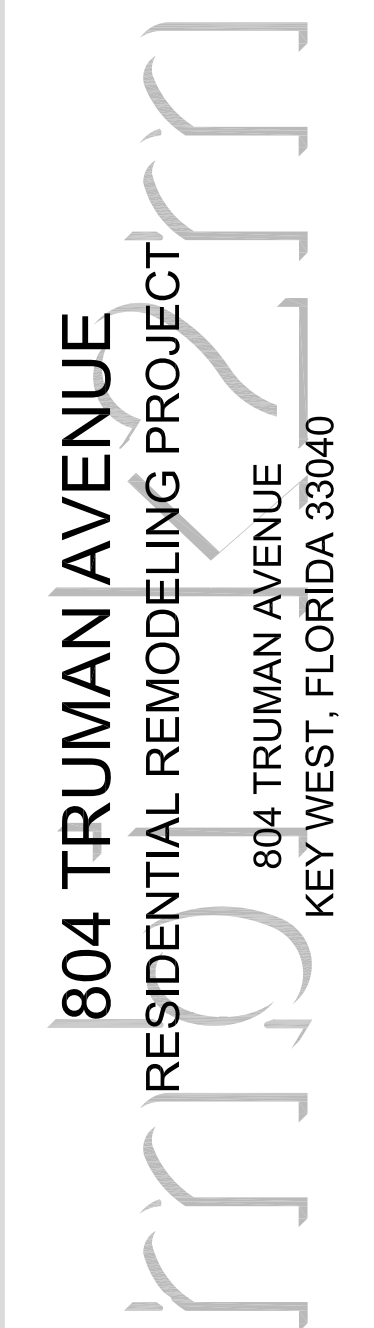

PLOTTED: 8/28/2011 1:24 PM

Drawing Size 24x36	Project #: 11087
Drawn By: ADS	Checked By: MBI

Title:

NOTES

Sheet Number:

A0.1.2

Date: August 26, 2011

©2011 by mbi | k2m Architecture, Inc.

GENERAL NOTES:

CODES, PERMITS, AND REGULATIONS:

- Contractors are responsible for securing all building permits required by local governing authorities.
- Contractors shall meet all local, county, state and federal regulations of demolition, safety, and sanitary precautions during building operations.
- All work shall comply with applicable codes, amendments, rules, regulations, ordinances, laws, orders, approvals, etc., that are required by public authorities. In the event of conflict, the most stringent requirements shall govern. Requirements include, but are not necessarily limited to, the currently applicable editions or publications of the following:
 - Florida Building Code.
 - All local and Municipal Codes.
- Verify field conditions prior to commencement of each portion of the work. Coordinate all site requirements, issues and utilities.

OWNERSHIP OF DRAWINGS AND CONTRACT ITEMS:

- The contract documents are instruments of service and shall remain the property of the architect whether the project for which they are prepared is executed or not. The contract documents are not to be used by the owner for other projects or extensions to the project nor are they to be modified in any manner whatsoever except by agreement in writing and with appropriate compensation to the architect. If copies are required notify the architect.
- The contract documents consist of the following:
 - Drawings and specifications
 - Any and all addenda
- If at any time before commencement of work, or during progress thereof, contractor's methods, equipment or appliances are inefficient or inappropriate for securing quality of work, or rate of progress intended by contract documents, owner may order contractor to improve the quality or increase their efficiency. This will not relieve the contractor of his sureties from their obligations to secure quality or work rate of progress specified in contract.
- The contractor shall coordinate all portions of the work as described in the contract documents. Notify the architect and tenant in writing for resolution of all discrepancies prior to construction.

GENERAL COORDINATION OF DRAWINGS:

- Contractors shall verify that no conflicts exist in locations of proposed walls. Coordinate all mechanical, data, electrical, plumbing and sprinkler equipment to be removed, relocated, or installed (Items to include are all piping, duct work, structural members and conduit; and existing conditions). Verify that all required clearances for installation and maintenance of above equipment are provided. Elements to be exposed or concealed shall be determined and reviewed with owner prior to construction pending.

- Contractors and subs shall coordinate the layout and exact location of all partitions, doors, accessories, electrical / data outlets and light switches with architectural drawings in the field prior to proceeding with construction.
- The finished work shall be firm, well anchored, in true alignment, plumb, level, with smooth, clean, uniform appearances without waves, distortions, hole marks, cracks, stains, or discoloration. Jointing shall be close fitting, neat as well scribed. The finish work shall have no exposed unsightly anchors or fasteners and shall not present hazardous, unsafe corners. All work shall have the provision for expansion, contraction, and shrinkage as necessary to prevent cracks, buckling and warping due to temperature and humidity conditions.
- Attachments, connections, or fastenings of any nature are to be properly and permanently secured in conformance with best practice and the contractor is responsible for providing them accordingly and to these conditions. The drawings show only special conditions to assist contractor. They do not illustrate every detailed connection.
- The contractors are responsible for verifying the dimensions and elevations of existing conditions at the site. The contractors and subs shall coordinate the layout and exact location of all items in the field before proceeding with construction.
- It is the responsibility of the contractors to coordinate and schedule all deliveries and disposal coordination with the owner.
- Each contractor shall check and verify all dimension at the job and shall be responsible for the proper fitting of his/her work there to.
- All existing materials, equipment, and construction are identified on drawings by the words "existing" or "exist". Unless stated otherwise, all notes refer to new materials, equipment, and construction installed under each contract.
- Material indications, notes, and etc. are typical for all contract drawings (uno) unless noted otherwise.
- Align means similar components of construction, i.e. walls, jams, etc. shall be in line across voids.
- These drawings are complementary and interrelated; work of any individual trade is not necessarily confined to specific documents, chapters or locations.
- It is the intent of the contract documents to be designed in accordance with all codes and ordinances in effect at the time the permit is issued. Notify architect immediately upon discovery of suspected deviation.
- Construction techniques, procedures, sequencing and scheduling are solely the responsibility of the contractor.
- DO NOT SCALE DRAWINGS:** use dimensions only. All dimensions must be verified on the job and the architect must be notified of any discrepancies before proceeding with the work.
- It is the intent of the documents and requirements of all contractors to bid and provide a completely waterproof building envelope. Report to architect any condition that would prevent this immediately.
- Coordinate locations and/or elevations of floor drains, registers, grilles, louvers, ducts,

- unit heaters, panels, etc. with mechanical and electrical contractors and architectural drawings.
- Blocking at openings, doors and windows shall be 2x materials. At wall mounted equipment locations, use 1/2" plywood sheet material.
 - Where a detail is shown for one condition, it shall apply to all like or similar conditions, even though not specifically marked on the drawings.

DIMENSIONAL COORDINATION OF DRAWINGS:

- Do not scale drawings; dimensions govern. Verify dimensions with field conditions. If discrepancies are discovered between field conditions and drawings or between drawings, contact the architect for resolution before proceeding.
- Horizontal dimensions indicated are to / from finished face of construction, except as noted.
- Vertical dimensions are from top of floor slab, except where noted to be from above finished floor (a.f.f.).
- Dimensions are not adjustable without approval of the architect unless otherwise noted on drawings.
- Any dimension noted "verify" or "verify in field (vif)" must be reviewed with the architect before beginning construction.
- Dimensions indicated to be "clear" shall be maintained. Any discrepancies or variations in these dimensions shall be reviewed with the architect before proceeding with work in the questionable area.

PATCHING, REPAIR AND CONSTRUCTION:

- Contractors are responsible for and shall provide protection for any existing finishes.
- Cut and fit all new components etc. for alteration of existing conditions and installation of new work. Contractor to patch and repair all disturbed areas to match adjacent materials and finishes.

SCHEDULING ITEMS:

- Contractor shall order and schedule delivery of materials in ample time to avoid delays in construction. If an item is found to be unavailable or have a long lead time, contractor shall notify the architect immediately.

GENERAL DEMOLITION NOTES:

SCOPE OF DEMOLITION

- The existing condition / demolition drawings are intended as a general guide to the demolition required for the project. Demolition is not shown in complete detail and it shall be the responsibility of the demolition contractors to remove existing construction as required to accomplish the new design intent and / or work shown on reasonably implied for the construction of the Project. The Contractor shall refer to the Work shown on all other drawings in the set for the extent of demolition required to perform Work intent.

GENERAL CONDITIONS

- All Contractors are required to visit the job site to verify existing conditions and dimension prior to beginning any work. Notify Architect / Owner as soon as possible of any discrepancies for resolution of the issues(s) prior to beginning of any Work.
- Typical: Demolition Contractor and/or General Contractor are to remove all existing items shown on plans including all mechanical, electrical, plumbing, and fire protection items associated with the demolition.
- Access to the work site is to be coordinated with the Owner.
- The site must remain secure during demolition and construction. Each phase of the project is to be coordinated with Owner.
- Contractor is responsible for removal of all debris; location of dumpsters/trucks shall be coordinated with Owner and City.

HEALTH, SAFETY, AND WELFARE

- The Contractor shall take all necessary precautions during demolition and construction to protect and maintain the integrity and operation of existing or temporary life safety and egress areas required by the local authority governing this project.
- The Contractors are responsible for the removal of all demolition and construction debris generated from work and shall not remain exposed for more than twenty-four (24) hours, taking care to protect overloading the floor assembly and protection of adjacent existing construction and finishes.
- During demolition, the Contractor(s) shall take all precautions necessary to prevent structural damage to the buildings existing walls, or interrupt power and lighting without notification.
- All items indicated to be removed and items not indicated to be reused shall be disposed of properly by the Contractors as agreed upon and directed by the Owner or their Agent in conjunction with building management.

SAFETY AND CONVENIENCE.

SAFETY EQUIPMENT

- The Contractor shall not cause any condition to exist which might be deemed to be hazardous to vehicular traffic, pedestrians, or occupants near or within the premises.
- Building shall be maintained weather proof at all times. In the event of extreme weather events, all openings shall be secured with 3/4" plywood.

SAFE ACCESS BY FEDERAL, STATE, AND LOCAL GOVERNMENT AUTHORITIES

- Authorized representatives of the state, federal, or local government agencies, shall at all times have safe access to the work, and the Contractor shall provide proper facilities for such access and inspection.

PROTECTION OF PROPERTY

- Notify property owners affected by the demolition at least 48 hours in advance of the time demolition begins. During construction operations, maintain conditions, as may be required, to provide access by all tenants. No property unless the Contractor has made special arrangements with the affected persons/property.
- Materials shall be stored on site or in sealed, weatherproof, secure containers. No materials may be left within the building other than the area under renovation.
- Premises shall be cleaned on a daily basis inclusive at area of work and all interior and exterior "paths of travel".
- No smoking is allowed within the building or exterior areas immediately adjacent to property.

ACCESS FOR POLICE AND FIRE

- Notify the Police and Fire Departments before closing any streets. Do not proceed to close street without express permission from these departments.

PROTECTION OF THE ENVIRONMENT

PROTECTION OF SEWERS

- Take adequate measure to prevent the impairment of the operation of the existing storm and sanitary sewer systems. Prevent construction material, pavement, concrete, earth, or other debris from entering a sewer or storm structure.

NOISE CONTROL

- The Contractor shall conduct all his/her work so as to have the least possible affect on neighbors.

Seal:

Consultants:

STRUCTURAL ENGINEER:
David Harrel, P.E.
Harrel Kone Structural Engineers
164D Powers Ferry Road,
Building One, Suite 300,
Atlanta, Georgia-30067
404-920-4780

Revisions:

2011.08.26 Permit Submission

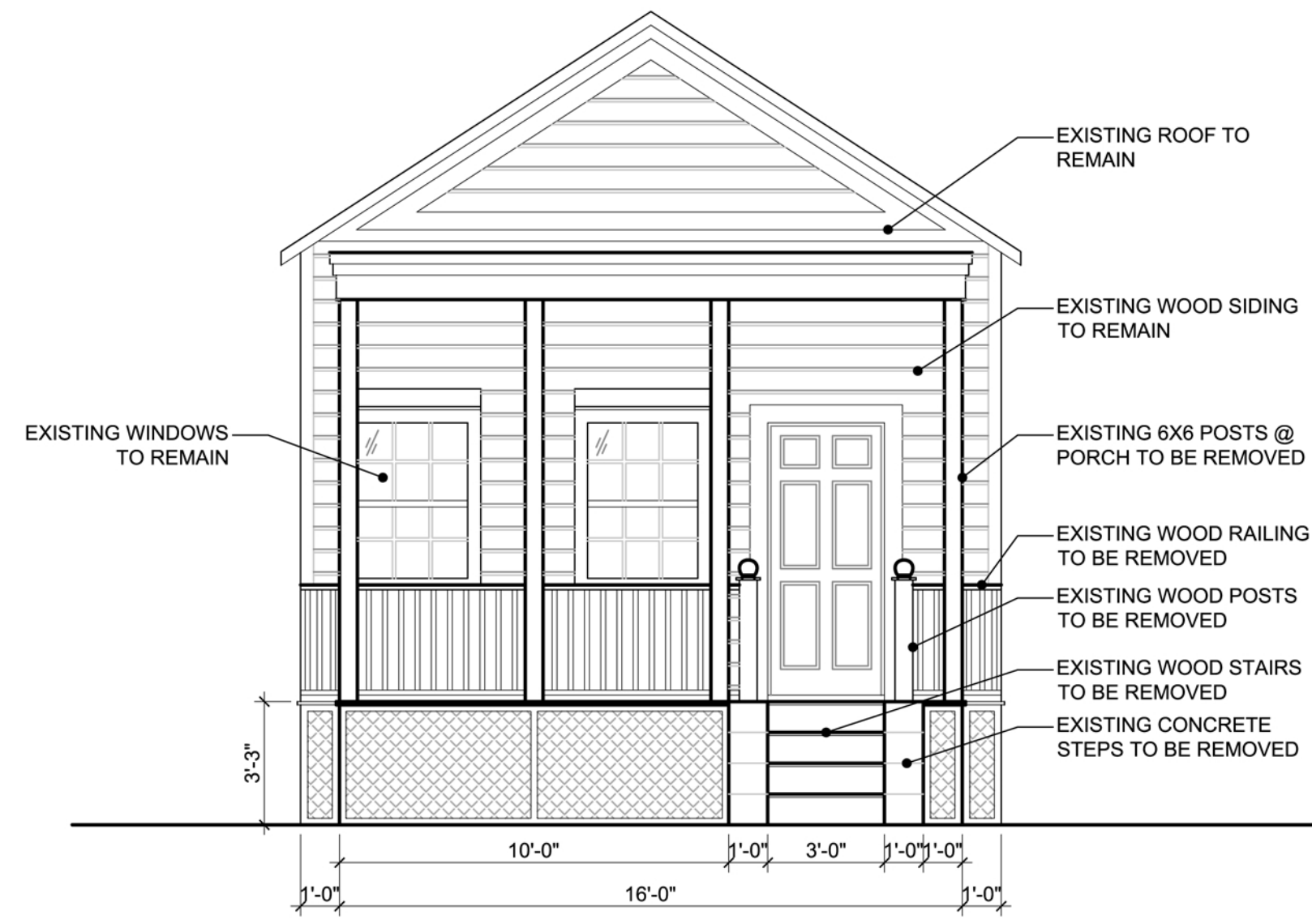

03 EXISTING/DEMOLITION ELEVATION
A1.1.1 SCALE: 1/4"=1'-0" GRAPHIC SCALE: 1/4" = 1'-0"

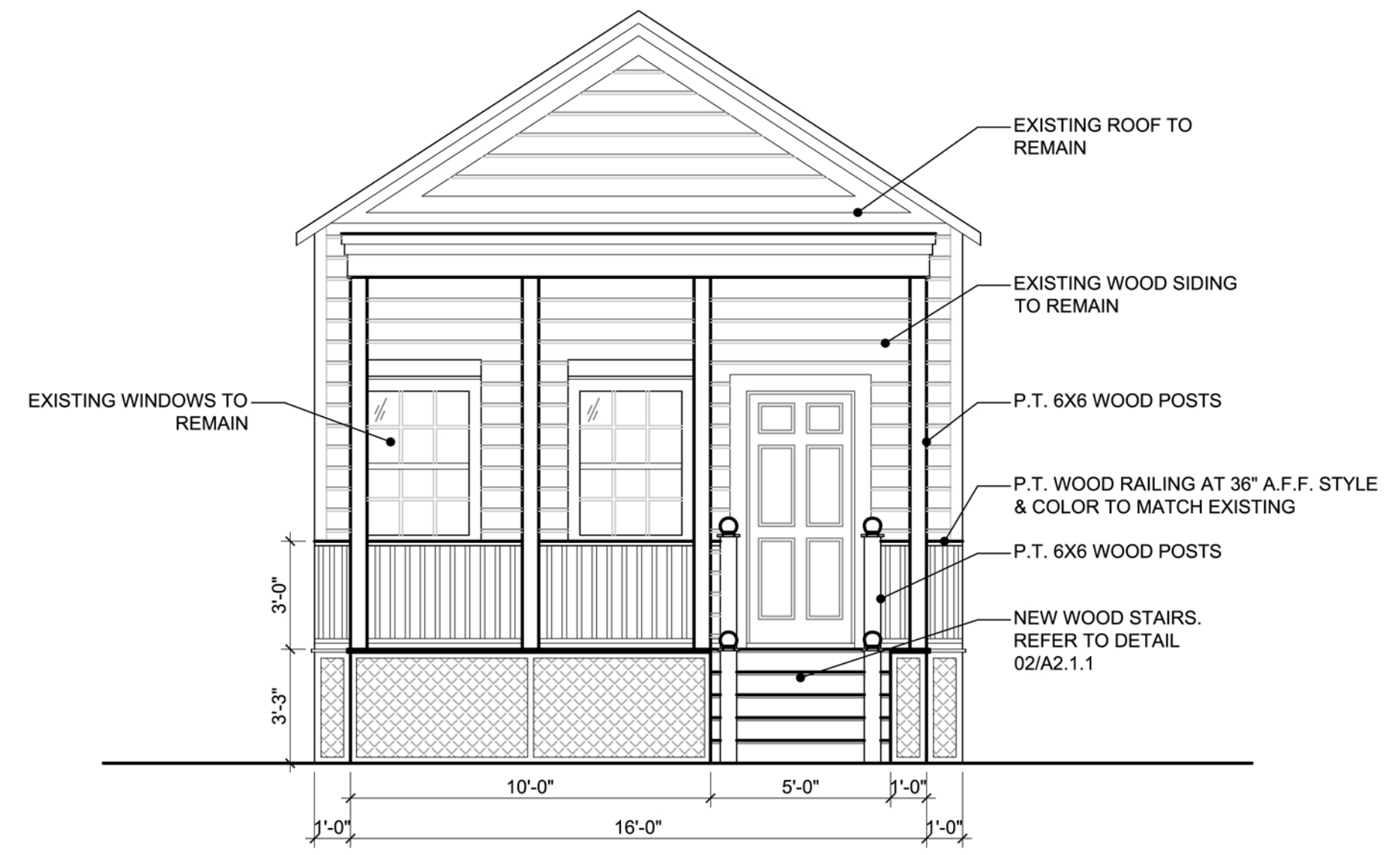

02 PROPOSED ELEVATION
A1.1.1 SCALE: 1/4"=1'-0" GRAPHIC SCALE: 1/4" = 1'-0"

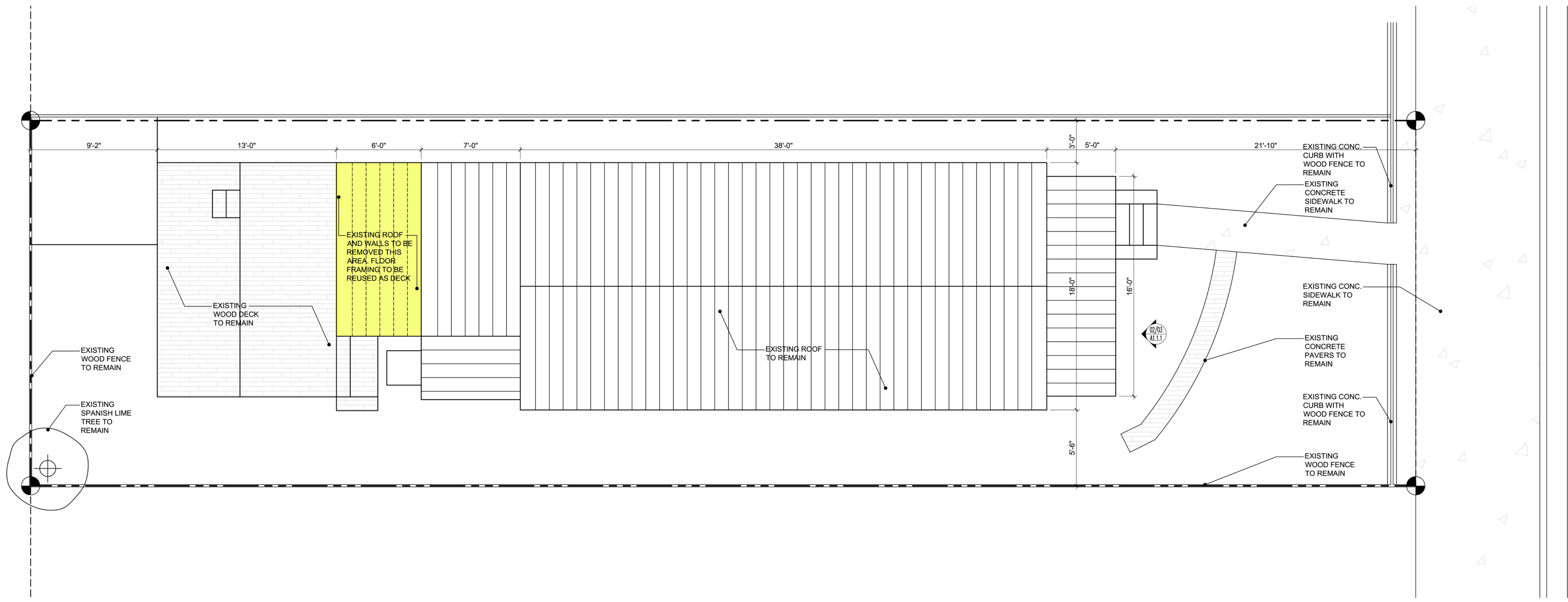

01 SITE AND FIRST FLOOR PLAN
A1.1.1 SCALE: 1/4"=1'-0" GRAPHIC SCALE: 1/4" = 1'-0"

804 TRUMAN AVENUE
RESIDENTIAL REMODELING PROJECT
804 TRUMAN AVENUE
KEY WEST, FLORIDA 33040

PLOTTED: 8/28/2011 1:24 PM
Drawing Size: 24x36 | Project #: 11087
Drawn By: PSS | Checked By: ADS

Title:
SITE PLAN
AND
FRONT ELEVATIONS

Sheet Number:
A1.1.1
Date: August 26, 2011
©2011 by mbi | k2m Architecture, Inc.

Seal:

Consultants:

STRUCTURAL ENGINEER:
David Harrel, P.E.
Harrel Kone Structural Engineers
164D Powers Fort Road,
Building One, Suite 300,
Atlanta, Georgia-30067
404-920-4780

Revisions:

2011.08.26 Permit Submission

804 TRUMAN AVENUE
RESIDENTIAL REMODELING PROJECT
804 TRUMAN AVENUE
KEY WEST, FLORIDA 33040

PLOTTED: 8/26/2011 1:24 PM

Drawing Size	Project #:
24x36	11087
Drawn By:	Checked By:
PSS	ADS

Title:
**FIRST FLOOR
FRAMING PLAN
AND
DETAILS**

Sheet Number:

A2.1.1

Date: August 26, 2011

©2011 by mbi | k2m Architecture, Inc.

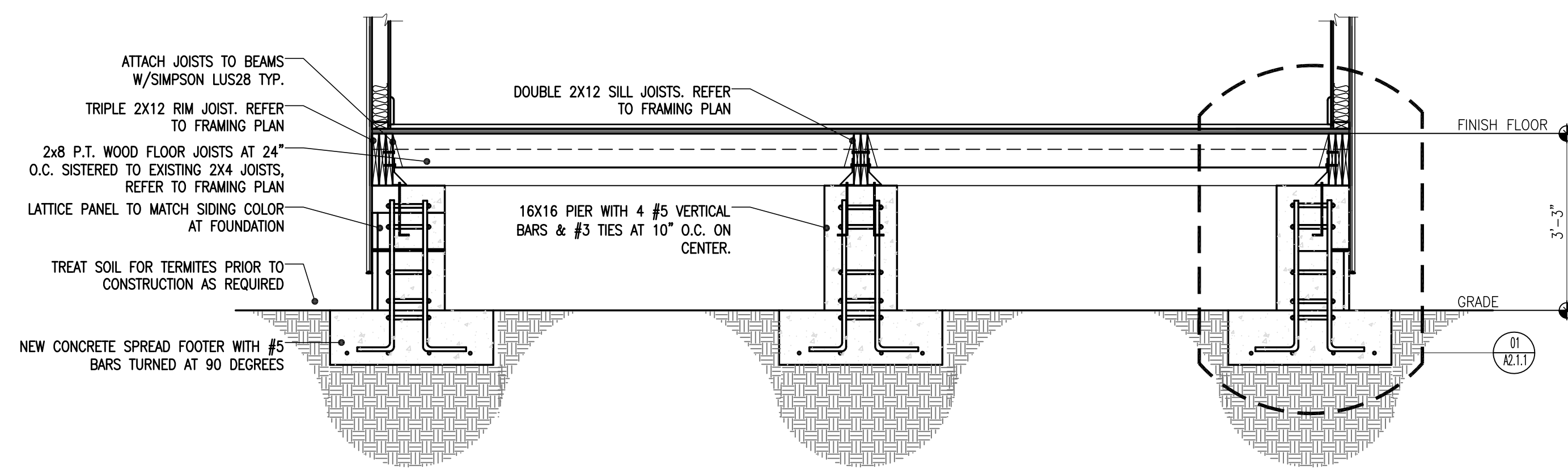

04
A2.1.1 FOUNDATION SECTION
SCALE: 1/2"=1'-0"

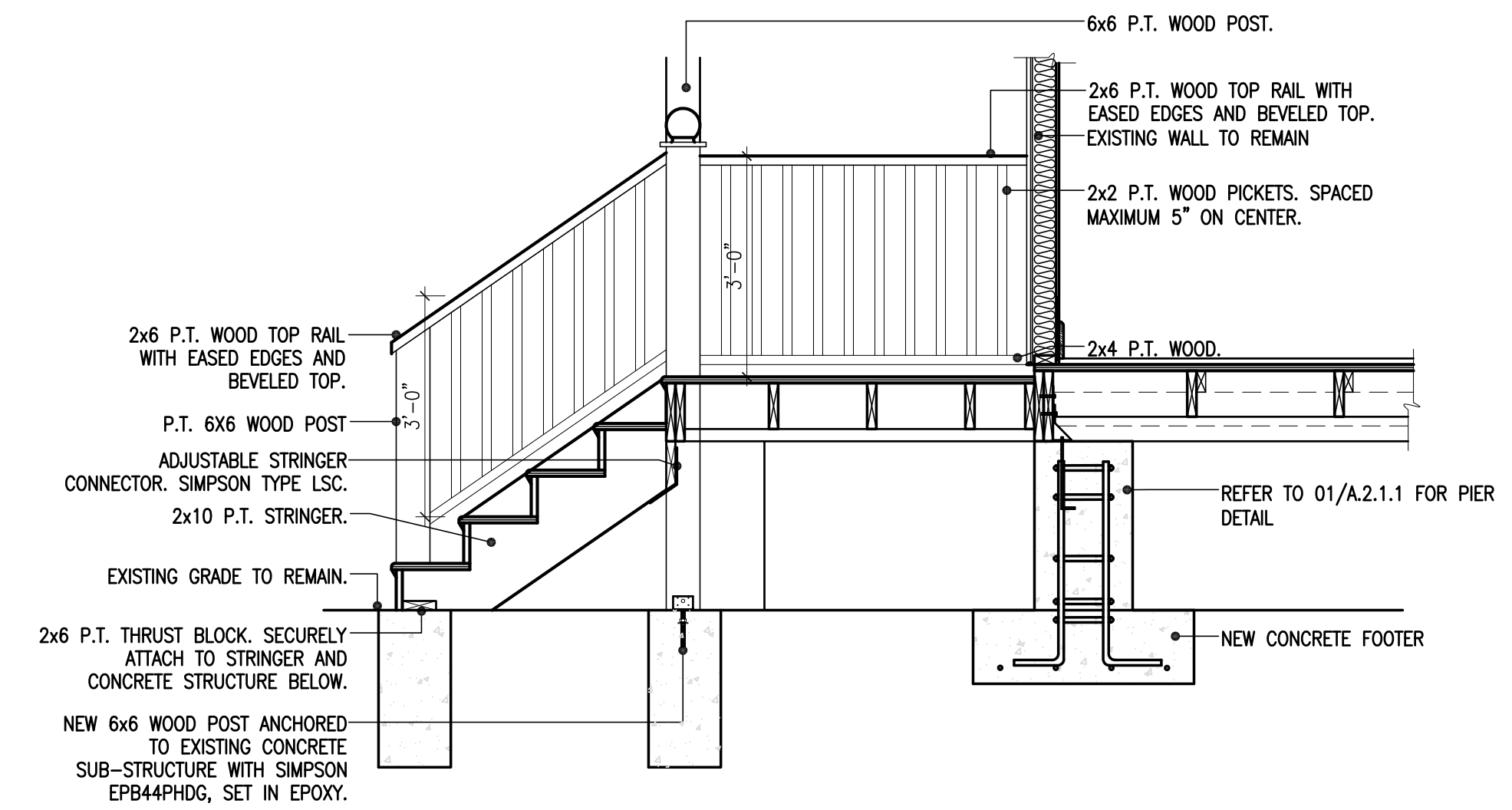
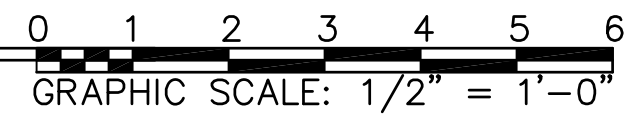

02
A2.1.1 STAIR DETAIL
SCALE: 1/2"=1'-0"

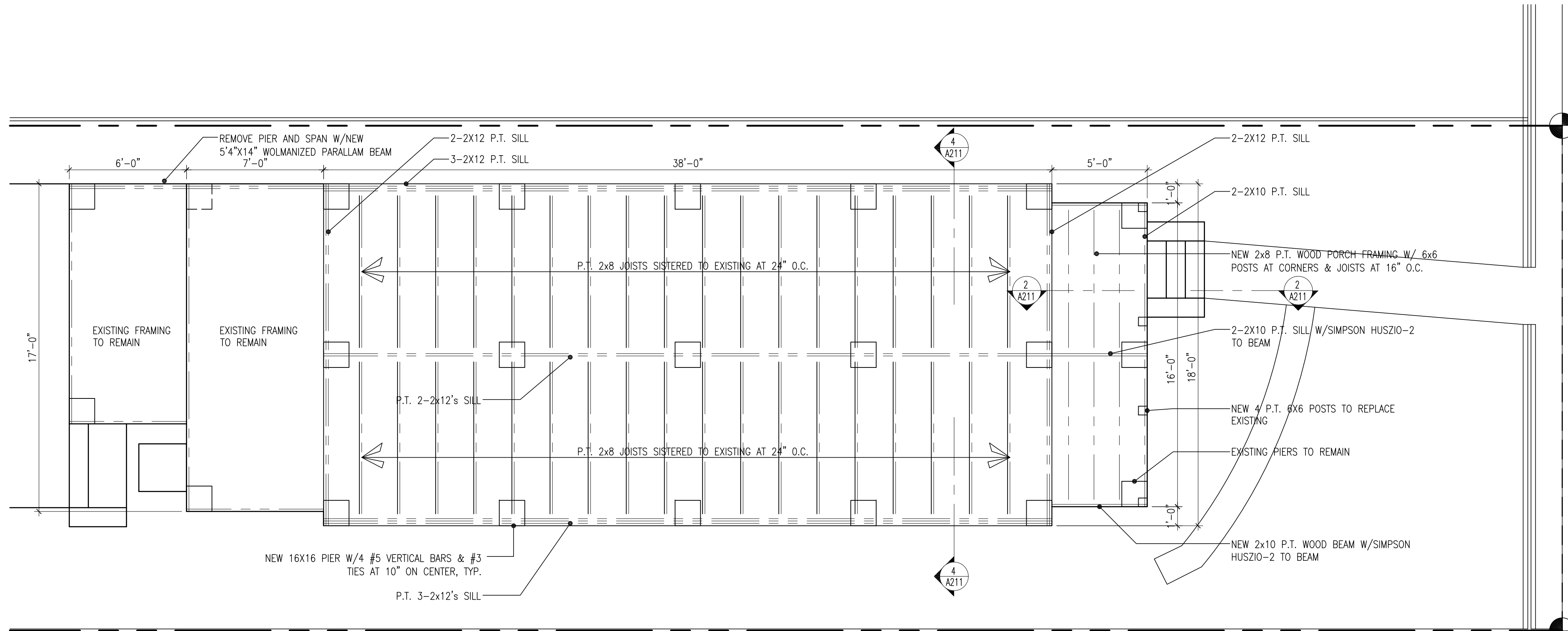
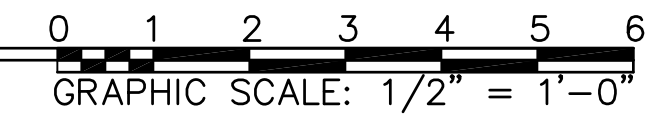

NOTES:
1. PROVIDE SHORING FOR EXISTING ROOF AND WALLS DURING CONSTRUCTION.
2. ALL NEW WOOD FRAMING SHALL BE SYP#Z.

03
A2.1.1 FIRST FLOOR FRAMING PLAN
SCALE: 1/4"=1'-0"

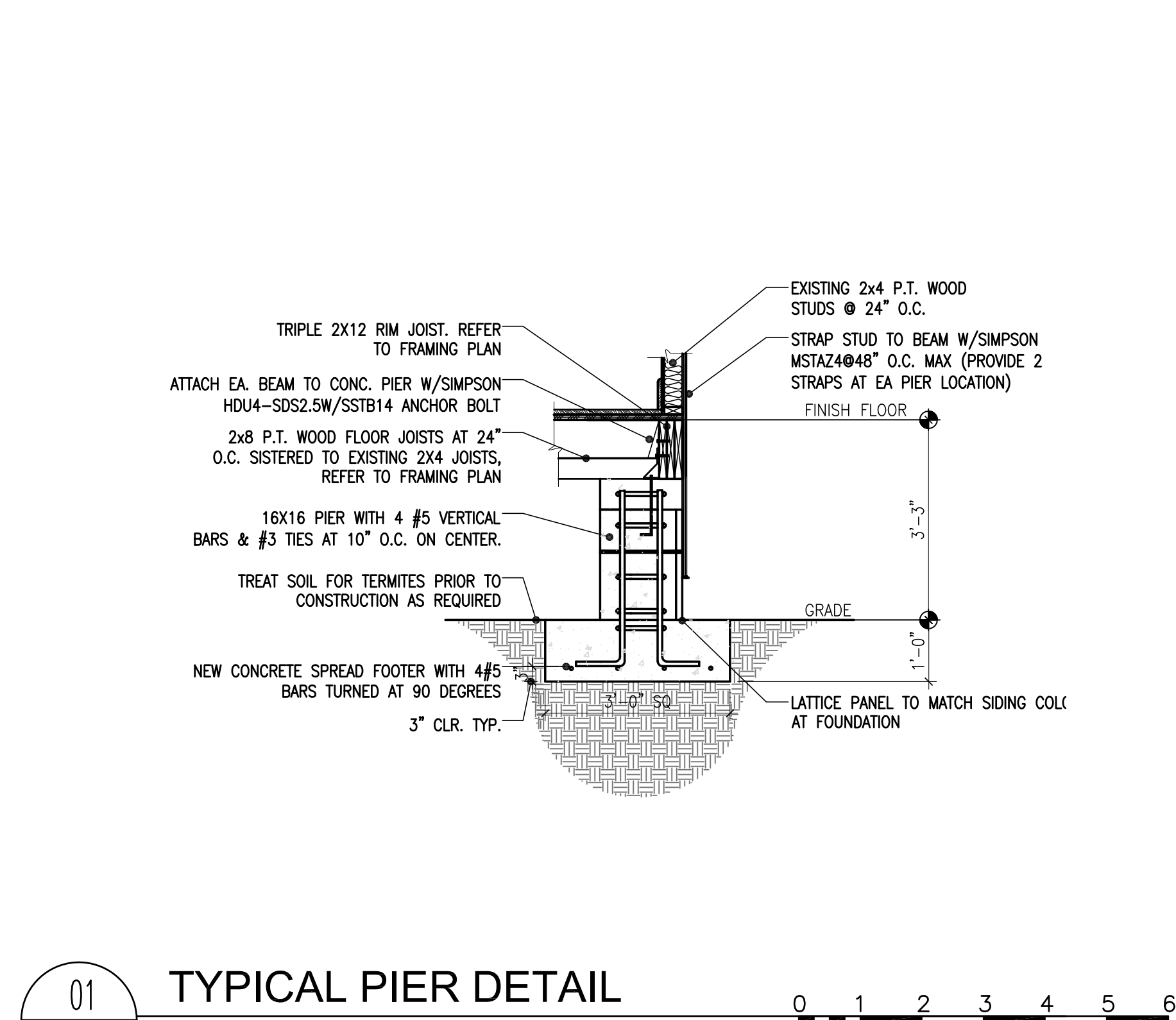
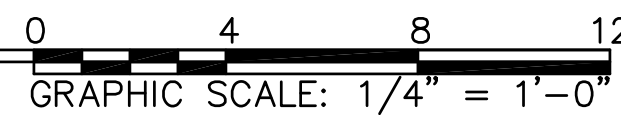

01
A2.1.1 TYPICAL PIER DETAIL
SCALE: 1/2"=1'-0"

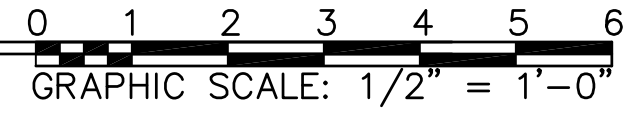

P:\2011\11087 - 804 Truman Avenue\804A2.1.1.dwg, 8/26/2011 1:24 PM, scale: 1/2" = 1'-0", author: g. wynn

Noticing

Public Meeting Notice

The Historic Architectural Review Commission will hold a public hearing at 3:00 p.m., September 27, 2011 at Old City Hall, 510 Greene Street, Key West, Florida. The purpose of the hearing will be to consider a request for:

DEMOLITION OF REAR ADDITION, INCLUDING WALLS

#617 Mickens Lane

Applicant: Michael Skoglund- Application # H11-01-855

If you wish to see the application or have any questions, you may visit the Planning Department during regular office hours at 3140 Flagler Avenue call 809-3973 or visit our website at www.keywestcity.com .

**Property Appraiser
Information**

Karl D. Borglum
Property Appraiser
Monroe County, Florida

office (305) 292-3420
fax (305) 292-3501
Website tested on
Internet Explorer

**GIS Mapping requires Adobe Flash 10.3 or higher.
(An Export Map widget is in the lower left corner.)**

Property Record View

Alternate Key: 1030848 Parcel ID: 00030080-000100

Ownership Details

Mailing Address:
TURNER NORMAN AND KRISTINA
564 OSPREY RD
CARDINAL, VA 23025-2012

Property Details

PC Code: 01 - SINGLE FAMILY
Millage Group: 10KW
Affordable Housing: No
Section-Township-Range: 06-68-25
Property Location: 804 TRUMAN AVE KEY WEST
Subdivision: Tropical Building and Investment Co Sub
Legal Description: PT LT 1 SQR 2 TR 12 KW TROPICAL SUB PB1-37 OR615-642 OR2234-1776/77 OR2370-2246/47 OR2466-2023/24 OR2526-2044/45

Parcel Map (Click to open dynamic parcel map)

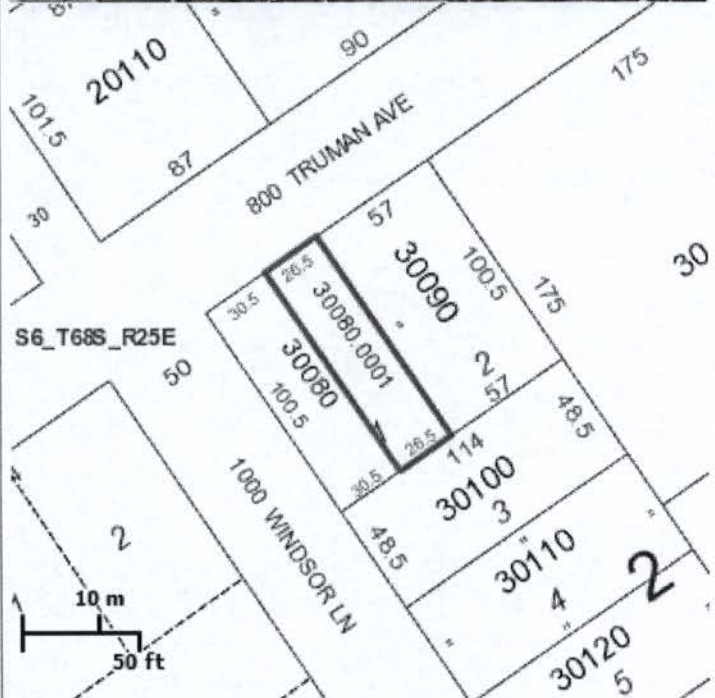

Land Details

Land Use Code	Frontage	Depth	Land Area
010D - RESIDENTIAL DRY	27	101	2,663.00 SF

Building Summary

Number of Buildings: 1
 Number of Commercial Buildings: 0

Total Living Area: 882
Year Built: 1928

Building 1 Details

Building Type R1
Effective Age 27
Year Built 1928
Functional Obs 0

Condition A
Perimeter 138
Special Arch 0
Economic Obs 0

Quality Grade 450
Depreciation % 33
Grnd Floor Area 882

Inclusions: R1 includes 1 3-fixture bath and 1 kitchen.

Roof Type GABLE/HIP

Heat 1 FCD/AIR DUCTED

Heat Src 1 ELECTRIC

Roof Cover METAL

Heat 2 NONE

Heat Src 2 NONE

Foundation CONC BLOCK

Bedrooms 2

Extra Features:

2 Fix Bath 0
3 Fix Bath 0
4 Fix Bath 0
5 Fix Bath 0
6 Fix Bath 0
7 Fix Bath 0
Extra Fix 0

Vacuum 0
Garbage Disposal 0
Compactor 0
Security 0
Intercom 0
Fireplaces 0
Dishwasher 0

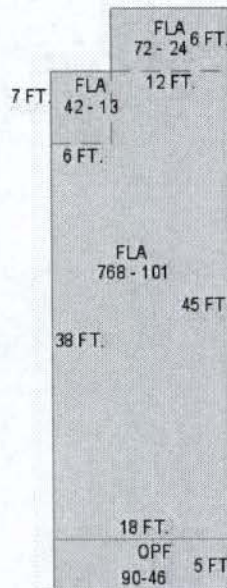

Sections:

Nbr	Type	Ext Wall	# Stories	Year Built	Attic A/C	Basement %	Finished Basement %	Area
0	FLA	12:ABOVE AVERAGE WOOD	1	2008	Y			72
0	FLA	12:ABOVE AVERAGE WOOD	1	2008	Y			42
1	OPF		1	1928		0.00	0.00	90

2	FLA	12:ABOVE AVERAGE WOOD	1	1928	N	Y	0.00	0.00	768
---	-----	-----------------------	---	------	---	---	------	------	-----

Misc Improvement Details

Nbr	Type	# Units	Length	Width	Year Built	Roll Year	Grade	Life
0	WD2:WOOD DECK	252 SF	18	14	2008	2009	2	40
1	FN2:FENCES	104 SF	26	4	1983	1984	2	30
2	PT3:PATIO	45 SF	0	0	1964	1965	2	50

Appraiser Notes

2008-7-3 MLS \$575,000 2/1 SWEET 2BR CONCH COTTAGE ZONED HNC-1 X FLOOD ZONE
2005-05-13 ASKING \$869,000 2BD/1BA 930SF FROM SALAZAR SELLS-SKI

Building Permits

Bldg Number	Date Issued	Date Completed	Amount	Description	Notes
8-899	03/28/2008	07/09/2008	2,300		REPLACE 2 FRONT WINDOWS W DBL HUNG + WOOD SHUTTERS
10-0224	01/28/2010	02/25/2011	5,000		REMOVE 6 NON CONFORMING WINDOWS AND REPLACE WITH 6 WOOD 6X6 WINDOWS 2 ON FRONT, 2 ON EACH SIDE, INSTALL CORRUGATED ALUMINUM SHUTTERS

Parcel Value History

Certified Roll Values.

[View Taxes for this Parcel.](#)

Roll Year	Total Bldg Value	Total Misc Improvement Value	Total Land Value	Total Just (Market) Value	Total Assessed Value	School Exempt Value	School Taxable Value
2011	80,530	3,402	224,609	308,541	308,541	0	308,541
2010	91,571	290	191,337	283,198	283,198	0	283,198
2009	101,798	290	244,858	346,946	346,946	0	346,946
2008	94,543	290	345,738	440,571	440,571	0	440,571
2007	171,591	290	276,952	448,833	448,833	0	448,833
2006	165,288	290	239,670	405,248	103,491	25,000	78,491
2005	170,149	290	159,780	330,219	100,477	25,000	75,477
2004	90,746	290	159,780	250,816	97,550	25,000	72,550
2003	136,119	290	55,923	192,332	95,732	25,000	70,732
2002	121,698	290	55,923	177,911	93,489	25,000	68,489
2001	95,736	301	55,923	151,960	92,017	25,000	67,017
2000	80,677	149	45,271	126,096	89,337	25,000	64,337
1999	70,079	139	45,271	115,490	86,989	25,000	61,989
1998	69,737	147	45,271	115,155	85,620	25,000	60,620

1997	68,370	154	39,945	108,469	84,189	25,000	59,189
1996	42,048	100	39,945	82,092	81,737	25,000	56,737
1995	42,048	105	39,945	82,097	79,744	25,000	54,744
1994	37,604	99	39,945	77,648	77,648	25,000	52,648
1993	37,604	104	39,945	77,653	77,653	25,000	52,653
1992	37,604	109	39,945	77,657	77,657	25,000	52,657
1991	37,604	114	39,945	77,663	77,663	25,000	52,663
1990	34,797	119	31,290	66,206	66,206	25,000	41,206
1989	18,410	0	30,625	49,035	49,035	25,000	24,035
1988	16,075	0	23,967	40,042	40,042	25,000	15,042
1987	15,872	0	19,174	35,046	35,046	25,000	10,046
1986	15,960	0	19,174	35,134	35,134	25,000	10,134
1985	15,466	0	12,044	27,510	27,510	25,000	2,510
1984	14,430	0	12,044	26,474	26,474	25,000	1,474
1983	14,430	0	12,044	26,474	26,474	25,000	1,474
1982	14,720	0	11,241	25,961	25,961	25,000	961

Parcel Sales History

NOTE: Sales do not generally show up in our computer system until about two to three months after the date of sale. If a recent sale does not show up in this list, please allow more time for the sale record to be processed. Thank you for your patience and understanding.

Sale Date	Official Records Book/Page	Price	Instrument	Qualification
7/13/2011	2526 / 2044	283,000	WD	02
4/23/2010	2466 / 2023	222,000	WD	02
8/31/2006	2234 / 1776	450,000	WD	Q
2/1/1975	615 / 642	12,500	00	Q

This page has been visited 116,896 times.

Monroe County Property Appraiser
 Karl D. Borglum
 P.O. Box 1176
 Key West, FL 33041-1176