

ESTIMATE FOR CONTRACT

DATE: April 27, 2026

CONTRACT TITLE:

Conch Republic Seafood Replace Main Roof/Wall Cladding

Revisions/Comments

Direct Materials/Eqt Rentals			54,242.27	
Markup on Materials/Eqt Rentals	15.00%	15.00%	8,136.94	
Direct Labor			298,712.00	
Subs			1,350,907.30	
Markup on Subs	10.00%	10%	135,090.73	
<b>SUBTOTAL</b>				1,847,088.64
Mobilization				62,000.00
Permit				84,000
Allowance only to be used with owners written				100,000
<b>GRAND TOTAL</b>				<b>2,093,088.64</b>

Contractor name: Sea Tech of the Florida Keys Inc

Signature & Title of Preparer: \_\_\_\_\_

April 27, 2026

Date:

BREAKDOWN OF DIRECT COSTS								
ITEMS OF WORK	QTY	UNIT	MATERIAL/EQT RENTAL		LABOR		SUBCONTRACTORS	
			Unit Cost	Total Cost	Unit Cost	Total Cost	Rate	Total
Superintendent (16 weeks)	640	hrs	-	-	75.00	48,000.00	-	-
Foreman (16 weeks)	640	hrs	-	-	65.00	41,600.00	-	-
Laborer (2 @ 16 weeks)	1280	hrs	-	-	35.00	44,800.00	-	-
Clerical (2 hours per week)	40	hrs	-	-	35.00	1,400.00	-	-
Plumber - Fire Protection								
Secure/Manage Fire Sprinkler System on daily basis (2 techs 4 hrs/day @ 72 days)	288	hrs	-	-	154.00	44,352.00	-	-
HVAC/Mechanical (2 @ 1 week)	80	hrs	-	-	182.00	14,560.00	-	-
Carpenter (4 @ 13 weeks)	2080	hrs	-	-	50.00	104,000.00	-	-
Temporary Walls - Construction Zones	1	ls	2,860.43	2,860.43	-	-	0	-
Telescopic Forklift	4	mo	4,528.11	18,112.44	-	-	0	-
Manlift rental	4	mo	4,380.95	17,523.80	-	-	-	-
Steel Fabrication - Dowling	1	ls	-	-	-	-	267,277.00	267,277.00
Roof Decking/Wall Cladding								
Barndominiums	1	ls	-	-	-	-	676,540.00	676,540.00
TPO Roof - Gary the Carpenter	1	ls	-	-	-	-	329,798.00	329,798.00
Electrical - Tomkins Electric	1	ls	-	-	-	-	56,430.00	56,430.00
Grease Box Materials	1	ls	119.78	119.78	-	-	-	-
Plenum Materials	1	ls	3,974.34	3,974.34	-	-	-	-
Paint - DTM - existing steel	15	gal	85.99	1,289.85	-	-	-	-
2 - 40 ft storage containers delivery charges - storing restaurant merchandise	1	ls	3,827.00	3,827.00	-	-	-	-
2 - 40 ft storage containers per month storing restaurant merchandise	4	mo	403.66	1,614.64	-	-	-	-
20 yd dumpster	6	ea	820.00	4,920.00	-	-	-	-
Metal Supplier Increase effective 5/22/26, increase at 10% for materials, Barndominiums & Dowling	1	ea	-	-	-	-	20,862.30	20,862.30
<b>TOTALS</b>				54,242.27		298,712.00		1,350,907.30



## Delivery

Delivering to 33040 (9 items)

---

### HDX

#### 20 ft. x 100 ft. Clear 6 mil Plastic Sheeting

Sheet Length (ft.): 100 ft

Sheet Width (ft.): 20 ft

Color Family: Clear

Pickup at Key West

Delivering to 33040

Check Nearby Stores

Order within 7 hrs 43 mins to get it by Tomorrow

\$508.00

(\$127.00/item)

Get Bulk Pricing of \$99.00 on this item when you purchase at least 6 units.

---

### Simpson Strong-Tie

#### 1/4 in. x 3 in. Strong-Drive SDS Heavy-Duty Connector Screw (25-Pack)

Screw Length: 3 in

Size: 1/4 in

Package Quantity: 25

Pickup at Key West

Delivering to 33040

Check Nearby Stores

Get it delivered as soon as tomorrow. Schedule your delivery in checkout.

\$136.70

(\$13.67/item)

Get Bulk Pricing of \$12.30 on this item when you purchase at least 12 units.

---

### WeatherShield

#### 2 in. x 4 in. x 16 ft. 2 Prime Ground Contact Pressure-Treated Southern Yellow Pine

Lumber

Nominal Product Length (ft.): 16 ft

Color/Finish: Brown

Pickup at Key West

Delivering to 33040

Check Nearby Stores

Get it delivered as soon as tomorrow. Schedule your delivery in checkout.

\$687.60

(\$15.28/item)

Get Bulk Pricing of \$13.75 on this item when you purchase at least 100 units.

---

**Grip-Rite**

**3 in. x 0.120 in. 21° Plastic Collated Exterior Galvanized Ring Shank Round Head**

**Framing Nails 1000 per Box**

Nail Gauge: NA

Nail Angle: 21 degree

Package Quantity: 1000

Fastener Length (in.): 3.00

Pickup at Key West

Delivering to 33040

Check Nearby Stores

Get it delivered as soon as tomorrow. Schedule your delivery in checkout.

\$284.88

(\$47.48/item)

---

**1/2 in. x 4 ft. x 8 ft. CDX Ground Contact Pressure-Treated Pine Plywood**

Store SKU #1001754124

Model #131876

Pickup at Key West

Delivering to 33040

Check Nearby Stores

Get it delivered as soon as tomorrow. Schedule your delivery in checkout.

\$1,043.50

(\$41.74/item \$46.38)

**Your Order**

Subtotal

\$2,660.68

Pickup

FREE

Estimated Sales Tax\*

\$199.55

Total \$2,860.43

Four Star Rentals - KW  
 305 294-7171 Fax 292-4808  
 5216 Overseas Highway  
 Key West, FL 33040

QUOTE# 15608

DATE/TIME IN:

DATE/TIME OUT: 06/01/2026 9.00 AM

**RENTED AND/OR SOLD TO**

Account #: SEATEC  
 SEA TECH INC.  
 OF THE FLORIDA KEYS  
 PO BOX 420529  
 SUMMERLAND KEY , FL 33042-0529

Quote

**ADDRESS AT WHICH EQUIPMENT WILL BE USED**  
 SEA TECH INC.  
 OF THE FLORIDA KEYS  
 PO BOX 420529  
 SUMMERLAND KEY, FL 33042-0529

Delivery Date: 06/01/2026 Time: 9.00 AM -10.00 AM  
 Pickup Date: 06/29/2026 Time: 9.00 AM

305-872-0888

WRITTEN BY	CHECKED IN BY	AUTHORIZED RENTER	JOB LOCATION
ODONE			
CAR LICENSE NO.	DRIVER'S LICENSE NUMBER	P.O. NO. OR JOB NO.	DATE AND TIME DUE IN
	T520556524XXXXX		06/29/2026 9.00 AM

**ITEMS RENTED AND/OR SOLD**

Item #	Description	Quantity	Rates	M	W	D	H	Date&Time Due	Amount
TT-13004	FORKI FT GTH 844 ( TELEHANDLER)	1	4WK 3999.99	1				06/29/2026 9.00 AM	3999.99

599.99 Minimum 659.99 SDY 659.99 24 Hrs 1599.99 1 Week 3999.99 4 Wks

Serial# GTH0812-16340

**DIESEL FUEL ONLY. 8,000 LBS CAPACITY DO NOT OVERLOAD, NEVER USE AROUND POWERLINES OR STAND ON FORKS. DO NOT OPERATE OVER OTHER PERSONNEL OR DRIVE WITH LOAD EXTENDED. READ PLACARDS & OPERATORS MANUAL!**

Thank you for choosing Four Star Rentals. We appreciate your business.  
 INVOICES ARE DUE UPON RECEIPT

Total Rental	3999.99
Environmental Fee	40.00
Delivery/Pickup	175.00
Subtotal	4214.99
Sales Tax (ST)	313.12
Total	4528.11
Security Required	0.00

\*\*\*\*\*STOP\*\*\*\*\*

This is NOT an INVOICE. DO NOT PAY THIS COPY. An invoice will be issued upon RETURN. By signing this you agree to the terms THANK YOU!

Four Star Rentals - KW  
 305 294-7171 Fax 292-4808  
 5216 Overseas Highway  
 Key West, FL 33040

CONTRACT# 263650 INVOICE# 366098

DATE/TIME IN: 07/07/2025 4:58 PM

DATE/TIME OUT: 06/09/2025 9.00 AM

Closed Contract/Invoice

RENTED AND/OR SOLD TO  
 Account #: SEATEC  
 SEA TECH INC.  
 OF THE FLORIDA KEYS  
 PO BOX 420529  
 SUMMERLAND KEY , FL 33042-0529

ADDRESS AT WHICH EQUIPMENT WILL BE USED  
 SEA TECH INC.  
 1100 SIMONTON ST  
 KEY WEST, FL 33040  
 CALL # 305-748-7191

Delivery Date: 06/09/2025 Time: 9.00 AM -10.30 AM  
 Pickup Date: 07/07/2025 Time: 9.00 AM -10.00 AM

305-872-0888

WRITTEN BY ODONE	CHECKED IN BY ERIK	AUTHORIZED RENTER	JOB LOCATION KEY WEST
CAR LICENSE NO. RYAN	DRIVER'S LICENSE NUMBER T520556524XXXXX	P.O. NO. OR JOB NO. GATO BUILDING	DATE AND TIME DUE IN See Details Below

ITEMS RENTED AND/OR SOLD

Item #	Description	Qty Out / In	Rates	M	W	D	H	Date&Time In	Amount
CE-463-02	LIFT, 45/25 SELF PROP, GENIE ARTI-BOOM	0 1	4WK 3799.99				7.58	07/07/2025 4:58 PM	3799.99
Serial# Z-45-004949									
Quantity Rtn/AmtChgd: 1/ 3799.99									
SF-101-00	SAFETY HARNESS	0 2	4WK 24.99				7.58	07/07/2025 4:58 PM	49.98
Serial# ELK RIVER 55102 2/99									
Quantity Rtn/AmtChgd: 2/ 49.98									
SF-103-00	SAFETY LANYARD	0 2	4WK 19.99				7.58	07/07/2025 4:58 PM	39.98
Quantity Rtn/AmtChgd: 2/ 39.98									

Thank you for choosing Four Star Rentals. We appreciate your business.  
 INVOICES ARE DUE UPON RECEIPT

DAMAGE WAIVER CHARGE (DWC) 10%

DWC IS NOT INSURANCE.

Total Rental	3889.95
Environmental Fee	38.00
Delivery/Pickup	150.00
Subtotal	4077.95
Sales Tax (ST)	303.00
Total	4380.95
Less Deposit	0.00
Balance Due	4380.95
Amount Posted To A/R	4380.95





Entity of PowerHouse Management and Consulting CBC1266756

Date: 2/12/2026

Bill to: Ryan (Seatech)

Job Site: Conch Republic Seafood Company  
631 Greene St. Key West, Fl. 33040

**Description:**

- Replace existing steel decking. New decking to be 1.5c gage 18 w/G90 galvanized finish, WMP-50 insulation as required  
Labor \$338,620.00  
Materials \$145,790.00
- Replace remaining wall cladding and z-channel on north wall near kitchen  
Labor \$46,710.00  
Materials \$17,820.00
- Replace purlins/PBR roof deck at Gift Shop  
Labor \$39,060.00  
Materials \$24,295.00
- Replace wall cladding and z-channel at Gift Shop/entrance.  
Labor \$46,710.00  
Materials \$17,535.00
- Approximately 12 weeks for completion, all work will be scheduled at night to limit disruption to restaurant.

\*Price includes Material and Labor\*\*

**TOTAL: \$676,540.00**

\*Price does not include cost of engineering and plans, and permit Fees

\* All checks are to be made out to **Powerhouse Management and consulting**

Powerhouse Management & Consulting: \_\_\_\_\_

\_\_\_\_\_  
Owner or Agent for Owner (Print Name)

\_\_\_\_\_  
(Signature)

1007 NW 19<sup>th</sup> Ave Chiefland, FL 32626

**Gary the Carpenter**

800 Simonton  
 Key West, FL 33040  
 CBC1250924

**Estimate**

Date	Estimate #
2/11/2026	3
Customer	Job
Ryon LaChapelle	CONCH FARM

<b>Customer Information</b>
Ryon LaChapelle (305)304-8406 631 Greene Street Email: RyonL@Seatech.cc Key West, FL 33040

Description	Qty	Rate	Amount
631 Greene Stree - Conch Republic Seafood TPO Roof & Gutters. Any requested upgrade of materials by client will be a change order. We will maintain a safe and clean area at all times recognizing that the restaurant will remain open during the work. Any Permit/impact/ or achitectural fees are NOT INCLUDED.			
<hr/>			
TPO Roofing - 11279 SF plus 10% waste + 12,426 SF			
<hr/>			
TPO roofing installation			
Material, per LF	12,426	8.35	103,757.10
Labor per LF	12,426	16.65	206,892.90
<hr/>			
Gutters - 8 in. box type and downspouts			
<hr/>			
Addition of 3 new downspouts at Main Roof			
Subcontract, per LF	54	42.00	2,268.00
Addition of new gutters at main roof (both sides)			
Subcontract, per LF	240	42.00	10,080.00
*Subtotal			322,998.00
<hr/>			
General Conditions			
<hr/>			
Building permit fees, City of KW Building Dept. - Are responsibility of client at time of pick-up - GTC will pickup permit for client at cost plus 20% for administrative fees of permit work.			
<hr/>			
Job supervision and safety monitoring			
Subcontract, perM\$	60	85.00	5,100.00
Material Delivery and Handling			
Subcontract, perM\$	20	85.00	1,700.00
*Subtotal			6,800.00
<hr/>			
<b>Total</b>			<b>329,798.00</b>



**TOMKINS ELECTRIC LLC**  
EC#13008716

## ELECTRICAL PROPOSAL

**Tomkins Electric LLC**  
Cudjoe Key, FL

**Project:** Conch Republic Seafood Company  
**Scope:** Electrical Work

### Price Breakdown

Description	Amount
Labor	\$46,000.00
Materials (conduit, wire, devices, fittings, etc.)	\$10,430.00
<b>Total Contract Sum</b>	<b>\$56,430.00</b>

### Scope of Work

Tomkins Electric LLC shall provide all labor, materials, equipment, and supervision necessary to complete the electrical work for the Conch Republic Seafood Company in accordance with the roof replacement as shown on construction drawings.

Work includes, but is not limited to:

1. Identify and label existing circuits to be de-energized for equipment to be removed to accommodate for new siding
2. Provide and install Lockout/Tagout devices to associated circuit breakers
3. Remove existing conduits/strapping, wire, and boxes associated with lighting
4. Remove existing light fixtures/wire to be re-installed
5. Remove existing conduits/strapping, wire, and boxes associated with video surveillance equipment

6. Remove existing cameras/wire to be re-installed
7. Remove existing conduits/strapping, wire, and boxes associated with audio equipment
8. Remove existing speakers/wire to be re-installed
9. Remove existing conduits/strapping, wire, boxes, and disconnects for roof top equipment if needed to accommodate for new flashing/decking associated with mechanical equipment
10. Provide and install new conduits for lighting, audio/video, and mechanical equipment if existing conduits are deemed not reusable
11. Workers Comp/General Liability Insurance
12. Taxes/Warranty

## **Exclusions**

The following are excluded unless specifically noted:

1. Bonding is not included (payment and performance bonds excluded)
2. Permit fees (to be billed at cost plus 10% administrative fee)
3. Utility company fees and utility service connections
4. Engineering, design changes, or plan revisions
5. Temporary power and temporary lighting (if required, to be quoted separately)
6. Hazardous material handling, removal, or abatement
7. Concrete work, cutting, coring, or restoration beyond specified scope
8. Fire alarm, low voltage, data, security, and communication systems (unless specifically noted)
9. Equipment furnished by others and not specified in this proposal
10. Any work not explicitly described in this proposal
11. Any additional requirements or corrections required by inspectors, plan reviewers, or governing authorities
12. Overtime, night work, or accelerated schedule unless requested

## **Clarifications**

1. All work shall be performed in accordance with NEC and local codes
2. Electrical drawings are diagrammatic; contractor will coordinate field conditions
3. Any additional work required due to unforeseen conditions will be handled via change order

This proposal is valid for 30 days.

**Sincerely,**  
James Tomkins  
Tomkins Electric LLC  
(305) 300-8451  
info@tomkinselectric.com

# Shopping Cart

Product Name		Unit Price	Qty	Subtotal
 <b>Exhaust Fan Grease Box - Includes Down Spout</b>	<a href="#">Edit</a>	\$59.89	<input type="text" value="2"/>	\$119.78

[CONTINUE SHOPPING](#) [CLEAR SHOPPING CART](#) [UPDATE SHOPPING CART](#)

Subtotal	\$119.78
<b>Grand Total</b>	<b>\$119.78</b>
<a href="#">PROCEED TO CHECKOUT</a>	

## Need Help?

### Common Questions

- What should I do if my credit card is declined?
- What if I need to return a product?
- Do you ship to Canada?
- How will I be able to track my order?
- Will I get an order confirmation?

### ESTIMATE SHIPPING AND TAX

Enter your destination to get a shipping estimate.

**Country\***

United States

**State\***

Please select region or state

**Zip\***

# SF7H HURRICANE RATED SUPPLY FAN .75 HP, 1PH, 115V, 2000 CFM, 10" BLOWER

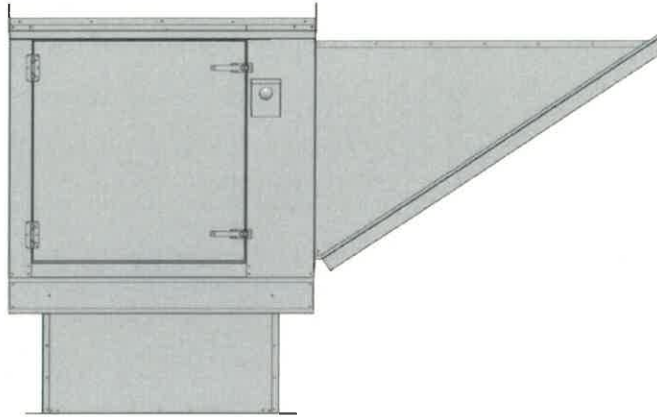

SKU:  
SF7H

Orig. Price \$3,715.21 **Your Price \$3,417.99**  
SHIPPING ESTIMATOR

## **DETAILS**

Belt Drive Hurricane Rated Supply Fan, Made in USA, Miami Dade Certified and tested in accordance to Florida Building Code test protocol TAS-201, Complies with Underwriters Laboratories (UL705) and CSA C22.2, No. 113 Standards. Miami Dade Certified Supply fans are tested for high wind and hurricane resistance applications and tested under Miami-Dade County Notification # ATI 08034. Supply fans are designed to deliver fresh outside supply air when frequent air changes are required. Compact weatherproof design is constructed of G90 galvanized steel. Worried about installation? Building Permits? State or City Codes? No problem. Concerned about working with Inspectors? No Problem. The HoodMart Team can coordinate installation of makeup air hoods with fire suppression systems, saving you valuable time and \$. SERVING restaurant owners, contractors, architects and professional installers nationwide! Downblast fans are designed for general ventilation and should not be used in a commercial kitchen. SF7H HURRICANE RATED SUPPLY FAN .75 HP, 1PH, 115/230V, UL705

BELT DRIVE HURRICANE RATED SUPPLY FAN Single Phase

---

**BELT DRIVE HURRICANE RATED SUPPLY FAN INCLUDES**

- SF7H Belt Drive Hurricane Rated Supply Fan
- Exhaust fan handles 2000 CFM @.250 SP
- .75 HP, 1 Phase, 115/230 V
- Vibration isolation
- Adjustable drive sheaves.
- Designed to supply fresh outside make up air for frequent air changes.
- Includes 21" Sq. Curb
- Recommended for hood sizes 7'-11'

### *BELT DRIVE HURRICANE RATED SUPPLY FAN FEATURES*

- SF7H Hurricane Rated Supply Fan
- Vibration isolation commercial exhaust
- Made in USA
- Compact weatherproof cabinet designed for outdoor mounting
- G90 Galvanized construction
- Horizontal or Down Discharge
- Washable aluminum mesh filters
- Disconnect switch
- High efficiency motors
- Adjustable drive sheaves
- Warranty -2 Year

#### Order Summary

CART SUB- TOTAL	\$3,417.99
ESTIMATED SHIPPING	\$ 300.00
SALES TAX	\$ 256.35
 ORDER TOTAL	 \$3,974.34



Coronado Paint

## **Coronado Rust-A-Void Rust Preventative Polyurethane Enamel (Formerly Rust Scat) – Satin**

(No reviews yet) [Write a Review](#)

**\$79.99/gallon**

**15 each \$1,199.85**

**Sales Tax \$89.99**

**Total \$1,289.84**



Mobile Modular Portable Storage  
 1100 Highway 559  
 Auburndale, FL 33823  
 863-965-3700  
[www.mgrc.com](http://www.mgrc.com)

Lease Quotation and Agreement	
Quote #	Q-606189
Date of Quote	
Quote Expiration Date:	
Lease Term:	2 Months
Estimate Del Date:	06/01/2026
<b>Lessee PO#:</b>	

Lessee Name and Billing Address	Site Information	Lessor Name
Sea Tech of the Florida Keys, Inc. ("Lessee") 631 Green Street Key West, FL 33040 Ryon LaChapelle Phone: (305) 304-8406 ryonl@seatech.cc	Ryon LaChapelle 631 Green Street Key West, FL 33040 Cell: (305) 304-8406 ryonl@seatech.cc	Mobile Modular Portable Storage a Division of McGrath RentCorp ("Lessor") <b>Questions?</b> Contact: Geoff Tatro Direct Phone: (904) 524-2274 geoff.tatro@mobilemodularcontainers.com

Equipment and Accessories	Qty	Monthly Rent	Extended Rent	Taxable
<b>8x40 Storage (Storage Only)</b>	2	\$148.00	\$296.00	Y
Locks	2	\$10.00	\$20.00	Y
Damage Waiver	2	\$20.80	\$41.60	N
<b>Equipment and Accessories Monthly Subtotal:</b>				\$357.60

Charges Upon Delivery	Qty	Charge Each	Total One Time	Taxable
<b>8x40 Storage (Storage Only)</b>				
Delivery	2	\$890.00	\$1,780.00	Y
Return	2	\$890.00	\$1,780.00	Y
<b>Charges Upon Delivery Subtotal:</b>				\$3,560.00

Total Estimated Charges	
Subtotal of Monthly Rent	\$357.60
Personal Property Expense	\$20.80
Taxes on Monthly Charges	\$25.26
<b>Total Charges per Month (including tax)</b>	<b>\$403.66</b>
Charges Upon Delivery (including tax)	\$3,827.00
Estimated Charges Upon Return (including tax)*	\$0.00
<b>Estimated Initial Invoice*</b>	<b>\$4,230.66</b>

**Special Notes**

**Estimated Equipment Value**  
 The Estimated Equipment Value is listed below. Lessee is solely responsible for complying with all insurance requirements set forth in the Lease Terms and Conditions attached hereto.

Equipment Description	Qty	Estimated Equipment Value (each)
8x40 Storage	2	\$11,334.00



# INVOICE

Date	Invoice #
7/29/2025	111650

Bill To
SEATECH OF THE FLORIDA KEYS P.O BOX 420529 SUMMERLAND KEY, FL 33042

Delivered To (Job Site)
1100 SIMONTON KEY WEST, FL 33040

CONTAINER IN	CONTAINER OUT	P.O. No.	Terms	Project
20222		ROBIN		

Description	Ordered	S.O. No.	Unit Price / Rate	Amount
DELIVERY OF 20-YARD DUMPSTER-LOWER KEYS Dumpster Rentals are charged per dumpster (Delivered or Exchanged). It is the customer's responsibility to call our office and request pick-up or exchange services. 305-743-5680  LLAMAR A ROBIN 305-797-1485	1	15-87540	820.00	820.00

Phone #	E-mail	Follow Us Online!	<b>Subtotal</b>	\$820.00
(305) 743-5680	accounting@discountrocksand.com	www.DiscountRockandSand.com	<b>Sales Tax (7.5%)</b>	\$0.00

**Thank You For Your Business!**

We Accept: Visa, Mastercard, Discover, American Express, Business & Personal Checks.

Please mail payment to:  
Discount Rock & Sand, Inc.  
P.O. Box 504484 - Marathon, FL 33050



<b>Total</b>	\$820.00
<b>Payments/Credits</b>	\$0.00
<b>BALANCE DUE</b>	\$820.00