

PROPOSAL

To: The City of Key West  
Address: 525 Angela Street, P.O. Box 1409  
Key West, Florida 33041  
Project Title: **College Road Enhancements  
Overseas Highway to Kokenzie Road**  
Project No.: GN- 0711

Bidder's person to contact for additional information on this Proposal:

Name:                     Dan Higgins                      
Telephone:                     (734)996-9500                    

BIDDER'S DECLARATION AND UNDERSTANDING

The undersigned, hereinafter called the Bidder, declares that the only persons or parties interested in this Proposal are those named herein, that this Proposal is, in all respects, fair and without fraud, that it is made without collusion with any official of the Owner, and that the Proposal is made without any connection or collusion with any person submitting another Proposal on this Contract.

The Bidder further declares that he has carefully examined the Contract Documents, that he has personally inspected the Project, that he has satisfied himself as to the quantities involved, including materials and equipment, and conditions of work involved, including the fact that the description of the quantities of work and materials, as included herein, is brief and is intended only to indicate the general nature of the work and to identify the said quantities with the detailed requirements of the Contract Documents, and that this Proposal is made according to the provisions and under the terms of the Contract Documents, which Documents are hereby made a part of this Proposal.

The Bidder further agrees that he has exercised his own judgment regarding the interpretation of subsurface information and has utilized all data which he believes pertinent from the Engineer, Owner, and other sources in arriving at his conclusions.

The Bidder further agrees, as evidenced by signing the Proposal, which if awarded a Contract, the Florida Trench Safety Act and applicable trench safety standards will be complied with.

The Bidder understands and agrees that if a Contract is awarded, the Owner may elect to award all schedules under one Contract, separately, or in any combination that best serves the interests of the Owner.

CONTRACT EXECUTION AND BONDS

The Bidder agrees that if this Proposal is accepted, he will, within 10 days, not including Sundays and legal holidays, after Notice of Award, sign the Contract in the form annexed hereto, and will at that time, deliver to the Owner examples of the Performance Bond and Payment Bond required herein, and evidence of holding required licenses and certificates, and will, to the extent of his Proposal, furnish all machinery, tools, apparatus, and other means of construction and do the work and furnish all the materials necessary to complete all work as specified or indicated in the Contract Documents.

CERTIFICATES OF INSURANCE

Bidder agrees to furnish the Owner, before commencing the work under this Contract, the certificates of insurance as specified in these Documents.

START OF CONSTRUCTION AND CONTRACT COMPLETION TIME

*The Bidder further agrees to begin work within 14 calendar days of the Notice to Proceed (NTP) and to complete the construction in all respects within 120 calendar days from the date of the NTP.*

LIQUIDATED DAMAGES

In the event the Bidder is awarded the Contract and fails to complete the work within the time limit or extended time limit agreed upon, as more particularly set forth in the Contract Documents, liquidated damages shall be paid to the Owner based on the current FDOT Standard Specifications Section 8-10 until the work has been satisfactorily completed as provided by the Contract Documents. Sundays and legal holidays shall be included in determining days in default. FDOT 8-10 Code requirements govern, and herewith made a part of the Contract.

| Original Contract Amount               | Daily Charge Per Calendar Day |
|--|-------------------------------|
| \$50,000 and Under                     | \$313                         |
| Over \$50,000 but less then \$250,000  | \$580                         |
| \$250,000 but less than \$500,000      | \$715                         |
| \$500,000 but less than \$2,500,000    | \$1,423                       |
| \$2,500,000 but less than \$5,000,000  | \$2,121                       |
| \$5,000,000 but less than \$10,000,000 | \$3,057                       |

ADDENDA

The Bidder hereby acknowledges that he has received Addenda No's. 1, \_\_\_\_\_, \_\_\_\_\_, \_\_\_\_\_, \_\_\_\_\_, (Bidder shall insert No. of each Addendum received) and agrees that all addenda issued are hereby made part of the Contract Documents, and the Bidder further agrees that his Proposal(s) includes all impacts resulting from said addenda.

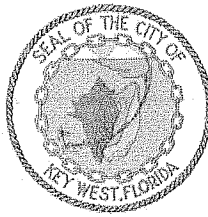

## THE CITY OF KEY WEST

Post Office Box 1409 Key West, FL 33041-1409 (305) 809-3867

### ADDENDUM # 1 COLLEGE ROAD ENHANCEMENTS – GN 0711

March 29, 2011

To All Bidders,

The following changes are hereby made a part of Project number GN 0711, College Road Enhancements, as fully as completely as if the same were fully set forth therein:

The bid opening date has been extended to WEDNESDAY APRIL 13, 2011 at 3:30 p.m.

#### Question/Response:

1. **Question:** Will detectable warnings also be included in the area where the 4-foot wide section leading from the bus pad meets the edge of the street?

**Response:** Yes, it will. Detectable warnings will have an area of 2-ft. deep x 4-ft. wide and will be placed approximately 6 to 8-inches back from the edge of pavement.

2. **Question:** Bridging over structure. Will any wire mesh or equivalent reinforcement be required?

**Response:** Yes, there will. Longitudinally, #6 bars should be spaced every 6". They should extend 1-foot into the thickened portion before the bridged section. Transversely, #6 bars should be spaced every 12". Please refer to attached sketch below.

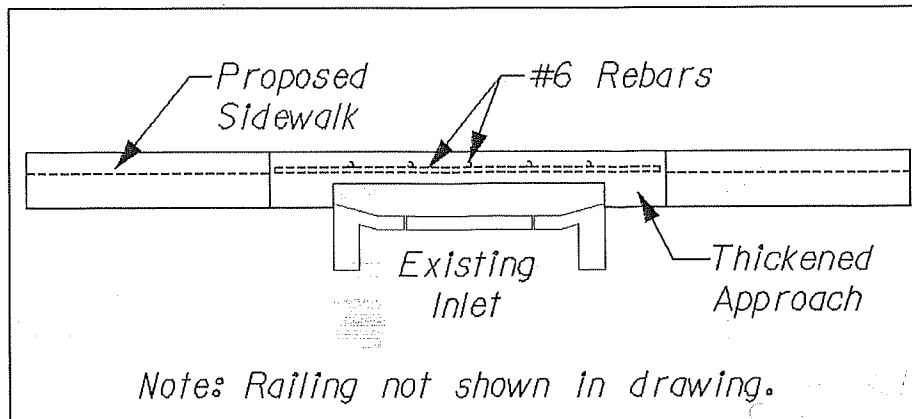

3. **Question:** Will a curb be required on the inside for wheelchair occupants?

**Response:** No. Please refer to the General Notes, item #1.

**General Notes:**

1. Sheet C-12: Construction Details show the use of an aluminum pipe guiderail. This will be changed to an aluminum pedestrian/bicycle picket railing as per 2010 FDOT Design Standards 860, Sheet no. 2 of 5. Height shall be 3'-6" (42"). Please refer to drawing below and the .

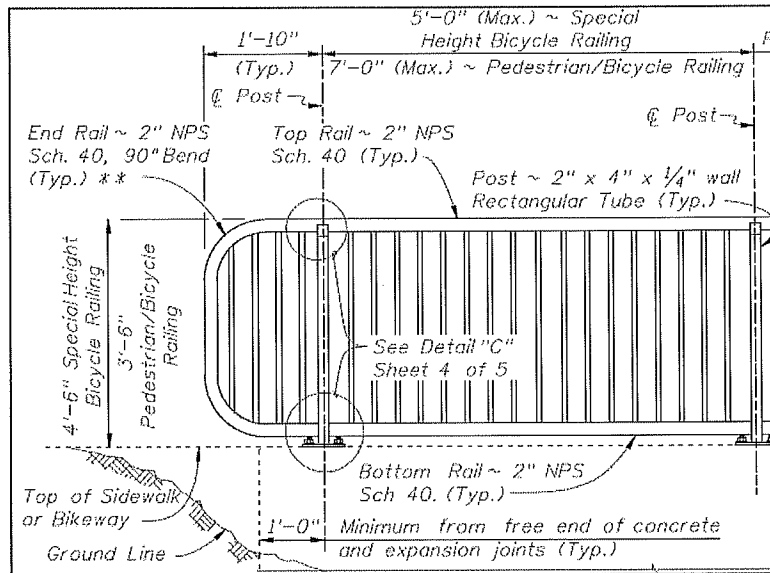

2. An additional Add/Alternate item will be gravel (1/2" to 3/4") with a quantity of 65 Tons. Please refer to following sheet which will replace page 21 of the Bid Documents package. In addition, please refer to sheets C-07 and C-08 at end of addendum denoting where swales will be incorporated.

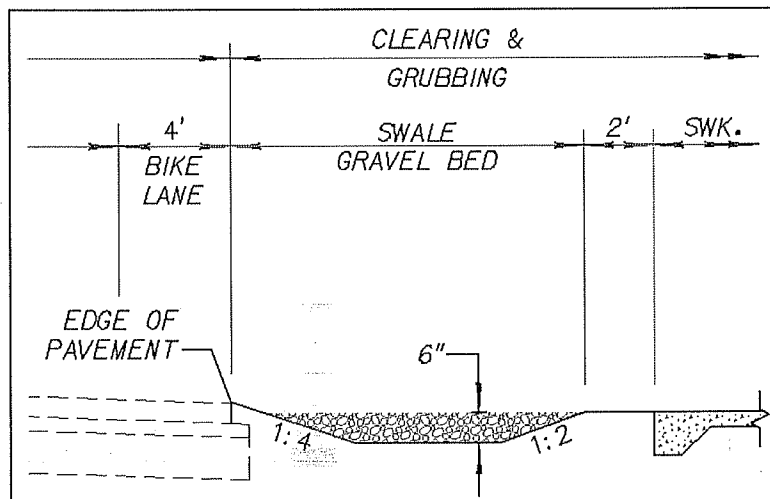

*Key to the Caribbean – average yearly temperature 77 ° Fahrenheit.*

3. Please note that the number of shelters has been reduced from six (6) to two (2). These shelters are located at Sta. 18+71.60 and Sta. 24+95.80.
4. Please note that the 26.65-ft. long 5-ft. wide path leading to the bus stop at station 10+65.10 on sheet C-05 is no longer required. This item may be removed from the total quantity of concrete required.

**ADD/ALTS 1-4**

**Add Alternates are not a part of the base bid and shall only be added to the contract at the owners discretion.**

| <u>Item</u>   | <u>Quant.</u> | <u>Unit</u> | <u>UP (Fig)</u> | <u>UP (Words)</u> | <u>Extended Total Amount</u> |
|---|---------------|-------------|-----------------|-------------------|------------------------------|
| 1). Seepage Trench  |               |             |                 |                   |                              |
|   | 100           | LF          | \$ _____        | _____             | \$ _____                     |
| 2). Striping (White retro-reflective 6", as required)   |               |             |                 |                   |                              |
|   | 0.6           | NM          | \$ _____        | _____             | \$ _____                     |
| 3). Bus Shelters  |               |             |                 |                   |                              |
|   | 2             | EA          | \$ _____        | _____             | \$ _____                     |
| 4). Gravel Stone, 1/2 inch to 3/4 inch diameter (includes cost of material and labor to excavate 6" deep shoulder, grade bottom of shoulder, and backfill. Gravel will be for use in specified areas between edge of pavement and front of sidewalk as directed by the engineer). |               |             |                 |                   |                              |
|   | 65            | TONS        | \$ _____        | _____             | \$ _____                     |

**TOTAL OF ADD/ALT UNIT PRICE ITEMS LISTED ABOVE**

TOTAL OF ADD/ALT UNIT PRICE ITEMS LISTED ABOVE

\$ \_\_\_\_\_ Dollars and \_\_\_\_\_ Cents  
 (Amount Written in Words has Precedence)

*Key to the Caribbean – average yearly temperature 77 ° Fahrenheit.*

| Tree/ Shrub Station | Botanical Name                   | Common Name            | Remove/ Relocate |
|---------------------|----------------------------------|------------------------|------------------|
| ③ 21+51             | Quercus Virginiana               | Live Oak (White/Trunk) | Remove           |
| ② 23+53             | Conocarpus erectus               | Croton Buttonwood      | Remove           |
| ③ 23+70             | Conocarpus erectus               | Green Buttonwood       | Remove           |
| ③ 23+81             | Conocarpus erectus var. sericeus | Silver Buttonwood      | Remove           |

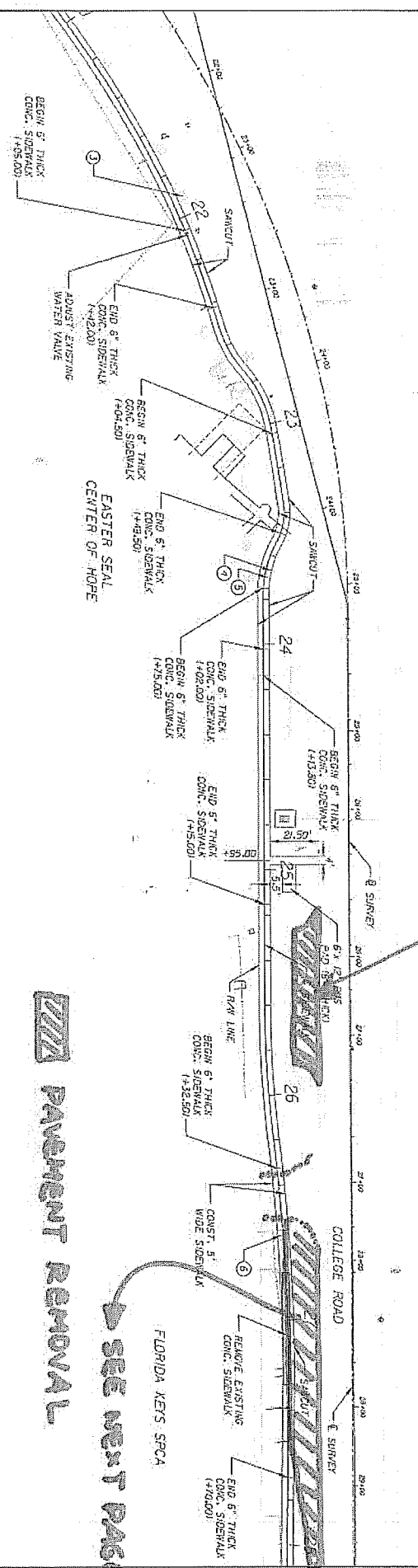

660 SF x 0.5 FC = 330 CF = 18.2 CY  
 USE [16 CY]  
 15 CY x 1.3 TONS = 19.5 TONS  
 19.5 TONS

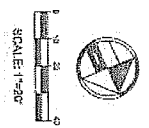

|             |           |      |                      |      |
|-------------|-----------|------|----------------------|------|
| DESCRIPTION | REVISIONS | DATE | APPROVED BY:         | DATE |
| 1           |           |      | FRANZ L. TRACY, P.E. |      |
| 2           |           |      | STATE OF FLORIDA     |      |
| 3           |           |      |                      |      |
| 4           |           |      |                      |      |
| 5           |           |      |                      |      |



**BERNIELLO AMMILL & PARTNERS, INC.**  
 ARCHITECTURE, ENGINEERING, PLANNING  
 LANDSCAPE ARCHITECTURE - INTERIOR DESIGN  
 2801 S. WASHINGTON DRIVE, 5th FLOOR  
 MIAMI, FL 33133  
 (305) 852-2000 FAX: (305) 660-9770

CDMA NO.: 13018220  
 SCALE: 1" = 20'  
 DATE: 07/02/10  
 DRAWN: JH  
 CHECKED: JLV/J.E.L.  
 CAD FILE: [ ]

**COLLEGE ROAD ENHANCEMENTS**

SHEET NO. C-07

PLAN SHEET 3 OF 5

| REVISIONS |             | APPROVED BY: |  | <br>BERTELLO AAMILL & PARTNERS, INC.<br>ARCHITECTURE - ENGINEERING - PLANNING<br>LANDSCAPE ARCHITECTURE - INTERIOR DESIGN<br>MIAMI FL, 33130<br>(305) 456-2852 FAX (305) 460-2776 | COPLAN NO.: 10218-002<br>SCALE: 1" = 30'<br>DATE: 07/02/10<br>DRAWN: JLN<br>CHECKED: JBY/EJT<br>CADD FILE: | <br>HOLD # OR 0711 | <br>FTH# 421284 | COLLEGE ROAD<br>ENHANCEMENTS | SHEET NO.<br>C-08 |
|-----------|-------------|--------------|--|--|--|---|--|------------------------------|-------------------|
| 1         | DESCRIPTION | DATE         | FRANZ L. TRISY, PE<br>STATE OF FLORIDA |  |  |   |  |                              |                   |
| 2         |             |              |  |  |  |   |  |                              |                   |
| 3         |             |              |  |  |  |   |  |                              |                   |
| 4         |             |              |  |  |  |   |  |                              |                   |
| 5         |             |              |  |  |  |   |  |                              |                   |

PLAN SHEET 4 OF 5

 PAVEMENT REMOVAL

KEY WEST GOLF CLUB

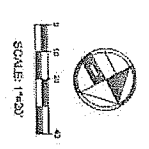
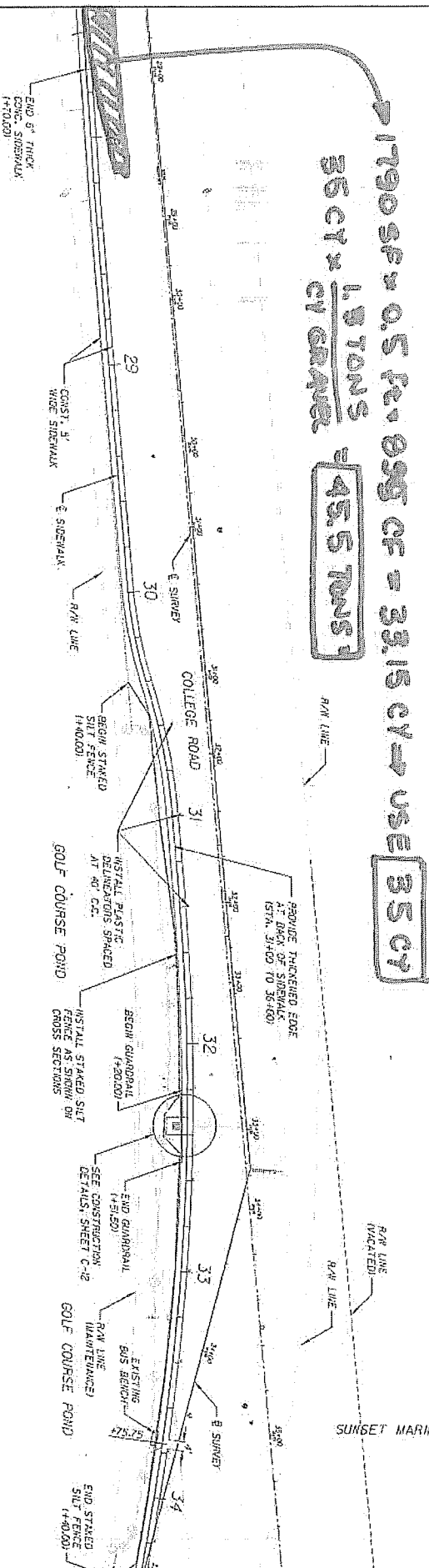

All Bidders shall acknowledge receipt and acceptance of this Addendum NO. 1 by acknowledging Addendum in their proposal or by submitting the addendum with the bid package. Bids submitted without acknowledgement or without this Addendum may be considered non-responsive.



**Signature**



**Name of Business**



## SALES AND USE TAXES

The Bidder agrees that all federal, state, and local sales and use taxes are included in the stated bid prices for the work.

## UNIT PRICE ITEMS

The Bidder further proposes to accept as full payment for the work proposed herein the amounts computed under the provisions of the Contract Documents and based on the following unit price amounts, it being expressly understood that the unit prices are independent of the exact quantities involved. The Bidder agrees that the unit prices represent a true measure of the labor and materials required to perform the work, including all allowances for overhead and profit for each type and unit of work called for in these Contract Documents. The amounts shall be shown in both words and figures. In case of a discrepancy, the amount shown in words shall govern. Unit price line items may be deleted, reduced or increased as needed within the awarded contract price by the city.

## COLLEGE ROAD ENHANCEMENTS

### BID SCHEDULE

The Bidder further Proposes to accept as full payment for the work Proposed herein the amounts computed under the Provisions of the Contract Documents and based on the following unit Price amounts, it being expressly understood that the unit Prices are independent of the exact quantities involved. The Bidder agrees that the unit Prices represent a true measure of the labor and materials required to perform the work, including all allowances for overhead and Profit for each type and unit of work called for in these Contract Documents. The amounts shall be shown in both words and figures. In case of a discrepancy, the amount shown in words shall govern. . Unit price line items may be deleted, reduced or increased as needed within the awarded contract price by the city

| <u>Item</u> | <u>Quant.</u> | <u>Unit</u> | <u>UP (Fig)</u> | <u>UP (Words)</u> | <u>Extended Total Amount</u> |
|-------------|---------------|-------------|-----------------|-------------------|------------------------------|
|-------------|---------------|-------------|-----------------|-------------------|------------------------------|

1. Performance and Payment Bonds

|  |   |    |                    |                                     |                    |
|--|---|----|--------------------|-------------------------------------|--------------------|
|  | 1 | LS | \$ <u>3,700.00</u> | <u>Thirty Seven Hundred Dollars</u> | \$ <u>3,700.00</u> |
|--|---|----|--------------------|-------------------------------------|--------------------|

2.) Mobilization / Demobilization, FDOT Grant Requirements, General & Supplementary Conditions, MOT, Certified AutoCAD As-Builts)

a.) Mobilization / Field Engineering /Testing / Environmental / Construction layout/ pre –construction video (paid 25%, then on percentage of completion)

|  |   |    |                     |   |                     |
|--|---|----|---------------------|---|---------------------|
|  | 1 | LS | \$ <u>15,200.00</u> | <u>Fifteen Thousand Two Hundred Dollars</u> | \$ <u>15,200.00</u> |
|--|---|----|---------------------|---|---------------------|

b.) Demobilization (paid at completion of final punch list completion)

|  |   |    |                    |                                   |                    |
|--|---|----|--------------------|-----------------------------------|--------------------|
|  | 1 | LS | \$ <u>5,400.00</u> | <u>Fifty Four Hundred Dollars</u> | \$ <u>5,400.00</u> |
|--|---|----|--------------------|-----------------------------------|--------------------|

c.) FDOT Grant Requirements, General & Supplementary Conditions, (paid 25%, then on percentage of completion)

|  |   |    |                     |   |                     |
|--|---|----|---------------------|---|---------------------|
|  | 1 | LS | \$ <u>17,544.00</u> | <u>Seventeen Thousand Five Hundred Forty Four Dollars</u> | \$ <u>17,544.00</u> |
|--|---|----|---------------------|---|---------------------|

d.) MOT, (paid 25%, then on percentage of completion)

|  |   |    |                     |                                    |                     |
|--|---|----|---------------------|------------------------------------|---------------------|
|  | 1 | LS | \$ <u>22,000.00</u> | <u>Twenty Two Thousand Dollars</u> | \$ <u>22,000.00</u> |
|--|---|----|---------------------|------------------------------------|---------------------|

e.) Certified AutoCAD As-Builts / Surveyor (paid after submission and acceptance of as-builts)

|  |   |    |                    |                                   |                    |
|--|---|----|--------------------|-----------------------------------|--------------------|
|  | 1 | LS | \$ <u>4,400.00</u> | <u>Forty Four Hundred Dollars</u> | \$ <u>4,400.00</u> |
|--|---|----|--------------------|-----------------------------------|--------------------|

| <u>Item</u> | <u>Quant.</u> | <u>Unit</u> | <u>UP (Fig)</u> | <u>UP (Words)</u> | <u>Extended Total Amount</u> |
|-------------|---------------|-------------|-----------------|-------------------|------------------------------|
|-------------|---------------|-------------|-----------------|-------------------|------------------------------|

3). Clearing and Grubbing\_ (to be paid for as described in the current FDOT Standards and Specifications, Section 110; includes cutting back grass growing over edge of pavement; includes tree/plant relocation or transplantation; includes pruning tree roots adjacent to roadway as required)

|  |      |    |                     |                                    |                     |
|--|------|----|---------------------|------------------------------------|---------------------|
|  | 0.98 | AC | \$ <u>22,000.00</u> | <u>Twenty Two Thousand Dollars</u> | \$ <u>21,560.00</u> |
|--|------|----|---------------------|------------------------------------|---------------------|

4). Sidewalk Installation (material and labor to install; including excavation, backfill and compaction)

a. 4" Depth (e.g. sidewalk throughout most of project)

|  |     |    |                 |                             |                     |
|--|-----|----|-----------------|-----------------------------|---------------------|
|  | 974 | SY | \$ <u>88.00</u> | <u>Eighty Eight Dollars</u> | \$ <u>85,712.00</u> |
|--|-----|----|-----------------|-----------------------------|---------------------|

b. 6" Depth (e.g. sidewalk crossing driveways, 6' X 12' bus stop pads)

|  |     |    |                  |                                 |                     |
|--|-----|----|------------------|---------------------------------|---------------------|
|  | 199 | SY | \$ <u>104.00</u> | <u>One Hundred Four Dollars</u> | \$ <u>20,696.00</u> |
|--|-----|----|------------------|---------------------------------|---------------------|

c. Thickened Edge (sections of sidewalk / driveway without f curbs and as directed)

|  |       |    |                 |                        |                     |
|--|-------|----|-----------------|------------------------|---------------------|
|  | 3,362 | LF | \$ <u>16.00</u> | <u>Sixteen Dollars</u> | \$ <u>53,792.00</u> |
|--|-------|----|-----------------|------------------------|---------------------|

d. Bridged sidewalk over ditch bottom inlet (material and labor to install; including formwork required for 6" thick concrete)

|  |   |    |                  |                                |                    |
|--|---|----|------------------|--------------------------------|--------------------|
|  | 5 | CY | \$ <u>610.00</u> | <u>Six Hundred Ten Dollars</u> | \$ <u>3,050.00</u> |
|--|---|----|------------------|--------------------------------|--------------------|

5). Curb Installation (material and labor to install; including excavation, backfill and compaction)

a. FDOT Type "F"

|  |    |    |                 |                          |                    |
|--|----|----|-----------------|--------------------------|--------------------|
|  | 50 | LF | \$ <u>46.00</u> | <u>Forty Six Dollars</u> | \$ <u>2,300.00</u> |
|--|----|----|-----------------|--------------------------|--------------------|

b. Flared end curb

|  |   |    |                  |  |                  |
|--|---|----|------------------|--|------------------|
|  | 1 | EA | \$ <u>125.00</u> | <u>One Hundred Twenty Five Dollars</u> | \$ <u>125.00</u> |
|--|---|----|------------------|--|------------------|

6). Guardrail (e.g. for section of sidewalk bridged over ditch bottom inlet)

|  |    |    |                  |                                       |                    |
|--|----|----|------------------|---------------------------------------|--------------------|
|  | 35 | LF | \$ <u>165.00</u> | <u>One Hundred Sixty Five Dollars</u> | \$ <u>5,775.00</u> |
|--|----|----|------------------|---------------------------------------|--------------------|

7). Asphalt/sp 9.5/1.5" (e.g. for incidental damage to sections of asphalt where sidewalk is formed close to edge of pavement and where 6" sidewalk crosses driveways)

|  |    |    |                  |                                  |                    |
|--|----|----|------------------|----------------------------------|--------------------|
|  | 50 | SY | \$ <u>120.00</u> | <u>One Hundred Twenty Dollar</u> | \$ <u>6,000.00</u> |
|--|----|----|------------------|----------------------------------|--------------------|

8). Utility Adjustments (cost for complete installation, labor and materials)

a. Adjust water valves / boxes (FKAA) vertically and/or laterally as required (complete cost for material and labor to adjust existing utility features as required)

|  |   |    |                  |  |                  |
|--|---|----|------------------|--|------------------|
|  | 3 | EA | \$ <u>185.00</u> | <u>One Hundred Eighty Five Dollars</u> | \$ <u>558.00</u> |
|--|---|----|------------------|--|------------------|

| <u>Item</u> | <u>Quant.</u> | <u>Unit</u> | <u>UP (Fig)</u> | <u>UP (Words)</u> | <u>Extended Total Amount</u> |
|-------------|---------------|-------------|-----------------|-------------------|------------------------------|
|-------------|---------------|-------------|-----------------|-------------------|------------------------------|

9). Silt Fence (e.g. for use behind back of proposed sidewalk at wetland area, as shown on plans)

|  |     |    |                |                      |                    |
|--|-----|----|----------------|----------------------|--------------------|
|  | 415 | LF | \$ <u>3.00</u> | <u>Three Dollars</u> | \$ <u>1,245.00</u> |
|--|-----|----|----------------|----------------------|--------------------|

10). Plastic Delineators – flexible tubing (cost for complete installation, labor, and materials)

|  |    |    |                 |                            |                    |
|--|----|----|-----------------|----------------------------|--------------------|
|  | 20 | EA | \$ <u>67.00</u> | <u>Sixty Seven Dollars</u> | \$ <u>1,340.00</u> |
|--|----|----|-----------------|----------------------------|--------------------|

11). ADAAG Detectable Warning System (2-1/4 x 4 x 8 Endicott Red Brick Pavers (cost for complete installation, labor, and materials)

|  |    |    |                  |   |                    |
|--|----|----|------------------|---|--------------------|
|  | 12 | SP | \$ <u>128.00</u> | <u>one Hundred Twenty Eight Dollars</u> | \$ <u>1,536.00</u> |
|--|----|----|------------------|---|--------------------|

12). Sodding (areas disturbed by construction activity -- replace with same material)

|  |      |    |                |                                       |                     |
|--|------|----|----------------|---------------------------------------|---------------------|
|  | 3200 | SY | \$ <u>4.75</u> | <u>Four Dollars Seventy Five Cent</u> | \$ <u>15,200.00</u> |
|--|------|----|----------------|---------------------------------------|---------------------|

13). Remove Existing Trees/Shrubs (0-10" Diameter). Includes all Labor, Materials, Equipment and Maintenance, and Disposal / including city permit requirements

|  |   |    |                  |                                   |                  |
|--|---|----|------------------|-----------------------------------|------------------|
|  | 4 | EA | \$ <u>130.00</u> | <u>one Hundred Thirty Dollars</u> | \$ <u>520.00</u> |
|--|---|----|------------------|-----------------------------------|------------------|

14). Remove Existing Tree (over 10" Diameter) Includes all Labor, Materials, Equipment and Maintenance, and Disposal / including city permit requirements

|  |   |    |                  |                                  |                  |
|--|---|----|------------------|----------------------------------|------------------|
|  | 2 | EA | \$ <u>150.00</u> | <u>one Hundred Fifty Dollars</u> | \$ <u>300.00</u> |
|--|---|----|------------------|----------------------------------|------------------|

15). Business Sign relocation (Includes all Labor, Materials, and Equipment to remove and replace existing signs as directed by engineer)

|  |   |    |                  |                                    |                    |
|--|---|----|------------------|------------------------------------|--------------------|
|  | 3 | EA | \$ <u>350.00</u> | <u>Three Hundred Fifty Dollars</u> | \$ <u>1,050.00</u> |
|--|---|----|------------------|------------------------------------|--------------------|

16). Allowance

|  |  |    |                  |                        |                  |
|--|--|----|------------------|------------------------|------------------|
|  |  | LS | \$ <u>30,000</u> | <u>Thirty thousand</u> | \$ <u>30,000</u> |
|--|--|----|------------------|------------------------|------------------|

**TOTAL OF ALL EXTENDED UNIT PRICE ITEMS LISTED ABOVE including allowance items**  
**\$ 319,000.00**

\$ Three Hundred Nineteen Thousand Dollars and 00 Cents

(Amount Written in Words has Precedence)

ADD/ALTS 1-4

Add Alternates are not a part of the base bid and shall only be added to the contract at the owners discretion.

| Item | Quant. | Unit | UP (Fig) | UP (Words) | Extended Total Amount |
|------|--------|------|----------|------------|-----------------------|
|------|--------|------|----------|------------|-----------------------|

1). Seepage Trench

|  |     |    |                 |  |                    |
|--|-----|----|-----------------|--|--------------------|
|  | 100 | LF | \$ <u>73.25</u> | <u>Seventy Three Dollars Twenty Five Cents</u> | \$ <u>7,325.00</u> |
|--|-----|----|-----------------|--|--------------------|

2). Striping (White retro-reflective 6", as required)

|  |     |    |                    |  |                    |
|--|-----|----|--------------------|--|--------------------|
|  | 0.6 | NM | \$ <u>5,325.00</u> | <u>Fifty Three Hundred Twenty Five Dollars</u> | \$ <u>3,195.00</u> |
|--|-----|----|--------------------|--|--------------------|

3). Bus Shelters

|  |   |    |                    |                                     |                     |
|--|---|----|--------------------|-------------------------------------|---------------------|
|  | 2 | EA | \$ <u>7,400.00</u> | <u>Seventy Four Hundred Dollars</u> | \$ <u>14,800.00</u> |
|--|---|----|--------------------|-------------------------------------|---------------------|

4). Gravel Stone, 1/2 inch to 3/4 inch diameter (includes cost of material and labor to excavate 6" deep shoulder, grade bottom of shoulder, and backfill. Gravel will be for use in specified areas between edge of pavement and front of sidewalk as directed by the engineer).

|  |    |      |                 |                           |                    |
|--|----|------|-----------------|---------------------------|--------------------|
|  | 65 | TONS | \$ <u>86.00</u> | <u>Eighty Six Dollars</u> | \$ <u>5,590.00</u> |
|--|----|------|-----------------|---------------------------|--------------------|

TOTAL OF ADD/ALT UNIT PRICE ITEMS LISTED ABOVE

\$ 30,910.00

\$ Thirty Thousand Nine Hundred Ten Dollars and 00 Cents

(Amount Written in Words has Precedence)

List items to be performed by Contractor's own forces and the estimated total cost of these items.  
(Use additional sheets if necessary.)

Earth Work

MOT

Administrative

Signs

Railings

Soil

SUBCONTRACTORS

The Bidder further proposes that the following subcontracting firms or businesses will be awarded subcontracts for the following portions of the work in the event that the Bidder is awarded the Contract:  
Note to Bidder: Subcontractors shall be prequalified to perform projects for FDOT.

Concrete  
Portion of Work

Bella  
Name

111 US Hwy 1 #110 , Keywest , FL , 33040  
Street City State Zip

Survey  
Portion of Work

Charles Tollen & Associates, Inc  
Name

2887 Tamiami Trail , Naples , FL , 34112  
Street City State Zip

\_\_\_\_\_  
Portion of Work

\_\_\_\_\_  
Name

\_\_\_\_\_  
Street City State Zip

\_\_\_\_\_  
Portion of Work

\_\_\_\_\_  
Name

\_\_\_\_\_  
Street City State Zip

SURETY

Hartford Accident & Indemnity Co. whose address is  
P.O. BOX 3001, Troy, MI, 48007  
Street City State Zip

BIDDER

The name of the Bidder submitting this Proposal is

Douglas N. Higgins, Inc. doing business at  
3390 Travis Pointe Rd. Suite A, Ann Arbor, MI, 48108  
Street City State Zip

which is the address to which all communications concerned with this Proposal and with the Contract shall be sent.

The names of the principal officers of the corporation submitting this Proposal, or of the partnership, or of all persons interested in this Proposal as principals are as follows:

| Name  | Title                        |
|---|------------------------------|
| <u>Douglas N. Higgins</u>   | <u>President</u>             |
| <u>R. Suzanne Hawker</u>  | <u>Secretary / Treasurer</u> |
| <u>William D. Higgins,</u><br><u>James H. Sweet &amp;</u><br><u>Kelly A. Wilkie</u> | <u>Vice-President</u>        |
| _____   | _____                        |
| _____   | _____                        |



If Sole Proprietor or Partnership

IN WITNESS hereto the undersigned has set his (its) hand this \_\_\_\_\_ day of \_\_\_\_\_ 2011.

\_\_\_\_\_  
Signature of Bidder

\_\_\_\_\_  
Title

If Corporation

IN WITNESS WHEREOF the undersigned corporation has caused this instrument to be executed and its seal affixed by its duly authorized officers this 30th day of March 2011.

(SEAL)

Douglas N. Higgins, Inc.  
Name of Corporation

By Kelly A. Wilkie

Title Vice-President

Attest R. Suzanne Hawker  
Secretary

CERTIFICATE OF SECRETARY

The undersigned, being the duly elected secretary of Douglas N. Higgins, Inc., a Michigan corporation, hereby certifies that the following resolution was duly adopted by the Board of Directors of said corporation at a meeting held on May 15, 2010 and that said resolution is in full force and effect:

"RESOLVED, That the following listed persons are hereby authorized to execute, on behalf of Douglas N. Higgins, Inc., any and all contracts and documents."

Douglas N. Higgins

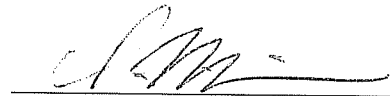

William D. Higgins



James H. Sweet



Kelly A. Wilkie

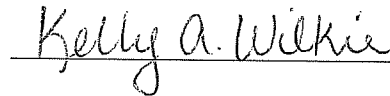

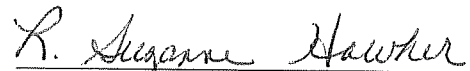
  
R. Suzanne Hawker  
R. Suzanne Hawker  
Secretary

Dated: May 15, 2010



DOUGLAS N. HIGGINS, INC.  
EXPERIENCE - PAST EIGHT YEARS - GROUP 1

|   |  |
|---|--|
| <p><b>Project Name:</b> City County Flow Swap</p> <p><b>Owner - Address - Project Manager - Phone:</b><br/>Collier County Public Utilities Engineering<br/>3301 East Tamiami Trail, Building H<br/>Naples, Florida 34112<br/>Sandy Sridhar</p> <p><b>Engineer - Address - Phone:</b><br/>Agnoli, Barber and Brundage<br/>7400 Trail Blvd.<br/>Naples, Florida 34102<br/>Dominic Amico</p> <p><b>Contract Date:</b><br/><b>Final Contract Amount:</b><br/><b>Completion Date:</b><br/><b>Project Description:</b><br/>Installation of force main, MOV's and valve vaults to two locations which would allow bypass from Collier County to the City of Naples.</p>  | <p><b>Project Name:</b> Collier County Justice Center</p> <p><b>Owner - Address - Project Manager - Phone:</b><br/>Collier County Facilities Management Department<br/>3301 East Tamiami Trail<br/>Naples, Florida 34112<br/>John Clements</p> <p><b>Engineer - Address - Phone:</b><br/>Q. Grady Minor and Associates, P.A.<br/>3800 Via Del Rey<br/>Bonita Springs, Florida 34134<br/>David Schmitt<br/>239-947-1144</p> <p><b>Contract Date:</b> \$81,950.00<br/><b>Final Contract Amount:</b> \$141,568.41<br/><b>Completion Date:</b> August, 2009<br/><b>Project Description:</b><br/>Construction of grinder pump station (vault), installation of muffin monster (grinder/auger assembly), new sanitary sewer and manholes. Replacement of the existing sanitary sewer with a new 12-inch main and a high water alarm system.</p>          |
| <p><b>Project Name:</b> Pump Station S-6 Gearbox Replacement</p> <p><b>Owner - Address - Project Manager - Phone:</b><br/>South Florida Water Management District<br/>2101 Centrepark West Drive, Suite 110<br/>West Palm Beach, Florida 33409<br/>Gerard Flynn</p> <p><b>Engineer - Address - Phone:</b><br/>South Florida Water Management District<br/>3301 Gun Club Road<br/>West Palm Beach, Florida 33406<br/>Michael Millares</p> <p><b>Contract Date:</b> December 3, 2009<br/><b>Final Contract Amount:</b> \$2,191,945.00<br/><b>Completion Date:</b> May 2010<br/><b>Project Description:</b><br/>Replacement of three massive gearboxes for three 84" Gas Engine driven Vertical Turbine Pumps.</p> | <p><b>Project Name:</b> Cove Stormwater Pump Station Imp.</p> <p><b>Owner - Address - Project Manager - Phone:</b><br/>City of Naples<br/>Department of Streets and Stormwater<br/>295 Riverside Circle<br/>Naples, Florida 34102<br/>(239) 213-5000</p> <p><b>Engineer - Address - Phone:</b><br/>AECOM<br/>4415 Metro Parkway<br/>Suite 404<br/>Fort Myers, Florida 33916<br/>(239) 278-7996</p> <p><b>Contract Date:</b> 2/4/09 Award, 3/16/09 NTP<br/><b>Final Contract Amount:</b> \$2,778,000.00<br/><b>Completion Date:</b> 2/8/10 (Contract)<br/><b>Project Description:</b><br/>Replacement of large Vertical Turbine Pumps. Installation of a large, below grade and water table, cast in place structure which included gates, an 60" bypass pipe, a trash rake. Project also included significant Electrical &amp; Instrumentation</p> |
| <p><b>Project Name:</b> Master Pump Station 305 Rehabilitation</p> <p><b>Owner - Address - Project Manager</b><br/>Collier County<br/>Public Utilities Engineering Department<br/>3301 Tamiami Trail East, Building H<br/>Naples, Florida 34112<br/>Sandy Sridhar</p> <p><b>Engineer - Address:</b><br/>Q. Grady Minor and Associates, P.A.<br/>3800 Via Del Rey<br/>Bonita Springs, Florida 34134<br/>David Schmitt</p> <p><b>Contract Date:</b> August 11, 2008<br/><b>Final Contract Amount:</b> \$444,000.00<br/><b>Completion Date:</b> January 16, 2009<br/><b>Project Description:</b><br/>Fully rehab 2300 GPM Master Pump Station</p>  | <p><b>Project Name:</b> Water Reuse Piping Modifications / Reuse System Upgrade</p> <p><b>Owner - Address - Project Manager - Phone:</b><br/>City of Marco Island<br/>Public Utilities<br/>50 Bald Eagle Drive<br/>Marco Island, Florida 34145<br/>Bruce Weinstein<br/>239-389-5000</p> <p><b>Engineer:</b><br/>Metcalf and Eddy</p> <p><b>Contract Date:</b> February 10, 2008<br/><b>Final Contract Amount:</b> \$849,171.67<br/><b>Completion Date:</b> November 2008<br/><b>Project Description:</b><br/>Rehab 500,000 Gallon Tank and convert potable water facility to reuse storage facility</p>  |

DOUGLAS N. HIGGINS, INC.  
EXPERIENCE - PAST EIGHT YEARS - GROUP 1

|  |   |
|--|---|
| <p><b>Project Name:</b> CAT Operations &amp; Administration Center Pump Station and Force Main Connection</p> <p><b>Owner - Address - Project Manager:</b><br/>Collier County<br/>Alternative Transportation Division<br/>2885 South Horseshoe Drive<br/>Naples, Florida 34104<br/>Sue Faulkner</p> <p><b>Engineer:</b><br/>Q. Grady Minor<br/>3800 Via Del Rey<br/>Bonita Springs, Florida 34134</p> <p><b>Contract Date:</b> February 14, 2008<br/><b>Final Contract Amount:</b> \$133,673.04<br/><b>Completion Date:</b> May 1, 2008</p> <p><b>Project Description:</b><br/>Installation of 14-inch force main, pump station and valve vault to existing CAT Operations Building.</p>   | <p><b>Project Name:</b> San Marco Master Lift Station</p> <p><b>Owner - Address - Project Manager - Phone:</b><br/>City of Marco Island<br/>Public Works<br/>50 Bald Eagle Drive<br/>Marco Island, Florida 34145<br/>Timothy E. Pinter, P.E.</p> <p><b>Engineer - Address - Phone:</b></p> <p><b>Contract Date:</b> January 2, 2008<br/><b>Final Contract Amount:</b> \$833,615.61<br/><b>Completion Date:</b></p> <p><b>Project Description:</b><br/>Construct new 800 GPM Master Lift Station</p>   |
| <p><b>Project Name:</b> Irrigation Quality Water Project</p> <p><b>Owner - Address - Project Manager:</b><br/>Collier County<br/>Facilities Management<br/>3301 Tamiami Trail East, Building W<br/>Naples, Florida 34112<br/>Damon Gonzales</p> <p><b>Engineer - Address - Phone:</b><br/>Anchor Engineering</p> <p><b>Contract Date:</b> March 14, 2007<br/><b>Final Contract Amount:</b> \$1,213,474.52<br/><b>Completion Date:</b> January 15, 2008</p> <p><b>Project Description:</b><br/>Irrigation improvements at Collier County Government Complex. Work was coordinated with an operating complex and interruptions were minimized or eliminated.</p>   | <p><b>Project Name:</b> Golden Gate WWTP and Injection Pump Station</p> <p><b>Owner - Address - Project Manager - Phone:</b><br/>Florida Governmental Utility Authority<br/>280 Wekiva Springs Road, Suite 203<br/>Longwood, Florida 32779</p> <p><b>Engineer - Address - Phone:</b><br/>Arcadis<br/>4307 Vineland Road<br/>Suite H-20<br/>Orlando, Florida 32811<br/>407-236-5700</p> <p><b>Contract Date:</b><br/><b>Final Contract Amount:</b><br/><b>Completion Date:</b><br/><b>Project Description:</b><br/>Expansion of Golden Gate WWTP which included the construction of a new digester, chlorine contact tank and injection well pump station, modification of clarifiers #1 and #2, installation of surge and annular pressure tanks and appurtenances.</p>     |
| <p><b>Project Name:</b> Treeline Master Pump Station</p> <p><b>Owner - Address - Project Manager - Phone:</b><br/>City of Fort Myers<br/>2200 Second Street<br/>Fort Myers, Florida 33902<br/>Eliana Hayes, E.I.<br/>(239) 332-6318</p> <p><b>Engineer - Address - Phone:</b><br/>Johnson Engineering, Inc.<br/>2122 Johnson Street<br/>Fort Myers, Florida 33920<br/>David Trouteau<br/>(239) 334-0046</p> <p><b>Contract Date:</b> July 1, 2008<br/><b>Final Contract Amount:</b> \$1,043,805.00 - Not Final<br/><b>Completion Date:</b> February, 2009</p> <p><b>Project Description:</b><br/>Installation of a master pump station located along Treeline Avenue. The project entailed a jack and bore under Treeline Avenue to connect to the existing force main and construction of a 20 foot deep master pump station. A 400 KW generator and odor control unit were also installed.</p> | <p><b>Project Name:</b> PS S-127 and S-133 Pump Refurbishment and Bearing Replace.</p> <p><b>Owner - Address - Project Manager - Phone:</b><br/>South Florida Water Management District<br/>2101 Centrepark West Drive, Suite 110<br/>West Palm Beach, Florida 33409<br/>Mike Curley</p> <p><b>Engineer - Address - Phone:</b><br/>South Florida Water Management District<br/>3301 Gun Club Road<br/>West Palm Beach, Florida 33408<br/>Terl Swartz</p> <p><b>Contract Date:</b> April 10, 2008<br/><b>Final Contract Amount:</b> \$3,947,723.00<br/><b>Completion Date:</b> July 2010</p> <p><b>Project Description:</b><br/>Completely recondition the main 42" vertical turbine pumps, five at S-127 and five at S-133. Install new electrical and instrumentation.</p> |

DOUGLAS N. HIGGINS, INC.  
EXPERIENCE - PAST EIGHT YEARS - GROUP 1

|  |  |
|--|--|
| <p><b>Project Name:</b> Gateway Triangle Stormwater Improvements</p> <p><b>Owner - Address - Project Manager - Phone:</b><br/>Collier County<br/>Stormwater Department<br/>2885 Horseshoe Drive<br/>Naples, Florida 34 239-252-8192<br/>Shane Cox</p> <p><b>Engineer - Address:</b><br/>HDR, Inc.<br/>200 West Forsyth Street<br/>Jacksonville, Florida 32202<br/>Laura Phillips</p> <p><b>Contract Date:</b> November 5, 2007<br/><b>Final Contract Amount:</b> \$1,021,336.78<br/><b>Completion Date:</b> July 28, 2008</p> <p><b>Project Description:</b><br/>Stormwater improvements to existing area - excavation of approximately 34,000 Cy of dirt and grading to form three continuous ponds. Installation of box culverts, sheet piling, concrete ditch pavement and storm drainage structures.</p> | <p><b>Project Name:</b> Marco Island North Barfield &amp; North Marco Sanitary Sewer District</p> <p><b>Owner - Address - Project Manager - Phone:</b><br/>City of Marco Island<br/>50 Bald Eagle Drive<br/>Marco Island, FL 34145<br/>Mr. James Miller<br/>239-389-5011</p> <p><b>Engineer - Address - Phone:</b><br/>Boyle Engineering<br/>4415 Metro Parkway, Suite 104<br/>Fort Myers, FL 33916<br/>Fred Mittl<br/>239-278-7996</p> <p><b>Contract Date:</b> March 1, 2007</p> <p><b>Final Contract Amount:</b> North Marco \$4,644,806.99<br/>North Barfield \$7,270,729.37<br/><b>Completion Date:</b> North Marco May 11, 2008<br/>North Barfield March 24, 2008</p> <p><b>Project Description:</b><br/>New wastewater collection system installed to replace existing septic tanks. Work included gravity sewer, forcemain, transmission main, pump stations, road restoration, etc.</p> |
| <p><b>Project Name:</b> NCWRF MLE Bleach Project Phase 2, Mechanical</p> <p><b>Owner - Address - Project Manager:</b><br/>Collier County<br/>Public Utilities Engineering Department<br/>3301 Tamiami Trail East, Building H<br/>Naples, Florida 34112<br/>Dianna Duerl</p> <p><b>Engineer - Address - Phone:</b><br/>Hole Montes<br/>950 Encore Way<br/>Naples, Florida 34110<br/>Jerry Taricska 239-254-2000</p> <p><b>Contract Date:</b> September 17, 2007<br/><b>Final Contract Amount:</b> \$336,412.49<br/><b>Completion Date:</b> June 17, 2008</p> <p><b>Project Description:</b><br/>Bleach piping modifications to chlorine contact chambers and modification of pump skids to have redundancy in bleach feed system.</p>   | <p><b>Project Name:</b> Rehabilitation of Master Pump Station 316</p> <p><b>Owner - Address - Project Manager:</b><br/>Collier County<br/>Public Utilities Engineering Department<br/>3301 Tamiami Trail East, Building H<br/>Naples, Florida 34112<br/>Sandy Sridhar</p> <p><b>Engineer - Address - Phone:</b><br/>Q. Grady Minor &amp; Associates<br/>3800 Via Del Rey<br/>Bonita Springs, Florida 34134<br/>David Schmitt<br/>239-947-1144</p> <p><b>Contract Date:</b> November 16, 2007<br/><b>Final Contract Amount:</b> \$765,823.34<br/><b>Completion Date:</b> June 3, 2008</p> <p><b>Project Description:</b><br/>Full rehab 800 GPM Master Pump Station</p>   |
| <p><b>Project Name:</b> Rehabilitation of Master Pump Station 318</p> <p><b>Owner - Address - Project Manager - Phone:</b><br/>Collier County<br/>Public Utilities Engineering Department<br/>3301 Tamiami Trail East, Building H<br/>Naples, Florida 34112<br/>Sandy Sridhar</p> <p><b>Engineer - Address - Phone:</b><br/>Q. Grady Minor &amp; Associates<br/>3800 Via Del Rey<br/>Bonita Springs, Florida 34134<br/>David Schmitt<br/>239-947-1144</p> <p><b>Contract Date:</b> October 9, 2007<br/><b>Final Contract Amount:</b> \$789,070.59<br/><b>Completion Date:</b> June 10, 2008</p> <p><b>Project Description:</b><br/>Fully rehab 3000 GPM Master Pump Station</p>  | <p><b>Project Name:</b> NCRWTP Chemical Laboratory Ventilation Improvements</p> <p><b>Owner - Address - Project Manager - Phone:</b><br/>Collier County<br/>Public Utilities Engineering Department<br/>3301 Tamiami Trail East, Building H<br/>Naples, Florida 34112<br/>Tom Chmelik<br/>239-732-2575</p> <p><b>Engineer - Address - Phone:</b><br/>TLC Engineering<br/>1400 Colonial Boulevard, Suite 203<br/>Fort Myers, Florida 33907<br/>Nicholas L. Mancuso<br/>239-275-4240</p> <p><b>Contract Date:</b> March 13, 2007<br/><b>Final Contract Amount:</b> \$749,367.67<br/><b>Completion Date:</b> November 30, 2008</p> <p><b>Project Description:</b><br/>Replace complete HVAC system including air handler, ductwork, exhaust fans, condenser and rehab fume hoods</p>  |

DOUGLAS N. HIGGINS, INC.  
EXPERIENCE - PAST EIGHT YEARS - GROUP 1

|   |   |
|---|---|
| <p><b>Project Name:</b> Connection to Water Main - Marco Shores</p> <p><b>Owner - Address - Project Manager:</b><br/>City of Marco Island<br/>Public Works<br/>50 Bald Eagle Drive<br/>Marco Island, Florida 34145<br/>James Miller</p> <p><b>Engineer - Address - Phone:</b></p> <p><b>Contract Date:</b> April 26, 2007<br/><b>Final Contract Amount:</b> \$188,000.00<br/><b>Completion Date:</b> August 31, 2007<br/><b>Project Description:</b><br/>Watermain connection at Marco Shores.</p>  | <p><b>Project Name:</b> Collier County NCRWTP AND SCRWTP Sand Separators</p> <p><b>Owner - Address - Project Manager - Phone:</b><br/>Collier County Public Utilities<br/>3301 East Tamiami Trail<br/>Naples, Florida 34112<br/>Diana Duerf</p> <p><b>Engineer - Address - Phone:</b><br/>Hazen and Sawyer</p> <p><b>Contract Date:</b> August 1, 2008<br/><b>Final Contract Amount:</b> In progress<br/><b>Completion Date:</b> In progress<br/><b>Project Description:</b><br/>Procurement and installation of two automatic self-cleaning sand separators (custom built in Germany) including stainless steel piping, valves, instruments and control panels. Installation of system, which included two, three-chamber pump stations, submersible pumps, venturi flowmeters, etc.</p>   |
| <p><b>Project Name:</b> SCRWTP Raw Water Transmission Main &amp; Appurtenances for Raw Water Wells 39S, 40S, 41S &amp; 42S</p> <p><b>Owner - Address - Project Manager - Phone:</b><br/>Collier County<br/>Public Utilities Engineering Department<br/>3301 Tamiami Trail, Building H<br/>Naples, Florida 34112<br/>Peter Schalt</p> <p><b>Engineer - Address - Phone:</b><br/>Hazen &amp; Sawyer<br/>2101 Corporate Boulevard, Suite 301<br/>Boca Raton, Florida 33431<br/>Albert Muniz<br/>561-997-8070</p> <p><b>Contract Date:</b> September 26, 2006<br/><b>Final Contract Amount:</b> \$1,884,000.00<br/><b>Completion Date:</b> April 11, 2007<br/><b>Project Description:</b><br/>Installed 3500 lf of 16-inch HDPE raw water transmission main along with four new raw water wells. This provided the plant the ability to produce sufficient capacity to meet water demands. Included installation of pigging stations and electrical enclosures.</p> | <p><b>Project Name:</b> Decommissioning of Pelican Bay Wastewater Treatment Plant</p> <p><b>Owner - Address - Project Manager - Phone:</b><br/>Collier County<br/>Public Utilities Engineering Department<br/>3301 Tamiami Trail East, Building H<br/>Naples, Florida 34112<br/>Sandy Sridhar</p> <p><b>Engineer - Address - Phone:</b><br/>Hazen and Sawyer<br/>2101 Corporate Boulevard, Suite 303<br/>Boca Raton, Florida 33431<br/>Kurt Pfeffer<br/>561-997-8070</p> <p><b>Contract Date:</b> February 8, 2006<br/><b>Final Contract Amount:</b> \$72,500.00<br/><b>Completion Date:</b> July 30, 2006<br/><b>Project Description:</b><br/>Decommissioning of an abandoned Wastewater Treatment Plant</p>   |
| <p><b>Project Name:</b> Pelican Bay Fire and Irrigation Water System Improvement at the Ritz Carlton</p> <p><b>Owner - Address - Project Manager:</b><br/>Collier County<br/>Public Utilities Engineering Department<br/>3301 Tamiami Trail East, Building H<br/>Naples, Florida 34112<br/>Claude Nesbitt</p> <p><b>Engineer - Address - Phone:</b><br/>Wilson Miller, Inc.<br/>3200 Bailey Lane, Suite 200<br/>Naples, Florida 34105<br/>Craig Pager<br/>800-649-4336</p> <p><b>Contract Date:</b> March 30, 2006<br/><b>Final Contract Amount:</b> \$162,723.43<br/><b>Completion Date:</b> February 28, 2007<br/><b>Project Description:</b><br/>Fire and Irrigation improvements for the Ritz Carlton. Work was coordinated to maintain fire safety at all times.</p>   | <p><b>Project Name:</b> Reclaimed Water Aquifer Storage and Recovery</p> <p><b>Owner - Address - Project Manager:</b><br/>Collier County<br/>Public Utilities Engineering Department<br/>3301 Tamiami Trail East, Building H<br/>Naples, Florida 34112<br/>Alicia Abbott</p> <p><b>Engineer - Address:</b><br/>Water Resource Solution<br/>1388 Colonial Boulevard<br/>Fort Myers, Florida 33907<br/>Lloyd Horvath</p> <p><b>Contract Date:</b> April 5, 2006<br/><b>Final Contract Amount:</b> \$4,658,515.28<br/><b>Completion Date:</b> June 6, 2007<br/><b>Project Description:</b><br/>Installed a deep injection well for the storage of reclaimed water coming from Collier County water treatment plants. The Owner will have full capability to recover this reclaimed water for market and/or use for their own irrigation needs.</p> |

DOUGLAS N. HIGGINS, INC.  
EXPERIENCE - PAST EIGHT YEARS - GROUP 1

|   |   |
|---|---|
| <p><b>Project Name:</b> Tigertall Sewer District<br/>Wastewater Collection System Expansion</p> <p><b>Owner - Address - Project Manager - Phone:</b><br/>City of Marco Island<br/>50 Bald Eagle Drive<br/>Marco Island, FL 34145<br/>Mr. James Miller<br/>239-389-5011</p> <p><b>Engineer - Address - Phone:</b><br/>Boyle Engineering<br/>4415 Metro Parkway, Suite 104<br/>Fort Myers, FL 33916<br/>Fred Mittl<br/>239-278-7996</p> <p><b>Contract Date:</b> March 7, 2006<br/><b>Final Contract Amount:</b> \$2,920,703.33<br/><b>Completion Date:</b> December 21, 2006<br/><b>Project Description:</b><br/>New wastewater collection system including gravity sewer, forcemaln, transmission mains, laterals, pump stations, and complete road restoration</p> | <p><b>Project Name:</b> Pads for MBR and Equipment</p> <p><b>Owner - Address - Project Manager - Phone:</b><br/>City of Marco Island<br/>50 Bald Eagle Drive<br/>Marco Island, FL 34145<br/>Mr. Bruce Weinstein<br/>239-389-5182</p> <p><b>Engineer - Address - Phone:</b><br/>CDM<br/>9311 College Parkway<br/>Fort Myers, FL 33919<br/>Adam Soblenski<br/>239-437-9494</p> <p><b>Contract Date:</b> March 13, 2006<br/><b>Final Contract Amount:</b> \$183,000.00<br/><b>Completion Date:</b> May 13, 2006<br/><b>Project Description:</b><br/>Four structural concrete slabs.</p>  |
| <p><b>Project Name:</b> Rosemary Park Paving &amp; Drainage Improvements</p> <p><b>Owner - Address - Project Manager - Phone:</b><br/>City of Bonita Springs<br/>Public Works Department<br/>9101 Bonita Beach Road<br/>Bonita Springs, Florida<br/>239-949-6243</p> <p><b>Engineer - Address - Phone:</b><br/>Q. Grady Minor<br/>3800 Via Del Rey<br/>Bonita Springs 34134<br/>David Schmitt<br/>239-949-6243</p> <p><b>Contract Date:</b> April 5, 2006<br/><b>Final Contract Amount:</b> \$831,805.33<br/><b>Completion Date:</b> November 1, 2006<br/><b>Project Description:</b><br/>Drainage improvements with RCP pipe and concrete structures.</p>  | <p><b>Project Name:</b> Forest Lakes MSTU<br/>Phase 2 Drainage Improvements</p> <p><b>Owner - Address - Project Manager - Phone:</b><br/>Collier County - ATM<br/>Stormwater Department<br/>2885 Horseshoe Drive South<br/>Naples, Florida 34104<br/>Darryl Richard</p> <p><b>Engineer - Address:</b><br/>Wilson Miller<br/>3200 Bailey Lane, Suite 200<br/>Naples, Florida 34105<br/>Craig Pajer</p> <p><b>Contract Date:</b> May 2, 2006<br/><b>Final Contract Amount:</b> \$193,287.00<br/><b>Completion Date:</b> July 19, 2006<br/><b>Project Description:</b><br/>Drainage improvements with RCP and concrete structures.</p>   |
| <p><b>Project Name:</b> Dorch Ave, Drainage &amp; Paving Impvs.<br/>Hampton Street Sidewalk Improvements</p> <p><b>Owner - Address - Project Manager - Phone:</b><br/>City of Bonita Springs<br/>Public Works Department<br/>9101 Bonita Beach Road<br/>Bonita Springs, Florida<br/>239-949-6243</p> <p><b>Engineer - Address - Phone:</b><br/>Q. Grady Minor<br/>3800 Via Del Rey<br/>Bonita Springs 34134<br/>David Schmitt<br/>239-949-6243</p> <p><b>Contract Date:</b> March 15, 2006<br/><b>Final Contract Amount:</b> \$316,400.50<br/><b>Completion Date:</b> August 1, 2006<br/><b>Project Description:</b><br/>Drainage improvements with RCP pipe and concrete structures.</p>   | <p><b>Project Name:</b> Lehigh Acres Interconnect<br/>with The City of Fort Myers</p> <p><b>Owner - Address - Project Manager - Phone:</b><br/>Florida Governmental Utility Authority<br/>280 Wekiva Springs Road, Suite 203<br/>Longwood, Florida 32779</p> <p><b>Engineer - Address - Phone:</b><br/>Malcom Pirnie, Inc.<br/>2301 Maitland Center Parkway, Suite 425<br/>Maitland, Florida 32751<br/>Victor Hurlburt<br/>407-659-5550</p> <p><b>Contract Date:</b> June 15, 2006<br/><b>Final Contract Amount:</b> \$2,884,382.00<br/><b>Completion Date:</b> April 2007<br/><b>Project Description:</b><br/>New 8" and 12" watermain including both open cut and directional drilling. Work was performed along a busy thoroughfare.</p> |



DOUGLAS N. HIGGINS, INC.  
EXPERIENCE - PAST EIGHT YEARS - GROUP 1

|  |  |
|--|--|
| <p><b>Project Name:</b> Pump Station 109 and 113 Improvements</p> <p><b>Owner - Address - Project Manager - Phone:</b><br/>Collier County<br/>Public Utilities Engineering<br/>3301 Tamiami Trail East, Building H<br/>Sandy Sridhar</p> <p><b>Engineer - Address - Phone:</b><br/>Q. Grady Minor &amp; Associates<br/>3800 Via Del Rey<br/>Bonita Springs, Florida 34134<br/>David Schmitt</p> <p><b>Contract Date:</b> February 8, 2006<br/><b>Final Contract Amount:</b> \$ 1,229,561.25<br/><b>Completion Date:</b> September 29, 2006</p> <p><b>Project Description:</b><br/>New Pump Station &amp; Complete Pump Station Rehab. Work included bypass pumping, structural concrete, precast concrete, electrical/instrumentation, and mechanical.</p> | <p><b>Project Name:</b> Marco Island Wastewater Treatment Plant Expansion - Phase 1 Improvements</p> <p><b>Owner - Address - Project Manager - Phone:</b><br/>City of Marco Island<br/>50 Bald Eagle Drive<br/>Marco Island, FL 34145<br/>Mr. Bruce Weinstein<br/>239-389-5182</p> <p><b>Engineer - Address - Phone:</b><br/>CDM<br/>9311 College Parkway<br/>Fort Myers, FL 33919<br/>Adam Soblenski<br/>239-437-9494</p> <p><b>Contract Date:</b> May 23, 2006<br/><b>Final Contract Amount:</b> \$9,787,283.47<br/><b>Completion Date:</b> January 17, 2007</p> <p><b>Project Description:</b> Included in similar project section</p>  |
| <p><b>Project Name:</b> Appurtenances For Wells RO 101N and 102N</p> <p><b>Owner - Address - Project Manager - Phone:</b><br/>Collier County<br/>Public Utilities Engineering<br/>3301 Tamiami Trail East, Building H<br/>Naples, Florida 34112<br/>Peter Schall</p> <p><b>Engineer - Address - Phone:</b><br/>Hazen &amp; Sawyer<br/>2101 Corporate Boulevard, Suite 301<br/>Boca Raton, Florida 33431<br/>Albert Muniz</p> <p><b>Contract Date:</b> May 24, 2005<br/><b>Final Contract Amount:</b> \$597,000.00<br/><b>Completion Date:</b> January 27, 2006</p> <p><b>Project Description:</b><br/>Complete well installations with exception of the drilled well including pumps, mechanical, and electrical/instrumentation</p>                       | <p><b>Project Name:</b> Construction of Wells 35 &amp; 36</p> <p><b>Owner - Address - Project Manager - Phone:</b><br/>Collier County<br/>Public Utilities Engineering<br/>3301 Tamiami Trail East, Building H<br/>Howard Brogdon</p> <p><b>Engineer - Address - Phone:</b><br/>Camp Dresser &amp; McKee, Inc.<br/>9311 College Parkway, Suite 1<br/>Fort Myers, Florida 33919<br/>Adam Sobolewski<br/>239-432-9494</p> <p><b>Contract Date:</b> August 16, 2005<br/><b>Final Contract Amount:</b> \$998,980.97<br/><b>Completion Date:</b> January 30, 2006</p> <p><b>Project Description:</b><br/>Complete well installations with exception of the drilled well including pumps, mechanical, and electrical/instrumentation</p> |
| <p><b>Project Name:</b> 12th Avenue Interconnect Booster PS</p> <p><b>Owner - Address - Project Manager - Phone:</b><br/>Collier County<br/>Public Utilities Engineering<br/>3301 Tamiami Trail East, Building H<br/>Naples, Florida 34112<br/>Peter Schall</p> <p><b>Engineer - Address - Phone:</b><br/>Hazen and Sawyer<br/>1905 South 25th Street, Suite 103<br/>Fort Pierce, Florida 34947<br/>Albert Muniz</p> <p><b>Contract Date:</b> August 8, 2005<br/><b>Final Contract Amount:</b> \$1,083,000.00<br/><b>Completion Date:</b> October 31, 2006</p> <p><b>Project Description:</b> New Wellfield Booster Pump Station including structural concrete, a precast building, mechanical piping, major electrical and instrumentation.</p>           | <p><b>Project Name:</b> NCWRF Rebuild filter Set 1<br/>Clean and Paint Filter Beds</p> <p><b>Owner - Address - Project Manager - Phone:</b><br/>Collier County<br/>Public Utilities Engineering Department<br/>3301 Tamiami Trail East, Building H<br/>Karen Gullian</p> <p><b>Engineer - Address - Phone:</b><br/>Collier County<br/>Public Utilities Engineering Department<br/>3301 Tamiami Trail East, Building H<br/>Karen Gullian</p> <p><b>Contract Date:</b> March 1, 2005<br/><b>Final Contract Amount:</b> \$354,817.00<br/><b>Completion Date:</b> September 14, 2005</p> <p><b>Project Description:</b><br/>Clean out existing filter beds, paint, and install new filter sand.</p>                                    |

DOUGLAS N. HIGGINS, INC.  
EXPERIENCE - PAST EIGHT YEARS - GROUP 1

|  |  |
|--|--|
| <p><b>Project Name:</b> SCWRF Rehabilitation Piping Odor Control Modifications</p> <p><b>Owner - Address - Project Manager - Phone:</b><br/>Collier County<br/>Public Utilities Engineering<br/>3301 Tamiami Trail East, Building H<br/>Naples, Florida 34112<br/>Vaughn Williams</p> <p><b>Engineer - Address - Phone:</b><br/>Hole Montes<br/>950 Encore Way<br/>Naples, Florida 34110<br/>E. Joseph Goetz, Jr.<br/>239-254-2000</p> <p><b>Contract Date:</b> November 21, 2005<br/><b>Final Contract Amount:</b> \$217,900.00<br/><b>Completion Date:</b> July 12, 2006<br/><b>Project Description:</b><br/>Modifications to the existing Odor Control System</p> | <p><b>Project Name:</b> Michigan Street Drainage Improvements</p> <p><b>Owner - Address - Project Manager - Phone:</b><br/>City of Bonita Springs<br/>9101 Bonita Beach Road<br/>Bonita Springs, Florida 34135<br/>239-949-6262</p> <p><b>Engineer - Address - Phone:</b><br/>Q. Grady Minor &amp; Associates<br/>3800 Via Del Rey<br/>Bonita Springs, Florida 34134<br/>David Schmitt</p> <p><b>Contract Date:</b> January 10, 2005<br/><b>Final Contract Amount:</b> \$243,610.00<br/><b>Completion Date:</b> September 1, 2005<br/><b>Project Description:</b><br/>Drainage improvements with RCP pipe and concrete structures.</p>   |
| <p><b>Project Name:</b> Richview Court Drainage Maintenance</p> <p><b>Owner - Address - Project Manager - Phone:</b><br/>City of Bonita Springs<br/>Public Works Department<br/>9101 Bonita Beach Road<br/>Bonita Springs, Florida<br/>239-949-6243</p> <p><b>Engineer - Address - Phone:</b><br/>City of Bonita Springs<br/>Public Works Department</p> <p><b>Contract Date:</b> December 27, 2005<br/><b>Final Contract Amount:</b> \$29,333.50<br/><b>Completion Date:</b> January 30, 2006<br/><b>Project Description:</b><br/>Drainage improvements with RCP pipe and concrete structures.</p>  | <p><b>Project Name:</b> I-75 and Alico Road Interchange Reconstr.</p> <p><b>Owner - Address - Project Manager - Phone:</b><br/>Florida Department of Transportation<br/>Tallahassee, Florida</p> <p><b>Engineer - Address - Phone:</b><br/>Contractor: Engineer: Thomas Boyle<br/>Kiewit Southern 239-432-2732<br/>450 Dividend Drive 16999 James Whiteshead Road<br/>Peachtree City, Georgia Fort Myers, Florida 33912</p> <p><b>Contract Date:</b> October 5, 2005<br/><b>Final Contract Amount:</b> \$1,288,742.63<br/><b>Completion Date:</b> June 2007<br/><b>Project Description:</b><br/>Installed 12,000 LF of 36" Ductile Iron Pipe including jack &amp; bores, and all testing. Work was performed as a subcontractor.</p> |
| <p><b>Project Name:</b> Culvert Replacement in the River Oaks, Palm River Subdivision</p> <p><b>Owner - Address - Project Manager - Phone:</b><br/>Collier County<br/>Stormwater Management<br/>2885 Horseshoe Drive<br/>Naples, Florida 34104<br/>Margaret Bishop</p> <p><b>Engineer - Address - Phone:</b><br/>Collier County<br/>Stormwater Management</p> <p><b>Contract Date:</b> April 4, 2005<br/><b>Final Contract Amount:</b> \$576,642.50<br/><b>Completion Date:</b> July 8, 2005<br/><b>Project Description:</b><br/>Drainage improvements with RCP pipe and concrete structures.</p>  | <p><b>Project Name:</b> Twin Lakes Interconnect</p> <p><b>Owner - Address - Project Manager - Phone:</b><br/>Collier County<br/>Stormwater Management<br/>2885 Horseshoe Drive<br/>Naples, Florida 34104<br/>Gianfranco Nicolaci</p> <p><b>Engineer - Address - Phone:</b><br/>Agnoli Barber &amp; Brundage, Inc.<br/>7400 Tamiami Trail North, Suite 200<br/>Naples, Florida 34108<br/>Roger Sandrus</p> <p><b>Contract Date:</b> September 12, 2005<br/><b>Final Contract Amount:</b> \$750,120.76<br/><b>Completion Date:</b> March 1, 2006<br/><b>Project Description:</b><br/>Drainage improvements with RCP pipe and concrete structures.</p>  |

FLORIDA BID BOND

BOND NO. \_\_\_\_\_

AMOUNT: \$ 5%

KNOW ALL MEN BY THESE PRESENTS, that Douglas N. Higgins, Inc.

hereinafter called the PRINCIPAL, and Hartford Accident and Indemnity Company

a corporation duly organized under the laws of the State of CT

having its principal place of business at P.O. Box 2103, 690 Asylum Ave., Hartford

CT 06115 in the State of CT

and authorized to do business in the State of Florida, as SURETY, are held and firmly bound

unto City of Key West

hereinafter called the OBLIGEE, in the sum of five percent of attached bid

DOLLARS (\$ 5%) for the payment for which we bind ourselves, our heirs, executors, administrators, successors, and assigns, jointly and severally, firmly by these present.

THE CONDITION OF THIS BOND IS SUCH THAT:

WHEREAS, the PRINCIPAL is herewith submitting his or its Bid Proposal for GN 0711, COLLEGE ROAD ENHANCEMENTS, OVERSEAS HIGHWAY TO KOKENZIE ROAD, Key West, Florida said Bid Proposal, by reference thereto, being hereby made a part hereof.

WHEREAS, the PRINCIPAL contemplates submitting or has submitted a bid to the OBLIGEE for the furnishing of all labor, materials (except those to be specifically furnished by the Owner), equipment, machinery, tools, apparatus, means of transportation for, and the performance of the work covered in the Proposal and the detailed Drawings and Specifications, entitled:

GN 0711, COLLEGE ROAD ENHANCEMENTS, OVERSEAS HIGHWAY TO KOKENZIE ROAD, Key West, Florida.

WHEREAS, it was a condition precedent to the submission of said bid that a cashier's check, certified check, or bid bond in the amount of 5 percent of the base bid be submitted with said bid as a guarantee that the Bidder would, if awarded the Contract, enter into a written Contract with the Owner for the performance of said Contract, within 10 working days after written notice having been given of the award of the Contract.

NOW, THEREFORE, the conditions of this obligation are such that if the PRINCIPAL within 10 consecutive calendar days after written notice of such acceptance, enters into a written Contract with the OBLIGEE and furnishes the Performance and Payment Bonds, each in an amount equal to 100 percent of the base bid, satisfactory to the Owner, then this obligation shall be void; otherwise the sum herein stated shall be due and payable to the OBLIGEE and the Surety herein agrees to pay said sum immediately upon demand of the OBLIGEE in good and lawful money of the United States of America, as liquidated damages for failure thereof of said PRINCIPAL.

Signed and sealed this 30th day of March, 2011.

PRINCIPAL Douglas N. Higgins, Inc.

By Kelly A. Wilkie  
Kelly A. Wilkie, Vice-President

SURETY Hartford Accident and Indemnity Company

By Heather M. Johnson  
Attorney-In-Fact Heather M. Johnson

Dale A. Bell

Dale A. Bell  
FL Resident Agent  
Sells & Co. 2001 NW 37th Ave.  
Miami, FL 33172 305 661 1099

\* \* \* \* \*

# POWER OF ATTORNEY

Direct Inquiries/Claims to:

THE HARTFORD  
BOND, T-4  
P.O. BOX 2103, 690 ASYLUM AVENUE  
HARTFORD, CONNECTICUT 06115

call: 888-266-3488 or fax: 860-757-5835

Agency Code: 35-350851

KNOW ALL PERSONS BY THESE PRESENTS THAT:

- Hartford Fire Insurance Company, a corporation duly organized under the laws of the State of Connecticut
- Hartford Casualty Insurance Company, a corporation duly organized under the laws of the State of Indiana
- Hartford Accident and Indemnity Company, a corporation duly organized under the laws of the State of Connecticut
- Hartford Underwriters Insurance Company, a corporation duly organized under the laws of the State of Connecticut
- Twin City Fire Insurance Company, a corporation duly organized under the laws of the State of Indiana
- Hartford Insurance Company of Illinois, a corporation duly organized under the laws of the State of Illinois
- Hartford Insurance Company of the Midwest, a corporation duly organized under the laws of the State of Indiana
- Hartford Insurance Company of the Southeast, a corporation duly organized under the laws of the State of Florida

having their home office in Hartford, Connecticut, (hereinafter collectively referred to as the "Companies") do hereby make, constitute and appoint, **up to the amount of unlimited:**

*Dan Hines, Heather M. Johnson, Judy K. Macklem, Carol J. Youngs*  
of  
*Ann Arbor, MI*

their true and lawful Attorney(s)-in-Fact, each in their separate capacity if more than one is named above, to sign its name as surety(ies) only as delineated above by , and to execute, seal and acknowledge any and all bonds, undertakings, contracts and other written instruments in the nature thereof, on behalf of the Companies in their business of guaranteeing the fidelity of persons, guaranteeing the performance of contracts and executing or guaranteeing bonds and undertakings required or permitted in any actions or proceedings allowed by law.

In Witness Whereof, and as authorized by a Resolution of the Board of Directors of the Companies on January 22, 2004 the Companies have caused these presents to be signed by its Assistant Vice President and its corporate seals to be hereto affixed, duly attested by its Assistant Secretary. Further, pursuant to Resolution of the Board of Directors of the Companies, the Companies hereby unambiguously affirm that they are and will be bound by any mechanically applied signatures applied to this Power of Attorney.



*Paul A. Bergenholtz*

Paul A. Bergenholtz, Assistant Secretary

*M. Ross Fisher*

M. Ross Fisher, Assistant Vice President

STATE OF CONNECTICUT }  
COUNTY OF HARTFORD } ss. Hartford

On this 3rd day of March, 2008, before me personally came M. Ross Fisher, to me known, who being by me duly sworn, did depose and say: that he resides in the County of Hartford, State of Connecticut; that he is the Assistant Vice President of the Companies, the corporations described in and which executed the above instrument; that he knows the seals of the said corporations; that the seals affixed to the said instrument are such corporate seals; that they were so affixed by authority of the Boards of Directors of said corporations and that he signed his name thereto by like authority.



CERTIFICATE

*Scott E. Paseka*

Scott E. Paseka  
Notary Public

My Commission Expires October 31, 2012

I, the undersigned, Assistant Vice President of the Companies, DO HEREBY CERTIFY that the above and foregoing is a true and correct copy of the Power of Attorney executed by said Companies, which is still in full force effective as of March 30, 2011.

Signed and sealed at the City of Hartford.



*Gary W. Stumper*

Gary W. Stumper, Assistant Vice President

ANTI-KICKBACK AFFIDAVIT

STATE OF ~~FLORIDA~~ Michigan

SS:

COUNTY OF ~~MONROE~~ Washtenaw

THIS FORM MUST BE SIGNED AND SWORN TO IN THE PRESENCE OF A NOTARY PUBLIC OR OTHER OFFICIAL AUTHORIZED TO ADMINISTER OATHS,

This sworn statement is submitted to the City of Key West, Florida, by Kelly A. Wilkie, Vice-President (print individual's name and title)  
for Douglas N. Higgins, Inc  
(print name of entity submitting sworn statement)

whose business address is 3390 Travis Pointe Rd. Suite A Ann Arbor, MI 48108  
and (if applicable) its Federal Employer Identification Number (FEIN) is

38-1807765 (if the entity has no FEIN, include the Social Security Number of the individual signing this sworn statement):

I, the undersigned, being hereby duly sworn, depose and say that no sum has been paid and no sum will be paid to any employee or elected official of the City of Key West as a commission, kickback, reward or gift, directly or indirectly, by me or any member of my firm, or by any officer or agent of the corporation.

BY: Kelly A. Wilkie  
TITLE: Vice-President

sworn and prescribed before me this 30th day of March, 2011

R. Suzanne Hawker  
NOTARY PUBLIC, State of ~~Florida~~  
My commission expires: Michigan

**R. SUZANNE HAWKER**  
Notary Public, Washtenaw County, MI  
My Commission Expires Mar 7, 2017

PUBLIC ENTITY CRIMES CERTIFICATION

THIS FORM MUST BE SIGNED AND SWORN TO IN THE PRESENCE OF A NOTARY PUBLIC OR OTHER OFFICIAL AUTHORIZED TO ADMINISTER OATHS,

- 1. This sworn statement is submitted to the City of Key West, Florida, by Kelly A. Mikie, Vice-President (print individual's name and title) for Douglas N. Higgins, Inc. (print name of entity submitting sworn statement)

whose business address is 3390 Travis Pointe Rd. Suite A Ann Arbor, MI 48108  
 and (if applicable) its Federal Employer Identification Number (FEIN) is  
381807765 (If the entity has no FEIN, include the Social Security Number of the individual signing this sworn statement \_\_\_\_\_):

- 2. I understand that a "public entity crime" as defined in Paragraph 287.133(1)(g), Florida Statutes, means a violation of any state or federal law by a person with respect to and \_\_\_\_\_ directly related to the transaction of business with any public entity or with an agency or \_\_\_\_\_ political subdivision of any other state or of the United States, including, but not limited to, any bid or contract for goods or services to be provided to any public entity or an agency or political subdivision of any other state or of the United States and involving antitrust, fraud, theft, bribery, collusion, racketeering, conspiracy, or material misrepresentation.
- 3. I understand that "conviction" as defined in Paragraph 287.133(1)(g), Florida Statutes, means a finding of guilt or a conviction of a public entity crime, with or without an adjudication of guilt, in any federal or state trial court of record relating to charges brought by indictment or information after July 1, 1989, as a result of a jury verdict, nonjury trial, or entry of a plea of guilty or nolo contendere.
- 4. I understand that an "affiliate" as defined in Paragraph 287.133(1)(a), Florida Statutes, means:
  - 1. A predecessor or successor of a person convicted of a public entity crime: or
  - 2. An entity under the control of any natural person who is active in the management of the entity and who has been convicted of a public entity crime. The term "affiliate" includes those officers, directors, executives, partners, shareholders, employees, members and agents who are active in the management of an affiliate. The ownership by one person of shares constituting a controlling interest in another person, \_\_\_\_\_ or a pooling of equipment of income among persons when not for fair market value under an arm's length agreement, shall be a prima facie case that one person controls another person. A person who knowingly enters into a joint venture with a person who has been convicted of a public entity crime in Florida during the preceding 36 months shall be considered an affiliate.
- 5. I understand that a "person" as defined in Paragraph 287.133(1)(e), Florida Statutes, means any natural person or entity organized under the laws of any state or of the United States with the legal power to enter into a binding contract and which bids or applies to bid on contracts for the provision of goods or services let by a public entity, or which otherwise transacts or applies to transact business with a public entity. The term "person" includes those officers, directors, executives, partners, shareholders, employees, members, and agents who are active in management of an entity.
- 6. Based on information and belief, the statement which I have marked below is true in relation to the entity submitting this sworn statement (indicate which statement applies).

Neither the entity submitting this sworn statement, or any of its officers, directors, executives, partners, shareholders, employees, members, or agents who are active in the management of the entity, nor any affiliate of the entity has been charged with and convicted of a public entity crime subsequent to July 1, 1989.

\_\_\_ The entity submitting this sworn statement, or one or more of its officers, directors, executives, partners, shareholders, employees, members, or agents who are active in the management of the entity, or an affiliate of the entity has been charged with and convicted of a public entity crime subsequent to July 1, 1989.

\_\_\_ The entity submitting this sworn statement, or one or more of its officers, directors, executives, partners, shareholders, employees, members, or agents who are active in the management of the entity, or an affiliate of the entity has been charged with and convicted of a public entity crime subsequent to July 1, 1989. However, there has been a subsequent proceeding before an Administrative Law Judge of the State of Florida, Division of Administrative Hearings and the Final Order entered by the Administrative Law Judge determined that it was not in the public interest to place the entity submitting this sworn statement on the convicted vendor list. (attach a copy of the final order)

I UNDERSTAND THAT THE SUBMISSION OF THIS FORM TO THE CONTRACTING OFFICER FOR THE PUBLIC ENTITY IDENTIFIED IN PARAGRAPH ONE (1) ABOVE IS FOR THAT PUBLIC ENTITY ONLY AND, THAT THIS FORM IS VALID THROUGH DECEMBER 31 OF THE CALENDAR YEAR IN WHICH IT IS FILED. I ALSO UNDERSTAND THAT I AM REQUIRED TO INFORM THE PUBLIC ENTITY PRIOR TO ENTERING INTO A CONTRACT IN EXCESS OF THE THRESHOLD AMOUNT PROVIDED IN SECTION 287.017, FLORIDA STATUTES, FOR CATEGORY TWO OF ANY CHANGE IN THE INFORMATION CONTAINED IN THIS FORM.

Kelly A. Wilkie (SIGNATURE)  
3/30/2011  
(DATE)

STATE OF Michigan  
COUNTY OF Washtenaw

PERSONALLY APPEARED BEFORE ME, the undersigned authority Kelly A. Wilkie who, after first being sworn by me, Kelly A. Wilkie (name of individual) affixed his/her signature in the space provided above on this 30th day of March, 2011.

R. Suzanne Hawker  
NOTARY PUBLIC

Printed Name **R. SUZANNE HAWKER**  
**Notary Public, Washtenaw County, MI**  
**My Commission Expires Mar 7, 2017**

My commission expires:



SUSPENSION AND DEBARMENT CERTIFICATION

CERTIFICATION REGARDING DEBARMENTS, SUSPENSION, INELIGIBILITY AND VOLUNTARY EXCLUSION-LOWER TIER FEDERALLY FUNDED TRANSACTIONS

1. The undersigned hereby certifies that neither it nor its principals is presently debarred, suspended, proposed for debarment, declared ineligible, or voluntarily excluded from participation in this transaction by any Federal department or agency.

2. The undersigned also certifies that it and its principals:

(a) Have not within a three-year period preceding this certification been convicted of or had a civil judgment rendered against them for commission of fraud or a criminal offense in connection with obtaining, attempting to obtain, or performing a public (Federal, State or local) transaction or contract under a public transaction; violation of Federal or State anti-trust statutes or commission of embezzlement, theft, forgery, bribery, falsification or destruction of records, making false statements, or receiving stolen property.

(b) Are not presently indicted for or otherwise criminally or civilly charged by a governmental entity (Federal, State or local) with commission of any of the offenses enumerated in paragraph 2.(a) of this Certification; and

(c) Have not within a three-year period preceding this certification had one or more public transactions (Federal, State or local) terminated for cause or default.

3. Where the undersigned is unable to certify to any of the statements in this certification, an explanation shall be attached to this certification.

Dated this 30th day of March, 2011.

By Kelly A. Wilkie  
Authorized Signature/Contractor

Kelly A. Wilkie, Vice-President  
Typed Name/Title

Douglas N. Higgins, Inc.  
Contractor's Firm Name

3390 Travis Pointe Rd.  
Street Address

Suite A  
Building, Suite Number

Ann Arbor, MI 48108  
City/State/Zip Code

(734) 996-9500  
Area Code/Telephone Number

DISCLOSURE OF LOBBYING ACTIVITIES

*not applicable*

Complete this form to disclose lobbying activities pursuant to 31 U.S.C. 1352  
(See reverse for public burden disclosure.)

|  |   |  |
|--|---|--|
| <p><b>1. Type of Federal Action:</b></p> <input type="checkbox"/> <ul style="list-style-type: none"> <li>a. contract</li> <li>b. grant</li> <li>c. cooperative agreement</li> <li>d. loan</li> <li>e. loan guarantee</li> <li>f. loan insurance</li> </ul> | <p><b>2. Status of Federal Action:</b></p> <input type="checkbox"/> <ul style="list-style-type: none"> <li>a. bid/offer/application</li> <li>b. initial award</li> <li>c. post-award</li> </ul> | <p><b>3. Report Type:</b></p> <input type="checkbox"/> <ul style="list-style-type: none"> <li>a. initial filing</li> <li>b. material change</li> </ul> <p><b>For Material Change Only:</b></p> <p>year _____</p> <p>quarter _____</p> <p>date of last report _____</p> |
| <p><b>4. Name and Address of Reporting Entity:</b></p> <input type="checkbox"/> Prime <input type="checkbox"/> Subawardee<br>Tier _____, <i>if known:</i> <p>Congressional District, <i>if known:</i></p>  |   | <p><b>5. If Reporting Entity in No. 4 is Subawardee, Enter Name and Address of Prime:</b></p> <p>Congressional District, <i>if known:</i></p>  |
| <p><b>6. Federal Department/Agency:</b></p>  | <p><b>7. Federal Program Name/Description:</b></p> <p>CFDA Number, <i>if applicable:</i></p> <p>_____</p>   |  |
| <p><b>8. Federal Action Number, <i>if known:</i></b></p>   | <p><b>9. Award Amount, <i>if known:</i></b></p> <p>\$</p>   |  |
| <p><b>10. a. Name and Address of Lobbying Entity</b><br/><i>(if individual, last name, first name, MI):</i></p>  | <p><b>b. Individuals Performing Services</b> <i>(including address if different from No. 10a)</i><br/><i>(last name, first name, MI):</i></p>   |  |
| <p align="center"><i>(attach Continuation Sheet(s) SF-LLA, if necessary)</i></p> <p><b>11. Information requested through this form is</b>      <b>Signature:</b></p>   |   |  |

authorized by title 31 U.S.C. section 1352. This disclosure of lobbying activities is a material representation of fact upon which reliance was placed by the tier above when this transaction was made or entered into. This disclosure is required pursuant to 31 U.S.C. 1352. This information will be reported to Congress semi-annually and will be available for public inspection. Any person who fails to file the required disclosure shall be subject to a civil penalty of not less than \$10,000 and not more than \$100,000 for each such failure.

Print Name: \_\_\_\_\_

Title: \_\_\_\_\_

Telephone No.: \_\_\_\_\_

Date: \_\_\_\_\_

Federal Use Only:

Authorized for Local Reproduction  
Standard Form – LLL (Rev 7 – 97)

Form DEP 55-221 (01/01)

## INSTRUCTIONS FOR COMPLETION OF SELF DISCLOSURE OF LOBBYING ACTIVITIES

This disclosure form shall be completed by the reporting entity, whether subawardee or prime Federal recipient, at the initiation or receipt of a covered Federal action, or a material change to a previous filing, pursuant to title 31 U.S.C. section 1352. The filing of a form is required for each payment or agreement to make payment to any lobbying entity for influencing or attempting to influence an officer or employee of any agency, a Member of Congress, an officer or employee of Congress, or an employee of a Member of Congress in connection with a covered Federal action. Complete all items that apply for both the initial filing and material change report. Refer to the implementing guidance published by the Office of Management and Budget for additional information.

1. Identify the type of covered Federal action for which lobbying activity is and/or has been secured to influence the outcome of a covered Federal action.
2. Identify the status of the covered Federal action.
3. Identify the appropriate classification of this report. If this is a follow up report caused by a material change to the information previously reported, enter the year and quarter in which the change occurred. Enter the date of the last previously submitted report by the reporting entity for this covered Federal action.
4. Enter the full name, address, city, state and zip code of the reporting entity. Include Congressional District, if known. Check the appropriate classification of the reporting entity that designates if it is or expects to be, a prime or subaward recipient. Identify the tier of the subawardee, e.g., the first subawardee of the prime is the 1st tier. Subawards include but are not limited to subcontracts, subgrants and contract awards under grants.
5. If the organization filing the report in item 4 checks "Subawardee", then enter the full name, address, city, state and zip code of the prime Federal recipient. Include Congressional District, if known.
6. Enter the name of the Federal agency making the award or loan commitment. Include at least one organizational level below agency name, if known. For example, Department of Transportation, United States Coast Guard.
7. Enter the Federal program name or description for the covered Federal action (item 1). If known, enter the full Catalog of Federal Domestic Assistance (CFDA) number for grants, cooperative agreements, loans, and loan commitments.
8. Enter the most appropriate Federal identifying number available for the Federal action identified in item 1 (e.g., Request for Proposal (RFP) number; Invitation for Bid (IFB) number; grant announcement number; the contract, grant, or loan award number; the application/proposal control number assigned by the Federal agency). Include prefixes, e.g., "RFP-DE-90-001."
9. For a covered Federal action where there has been an award or loan commitment by the Federal agency, enter the Federal amount of the award/loan commitment for the prime entity identified in item 4 or 5.
10. (a) Enter the full name, address, city, state and zip code of the lobbying entity engaged by the reporting entity identified in item 4 to influence the covered Federal action.  
  
(b) Enter the full names of the individual(s) performing services, and include full address if different from 10 (a). Enter Last Name, First Name, and Middle Initial (MI).
11. The certifying official shall sign and date the form, print his/her name, title and telephone number.

According to the Paperwork Reduction Act, as amended, no persons are required to respond to a collection of information unless it displays a valid OMB Control Number. The valid OMB control number for this information collection is OMB No. 0348-0046. Public reporting burden for this collection of information is estimated to average 30 minutes per response, including time for reviewing instructions, searching existing data sources, gathering and maintaining the data needed, and completing and reviewing the collection of information. Send comments regarding the burden estimate or any other aspect of this collection of information, including suggestions for reducing this burden, to the Office of Management and Budget, Paperwork Reduction Project (0348-0046), Washington, D.C. 20503.

**NON-COLLUSION DECLARATION AND  
COMPLIANCE WITH 49 CFR §29.**  
STATE OF FLORIDA DEPARTMENT OF TRANSPORTATION

ITEM/SEGMENT NO.: \_\_\_\_\_  
F.A.P. NO.: \_\_\_\_\_  
PARCEL NO.: \_\_\_\_\_  
COUNTY OF: \_\_\_\_\_  
BID LETTING OF: March 30 2011

I, Kelly A. Wilkie, hereby  
declare that I am Vice-President of Douglas N. Higgins, Inc.  
Of Ann Arbor, Michigan

and that I am the person responsible within my firm for the final decision as to the price(s) and amount of this Bid on this State Project.

I further declare that:

1. The prices(s) and amount of this bid have been arrived at independently, without consultation, communication or agreement, for the purpose of restricting competition with any other contractor, bidder or potential bidder.
2. Neither the price(s) nor the amount of this bid have been disclosed to any other firm or person who is a bidder or potential bidder on this project, and will not be so disclosed prior to the bid opening.
3. No attempt has been made or will be made to solicit, cause or induce any other firm or person to refrain from bidding on this project, or to submit a bid higher than the bid of this firm, or any intentionally high or non-competitive bid or other form of complementary bid.
4. The bid of my firm is made in good faith and not pursuant to any agreement or discussion with, or inducement from, any firm or person to submit a complementary bid.
5. My firm has not offered or entered into a subcontract or agreement regarding the purchase of materials or services from any firm or person, or offered, promised or paid cash or anything of value to any firm or person, whether in connection with this or any other project, in consideration for an agreement or promise by any firm or person to refrain from bidding or to submit a complementary bid on this project.
6. My firm has not accepted or been promised any subcontract or agreement regarding the sale of materials or services to any firm or person, and has not been promised or paid cash or anything of value by any firm or person, whether in connection with this or any other project, in consideration for my firm's submitting a complementary bid, or agreeing to do so, on this project.
7. I have made a diligent inquiry of all members, officers, employees, and agents of my firm with responsibilities relating to the preparation, approval or submission of my firm's bid on this project and have been advised by each of them that he or she has not participated in any communication, consultation, discussion, agreement, collusion, act or other conduct inconsistent with any of the statements and representations made in this Declaration.
8. As required by Section 337.165, Florida Statutes, the firm has fully informed the Department of Transportation in writing of all convictions of the firm, its affiliates (as defined in Section 337.165(1)(a), Florida Statutes), and all directors, officers, and employees of the firm and its affiliates for violation of state or federal antitrust laws with respect to a public contract or for violation of any state or federal law involving fraud, bribery, collusion, conspiracy or material misrepresentation with respect to a public contract. This includes disclosure of the names of current employees of the firm or affiliates who were convicted of contract crimes while in the employ of another company.

9. I certify that, except as noted below, neither my firm nor any person associated therewith in the capacity of owner, partner, director, officer, principal, investigator, project director, manager, auditor, and/or position involving the administration of Federal funds:

(a) is presently debarred, suspended, proposed for debarment, declared ineligible, or voluntarily excluded from covered transactions, as defined in 49 CFR §29.110(a), by any Federal department or agency;

(b) has within a three-year period preceding this certification been convicted of or had a civil judgment rendered against him or her for: commission of fraud or a criminal offense in connection with obtaining, attempting to obtain, or performing a Federal, State or local government transaction or public contract; violation of Federal or State antitrust statutes; or commission of embezzlement, theft, forgery, bribery, falsification or destruction of records, making false statements or receiving stolen property;

(c) is presently indicted for or otherwise criminally or civilly charged by a Federal, State or local governmental entity with commission of any of the offenses enumerated in paragraph 9(b) of this certification; and

(d) has within a three-year period preceding this certification had one or more Federal, State or local government public transactions terminated for cause or default..

10. I(We), certify that I(We), shall not knowingly enter into any transaction with any subcontractor, material supplier, or vendor who is debarred, suspended, declared ineligible, or voluntarily excluded from participation in this contract by any Federal Agency unless authorized by the Department.

Where I am unable to declare or certify as to any of the statements contained in the above stated paragraphs numbered (1) through (10), I have provided an explanation in the "Exceptions" portion below or by attached separate sheet.

EXCEPTIONS:

(Any exception listed above will not necessarily result in denial of award, but will be considered in determining bidder responsibility. For any exception noted, indicate to whom it applies, initiating agency and dates of agency action.

Providing false information may result in criminal prosecution and/or administrative sanctions.)

I declare under penalty of perjury that the foregoing is true and correct.

CONTRACTOR: DOUGLAS N. HOGGINS, INC.

BY: Kelly A. Wilkie, Vice-President  
NAME AND TITLE PRINTED

WITNESS: [Signature]

BY: Kelly A. Wilkie  
SIGNATURE

WITNESS: [Signature]

Executed on this 30th day of March, 2011

**FAILURE TO FULLY COMPLETE AND EXECUTE THIS DOCUMENT  
MAY RESULT IN THE BID BEING DECLARED NONRESPONSIVE**

**CITY OF KEY WEST INDEMNIFICATION FORM**

The Contractor shall indemnify and hold harmless the City of Key West, its officers, and employees, from liabilities, damages, losses and costs, including, but not limited to reasonable attorney's fees, to the extent caused by the negligence, recklessness or intentional wrongful misconduct of Contractor and persons employed or utilized by Contractor in the performance of this agreement. Except as specifically provided herein, this agreement does not require Contractor to indemnify the City of Key West, its employees, officers, directors, or agents from any liability, damage, loss, claim, action or proceeding.

These indemnifications shall survive the term of this agreement. In the event that any action or proceeding is brought against the City of Key West by reason of such claim or demand, Contractor shall, upon written notice from the City of Key West, resist and defend such action or proceeding by counsel satisfactory to the City of Key West.

The indemnification provided above shall obligate Contractor to defend at its own expense to and through appellate, supplemental or bankruptcy proceeding, or to provide for such defense, at the City of Key West's option, any and all claims of liability and all suits and actions of every name and description covered above which may be brought against the City of Key West whether performed by Contractor, or persons employed or utilized by Contractor.

The Contractor's obligation under this provision shall not be limited in any way by the agreed upon Contract Price as shown in this agreement, or the Contractor's limit of or lack of sufficient insurance protection.

CONTRACTOR: Douglas N. Higgins, Inc. SEAL:  
3398 Travis Pointe Rd. Suite A  
Ann Arbor, MI 48108  
Address  
Kelly A. Wilkie  
Signature  
Kelly A. Wilkie  
Print Name  
Vice-President  
Title  
DATE: MARCH 30, 2011

For bids to be received on March 30, 2011  
(Letting Date)

Fill in your FDOT Vendor Number  
VF 381807765002

CERTIFICATE

I hereby certify that the amount of any proposal submitted by this bidder for the above letting does not exceed the amount of the Firm's CURRENT CAPACITY (maximum capacity rating less total uncompleted work).

The total uncompleted work as shown on the "Status of Contracts on Hand" report (page 2)

\$ 3,924,115.00

I further certify that the "Status of Contracts on Hand" report (page 2) was prepared as follows:

1. If the letting is before the 25th day of the month, the certificate and report reflect the uncompleted work as of the 15th day of the month, last preceding the month of the letting.
2. If the letting is after the 25th day of the month, the certificate and report reflects the uncompleted work in progress as of the 15th day of the month of the letting.
3. All new contracts (and subcontracts) awarded earlier than five days before the letting date are included in the report and charged against our total rating.

I certify that the information above is correct.

Sworn to and subscribed before me this 30th day  
of March, 20 11  
by Kelly A. Wilkie (name).

Douglas N. Higgins, Inc.  
NAME OF FIRM  
By: Kelly A. Wilkie  
Vice-President  
Title

He/She is personally known to me or has produced  
known  
(type of identification)

R. Suzanne Hawker  
Notary's Signature  
**R. SUZANNE HAWKER**  
Notary Public, Washtenaw County, MI  
My Commission Expires Mar 7, 2017  
Notary's printed name  
Commission expires  
(SEAL)

CURRENT CAPACITY VERIFIED:  
Date: \_\_\_\_\_  
Contracts Administration Office





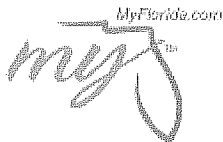

# Contractor Pre-Qualification (CPQ)

Logout DANH@DNHIGGINS.COM



[Update Work Underway](#)  
[Help](#)

## Update Prequalification

3/29/2011 10:19:45 AM EST

- [Vendor](#) [Stakeholders](#) [Affiliates](#) [Work Classes](#) [Financial](#) [Contracts](#) [Manage](#)
- [Attach Financial Statements](#) [Additional Documentation](#) [Submit](#) [Application Summary](#)

**Vendor Number:** F381807765002

**Name:** DOUGLAS N. HIGGINS, INC.

**Application Status:** PENDING  
SUBMITTAL

**Fiscal Year End Date:** 3/31/2010 **Application Due Date:**  
7/31/2010

|                                |                  |   |                   |
|--------------------------------|------------------|---|-------------------|
| <b>Adjusted Current Ratio:</b> | 2                |   |                   |
| <b>Ability Score:</b>          | 82               | <b>Surety Multiplier:</b>               | 3.8               |
| <b>Ability Factor:</b>         | 8                | <b>Calculated Maximum Bid Capacity:</b> | \$ 550,550,000.00 |
| <b>Adjusted Net Worth:</b>     | \$ 34,408,893.70 |   |                   |

| Document                     | Mailed    | Received  | Attached       |
|------------------------------|-----------|-----------|----------------|
| Audited Financial Statements | 7/20/2010 | 7/26/2010 | N/A            |
| Affidavit                    | 7/26/2010 | 7/26/2010 |                |
| Equipment                    | 7/20/2010 | 7/26/2010 |                |
| Surety Letter                |           |           |                |
| Letters of Recommendation    |           |           |                |
| Audited Financial Statements | N/A       | N/A       | FINANCIALS.PDF |
| Additional Document          | N/A       | N/A       |                |

Save Cancel

| Event                           | Date      | Comment  |
|---------------------------------|-----------|--|
| APPLICATION CREATED             | 7/19/2010 |  |
| APPLICATION SUBMITTED           | 7/26/2010 | NO COMMENT SUBMITTED   |
| APPLICATION ACCEPTED            | 7/27/2010 |  |
| APPLICATION APPROVED            | 8/11/2010 | IF APPLICABLE, A SIGNED CERTIFICATE OF QUALIFICATION IS BEING MAILED TO YOUR HOME OFFICE. YOU CAN ACCESS YOUR FIRM'S MAXIMUM BID CAPACITY AND APPROVED WORK CLASSES ON THE CAPACITY AND WORK CLASS TABS. |
| PREQUALIFICATION UPDATE CREATED | 3/29/2011 |  |



**FLORIDA DEPARTMENT OF TRANSPORTATION**  
 Report Technical Problems to the Service Desk @ 1-866-955-4357 or email: [Service Desk](#)  
 Send Prequalification Questions or Comments to [Contracts Administration Office](#)  
[Internet Privacy Policy, Disclaimers & Credits](#)



**ATTACHMENT I: NON-COLLUSION DECLARATION AND COMPLIANCE WITH 49 CFR §29**

FORM 575-060-13  
RIGHT OF WAY - 05/01

**NON-COLLUSION DECLARATION AND  
COMPLIANCE WITH 49 CFR §29.**  
STATE OF FLORIDA DEPARTMENT OF TRANSPORTATION

ITEM/SEGMENT NO.: \_\_\_\_\_  
F.A.P. NO.: \_\_\_\_\_  
PARCEL NO.: \_\_\_\_\_  
COUNTY OF: \_\_\_\_\_  
BID LETTING OF: March 30, 2011

I, Kelly A. Wilkie, hereby  
(NAME)  
declare that I am Vice-President of Douglas N. Higgins, Inc.  
(TITLE) (FIRM)  
Of Ann Arbor, Michigan  
(CITY AND STATE)

and that I am the person responsible within my firm for the final decision as to the price(s) and amount of this Bid on this State Project.

I further declare that:

1. The prices(s) and amount of this bid have been arrived at independently, without consultation, communication or agreement, for the purpose of restricting competition with any other contractor, bidder or potential bidder.
2. Neither the price(s) nor the amount of this bid have been disclosed to any other firm or person who is a bidder or potential bidder on this project, and will not be so disclosed prior to the bid opening.
3. No attempt has been made or will be made to solicit, cause or induce any other firm or person to refrain from bidding on this project, or to submit a bid higher than the bid of this firm, or any intentionally high or non-competitive bid or other form of complementary bid.
4. The bid of my firm is made in good faith and not pursuant to any agreement or discussion with, or inducement from, any firm or person to submit a complementary bid.
5. My firm has not offered or entered into a subcontract or agreement regarding the purchase of materials or services from any firm or person, or offered, promised or paid cash or anything of value to any firm or person, whether in connection with this or any other project, in consideration for an agreement or promise by any firm or person to refrain from bidding or to submit a complementary bid on this project.
6. My firm has not accepted or been promised any subcontract or agreement regarding the sale of materials or services to any firm or person, and has not been promised or paid cash or anything of value by any firm or person, whether in connection with this or any other project, in consideration for my firm's submitting a complementary bid, or agreeing to do so, on this project.

7. I have made a diligent inquiry of all members, officers, employees, and agents of my firm with responsibilities relating to the preparation, approval or submission of my firm's bid on this project and have been advised by each of them that he or she has not participated in any communication, consultation, discussion, agreement, collusion, act or other conduct inconsistent with any of the statements and representations made in this Declaration.

8. As required by Section 337.165, Florida Statutes, the firm has fully informed the Department of Transportation in writing of all convictions of the firm, its affiliates (as defined in Section 337.165(1)(a), Florida Statutes), and all directors, officers, and employees of the firm and its affiliates for violation of state or federal antitrust laws with respect to a public contract or for violation of any state or federal law involving fraud, bribery, collusion, conspiracy or material misrepresentation with respect to a public contract. This includes disclosure of the names of current employees of the firm or affiliates who were convicted of contract crimes while in the employ of another company.

9. I certify that, except as noted below, neither my firm nor any person associated therewith in the capacity of owner, partner, director, officer, principal, investigator, project director, manager, auditor, and/or position involving the administration of Federal funds:

(a) is presently debarred, suspended, proposed for debarment, declared ineligible, or voluntarily excluded from covered transactions, as defined in 49 CFR §29.110(a), by any Federal department or agency;

(b) has within a three-year period preceding this certification been convicted of or had a civil judgment rendered against him or her for: commission of fraud or a criminal offense in connection with obtaining, attempting to obtain, or performing a Federal, State or local government transaction or public contract; violation of Federal or State antitrust statutes; or commission of embezzlement, theft, forgery, bribery, falsification or destruction of records, making false statements or receiving stolen property;

(c) is presently indicted for or otherwise criminally or civilly charged by a Federal, State or local governmental entity with commission of any of the offenses enumerated in paragraph 9(b) of this certification; and

(d) has within a three-year period preceding this certification had one or more Federal, State or local government public transactions terminated for cause or default..

10. I(We), certify that I(We), shall not knowingly enter into any transaction with any subcontractor, material supplier, or vendor who is debarred, suspended, declared ineligible, or voluntarily excluded from participation in this contract by any Federal Agency unless authorized by the Department.

Where I am unable to declare or certify as to any of the statements contained in the above stated paragraphs numbered (1) through (10), I have provided an explanation in the "Exceptions" portion below or by attached separate sheet.

EXCEPTIONS:

(Any exception listed above will not necessarily result in denial of award, but will be considered in determining bidder responsibility. For any exception noted, indicate to whom it applies, initiating agency and dates of agency action.

Providing false information may result in criminal prosecution and/or administrative sanctions.)

I declare under penalty of perjury that the foregoing is true and correct.

CONTRACTOR: DOUGLAS N. HIGGINS, INC.

BY: Kelly A. Wilkie  
NAME AND TITLE PRINTED

WITNESS: Kelly A. Wilkie

BY: Kelly A. Wilkie  
SIGNATURE

WITNESS: Sam H. Smith

Executed on this 30th day of March, 2011

**FAILURE TO FULLY COMPLETE AND EXECUTE THIS DOCUMENT  
MAY RESULT IN THE BID BEING DECLARED NONRESPONSIVE**

---

## BIDDER'S CHECKLIST

(Note: The purpose of this checklist is to serve as a reminder of major items to be addressed in submitting a bid and is not intended to be all inclusive. It does not alleviate the Bidder from the responsibility of becoming familiar with all aspects of the Contract Documents and Proper completion and submission of his bid.)

1. All Contract Documents thoroughly read and understood
2. All blank spaces in Proposal filled in, using black ink.
3. Total and unit Prices added correctly.
4. Addenda acknowledged.
5. Subcontractors are named as indicated in the Proposal.
6. Experience record included.
7. Proposal signed by authorized officer.
8. Bid Bond completed and executed, including power-of-attorney dated the same date as Bid Bond.
9. Bidder familiar with federal, state, and local laws, ordinances, rules and regulations affecting performance of the work.
10. Bidder shall demonstrate possession of required licenses and certificates to bid the job.
11. Proposal submitted intact with the volume entitled "Proposal" and Contract Forms, submit 1 original & 2 copies and 2 CD-Roms or flash drives each with one PDF file of the full Proposal.
12. Bid Documents submitted in sealed envelope and addressed and labeled in conformance with the instructions in the Invitation to Bid.
13. Bidder submitted FDOT Pre-certification paperwork
14. Bidder signed and submitted the suspension and debarment certification
15. Bidder signed and submitted Non-Collusion Declaration and Compliance with 49 CFR §29 form
16. Bidder signed and submitted the Prohibited Interests Form
17. Remainder of required forms.

# CITY OF KEY WEST, FLORIDA

## Business Tax Receipt

This Document is a business tax receipt  
Holder must meet all City zoning and use provisions.  
P.O. Box 1409, Key West, Florida 33040 (305) 809-3955

Business Name DOUGLAS N. HIGGINS (CGC) CtlNbr:0018021  
Location Addr 3390 TRAVIS POINTE STE A RD  
Lic NBR/Class 11-00022114 CONTRACTOR - CERT GENERAL CONTRACTOR  
Issue Date: July 13, 2010 Expiration Date: September 30, 2011  
License Fee \$309.75  
Add. Charges \$0.00  
Penalty \$0.00  
Total \$309.75  
Comments:

Oper: ANGLE Type: GC Drawer: 1  
Date: 7/14/10 51 Receipt no: 90659  
2011 2214  
OR LIC OCCUPATIO 1 \$309.75  
Trans number: 2507794  
CK CHECK 13743 \$309.75  
Trans date: 7/14/10 Time: 11:20:21

This document must be prominently displayed.

DOUGLAS N. HIGGINS, INC

DOUGLAS N. HIGGINS (CGC)  
3390 TRAVIS POINTE STE A RD  
ANN ARBOR MI 48108

# CITY OF KEY WEST, FLORIDA

## Business Tax Receipt

This Document is a business tax receipt  
Holder must meet all City zoning and use provisions.  
P.O. Box 1409, Key West, Florida 33040 (305) 809-3955

Business Name DOUGLAS N HIGGINS INC. CtlNbr:0004241  
Location Addr 3390 TRAVIS POINTE STE A RD  
Lic NBR/Class 11-00004242 CONTRACTOR - CERT UNDERGROUND UTILITY  
Issue Date: July 14, 2010 Expiration Date: September 30, 2011  
License Fee \$309.75  
Add. Charges \$0.00  
Penalty \$0.00  
Total \$309.75  
Comments:

This document must be prominently displayed.

DOUGLAS N. HIGGINS, INC

DOUGLAS N HIGGINS INC.  
3390 TRAVIS POINTE RD STE A  
ANN ARBOR MI 48108

Oper: CWLKER Type: GC Drawer: 1  
Date: 7/15/10 51 Receipt no: 90571  
2011 4242  
OR LIC OCCUPATIO 1 \$309.75  
Trans number: 2508461  
CK CHECK 13742 \$309.75  
Trans date: 7/15/10 Time: 11:25:41



**2010 / 2011  
MONROE COUNTY BUSINESS TAX RECEIPT  
EXPIRES SEPTEMBER 30, 2011**

RECEIPT# 30140-62369

Business Name: DOUGLAS N HIGGINS INC

Owner Name: DOUGLAS N HIGGINS, JAMES SWEET QUALIFIER

Mailing Address: 3390 TRAVIS POINTE RD  
Ste A  
ANN ARBOR, MI 48108

Business Location: MO CTY  
KEY WEST, FL 33040

Business Phone: 305-294-3355  
Business Type: CONTRACTORS  
(UNDERGROUND UTILITY)

Rooms      Seats      Employees      Machines      Stalls

5

STATE LICENSE: CUC057447 EXP 8-31-8

Number of Machines :      For Vending Business Only      Vending Type : M

| Tax Amount | Transfer Fee | Sub-Total | Penalty | Prior Years | Collection Cost | Total Paid |
|------------|--------------|-----------|---------|-------------|-----------------|------------|
| \$20.00    |              | \$20.00   |         | \$0.00      |                 | \$20.00    |

PAID-118-09-00004891      07/13/2010      20.00

**THIS RECEIPT MUST BE POSTED CONSPICUOUSLY IN YOUR PLACE OF BUSINESS**

THIS BECOMES A TAX RECEIPT  
WHEN VALIDATED

**Danise D. Henriquez, CFC, Tax Collector**  
PO Box 1129, Key West, FL 33041

THIS IS ONLY A TAX. YOU MUST  
MEET ALL COUNTY AND/OR  
MUNICIPALITY PLANNING AND  
ZONING REQUIREMENTS.



STATE OF FLORIDA

DEPARTMENT OF BUSINESS AND PROFESSIONAL REGULATION

CONSTRUCTION INDUSTRY LICENSING BOARD
1940 NORTH MONROE STREET
TALLAHASSEE FL 32399-0783

(850) 487-1395

HIGGINS, DANIEL NORMAN
DOUGLAS N HIGGINS INC
3390 TRAVIS POINTE ROAD
SUITE A
ANN ARBOR MI 48108

Congratulations! With this license you become one of the nearly one million Floridians licensed by the Department of Business and Professional Regulation.

Every day we work to improve the way we do business in order to serve you better. For information about our services, please log onto www.myfloridalicense.com.

Our mission at the Department is: License Efficiently, Regulate Fairly. We constantly strive to serve you better so that you can serve your customers.

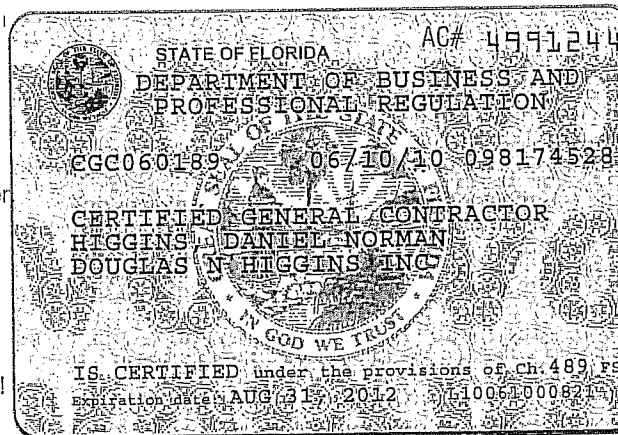

DETACH HERE

AC# 4991244 STATE OF FLORIDA DEPARTMENT OF BUSINESS AND PROFESSIONAL REGULATION CONSTRUCTION INDUSTRY LICENSING BOARD SEQ# D10061000821
DATE BATCH NUMBER LICENSE NBR
06/10/2010 098174528 CCG060189
The GENERAL CONTRACTOR Named below IS CERTIFIED Under the provisions of Chapter 489 FS Expiration date: AUG 31, 2012
HIGGINS, DANIEL NORMAN DOUGLAS N HIGGINS INC 3390 TRAVIS POINTE ROAD SUITE A ANN ARBOR MI 48108
CHARLIE CRIST CHARLIE LIEM



# Florida Department of Transportation

CHARLIE CRIST  
GOVERNOR

605 Suwannee Street  
Tallahassee, FL 32399-0450

STEPHANIE C. KOPELOUSOS  
SECRETARY

August 13, 2010

DOUGLAS N. HIGGINS, INC.  
3390 TRAVIS POINTE ROAD  
ANN ARBOR MI 48108

RE: CERTIFICATE OF QUALIFICATION

Dear Sir/Madam:

The Department of Transportation has qualified your company for the amount and the type of work indicated below. Unless your company is notified otherwise, this rating will expire 9/30/2011. However, the new application is due 7/31/2011.

In accordance with S.337.14 (1) F.S. your next application must be filed within (4) months of the ending date of the applicant's audited annual financial statements and, if applicable, the audited interim financial statements. Section 337.14 (4) F.S. provides that your certificate will be valid for 18 months after your financial statement date. This gives a two month period to allow you to bid on jobs as we process your new application for qualification. To remain qualified with the Department, a new application must be submitted subsequent to any significant change in the financial position or the structure of your firm as described in Section 14-22.005(3), Florida Administrative Code.

MAXIMUM CAPACITY RATING: \$550,550,000.00

FDOT APPROVED WORK CLASSES:  
DRAINAGE, GRADING

FDOT APPROVED SPECIALITY CLASSES OF WORK:  
UNDERGROUND UTILITIES, WATER MAINS, SANITARY LINES, FORCE MAINS, SEWER LINES, PUMP STATIONS.

You may apply, in writing, for a Revised Certificate of Qualification at any time prior to the expiration date of this certificate according to Section 14-22.0041(3), Florida Administrative Code. Please be advised if certification in additional classes of work is desired, documentation is needed to show that your company has done such work with your own forces and equipment or that experience was gained with another contractor and that you have the necessary equipment for each additional class of work requested.

Sincerely,

Juanita Moore, Manager  
Contracts Administration Office

JM:cj



SURETY CAPACITY ELIGIBILITY DETERMINATION\*

FIRM NAME  
Douglas N. Higgins, Inc.

DATE  
8/10/10

CURRENT RATIO FACTOR

ABILITY SCORE

2.00  
Less than 1.00 - Not Eligible for Increased Bidding Capacity  
1.00 or Greater - Eligible

82  
Less than 80 - Not Eligible for Increased Bidding Capacity.  
80 - 90 - See Table for Surety Multiplier.  
Greater than 90 - Amount Shown on Surety Letter.

TABLE

SURETY CAPACITY FORMULA

ABILITY SCORE SURETY MULTIPLIER (S.M.) (SURETY MULTIPLIER X MAXIMUM CAPACITY RATING X CONSTRUCTION REVENUES/TOTAL REVENUES) (MCR)

(A.S.) (S.M.) (S.M.) X X \$550,550,000.00 (CRV/TRV)

80 3.0 3.8  
81 3.4  
82 3.8  
83 4.2  
84 4.6  
85 5.0  
86 5.6  
87 6.2  
88 6.8  
89 7.4  
90 8.0

EQUALS SURETY CAPACITY ELIGIBILITY  
\$2,092,090,000.00

>90 No limit to eligibility for surety backed Bid Capacity

\* Please see Rule 14-22 for information regarding surety calculations.

---

---

**STATEMENT OF NO PROPOSAL**

Note: If you do not intend to submit a Proposal, please return this form ONLY.

TO: "College Road Enhancements, Overseas Highway to Kokenzie Road" GN 0711  
Office of the City Clerk  
City of Key West P.O. Box 1409  
Key West, FL. 33041-1409

We, the undersigned, have declined to submit a Proposal on the above-noted Request for Proposal for the following reasons:

- Insufficient time to respond to the Request for Proposal
- Do not offer this Product
- Our schedule will not permit us to perform
- Unable to meet specifications
- Specifications unclear (Please explain below)
- Remove us from the City of Key West's, "Bidder's Mailing List"
- Other (Please specify below)

REMARKS: \_\_\_\_\_  
\_\_\_\_\_  
\_\_\_\_\_

We understand that if a "no Proposal" statement is not returned, our name may be removed from the bidder's list of the City of Key West.

COMPANY NAME: \_\_\_\_\_

SIGNATURE: \_\_\_\_\_

DATE: \_\_\_\_\_ TELEPHONE: \_\_\_\_\_