

# CONTRACT DOCUMENTS FOR:

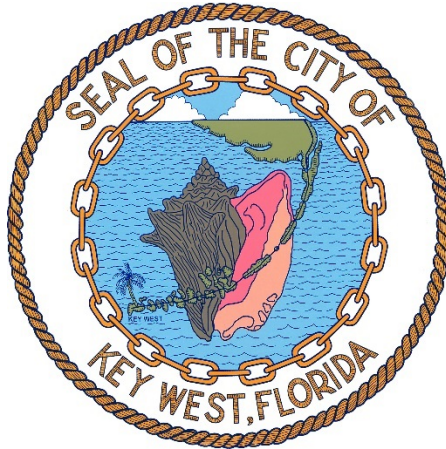

---

ITB # 22-002

C.B. HARVEY REST BEACH SHELTERS

OCTOBER 2021

---

MAYOR: TERI JOHNSTON

COMMISSIONERS:

GREGORY DAVILA

BILLY WARDLOW

JIMMY WEEKLEY

CLAYTON LOPEZ

SAM KAUFMAN

MARY LOU HOOVER

PREPARED BY:  
City of Key West  
Engineering Services

CITY OF KEY WEST

KEY WEST, FLORIDA

CONTRACT DOCUMENTS

For

C.B. HARVEY REST BEACH SHELTERS

\*\*\*\*

CONSISTING OF:  
BID REQUIREMENTS  
CONTRACT FORMS  
CONDITIONS OF THE CONTRACT  
GENERAL REQUIREMENTS  
DRAWINGS

\*\*\*\*\*

KEY WEST, FLORIDA

OCTOBER 2021

Table of Contents

Page No.

**PART 1 - BIDDING REQUIREMENTS**

INVITATION TO BID ..... 1  
INSTRUCTIONS TO BIDDER ..... 3  
PROPOSAL FORM..... 9  
FLORIDA BID BOND ..... 17  
VENDOR CERTIFICATION REGARDING SCRUTINIZED COMPANIES  
LISTS ..... 19  
ANTI – KICKBACK AFFIDAVIT ..... 20  
FLORIDA STATUTES, ON PUBLIC ENTITY CRIMES ..... 21  
INDEMNIFICATION FORM ..... 24  
LOCAL VENDORS FORM..... 25  
DOMESTIC PARTNERSHIP AFFIDAVIT ..... 26  
CONE OF SILENCE AFFIDAVIT ..... 27  
NON-COLLUSION AFFIDAVIT.....31  
BIDDER'S CHECKLIST..... 32

**PART 2 - CONTRACT**

CONTRACT ..... 34

**PART 3 - CONDITIONS OF THE CONTRACT**

GENERAL CONDITIONS ..... 37  
SUPPLEMENTARY CONDITIONS ..... 61

**PART 4 - GENERAL REQUIREMENTS & SCOPE OF WORK**

SECTION 01001 – GENERAL REQUIREMENTS.....68  
SECTION 01010 – SCOPE OF WORK..... 74

**PART 5 - DRAWINGS**

REST BEACH SHELTERS.....76

---

---

**PART 1**

**BIDDING REQUIREMENTS**

---

---



## INVITATION TO BID

Sealed bids for the City of Key West ITB #

C.B. HARVEY REST BEACH SHELTERS, addressed to the City of Key West, will be received at the Office of the City Clerk, 1300 White Street., Key West Florida, 33040 until 3:00 p.m. on November 10, 2021 and then will be publicly opened and read. Any bids received after the time and date specified will not be considered.

**Please submit one (1) original, and two (2) flash drives each with one single PDF file of the sections entitled “Bidding Requirements” and “Contract Forms”. Bid package is to be enclosed in a sealed envelope, clearly marked on the outside “ITB # 22-002 C.B. HARVEY REST BEACH SHELTERS” addressed and delivered to the City Clerk at the address noted above.**

The proposed project consists of providing all materials, equipment and labor necessary to construct shelters at C.B. Harvey Rest Beach; including the removal of existing structure and construction of three new timber structures and three 10’ x 10’ concrete slabs.

Drawings and Specifications may be obtained from Demand Star by Onvia or City of Key West. Please contact Demand Star at [www.demandstar.com](http://www.demandstar.com) or call 1-800-711-1712 or [www.cityofkeywest-fl.gov](http://www.cityofkeywest-fl.gov)

**EACH BID MUST BE SUBMITTED ON THE PRESCRIBED FORM AND ACCOMPANIED BY BID SECURITY AS PRESCRIBED IN THE INSTRUCTIONS TO BIDDERS, PAYABLE TO THE CITY OF KEY WEST, FLORIDA, IN AN AMOUNT NOT LESS THAN FIVE (5) PERCENT OF THE AMOUNT BID.**

**THE BIDDER MUST BE A LICENSED CONTRACTOR BY THE STATE OF FLORIDA AND SUBMIT PROOF OF SUCH WITH THE BID.**

The successful Bidder shall furnish documentation showing that he is in compliance with the licensing requirements of the State and the provisions of Chapter 66 Section 87 of the Code of Ordinances of the City of Key West; within 10 days following the Notice of Award and must demonstrate that he holds at a minimum, the following licenses & certificates;

- A. City of Key West Business Tax License Receipt
- B. A valid Certificate of Competency issued by the Chief Building Official of Key West, Florida.

All bid bonds, insurance contracts, and certificates of insurance shall be either executed by or countersigned by a licensed resident agent of the Surety or Insurance Company having his place of business in the State of Florida, and in all ways complying with the insurance laws of the State of Florida. Further, the said Surety or Insurance Company shall be duly licensed and qualified to do business in the State of Florida.

Before a Contract will be awarded for the work contemplated herein, the CITY will conduct such investigation as is necessary to determine the performance record and ability of the apparent low Bidder to perform the size and type of work specified under this Contract. Upon request, the Bidder

shall submit such information as deemed necessary by the CITY to evaluate the Bidder's qualifications.

**Any request for information concerning this project must be made in writing, per City of Key West Ordinance Section 2-773, Code of Silence, to Ian McDowell, Assistant Engineer, at [cimcdowell@cityofkeywest-fl.gov](mailto:cimcdowell@cityofkeywest-fl.gov).**

As stated above at the time of the bid submittal the Bidder must provide satisfactory documentation of State Licenses. The Bidder shall furnish documentation showing that he is in compliance with the licensing requirements of County, and City licenses as would be required within ten days of the award. The successful Bidder must also be able to satisfy the CITY Attorney as to such insurance coverage and legal requirements as may be demanded by the Bid in question. The CITY may reject bids for any and/or all of the following reasons: (1) for budgetary reasons, (2) if the bidder misstates or conceals a material fact in its bid, (3) if the bid does not strictly conform to the law or is non-responsive to the bid requirements, (4) if the bid is conditional, or (5) if a change of circumstances occurs making the purpose of the bid unnecessary to the CITY. The CITY may also waive any minor formalities or irregularities in any bid, (6) if such rejection is in the best interest of the CITY.

## INSTRUCTIONS TO BIDDERS

### 1. CONTRACT DOCUMENTS

#### A. FORMAT

The Contract Documents are divided into parts, divisions, and sections for convenient organization and reference. Generally, there has been no attempt to divide the sections into work performed by the various building trades, work by separate subcontractors, or work required for separate facilities in the project.

#### B. DOCUMENT INTERPRETATION

The separate sections contained within these Contract Documents are intended to be mutually cooperative and to provide all details reasonably required for the execution of the proposed work.

Should there be any doubt as to the meaning or intent of said Contract Documents, the Bidder should request of the ENGINEER, in writing (at least ten (10) calendar days prior to bid opening) an interpretation thereof. Any interpretation or change in said Contract Documents will be made only in writing in the form of Addenda to the documents which will be available to all registered holders of Contract Documents via Demand star. Bidders shall submit with their Bids, or indicate receipt of, all Addenda. The CITY will not be responsible for any other explanation or interpretations of said Documents.

### 2. GENERAL DESCRIPTION OF THE PROJECT

A general description of the work to be done is contained in the Invitation to Bid. The scope is specified in applicable parts of these Contract Documents.

### 3. QUALIFICATION OF CONTRACTORS

The prospective Bidders must meet the statutorily prescribed requirements before award of Contract by the CITY. Bidders must hold or obtain all licenses and/or certificates as required by the State and Local Statutes to bid and perform the work specified herein.

### 4. BIDDER'S UNDERSTANDING

Each Bidder must inform themselves of the conditions relating to the execution of the work, and it is assumed that he will inspect the site and make themselves thoroughly familiar with all the Contract Documents. Failure to do so will not relieve the successful Bidder of his obligation to enter a Contract and complete the contemplated work in strict accordance with the Contract Documents. It shall be the Bidder's obligation to verify for themselves and to his complete satisfaction all information concerning site and subsurface conditions.

The CITY will make available to prospective Bidders upon request and at the office of the ENGINEER, prior to bid opening, any information that he may have as to subsurface conditions

and surface topography at the worksite.

Each Bidder shall inform themselves of, and the Bidder awarded a Contract shall comply with, federal, state, and local laws, statutes, and ordinances relative to the execution of the work. This requirement includes, but is not limited to, applicable regulations concerning minimum wage rates, nondiscrimination in the employment of labor, protection of public and employee safety and health, environmental protection, the protection of natural resources, fire protection, burning and non-burning requirements, permits, fees, and similar subjects.

5. TYPE OF BID

A. LUMP SUM

The BID for the work is to be submitted on a lump sum basis. Lump sum prices shall be submitted for all items of work set forth in the bid. All items required to complete the work specified but not included in the bid shall be considered incidental to those set forth in the bid.

**The Bidder shall submit a Schedule of Values with the BID. It shall be broken down by trade and type of work and include the cost of all LABOR & MATERIALS for use as a basis for payment.**

6. PREPARATION OF BIDS

A. GENERAL

All blank spaces in the BID form must be filled in, as required, preferably in BLACK ink. All price information shall be shown in both words and figures where required. No changes shall be made in the phraseology of the forms. Written amounts shall govern in case of discrepancy between the amounts stated in writing and the amounts stated in figures. In case of discrepancy between unit prices and extended totals, unit prices shall prevail.

Any BID shall be deemed informal which contains omissions, erasures, alterations, or additions of any kind, or prices uncalled for, or in which any of the prices are obviously unbalanced, or which in any manner shall fail to conform to the conditions of the published Invitation to Bid.

Only one BID from any individual, firm, partnership, or corporation, under the same or different names, will be considered. Should it appear to the CITY that any Bidder is interested in more than one Bid for work contemplated; all Bids in which such Bidder is interested will be rejected.

B. SIGNATURE

The Bidder shall sign his BID in the blank space provided therefore. If Bidder is a corporation, the legal name of the corporation shall be set forth above, together with the

signature of the officer or officers authorized to sign Contracts on behalf of the corporation. If Bidder is a partnership, the true name of the firm shall be set forth above, together with the signature of the partner or partners authorized to sign Contracts in behalf of the partnership. If signature is by an agent, other than an officer of a corporation or a member of a partnership, a notarized power-of-attorney must be on file with the CITY prior to opening of Bids or submitted with the Bid, otherwise the Bid will be regarded as not properly authorized.

C. SPECIAL BIDDING REQUIREMENTS

The Bidder's attention is brought to the hiring practices and licenses and permits of the City of Key West. These are defined in the addition to Article 39, ORDINANCES, PERMITS, AND LICENSES, as set forth in the Supplementary Conditions.

The Bidder shall submit with his Bid his experience record showing his experience and expertise in timber construction and related work. Such experience record shall provide at least five current or recent projects (within the past 5 years) of similar work, within the State Florida and preferably Monroe County. For each project the following information shall be provided:

1. Description and location of work.
2. Contract amount.
3. Dates work was performed.
4. Owner.
5. Name of Owner's contact person and phone number.
6. ENGINEER.
7. Name of ENGINEER's contact person and phone number.

The bidder shall submit with his bid a list of items to be performed by his own labor and that performed by subcontractors or others.

D. ATTACHMENTS

Bidder shall complete and submit the following forms with his bid:

Anti-Kickback Affidavit  
Public Entity Crimes Form  
Indemnification Form  
City of Key West Business License Tax Receipt  
Local Vendors Form (if applicable)  
Domestic Partnership Affidavit  
Cone of Silence Affidavit  
Non-Collusion Affidavit  
Bidders' Checklist

E. PUBLIC ENTITY CRIMES FORM

Pursuant to the requirements of Chapter 287.133, Laws of Florida, pertaining to the sworn statement on Public Entity Crimes and the Convicted Vendor List, all Bidders shall submit a signed and notarized statement with their Bid on the form provided herein.

7. STATE AND LOCAL SALES AND USE TAXES

Unless the Supplementary Conditions contains a statement that the CITY is exempt from state sales tax on materials incorporated into the work due to the qualification of the work under this Contract, the Contractor, as required by the laws and statutes of the state and its political subdivisions, shall pay all state and local sales and use taxes. Prices quoted in the Bid shall include all nonexempt sales and use taxes, unless provision is made in the Bid form to separately itemize the tax.

8. SUBMISSION OF BIDS

All BIDS must be submitted not later than the time prescribed, at the place, and in the manner set forth in the Invitation to Bid. BIDS must be made on the BID forms provided herewith, **submit one (1) ORIGINAL and two (2) FLASH DRIVES each containing a single PDF file of the entire bid package.**

Each BID must be submitted in a sealed envelope, so marked as to indicate the Bidder's name and its contents (project name and number) without being opened and addressed in conformance with the instructions in the Invitation to Bid.

9. MODIFICATION OR WITHDRAWAL OF BIDS

Prior to the time and date designated for receipt of BIDS, any BID submitted may be withdrawn by notice to the party receiving BIDS at the place designated for receipt of BIDS. Such notice shall be in writing over the signature of the Bidder or by telegram. If by telegram, written confirmation over the signature of the Bidder shall be mailed and postmarked on or before the date and time set for receipt of BID. No BID may be withdrawn after the time scheduled for opening of BIDS, unless the time specified in paragraph AWARD OF CONTRACT of these Instructions to Bidders shall have elapsed.

10. BID SECURITY

BIDS must be accompanied by cash, a certified check, or cashier's check drawn on a bank in good standing, or a bid bond issued by a Surety authorized to issue such bonds in the state where the work is located, in the amount of five (5) percent of the total amount of the Bid submitted. This bid security shall be given as a guarantee that the Bidder will not withdraw his BID for a period of ninety (90) days after bid opening.

The Attorney-in-Fact who executes this bond in behalf of the Surety must attach a notarized copy of his power-of-attorney as evidence of his authority to bind the Surety on the date of execution of the bond. Where State Statute requires, certification by a resident agent shall also be provided.

If the Bidder elects to furnish a Bid Bond, he shall use the Bid Bond form bound herewith, or one conforming substantially thereto in form and content.

11. RETURN OF BID SECURITY

Within 15 days after the award of the Contract, the CITY will return the bid securities to all Bidders whose BIDS are not to be further considered in awarding the Contract. Retained bid securities will be held until the Contract has been finally executed, after which all bid securities, other than Bidders' bonds and any guarantees, which have been forfeited, will be returned to the respective Bidders whose Bids they accompanied.

12. AWARD OF CONTRACT

Within ninety (90) calendar days after the opening of Bids, the CITY will accept one of the Bids or will act in accordance with the following paragraphs. The acceptance of the Bid will be by written notice of award, mailed to the office designated in the Bid, or delivered to the Bidder's representative. In the event of failure of the lowest responsive, responsible Bidder to sign the Contract, provide additional documents, insurance certificate(s) and evidence of holding required licenses and certificates, the Owner may award the Contract to the next lowest responsive, responsible Bidder. Such award, if made, will be made within one hundred & twenty (120) days after the opening of Bids.

The CITY reserves the right to accept or reject any or all Bids, and to waive any informalities and irregularities in said Bids.

13. BASIS OF AWARD

The award will be made by the Owner on the basis of the BID from the lowest, responsive, responsible BIDDER which, in the Owner's sole and absolute judgment will best serve the interest of the Owner.

14. EXECUTION OF CONTRACT

The successful Bidder shall, within ten (10) working days after receiving Notice of Award, sign and deliver to the CITY an original Contract and two (2) copies in the form hereto attached, together with the insurance certificate as required in the Contract Documents and evidence of holding required licenses and certificates. Within 10 working days after receiving the signed Contract from the successful Bidder, the City's authorized agent will sign the Contract. Signature by both parties constitutes execution of the Contract.

16. FAILURE TO EXECUTE CONTRACT AND FURNISH BID BOND

The Bidder who has a Contract awarded to them and who fails to promptly and properly execute the Contract shall forfeit the bid security that accompanied his bid, and the bid security shall be retained as liquidated damages by the CITY, and it is agreed that this said sum is a fair estimate of the amount of damages the CITY will sustain in case the Bidder fails to enter into a Contract. Bid

security deposited in the form of cash, a certified check, or cashier's check shall be subject to the same requirement as a Bid Bond.

17. TIME OF COMPLETION

The time of completion of the work to be performed under this Contract is the essence of the Contract. Delays and extensions of time may be allowed in accordance with the provisions stated in the General Conditions.

When the Contractor receives a Notice to Proceed, he shall commence work as soon as possible and shall complete all work within the number of calendar days stipulated in this Bid.

The term of this contract will be **90** calendar days.



NOTE TO BIDDER: Use preferably BLACK ink for completing this BID form.

### PROPOSAL FORM

To: The City of Key West  
Address: 1300 White Street, Key West, Florida 33040  
Project Title: C.B. HARVEY REST BEACH SHELTERS  
ITB 22-002

Bidder's contact person for additional information on this BID:

Company Name: Barracuda Builders of Key West, Inc.  
Contact Name & Telephone #: Bryan Wofscy - 305 396-7752  
Email Address: info @ barracudabuilders.com

### BIDDER'S DECLARATION AND UNDERSTANDING

The undersigned, hereinafter called the Bidder, declares that the only persons or parties interested in this Bid are those named herein, that this Bid is, in all respects, fair and without fraud, that it is made without collusion with any official of the Owner, and that the Bid is made without any connection or collusion with any person submitting another Bid on this Contract.

The Bidder further declares that he has carefully examined the Contract Documents for the construction of the project, that he has personally inspected the site, that he has satisfied as to the quantities involved, including materials and equipment, and conditions of work involved, including the fact that the description of the quantities of work and materials, as included herein, is brief and is intended only to indicate the general nature of the work and to identify the said quantities with the detailed requirements of the Contract Documents, and that this Bid is made according to the provisions and under the terms of the Contract Documents, which Documents are hereby made a part of this Bid.

### CONTRACT EXECUTION

The Bidder agrees that if this Bid is accepted, he will, within 10 days, not including Sundays and legal holidays, after Notice of Award, sign the Contract in the form annexed hereto, and will at that time, deliver to the Owner evidence of holding required licenses and certificates, and will, to the extent of his Bid, furnish all machinery, tools, apparatus, and other means of construction and do the work and furnish all the materials necessary to complete all work as specified or indicated in the Contract Documents.



**PROPOSAL FORM**

**Bonds**

**LUMP SUM BASE BID:**

(Includes all permitting, fixtures, equipment, material & labor)

LUMP SUM \$ 108,075.00

One Hundred Eight Thousand Seventy Five Dollars & Zero Cents  
(amount written in words)

Payment for materials & equipment authorized by the Owner in a written Change Order but not listed in the Schedule of Values will be provided at suppliers' invoice plus 15 %.

**The Bidder shall submit a Schedule of Values with the Proposal ID. It shall be broken down by trade and type of work and include the cost of all LABOR & MATERIALS for use as a basis for payment.**

**ADDITIVE ALTERNATE # 1**

Renovation and repair of C.B. Harvey Rest Beach sign, including necessary repairs to roofing and timber structure.

\$ 4,830.00 Total

**SCHEDULE OF VALUES**

C.B. Harvey Rest Beach Shelters (ITB 22-002)

Barracuda Builders of Key West, Inc.

11/10/2021

<b>Description of Work</b>	<b>Value</b>
General Conditions:	\$13,595.00
Demolition:	\$7,985.00
Concrete Foundation:	\$31,150.00
Timber Framing:	\$34,500.00
T&G/Roof Sheathing:	\$15,620.00
5V Crimp Metal Roof:	\$5,225.00
 TOTAL:	 \$108,075.00
  Add Alternate #1:	  \$4,830.00

List items to be performed by CONTRACTOR's own forces and the estimated total cost of these items. (Use additional sheets if necessary.)

<u>Concrete Foundation :</u>	<u>\$ 31,150.<sup>00</sup></u>
<u>Timber framing:</u>	<u>\$ 34,500.<sup>00</sup></u>
<u>T &amp; G / Roof Sheathing:</u>	<u>\$ 15,620.<sup>00</sup></u>
<u> </u>	<u> </u>
<u> </u>	<u> </u>
<u> </u>	<u> </u>
<u> </u>	<u> </u>



SUBCONTRACTORS

The Bidder further proposes that the following subcontracting firms or businesses will be awarded subcontracts for the following portions of the work if the Bidder is awarded the Contract:

Keys Roofing, Inc.  
Name  
PO Box 371227 Key Largo FL 33037  
Street City State Zip

\_\_\_\_\_  
Name  
\_\_\_\_\_  
Street City State Zip

\_\_\_\_\_  
Name  
\_\_\_\_\_  
Street City State Zip

\_\_\_\_\_  
Name  
\_\_\_\_\_  
Street City State Zip

SURETY

Philadelphia Indemnity Insurance Company whose address is  
One Bala Plaza Suite 100, Bala Cynwyd, PA, 19004  
Street City State Zip

BIDDER

The name of the Bidder submitting this Bid is

Barracuda Builders of Key West, Inc. doing business at  
5601 3<sup>rd</sup> Avenue, Key West, FL, 33040  
Street City State Zip

which is the address to which all communications concerned with this Bid and with the Contract shall be sent.

The names of the principal officers of the corporation submitting this Bid, or of the partnership, or of all persons interested in this Bid as principals are as follows:

<u>Bryan Wofsey</u>	<u>President / owner</u>
_____	_____
_____	_____
_____	_____
_____	_____
_____	_____

If Sole Proprietor or Partnership

IN WITNESS hereto the undersigned has set his (its) hand this \_\_\_\_\_ day of \_\_\_\_\_ 2021.

\_\_\_\_\_  
Signature of Bidder

\_\_\_\_\_  
Title

If Corporation

IN WITNESS WHEREOF the undersigned corporation has caused this instrument to be executed and its seal affixed by its duly authorized officers this 10<sup>th</sup> day of November 2021.

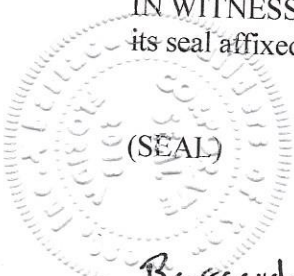

Barracuda Builders of Key West, Inc.  
Name of Corporation

By \_\_\_\_\_

Title President

Attest \_\_\_\_\_

Secretary



EXPERIENCE OF BIDDER

The Bidder states that he is an experienced CONTRACTOR and has completed similar projects within the last 5 years.

(List similar projects, with types, names of OWNERS, construction costs, ENGINEERS, and references with phone numbers. Use additional sheets if necessary.)

Blue Heron Park House Repairs, Monroe County, \$475,671.<sup>00</sup>

Smathers Beach Restrooms, City of Key West, \$538,044.<sup>90</sup>

Harbor Walk Flood Panels, City of Key West, \$46,184.<sup>46</sup>

1526 Washington Street Remodel, Bill Ciupinski, \$268,868.<sup>25</sup>

7 Boulder Drive Deck Replacement, Dale Finigan, \$30,957.<sup>45</sup>

Additional references provided by request ...

**FLORIDA BID BOND**

BOND NO. \_\_\_\_\_

AMOUNT: \$ 10,000.00

KNOW ALL MEN BY THESE PRESENTS, that Barracuda Builders of Key West, Inc.

hereinafter called the PRINCIPAL, and PHILADELPHIA INDEMNITY INSURANCE COMPANY

a corporation duly organized under the laws of the State of PA

having its principal place of business at ONE BALA PLAZA SUITE 100, BALA CYNWYD, PA 19004

\_\_\_\_\_ in the State of PA,

and authorized to do business in the State of Florida, as SURETY, are held and firmly bound unto

City of Key West

hereinafter called the OBLIGEE, in the sum of Ten Thousand & 00/100  
DOLLARS (\$ 10,000.00 ) for the payment for which we bind ourselves,  
our heirs, executors, administrators, successors, and assigns, jointly and severally, firmly by these  
present.

THE CONDITION OF THIS BOND IS SUCH THAT:

WHEREAS, the PRINCIPAL is herewith submitting his or its Bid for  
**ITB # 22-002 / C.B. HARVEY REST BEACH SHELTERS / IS72011901** said Bid, by  
reference thereto, being hereby made a part hereof.

WHEREAS, the PRINCIPAL contemplates submitting or has submitted a bid to the OBLIGEE for the furnishing of all labor, materials (except those to be specifically furnished by the CITY), equipment, machinery, tools, apparatus, means of transportation for, and the performance of the work covered in the Bid and the detailed Specifications, entitled:

**ITB 22-002 / C.B. HARVEY REST BEACH / IS72011901**

WHEREAS, it was a condition precedent to the submission of said bid that a cashier's check, certified check, or bid bond in the amount of five (5) percent of the base bid be submitted with said bid as a guarantee that the Bidder would, if awarded the Contract, enter into a written Contract with the CITY for the performance of said Contract, within 10 working days after written notice having been given of the award of the Contract.

NOW, THEREFORE, the conditions of this obligation are such that if the PRINCIPAL within 10 consecutive calendar days after written notice of such acceptance, enters into a written Contract with the OBLIGEE, then this obligation shall be void; otherwise the sum herein stated shall be due and payable to the OBLIGEE and the Surety herein agrees to pay said sum immediately upon demand of the OBLIGEE in good and lawful money of the United States of America, as liquidated damages for failure thereof of said PRINCIPAL.

Signed and sealed this 10th day of November, 2021.

PRINCIPAL  
Barracuda Builders of Key West, Inc.

By \_\_\_\_\_

STATE OF AZ )  
: SS  
COUNTY OF Maricopa )

PHILADELPHIA INDEMNITY INSURANCE COMPANY  
SURETY

By Valerie Ann Aber  
Valerie Ann Aber, Attorney-In-Fact

A NOTARY PUBLIC OR OTHER OFFICER COMPLETING THIS CERTIFICATE VERIFIES ONLY THE IDENTITY OF THE INDIVIDUAL WHO SIGNED THE DOCUMENT TO WHICH THIS CERTIFICATE IS ATTACHED, AND NOT THE TRUTHFULNESS, ACCURACY, OR VALIDITY OF THAT DOCUMENT

STATE OF ARIZONA  
COUNTY OF MARICOPA } SS.

ON 11/10/2021 BEFORE ME, Joshua Ferman

PERSONALLY APPEARED Valerie Ann Aber, ATTORNEY-IN-FACT

WHO PROVED TO ME ON THE BASIS OF SATISFACTORY EVIDENCE TO BE THE PERSON(S) WHOSE NAME(S) IS/ARE SUBSCRIBED TO THE WITHIN INSTRUMENT AND ACKNOWLEDGED TO ME THAT HE/SHE/THEY EXECUTED THE SAME IN HIS/HER/THEIR AUTHORIZED CAPACITY(IES) AND THAT BY HIS/HER/THEIR SIGNATURE(S) ON THE INSTRUMENT THE PERSON(S), OR THE ENTITY UPON BEHALF OF WHICH THE PERSON(S) ACTED, EXECUTED THE INSTRUMENT.

I CERTIFY UNDER PENALTY OF PERJURY UNDER THE LAWS OF THE STATE OF ARIZONA THAT THE FOREGOING PARAGRAPH IS TRUE AND CORRECT.

WITNESS MY HAND AND OFFICIAL SEAL.

SIGNATURE [Handwritten Signature]

THIS AREA FOR OFFICIAL NOTORIAL SEAL





**PHILADELPHIA INDEMNITY INSURANCE COMPANY**

One Bala Plaza, Suite 100  
Bala Cynwyd, PA 19004-0950

**Power of Attorney**

KNOW ALL PERSONS BY THESE PRESENTS: That **PHILADELPHIA INDEMNITY INSURANCE COMPANY** (the Company), a corporation organized and existing under the laws of the Commonwealth of Pennsylvania, does hereby constitute and appoint **Valerie Ann Aber and Daniel Rugge of Worldwide Insurance Specialists, Inc.** its true and lawful Attorney-in-fact with full authority to execute on its behalf bonds, undertakings, recognizances and other contracts of indemnity and writings obligatory in the nature thereof, issued in the course of its business and to bind the Company thereby, in an amount not to exceed **\$50,000,000.**

This Power of Attorney is granted and is signed and sealed by facsimile under and by the authority of the following Resolution adopted by the Board of Directors of **PHILADELPHIA INDEMNITY INSURANCE COMPANY** on the 14<sup>th</sup> of November, 2016.

**RESOLVED:** That the Board of Directors hereby authorizes the President or any Vice President of the Company: (1) Appoint Attorney(s) in Fact and authorize the Attorney(s) in Fact to execute on behalf of the Company bonds and undertakings, contracts of indemnity and other writings obligatory in the nature thereof and to attach the seal of the Company thereto; and (2) to remove, at any time, any such Attorney-in-Fact and revoke the authority given. And, be it

**FURTHER RESOLVED:** That the signatures of such officers and the seal of the Company may be affixed to any such Power of Attorney or certificate relating thereto by facsimile, and any such Power of Attorney so executed and certified by facsimile signatures and facsimile seal shall be valid and binding upon the Company in the future with respect to any bond or undertaking to which it is attached.

IN TESTIMONY WHEREOF, PHILADELPHIA INDEMNITY INSURANCE COMPANY HAS CAUSED THIS INSTRUMENT TO BE SIGNED AND ITS CORPORATE SEAL TO BE AFFIXED BY ITS AUTHORIZED OFFICE THIS 5TH DAY OF MARCH, 2021.

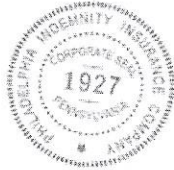

(Seal)

*John Glomb*  
John Glomb, President & CEO  
Philadelphia Indemnity Insurance Company

On this 5<sup>th</sup> day of March, 2021 before me came the individual who executed the preceding instrument, to me personally known, and being by me duly sworn said that he is the therein described and authorized officer of the **PHILADELPHIA INDEMNITY INSURANCE COMPANY**; that the seal affixed to said instrument is the Corporate seal of said Company; that the said Corporate Seal and his signature were duly affixed.

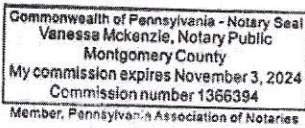

Notary Public: *Vanessa McKenzie*

residing at: Bala Cynwyd, PA

My commission expires: November 3, 2024

I, Edward Sayago, Corporate Secretary of **PHILADELPHIA INDEMNITY INSURANCE COMPANY**, do hereby certify that the foregoing resolution of the Board of Directors and the Power of Attorney issued pursuant thereto on the 5<sup>th</sup> day March, 2021 are true and correct and are still in full force and effect. I do further certify that John Glomb, who executed the Power of Attorney as President, was on the date of execution of the attached Power of Attorney the duly elected President of **PHILADELPHIA INDEMNITY INSURANCE COMPANY**.

In Testimony Whereof I have subscribed my name and affixed the facsimile seal of each Company this 10th day of October, 2021.



*Edward Sayago*  
Edward Sayago, Corporate Secretary  
**PHILADELPHIA INDEMNITY INSURANCE COMPANY**

VENDOR CERTIFICATION REGARDING  
SCRUTINIZED COMPANIES LISTS

Respondent Vendor Name: Barracuda Builders of Key West, Inc.  
Vendor FEIN: 46-1840239  
Vendor's Authorized Representative Name and Title: Bryan Wofscy / President  
Address: 5601 3rd Avenue  
City: Key West State: FL Zip: 33040  
Phone Number: 305 396-7752  
Email Address: info@barracudabuilders.com

Section 287.135(2)(a), Florida Statutes, prohibits a company from bidding on, submitting a proposal for, or entering into or renewing a contract for goods or services of any amount if, at the time of contracting or renewal, the company is on the Scrutinized Companies that Boycott Israel List, created pursuant to section 215.4725, Florida Statutes, or is engaged in a boycott of Israel. Section 287.135(2)(b), Florida Statutes, further prohibits a company from bidding on, submitting a proposal for, or entering into or renewing a contract for goods or services over one million dollars (\$1,000,000) if, at the time of contracting or renewal, the company is on either the Scrutinized Companies with Activities in Sudan List or the Scrutinized Companies with Activities in the Iran Petroleum Energy Sector List, both created pursuant to section 215.473, Florida Statutes, or the company is engaged in business operations in Cuba or Syria.

As the person authorized to sign on behalf of Respondent, I hereby certify that the company identified above in the section entitled "Respondent Vendor Name" is not listed on either the Scrutinized Companies that Boycott Israel List, Scrutinized Companies with Activities in Sudan List or the Scrutinized Companies with Activities in the Iran Petroleum Energy Sector List I understand that pursuant to section 287.135, Florida Statutes, the submission of a false certification may subject such company to civil penalties, attorney's fees, and/or costs and termination of the contract at the option of the awarding governmental entity.

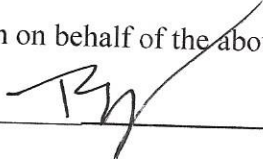
Certified By: Bryan Wofscy President  
*Print Name* *Print Title*  
who is authorized to sign on behalf of the above referenced company.  
Authorized Signature: 





SWORN STATEMENT UNDER SECTION 287.133(3)(A)  
FLORIDA STATUTES, ON PUBLIC ENTITY CRIMES

**THIS FORM MUST BE SIGNED IN THE PRESENCE OF A NOTARY PUBLIC OR OTHER OFFICER AUTHORIZED TO ADMINISTER OATHS.**

1. This sworn statement is submitted with Bid or Bid for C.B. Harvey Rest  
Beach Shelters (ITB # 22-002)
  
2. This sworn statement is submitted by Barracuda Builders of Key West, Inc.  
(Name of entity submitting sworn statement)  
whose business address is 5601 3rd Avenue  
Key West, FL 33040  
and (if applicable) its Federal Employer Identification Number (FEIN) is 46-1840239  
  
(If the entity has no FEIN, include the Social Security Number of the individual signing this sworn statement \_\_\_\_\_)
  
3. My name is Bryan Wolsky  
(Please print name of individual signing)  
and my relationship to the entity named above is President / owner
  
4. I understand that a "public entity crime" as defined in Paragraph 287.133(1)(g), Florida Statutes, means a violation of any state or federal law by a person with respect to and directly related to the transaction of business with any public entity or with an agency or political subdivision of any other state or with the United States, including but not limited to, any bid or contract for goods or services to be provided to any public or an agency or political subdivision of any other state or of the United States and involving antitrust, fraud, theft, bribery, collusion, racketeering, conspiracy, material misrepresentation.
  
5. I understand that "convicted" or "conviction" as defined in Paragraph 287.133(1)(b), Florida Statutes, means a finding of guilt or a conviction of a public entity crime, with or without an adjudication guilt, in any federal or state trial court of record relating to charges brought by indictment information after July 1, 1989, as a result of a jury verdict, nonjury trial, or entry of a plea of guilty or nolo contendere.



6. I understand that an "affiliate" as defined in Paragraph 287.133(1)(a), Florida Statutes, means
- a. A predecessor or successor of a person convicted of a public entity crime; or
  - b. An entity under the control of any natural person who is active in the management of the entity and who has been convicted of a public entity crime. The term "affiliate" includes those officers, directors, executives, partners, shareholders, employees, members, and agents who are active in the management of an affiliate. The ownership by one person of shares constituting controlling interest in another person, or a pooling of equipment or income among persons when not for fair market value under an arm's length agreement, shall be a prima facie case that one person controls another person. A person who knowingly enters into a joint venture with a person who has been convicted of a public entity crime in Florida during the preceding 36 months shall be considered an affiliate.
7. I understand that a "person" as defined in Paragraph 287.133(1)(8), Florida Statutes, means any natural person or entity organized under the laws of any state or of the United States with the legal power to enter into a binding contract and which bids or applies to bid on contracts for the provision of goods or services let by a public entity, or which otherwise transacts or applies to transact business with public entity. The term "person" includes those officers, directors, executives, partners, shareholders, employees, members, and agents who are active in management of an entity.
8. Based on information and belief, the statement which I have marked below is true in relation to the entity submitting this sworn statement. (Please indicate which statement applies).

Neither the entity submitting this sworn statement, nor any officers, directors, executives, partners, shareholders, employees, members, or agents who are active in management of the entity, nor any affiliate of the entity have been charged with and convicted of a public entity crime subsequent to July 1, 1989, AND (Please indicate which additional statement applies.)

There has been a proceeding concerning the conviction before a hearing of the State of Florida, Division of Administrative Hearings. The final order entered by the hearing officer did not place the person or affiliate on the convicted vendor list. (Please attach a copy of the final order.)

The person or affiliate was placed on the convicted vendor list. There has been a subsequent proceeding before a hearing officer of the State of

Florida, Division of Administrative Hearings. The final order entered by the hearing officer determined that it was in the public interest to remove the person or affiliate from the convicted vendor list. (Please attach a copy of the final order.)

The person or affiliate has not been put on the convicted vendor list. (Please describe any action taken by or pending with the Department of General Services.)

[Signature]  
(Signature)  
11 | 10 | 2021  
(Date)

STATE OF Florida

COUNTY OF Monroe

PERSONALLY, APPEARED BEFORE ME, the undersigned authority,

Bryan Woffsey who, after first being sworn by me, affixed his/her  
(Name of individual signing)

Signature in the space provided above on this 11<sup>th</sup> day of November, 2021.

My commission expires:

[Signature]  
NOTARY PUBLIC



INDEMNIFICATION

To the fullest extent permitted by law, the CONTRACTOR expressly agrees to indemnify and hold harmless the City of Key West, their officers, directors, agents, and employees (herein called the "indemnitees") from liabilities, damages, losses and costs, including, but not limited to, reasonable attorney's fees and court costs, such legal expenses to include costs incurred in establishing the indemnification and other rights agreed to in this Paragraph, to persons or property, to the extent caused by the negligence, recklessness, or intentional wrongful misconduct of the CONTRACTOR, its Subcontractors or persons employed or utilized by them in the performance of the Contract. Claims by indemnitees for indemnification shall be limited to the amount of CONTRACTOR's insurance or \$1 million per occurrence, whichever is greater. The parties acknowledge that the amount of the indemnity required hereunder bears a reasonable commercial relationship to the Contract and it is part of the project specifications or the bid documents, if any.

The indemnification obligations under the Contract shall not be restricted in any way by any limitation on the amount or type of damages, compensation, or benefits payable by or for the CONTRACTOR under workers' compensation acts, disability benefits acts, or other employee benefits acts, and shall extend to and include any actions brought by or in the name of any employee of the CONTRACTOR or of any third party to whom CONTRACTOR may subcontract a part or all of the Work. This indemnification shall continue beyond the date of completion of the work. Nothing contained in this paragraph is intended to nor shall it constitute a waiver of the State of Florida and the CITY's sovereign immunity.

CONTRACTOR: Barracuda Builders of Key West, Inc. SEAL:

5601 3<sup>rd</sup> Avenue, Key West, FL 33040  
Address

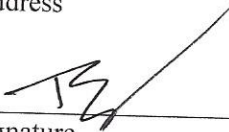
  
Signature

Bryan Wofsey  
Print Name

President  
Title

DATE: 11 | 10 | 2021



**LOCAL VENDOR CERTIFICATION PURSUANT TO CKW ORDINANCE 09-22 SECTION 2-798**

The undersigned, as a duly authorized representative of the vendor listed herein, certifies to the best of his/her knowledge and belief, that the vendor meets the definition of a "Local Business." For purposes of this section, "local business" shall mean a business which:

- a. Principle address as registered with the FL Department of State located within 30 miles of the boundaries of the city, listed with the chief licensing official as having a business tax receipt with its principle address within 30 miles of the boundaries of the city for at least one year immediately prior to the issuance of the solicitation.
- b. Maintains a workforce of at least 50 percent of its employees from the city or within 30 miles of its boundaries.
- c. Having paid all current license taxes and any other fees due the city at least 24 hours prior to the publication of the call for bids or request for Bids.
  - Not a local vendor pursuant to Ordinance 09-22 Section 2-798
  - Qualifies as a local vendor pursuant to Ordinance 09-22 Section 2-798

If you qualify, please complete the following in support of the self-certification & submit copies of your County and City business licenses. Failure to provide the information requested will result in denial of certification as a local business.

Business Name Barracuda Builders of Key West, Inc. Phone: 305 396 7752

Current Local Address: 5601 3<sup>rd</sup> Avenue, Key West, FL 33040 Fax: 305 396 7832  
(P.O. Box numbers may not be used to establish status)

Length of time at this address: 9 years

[Signature] Date: 11/10/2021  
Signature of Authorized Representative

STATE OF Florida COUNTY OF Monroe

The foregoing instrument was acknowledged before me this \_\_\_\_\_ day of \_\_\_\_\_, 2021.

By Bryan Wofscy, President of Barracuda Builders of Key West, Inc.  
(Name of officer or agent, title of officer or agent) (Name of corporation acknowledging)

or has produced identification personally known as identification  
(Type of identification)

[Signature]  
Signature of Notary

Return Completed form with Supporting documents to:  
City of Key West Purchasing









**Sec. 2-773. Cone of silence.**

- (a) *Definitions.* For purposes of this section, reference to one gender shall include the other, use of the plural shall include the singular, and use of the singular shall include the plural. The following definitions apply unless the context in which the word or phrase is used requires a different definition:
- (1) *Competitive solicitation* means a formal process by the City of Key West relating to the acquisition of goods or services, which process is intended to provide an equal and open opportunity to qualified persons and entities to be selected to provide the goods or services. Competitive solicitation shall include request for proposals ("RFP"), request for qualifications ("RFQ"), request for letters of interest ("RFLI"), invitation to bid ("ITB") or any other advertised solicitation.
  - (2) *Cone of silence* means a period of time during which there is a prohibition on communication regarding a particular competitive solicitation.
  - (3) *Evaluation or selection committee* means a group of persons appointed or designated by the city to evaluate, rank, select, or make a recommendation regarding a vendor or the vendor's response to the competitive solicitation. A member of such a committee shall be deemed a city official for the purposes of subsection (c) below.
  - (4) *Vendor* means a person or entity that has entered into or that desires to enter into a contract with the City of Key West or that seeks an award from the city to provide goods, perform a service, render an opinion or advice, or make a recommendation related to a competitive solicitation for compensation or other consideration.
  - (5) *Vendor's representative* means an owner, individual, employee, partner, officer, or member of the board of directors of a vendor, or a consultant, lobbyist, or actual or potential subcontractor or sub-consultant who acts at the behest of a vendor in communicating regarding a competitive solicitation.
- (b) *Prohibited communications.* A cone of silence shall be in effect during the course of a competitive solicitation and prohibit:
- (1) Any communication regarding a particular competitive solicitation between a potential vendor or vendor's representative and the city's administrative staff including, but not limited to, the city manager and his or her staff;
  - (2) Any communication regarding a particular competitive solicitation between a potential vendor or vendor's representative and the mayor, city commissioners, or their respective staff;
  - (3) Any communication regarding a particular competitive solicitation between a potential vendor or vendor's representative and any member of a city evaluation and/or selection committee therefore; and
  - (4) Any communication regarding a particular competitive solicitation between the mayor, city commissioners, or their respective staff, and a member of a city evaluation and/or selection committee therefore.
- (c) *Permitted communications.* Notwithstanding the foregoing, nothing contained herein shall prohibit:
- (1) Communication between members of the public who are not vendors or a vendor's representative and any city employee, official or member of the city commission;

- (2) Communications in writing at any time with any city employee, official or member of the city commission, unless specifically prohibited by the applicable competitive solicitation.
    - (A) However, any written communication must be filed with the city clerk. Any city employee, official or member of the city commission receiving or making any written communication must immediately file it with the city clerk.
    - (B) The city clerk shall include all written communication as part of the agenda item when publishing information related to a particular competitive solicitation;
  - (3) Oral communications at duly noticed pre-bid conferences;
  - (4) Oral presentations before publicly noticed evaluation and/or selection committees;
  - (5) Contract discussions during any duly noticed public meeting;
  - (6) Public presentations made to the city commission or advisory body thereof during any duly noticed public meeting;
  - (7) Contract negotiations with city staff following the award of a competitive solicitation by the city commission; or
  - (8) Purchases exempt from the competitive process pursuant to section 2-797 of these Code of Ordinances;
- (d) *Procedure.*
- (1) The cone of silence shall be imposed upon each competitive solicitation at the time of public notice of such solicitation as provided by section 2-826 of this Code. Public notice of the cone of silence shall be included in the notice of the competitive solicitation. The city manager shall issue a written notice of the release of each competitive solicitation to the affected departments, with a copy thereof to each commission member, and shall include in any public solicitation for goods and services a statement disclosing the requirements of this ordinance.
  - (2) The cone of silence shall terminate:
    - (A) At the time the city commission or other authorized body makes final award or gives final approval of a contract, rejects all bids or responses to the competitive solicitation, or takes other action which ends the competitive solicitation.
    - (B) At the deadline for submission of responses to the solicitation if only one vendor has responded.
  - (3) Any city employee, official or member of the city commission that is approached concerning a competitive solicitation while the cone of silence is in effect shall notify such individual of the prohibitions contained in this section. While the cone of silence is in effect, any city employee, official or member of the city commission who is the recipient of any oral communication by a potential vendor or vendor's representative in violation of this section shall create a written record of the event. The record shall indicate the date of such communication, the persons with whom such communication occurred, and a general summation of the communication.
- (e) *Violations/penalties and procedures.*
- (1) A sworn complaint alleging a violation of this ordinance may be filed with the city attorney's office. In each such instance, an initial investigation shall be performed to determine the existence of a violation. If a violation is found to exist, the penalties and process shall be as provided in section 1-15 of this Code.
  - (2) In addition to the penalties described herein and otherwise provided by law, a violation of this ordinance shall render the competitive solicitation void at the discretion of the city commission.



- (3) Any person who violates a provision of this section shall be prohibited from serving on a City of Key West advisory board, evaluation and/or selection committee.
  - (4) In addition to any other penalty provided by law, violation of any provision of this ordinance by a City of Key West employee shall subject said employee to disciplinary action up to and including dismissal.
  - (5) If a vendor is determined to have violated the provisions of this section on two more occasions it shall constitute evidence under City Code section 2-834 that the vendor is not properly qualified to carry out the obligations or to complete the work contemplated by any new competitive solicitation. The city's purchasing agent shall also commence any available debarment from city work proceeding that may be available upon a finding of two or more violations by a vendor of this section.
- (Ord. No. 13-11, § 1, 6-18-2013; Ord. No. 19-08, § 1, 3-20-2019; Ord. No. 19-28, § 3, 9-17-2019)



## BIDDER'S CHECKLIST

(Note: The purpose of this checklist is to serve as a reminder of major items to be addressed in submitting a bid and is not intended to be all inclusive. It does not alleviate the Bidder from the responsibility of becoming familiar with all aspects of the Contract Documents and proper completion and submission of his bid.)

1. All Contract Documents thoroughly read and understood. [ ✓ ]
2. All blank spaces in Bid filled in, using black ink. [ ✓ ]
3. Total and unit prices added correctly and attached Schedule of Values [ ✓ ]
4. Addenda acknowledged. [ ✓ ]
5. Subcontractors are named as indicated in the Bid. [ ✓ ]
6. Experience record included. [ ✓ ]
7. Bid signed by authorized officer. [ ✓ ]
8. Bid Bond completed and executed, including power-of-attorney dated the same date as Bid Bond. [ ✓ ]
9. Bidder familiar with federal, state, and local laws, ordinances, rules and regulations affecting performance of the work. [ ✓ ]
10. Bidder, if successful, able to obtain and/or demonstrate possession of required licenses and certificates within (10) ten calendar days after receiving a Notice of Award. [ ✓ ]
11. BID submitted intact with the volume entitled "Bidding Requirements" and "Contract Forms", 1 original, and 2 flash drives as stated in the invitation to bid. [ ✓ ]
12. Bid Documents submitted in sealed envelope and addressed and labeled in conformance with the instructions in the Invitation to Bid. [ ✓ ]





Ron DeSantis, Governor

Halsey Beshears, Secretary



**STATE OF FLORIDA**  
**DEPARTMENT OF BUSINESS AND PROFESSIONAL REGULATION**

**CONSTRUCTION INDUSTRY LICENSING BOARD**

THE GENERAL CONTRACTOR HEREIN IS CERTIFIED UNDER THE  
PROVISIONS OF CHAPTER 489, FLORIDA STATUTES

**WOFSEY, BRYAN ROBERT**

BARRACUDA BUILDERS OF KEY WEST, INC.  
5601 3RD AVENUE  
KEY WEST FL 33040

**LICENSE NUMBER: CGC1521253**

**EXPIRATION DATE: AUGUST 31, 2022**

Always verify licenses online at [MyFloridaLicense.com](http://MyFloridaLicense.com)



Do not alter this document in any form.

This is your license. It is unlawful for anyone other than the licensee to use this document.

**2021 / 2022  
MONROE COUNTY BUSINESS TAX RECEIPT  
EXPIRES SEPTEMBER 30, 2022**

Business Name: BARRACUDA BUILDERS OF KEY WEST INC      RECEIPT# 30140-110014

Owner Name: BRYAN ROBERT WOFSEY      Business Location: 5601 3RD AVE  
Mailing Address: KEY WEST, FL 33040

5601 3RD AVE      Business Phone: 305-396-7752  
KEY WEST, FL 33040      Business Type: CONTRACTOR (CERTIFIED GENERAL CONTRACTOR)

Employees 1

STATE LICENSE: CGC1521253

Tax Amount	Transfer Fee	Sub-Total	Penalty	Prior Years	Collection Cost	Total Paid
20.00	0.00	20.00	0.00	0.00	0.00	20.00

**Paid 102-20-00004112 07/14/2021 20.00**

THIS BECOMES A TAX RECEIPT  
WHEN VALIDATED

**Sam C. Steele, CFC, Tax Collector  
PO Box 1129, Key West, FL 33041**

THIS IS ONLY A TAX.  
YOU MUST MEET ALL  
COUNTY AND/OR  
MUNICIPALITY  
PLANNING, ZONING AND  
LICENSING  
REQUIREMENTS.

**MONROE COUNTY BUSINESS TAX RECEIPT**

P.O. Box 1129, Key West, FL 33041-1129

EXPIRES SEPTEMBER 30, 2022

Business Name: BARRACUDA BUILDERS OF KEY WEST INC      RECEIPT# 30140-110014

Owner Name: BRYAN ROBERT WOFSEY      Business Location: 5601 3RD AVE  
Mailing Address: KEY WEST, FL 33040

5601 3RD AVE      Business Phone: 305-396-7752  
KEY WEST, FL 33040      Business Type: CONTRACTOR (CERTIFIED GENERAL CONTRACTOR)

Employees 1

STATE LICENSE: CGC1521253

Tax Amount	Transfer Fee	Sub-Total	Penalty	Prior Years	Collection Cost	Total Paid
20.00	0.00	20.00	0.00	0.00	0.00	20.00

**Paid 102-20-00004112 07/14/2021 20.00**

---

---

**PART 2**

**CONTRACT FORMS**

---

---



**CONTRACT**

This Contract, made and entered into this \_\_\_\_\_ day of \_\_\_\_\_ 2021,

by and between the CITY OF KEY WEST, hereinafter called the "Owner", and \_\_\_\_\_

---

hereinafter called the "Contractor";

WITNESSETH:

The Contractor, in consideration of the sum to be paid to them by the Owner and of the covenants and agreements herein contained, hereby agrees at his own proper cost and expense to do all the work and furnish all the materials, tools, labor, and all appliances, machinery, and appurtenances for ITB 22-002 C.B. HARVEY REST BEACH SHELTERS, Key West, Florida to the extent of the Bid made by the Contractor, dated the \_\_\_\_\_th day of \_\_\_\_\_ 2021, all in full compliance with the Contract Documents referred to herein.

The CONTRACT DOCUMENTS, including the signed copy of the BID, BID BOND, CONTRACT FORM, SUMMARY OF WORK, SPECIFICATIONS, DRAWINGS, GENERAL & SUPPLEMENTARY CONDITIONS OF THE CONTRACT.

In consideration of the performance of the work as set forth in these Contract Documents, the Owner agrees to pay to the Contractor the amount bid in the Bid as adjusted in accordance with the Contract Documents, or as otherwise herein provided, and to make such payments in the manner and at the times provided in the Contract Documents.

The Contractor agrees to complete the work within One hundred & eighty (180) days and to accept as full payment hereunder the amounts computed as determined by the Contract Documents and based on the said BID.

The Contractor agrees to remedy all defects appearing in the work or developing in the materials furnished and the workmanship performed under this Contract during the warranty period after the date of final acceptance of the work by the Owner, and further agrees to indemnify and save the Owner harmless from any costs encountered in remedying such defects.

It is agreed that the Contract, based upon the BID, shall be fully complete within the stated number of consecutive calendar days from the date the Notice to Proceed is issued.

In the event the Contractor fails to complete the work within the time limit or extended time limit agreed upon, as more particularly set forth in the Contract Documents, liquidated damages shall be paid at a rate of \$250.00 per day. Sundays and legal holidays shall be included in determining days in default.

This contract will automatically expire upon completion of the project. Contractors warranty obligations remain in effect.

-Public Access. Pursuant to Florida Statute §119.0701, the parties shall comply with all public records laws of the State of Florida, including but not limited to:

- i. Keep and maintain public records that ordinarily and necessarily would be required by CITY in the performance of this Agreement.
- ii. Provide the public with access to public records on the same terms and conditions that CITY would provide the records and at a cost that does not exceed the cost provided in Florida Statutes, Chapter 119 or as otherwise provided by law.
- iii. Ensure that public records that are exempt or confidential and exempt from public records disclosure requirements are not disclosed except as authorized by law.
- iv. Meet all requirements for retaining public records and transfer, at no cost, to CITY, all public records in possession of CONTRACTOR upon termination of this Agreement and destroy any duplicate public records that are exempt or confidential and exempt from public records disclosure requirements. All records stored electronically must be provided to CONTRACTOR in a format that is compatible with the information technology systems of CONTRACTOR.

-Governing Laws/Venue. This Agreement is governed by the laws of the State of Florida and the United States. Venue for any dispute arising under this Agreement shall be in Monroe County, Florida. Nothing contained herein shall be construed to alter or waive the City's sovereign immunity under 768.28, Florida Statutes.

-Construction. This Agreement has been carefully reviewed by each of the parties. Therefore, this Agreement is not to be construed against any party on the basis of authorship.

IN WITNESS WHEREOF, we, the parties hereto, each herewith subscribe the same this

\_\_\_\_\_ Day of \_\_\_\_\_, A.D., 2021.

CITY OF KEY WEST

By \_\_\_\_\_

Title City Manager

CONTRACTOR

By \_\_\_\_\_

Title \_\_\_\_\_



---

---

**PART 3**

**CONDITIONS OF THE CONTRACT**

---

---

GENERAL CONDITIONS  
CONTENTS

**Article**

**DEFINITIONS**

1. AS APPROVED
2. AS SHOWN, AND AS INDICATED
3. BIDDER
4. CONTRACT DOCUMENTS
5. CONTRACTOR
6. CONTRACT COMPLETION
7. DAYS
8. DRAWINGS
9. ENGINEER
10. NOTICE
11. OR EQUAL
12. OWNER
13. PLANS
14. SPECIFICATIONS
15. NOTICE TO PROCEED
16. SUBSTANTIAL COMPLETION
17. WORK

**CONTRACT DOCUMENTS**

18. INTENT OF CONTRACT DOCUMENTS
19. DISCREPANCIES AND OMISSIONS
20. CHANGES IN THE WORK
21. EXAMINATION AND VERIFICATION OF CONTRACT DOCUMENTS
22. DOCUMENTS TO BE KEPT ON THE JOBSITE
23. ADDITIONAL CONTRACT DOCUMENTS
24. OWNERSHIP OF CONTRACT DOCUMENTS

**THE ENGINEER**

25. AUTHORITY OF THE ENGINEER
26. DUTIES AND RESPONSIBILITIES OF THE ENGINEER
27. LIMITATIONS ON ENGINEER'S RESPONSIBILITIES
28. REJECTED WORK
29. LINES AND GRADES
30. SUBMITTALS
31. DETAIL DRAWINGS AND INSTRUCTIONS

**THE CONTRACTOR AND HIS EMPLOYEES**

32. CONTRACTOR, AN INDEPENDENT AGENT
32. (a) ASSIGNMENT OF CONTRACT

33. SUBCONTRACTING
34. INSURANCE AND LIABILITY
  - A. GENERAL
  - B. CONTRACTOR AND SUB-CONTRACTOR INSURANCE
  - C. COMPENSATION AND EMPLOYER'S LIABILITY INSURANCE
  - D. GENERAL LIABILITY INSURANCE (INCLUDING AUTOMOBILE)
  - E. BUILDER'S RISK ALL RISK INSURANCE
  - F. NO PERSONAL LIABILITY OF PUBLIC OFFICIALS
35. INDEMNITY
36. EXCLUSION OF CONTRACTOR CLAIMS
37. TAXES AND CHARGES
38. REQUIREMENTS OF STATE LAW FOR PUBLIC WORKS PROJECTS
39. CODES, ORDINANCES, PERMITS, AND LICENSES
40. SUPERINTENDENCE
41. RECEPTION OF ENGINEER'S COMMUNICATIONS
42. SAFETY
43. PROTECTION OF WORK AND PROPERTY
44. RESPONSIBILITY OF CONTRACTOR TO ACT IN AN EMERGENCY
45. MATERIALS AND APPLIANCES
46. CONTRACTORS' AND MANUFACTURERS' COMPLIANCE WITH STATE SAFETY, OSHA AND OTHER CODE REQUIREMENTS
47. SUBSTITUTION OF MATERIALS
48. TESTS, SAMPLES, AND OBSERVATIONS
49. ROYALTIES AND PATENT
50. CONTRACTOR'S RIGHT TO TERMINATE CONTRACT
51. CORRECTION OF DEFECTIVE WORK DURING WARRANTY PERIOD

**PROGRESS OF THE WORK**

52. BEGINNING OF THE WORK
53. SCHEDULES AND PROGRESS REPORTS
54. PROSECUTION OF THE WORK
55. OWNER'S RIGHT TO RETAIN IMPERFECT WORK
56. OWNER'S RIGHT TO DO WORK
57. OWNER'S RIGHT TO TRANSFER EMPLOYMENT
58. DELAYS AND EXTENSION OF TIME
59. DIFFERING SITE CONDITION

GENERAL CONDITIONS  
CONTENTS

**Article**

- 60. LIQUIDATED DAMAGES
- 61. OTHER CONTRACTS
- 62. USE OF PREMISES
- 63. SUBSTANTIAL COMPLETION DATE
- 64. PERFORMANCE TESTING
- 65. OWNER'S USE OF PORTION OF THE WORK
- 66. CUTTING AND PATCHING
- 67. CLEANING UP

**PAYMENT**

- 68. CHANGE ORDERS
  - A. UNIT PRICE
  - B. LUMP SUM
  - C. COST REIMBURSEMENT  
WORK
- 69. PARTIAL PAYMENTS
  - A. GENERAL
  - B. ESTIMATE
  - C. DEDUCTION FROM ESTIMATE
  - D. QUALIFICATIONS FOR  
PARTIAL PAYMENT FOR  
MATERIALS DELIVERED
  - E. PAYMENT
- 70. CLAIMS FOR EXTRA WORK
- 71. RELEASE OF LIENS OR CLAIMS
- 72. FINAL PAYMENT
- 73. NO WAIVER OF RIGHTS
- 74. ACCEPTANCE OF FINAL PAYMENT  
CONSTITUTES RELEASE

GENERAL CONDITIONS  
CONTENTS

**DEFINITIONS**

Whenever in the Contract Documents the following terms are used, the intent and meaning shall be interpreted as follows:

**1. AS APPROVED**

The words “as approved”, unless otherwise qualified, shall be understood to be followed by the words “by the ENGINEER for conformance with the Contract Document”.

**2. AS SHOWN, AND AS INDICATED**

The words “as shown” and “as Indicated” shall be understood to be followed by the words “on the Drawings”.

**3. BIDDER**

The person or persons, partnership, firm, or corporation submitting a Bid for the work contemplated.

**4. CONTRACT DOCUMENTS**

The “Contract Documents” consist of the Bidding Requirements, Contract Forms, Conditions of the Contract, Specifications, Drawings, all modifications thereof incorporated into the Documents before their execution, Change Orders, and all other requirements incorporated by specific reference thereto. These form the Contract.

**5. CONTRACTOR**

The person or persons, partnership, firm, or corporation who enters into the Contract awarded him by the OWNER.

**6. CONTRACT COMPLETION**

The “Contract Completion” is the date the OWNER accepts the entire work as being in compliance with the Contract Documents, or formally waives nonconforming work to extent of nonconformity, and issues the final payment in accordance with the requirements set forth in Article, “Final Payment” of these General Conditions.

**7. DAYS**

Unless otherwise specifically stated, the term “days” will be understood to mean calendar days. Business day or working day means any day other than Saturday, Sunday, or legal holiday.

**8. DRAWINGS**

The term “Drawings” refers to the official Drawings, Profiles, cross sections, elevations, details, and other working drawings and supplementary drawings, or reproductions thereof, signed by the ENGINEER, which shows the location, character, dimensions, and details of the work to be performed. Drawings may either be bound in the same book as the balance of the Contract Documents, or bound in separate sets, and are a part of the Contract Documents, regardless of the method of binding.

**9. ENGINEER**

The person or organization identified as such in the Contract Documents. The Term “ENGINEER” means ENGINEER or his authorized representative.

**10. NOTICE**

The term “notice” or the requirement to notify, as used in the Contract Documents or applicable state or federal statutes, shall signify a written communication delivered in person or by registered mail to the individual, or to a member of the firm, or to an officer of the corporation for whom it is intended. Certified or registered mail shall be addressed to the last business address known to him

GENERAL CONDITIONS  
CONTENTS

who gives the notice.

**11. OR EQUAL**

The term “or equal” shall be understood to indicate that the “equal” Product is equivalent to or better than the Product named in function, performance, reliability, quality, and general configuration. Determination of equality in reference to the Project design requirements will be made by the ENGINEER. Such equal Products shall not be purchased or installed by the CONTRACTOR without written authorization.

**12. OWNER**

The person, organization, or public body identified as such in the Contract Documents.

**13. PLANS (See Drawings)**

**14. SPECIFICATIONS**

The term “Specifications” refers to those portions of the Contract Documents consisting of written technical descriptions of materials, equipment, construction systems, standards, and workmanship as applied to the work and certain administrative details applicable thereto. Where standard specifications, such as those of ASTM, AASHTO, etc., have been referred to, the applicable portions of such standard specifications shall become a part of these Contract Documents. If referenced specifications conflict with specifications contained herein, the requirements contained herein shall prevail.

**15. NOTICE TO PROCEED**

A written notice given by the OWNER to the CONTRACTOR (with a copy to the ENGINEER) fixing the date on which the Contract time will commence to run and on which the CONTRACTOR shall start to perform his obligation under the Contract Documents. The Notice to Proceed will be given within 30 days following the execution of the Contract by the OWNER.

**16. SUBSTANTIAL COMPLETION**

“Substantial Completion” shall be that degree of completion of the Project or a defined portion of the Project, as evidenced by the ENGINEER’s written notice of Substantial Completion, sufficient to Provide the OWNER, at his discretion, the full-time use of the Project or defined portion of the Project for the purposes for which it was intended. “Substantial Completion” of an operating facility shall be that degree of completion that has Provided a minimum of 7 continuous days of successful, trouble-free, operation, which period shall begin after all performance and acceptance testing has been successfully demonstrated to the ENGINEER. All equipment contained in the work, plus all other components necessary to enable the OWNER to operate the facility in a manner that was intended, shall be complete on the substantial completion date.

**17. WORK**

The word “work” within these Contract Documents shall include all material, labor, tools, and all appliances, machinery, transportation, and appurtenances necessary to perform and complete the Contract, and such additional items not specifically indicated or described which can be reasonably inferred as belonging to the item described or indicated and as required by good Practice to Provide a complete and satisfactory system or structure. As used herein, “Provide” shall be understood to mean “furnish and install, complete in-place “.

**CONTRACT DOCUMENTS**

**18. INTENT OF CONTRACT DOCUMENTS**

The Contract Documents are complementary, and what is called for by one shall be as binding as if called for by all. The intent of the Documents is to describe a functionally complete Project (or part thereof) to be constructed in accordance with the Contract Documents. Any work, materials, or equipment that may reasonably be inferred from the Contract Documents as being required to produce the intended result shall be supplied whether or not specifically called for. When words which have a well-known technical



GENERAL CONDITIONS  
CONTENTS

or trade meaning are used to describe work, materials, or equipment, such words shall be interpreted in accordance with that meaning.

Reference to standard specifications, manuals, or codes of any technical society, organization or association, or to the laws or regulations of any governmental authority, whether such reference be specific or by implication, shall mean the latest standard specification, manual, code or laws or regulations in effect on the first published date of the Invitation to Bid, except as may be otherwise specifically stated. However, no Provision of any referenced standard specification, manual or code (whether or not specifically incorporated by reference in the Contract Documents) shall be effective to change the duties and responsibilities of OWNER, CONTRACTOR, or ENGINEER, or any of their consultants, agents, or employees from those set forth in the Contract Documents, nor shall it be effective to assign to ENGINEER, or any ENGINEER's consultants, agents, or employees, any duty or authority to supervise or direct the furnishing or performance of the work or any duty or authority to undertake responsibility contrary to the Provisions of Article LIMITATIONS ON ENGINEER'S RESPONSIBILITIES.

**19. DISCREPANCIES AND OMISSIONS**

Any discrepancies or omissions found in the Contract Documents shall be reported to the ENGINEER immediately. The ENGINEER will clarify discrepancies or omissions, in writing, within a reasonable time.

In resolving inconsistencies among two or more sections of the Contract Documents, Precedence shall be given in the following order:

- A. CONTRACT
- B. BID
- C. SUPPLEMENTARY CONDITIONS
- D. INVITATION TO BID
- E. INSTRUCTIONS TO BIDDERS
- F. GENERAL CONDITIONS
- G. SPECIFICATIONS
- H. DRAWINGS

Addenda shall take Precedence over all sections referenced therein. Figure dimensions on Drawings shall take precedence over scale dimensions. Detailed Drawings shall take precedence over general Drawings.

**20. CHANGES IN THE WORK**

The OWNER, without notice to the Sureties and without invalidating the Contract, may order changes in the work within the general scope of the Contract by altering, adding to, or deducting from the work, the Contract being adjusted accordingly. All such work shall be executed under the conditions of the original Contract, except as specifically adjusted at the time of ordering such change.

In giving instructions, the ENGINEER may order minor changes in the work not involving extra cost and not inconsistent with the purposes of the Project, but otherwise, except in an emergency endangering life and Property, additions or deductions from the work shall be performed only in pursuance of an approved Change Order from the OWNER, countersigned by the ENGINEER.

If the work is reduced by alterations, such action shall not constitute a claim for damages based on loss of anticipated Profits.

**21. EXAMINATION AND VERIFICATION OF CONTRACT DOCUMENTS**

The CONTRACTOR shall thoroughly examine and become familiar with all of the various parts of these Contract Documents and determine the nature and location of the work, the general and local conditions, and all other matters, which can in any way affect the work under this Contract. Failure to make an examination necessary for this determination shall not release the CONTRACTOR from the obligations of this Contract. No verbal agreement or conversation with any officer, agent, or employee of the OWNER or with the ENGINEER either before or after the execution of this Contract shall affect or modify any of the terms or obligations herein contained.

**22. DOCUMENTS TO BE KEPT ON THE JOBSITE**

The CONTRACTOR shall keep one copy of the Contract Documents on the job- site, in good order, available to the ENGINEER

GENERAL CONDITIONS  
CONTENTS

and to his representatives.

The CONTRACTOR shall maintain on a daily basis at the jobsite, and make available to the ENGINEER on request, one current record set of the Drawings which have been accurately marked to indicate all modifications in the completed work that differ from the design information shown on the Drawings. Upon Substantial completion of the work, the CONTRACTOR shall give the ENGINEER one complete set of these marked up record Drawings.

**23. ADDITIONAL CONTRACT DOCUMENTS**

Copies of Contract Documents or Drawings may be obtained on request from the ENGINEER and by paying the actual cost of reproducing the Contract Documents or Drawings.

**24. OWNERSHIP OF CONTRACT DOCUMENTS**

All portions of the Contract Documents, and copies thereof furnished by the ENGINEER are instruments of service for this Project. They are not to be used on other work and are to be returned to the ENGINEER on request at the completion of the work. Any reuse of these materials without specific written verification or adaptation by the ENGINEER will be at the risk of the user and without liability or legal expense to the ENGINEER. Such user shall hold the ENGINEER harmless from any and all damages, including reasonable attorneys' fees, from any and all claims arising from any such reuse. Any such verification and adaptation shall entitle the ENGINEER to further compensation at rates to be agreed upon by the user and the ENGINEER.

**THE ENGINEER**

**25. AUTHORITY OF THE ENGINEER**

The ENGINEER will be the OWNER's representative during the construction period. His authority and responsibility will be limited to the Provisions set forth in these Contract Documents. The ENGINEER will have the Authority to reject work that does not conform to the Contract Documents. However, neither the ENGINEER's authority to act under this Provision, nor any decision made by him in good faith either to exercise or not to exercise such authority, shall give rise to any duty or responsibility of the ENGINEER to the CONTRACTOR, any SUBCONTRACTOR, their respective Sureties, any of their agents or employees, or any other person performing any of the work.

**26. DUTIES AND RESPONSIBILITIES OF THE ENGINEER**

The ENGINEER will make visits to the site at intervals appropriate to the various stages of construction to observe the Progress and quality of the work and to determine, in general, if the work is proceeding in accordance with the intent of the Contract Documents. He will not make comprehensive or continuous review or observation to check quality or quantity of the work, and he will not be responsible for construction means, methods, techniques, sequences, or Procedures, or for safety Precautions and Programs in connection with the work. Visits and observations made by the ENGINEER shall not relieve the CONTRACTOR of his obligation to conduct comprehensive inspections of the work and to furnish materials and perform acceptable work, and to provide adequate safety Precautions, in conformance with the intent of the Contract.

The ENGINEER will make recommendations to the OWNER, in writing, on all claims of the OWNER or the CONTRACTOR arising from interpretation or execution of the Contract Documents. Such recommendations will be of factual and/or technical nature, and will not include the legal interpretation of the Contract Documents. Any necessary legal interpretation of the Contract Document will be made by the OWNER. Such recommendation shall be necessary before the CONTRACTOR can receive additional money under the terms of the Contract. Changes in work ordered by the ENGINEER shall be made in compliance with Article CHANGES IN THE WORK.

One or more Project representatives may be assigned to observe the work. It is understood that such Project representatives shall have the authority to issue notice of nonconformance and make decisions within the limitations of the authority of the ENGINEER. The CONTRACTOR shall furnish all reasonable assistance required by the ENGINEER or Project representatives for Proper observation of the work. The above-mentioned Project representatives shall not relieve the CONTRACTOR of his obligations to conduct comprehensive inspections of the work and to furnish materials and perform acceptable work, and to provide adequate safety Precautions, in conformance with the intent of the Contract.

GENERAL CONDITIONS  
CONTENTS

**27. LIMITATIONS ON ENGINEER'S RESPONSIBILITIES**

ENGINEER will not be responsible for CONTRACTOR's means, methods, techniques, sequences, or Procedures of construction, or the safety Precautions and Programs incident thereto, and ENGINEER will not be responsible for CONTRACTOR's failure to perform or furnish the work in accordance with the Contract Documents.

ENGINEER will not be responsible for the acts or omissions of CONTRACTOR or of any SUBCONTRACTOR, any supplier, or of any other person or organization performing or furnishing any of the work.

Whenever in the Contract Documents the terms "as ordered", "as directed", "as required", "as allowed", "as approved", or terms of like effect or import are used, or the adjectives "reasonable", "suitable", "acceptable", "Proper", or "satisfactory", or adjectives of like effect or import are used to describe a requirement, direction, review or judgment of ENGINEER as to the work, it is intended that such requirement, direction, review or judgment will be solely to evaluate the work for compliance with the Contract Documents (unless there is a specific statement indicating otherwise). The use of any such term or adjective shall not be effective to assign to ENGINEER any duty or authority to supervise or direct the furnishing or performance of the work or any duty or authority to undertake responsibility contrary to the Provisions of this Article.

**28. REJECTED WORK**

Any defective work or nonconforming materials or equipment that may be discovered at any time prior to expiration of the warranty period shall be removed and replaced by work which shall conform to the Provisions of the Contract Documents. Any material condemned or rejected shall be removed at once from the Project site.

Failure on the part of the ENGINEER to condemn or reject bad or inferior work or to note nonconforming materials or equipment on CONTRACTOR submittals shall not be construed to imply acceptance of such work. The OWNER shall reserve and retain all of its rights and remedies at law against the CONTRACTOR and its Surety for correction of any and all latent defects discovered after the guarantee period.

**29. LINES AND GRADES**

Lines and grades shall be established as provided in the supplementary conditions. All stakes, marks, and other reference information shall be carefully preserved by the CONTRACTOR, and in case of their careless or unnecessary destruction or removal by him or his employees, such stakes, marks, and other information shall be replaced at the CONTRACTOR's expense.

**30. SUBMITTALS**

After checking and verifying all field measurements and after complying with applicable Procedures specified in Division I, GENERAL REQUIREMENTS, CONTRACTOR shall submit to ENGINEER, in accordance with the schedule for submittals for review, shop drawings, electrical diagrams, and catalog cuts for fabricated items and manufactured items (including mechanical and electrical equipment), which shall bear a stamp or specific written indication that CONTRACTOR has satisfied CONTRACTOR's responsibilities under the Contract Documents with respect to the review of the submittal. All submittals shall be identified as ENGINEER may require. The data shown shall be complete with respect to quantities, dimensions specified, performance and design criteria, materials, and similar data to enable ENGINEER to review the information. CONTRACTOR shall also submit to ENGINEER for review, with such promptness as to cause no delay in work, all samples required by the Contract Documents. All samples shall have been checked by and accompanied by a specific written indication that CONTRACTOR has satisfied CONTRACTOR's responsibilities under the Contract Documents with respect to the review of the submission and shall be identified clearly as to material, supplier, pertinent data such as catalog numbers and the use for which intended.

Before submission of each submittal, CONTRACTOR shall have determined and verified all quantities, dimensions, specified performance criteria, installation requirements, materials, catalog numbers, and similar data with respect thereto and reviewed or coordinated each submittal with other submittals and with the requirements of the work and the Contract Documents.

At the time of each submission, CONTRACTOR shall give ENGINEER specific written notice of each variation that the submittal may have from the requirements of the Contract Documents, and, in addition, shall cause a specific notation to be made on each shop drawing submitted to ENGINEER for review and approval of each variation.

**GENERAL CONDITIONS**  
**CONTENTS**

ENGINEER will review submittals with reasonable Promptness, but ENGINEER's review will be only for conformance with the design concept of the Project and for compliance with the information given in the Contract Documents and shall not extend to means, methods, techniques, sequences, or Procedures of construction (except where a specific means, method, technique, sequence, or Procedure of construction is indicated in or required by the Contract Documents) or to safety Precautions or Programs incident thereto. The review of a separate item as such will not indicate review of the assembly in which the item functions. CONTRACTOR shall make corrections required by ENGINEER, and shall return the required number of corrected copies of shop drawings and submit as required new samples for review. CONTRACTOR shall direct specific attention in writing to revisions other than the corrections called for by ENGINEER on Previous submittals.

ENGINEER's review of submittals shall not relieve CONTRACTOR from the responsibility for any variation from the requirements of the Contract Documents unless CONTRACTOR has in writing called ENGINEER's attention to each such variation at the time of submission and ENGINEER has given written approval of each such variation by a specific written notation thereof incorporated therein or accompanying the shop drawing or sample approval; nor will any approval by ENGINEER relieve CONTRACTOR from responsibility for errors or omissions in the shop drawings or from responsibility for having complied with the Provisions herein. Where a shop drawing or sample is required by the specifications, any related work performed prior to ENGINEER's review and approval of the pertinent submission shall be at the sole expense and responsibility of the CONTRACTOR.

**31. DETAIL DRAWINGS AND INSTRUCTIONS**

The ENGINEER will furnish, with reasonable Promptness, additional instructions by means of Drawings or otherwise, if, in the ENGINEER's opinion, such are required for the Proper execution of the work. All such Drawings and instructions will be consistent with the Contract Documents, true developments thereof, and reasonably inferable there from.

**THE CONTRACTOR AND HIS EMPLOYEES**

**32. CONTRACTOR, AN INDEPENDENT AGENT**

The CONTRACTOR shall independently perform all work under this Contract and shall not be considered as an agent of the OWNER or of the ENGINEER, nor shall the CONTRACTOR's SUBCONTRACTORS or employees be subagents of the OWNER or of the ENGINEER.

**33. SUBCONTRACTING**

Unless modified in the Supplementary Conditions, within 10 days after the execution of the Contract, the CONTRACTOR shall submit to the ENGINEER the names of all SUBCONTRACTORS Proposed for the work, including the names of any SUBCONTRACTORS that were submitted with the Bid. The CONTRACTOR shall not employ any SUBCONTRACTORS to which the OWNER may object to as lacking capability to properly perform work of the type and scope anticipated.

The CONTRACTOR is as fully responsible to the OWNER for the acts and omissions of his SUBCONTRACTORS and of persons either directly or indirectly employed by them as he is for the acts and omissions of persons directly employed by him.

Nothing contained in the Contract Documents shall create any contractual relationship between any SUBCONTRACTOR and the OWNER or ENGINEER.

**34. INSURANCE AND LIABILITY**

**A. GENERAL**

The CONTRACTOR shall provide (from insurance companies acceptable to the OWNER) the insurance coverage designated hereinafter and pay all costs before commencing work under this Contract. The CONTRACTOR shall furnish the OWNER with certificates of insurance specified herein showing the type, amount class of operations covered, effective dates, and date of expiration of policies, and containing substantially the following statement:

"The insurance covered by this certificate shall not be canceled or materially altered, except after 30 days' written notice has been received by the OWNER."

In case of the breach of any Provision of this Article, the OWNER, at his option, may take out and maintain, at the expense of the

GENERAL CONDITIONS  
CONTENTS

CONTRACTOR, such insurance as the OWNER may deem Proper and may deduct the cost of such insurance from any monies which may be due or become due the CONTRACTOR under this Contract.

**B. CONTRACTOR AND SUBCONTRACTOR INSURANCE**

The CONTRACTOR shall not commence work under this Contract until he has obtained all the insurance required hereunder and such insurance has been reviewed by the OWNER, nor shall the CONTRACTOR allow any SUBCONTRACTOR to commence work on his subcontract until insurance specified below has been obtained. Review of the insurance by the OWNER shall not relieve or decrease the liability of the CONTRACTOR hereunder.

**C. COMPENSATION AND EMPLOYER'S LIABILITY INSURANCE**

The CONTRACTOR shall maintain during the life of this Contract the statutory amount of Workmen's Compensation Insurance, in addition, Employer's Liability Insurance in an amount as specified in the Supplementary Conditions, for each occurrence, for all of his employees to be engaged in work on the Project under this Contract. In case any such work is subcontracted, the CONTRACTOR shall require the SUBCONTRACTOR to provide similar Workmen's Compensation and Employer's Liability Insurance for all of the SUBCONTRACTOR's employees to be engaged in such work.

**D. GENERAL LIABILITY INSURANCE (INCLUDING AUTOMOBILE)**

The CONTRACTOR shall maintain during the life of this Contract such general liability, completed operations and Products liability, and automobile liability insurance as will Provide coverage for claims for damages for personal injury, including accidental death, as well as for claims for Property damage, which may arise directly or indirectly from performance of the work under this Contract. The general liability policy shall include contractual liability assumed by the CONTRACTOR under Article **INDEMNITY**. Coverage for Property damage shall be on a "broad form" basis with no exclusions for "X, C & U". The amount of insurance to be provided shall be as specified in the Supplementary Conditions.

In the event any work under this Contract is performed by a SUBCONTRACTOR, the CONTRACTOR shall be responsible for any liability directly or indirectly arising out of the work performed by the SUBCONTRACTOR; to the extent such liability is not covered by the SUBCONTRACTOR's insurance.

The OWNER and ENGINEER, their officers, agents, and employees shall be named as Additional Insured's on the CONTRACTOR's and any SUBCONTRACTOR's general liability and automobile liability insurance policies for any claims arising out of work performed under this Contract.

**E. BUILDERS RISK ALL RISK INSURANCE**

Unless otherwise modified in the Supplementary Conditions, the CONTRACTOR shall secure and maintain during the life of this Contract, Builders Risk All Risk Insurance coverage in an amount equal to the full value of the facilities under construction. Such insurance shall include coverage for earthquake, landslide, flood, collapse, loss due to the results of faulty workmanship or design, and all other normally covered risks, and shall provide for losses to be paid to the CONTRACTOR, OWNER, and ENGINEER as their interests may appear.

The OWNER and ENGINEER, their officers, agents, and employees shall be named as additional insured's on the CONTRACTOR's and any SUBCONTRACTOR's Builders Risk All Risk insurance policies for any claims arising out of work performed under this Contract.

This insurance shall include a waiver of subrogation as to the ENGINEER, the OWNER, the CONTRACTOR, and their respective officers, agents, employees and SUBCONTRACTORS.

**F. NO PERSONAL LIABILITY OF PUBLIC OFFICIALS**

In carrying out any of the Provisions hereof in exercising any authority granted by the Contract, there will be no personal liability upon any public official.



**35. INDEMNITY**

To the maximum extent permitted by law, the CONTRACTOR shall indemnify and defend the OWNER and the ENGINEER, and their officers, employees, agents, and sub-consultants, from all claims and losses, including attorney's fees and litigation costs arising out of Property losses or health, safety, personal injury, or death claims by the CONTRACTOR, its SUBCONTRACTORS of any tier, and their employees, agents, or invitees regardless of the fault, breach of Contract, or negligence of the OWNER or ENGINEER, excepting only such claims or losses that have been adjudicated to have been caused solely by the negligence of the OWNER or the ENGINEER and regardless of whether or not the CONTRACTOR is or can be named a party in a litigation.

**36. EXCLUSION OF CONTRACTOR CLAIMS**

In performing its obligations, the ENGINEER and its consultants may cause expense for the CONTRACTOR or its SUBCONTRACTORS and equipment or material suppliers. However, those parties and their sureties shall maintain no direct action against the ENGINEER, its officers, employees, agents, and consultants for any claim arising out of, in connection with, or resulting from the engineering services performed or required to be performed.

**37. TAXES AND CHARGES**

The CONTRACTOR shall withhold and pay any and all sales and use taxes and all withholding taxes, whether State or Federal, and pay all Social Security charges and also all State Unemployment Compensation charges, and pay or cause to be withheld, as the case may be, any and all taxes, charges, or fees or sums whatsoever, which are now or may hereafter be required to be paid or withheld under any laws.

**38. REQUIREMENTS OF STATE LAW FOR PUBLIC WORKS PROJECTS**

When the Contract Documents concern public works of the state or any county, municipality, or political subdivision created by its laws, the applicable statutes shall apply. All parties to this Contract shall determine the contents of all applicable statutes and comply with their Provisions throughout the performance of the Contract.

**39. CODES, ORDINANCES, PERMITS AND LICENSES**

The CONTRACTOR shall keep himself fully informed of all local codes and ordinances, as well as state and federal laws, which in any manner affect the work herein specified. The CONTRACTOR shall at all times comply with said codes and ordinances, laws, and regulations, and Protect and indemnify the OWNER, the ENGINEER and their respective employees, and its officers and agents against any claim or liability arising from or based on the violation of any such laws, ordinances, or regulations. All permits, licenses and inspection fees necessary for Prosecution and completion of the work shall be secured and paid for by the CONTRACTOR, unless otherwise specified.

**40. SUPERINTENDENCE**

The CONTRACTOR shall keep at the project site, competent supervisory personnel. The CONTRACTOR shall designate, in writing, before starting work, a Project superintendent who shall be an employee of the CONTRACTOR and shall have complete authority to represent and to act for the CONTRACTOR. ENGINEER shall be notified in writing prior to any change in superintendent assignment. The CONTRACTOR shall give efficient supervision to the work, using his best skill and attention. The CONTRACTOR shall be solely responsible for all construction means, methods, techniques, and Procedures, and for providing adequate safety Precautions and coordinating all portions of the work under the Contract. It is specifically understood and agreed that the ENGINEER, its employees and agents, shall not have control or charge of and shall not be responsible for the construction means, methods, techniques, procedures, or for providing adequate safety precautions in connection with the work under Contract.

**41. RECEPTION OF ENGINEER'S COMMUNICATIONS**

The superintendent shall receive for the CONTRACTOR all communications from the ENGINEER. Communications of major importance will be confirmed in writing upon request from the CONTRACTOR.

The ENGINEER may schedule Project meetings for the purposes of discussing and resolving matters concerning the various

**GENERAL CONDITIONS**  
**CONTENTS**

elements of the work. Time and place for these meetings and the names of persons required to be Present shall be as determined by the ENGINEER. CONTRACTOR shall comply with these attendance requirements and shall also require his SUBCONTRACTORS to comply.

**42. SAFETY**

The CONTRACTOR shall be solely and completely responsible for conditions of the jobsite, including safety of all persons (including employees) and Property during performance of the work. This requirement shall apply continuously and not be limited to normal working hours. Safety Provisions shall conform to U.S. Department of Labor (OSHA), and all other applicable federal, state, county, and local laws, ordinances, codes, and regulations. Where any of these are in conflict, the more stringent requirement shall be followed. The CONTRACTOR's failure to thoroughly familiarize himself with the aforementioned safety Provisions shall not relieve him from compliance with the obligations and penalties set forth therein.

The CONTRACTOR shall develop and maintain for the duration of this Contract, a safety Program that will effectively incorporate and implement all required safety Provisions. The CONTRACTOR shall appoint an employee who is qualified and authorized to supervise and enforce compliance with the safety Program. The duty of the ENGINEER to conduct construction review of the work does not include review or approval of the adequacy of the CONTRACTOR's safety Program, safety supervisor, or any safety measures taken in, on, or near the construction site. The CONTRACTOR, as a part of his safety Program, shall maintain at his office or other well-known place at the jobsite, safety equipment applicable to the work as Prescribed by the aforementioned authorities, all articles necessary for giving first-aid to the injured, and shall establish the Procedure for the immediate removal to a hospital or a doctor's care of persons (including employees) who may be injured on the jobsite.

If death or serious injuries or serious damages are caused, the accident shall be reported immediately by telephone or messenger to both the ENGINEER and the OWNER. In addition, the CONTRACTOR must promptly report in writing to the ENGINEER all accidents whatsoever arising out of, or in connection with, the performance of the work whether on, or adjacent to, the site, giving full details and statements of witnesses.

If a claim is made by anyone against the CONTRACTOR or any SUBCONTRACTOR on account of any accident, the CONTRACTOR shall promptly report the facts in writing to the ENGINEER, giving full details of the claim.

**43. PROTECTION OF WORK AND PROPERTY**

The CONTRACTOR shall at all times safely guard and Protect from damage the OWNER's Property, adjacent Property, and his own work from injury or loss in connection with this Contract. All facilities required for Protection by federal, state, or municipal laws and regulations and local conditions must be provided and maintained. The CONTRACTOR shall Protect his work and materials from damage due to the nature of the work, the elements, carelessness of other CONTRACTORS, or from any cause whatever until the completion and acceptance of the work. All loss or damages arising out of the nature of the work to be done under these Contract Documents, or from any unforeseen obstruction or defects which may be encountered in the Prosecution of the work, or from the action of the elements, shall be sustained by the CONTRACTOR.

**44. RESPONSIBILITY OF CONTRACTOR TO ACT IN AN EMERGENCY**

In case of an emergency which threatens loss or injury of Property, and/or safety of life, the CONTRACTOR shall act, without previous instructions from the OWNER or ENGINEER, as the situation may warrant. The CONTRACTOR shall notify the ENGINEER thereof immediately thereafter. Any claim for compensation by the CONTRACTOR, together with substantiating documents in regard to expense, shall be submitted to the OWNER through the ENGINEER and the amount of compensation shall be determined by agreement.

**45. MATERIALS AND APPLIANCES**

Unless otherwise stipulated, the CONTRACTOR shall Provide and pay for all materials, labor, water, tools, equipment, heat, light, fuel, power, transportation, construction equipment and machinery, appliances, telephone, sanitary facilities, temporary facilities and other facilities and incidentals necessary for the execution and completion of the work.

Unless otherwise specified, all materials shall be new, and both workmanship and materials shall be of good quality. The CONTRACTOR shall, if required, furnish satisfactory evidence as to the kind and quality of materials.

GENERAL CONDITIONS  
CONTENTS

In selecting and/or approving equipment for installation in the Project, the OWNER and ENGINEER assume no responsibility for injury or claims resulting from failure of the equipment to comply with applicable federal, state, and local safety codes or requirements, or the safety requirements of a recognized agency, or failure due to faulty design concepts, or defective workmanship and materials.

**46. CONTRACTORS' AND MANUFACTURERS' COMPLIANCE WITH STATE SAFETY, OSHA, AND OTHER CODE REQUIREMENTS**

The completed work shall include all necessary permanent safety devices, such as machinery guards and similar ordinary safety items required by the state and federal (OSHA) industrial authorities and applicable local and national codes. Further, any features of the work subject to such safety regulations shall be fabricated, furnished, and installed (including OWNER-furnished equipment) in compliance with these requirements. CONTRACTORS and manufacturers of equipment shall be held responsible for compliance with the requirements included herein. CONTRACTORS shall notify all equipment suppliers and SUBCONTRACTORS of the Provisions of this Article.

**47. SUBSTITUTION OF MATERIALS**

Except for OWNER-selected equipment items, and items where no substitution is clearly specified, whenever any material, article, device, Product, fixture, form, type of construction, or Process is indicated or specified by patent or Proprietary name, by name of manufacturer, or by catalog number, such specifications shall be deemed to be used for the purpose of establishing a standard of quality and facilitating the description of the material or Process desired. This Procedure is not to be construed as eliminating from competition other Products of equal or better quality by other manufacturers where fully suitable in design, and shall be deemed to be followed by the words "or equal". The CONTRACTOR may, in such cases, submit complete data to the ENGINEER for consideration of another material, type, or Process that shall be substantially equal in every respect to that so indicated or specified. Substitute materials shall not be used unless approved in writing. The ENGINEER will be the sole judge of the substituted article or material.

**48. TESTS, SAMPLES, AND OBSERVATIONS**

The CONTRACTOR shall furnish, without extra charge, the necessary test pieces and samples, including facilities and labor for obtaining the same, as requested by the ENGINEER. When required, the CONTRACTOR shall furnish certificates of tests of materials and equipment made at the point of manufacture by a recognized testing laboratory.

The OWNER, ENGINEER, and authorized government agents, and their representatives shall at all times be Provided safe access to the work wherever it is in Preparation or Progress, and the CONTRACTOR shall Provide facilities for such access and for observations, including maintenance of temporary and permanent access.

If the Specifications, laws, ordinances, or any public authority require any work, to be specially tested or approved, the CONTRACTOR shall give timely notice of its readiness for observations. If any work should be covered up without approval or consent of the ENGINEER, it shall, if required by the ENGINEER, be uncovered for examination at the CONTRACTOR's expense. Reexamination of questioned work may be ordered by the ENGINEER, and, if so ordered, the work shall be uncovered by the CONTRACTOR. If such work is found to be in accordance with the Contract Documents, the OWNER will pay the cost of uncovering, exposure, observation, inspection, testing and reconstruction. If such work is found to be not in accordance with the Contract Documents, the CONTRACTOR shall correct the defective work, and the cost of reexamination and correction of the defective work shall be paid by the CONTRACTOR.

**49. ROYALTIES AND PATENTS**

The CONTRACTOR shall pay all royalty and licenses fees, unless otherwise specified. The CONTRACTOR shall defend all suits or claims for infringement of any patent rights and shall save the OWNER and the ENGINEER harmless from any and all loss, including reasonable attorneys' fees, on account thereof.

**50. CONTRACTOR'S RIGHT TO TERMINATE CONTRACT**

If the work should be stopped under an order of any court or other public authority for a period of more than 3 months, through no act or fault of the CONTRACTOR, its SUBCONTRACTORS, or respective employees or if the ENGINEER should fail to make recommendation for payment to the OWNER or return payment request to CONTRACTOR for revision within 30 days after it is due, or if the OWNER should fail to pay the CONTRACTOR within 30 days after time specified in Article PARTIAL PAYMENTS, any sum recommended by the ENGINEER, then the CONTRACTOR may, upon 15 days' written notice to the OWNER and the ENGINEER, stop work or terminate this Contract and recover from the OWNER payment for all acceptable work performed and reasonable termination expenses, unless said default has been remedied.

**51. CORRECTION OF DEFECTIVE WORK DURING WARRANTY PERIOD**

The CONTRACTOR hereby agrees to make, at his own expense, all repairs or replacements necessitated by defects in materials or workmanship, Provided under terms of this Contract, and pay for any damage to other works resulting from such defects, which become evident within 2 years after the date of final acceptance of the work or within 2 years after the date of substantial completion established by the ENGINEER for specified items of equipment, or within such longer period as may be Prescribed by law or by the terms of any applicable special guarantee required by the Contract Documents. Un-remedied defects identified for correction during the warranty period but remaining after its expiration shall be considered as part of the obligations of the warranty. Defects in material, workmanship, or equipment which are remedied as a result of obligations of the warranty shall subject the remedied portion of the work to an extended warranty period of 2 years after the defect has been remedied.

The CONTRACTOR further assumes responsibility for a similar guarantee for all work and materials provided by SUBCONTRACTORS or manufacturers of packaged equipment components. The effective date for the start of the guarantee or warranty period for equipment qualifying as substantially complete is defined in Article SUBSTANTIAL COMPLETION, AND Article SUBSTANTIAL COMPLETION DATE, in these General Conditions.

The CONTRACTOR also agrees to hold the OWNER and the ENGINEER harmless from liability of any kind arising from damage due to said defects. The CONTRACTOR shall make all repairs and replacements promptly upon receipt of written order for same from the OWNER. If the CONTRACTOR fails to make the repairs and replacements promptly, or in an emergency where delay would cause serious risk, or loss, or damage, the OWNER may have the defective work corrected or the rejected work removed and replaced, and the CONTRACTOR and his Surety shall be liable for the cost thereof.

**PROGRESS OF THE WORK**

**52. BEGINNING OF THE WORK**

Following execution of the Contract, the CONTRACTOR shall meet with the OWNER and ENGINEER relative to his arrangements for prosecuting the work.

**53. SCHEDULES AND PROGRESS REPORTS**

Prior to starting the construction, the CONTRACTOR shall Prepare and submit to the ENGINEER, a Progress schedule showing the dates on which each part or division of the work is expected to be started and finished, and a Preliminary schedule for submittals. The Progress schedule for submittals shall be brought up to date and submitted to the ENGINEER at the end of each month or at such other times the ENGINEER may request.

The CONTRACTOR shall forward to the ENGINEER, at the end of each month, an itemized report of the delivery status of major and critical items of purchased equipment and material, including shop drawings and the status of shop and field fabricated work. These Progress reports shall indicate the date of the purchase order, the current percentage of completion, estimated delivery, and cause of delay, if any.

If the completion of any part of the work or the delivery of materials is behind the submitted Progress schedule, the CONTRACTOR shall submit in writing a plan acceptable to the OWNER and ENGINEER for bringing the work up to schedule.

The OWNER shall have the right to withhold Progress payments for the work if the CONTRACTOR fails to update and submit the

Progress schedule and reports as specified.

**54. PROSECUTION OF THE WORK**

It is expressly understood and agreed that the time of beginning, rate of Progress, and time of completion of the work are the essence of this Contract. The work shall be prosecuted at such time, and in or on such part or parts of the Project as may be required, to complete the Project as contemplated in the Contract Documents and the Progress schedule.

If the CONTRACTOR desires to carry on work at night or outside the regular hours, he shall give timely notice to the ENGINEER to allow satisfactory arrangements to be made for observing the work in Progress.

**55. OWNER'S RIGHT TO RETAIN IMPERFECT WORK**

If any part or portion of the work completed under this Contract shall Prove defective and not in accordance with the Drawings and Specifications, and if the imperfection in the same shall not be of sufficient magnitude or importance as to make the work dangerous or unsuitable, or if the removal of such work will create conditions which are dangerous or undesirable, the OWNER shall have the right and authority to retain such work but will make such deductions in the final payment therefore as may be just and reasonable.

**56. OWNER'S RIGHT TO DO WORK**

Should the CONTRACTOR neglect to Prosecute the work in conformance with the Contract Documents or neglect or refuse at his own cost to remove and replace work rejected by the ENGINEER, then the OWNER may notify the Surety of the condition, and after 10 days' written notice to the CONTRACTOR and the Surety, or without notice if an emergency or danger to the work or public exists, and without Prejudice to any other right which the OWNER may have under Contract, or otherwise, take over that portion of the work which has been improperly or non-timely executed, and make good the deficiencies and deduct the cost thereof from the payments then or thereafter due the CONTRACTOR.

**57. OWNER'S RIGHT TO TRANSFER EMPLOYMENT**

If the CONTRACTOR should abandon the work or if he should persistently or repeatedly refuse or should fail to make prompt payment to SUBCONTRACTORS for material or labor, or to persistently disregard laws, ordinances, or to prosecute the work in conformance with the Contract Documents, or otherwise be guilty of a substantial violation of any Provision of the Contract or any laws or ordinance, then the OWNER may, without Prejudice to any other right or remedy, and after giving the CONTRACTOR and Surety 10 days' written notice, transfer the employment for said work from the CONTRACTOR to the Surety. Upon receipt of such notice, such Surety shall enter upon the Premises and take possession of all materials, tools, and appliances thereon for the purpose of completing the work included under this contract and employ by Contract or otherwise, any qualified person or persons to finish the work and Provide the materials therefore, in accordance with the Contract Documents, without termination of the continuing full force and effect of this contract. In case of such transfer of employment to such Surety, the Surety shall be paid in its own name on estimates according to the terms hereof without any right of the CONTRACTOR to make any claim for the same or any part thereof.

If, after the furnishing of said written notice to the Surety, the CONTRACTOR and the Surety still fail to make reasonable Progress on the performance of the work, the OWNER may terminate the employment of the CONTRACTOR and take possession of the Premises and of all materials, tools, and appliances thereon and finish the work by whatever method he may deem expedient and charge the cost thereof to the CONTRACTOR and the Surety. In such case, the CONTRACTOR shall not be entitled to receive any further payment until the work is finished. If the expense of completing the Contract, including compensation for additional managerial and administrative services, shall exceed such unpaid balance, the CONTRACTOR and the Surety shall pay the difference to the OWNER.

**58. DELAYS AND EXTENSION OF TIME**

If the CONTRACTOR is delayed in the Progress of the work by any act or neglect of the OWNER or the ENGINEER, or by any separate CONTRACTOR employed by the OWNER, or by strikes, lockouts, fire, adverse weather conditions not reasonably anticipated, or acts of Nature, and if the CONTRACTOR, within 48 hours of the start of the occurrence, gives written notice to the OWNER of the cause of the potential delay and estimate of the possible time extension involved, and within 10 days after the cause



GENERAL CONDITIONS  
CONTENTS

of the delay has been remedied, the CONTRACTOR gives written notice to the OWNER of any actual time extension requested as a result of the aforementioned occurrence, then the Contract time may be extended by change order for such reasonable time as the ENGINEER determines. It is agreed that no claim shall be made or allowed for any damages, loss, or expense which may arise out of any delay caused by the above referenced acts or occurrences other than claims for the appropriate extension of time. No extension of time will be granted to the CONTRACTOR for delays occurring to parts of the work that have no measurable impact on the completion of the total work under this Contract. No extension of time will be considered for weather conditions reasonably anticipated for the area in which the work is being performed. Reasonably anticipated weather conditions will be based on official records of monthly Precipitation and other historical data. Adverse weather conditions, if determined to be of a severity that would impact Progress of the work, may be considered as cause for an extension of Contract completion time.

Delays in delivery of equipment or material purchased by the CONTRACTOR or his SUBCONTRACTORS, including OWNER-selected equipment shall not be considered as a just cause for delay, unless the OWNER determines that for good cause the delay is beyond the control of the CONTRACTOR. The CONTRACTOR shall be fully responsible for the timely ordering, scheduling, complete the work is the per-diem rate, as stipulated in the Bid. The said amount is hereby agreed upon as a reasonable estimate of the costs, which may be accrued by the OWNER after the expiration of the time of completion. It is expressly understood and agreed that this amount is not to be considered in the nature of a penalty, but as liquidated damages which have accrued against the CONTRACTOR. The OWNER shall have the right to deduct such damages from any amount due, or that may become due the CONTRACTOR, or the amount of such damages shall be due and collectible from the CONTRACTOR or Surety.

**59. DIFFERING SITE CONDITIONS**

The CONTRACTOR shall promptly, and before the conditions are disturbed, give a written notice to the OWNER and ENGINEER of:

- A. subsurface or latent physical conditions at the site which differ materially from those indicated in this contract,
- B. unknown physical conditions at the site, of an unusual nature, which differ materially from those ordinarily encountered and generally recognized as inherent in work of the character provided for in the Contract.

The ENGINEER will investigate the site conditions promptly after receiving the notice. If the conditions do materially so differ and cause an increase or decrease in the CONTRACTOR's cost of, or the time required for, performing any part of the work under this Contract, whether or not changed as a result of the conditions, and equitable adjustment shall be made under this Article and the Contract modified in writing accordingly.

No request by the CONTRACTOR for an equitable adjustment to the Contract under this Article will be allowed, unless the CONTRACTOR has given the written notice required; provided that the time prescribed above for giving written notice may be extended by the OWNER.

No request by the CONTRACTOR for an equitable adjustment to the Contract for differing site conditions will be allowed if made after final payment under this Contract.

**60. LIQUIDATED DAMAGES**

Should the CONTRACTOR fail to complete the work, or any part thereof, in the time agreed upon in the Contract or within such extra time as may have been allowed for delays by extensions granted as Provided in the Contract, the CONTRACTOR shall reimburse the OWNER for the additional expense and damage for each calendar day, Sundays and legal holidays included, that the Contract remains uncompleted after the Contract completion date. It is agreed that the amount of such additional expense and damage incurred by reason of failure to complete the work is the per-diem rate, as stipulated in the Bid. The said amount is hereby agreed upon as a reasonable estimate of the costs which may be accrued by the OWNER after the expiration of the time of completion. It is expressly understood and agreed that this amount is not to be considered in the nature of a penalty, but as liquidated damages which have accrued against the CONTRACTOR. The OWNER shall have the right to deduct such damages from any amount due, or that may become due the CONTRACTOR, or the amount of such damages shall be due and collectible from the CONTRACTOR or Surety.

**61. OTHER CONTRACTS**

The OWNER reserves the right to let other Contracts in connection with the work. The CONTRACTOR shall afford other

GENERAL CONDITIONS  
CONTENTS

CONTRACTORS reasonable opportunity for the introduction and storage of their materials and the execution of their work and shall properly connect and coordinate his work with theirs.

If any part of the work under this Contract depends for Proper execution or results upon the work of any other CONTRACTOR, utility service company or OWNER, the CONTRACTOR shall inspect and Promptly report to the ENGINEER in writing any patent or apparent defects to deficiencies in such work that render it unsuitable for such Proper execution and results. The CONTRACTOR's failure to so report shall constitute and acceptance of the work by others as being fit and Proper for integration with work under this Contract, except for latent or non-apparent defects and deficiencies in the work.

**62. USE OF PREMISES**

The CONTRACTOR shall confine his equipment, the storage of materials and the operation of his workers to limits shown on the Drawings or indicated by law, ordinances, permits, or directions of the ENGINEER, and shall not unreasonably encumber the Premises with his materials. The CONTRACTOR shall provide, at his own expense, the necessary rights-of-way and access to the work, which may be required outside the limits of the OWNER's Property and shall furnish the ENGINEER copies of permits and agreements for use of the Property outside that provided by the OWNER.

The CONTRACTOR shall not load nor permit any part of the structure to be loaded in any manner that will endanger the structure, nor shall CONTRACTOR subject any part of the work or adjacent Property to stresses or Pressures that will endanger it.

**63. SUBSTANTIAL COMPLETION DATE**

The ENGINEER may issue a written notice of substantial completion for the purpose of establishing the starting date for specific equipment guarantees, and to establish the date that the OWNER will assume the responsibility for the cost of operating such equipment. Said notice shall not be considered as final acceptance of any portion of the work or relieve the CONTRACTOR from completing the remaining work within the specified time and in full compliance with the Contract Documents. See SUBSTANTIAL COMPLETION under DEFINITIONS of these General Conditions.

**64. PERFORMANCE TESTING**

Operating equipment and systems shall be performance tested in the Presence of the ENGINEER to demonstrate compliance with the specified requirements. Performance testing shall be conducted under the specified design operating conditions or under such simulated operating conditions as recommended or approved by the ENGINEER. Schedule such testing with the ENGINEER at least one week in advance of the planned date for testing.

**65. OWNER'S USE OF PORTIONS OF THE WORK**

Following issuance of the written notice of Substantial Completion, the OWNER may initiate operation of the facility. Such use shall not be considered as final acceptance of any portion of the work, nor shall such use be considered as cause for an extension of the Contract completion time, unless authorized by a Change Order issued by the OWNER.

**66. CUTTING AND PATCHING**

The CONTRACTOR shall do all cutting, fitting, or patching of his work that may be required to make its several parts come together Properly and fit it to receive or be received by work of other CONTRACTORS shown upon or reasonably implied by the Drawings.

**67. CLEANING UP**

The CONTRACTOR shall, at all times, keep Property on which work is in Progress and the adjacent Property free from accumulations of waste material or rubbish caused by employees or by the work. Upon completion of the construction, the CONTRACTOR shall remove all temporary structures, rubbish, and waste materials resulting from his operations.

**PAYMENT**

**68. PAYMENT FOR CHANGE ORDERS**

**GENERAL CONDITIONS**  
**CONTENTS**

The OWNER's request for quotations on alterations to the work shall not be considered authorization to proceed with the work expediting, delivery, and installation of all equipment and materials. Within a reasonable period after the CONTRACTOR submits to the OWNER a written request for an extension of time, the ENGINEER will Present his written opinion to the OWNER as to whether an extension of time is justified, and, if so, his recommendation as to the number of days for time extension. The OWNER will make the final decision on all requests for extension of time.

Prior to the issuance of a formal Change Order, nor shall such request justify any delay in existing work. Quotations for alterations to the work shall include substantiating documentation with an itemized breakdown of CONTRACTOR and SUBCONTRACTOR costs, including labor, material, rentals, approved services, overhead, and profit. OWNER may require detailed cost data in order to substantiate the reasonableness of the proposed costs.

Any compensation paid in conjunction with the terms of a Change Order shall comprise total compensation due the CONTRACTOR for the work or alteration defined in the Change Order. By signing the Change Order, the CONTRACTOR acknowledges that the stipulated compensation includes payment for the work or alteration plus all payment for the interruption of schedules, extended overhead, delay, or any other impact claim or ripple effect, and by such signing specifically waives any reservation or claim for additional compensation in respect to the subject Change Order.

At the OWNER's option, payment or credit for any alterations covered by a Change Order shall be determined by one or a combination of the methods set forth in A, B, or C below, as applicable:

**A. UNIT PRICES**

Those unit Prices stipulated in the Bid shall be utilized where they are applicable. In the event the Change Order results in a change in the original quantity that is materially and significantly different from the original bid quantity, a new unit Price shall be negotiated upon demand of either party. Unit Prices for new items included in the Change Order shall be negotiated and mutually agreed upon.

**B. LUMP SUM**

A total lump sum for the work negotiated and mutually acceptable to the CONTRACTOR and the OWNER. Lump sum quotations for modifications to the work shall include substantiating documentation with an itemized breakdown of CONTRACTOR and SUBCONTRACTOR costs, including labor, material, rentals, approved services, overhead, and Profit, all calculated as specified under "C" below.

**C. COST REIMBURSEMENT WORK**

The term "cost reimbursement" shall be understood to mean that payment for the work will be made on a time and expense basis, that is, on an accounting of the CONTRACTOR's forces, materials, equipment, and other items of cost as required and used to do the work.

If the method of payment cannot be agreed upon Prior to the beginning of the work, and the OWNER directs by written Change Order that the work be done on a cost reimbursement basis, then the CONTRACTOR shall furnish labor, and furnish and install equipment and materials necessary to complete the work in a satisfactory manner and within a reasonable period of time. For the work performed, payment will be made for the documented actual cost of the following:

1. Labor including foremen for those hours they are assigned and participating in the cost reimbursement work (actual payroll cost, including wages, fringe benefits as established by negotiated labor agreements, labor insurance, and labor taxes as established by law). No other fixed labor burdens will be considered, unless approved in writing by the OWNER.
2. Material delivered and used on the designated work, including sales tax, if paid by the CONTRACTOR or his SUBCONTRACTOR.
3. Rental or equivalent rental cost of equipment, including necessary transportation for items having a value in excess of \$100. Rental or equivalent rental cost will be allowed for only those days or hours during which the equipment is in actual use. Rental and transportation allowances shall not exceed the current rental rates prevailing in the locality. The rentals allowed for equipment will, in all cases, be understood to cover all fuel, supplies, repairs, and renewals, and no further allowances will be made for those items, unless specific agreement to that effect is made.
4. Additional bond, as required and approved by the OWNER.

**GENERAL CONDITIONS**  
**CONTENTS**

5. Additional insurance (other than labor insurance) as required and approved by the OWNER.

In addition to items 1 through 5 above, an added fixed fee for general overhead and Profit shall be negotiated and allowed for the CONTRACTOR (or approved SUBCONTRACTOR) actually executing the Cost Reimbursement work.

An additional fixed fee shall be negotiated and allowed the CONTRACTOR for the administrative handling of portions of the work that are executed by an approved SUBCONTRACTOR. No additional fixed fee will be allowed for the administrative handling of work executed by a SUBCONTRACTOR of a SUBCONTRACTOR, unless by written permission from the OWNER.

The added fixed fees shall be considered to be full compensation, covering the cost of general supervision, overhead, Profit, and any other general expense. The CONTRACTOR's records shall make clear distinction between the direct costs of work paid for on a cost reimbursement basis and the costs of other work. The CONTRACTOR shall furnish the ENGINEER report sheets in duplicate of each day's cost reimbursement work no later than the working day following the performance of said work. The daily report sheets shall itemize the materials used, and shall cover the direct cost of labor and the charges for equipment rental, whether furnished by the CONTRACTOR, SUBCONTRACTOR or other forces. The daily report sheets shall provide names or identifications and classifications of workers, the hourly rate of pay and hours worked, and also the size, type, and identification number of equipment and hours operated.

Material charges shall be substantiated by valid copies of vendors' invoices. Such invoices shall be submitted with the daily report sheets, or, if not available, they shall be submitted with subsequent daily report sheets. Said daily report sheets shall be signed by the CONTRACTOR or his authorized agent.

The OWNER reserves the right to furnish such materials and equipment as he deems expedient and the CONTRACTOR shall have no claim for profit or added fees on the cost of such materials and equipment. To receive partial payments and final payment for cost reimbursement work, the CONTRACTOR shall submit to the ENGINEER, detailed and complete documented verification of the CONTRACTOR's and any of his SUBCONTRACTORS' actual costs involved in the cost reimbursement work. Such costs shall be submitted within 30 days after said work has been performed.

**69. PARTIAL PAYMENTS**

**A. GENERAL**

Nothing in this Article shall be construed to affect the right, hereby reserved, to reject the whole or any part of the aforesaid work, should such work be later found not to comply with the Provisions of the Contract Documents. All estimated quantities of work for which partial payments have been made are subject to review and correction on the final estimate. Payment by the OWNER and acceptance by the CONTRACTOR of partial payments based on periodic estimates of quantities of work performed shall not, in any way, constitute acceptance of the estimated quantities used as a basis for computing the amounts of the partial payments.

**B. ESTIMATE**

At least 30 days before each Progress payment falls due, as specified in the Supplementary Conditions, the CONTRACTOR shall submit to the ENGINEER a detailed estimate of the amount earned during the Preceding month for the separate portions of the work, and request payment. As used in this Article, the words "amount earned" means the value, on the date of the estimate for partial payment, of the work completed in accordance with the Contract Documents, and the value of approved materials delivered to the Project site suitable stored and Protected Prior to incorporation into the work.

ENGINEER will, within 7 days after receipt of each request for payment, either indicate in writing a recommendation of payment and present the request to OWNER, or return the request to CONTRACTOR indicating in writing ENGINEER's reasons for refusing to recommend payment. In the latter case, CONTRACTOR may, within 7 days, make the necessary corrections and resubmit the request.

ENGINEER may refuse to recommend the whole or any part of any payment if, in his opinion, it would be incorrect to make such representations to OWNER. ENGINEER may also refuse to recommend any such payment, or, because of subsequently discovered evidence or the results of subsequent inspections or tests, nullify any such payment previously recommended to such an extent as may be necessary in ENGINEER's opinion to protect the OWNER from loss because:

**GENERAL CONDITIONS**  
**CONTENTS**

1. The work is defective, or completed work has been damaged requiring correction or replacement;
2. Written claims have been made against OWNER or Liens have been filed in connection with the work;
3. The Contract Price has been reduced because of Change Orders;
4. OWNER has been required to correct defective work or complete the work in accordance with Article OWNER'S RIGHT TO DO WORK;
5. Of CONTRACTOR's unsatisfactory Prosecution of the work in accordance with the Contract Documents; or
6. CONTRACTOR's failure to make payment to SUBCONTRACTORS or for labor, materials, or equipment.

**C. DEDUCTION FROM ESTIMATE**

Unless modified in the Supplementary Conditions, deductions from the estimate will be as described below:

1. The OWNER will deduct from the estimate, and retain as part security, 10 percent of the amount earned for work satisfactorily completed. A deduction and retainage of 10 percent will be made on the estimated amount earned for approved items of material delivered to and properly stored at the jobsite but not incorporated into the work. When the work is 50 percent complete, the OWNER may reduce the retainage to 5 percent of the dollar value of all work satisfactorily completed to date provided the CONTRACTOR is making satisfactory progress and there is no specific cause for a greater retainage. The OWNER may reinstate the retainage up to 10 percent if the OWNER determines, at his discretion, that the CONTRACTOR is not making satisfactory progress or where there is other specific cause for such withholding.

**D. QUALIFICATION FOR PARTIAL PAYMENT FOR MATERIALS DELIVERED**

Unless modified in the Supplementary Conditions, qualification for partial payment for materials delivered but not yet incorporated into the work shall be as described below:

1. Materials, as used herein, shall be considered to be those items which are fabricated and manufactured material and equipment. No consideration shall be given to individual purchases of less than \$200 for any one item.
2. To receive partial payment for materials delivered to the site, but not incorporated in the work, it shall be necessary for the CONTRACTOR to include a list of such materials on the Partial Payment Request. At his sole discretion, the ENGINEER may approve items for which partial payment is to be made. Partial payment shall be based on the CONTRACTOR's actual cost for the materials as evidenced by invoices from the supplier. Proper storage and Protection shall be provided by the CONTRACTOR, and as approved by the ENGINEER. Final payment shall be made only for materials actually incorporated in the work and, upon acceptance of the work, all materials remaining for which advance payments had been made shall revert to the CONTRACTOR, unless otherwise agreed, and partial payments made for these items shall be deducted from the final payment for the work.
3. CONTRACTOR warrants and guarantees that title to all work, materials, and equipment covered by any Application for Payment, whether incorporated in the Project or not, will pass to OWNER at the time of payment free and clear of all liens, claims, security interests, and encumbrances.
4. If requested by the ENGINEER, the CONTRACTOR shall provide, with subsequent pay requests, invoices received by the supplier showing payment in full has been made.

**E. PAYMENT**

After deducting the retainage and the amount of all previous partial payments made to the CONTRACTOR from the amount earned, the amount due will be made payable to the CONTRACTOR. Recommendations for payment received by the OWNER less than 9 days Prior to the scheduled day for payment will not be Processed or paid until the following month.

**70. CLAIMS FOR EXTRA WORK**



GENERAL CONDITIONS  
CONTENTS

In any case where the CONTRACTOR deems additional time or compensation will become due him under this Contract for circumstances other than those defined in Article DELAYS AND EXTENSION OF TIME, the CONTRACTOR shall notify the ENGINEER, in writing, of his intention to make claim for such time or compensation before he begins the work on which he bases the claim, in order that such matters may be settled, if possible, or other appropriate action taken. The notice of claim shall be in duplicate, in writing, and shall state the circumstances and the reasons for the claim, but need not state the amount. If such notification is not given or if the ENGINEER is not afforded proper facilities by the CONTRACTOR for keeping strict account of actual cost, then the CONTRACTOR hereby agrees to waive the claim for such additional time or compensation. Such notice by the CONTRACTOR, and fact that the ENGINEER has kept account of the cost as aforesaid, shall not in any way be construed as proving the validity of the claim.

No extension of time will be granted to the CONTRACTOR for delays resulting from extra work that have no measurable impact on the completion of the total work under this Contract. Claims for additional time or compensation shall be made in itemized detail and submitted, in writing, to the OWNER and ENGINEER within 10 days following completion of that portion of the work for which the CONTRACTOR bases his claim. Failure to make the claim for additional compensation in the manner and within the time specified above shall constitute waiver of that claim. In case the claim is found to be just, it shall be allowed and paid for as provided in Article PAYMENT FOR CHANGE ORDERS.

**71. RELEASE OF LIENS OR CLAIMS**

The CONTRACTOR shall indemnify and hold harmless the OWNER from all claims for labor and materials furnished under this Contract. Prior to the final payment, the CONTRACTOR shall furnish to the OWNER, as part of his final payment request, a certification that all of the CONTRACTOR's obligations on the project have been satisfied and that all monetary claims and indebtedness have been paid. The CONTRACTOR shall furnish complete and legal effective releases or waivers, satisfactory to the OWNER, of all liens arising out of or filed in connection with the work.

**72. FINAL PAYMENT**

Upon completion of all the work under this Contract, the CONTRACTOR shall notify the ENGINEER, in writing, that he has completed his part of the Contract and shall request final payment. Upon receipt of such notice the ENGINEER will inspect and, if acceptable, submit to the OWNER his recommendation as to acceptance of the completed work and as to the final estimate of the amount due the CONTRACTOR. Upon approval of this final estimate by the OWNER and compliance by the CONTRACTOR with Provisions in Article **RELEASE OF LIENS OR CLAIMS**, and other Provisions as may be applicable, the OWNER shall pay to the CONTRACTOR all monies due him under the Provisions of these Contract Documents.

**73. NO WAIVER OF RIGHTS**

Neither the inspection by the OWNER, through the ENGINEER or any of his employees, nor any order by the OWNER for payment of money, nor any payment for, or acceptance of, the whole or any part of the work by the OWNER or ENGINEER, nor any extension of time, nor any possession taken by the OWNER or its employees, shall operate as a waiver of any Provision of this Contract, or any power herein reserved to the OWNER, or any right to damages herein Provided, nor shall any waiver of any breach in this Contract be held to be a waiver of any other or subsequent breach. Acceptance or final payment shall not be final and conclusive with regards to latent defects, fraud, or such gross mistakes as may amount to fraud, or as regards the OWNER's rights under the warranty.

**74. ACCEPTANCE OF FINAL PAYMENT CONSTITUTES RELEASE**

The acceptance by the CONTRACTOR of the final payment shall release the OWNER and the ENGINEER, as representatives of the OWNER, from all claims and all liability to the CONTRACTOR for all things done or furnished in connection with the work, and every act of the OWNER and others relating to or arising out of the work except claims Previously made in writing and still unsettled. No payment, however, final or otherwise, shall operate to release the CONTRACTOR or his Sureties from obligations under this Contract and other bonds and warranties, as herein provided.

**SUPPLEMENTARY CONDITIONS**

The General Conditions are hereby revised as follows:

ARTICLE 9 “ENGINEER”

Delete Article “ENGINEER” in its entirety and substitute the following:

The person or organization identified as such in the Contract Documents. The Term “ENGINEER” means authorized OWNER’s representative.

ARTICLE 32 “CONTRACTOR, AN INDEPENDENT AGENT”

Add the following:

A. ASSIGNMENT OF CONTRACT

Assignment of any part or the whole of this Contract shall be subject to review and approval of the City Commission

ARTICLE 34 "INSURANCE & LIABILITY”

Delete Articles 34 A, B, C, D & E and substitute the following:

Contractor shall maintain limits no less than those stated below:

CONTRACTOR is to secure, pay for, and file with the City of Key West, prior to commencing any work under the Contract, all certificates for workers’ compensation, public liability, and property damage liability insurance, and such other insurance coverages as may be required by specifications and addenda thereto, in at least the following minimum amounts with specification amounts to prevail if greater than minimum amounts indicated. Notwithstanding any other provision of the Contract, the CONTRACTOR shall provide the minimum limits of liability insurance coverage as follows:

Auto Liability	\$1,000,000	Combined Single Limit
General Liability	\$1,000,000	Aggregate (Per Project)
	\$2,000,000	Products Aggregate
	\$1,000,000	Any One Occurrence
	\$1,000,000	Personal Injury
	\$ 300,000	Fire Damage/Legal

CONTRACTOR shall furnish an original Certificate of Insurance indicating, and such policy providing coverage to, City of Key West named as an additional insured on a PRIMARY and NON CONTRIBUTORY basis utilizing an ISO standard endorsement at least as broad as CG 2010 (11/85) or its equivalent, (combination of CG 20 10 07 04 and CG 20 37 07 04, providing

GENERAL CONDITIONS  
CONTENTS

coverage for completed operations, is acceptable) including a waiver of subrogation clause in favor of City of Key West on all policies. CONTRACTOR will maintain the General Liability and Umbrella Liability insurance coverages summarized above with coverage continuing in full force including the additional insured endorsement until at least 3 years beyond completion and delivery of the work contracted herein.

Notwithstanding any other provision of the Contract, the CONTRACTOR shall maintain complete workers' compensation coverage for each and every employee, principal, officer, representative, or agent of the CONTRACTOR who is performing any labor, services, or material under the Contract. Further, CONTRACTOR shall additionally maintain the following minimum limits of coverage:

Bodily Injury Each Accident	\$1,000,000
Bodily Injury by Disease Each Employee	\$1,000,000
Bodily Injury by Disease Policy Limit	\$1,000,000

CONTRACTOR's insurance policies shall be endorsed to give 30 days' written notice to the City of Key West in the event of cancellation or material change, using form CG 02 24, or its equivalent.

Certificates of Insurance submitted to the City of Key West will not be accepted without copies of the endorsements being requested. This includes additional insured endorsements, cancellation/material change notice endorsements, and waivers of subrogation. PLEASE ADVISE YOUR INSURANCE AGENT ACCORDINGLY.

CONTRACTOR will comply with any and all safety regulations required by any agency or regulatory body including but not limited to OSHA. CONTRACTOR will notify City of Key West immediately by telephone at (305) 809-3811 any accident or injury to anyone that occurs on the jobsite and is related to any of the work being performed by the CONTRACTOR.

Add the following Article:

**G. SURETY AND INSURER QUALIFICATIONS**

All bonds, insurance contracts, and certificates of insurance shall be either executed by or countersigned by a licensed resident agent of the Surety or insurance company, having his place of business in the State of Florida, and in all ways complying with the insurance laws of the State of Florida. Further, the said Surety or Insurance Company shall be duly licensed and qualified to do business in the State of Florida. If requested, Contractor shall Provide Proof of Florida Licensure for all insurance companies. The City of Key West shall be named as Additional Insured on the insurance certificates.

**ARTICLE 35 "INDEMNITY"**

GENERAL CONDITIONS  
CONTENTS

Delete Article "INDEMNITY" in its entirety and substitute the following:

**INDEMNITY**

To the fullest extent permitted by law, the CONTRACTOR expressly agrees to indemnify and hold harmless the City of Key West, their officers, directors, agents, and employees (herein called the "indemnitees") from liabilities, damages, losses and costs, including, but not limited to, reasonable attorney's fees and court costs, such legal expenses to include costs incurred in establishing the indemnification and other rights agreed to in this Paragraph, to persons or property, to the extent caused by the negligence, recklessness, or intentional wrongful misconduct of the CONTRACTOR, its Subcontractors or persons employed or utilized by them in the performance of the Contract. Claims by indemnitees for indemnification shall be limited to the amount of CONTRACTOR's insurance or \$1 million per occurrence, whichever is greater. The parties acknowledge that the amount of the indemnity required hereunder bears a reasonable commercial relationship to the Contract and it is part of the project specifications or the bid documents, if any. The indemnification obligations under the Contract shall not be restricted in any way by any limitation on the amount or type of damages, compensation, or benefits payable by or for the CONTRACTOR under workers' compensation acts, disability benefits acts, or other employee benefits acts, and shall extend to and include any actions brought by or in the name of any employee of the CONTRACTOR or of any third party to whom CONTRACTOR may subcontract a part or all the Work. This indemnification shall continue beyond the date of completion of the work. Nothing contained in this paragraph is intended to nor shall it constitute a waiver of the State of Florida and the CITY's sovereign immunity.

**ARTICLE 39 "CODES, ORDINANCES, PERMITS, AND LICENSES"**

Add the following:

**A. NOISE ORDINANCE**

City of Key West has a noise ordinance that allows working hours between 8:00 AM to 7:00 PM, Monday through Friday. No work should be performed during weekends or City Holidays, State Holidays and National Holidays. Any construction operations outside these hours and these days will require a variance from the City of Key West Commission.

**B. "LICENSES"**

**THE BIDDER MUST BE A LICENSED CONTRACTOR BY THE STATE OF FLORIDA AND SUBMIT PROOF OF SUCH WITH THE BID.**

1. Within 10 days of Notice of Award, the successful Bidder must represent that he holds all applicable, county, and City of Key West licenses and permits required to do business as a contractor with respect to the work described in the Contract Documents.

GENERAL CONDITIONS  
CONTENTS

2. Further, the successful Bidder must, within 10 days of Notice of Award, furnish documentation showing that, as a minimum, he has complied with the provisions of Chapter 18 of the Code of Ordinances of the City of Key West to enter the Agreement contained in the Contract Documents.
3. Specifically, within 10 days after Notice of Award, the successful Bidder must demonstrate that he holds, as a minimum, the following licenses and certificates:
  - a.) City of Key West Tax License Receipt;
  - b.) A valid Certificate of Competency issued by the Chief Building Official of Key West, Florida
  - c.) A valid occupational license issued by the City of Key West, Florida.

ARTICLE 40 "SUPERINTENDENCE"

Add the following sub article:

The CONTRACTOR shall keep at the project site, competent supervisory personnel, able to read, write and speak English to effectively communicate with City staff.

ARTICLE 42 "SAFETY"

Add the following sub article:

OCCUPATIONAL SAFETY AND HEALTH

The Contractor shall observe and comply with all applicable local, state, and federal occupational safety and health regulations during the prosecution of work under this Contract. In addition, full compliance by the Contractor with the U.S. Department of Labor's Occupational Safety and Health Standards, as established in Public Law 91-596, will be required under the terms of this Contract.

ARTICLE 43 "PROTECTION OF WORK AND PROPERTY"

Add the following Article:

HISTORIC PRESERVATION

The Contractor shall comply with Florida's Archives and Historic Act (Florida Statutes, Chapter 267) and the regulations of the local historic preservation board as applicable and protect against the potential loss or destruction of significant historical or archaeological data, sites, and properties in connection with the project.

ARTICLE 57 "OWNERS RIGHT TO TRANSFER EMPLOYMENT"

Add the following Article:

GENERAL CONDITIONS  
CONTENTS

TERMINATION FOR CONVENIENCE AND RIGHT OF SUSPENSION

A. Owner shall have the right to terminate this Contract without cause by written notice of Termination to the Contractor. In the event of such termination for convenience, the Contractor's recovery against the Owner shall be limited to that portion of the Contract amount earned through the date of termination, together with any retainage withheld and reasonable termination expenses incurred. Contractor shall not be entitled to any other or further recovery against the Owner, including, but not limited to, damages or any anticipated profit on portions of the Work not performed.

B. The Owner shall have the right to suspend all or any portions of the Work upon giving the Contractor prior written notice of such suspension. If all or any portion of the Work is so suspended, the Contractor shall be entitled to reasonable costs, expenses and time extension associated with the suspension.

ARTICLE 60 "LIQUIDATED DAMAGES"

Delete Article "LIQUIDATED DAMAGES" in its entirety and substitute the following:  
LIQUIDATED DAMAGES

Should the Contractor fail to complete the work or any part thereof in the time agreed upon in the Contract Documents or within such extra time as may have been allowed for delays by extensions granted as provided in the Contract, the Contractor shall reimburse the Owner for the additional expense and damage for each calendar day that project outlined in Contract Documents remains uncompleted after the completion date. Liquidated damages shall be assessed. It is agreed that the amount of such additional expense and damage incurred by reason of failure to complete the work is the per diem rate as stipulated in the Bid. The said amount is hereby agreed upon as a reasonable estimate of the costs which may be accrued by the Owner after the expiration of the time of completion. It is expressly understood and agreed that this amount is not to be considered in the nature of a penalty but as liquidated damages, which have accrued against the Contractor. The Owner shall have the right to deduct such damages from any amount due or that may become due the Contractor or the amount of such damages shall be due and collectible from the Contractor.

ARTICLE 68 "PAYMENT"

Sub article C. "COST REIMBURSEMENT WORK"

Delete the third & fourth paragraph in its entirety & substitute the following;

In addition to 1 through 5 above, an added fixed fee of 15 percent (%) for general overhead & profit shall be allowed for the CONTRACTOR (or approved SUBCONTRACTOR) executing the Cost Reimbursement work.

An additional fixed fee of 5 % will be allowed the CONTRACTOR for the administrative handling of portions of the work that are executed by an approved SUBCONTRACTOR. No additional fixed fee will be allowed for the administrative handling of work executed by the SUBCONTRACTOR of a SUBCONTRACTOR.



GENERAL CONDITIONS  
CONTENTS

ARTICLE 69 "PARTIAL PAYMENTS"

Delete the first paragraph of Sub Article B. "ESTIMATE" and substitute the following:

No more than once each month the Contractor shall submit to the ENGINEER a detailed estimate of the amount earned during the preceding month for the separate portions of the work and request payment. As used in this Article the words "amount earned" means the value, on the date of the estimate, for partial payment of the work completed in accordance with the Contract Documents and the value of approved materials delivered to the project site suitably stored and protected prior to incorporation into the work. Payment will be made by the Owner to the Contractor within 40 days receipt of the written recommendation of payment from the ENGINEER.

Sub Article C. "DEDUCTION FROM ESTIMATE"

Delete third sentence in its entirety and substitute add the following;

1. When the work is 90 per cent complete, the OWNER may reduce the retainage to 5 percent of the dollar value of all work satisfactorily completed to date provided the CONTRACTOR is making satisfactory progress and there is no specific cause for greater retainage.

Delete Sub article E. "PAYMENT" in its entirety and substitute the following:

After deducting the retainage and the amount of all previous partial payments made to the Contractor from the amount earned the amount due will be made payable to the Contractor. Recommendations for payment received by the Owner less than 40 days prior to the scheduled day for payment will not be processed or paid until the following month.

ARTICLE 72 "FINAL PAYMENT"

Delete Article "FINAL PAYMENT" in its entirety and substitute the following:

FINAL PAYMENT

Upon completion of the work the Contractor shall notify the ENGINEER, in writing, that he has completed it and shall request final payment. The Contractor shall be responsible for keeping an accurate and detailed record of his actual construction. Upon completion of construction and before final acceptance and payment the Contractor shall furnish the ENGINEER as-built drawings of his construction. Upon receipt of a request for final payment and the as-built drawings the ENGINEER will inspect and, if acceptable, submit to the Owner his recommendation as to acceptance of the completed work and as to the final estimate of the amount due the Contractor. Upon approval of this final estimate by the Owner and compliance by the Contractor with provisions in Article RELEASE OF LIENS OR CLAIMS, and other provisions as may be applicable, the Owner shall pay to the Contractor all monies due him under the provisions of these Contract Documents.

GENERAL CONDITIONS  
CONTENTS

A. Acceptance and Final Payment

Whenever the Contractor has completely performed the work provided for under the Contract and the ENGINEER has performed a final inspection and made final acceptance and subject to the terms of the ENGINEER will prepare a final estimate showing the value of the work as soon as the ENGINEER makes the necessary measurements and computations. The ENGINEER will correct all prior estimates and payments in the final estimate and payment. The OWNER will pay the estimate, less any sums that the OWNER may have deducted or retained under the provisions of the Contract, as soon as practicable after final acceptance of the work, provided the Contractor has met the requirements of (1) through (4) below.

1. The Contractor has agreed in writing to accept the balance due or refund the overpayment, as determined by the OWNER, as full settlement of his account under the Contract and of all claims in connection therewith, or the Contractor, accepted the balance due or refunded the overpayment, as determined by the OWNER, with the stipulation that his acceptance of such payment or the making of such refund does not constitute any bar, admission, or estoppel, or have any effect as to those payments in dispute or the subject of a pending claim between the Contractor and the OWNER. To receive payment based on a FINAL PAYMENT CERTIFICATE, The Contractor further agrees, by submitting a FINAL PAYMENT CERTIFICATE that any pending or future arbitration claim or suit is limited to those particulars, including the itemized amounts, defined in the original FINAL PAYMENT CERTIFICATE , and that he will commence with any such arbitration claim or suit within 15 calendar days from and after the time of final PAYMENT of the work and that his failure to file a formal claim within this period constitutes his full acceptance of the ENGINEER's final estimate and payment. The overpayment refund check from the Contractor, if required, will be considered a part of any Acceptance Letter executed.
2. The Contractor has properly maintained the project, as specified hereinbefore.
3. The Contractor has furnished a sworn affidavit to the effect that the Contractor has paid all bills and no suits are pending (other than those exceptions listed, if any) in connection with work performed under the Contract and that the Contractor has not offered or made any gift or gratuity to, or made any financial transaction of any nature with, any employee of the OWNER in the performance of the Contract.
4. Final payment will not be released until the City receives Certified As-built drawings in Auto Cad & Adobe format as well as:

**As-Built Drawing Standards:**

All supplied data collections, as-builts, drawings and files to be compatible with esri ArcGIS 10.2.2 Software. The current computing environment consists of:

GENERAL CONDITIONS  
CONTENTS

- Microsoft SQL Server - Windows 7/Server 2008 - ESRI GIS Platform

Interfaces and Integrations:

The City of Key West uses a number of software applications critical to its core operation and mission. The proposed mobile asset data collection solution will need to interface or integrate with these existing platforms. - Arc Collector-ArcGIS Online - ArcMap 10.2

**END OF SECTION**

---

---

## **PART 4**

# **GENERAL REQUIREMENTS**

---

---

**SECTION 01001**  
**GENERAL REQUIREMENTS**

**PART 1 - GENERAL**

1.1 PROJECT DESCRIPTION

- A. A brief description of the work is stated in the Invitation to Bid. To determine the full scope of the project or of any part of the project, coordinate the applicable information in the several parts of these Contract Documents.

1.2 MOBILIZATION AND DEMOBILIZATION

- A. Contractor shall be responsible for mobilization and demobilization of labor, materials and equipment. Payment for mobilization and demobilization will be included in the lump sum price indicated in the BID. Parking for vehicles used on site will be determined by the ENGINEER prior to mobilization.

B. DAILY REPORTS

- 1) The CONTRACTOR shall submit daily reports of construction activities for each site, including non-work days. The report shall include:
  - a) Manpower, number of workers by craft
  - b) Quality Control
  - c) Equipment on the Project
  - d) Major deliveries
  - e) Activities worked
  - f) New problems
  - g) Other pertinent information
- 2) A similar report shall be submitted for/by each Subcontractor.
- 3) The reports shall be submitted to the ENGINEER upon request.

1.3 SCHEDULING

- A. Prior to starting the work, confer with the ENGINEER and Owner's representative to develop an approved work schedule. Which will permit the surrounding facilities to function as normally as practical. It may be necessary to do certain parts of the work outside normal working hours to avoid undesirable conditions. The Contractor shall do this work at such times and at no additional cost to the Owner.
- B. SPECIAL EVENTS: Contractor may be asked to stop work during special events.

1.4 COORDINATION

- A. Contractors shall cooperate in the coordination of their separate activities in a manner that will provide the least interference with the Owner's operations and other contractors and utility companies working in the area, and in the interfacing and connection of the separate elements of the overall project work.

- B. If any difficulty or dispute should arise in the accomplishment of the above, the problem shall be brought immediately to the attention of the ENGINEER.
- C. CONTRACTOR shall notify all residents and proprietors adjacent to construction site of work to be performed, more specifically the notice shall state the day and time construction will begin, the name and phone number of the Contractor's representative responsible for the completion of the proposed improvements. Notice shall also include the Owner's representative for the project.

#### 1.5 SITE INVESTIGATION AND REPRESENTATION

- A. The Contractor acknowledges satisfaction as to the nature and location of the work, the general and local conditions, particularly those bearing upon availability of transportation, access to the site, disposal, handling and storage of materials, availability of labor, water, electric power, roads, and uncertainties of weather, or similar physical conditions at the site, the conformation and conditions at the site, the character of equipment and facilities needed preliminary to and during the prosecution of the work, and all other matters which can any way affect the work or the cost thereof under this Contract.
- B. The Contractor further acknowledges satisfaction as to character, quality, and quantity of surface and subsurface materials to be encountered from his inspection of the site and from reviewing any available records of exploratory work furnished by the Owner or included in these Documents. Failure by the Contractor to become acquainted with the physical conditions of the site and all available information will not relieve the Contractor from responsibility for properly estimating the difficulty or cost of successfully performing the work.
- C. The Contractor warrants that as a result of examination and investigation of all the aforesaid data, the contractor can perform the work in a good and workmanlike manner and to the satisfaction of the Owner.
- D. The Owner assumes no responsibility for any representations made by any of its officers or agents during or prior to the execution of this Contract, unless (1) such representations are expressly stated in the Contract, and (2) the Contract expressly provides that the responsibility therefore is assumed by the Owner.

#### 1.6 INFORMATION ON SITE CONDITIONS

- A. General: Any information obtained by the ENGINEER regarding site conditions, subsurface information, water level, existing construction of site facilities as applicable, and similar data will be available for inspection at the office of the ENGINEER upon request. Such information is offered as supplementary information only. Neither the ENGINEER nor the Owner assumes any responsibility for the completeness or interpretation of such supplementary information.

#### 1.7 DIFFERING SUBSURFACE CONDITIONS

- A. The ENGINEER shall investigate such conditions promptly and following this investigation, the Contractor shall proceed with the work, unless otherwise instructed by the ENGINEER. If the ENGINEER finds that such conditions do so materially differ and cause an increase or



decrease in the cost of, or in the time required for performing the work, the ENGINEER will recommend to the Owner the amount of adjustment in cost and time he considers reasonable. The Owner will make the final decision on all Change Orders to the Contract regarding any adjustment in cost or time for completion.

## 1.8 UTILITIES

- A. During excavation, the Contractor shall be responsible for determining, at his cost, the locations of all known utilities in the project area.
- B. Contractor shall notify utility location service (e.g. Call Sunshine 1-800-432-4770) a minimum for 48 hours prior to work order mobilization. Assigned notification number shall be maintained at the job site at all times and recorded in the daily reports.

## 1.9 CONTRACTOR'S RESPONSIBILITY FOR UTILITY PROPERTIES AND SERVICE

- A. Where the Contractor's operations could cause damage or inconvenience to telephone, television, gas, water, sewer, or irrigation systems, the operations shall be suspended until all arrangements necessary for the protection of these utilities and services have been made by the Contractor.
- B. Notify all utility offices, which are affected by the construction operation at least 48 hours in advance. Under no circumstances expose any utility without first obtaining permission from the appropriate agency. Once permission has been granted, locate, expose, and provide temporary support for all existing underground utilities.
- C. The Contractor shall be solely and directly responsible to the Owner and operators of such properties for any damage, injury, expense, loss, inconvenience, delay, suits, actions, or claims of any character brought because of any injuries or damage which may result from the construction operations under this Contract
- D. Neither the Owner nor its Officers or agents shall be responsible to the Contractor for damages as a result of the Contractor's failure to protect utilities encountered in the work.
- E. In the event of interruption to domestic water, sewer, storm drain, or other utility services as a result of accidental breakage due to construction operations, promptly notify the proper authority. Cooperate with said authority in restoration of service as promptly as possible and bear all costs of repair. In no case shall interruption of any water or utility service be allowed to exist outside working hours unless prior approval is granted.
- F. In the event the Contractor encounters water service lines that interfere with trenching, he may, by obtaining prior approval of the property owner, Florida Keys Aqueduct Authority (FKAA), or Fire Department as applicable, and the ENGINEER, cut the service dig through, and restore service with similar and equal materials at the Contractor's expense.
- G. The Contractor shall replace, at his own expense, all existing utilities or structures removed or damaged during construction, unless otherwise provided for in these Contract Documents or ordered by the ENGINEER.

#### 1.10 TEMPORARY WATER

- A. The Contractor shall make his own arrangements to obtain suitable water for any need and shall pay all costs.

#### 1.11 TEMPORARY ELECTRIC POWER

- A. The Contractor shall make his own arrangements to obtain and pay for electrical power used until final acceptance by the Owner.

#### 1.12 SAFETY REQUIREMENTS FOR TEMPORARY ELECTRIC POWER

- A. Temporary electric power installation shall meet the construction Safety requirements of OSHA, State, and other governing agencies.

#### 1.13 SANITARY FACILITIES

- A. The Contractor shall provide and maintain sanitary facilities for his employees and his subcontractor's employees that will comply with the regulations of the local and State Departments of Health and as directed by the Owner.

#### 1.14 STORAGE OF MATERIALS

- A. Materials shall be so stored as to ensure the preservation of their quality and fitness for the work. When considered necessary, they shall be placed on wooden platforms or other clean hard surfaces and not on the ground. Stored materials shall be located so as to facilitate prompt inspection. Stored materials on city property must be safe and secured from the general public and if necessary they must be fitted with lights at night. Private property shall not be used for storage purposes without the written permission of the owner or lessee. Materials shall not be stored where access to any structure, plot, or road is blocked. Location of stored materials approved by the ENGINEER or his designee.
- B. Delicate instruments and materials subject to vandalism shall be placed under lock cover and, if necessary, provided with temperature control as recommended by the manufacturer.

#### 1.15 CONSTRUCTION SAFETY PROGRAM

- A. The Contractor shall develop and maintain for the duration of this Contract, a safety program that will effectively incorporate and implement all required safety provisions. The Contractor shall appoint an employee who is qualified and authorized to supervise and enforce compliance with the safety program.
- B. The duty of the ENGINEER to conduct construction review of the Contractor's performance is not intended to include a review or approval of the adequacy of the Contractor's safety supervisor, the safety program or any safety measures taken in, on, or near the construction site.
- C. The Contractor shall do all work necessary to protect the public from hazards, including, but not limited to, surface irregularities, or unramped grade changes on pedestrian walkways and

docks. Barricades, lights, and proper signs shall be furnished in sufficient amount to safeguard the public and the work.

- D. The performance of all work shall be in accordance with the applicable governing safety authorities.

#### 1.16 ACCIDENT REPORTS

- A. If death or serious injuries or serious damages are caused; the Contractor must promptly report by telephone or messenger to the ENGINEER. In addition, the Contractor must promptly report in writing to the ENGINEER all accidents whatsoever arising out of or in connection with, the performance of the work whether on, or adjacent, to the site, giving full details and statements of witnesses.
- B. If a claim is made against the Contractor or any subcontractor on account of any accident, the Contractor shall promptly report the facts in writing to the ENGINEER, giving full details of the claim.

#### 1.17 FIRE PREVENTION AND PROTECTION

- A. The Contractor shall perform all work in a fire-safe manner and shall supply and maintain on the site adequate fire-fighting equipment capable of extinguishing incipient fires. The Contractor shall comply with applicable federal, state, and local fire-prevention regulations. Where these regulations do not apply, applicable parts of the National Fire Prevention Standard for Safeguarding Building Construction Operations (NFPA No. 241) shall be followed.

#### 1.18 SITE RESTORATION AND CLEANUP:

- A. At all times during the work keep the premises clean and orderly and upon completion of daily work repair all damage caused by equipment and leave the project free of rubbish or excess materials of any kind.
- B. Stockpile excavated materials in a manner that will cause the least damage to adjacent lawns, grassed areas, gardens, shrubbery, or fences regardless of whether these are on private property, or State, County, or City rights-of-way. Remove all excavated materials from grassed and planted areas and leave these surfaces in a condition equivalent to their original condition.

#### 1.19 FINISHING OF SITE AND STORAGE AREAS

- A. Upon completion of the project, all areas used by the Contractor shall be properly cleared of all temporary structures, rubbish and waste materials and properly graded to drain and blend in with the abutting property. Areas used for the deposit of waste materials shall be finished to properly drain and blend in with the surrounding terrain.

#### 1.20 AREA CLEANUP DURING CONSTRUCTION

- A. Thoroughly clean all spilled dirt, gravel, sand or other foreign materials caused by the construction operations from all streets and roads, grass, pathways, docks or concrete walkways and from adjacent areas at the conclusion of each day's operation. Truck or equipment wash down is not to be performed on City Property.

1.21 PREVENTION

- A. Applicable environmental regulations shall be strictly adhered to.

1.22 SUBMITTALS

- A. See Submittals section of the specifications

1.23 PAYMENT

- A. The cost of the work in this section is considered incidental to the contract.

**END OF SECTION**

**SECTION 01010**  
**SCOPE OF WORK**

The project proposed consists of providing all materials, equipment and labor necessary to construct shelters at C.B. Harvey Rest Beach.

**1.1 DESCRIPTION**

Remove existing, deteriorated structure and construct three timber shelters including new 10' x 10' concrete slabs detailed in the specifications and drawing for REST BEACH SHELTERS / ITB 22-002 including all site work and necessary appurtenances, record drawings, and incidental work to provide a complete and serviceable project identified as:

**A. ITB**

**– C.B. HARVEY REST BEACH SHELTERS**

B. Related requirements in other parts of the Contract Documents: Include but not limited to:

1. General and Supplementary Conditions of the Contract for Construction.

**1.2 CONTRACTOR'S DUTIES:**

A. In addition to provisions stipulated in other portions of the Contract Documents, the Contractor shall:

1. Secure permits as necessary for proper execution and completion of the work. The CITY will secure a Coastal Construction Control Line permit from the Florida Department of Environmental Protection (FDEP) to work within 50 feet of the mean high-water line. Contractor must indemnify the FDEP & TDC. All conditions of the permit must be adhered to by the contractor.

2. Notify (in writing) all vendors, residents and proprietors adjacent to construction site of work to be performed, more specifically the notice shall state the day and time construction will begin, hours of work, the name and phone number of the Contractor's Superintendent and an end date for the project.

B. The Contractor shall be totally responsible for securing and complying with all, required permits and payment of associated fees. Contractor shall ensure that construction complies with all applicable local, state, and federal codes.

C. Provide an experienced, qualified, and competent Superintendent able to read, write and speak English to oversee the work and perform quality assurance inspections. Prior to starting construction, the proposed Superintendent's qualifications shall be submitted in writing to the City for approval. The approved Superintendent shall be expected to remain for the duration of the Project, unless the City or ENGINEER deem them inadequate and requests his/her removal or the Contractor cannot continue his services to the Project for a reason or reasons that shall be communicated in writing to the City.

D. The Superintendent shall provide to the City, upon request, Construction Reports for each day

of construction, the reports shall be in English, legible, and signed. Contractor shall provide PDF copies monthly. Reports shall include quantity control checks.

E. It shall be the Contractor's responsibility to comply with the City's Ordinance

**Chapter 26 Environment, Article IV. Sound Control** below:

**Sec. 26-193. - Exceptions.**

The prohibitions contained in this article shall not apply to the following:

(3) Construction/demolition. Sound levels produced from tools and equipment in commercial construction, demolition, drilling, or reasonably similar activities. However, such sound levels are limited to the hours of 8:00 a.m. to 7:00 p.m., Monday through Friday, and 9:00 a.m. to 5:00 p.m. on Saturday. The tools and equipment must be muffled and maintained equal to the functional standards of the industry. No exceptions contained in this subsection shall apply on Thanksgiving Day, Christmas Day and New Year's Day.

F. The Contractors is responsible for the installation of all building, concrete walkways, lift station and all associated items used in the completion of the project. Contractor is responsible for all costs associated with the disposal of materials and must dispose of in an environmentally responsible manner.

G. The Contractor shall provide material safety data sheets (2 copies) for chemicals, paints, coatings and materials used on-site prior to initiation of work.

**1.3 CONTRACTOR'S USE OF PREMISES**

A. Work shall be scheduled as to not interfere with on-going area activities.

B. Coordinate use of premises and requirements for security under direction of City.

C. Assume full responsibility for the protection and safekeeping of products, under this Contract, stored on the site.

D. Obtain and pay for the use of additional storage or work areas needed for operation.

**1.4 MAINTENANCE OF EXISTING UTILITIES OPERATION**

A. Provide at least three weeks' notice prior to interruption of utility services for temporary or permanent connections.

B. Keep interruption of utility services, and utility outages during disconnection, moving, and reconnection to a minimum.

**END OF SECTION**



---

---

**PART 5**

**DRAWINGS**

---

---



**GENERAL REQUIREMENTS:**

1. THE CONTRACTOR SHALL WORK THE CONTRACTOR SHALL REVIEW THESE PLANS AND SITE CONDITIONS AND NOTIFY THE ENGINEER IF ANY DISCREPANCIES ARE DETERMINED.
2. THE ENGINEER IS NOT RESPONSIBLE FOR ANY DISCREPANCIES OF THE CONTRACTOR NOR HIS SUBS.
3. THE CONTRACTOR SHALL PROVIDE MEANS AND ESTABLISH METHODS OF THE CONSTRUCTION TO MEET REQUIREMENTS OF ALL APPLICABLE CODES, INDUSTRY STANDARDS AND REQUIREMENTS OF THESE PLANS.
4. ANY DEVIATIONS FROM THESE PLANS SHALL BE REVIEWED AND APPROVED BY THE ENGINEER.

**SUBMITTALS:**

1. THE CONTRACTOR SHALL PROVIDE 5 ORIGINAL SUBMITTALS FOR ALL MATERIALS, PRODUCTS AND ACCESSORIES USED FOR THIS PROJECT (NO EXCEPTIONS).
2. THE CONTRACTOR SHALL SUBMIT THE SUBMITTALS TO THE ENGINEER FOR REVIEW BY THE GENERAL CONTRACTOR REPRESENTATIVE PRIOR TO SUBMITTING FOR ENGINEER'S REVIEW.
3. THE CONTRACTOR SHALL PREPARE AND MAINTAIN SUBMITTAL LOG FOR ALL PRODUCT WITH THE ENGINEER'S REVIEW.
4. THE CONTRACTOR SHALL PLAN IN ADVANCE FOR TIMELY PREPARATION OF ALL SUBMITTALS AND ALLOW 2-3 WEEKS FOR REVIEW AND CORRECTION PROCESS.

**DESIGN DATA:**

1. APPLICABLE BUILDING CODE: FBC 6TH EDITION (2017)
  2. DESIGN WIND SPEED: 150 MPH (1300 LB/ODIC)
  3. BASIC WIND SPEED: 180 MPH
  4. EXPOSURE: D
  5. CATEGORY: II
  6. FLOOD ZONE: VE 10
  7. FLOOD RESISTANT DESIGN AND CONSTRUCTION PER ASCE 24-14
  8. FLOOD DESIGN CHAIRS: 2" W/1 FLOOD PLATING
- ALL PRESSURES SHOWN ARE BASED ON ASD DESIGN WITH A LOAD FACTOR OF 0.5
- SOILS AND FOUNDATIONS:**

1. FOUNDATIONS SHALL BE USED ON A "SOUND MASONRY AND ENLARGED BENCH" WITH A ALLOWABLE LOAD BEARING PRESSURE OF 3,000 PSI. NOTIFY THE ENGINEER OF SOIL CONDITIONS IF DIFFERENT.
2. ALL FOUNDATIONS, SLABS AND FOOTERS SHALL BE PLACED ON STABILIZED UNDISTURBED SUBGRADE SOIL.
3. MINIMUM FOUNDATION DEPTH SHALL BE 24" UNLESS OTHERWISE IS SPECIFIED ON THE SUBGRADE SOIL.
4. ALL FOUNDATIONS SHALL BE USED ONLY IF APPROVED BY THE ENGINEER.
5. FILL UNDER THE FOUNDATIONS SHALL BE 18" LAYERS AND COMPACTED TO 95% DENSITY USING THE MODIFIED PROCTOR TEST.
6. FILL MATERIAL SHALL BE CLEAN GRANULAR SAND OR UNDERCLOK MIX WITHOUT ANY CONTAIN ANY WOOD OR CELLULOSE DEBRIS.

**ALUECAST PILES:**

1. ALL PILES SHALL BE 16" DIAMETER WITH MINIMUM EMBEDMENT OF 3FT INTO THE CAP ROCK UNLESS OTHERWISE SHOWN ON THE PLANS.
2. CONCRETE FOR PILES SHALL HAVE A MIN. COMPRESSIVE STRENGTH OF 5000 PSI. WATER CEMENT RATIO SHALL NOT EXCEED 0.45.
3. REINFORCEMENT SHALL BE FOUR (4) #5 REBAR VERTICALLY WITH #3 HOOPS AT 10" O.C. CONTRACTOR SHALL USE PLASTIC CHAIRS OR CENTRALIZERS TO PROVIDE A 3" COVER ON ALL SIDES OF THE REINFORCEMENT.

**CONCRETE:**

1. APPLICATION OF ACI 318 LATEST EDITION AND ACI 301.
2. UNLESS OTHERWISE IS SHOWN IN THE PLANS, WATER CEMENT RATIO SHALL NOT EXCEED W/C=0.40.
3. ACI 305R-10 "HOT WEATHER CONCRETING".
4. ALL EXPOSED EDGES SHALL HAVE 1/2" CHAMFER.
5. ALL CONCRETE SHALL BE TESTED AND LABRATORY TESTING SHALL BE PERFORMED BY THE TESTING SPECIALIZED COMPANY.
6. INDEPENDENT TESTING RESPONSIBLE FOR ALL SCHEDULING, COORDINATION AND COST OF THE CONCRETE.
7. THREE (3) SAMPLES SHALL BE TAKEN AND TESTED EACH TIME.
8. MINIMUM SAMPLING FREQUENCY:
9. (A) EVERY 50 CUBIC YARDS;
10. (B) EVERY 200 SQ.FT. OF SLAB AREA;
11. (C) EVERY 2000 SQ.FT. OF SLAB AREA.

1. ALL TESTING SHALL BE PER LATEST ACI AND ASTM REQUIREMENTS.
2. LABORATORY SHALL SUPPLY THREE (3) ORIGINAL SIGNED & SEALED REPORT RESULTS TO THE ENGINEER.
3. CAST-IN-PLACE AND PRECAST MEMBERS ERECTION TOLERANCES SHALL BE AS SPECIFIED IN TABLE B.2.2 OR IN SECTION B.3 OF PCI DESIGN HANDBOOK/SIXTH EDITION".

**REINFORCEMENT:**

1. REINFORCEMENT SHALL BE ASTM A1035 GRADE 100 (DINRMX 9100) AS DISCUSSION.
2. ALL REQUIREMENTS FOR PLACEMENT, COVER, TOLERANCES, ETC. SHALL BE PER ACI 308.
3. ALL JOISTS AND BEAMS SHALL BE FACTORY MADE UNLESS FIELD BENDS ARE APPROVED BY THE ENGINEER.
4. ONLY PLASTIC CHAIRS AND CENTRALIZERS SHALL BE USED FOR REBAR SUPPORT.

**STRUCTURAL LUMBER:**

1. NATIONAL DESIGN SPECIFICATION (NDS) FOR WOOD CONSTRUCTION" AND ALL REFERENCED STANDARDS.
2. ALL WOOD MEMBERS SHALL BE SOUPEK PINE NO.2 OR GREATER KILN DRIED AS SPECIFIED IN THE STANDARDS, UNLESS OTHERWISE SPECIFIED.
3. ALL WOOD MEMBERS EXPOSED TO EXTREMITY, IN DIRECT CONTACT WITH CONCRETE OR STEEL SHALL BE TREATED WITH PRESERVATIVE AS SPECIFIED IN THE NDS OR NFA STANDARDS.
4. ALL FIELD JOINTS IN PT UNDER SHALL BE TREATED ON BITE.
5. NAILING SHALL BE IN ACCORDANCE WITH FBC 2017. NAILS AND OTHER FASTENERS FOR PT JOINTS SHALL BE 5/8" O.D. COX PLAYWOOD OR APPROVED EQUIVALENTS UNLESS OTHERWISE IS SPECIFIED ON THE PLANS. USE 10D RING-SHANK NAILS WITH SPACING OF 4" O.C. ON ALL EDGES AND 5" O.C. IN THE FIELD.

**HARDWARE:**

1. HARDWARE SHALL BE 316 STAINLESS STEEL OR BETTER OR ZMAX GALVANIZED FOR NON CORROSION.
2. ALL CONNECTORS SHALL HAVE STAINLESS STEEL SCREWS AND FASTENERS OR ACO APPROVED TREATED FOR NON EXTENDED LOCATIONS).

**REINFORCED MASONRY (CMU)**

1. ALL MASONRY SHALL BE REINFORCED CONCRETE MASONRY UNIT IN ACCORDANCE WITH THE FBC 2017.
2. INITIAL ALL BLOCKS IN RUNNING BOND.
3. MINIMUM MASONRY BLOCK (ASTM C90) STRENGTH SHALL BE (F<sub>m</sub>) OF 1500 PSI.
4. ALL BLOCKS SHALL BE REINFORCED WITH #5 REBAR @ 24" O.C. UNLESS OTHERWISE IS SPECIFIED ON THE PLANS.
5. FILLED CELLS SHALL BE REINFORCED WITH #5 REBAR @ 24" O.C. UNLESS OTHERWISE IS SPECIFIED ON THE PLANS.
6. BACK BUMP MIX (ASTM C476) WITH A MINIMUM COMPRESSIVE STRENGTH OF 4000 PSI (28 DAY) (ASTM C1019). TARGETED SLUMP SHALL BE 8" ± 1".
7. EACH BRIDGED CELL SHALL HAVE DRAINAGE OPENINGS AT THE BOTTOM. THERE SHALL BE WASHING FOR SURFACE PREPARATION.

**STRUCTURAL STEEL:**

1. STRUCTURAL STEEL COMPONENTS SHALL BE AS SPECIFIED IN SPECIFICATIONS FOR STRUCTURAL STEEL BUILDINGS ALSO 2005 OR LATEST EDITION.
2. WELDS SHALL BE PER AISC 360 (FY=46 KSI).
3. STEEL PLATES, FLANGES AND MISCELLANEOUS ELEMENTS SHALL BE ASTM A36 (FY=36 KSI) UNLESS NOTED OTHERWISE ON THE PLANS.
4. ALL WELDING SHALL BE IN CONFORMANCE WITH THE LATEST SPECIFICATIONS AWS D1.1/D1.1M:2017, STRUCTURAL WELDING CODE - STEEL.
5. ALL BOLTS SHALL BE PER AISC 308, STRUCTURAL BOLTS, F436 WASHERS.
6. ANCHOR BOLTS: HOT DIP GALVANIZED, A307 GRADE A, A563RDH HEX NUTS, F644 WASHERS.

**STRUCTURAL STEEL COATING:**

1. ALL SURFACES SHALL BE ABRASIVE BLAST CLEANED TO NEAR-WHITE METAL (PER EXPOSED STEEL).
2. ALL SURFACES SHALL BE PRIME WITH POLYAMIDE EPOXY - ONE COAT (8.0 MILS DFT).
3. ALL SURFACES SHALL BE FINISHED WITH POLYURETHANE - ONE COAT (8.0 MILS DFT).
4. TOP LAYER SHALL BE TWO (2) COAT POLYURETHANE (3.0 MILS DFT EACH).
5. COLOUR SHALL MATCH EXISTING OR TO BE SELECTED BY THE ENGINEER.
6. COLOURS SHALL MATCH EXISTING OR TO BE SELECTED BY THE ENGINEER.
7. 2 COATS OF "SUMTER COATINGS" UNIVERSAL PRIMER (5.0 MILS DFT) OR APPROVED EQUAL.

**ALUMINUM COMPONENTS:**

1. TYPE 6061-T6 ALUMINUM.
2. ALL ALUMINUM IN CONTACT WITH CONCRETE, PT WOOD, DISSIMILAR FILLER WIRE ALLOW.
3. ALL ALUMINUM IN CONTACT WITH CONCRETE, PT WOOD, DISSIMILAR FILLER WIRE ALLOW.
4. ALL ALUMINUM IN CONTACT WITH CONCRETE, PT WOOD, DISSIMILAR FILLER WIRE ALLOW.
5. ALL ALUMINUM IN CONTACT WITH CONCRETE, PT WOOD, DISSIMILAR FILLER WIRE ALLOW.
6. ALL ALUMINUM IN CONTACT WITH CONCRETE, PT WOOD, DISSIMILAR FILLER WIRE ALLOW.
7. ALL ALUMINUM IN CONTACT WITH CONCRETE, PT WOOD, DISSIMILAR FILLER WIRE ALLOW.

**OPENINGS:**

1. ALL WINDOW AND DOOR OPENINGS SHALL BE LARGE AND SMALL MISSILE IMPACT RATED OR HAVE CODE COMPLIANT SHUTTERS.
2. ALL EXTERIOR WINDOWS AND DOORS SHALL HAVE FLORIDA PRODUCT APPROVAL FRAME. PRODUCT APPROVAL LABELS SHALL BE PERMANENTLY ATTACHED TO THE FRAME.
3. Wind Pressure on Components and Claddings (Ch 30 Part 1)

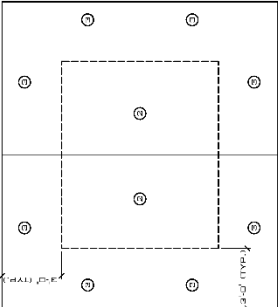

ROOF WIND PRESSURES DIAGRAM  
SCALE: NTS

NO. 177480-01  
SCALE: FINAL

**ARTIBUS DESIGN**  
ENGINEERING AND PLANNING

ARTIBUS DESIGN  
3706 N. ROOSEVELT BLVD  
KEY WEST, FL 33040  
WWW.ARTIBUSDESIGN.COM  
CA # 30835

CITY OF KEY WEST  
1300 WHITE OAK  
KEY WEST, FL 33040  
PROJECT: REST BEACH PAVILIONS

DATE: 1907-20  
DRAWN BY: S-100  
CHECKED BY: PER  
DATE: 1907-20

Digitally signed  
by Serge Mashtakov P.E.  
71480 State of  
Florida  
Date: 2019.08.19  
16:31:05 -0400

THIS DRAWING IS ACT VALID WITHOUT THE SIGNATURE AND ORIGINAL SEAL.

STATE OF FLORIDA  
PROFESSIONAL ENGINEER  
SERGE MASHTAKOV  
No. 71480  
DATE: 1907-20

DESCRIPTION	WIDTH	SPAN	AREA	PERF.	PERF.
ZONE 1	1	1	1	1	1
ZONE 2	1	1	1	1	1
ZONE 3	1	1	1	1	1

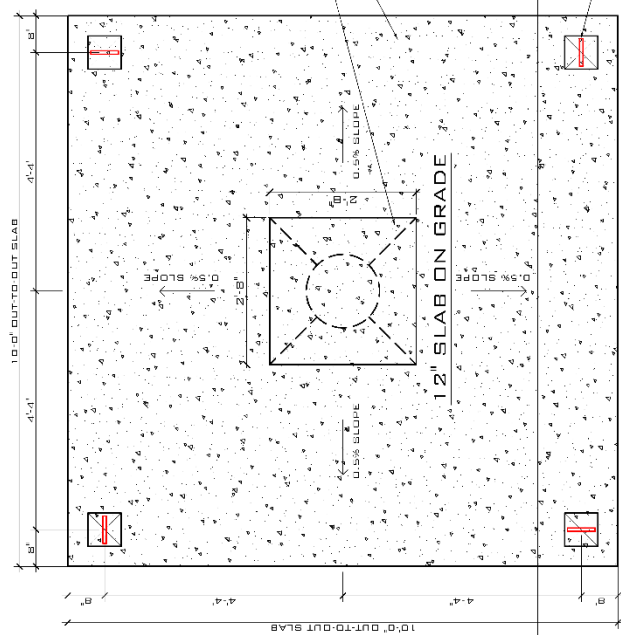

FOUNDATIONS LEGEND	
SYMBOL	DESCRIPTION
	12" DIA. AUGERCAST PILES 5000 PSI CONCRETE, W/ (4) #5 REBAR W/ #3 STIRRUPS @ 12" O.C. 5' BELOW GRADE OR MIN. EMBEDMENT 2' INTO CAP ROCK.
	8'X8' PT BR#2 POST W/ 3/4" 316SS PLATE CONCEALED IN THE POST AND (4) 3/4" DIA. 30316 STAINLESS STEEL BOLTS AS PER DETAIL 1/8104. SEE PLAN FOR PLATE ORIENTATION IN EACH POST.

**FOUNDATION PLAN**  
SCALE: 1/2" = 1'-0"

NO. 172480-01  
SHEET: FINAL



**ARTIBUS DESIGN**  
ENGINEERING AND PLANNING  
3706 N. RIVERVIEW BLVD  
SUITE 100  
KEY WEST, FL 33040  
305.854.1111  
WWW.ARTIBUSDESIGN.COM  
CA # 30835

PROJECT: CITY OF KEY WEST REST BEACH PAVILIONS  
1300 WHITE CT.  
KEY WEST, FL 33040

DATE: 1907-20  
DRAWN: S-101  
CHECKED: PER  
PROJECT NO. 172480-01

THIS DRAWING IS ACT VALID WITHOUT THE SIGNATURE AND ORIGINAL SEAL

**Digitally signed by Serge Mashtakov**  
P.E. 71480 State of Florida

Date: 2019.08.19  
Time: 16:30:50 -04'00'

SERGE MASHTAKOV  
PROFESSIONAL ENGINEER  
STATE OF FLORIDA  
LICENSE NO. 71480



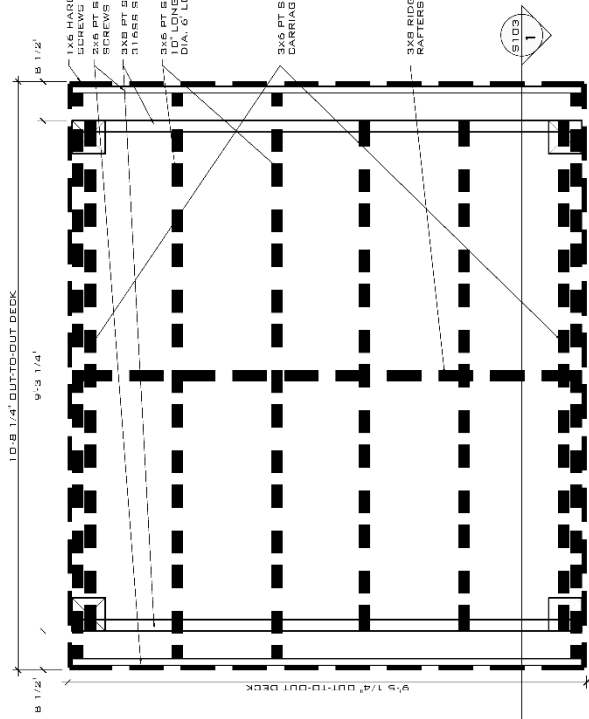

10'-8 1/4" OUTTO-OUT DECK  
 9'-3 1/4"  
 9'-3 1/4" OUTTO-OUT DECK

1x6 HARDIE FIBER CEMENT BOARD W/12" #9 2-1/4" STAINLESS STEEL SCREWS AT 12" O.C.  
 3/8" PT SP#2 BEAM BEARINGS IN ROOF POCKET W/12" 3/4" DIA. ALUMINUM STAINLESS STEEL LAG SCREWS AT RIDGE BEAM END

3/8" PT SP#2 BEAM BEARINGS IN ROOF POCKET W/12" 3/4" DIA. ALUMINUM STAINLESS STEEL LAG SCREWS AT RIDGE BEAM END

31.6SS STAINLESS STEEL BOLTS STAGGERED EACH POCKET END

3x6 PT SP#2 RAFTERS AT EQUAL SPACING UNDER 24" O.C. W/11 1/2" DIA. ALUMINUM STAINLESS STEEL LAG SCREWS AT RIDGE BEAM END

3x6 PT SP#2 TIES W/12" 5/8" DIA. 31.6SS STAINLESS STEEL CARRIAGE BOLTS TO THE END RAFTERS

3x8 RIDGE BEAM W/ MSTA3AZ STRAP OVER THE RIDGE BEAM AND RAFTERS INSTALLED OVER T&G DECK



ROOF FRAMING PLAN  
 SCALE: 1/2" = 1'-0"

NO. 172480  
 SHEET FINAL



ARTIBUS DESIGN  
 3706 N. ROUBELVIL BLVD  
 KEY WEST, FL 33040  
 WWW.ARTIBUSDESIGN.COM  
 CA # 30835

CITY OF KEY WEST  
 DEPARTMENT  
 1300 WHITE CT  
 KEY WEST, FL 33040  
 REST BEACH PAVILIONS

DATE	1907-20	DATE	1907-20
BY	SM	BY	SM
CHECKED	SM	CHECKED	SM
PROJECT	REST BEACH PAVILIONS	PROJECT	REST BEACH PAVILIONS
SCALE	1/2" = 1'-0"	SCALE	1/2" = 1'-0"

THIS DRAWING IS ACT VALID WITHOUT THE SIGNATURE AND ORIGINAL SEAL

Digitally signed by  
 Serge Mashtakov  
 P.E. 71480 State of  
 Florida  
 Date: 2019.08.19  
 16:30:35 -04'00'

SEGE MASHTAKOV  
 PROFESSIONAL ENGINEER  
 STATE OF FLORIDA  
 LICENSE NO 71480

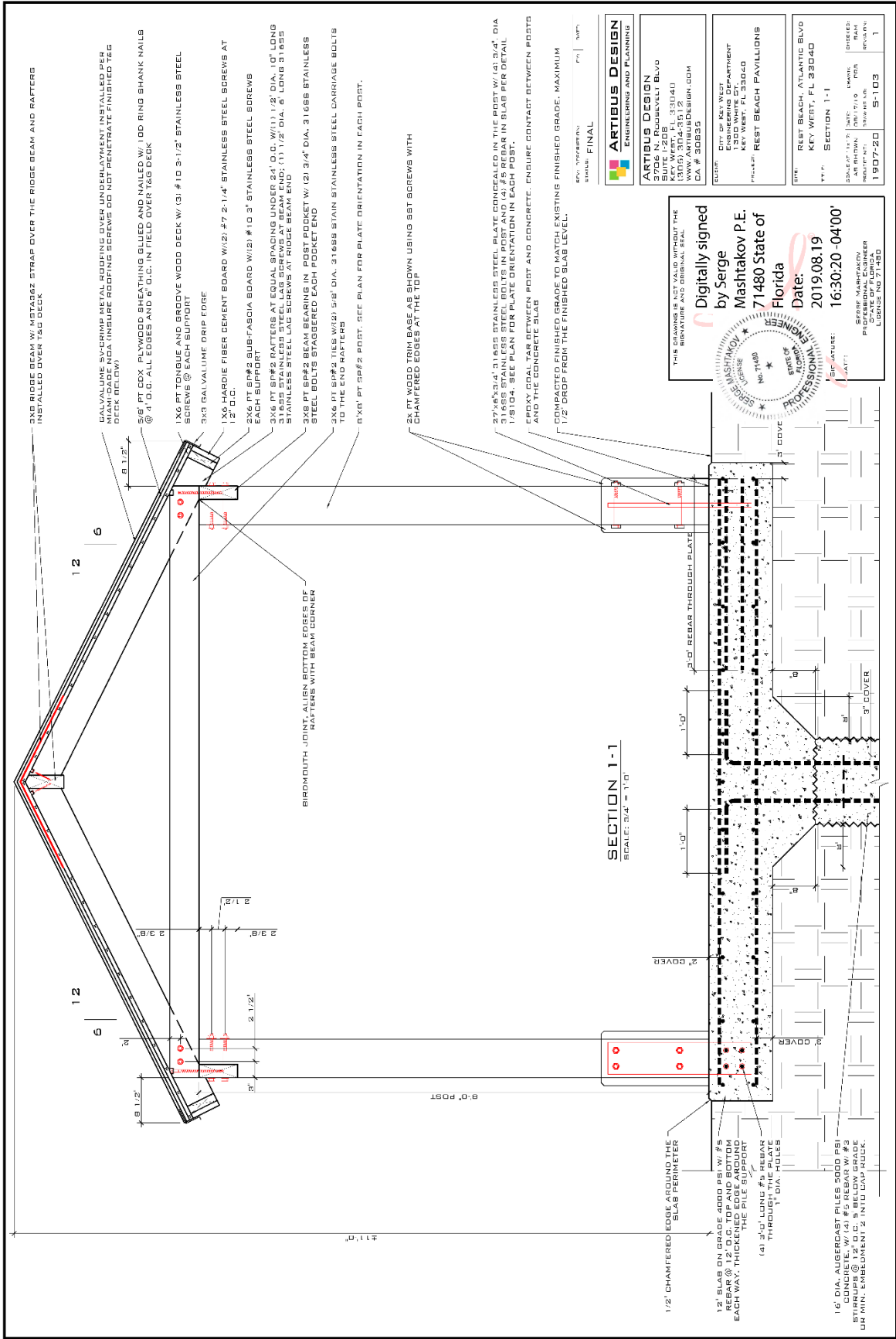

3x8 RIDGE BEAM W/ MSTAR62 STRAP OVER THE RIDGE BEAM AND RAFTERS  
INSTALLED OVER T&G DECK

DALVULINE 3/4" CRIMP METAL ROOFING OVER UNDERLAYMENT INSTALLED PER  
MANUFACTURER'S INSTRUCTIONS. INSURE ROOFING SCREWS DO NOT PENETRATE FINISHED T&G  
DECK (BELOW)

5/8" PT CDX PLYWOOD SHEATHING GLUED AND NAILED W/ 1" DD RING SHANK NAILS  
@ 4" O.C. ALL EDGES AND 6" O.C. IN FIELD OVER T&G DECK

1x6 PT TONGUE AND GROOVE WOOD DECK W/ (3) # 10 3-1/2" STAINLESS STEEL  
SCREWS @ EACH SUPPORT

3x3 GALVALUME DRIP EDGE

1x6 HARDIE FIBER CEMENT BOARD W/ (2) # 7 2-1/4" STAINLESS STEEL SCREWS AT  
1/2" O.C.

2x6 PT SP#2 SUBTASCIA BOARD W/ (2) # 10 3" STAINLESS STEEL SCREWS  
EACH SUPPORT

2x6 PT SP#2 RAFTERS AT EQUAL SPACING UNDER 2 1/2" O.C. W/ (1) 1/2" DIA. 1" LONG  
STAINLESS STEEL LAG SCREWS AT RIDGE BEAM END

3x8 PT SP#2 BEAM BEARING IN POST POCKET W/ (2) 3/4" DIA. 316SS STAINLESS  
STEEL BOLTS STAGGERED EACH POCKET END

2x4 PT SP#2 TIES W/ (2) 5/8" DIA. 316SS STAINLESS STEEL DARRAGE BOLTS  
TO THE END RAFTERS

6x6 PT SP#2 POST. SEE PLAN FOR PLATE ORIENTATION IN EACH POST.

2x4 PT WOOD FROM BASE AS SHOWN USING 98T SCREWS WITH  
CHAMFERED EDGES AT THE 10"

2x4x6x1/2" 316SS STAINLESS STEEL PLATE CONSIDERED IN THE POST W/ 61/2" DIA.  
316SS STAINLESS STEEL BOLTS IN POST AND 1/4" DIA. 316SS BEAR IN SLAB PER DETAIL  
1/5104. SEE PLAN FOR PLATE ORIENTATION IN EACH POST.

EPXY GYAL TAB BETWEEN POST AND CONCRETE. ENSURE CONTACT BETWEEN POSTS  
AND THE CONCRETE SLAB

CHAMFERED FINISHED GRADE TO MATCH EXISTING FINISHED GRADE. MAXIMUM  
1/2" DROP FROM THE FINISHED SLAB LEVEL.

12" SLAB ON GRADE 4000 PSI W/ #5  
REBAR PERIMETER  
THICKENED EDGE AROUND  
THE PILE SUPPORT

(2) 2x4" LONG #5 REBAR  
THROUGH THE PLATE  
1" DIA. HOLES

16" DIA. AUGERCAST PILES 5000 PSI  
CONCRETE. W/ (4) #5 REBAR W/ #3  
STIRRUPS @ 12" O.C. 5" BELOW GRADE  
OR MIN. EMBEDED 5" INTO CON. RUCK.

SECTION 1-1  
SCALE: 3/4" = 1'-0"

NO. 122487000  
SCALE: FINAL  
DATE: 08/19/2019



ARTIBUS DESIGN  
3706 N. ROOSEVELT BLVD  
KEY WEST, FL 33040  
WWW.ARTIBUSDESIGN.COM  
CA # 30835

PROJECT: CITY OF KEY WEST  
DEPARTMENT: 1300 WHITE CT.  
KEY WEST, FL 33040  
PROJECT: REST BEACH PAVILIONS

STATE: REST BEACH, ATLANTIC BLVD  
KEY WEST, FL 33040  
SECTION: 1-1  
DATE: 08/19/2019  
DRAWN: PIER  
CHECKED: PIER  
PROJECT NO: 1907-20  
SHEET NO: 5-109

THIS DRAWING IS ACT VALID WITHOUT THE  
SIGNATURE AND ORIGINAL SEAL

Digitally signed  
by Serge  
Mashtakov P.E.  
71480 State of  
Florida  
Date: 2019.08.19  
16:30:20 -0400

SEAL: SERGE MASHTAKOV  
NO. 122487000  
STATE OF FLORIDA  
PROFESSIONAL ENGINEER  
EXPIRES: 08/19/2024

SIGNATURE: [Signature]  
DATE: 2019.08.19  
16:30:20 -0400

SEAL: SERGE MASHTAKOV  
NO. 122487000  
STATE OF FLORIDA  
PROFESSIONAL ENGINEER  
EXPIRES: 08/19/2024





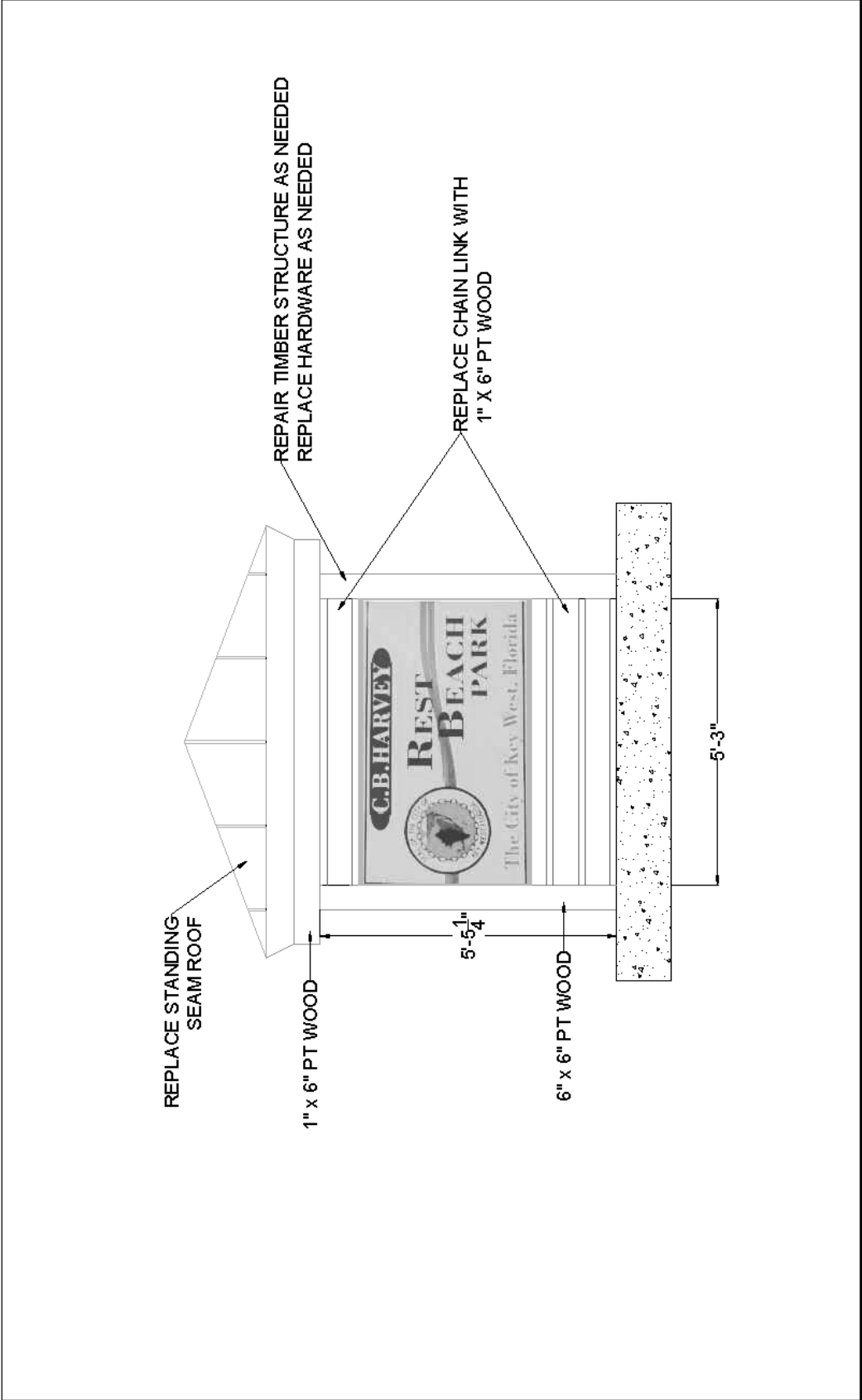

	<b>City of Key West</b> Engineering Services 1300 White Street, Key West, FL 33040	REVISION DATE: 01/16/2019	PROJECT	REST BEACH SHELTERS	SHEET	BEACH SIGN	SHEET NO. 1 OF 1
	REVISION						

# C.B. Harvey Rest Beach





# CONSTRUCTION PLANS FOR REST BEACH PAVILLIONS



LOCATION MAP: SITE LOCATION

CITY OF KEY WEST  
PURCHASE ORDER: 089800  
ARTIBUS DESIGN TASK ORDER #2005

PROJECT LOCATION:  
REST BEACH, ATLANTIC BLVD  
KEY WEST, FL 33040

## CONSTRUCTION SURFACE WATER MANAGEMENT PLAN

THE FOLLOWING NOTES HAVE BEEN DEVELOPED FOR THE CONTRACTOR'S USE IN GENERATING A STORMWATER POLLUTION PREVENTION PLAN IN ACCORDANCE WITH THE FLORIDA DEPARTMENT OF ENVIRONMENTAL PROTECTION'S (FDEP) GENERIC PERMIT FOR STORMWATER DISCHARGE FROM LARGE AND SMALL CONSTRUCTION ACTIVITIES. THE AFOREMENTIONED CONSTRUCTION GENERAL PERMIT (CGP) CONSTITUTES AUTHORIZATION TO DISCHARGE STORMWATER ASSOCIATED WITH INDUSTRIAL ACTIVITY TO SURFACE WATERS UNDER THE EPA'S 'NATIONAL POLLUTANT DISCHARGE ELIMINATION SYSTEM' (NPDES).

THE FOLLOWING ENTITIES ARE IDENTIFIED AS TEAM MEMBERS OF SWPPP: THE DEVELOPER AS IDENTIFIED ON THE COVER SHEET OF THESE PLANS, AND THE SITE CONTRACTOR AND HIS SUBCONTRACTORS. EACH TEAM MEMBER HAS SPECIFIC RESPONSIBILITIES AND OBLIGATIONS. IN GENERAL, ALL TEAM MEMBERS, WITH REGARD TO THEIR INVOLVEMENT AND RESPONSIBILITIES ON THE PROJECT, ARE TO IMPLEMENT ALL NECESSARY STORMWATER MANAGEMENT CONTROLS TO ASSURE COMPLIANCE WITH THE CGP, THE SOUTHWEST FLORIDA WATER MANAGEMENT DISTRICT PERMIT AND THE GUIDELINES LISTED IN THE SWPPP. THE DUTIES AND RESPONSIBILITIES OF THE TEAM MEMBERS AS THEY PERTAIN TO THE SWPPP ARE AS FOLLOWS:

### DEVELOPER

A. SUBMIT AND OBTAIN THE NECESSARY DESIGN-RELATED STORMWATER PERMITS FROM THE FLORIDA DEPARTMENT OF ENVIRONMENTAL PROTECTION, THE SOUTH FLORIDA WATER MANAGEMENT DISTRICT AND OTHER APPLICABLE GOVERNMENTAL BODIES.

B. SUBMIT TO SFWMD AND THE OPERATOR OF THE MUNICIPAL SEPARATE STORMWATER SYSTEM, IF APPLICABLE, A COPY OF THE NOTICE OF INTENT.

### CONTRACTOR

A. UPON NOTIFICATION BY THE DEVELOPER OF HIS INTENT TO COMMENCE CONSTRUCTION, SUBMIT A NOTICE OF INTENT TO THE DEPARTMENT OF ENVIRONMENTAL PROTECTION ON BEHALF OF THE DEVELOPER, ALONG WITH THE CERTIFICATION OF THE STORMWATER POLLUTION PREVENTION PLAN. ALSO, SUBMIT THE SFWMD PERMIT NUMBER OR COMPLETION LETTER IF THE PERMIT NUMBER IS NOT YET AVAILABLE. THIS SUBMITTAL WILL BE MADE NO LATER THAN 48 HOURS PRIOR TO BEGINNING OF CONSTRUCTION.

B. DEVELOP STORMWATER POLLUTION PREVENTION PLAN (SWPPP) INCLUDING, BUT NOT LIMITED TO, RETENTION/DETENTION PONDS, CONTROL STRUCTURES, EROSION CONTROL METHODS AND STABILIZATION CRITERIA. THIS DESIGN IS DEPICTED WITHIN THESE CONSTRUCTION PLANS AND THE FOLLOWING NOTES AND INSTRUCTIONS.

C. DURING CONSTRUCTION, ASSURE COMPLIANCE WITH THE DESIGNED STORMWATER POLLUTION PREVENTION PLANS AND THE FDEP GENERIC PERMIT FOR STORMWATER DISCHARGE FROM CONSTRUCTION ACTIVITIES THAT DISTURB FIVE OR MORE ACRES OF LAND.

D. MAINTAIN A COPY OF THE CONSTRUCTION PLANS, WHICH INCLUDE THE STORMWATER POLLUTION PREVENTION PLAN, THE NOI AND ALL INSPECTION REPORTS AND CERTIFICATIONS ON SITE.

E. UNDERTAKE ALL REASONABLE BEST MANAGEMENT PRACTICES (BMPs) TO ASSURE THAT SILTED OR OTHERWISE POLLUTED STORMWATER IS NOT ALLOWED TO DISCHARGE FROM THE SITE DURING ALL PHASES OF CONSTRUCTION. STABILIZATION BMPs THAT MAY BE USED INCLUDE: TEMPORARY OR PERMANENT SEEDING, MULCHING, GEOTEXTILES, SODDING, VEGETATIVE BUFFER STRIPS, PROTECTION OF TREES AND PRESERVATION OF MATURE VEGETATION. STRUCTURAL EROSION AND SEDIMENT CONTROL BMPs THAT MAY BE USED INCLUDE: STRAW BALE DIKES, SILT FENCES, EARTH DIKES, BRUSH BARRIERS, DRAINAGE SWALES, CHECK DAMS, SUBSURFACE DRAIN, PIPE SLOPE DRAIN, LEVEL SPREADERS, STORM DRAIN INLET PROTECTION, OUTLET PROTECTION, SEDIMENT TRAPS, AND TEMPORARY SEDIMENT BASINS. DETENTION PONDS SHALL BE USED AS TEMPORARY SEDIMENT BASINS. ADDITIONAL BMPs THAT MAY NEED TO BE IMPLEMENTED INCLUDE: PROVIDE PROTECTED STORAGE AREAS FOR CHEMICALS, PAINTS, SOLVENTS, FERTILIZERS, AND OTHER POTENTIALLY TOXIC MATERIALS; PROVIDING WASTE RECEPTACLES AT CONVENIENT LOCATIONS AND PROVIDE REGULAR COLLECTION OF WASTES, INCLUDING BUILDING MATERIAL WASTES; MINIMIZING OFF-SITE TRACKING OF SEDIMENTS; MAKING ADEQUATE PREPARATIONS, INCLUDING TRAINING AND EQUIPMENT TO CONTAIN SPILLS OF OIL AND HAZARDOUS MATERIALS; COMPLYING WITH APPLICABLE STATE OR LOCAL WASTE DISPOSAL, SANITARY SEWER OR SEPTIC SYSTEM REGULATIONS AND THE USE OF APPROPRIATE POLLUTION PREVENTION MEASURES FOR ALLOWABLE NON-STORM WATER COMPONENTS OF DISCHARGE.

F. NOTIFY THE DEVELOPER IN WRITING OF ANY NON-STORM WATER POLLUTION SOURCES WHICH ARE BEING STORED, OR OTHERWISE USED DURING THE CONSTRUCTION OF THE PROJECT, I.E., FERTILIZERS, FUELS, PESTICIDES, OTHER CHEMICALS. THIS NOTIFICATION SHOULD BE ACCOMPANIED WITH THE CONTRACTOR'S DESIGN AND METHODS TO PREVENT POLLUTION RUN-OFF FROM THESE SOURCES.

G. DEVELOP A MAINTENANCE AND INSPECTION PLAN WHICH INCLUDES, BUT IS NOT LIMITED TO THE FOLLOWING:

1. THE SPECIFIC AREAS TO BE INSPECTED AND MAINTAINED THAT INCLUDES ALL THE DISTURBED AREAS AND MATERIAL STORAGE AREAS OF THE SITE.
2. THE EROSION AND SEDIMENT CONTROLS IDENTIFIED IN THE SWPPP TO BE MAINTAINED AND INSPECTED AND THOSE ADDITIONAL CONTROLS WHICH THE CONTRACTOR DEEMS NECESSARY.
3. MAINTENANCE PROCEDURES.
4. THE PROCEDURE TO FOLLOW IF ADDITIONAL WORK IS REQUIRED OR WHOM TO CALL.
5. INSPECTIONS AND MAINTENANCE FORMS.
6. THE PERSONNEL ASSIGNED TO EACH TASK.

H. COMPLETE AND SUBMIT A NOTICE OF TERMINATION. THE NOT SHALL BE SUBMITTED NO MORE THAN 14 DAYS AFTER COMPLETION OF THE PROJECT AND FINAL STABILIZATION OF THE SITE. FINAL STABILIZATION AS DEFINED BY FDEP IS WHEN ALL SOIL DISTURBING ACTIVITIES AT THE SITE HAVE BEEN COMPLETED AND UNIFORM (E.G. EVENLY DISTRIBUTED, WITHOUT LARGE BARE AREAS) PERENNIAL VEGETATIVE COVER WITH A DENSITY OF 70% OF THE NATIVE BACKGROUND VEGETATIVE COVER FOR THE AREA HAS BEEN ESTABLISHED ON ALL UNPAVED AREAS AND AREAS NOT COVERED BY PERMANENT STRUCTURES. AS AN ALTERNATIVE, EQUIVALENT PERMANENT STABILIZATION MEASURES (SUCH AS RIP RAP, GABIONS, OR GEOTEXTILES) MAY BE EMPLOYED. THE CONTRACTOR SHALL NOTIFY THE ENGINEER AND DEVELOPER WHEN THIS CRITERIA IS MET.

THE FOLLOWING SHALL BE INSPECTED A MINIMUM OF ONCE A WEEK OR WITHIN 24 HOURS AFTER 0.25 INCHES OF RAINFALL:

1. STABILIZATION MEASURES (ONCE A MONTH IF FULLY STABILIZED).
  2. STRUCTURAL CONTROLS.
  3. DISCHARGE POINTS.
  4. CONSTRUCTION ENTRANCES AND EXITS.
  5. AREAS USED FOR STORAGE OF EXPOSED MATERIALS.
- I. AN INSPECTION FORM SHALL BE COMPLETED FOR EACH INSPECTION. ANY PERMIT VIOLATIONS SHOULD BE NOTED AND CORRECTIVE MEASURES TO BE TAKEN SHALL BE NOTED. IF REVISIONS TO THE SWPPP ARE NEEDED, A REPORT FORM FOR CHANGES IN THE SWPPP SHALL BE COMPLETED AND A COPY SENT TO THE DEVELOPER. THE ORIGINAL SHALL BE KEPT ON-SITE AS DOCUMENTATION OF THE CHANGE. IF THE INSPECTION PASSES, A CERTIFICATION THAT THE FACILITY IS IN COMPLIANCE WITH THE SWPPP AND THE GENERIC PERMIT MUST BE SIGNED BY ONE OF THE FOLLOWING:
1. THE PRINCIPAL EXECUTIVE OFFICER OR RANKING ELECTED OFFICIAL OF THE OPERATOR OF THE SWPPP.
  2. A DULY AUTHORIZED REPRESENTATIVE OF THE PRINCIPAL EXECUTIVE OFFICIAL OF THE OPERATOR OF THE SWPPP.
- J. RETAIN INSPECTION REPORTS AND CERTIFICATIONS FOR AT LEAST THREE YEARS.
- K. INITIATE SITE STABILIZATION MEASURES NO MORE THAN 14 DAYS AFTER CONSTRUCTION ACTIVITIES HAVE TEMPORARILY OR PERMANENTLY CEASED ON ANY MAJOR PORTION OF THE SITE EXCEPT WHEN CONSTRUCTION WILL RESUME WITHIN 21 DAYS.
- L. SIGN AND SUBMIT TO THE DEVELOPER CERTIFICATION THAT CONSTRUCTION AND FINAL STABILIZATION AS DEFINED UNDER PART E OF THE DEVELOPER SECTION OF THE SWPPP HAS BEEN COMPLETED.

M. THE CONTRACTOR IS RESPONSIBLE FOR IMPLEMENTATION OF EACH MEASURE IDENTIFIED IN THE SWPPP AND SHALL PROVIDE DOCUMENTATION CERTIFYING THAT BEFORE CONDUCTING ANY PROFESSIONAL SERVICE IDENTIFIED IN THE SWPPP; THAT UNDER PENALTY OF LAW THAT I UNDERSTAND THE TERMS AND CONDITIONS OF THE GENERIC STORMWATER PERMIT ISSUED PURSUANT TO SECTION 403.0885, F.S., THAT AUTHORIZES THE STORMWATER DISCHARGES ASSOCIATED WITH INDUSTRIAL ACTIVITY FROM THE CONSTRUCTION SITE IDENTIFIED AS PART OF THIS CERTIFICATION.

## EARTHWORK NOTES:

1. THE CONTRACTOR SHALL INSTALL SILT FENCE AND TREE BARRICADES AS SHOWN ON TYPICAL DETAILS. MONROE COUNTY SHOULD BE CONTACTED TO INSPECT SILT FENCE AND TREE BARRICADES PRIOR TO COMMENCEMENT OF EARTHWORK OPERATIONS.
2. UPON ISSUANCE OF CLEARING PERMIT, CONTRACTOR SHALL REMOVE AND DISPOSE OF TREES CALLED FOR SUCH ON PLANS. ALL GROUND VEGETATION AND TOPSOIL WITHIN THE LIMITS OF CONSTRUCTION SHALL BE REMOVED. ANY UNSUITABLE MATERIAL ENCOUNTERED SHALL BE REMOVED TO THE SATISFACTION OF THE GEOTECHNICAL ENGINEER. ALL TOPSOIL REMOVED FROM THE BUILDING AND PAVEMENT AREAS SHALL BE STOCKPILED AND USED LATER IN LANDSCAPED AREAS. ALL ORGANIC SOILS/DEBRIS SHOULD BE REMOVED, SEE ORGANIC SOILS REMOVAL NOTES.
3. AFTER CLEARING OPERATIONS, THE EXPOSED SUBGRADE SHOULD BE EVALUATED AND PROOF ROLLED AS DIRECTED BY THE GEOTECHNICAL ENGINEER. PROOF ROLLING SHALL CONSIST OF COMPACTION WITH A LARGE-DIAMETER, HEAVY VIBRATORY DRUM ROLLER. OBSERVATION SHOULD BE MADE TO IDENTIFY ANY AREAS OF YIELDING SOILS THAT MAY REQUIRE OVER EXCAVATION AND REPLACEMENT, AS DETERMINED BY THE GEOTECHNICAL ENGINEER.

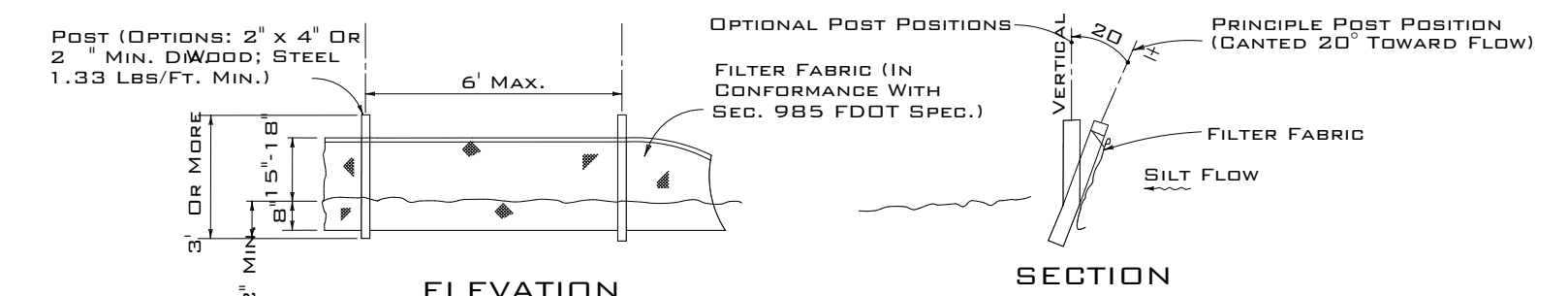

TYPE III SILT FENCE

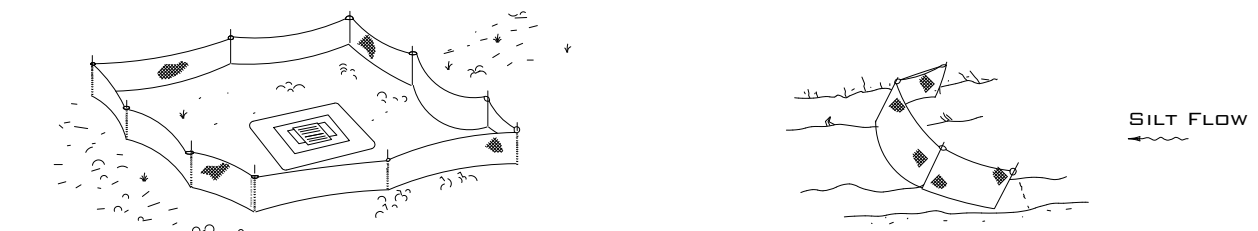

DO NOT DEPLOY IN A MANNER THAT SILT FENCES WILL ACT AS A DAM ACROSS PERMANENT FLOWING WATERCOURSES. SILT FENCES ARE TO BE USED AT UPLAND LOCATIONS AND TURBIDITY BARRIERS USED AT PERMANENT BODIES OF WATER.

## SILT FENCE APPLICATIONS

## REFERENCED SPECIFICATIONS (LATEST EDITIONS):

1. FLORIDA DEPARTMENT OF TRANSPORTATION STANDARD SPECIFICATION AND INDEX.
2. CITY OF KEY WEST LAND DEVELOPMENT REGULATIONS.
3. F.D.E.P. REQUIREMENTS AND STANDARDS FOR WATER AND WASTEWATER CONSTRUCTION AND TESTING.
4. FBC 6TH EDITION (2017)

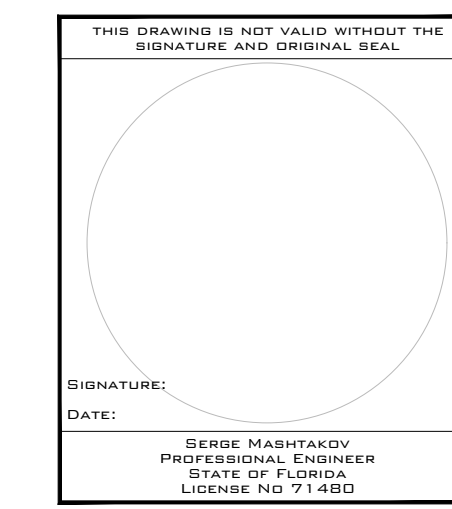

REV. DESCRIPTION	BY	DATE
STATUS: FINAL		
<b>ARTIBUS DESIGN</b> ENGINEERING AND PLANNING		
ARTIBUS DESIGN 3710 N. ROOSEVELT BLVD KEY WEST, FL 33040 (305) 324-3512 WWW.ARTIBUSDESIGN.COM CA # 30825		
CLIENT:	CITY OF KEY WEST ENGINEERING DEPARTMENT 1300 WHITE ST. KEY WEST, FL 33040	
PROJECT:	REST BEACH PAVILLIONS	
SITE:	REST BEACH, ATLANTIC BLVD KEY WEST, FL 33040	
TITLE:	COVER/NOTES	
SIGNATURE:		
DATE:	DATE:	DATE:
1907-20	0113-21	05-100
DESIGN:	DESIGN:	DESIGN:
SAH	SAH	SAH
1	1	1



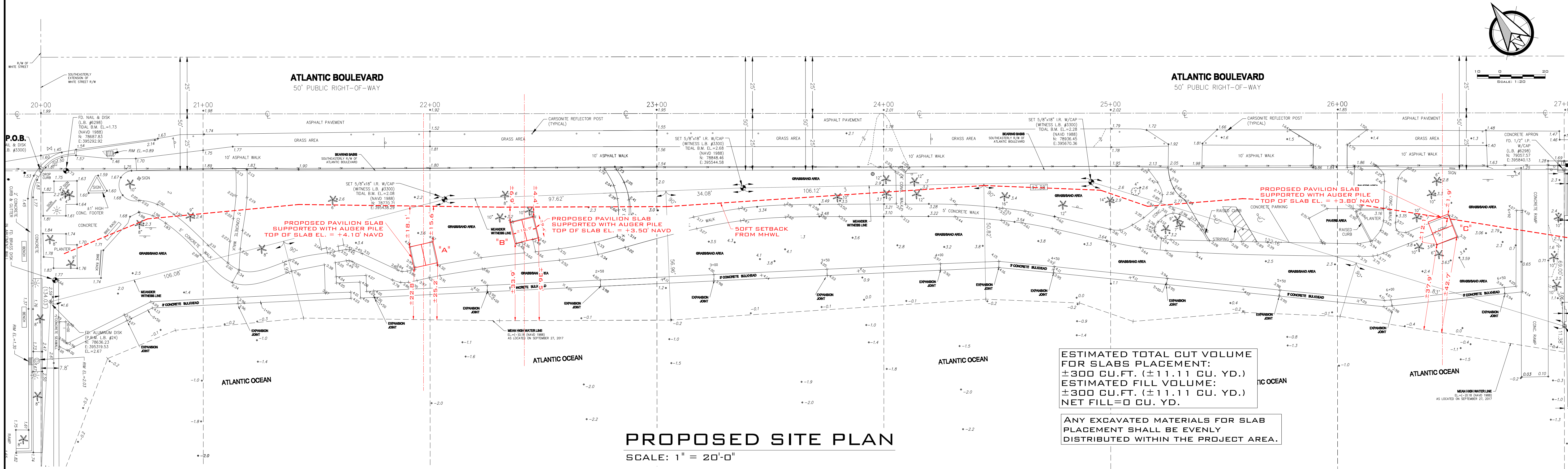
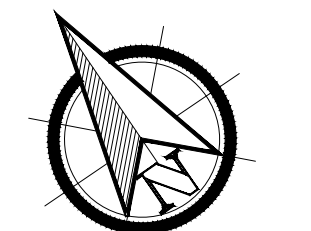

ESTIMATED TOTAL CUT VOLUME FOR SLABS PLACEMENT:  
 ±300 CU.FT. (±11.11 CU. YD.)  
 ESTIMATED FILL VOLUME:  
 ±300 CU.FT. (±11.11 CU. YD.)  
 NET FILL=0 CU. YD.

ANY EXCAVATED MATERIALS FOR SLAB PLACEMENT SHALL BE EVENLY DISTRIBUTED WITHIN THE PROJECT AREA.

**PROPOSED SITE PLAN**  
 SCALE: 1" = 20'-0"

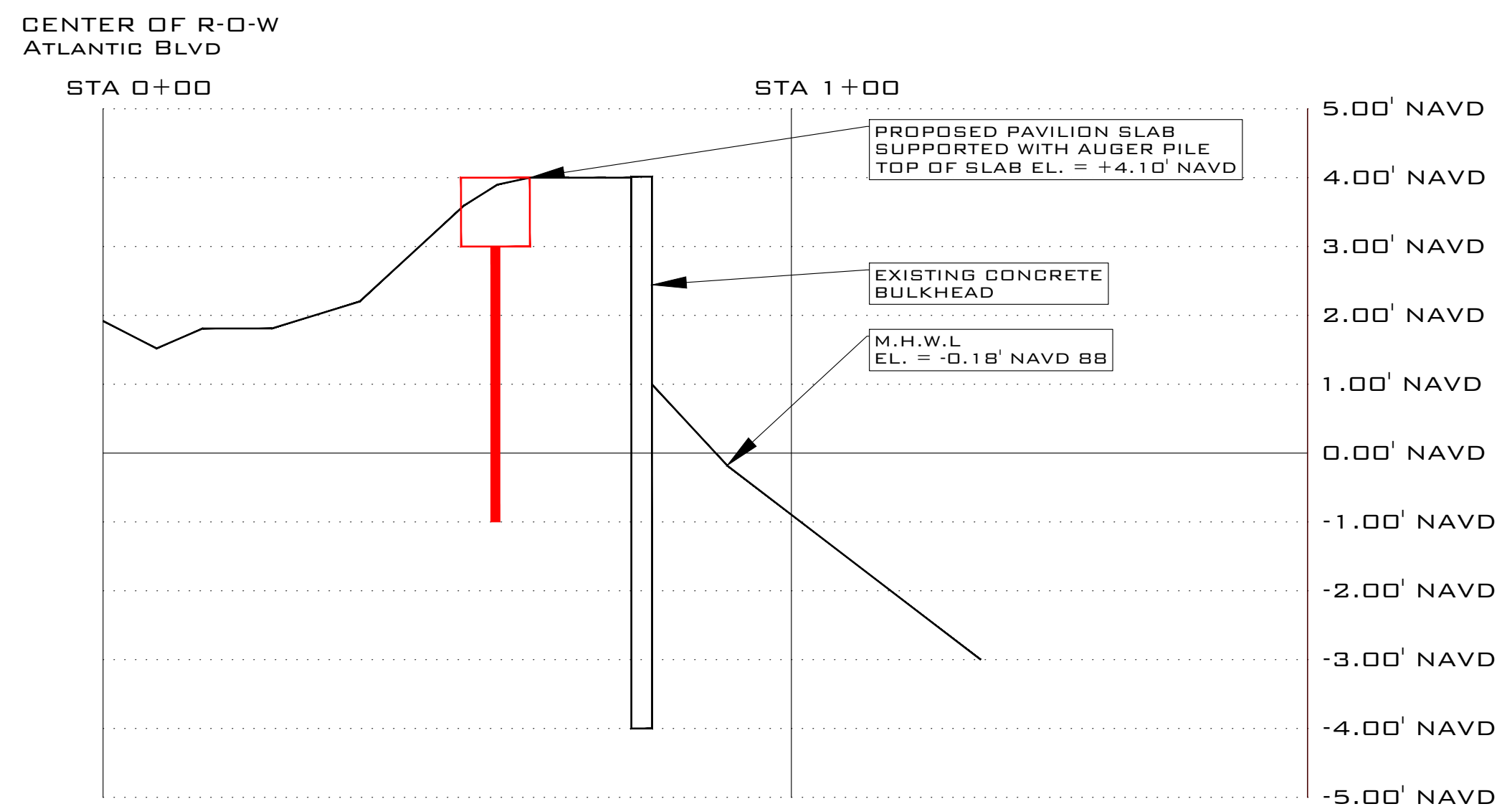

**CUT/FILL PROFILE PAVILION "A"**  
 SCALE HORIZONTAL: 1" = 20'-0"  
 SCALE VERTICAL: 1" = 2'-0"

ESTIMATED CUT VOLUME FOR SLAB PLACEMENT:  
 ±100 CU.FT. (±3.70 CU. YD.)  
 ESTIMATED FILL VOLUME:  
 ±100 CU.FT. (±3.70 CU. YD.)  
 NET FILL=0 CU. YD.

ANY EXCAVATED MATERIALS FOR SLAB PLACEMENT SHALL BE EVENLY DISTRIBUTED WITHIN THE PROJECT AREA.

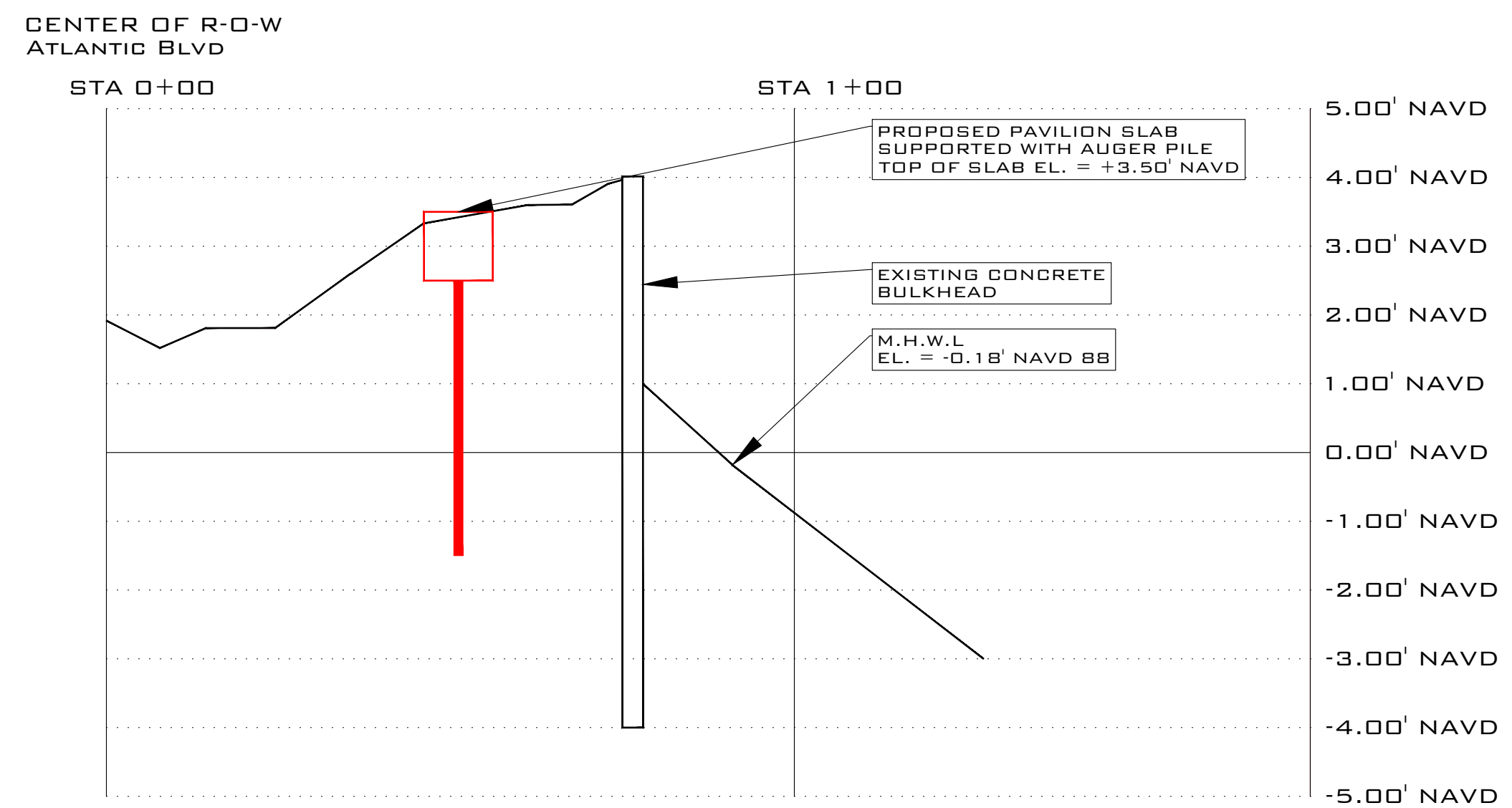

**CUT/FILL PROFILE PAVILION "B"**  
 SCALE HORIZONTAL: 1" = 20'-0"  
 SCALE VERTICAL: 1" = 2'-0"

ESTIMATED CUT VOLUME FOR SLAB PLACEMENT:  
 ±100 CU.FT. (±3.70 CU. YD.)  
 ESTIMATED FILL VOLUME:  
 ±100 CU.FT. (±3.70 CU. YD.)  
 NET FILL=0 CU. YD.

ANY EXCAVATED MATERIALS FOR SLAB PLACEMENT SHALL BE EVENLY DISTRIBUTED WITHIN THE PROJECT AREA.

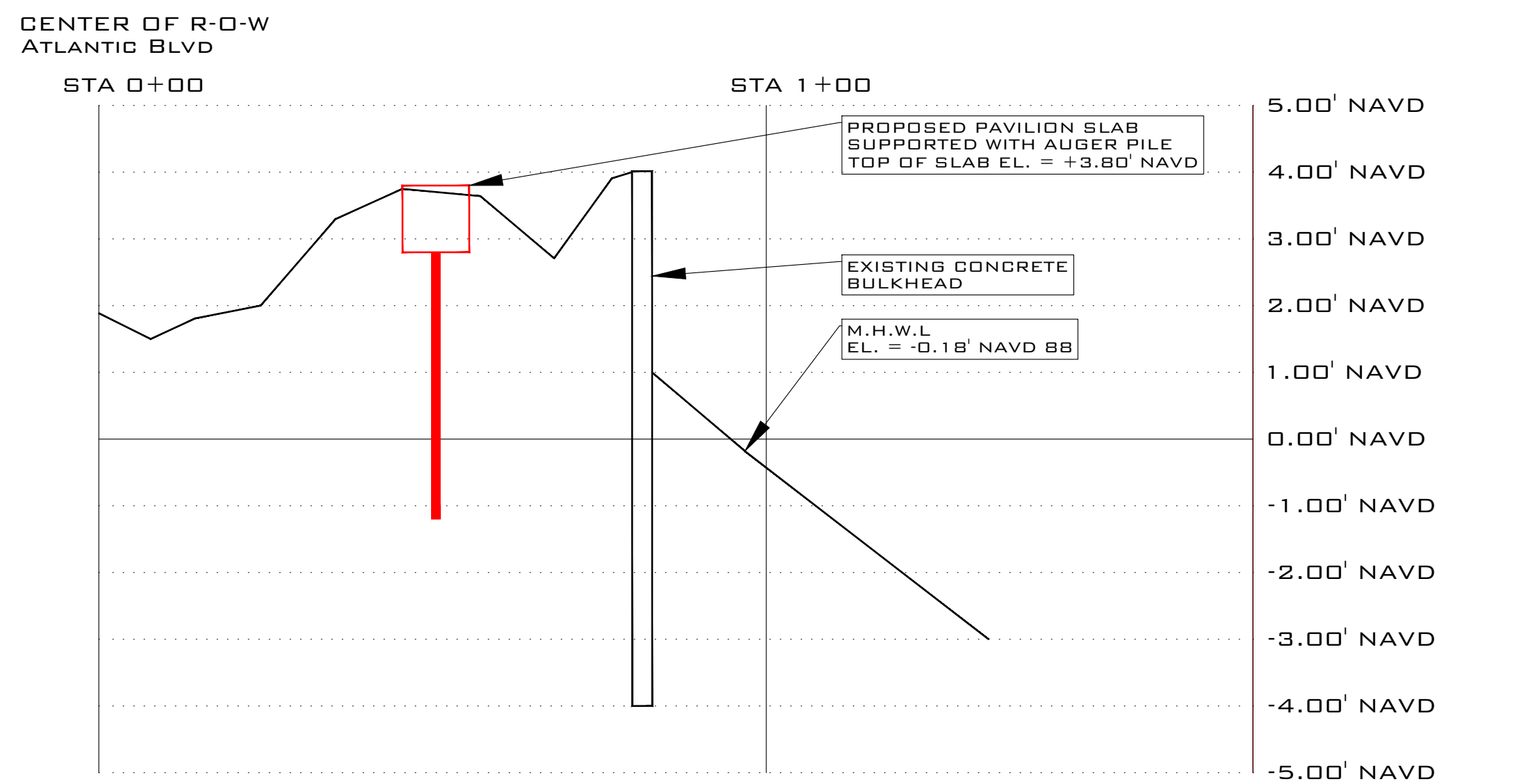

**CUT/FILL PROFILE PAVILION "C"**  
 SCALE HORIZONTAL: 1" = 20'-0"  
 SCALE VERTICAL: 1" = 2'-0"

ESTIMATED CUT VOLUME FOR SLAB PLACEMENT:  
 ±100 CU.FT. (±3.70 CU. YD.)  
 ESTIMATED FILL VOLUME:  
 ±100 CU.FT. (±3.70 CU. YD.)  
 NET FILL=0 CU. YD.

ANY EXCAVATED MATERIALS FOR SLAB PLACEMENT SHALL BE EVENLY DISTRIBUTED WITHIN THE PROJECT AREA.

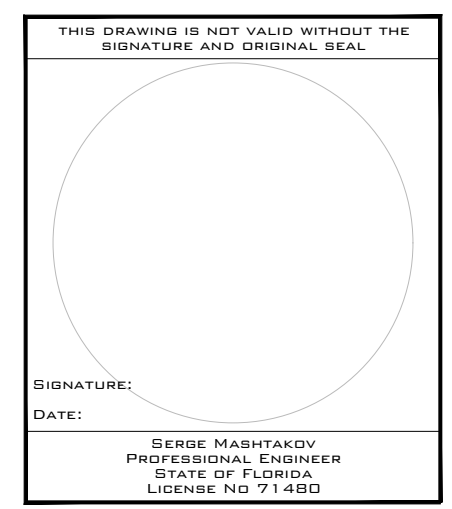

REV. DESCRIPTION	BY	DATE
STATUS: FINAL		
<b>ARTIBUS DESIGN</b> ENGINEERING AND PLANNING		
ARTIBUS DESIGN 3710 N. ROOSEVELT BLVD KEY WEST, FL 33040 (305) 304-3512 WWW.ARTIBUSDESIGN.COM CA # 30825		
PROJECT:	REST BEACH PAVILIONS	
SITE:	REST BEACH, ATLANTIC BLVD KEY WEST, FL 33040	
TITLE:	SITE PLAN CUT/FILL PROFILES	
DATE:	DATE PLOTTED:	SCALE:
1907-20	01/11/21	1" = 2'-0"
DESIGNED BY:	CHECKED BY:	DATE:
AM SHOWN	DM	01/11/21
PROJECT NO.:	PROJECT NO.:	PROJECT NO.:
1907-20	E-101	1