



Community Redevelopment Area Application for Tax Increment Appropriation 2012 Allocation

Applications for funding are accepted between Tuesday, July 5, 2011 and Friday, September 30, 2011. By law funding for the Community Redevelopment Agency occurs after January 1. The attached Community Redevelopment Agency Use of Tax Increment Funding Guidelines includes additional information to assist in the application process.

- A. CRA LOCATION: Which Community Redevelopment Area (CRA) subarea is the project located within? **Check one:** Bahama Village Subarea
 Caroline Street Corridor Subarea

B. PROJECT NAME:

C. PROJECT LOCATION/ADDRESS:

- D. APPLICANT (*PLEASE EXECUTE ATTACHED AUTHORIZATION FORMS*)

Entity

Authorized Representative

Role or Capacity of Authorized Representative

Address

Telephone Number

Cellular Number

E-Mail Address



E. PROJECT INFORMATION

What type of project is proposed: **Check one:** Construction/Restoration Program

Provide a brief description of the project:

Change order request for 2010 TIF Allocation Project - Refer to Attachment E for Project Description.

If a Construction/Restoration Project, please provide information that fully describes the physical boundaries of the proposed project as follows:

map(s)

deeds(s)

boundary survey

Monroe County Property Appraiser data for the site (<http://www.mcpafl.org>)

If a Program, please fully describe the population served by the program and the address of the program facility location on a separate sheet of paper. Please attach authorization from the property owner for the proposed program facility location.

Facility location authorization

F. OWNERSHIP AND LEGAL STRUCTURE

Provide the full name(s) of the person(s) or entity(s) expected to own (or operate if a program) the project and fully describe their legal structure (i.e. principals, ownership interests, relationship to parent organization, subsidiaries, etc.). Include a complete list of officers, directors and board members (as applicable) associated with entity who requested the appropriation. Attach additional information if necessary.

Union Lodge #47 - Bernard Thurston

Is the facility or program open to the public regardless of the individual's race, color, sex, gender identity or expression, religion, disability, national origin, ancestry, sexual orientation, marital status, parental status, or source of income and is there a charge associated with public use or entry to the facility or program? Please describe if necessary or explain if facility or programs have limitations to access. Attach additional information if necessary.

The public is able to use the facility by contacting the organization.



G. PREAPPLICATION MEETING

A pre-application with the City Planner and Historic Preservation Planner is required prior to application submittal. Please provide the following pre-application meeting dates:

9/30/2011 Planning Department

9/30/2011 Historic Preservation Planner

H. PROJECT BUDGET

Note: Applicants are encouraged to consider the total amount available for TIF funding in 2012 relative to their project request.

1. Is funding requested for multiple phases (over more than one funding cycle?)
[X] yes [] no

2. Project Cost for 2012 \$8,078.70

Total Project Cost \$106,078.70 (if multiphase, for all years)

3. Amount of TIF Funding Requested for 2012 \$4,078.70

Total Amount of TIF Funding Requested \$94,078.80 (if multiphase, for all years)

4. Total Amount of matching funds provided for 2012 \$0.00

Total Amount of matching funds provided \$12,000.00 (if multiphase, for all years)

Describe the source and amount of matching funds Labor by Union Lodge and services by mbi | k2m

5. Attach a detailed budget for the project describing each key element and estimated costs (if multiphase, for all years)

[X] Detailed budget attached

I. PROJECT SCHEDULE

Please provide a schedule for approvals, construction and implementation of proposal, including multiyear phasing if relevant.

[X] Schedule attached

J. GREEN FEATURES

Although not specifically required by Chapter 163, part 3, Florida Statutes of the Community Redevelopment Act, it is important to encourage the concept of going green within the context of implementation of a community redevelopment. Going green in this instance means conscious attempts to reduce overall negative environmental impacts by individuals, businesses and government. Community redevelopment activities including the appropriation and use of tax increment when reasonably feasible should



consider a focus on conserving the earth's resources, energy efficient activities, production of consumption of energy, use of sustainable materials, elimination of waste, compliance with environmental regulations and the use of environmentally friendly products, equipment and services. In this context green services are earth friendly, ethically produced and made energy efficient and employ the use recyclable materials. Please indicate how this application will promote green services. **Projects with green features will be given priority for funding.**

Green Features response attached

K. CERTIFICATION

By making this application, Applicant certifies that he or she has read Section 163.340(9), Florida Statutes (the definition of "community redevelopment") and the City's Community Redevelopment Plan (including any amendment or restatement thereof, and understands that any funding pursuant to application must be consistent with the City's community redevelopment policy objectives and City of Key West guidelines and procedures.)

The undersigned has read this form, authorized its preparation and, under penalty of perjury, hereby certifies that, to the best of his or her knowledge and belief that the information provided is true, accurate and complete. Applicant understands that any appropriation is subject to available funds and if requested agrees to provide any and all additional information in a timely fashion as requested by the CRA or City.

Chapter 837.06 Florida Statutes - False Official Statements - Whoever knowingly makes a false statement in writing with the intent to mislead a public servant in the performance of his or her official duty shall be guilty of a misdemeanor of the second degree punishable as provided for in S. 775.082 or S. 775.083.

Applicant's Signature: Michael B. Ingram Date: 9/29/11

Subscribed and sworn to (or affirmed) before me on Sept. 29 2011 (date) by

Michael B. Ingram
Please Print Name of Affiant

He/She is personally known to me or has presented Florida DL as identification.

Lisa M. McCarthy
Notary's Signature and Seal

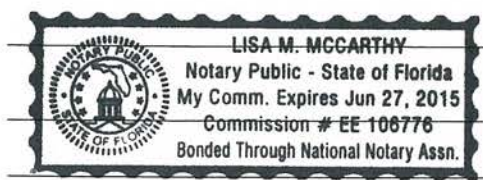

Name of Acknowledger printed or stamped

Title or Rank

Commission Number, if any

Section E
Project Information

ATTACHMENT E

ATTACHMENT E - PROJECT DESCRIPTION and BUDGET

The Union Lodge #47 received funding during the 2010 TIF Allocation cycle for structural stabilization of the roof and reconfiguration of the interior to provide an ADA compliant restroom facility. To date, the work has been completed with final inspection in the coming days. During the course of work, discovery of deteriorated conditions as well as direction by the Building Department Inspector necessitated additional work to be completed that was not in the original scope of work and budget, which was reduced from \$150,000 to \$90,000:

- Replacement of the previously removed exterior egress wood stairs for Life Safety (negotiated within scope)
- New electrical to bring the existing HVAC system into compliance with current code (additional)
- Installation of two restroom exhaust fans as directed by the City's Building Department Inspector (additional)
- Installation of emergency lighting at exterior stairs as directed by Fire Department (additional)

	<u>2010 Allocation</u>	<u>2012 Allocation</u>
The budget per the 2010 TIF Allocation:	\$ 90,000.00	
Matching funds provided by Union Lodge #47	\$ 8,000.00	
Change Order (Additional funding request for 2012 TIF Allocation):		
(refer to attached page from Holtkamp Construction)		\$ 4,078.70
<u>Project Coordination (matching service provided by mbi k2m Architecture)</u>		<u>\$ 4,000.00</u>
Total Project Cost (2010 and 2012 TIF Allocation Cycle):		\$ 106,078.70
Requested Funding for 2012 TIF Allocation		\$ 4,078.70

June 14, 2011

Union Lodge #47
328 Truman Avenue
Key West, Florida 33040
Attn: Aaron Castillo

**Re: Union Lodge #47 – 328 Truman Avenue
Response to Ceiling Fan Request**

Dear Aaron,

We have been in communication with Jerry Curtis regarding installing ceiling fans in the renovated second floor of the Union Lodge project. The installation of ceiling fans was not included in the original scope of work due to the limited budget available to the project. Yesterday, the General Contactor, Electrical Contractor, and I (Jerry Curtis was invited but did not make the meeting) met on site to discuss the possibility of installing 6 new ceiling fans which Jerry is arranging to be donated.

With the level of renovation occurring, the existing electrical system needed to be brought up to current code in all areas that were disturbed, including but not limited to the following:

- Locating light switches adjacent to each door location where their were previously none;
- Rewiring of all the ceiling lights to replace existing wiring that did not meet code;
- Installation of outlets along the counter surface in the catering kitchen;
- Installation of a light at the new egress stair with photocell;
- Rewiring of the air conditioning system to address a non code compliant existing installation.

The above items were not anticipated to be part of the work at the time of bidding but were discovered once demolition and inspections began. To assist with the limited budget project, both the electrical contractor and general contractor are doing what they can to cover the above costs without additional expense to the project. However, not all costs can be absorbed. In order to cover some of the costs, the proposed concrete sidewalk connecting the new egress stairs to the sidewalk on Truman may be replaced with gravel. Additionally, a change order may be required to cover the rewiring of the air conditioning system.

We understand the Union Lodge would like new ceiling fans installed; however the electrical contractor will need compensation for this work. Should the lodge wish to proceed, they will be responsible for the costs to install the fans. Due to the timing of the project, approval of the expenses will need to be made this week to avoid any delays to the project. If the Lodge would like to proceed, please contact us and we will arrange for a change order to be submitted to you detailing the expense for the work.

Best Regards,

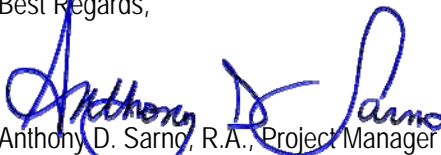
Anthony D. Sarno, R.A., Project Manager

Cc: Holtkamp Construction
File

June 15, 2011

The City of Key West
Building Department
3140 Flagler Avenue
Key West, Florida 33040
Attn: Terry Richardson, Inspector – sent via email to trichard@keywestcity.com

Re: **Union Lodge #47 – 328 Truman Avenue**
Restroom Ventilation and Fresh Air Requirements

Dear Terry,

During the inspections yesterday at the Union Lodge #47 project at 328 Truman Avenue, the following items were noted as not compliant:

- Exhaust ventilation at the restrooms
- Fresh air requirements

For the restrooms, our current design is using the existing exterior windows for natural ventilation to keep the costs to a minimum for the project. Based on our understandings and calculations, we determined the windows to be sufficient to provide the required ventilation per code. Please note the following:

- Florida Mechanical Code 2007, Section 402.2 requires that the minimal openable area to the outdoors shall be four percent of the floor area being ventilated for natural ventilation;
- The restroom windows are identical in size, providing an open area of greater than 18" x 18" or 324 square inches;

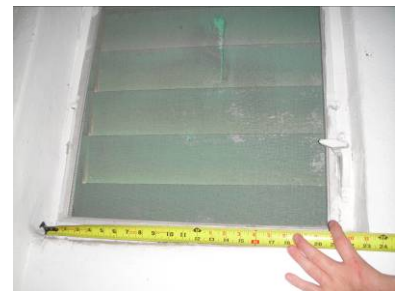

- The floor area of largest of the two restrooms measures 7,572 square inches;
- Four percent of 7,572 square inches equals 302.88 square inches;
- Therefore, the existing windows are compliant with providing the required ventilation for each restroom.

We ask for approval that the existing exterior windows meet the ventilation requirement, and therefore the mechanical exhaust fans as mentioned in the inspection will not be required.

Addressing the fresh air requirements, the existing envelope of the Union Lodge is not fully sealed at window and door openings. We understand that there is sufficient air infiltration through these gaps to meet the fresh air requirements for the renovated areas.

We trust that you concur with our statements. Should you have any additional questions, please do not hesitate to contact me.

Best Regards,

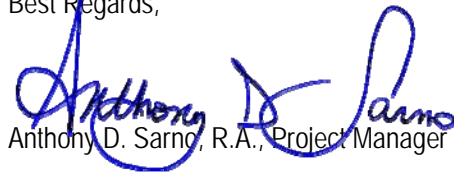
Anthony D. Sarno, R.A., Project Manager

Cc: Holtkamp Construction
File

X:\Jobs\2010\MK-10050 - City of KW - Union Lodge Roof Repair\Admin\Correspondence\Letters\2011.06.15 Letter to Building Department RE Restroom Ventilation and Fresh Air Requirements.doc



RECEIVED

September 30, 2011

KW Planning Dpt

Michael B. Ingram

From: Holtkamp Construction [jholtkamp@bellsouth.net]
Sent: Thursday, April 07, 2011 2:04 PM
To: Michael B. Ingram
Subject: 328 Truman Avenue

Michael,

I spoke with Aaron Castillo, of Key West Mortuary & Cremation Center. He has requested for us to do work around him without moving appliances, furniture, and electrical equipment. Please be advised that I will not be held responsible for any damage(s) if these items are not removed by the funeral home.

Please acknowledge receipt of this.

Thanks,

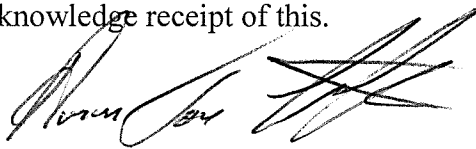

4.7.11

Jordan Holtkamp
Holtkamp Construction
5607 3rd Avenue
Key West, FL 33040
Phone: (305) 294-5399
Fax: (305) 294-7399

4/7/2011

Section F
Ownership & Legal Structure

Verification Form



RECEIVED
September 30, 2011
KW Planning Dpt

Please note, variances are quasi-judicial hearings and it is improper to speak to a Planning Board or Board of Adjustment Member about the variance outside of the hearing.

This form should be completed by the applicant. Where appropriate, please indicate whether applicant is the owner or a legal representative. If a legal representative, please have the owner(s) complete the following page, "Authorization Form."

I, Union Temple Association / Union Lodge #47, being duly sworn, depose and say
Name(s) of Applicant(s)

that: I am (check one) the Owner Owner's Legal Representative for the property identified as the subject matter of this application:

328 Truman Avenue Key West, Fl. 33040
Street Address and Commonly Used Name (if any)

All of the answers to the above questions, drawings, plans and any other attached data which make up this application, are true and correct to the best of my knowledge and belief and that if not true or correct, are grounds for revocation of any action reliant on said information.

Bernard N. Thurston Sr.
Signature of Owner/Legal Representative

Signature of Joint/Co-owner

Subscribed and sworn to (or affirmed) before me on 9/13/10 (date) by Bernard N Thurston Sr. President (name). He/She is personally known to me or has

presented _____ as identification.

Joan Allen Leggett
Notary's Signature and Seal

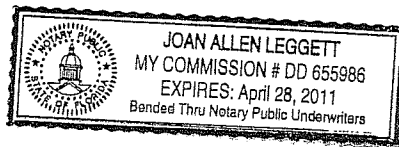

Name of Acknowledger typed, printed or stamped

Title or Rank _____ Commission Number (if any)

Authorization Form



RECEIVED

September 30, 2011

KW Planning Dpt

Please note, variances are quasi-judicial hearings and it is improper to speak to a Planning Board or Board of Adjustment Member about the variance outside of the hearing.

Please complete this form if someone other than the owner is representing the property owner in this matter.

I, Union Lodge #47, Union Temple Association authorize
Please Print Name(s) of Owner(s)

Bernard N. Thurston Sr President

Please Print Name of Representative

to be the representative for this application and act on my/our behalf before the Planning Board.

Bernard N. Thurston Sr

Signature of Owner

Signature of Joint/Co-owner if applicable

Subscribed and sworn to (or affirmed) before me on 9/13/10 (date) by

Bernard N. Thurston Sr President

Please Print Name of Affiant

He/She is personally known to me or has

presented personally known to me as identification.

Joan Allen Leggett
Notary's Signature and Seal

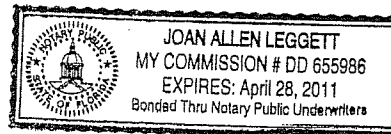

Name of Acknowledger printed or stamped

Title or Rank

Commission Number (if any)

Boundary Survey Map of Lot 1, Square 1, of E.C. Howe's Diagram of Tract 10 of the City of Key West



RECEIVED
September 30, 2011
KW Planning Dpt

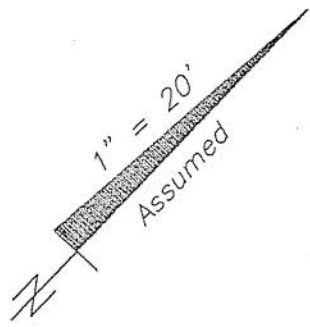

LEGEND

- Set 3/4" Iron Pipe w/cap (6298)
- Found 1/2" Iron Rod (2863)
- ▲ Found Nail (No ID)
- △ Set Nail & Disc (6298)
- (M) Measured
- (R) Record
- (M/R) Measured & Record
- C.B.S. Concrete Block Structure
- R\W Right of Way
- CLF Chain Link Fence
- ⊕ Centerline
- ⊗ Wood Utility Pole
- ⊗ Concrete Utility Pole
- P- Overhead Utility Lines
- (9.0) Spot Grade Elevation (Typical)

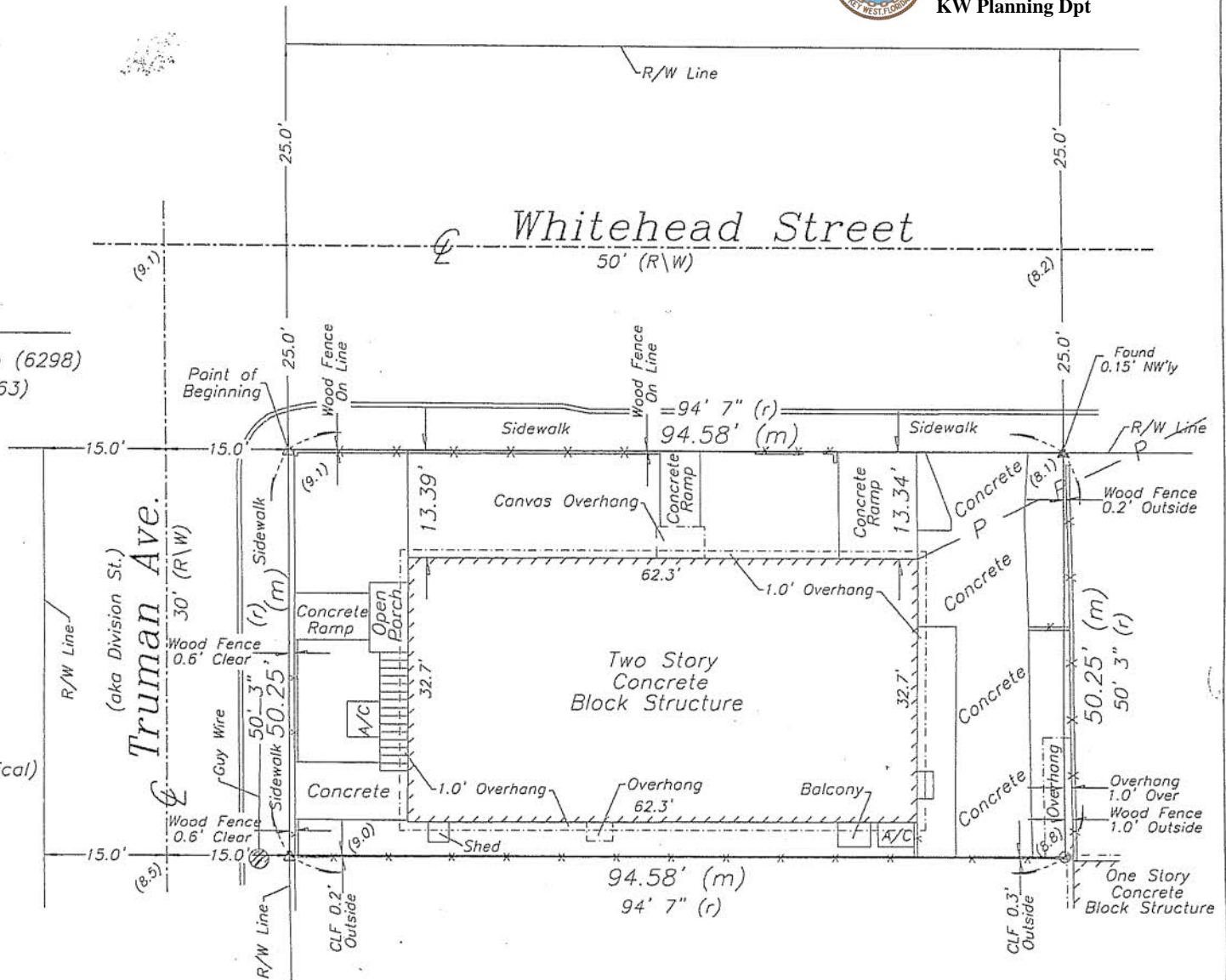

NOTES:

1. The legal description shown hereon was furnished by the client or their agent.
2. Underground foundations and utilities were not located.
3. All angles are 90° (Measured & Record) unless otherwise noted.
4. Street address: 328 Truman Ave., Key West, FL.
5. This survey is not valid without the signature and the original raised seal of a Florida licensed surveyor and mapper.
6. Lands shown hereon were not abstracted for rights-of-way, easements, ownership, or other instruments of record.
7. North Arrow is assumed and based on the legal description.
8. This survey is not assignable.
9. Date of field work: May 6, 2009.
10. Ownership of fences is undeterminable, unless otherwise noted.
11. Adjoiners are not furnished.
12. Elevations are shown in parenthesis and refer to Mean Sea Level N.G.V.D. 1929 Datum.
13. Flood Insurance Rate Map Zone: X; Community # 120168; Panel # 1516; Suffix K; Dated 2/18/05.

BOUNDARY SURVEY OF: Lot One (1), Square One (1) of E.C. Howe's Diagram of Tract Ten (10) of the City of Key West, as per Whitehead's Map—
COMMENCING at the corner of Whitehead and Division Streets, and thence running along Whitehead Street in a SE'ly direction Ninety-four (94) feet and Seven (7) inches; thence at right angles in a SW'ly direction Fifty (50) feet and Three (3) inches; thence at right angles in a NW'ly direction Ninety-four (94) feet and Seven (7) inches; thence at right angles in a NE'ly direction along Division Street Fifty (50) feet and Three (3) inches to the place of beginning.

BOUNDARY SURVEY FOR: Union Lodge;

J. LYNN O'FLYNN, INC.

J. Lynn O'Flynn, PSM
Florida Reg. #6298

May 11, 2009

J. LYNN O'FLYNN, Inc.

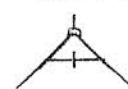

Professional Surveyor & Mapper
PSM #6298

3430 Duck Ave., Key West, FL 33040
(305) 296-7422 FAX (305) 296-2244

Section H
Project Budget

ATTACHMENT E

ATTACHMENT E – PROJECT DESCRIPTION and BUDGET

The Union Lodge #47 received funding during the 2010 TIF Allocation cycle for structural stabilization of the roof and reconfiguration of the interior to provide an ADA compliant restroom facility. To date, the work has been completed with final inspection in the coming days. During the course of work, discovery of deteriorated conditions as well as direction by the Building Department Inspector necessitated additional work to be completed that was not in the original scope of work and budget, which was reduced from \$150,000 to \$90,000:

- Replacement of the previously removed exterior egress wood stairs for Life Safety (negotiated within scope)
- New electrical to bring the existing HVAC system into compliance with current code (additional)
- Installation of two restroom exhaust fans as directed by the City’s Building Department Inspector (additional)
- Installation of emergency lighting at exterior stairs as directed by Fire Department (additional)

	<u>2010 Allocation</u>	<u>2012 Allocation</u>
The budget per the 2010 TIF Allocation:	\$ 90,000.00	
Matching funds provided by Union Lodge #47	\$ 8,000.00	
Change Order (Additional funding request for 2012 TIF Allocation):		
(refer to attached page from Holtkamp Construction)		\$ 4,078.70
<u>Project Coordination (matching service provided by mbi k2m Architecture)</u>		<u>\$ 4,000.00</u>
Total Project Cost (2010 and 2012 TIF Allocation Cycle):		\$ 106,078.70
Requested Funding for 2012 TIF Allocation		\$ 4,078.70

Section I

Project Schedule



ATTACHMENT I

ATTACHMENT I – PROJECT SCHEDULE

The project will receive its final inspection in the coming days. At that time, the project will be complete.

Section J
Green Features



ATTACHMENT J

ATTACHMENT J – GREEN FEATURES

This funding request is for a change order to a previously approved project. The use of Green Features does not apply.

Previous Application



Community Redevelopment Area Application for Tax Increment Appropriation

Applications for funding are accepted on an annual basis between July 1st and September 30th. Complete applications must be submitted by October 31st each calendar year and by law funding for the Community Redevelopment Agency occurs after January 1. By making this application, Applicant certifies that he or she has read Section 163.340(9), Florida Statutes (the definition of "community redevelopment") and the City's Community Redevelopment Plan (including any amendment or restatement thereof, and understands that any funding pursuant to application must be consistent with the City's community redevelopment policy objectives. The attached Community Redevelopment Agency Use of Tax Increment Funding Guidelines include additional information to assist in the application process. Applicants should be especially aware of the Objective Criteria included in those Guidelines as they respond to questions in this application.

Section 163.340(9), Florida Statutes (the definition of "community redevelopment for blighted areas") "Community redevelopment" or "redevelopment" means undertakings, activities, or projects of a . . . municipality, or community redevelopment agency in a community redevelopment area for the elimination and prevention of the development or spread of . . . blight, or for the reduction or prevention of crime, or for the provision of affordable housing, whether for rent or for sale, to residents of low or moderate income, including the elderly, and may include. . . redevelopment within a community redevelopment area . . . that [is] deteriorating and economically distressed, or rehabilitation or conservation in a community redevelopment area, or any combination or part thereof, in accordance with a community redevelopment plan and may include the preparation of such a plan.

A. APPLICANT

1. Name UNION LODGE # 47 (294-3069) (BERNARD THURSTON)

Address 328 TRUMAN AVENUE

Telephone Number 90 MBI-K2M ARCH. 292-7722

Facsimile Number 292-2162

E-Mail Address MINORAM@MBI-K2M.COM

2. If you are an entity provide a description of your business or organization. Attach supporting information and materials if available.

B. PROJECT INFORMATION

1. For: (circle one)

(a) Bahama Village Subarea (b) Caroline Street Corridor Subarea – *Note: Applications for this subarea will begin in 2010 for 2011 Appropriations*

For: (circle one)

(a) New Development (b) Redevelopment (c) Rehabilitation
(d) Infrastructure (e) Programs

2. Project Title

Provide a project title for your community redevelopment financing request project or program.

3. Summary Project Description

Provide a brief description and background information on your community redevelopment project:

4. Evaluation Criteria

Identify which Objectives and Implementing Policies from the Plan the proposal complies with and why.



5. Location and Project Boundaries

Provide information that fully describes and illustrates the location and boundaries of the proposed project. Include map(s), legal description(s) and boundary survey, if available, property tax identification numbers, address, and area (in sq. ft. or acres). Provide photographs of the site where work is proposed. You may attach additional information.

CORNER TRUMAN & WHITENEAD - BUILDING CONFIGURATION & SITE WILL NOT CHANGE.

6. Ownership and Legal Structure

Provide the full name(s) of the person(s) or entity(s) expected to own the project, if the project will not be owned by the City, and fully describe their legal structure (i.e. principals, ownership interests, liability, relationship to parent organization, subsidiaries, etc.). Before any funding each applicant will be required to provide federal and state tax identification numbers (or a social security number if the applicant is an individual without a tax I.D. number). Please note that a restrictive covenant may be required by the City of Key West for your project.

UMDN LODGE #47 - BERNARD THURSTON.

7. Detailed Project Description

Provide a complete description of the proposed community redevelopment project. If funding is required in phases, then provide information for cost and funding requests for each phase as well as the total project. Please address each applicable category below.

- a. Describe who has ownership and/or control of the project site.
- b. Describe the type of project (retail, office, rental housing, home ownership, infrastructure, program, etc.)
- c. Indicate whether the project is new construction or rehabilitation/renovation.
- d. Description of structures which will need to be demolished.
- e. Description of owners/tenants who will need to be relocated.

✓ HARC Planner 10/19/09 NO OBJECTIONS OR ISSUES

b. Zoning District: Please indicate project zoning district(s) and identified planning approvals necessary for the project

HMDR

c. HARC Issues: Please identify HARC issues and required approvals necessary for the project

NO CHANGES TO EXTERIOR - PHASE I COMPLETED AS APPROVED.

9. Project Funding Budget

Provide an overall budget for project construction or program operation. Information should be provided as an attachment to the application. Include the following:

a. Funding Sources – During Construction Period: Provide a general budget for construction of the project. This budget should include a listing of all sources of funds, including total project cost, amount requested, amount provided by applicant and the source of funds provided by applicant.

b. Funding Uses - Order of magnitude cost estimate: Submit an order of magnitude cost estimate for use of funds. A cost estimate prepared by a Florida architect or engineer is preferred for construction-related projects. Cost estimates for programs should include a breakdown between labor and materials. If project is phased, please specify annual allocation needed.

For each “source” of funds (debt, equity, public assistance, etc.) detail the status of the funding source and the applicable construction or program financing terms/details.

Source	Uses (Cost)
TIF	
MATCHING	PRINTING \$ 8,000

10. Project Schedule

Schedule for approvals, construction and implementation of proposal, including multiyear phasing if relevant. The schedule should address the applicable procedural requirements as included in the Use of Tax Increment Guidelines.

SINGLE YEAR FUNDING

C. CERTIFICATION

The undersigned has read this form, authorized its preparation and, under penalty of perjury, hereby certifies that, to the best of his or her knowledge and belief that the information provided is true, accurate and complete. Applicant understands that any appropriation is subject to available funds and if requested agrees to provide any and all additional information in a timely fashion as requested by the CRA or City.

Chapter 837.06 Florida Statutes – False Official Statements – Whoever knowingly makes a false statement in writing with the intent to mislead a public servant in the performance of his or her official duty shall be guilty of a misdemeanor of the second degree punishable as provided for in S. 775.082 or S. 775.083.

Applicant: Bernard Thurston

Date: 10/27/09

Subscribed and sworn to (or affirmed) before me on October 29, 2009 (date) by

Please Print Name of Affiant

He/She is personally known to me or has presented _____ as identification.

Joan Allen Leggett
Notary's Signature and Seal

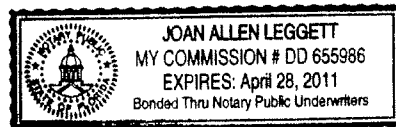

Name of Acknowledger printed or stamped

Title or Rank

Commission Number, if any

October 19, 2009

Union Lodge #47 – Structural stabilization of roof and addition of ADA compliant bathroom facility on 2nd level

Phase II of Historic Lodge #47 Access Program

Phase I accomplished – installation of ADA compliant lift meeting HARC and City code requirements

Phase I(a) improvements to access stairs by replacement of non-compliant railing system (underway)

Phase II

Correction of roof framing / structure currently exhibiting failure, through the majority of its length. Deflection has potential of placing pressure on exterior walls and causing failure of supporting elements, endangerment of occupants within both levels of the existing structure. Failure could also cause unsafe condition at the intersection of Whitehead Street and Truman Avenue – a critical and heavily traffic area within the city.

ADA complaint restroom: Current facility does not meet ADA standards. Replacement of toilet facilities to meet code allows second floor hall to be utilized independently of first floor business, furthering intent of Phase I vertical lift.

Estimated Costs:

Architecture and Engineering / Construction management \$ 20,000

1 Removal / relocation of AC runs to allow removal of ceiling surface and provide access to structural elements.

- a. Phased repositioning of existing rafters; replacement / reinforcement of existing – installation of collar ties.
- b. Reinsulate ceiling area
- c. Replacement of AC distribution system
- d. New ceiling surface / painting
- e. Install lighting

Estimated Cost \$ 115,000
32.7 x 62.3 = 2037 s.f. @ \$56.46

2 Replacement of non-compliant toilet facility

- a. Demolition / disposal
- b. New walls / plumbing / electric / finish
- c. Provide / insure path to toilet facility and ADA lift on exterior

Estimated Cost \$ 17,000

TOTAL ESTIMATED COST \$ 152,000

Request for Additional Information



THE CITY OF KEY WEST

Post Office Box 1409 Key West, FL 33041-1409 (305) 809-3700

October 25, 2011

VIA ELECTRONIC MAIL

Mr. Michael Ingram, AIA
mbi/k2m Architecture, Inc.
1001 Whitehead Street, Suite 101
Key West, Florida 33040

**RE: Application for Tax Increment Financing
Union Lodge No. 47
Request for Additional Information and Clarification**

Dear Mr. Ingram:

The City is in receipt of your timely submitted application for the Union Lodge No. 47. Staff has conducted a preliminary review of the application and is requesting the following additional information or clarification regarding the submitted materials:

- Clarify the matching funds reflected in the Project Budget, what portions of the project were considered matching. Provide a budget for the matching \$4,000 contribution from mbi/k2m Architecture;
- Clarify what current the budget request is for (overage from previous phase) and provide the previous budget showing the overages;
- Clarify how the request is eligible for TIF funding and how the request relates to the CRA Plan requirements;
- Provide a new Authorization and Verification forms that are notarized and up to date;
- Provide description of Green Features.

This additional information is requested by November 2, 2011.

Your project presentation is scheduled before the Bahama Village Redevelopment Advisory Committee at their regularly scheduled meeting on Thursday, November 3, 2011, starting at 5:30 p.m. Please be prepared to describe the key aspects of your project in 10 minutes or less and to answer questions that may be posed by the board. In addition, staff or board members may have additional information or clarification requests during the review period. The Bahama Redevelopment Advisory Committee is expected to meet on December 1, 2011, to recommend funding allocations.

October 25, 2011

Page 2

Please do not hesitate to contact me with any questions or comments.

Sincerely,

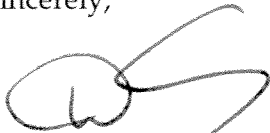
A handwritten signature in black ink, appearing to be "DL Craig", written in a cursive style.

Donald Leland Craig, AICP
Planning Director

Xc: Shawn Smith, City Attorney
Mark Finigan, Assistant City Manager
CRA File

Amended Application Information



November 2, 2011

The City of Key West
PO Box 1409
Key West, Florida 33041
Attn: Don Craig, Planning Director – sent via email dcraig@keywestcity.com

RE: ADDITIONAL INFORMATION REQUEST
TIF APPLICATION 2012 ALLOCATION
UNION LODGE #47

Dear Don Craig,

mbi | k2m is in receipt of your letter dated October 25, 2011 requesting additional information and clarification for the aforementioned project. The comments and our responses in bold are as follows:

Item 1: Clarify the matching funds reflected in the Project Budget, what portions of the project were considered matching. Provide a budget for the matching \$4,000 contribution from mbi | k2m Architecture

Response: *Two matching funds are identified in the project budget; one for the 2010 Allocation for work to be performed by the Union Lodge members and the second for Design Professional Services performed by our office. The \$4,000 contribution includes our time in coordinating with the Contractor to minimize the cost overages to the project through design solutions in the field and in preparation and coordination of this 2012 TIF Allocation Application. More than 40 hours have been spent to these efforts and the \$4,000 match reflects a reduced hourly rate for our staff.*

Item 2: Clarify what current the budget request is for (overage from previous phase) and provide the previous budget showing overages

Response: *This request is to compensate the contractor for work he has performed in order to complete the project that were not anticipated in the original project budget. This includes installation of an emergency lighting at the exterior stairs to meet requirements by the Fire Department, installation of restroom exhaust fans to comply with the City Inspector's request, and upgrades to electrical work for the existing HVAC system to bring it into compliance with current electrical codes.*

During the design phase for the project, it was discovered that a second means of egress was required from the second floor to meet current codes. This required the reconstruction of an exterior wood stair on the side of the building where a stair previously existed. The project's contractor, Holtkamp Construction, was able to accommodate this extra scope within the original 2010 TIF Allocation budget. As a result, this additional budget request is a minimal increase of \$4,078.70 to the original \$90,000 2010 Allocation.

Item 3: Clarify how the request is eligible for the TIF funding and how the request relates to the CRA Plan requirements

Response: *This application is to request additional funding to cover the additional project costs during construction. As a result, this 2012 Allocation request does not specifically relate to the CRA Plan. The 2010 Allocation request, however, relates to the CRA Plan as follows:*

- Section 4.04 item A – The stabilization of the roof helps to maintain the unique character of the Bahama Village subarea;
- Section 4.04 item E – Repairing the building's roof structure provides for continued use of a the facility by the community, thus embracing and supporting the historic fabric of Key West;
- Section 4.04 item K – The addition of the second means of egress stairs and stabilization of the roof emphasize and provide for a safe environment;
- Appendix B – Stabilization of the roof helps to prevent the deterioration of this structure.

Item 4: Provide a new Authorization and Verifications forms that are notarized and up to date

Response: Please see enclosed Authorization and Verification forms, signed and notarized.

Item 5: Provide description of Green Features

Response: The purpose of this TIF Allocation request is to request additional funding to cover the additional costs to the project, which has been completed. Green Features are not applicable to this request, however during the structural stabilization repairs for the roof under the 2010 Allocation, new insulated HVAC ductwork was installed which will help reduce the energy consumed to cool the facility and full ceiling insulation was installed to be continuous and tight. Water reduction plumbing fixtures have been provided and an energy efficient hot water tank. Please note that Green Features were not a requirement for the 2010 Allocation.

We trust that our statements answer your questions. Should you have any questions please do not hesitate to contact our office.

Very Truly Yours,

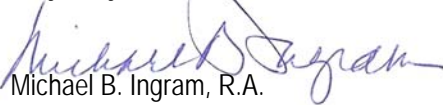
Michael B. Ingram, R.A.
Director of Company

Attachments: Signed Verification Form
Signed Authorization Form

Cc: Bernard Thurston, President Union Lodge #47
file



City of Key West Planning Department

Verification Form

(Where Authorized Representative is an entity)

I, Bernard N. Thurston, Sr., in my capacity as President
(print name) *(print position; president, managing member)*

of Union Temple Association / Union Lodge #47
(print name of entity serving as Authorized Representative)

being duly sworn, depose and say that I am the Authorized Representative of the Owner (as appears on the deed), for the following property identified as the subject matter of this application:

328 Truman Avenue, Key West, Florida 33040
Street Address of subject property

All of the answers to the above questions, drawings, plans and any other attached data which make up the application, are true and correct to the best of my knowledge and belief. In the event the City or the Planning Department relies on any representation herein which proves to be untrue or incorrect, any action or approval based on said representation shall be subject to revocation.

Bernard Thurston
Signature of Authorized Representative

Subscribed and sworn to (or affirmed) before me on this 10/31/11 by
date

Bernard Thurston
Name of Authorized Representative

He/She is personally known to me or has presented *known to me* as identification.

Leonard A. Johnson
Notary's Signature and Seal



Name of Acknowledger typed, printed or stamped

Commission Number, if any



City of Key West Planning Department

Authorization Form (Where Owner is a Business Entity)

Please complete this form if someone other than the owner is representing the property owner in this matter.

I, Bernard N. Thurston, Sr. as
Please Print Name of person with authority to execute documents on behalf of entity

President of Union Temple Association / Union Lodge #47
Name of office (President, Managing Member) *Name of owner from deed*

authorize Michael B. Ingram - mbi | k2m Architecture, Inc.
Please Print Name of Representative

to be the representative for this application and act on my/our behalf before the City of Key West.

Bernard Thurston
Signature of person with authority to execute documents on behalf on entity owner

Subscribed and sworn to (or affirmed) before me on this 10/31/11 by
date

Bernard Thurston
Name of Authorized Representative

He/She is personally known to me or has presented *known to me* as identification.

Leonard A. Johnson
Notary's Signature and Seal



Name of Acknowledger typed, printed or stamped

Commission Number, if any