

Historic Architectural Review Commission

Staff Report Item 6b

Meeting Date: May 27, 2014

Applicant: Donald Beck, Architect and owner

Application Number: H14-01-0579

Address: #2 Gecko Lane

Description of Work: Demolition of non-historic back addition.

Building Facts: The main structure in the site was originally a one story frame vernacular house listed as a contributing resource in the surveys. The house was built ca. 1935. The house has been extremely altered by the construction of side and two story additions.

Ordinance and Guidelines Cited in Review: Demolition of non-historic and non-contributing structures, Sec. 102-217 (2) of the Land Development Regulations.

Staff Analysis

The Certificate of Appropriateness proposes the demolition of rear attached addition that staff has opined that they are non-historic additions.

Consistency with Guidelines and Ordinance for Demolition

It is staff's opinion that the proposed demolition of a non-historic structure will have no effect in the existing house and its site. The applicant has submitted plans including how the built back will look and will relate to the historic house.

It is staff's opinion that the element that is proposed to be demolished is not contributing to the house or will be deemed contributing in a near future. The Commission should consider the demolition request since it is consistent with preservation guidelines and with Sec. 102-217 -218 of the Land Development Regulations. If approved, this review will be the first and only review for a demolition request.

Application

AK 1003106



CITY OF KEY WEST
BUILDING DEPARTMENT
CERTIFICATE OF APPROPRIATENESS 31-2014 010579
APPLICATION # _____

OWNER'S NAME: **Donald Beck & Lawrence Eynon** DATE: **03/25/14**

OWNER'S ADDRESS: **550 Liberty Hill, Cincinnati, OH 45202** PHONE #: **513-651-5550**

APPLICANT'S NAME: **Donald Beck** PHONE #: **513-651-5550**

APPLICANT'S ADDRESS: **550 Liberty Hill, Cincinnati, OH 45202**

ADDRESS OF CONSTRUCTION: **2 Gecko Lane, Key West, FL 33040** # OF UNITS: **1**

THERE WILL BE A FINAL INSPECTION REQUIRED UNDER THIS PERMIT

DETAILED DESCRIPTION OF WORK:
Removal of a one story non-original 194 s.f. bedroom and full bath addition. Construction of a 4.5'x20' rear extension of the original structure and a one story, 1 bedroom, 1 full bath addition. The new additions total 448 s.f.

Chapter 837.06 F.S.-False Official Statements – Whoever knowingly makes a false statement in writing with the intent to mislead a public servant in the performance of his or her official duty shall be guilty of a misdemeanor of the second degree punishable as provided for in s. 775.082 or 775.083

This application for Certificate of Appropriateness must precede applications for building permits, right of way permits, variances, and development review approvals. Applications must meet or exceed the requirements outlined by the Secretary of the Interior's Standards for Rehabilitation and Key West's Historic Architectural Guidelines.

Once completed, the application shall be reviewed by staff for completeness and either approved or scheduled for presentation to the Historic Architectural Review Commission at the next available meeting. The applicant must be present at this meeting. The filing of this application does not ensure approval as submitted.

Applications that do not possess the required Submittals will be considered incomplete and will not be reviewed for approval.

Date: 03/25/14

Applicant's Signature: *Donald Beck*

Required Submittals

<input checked="" type="checkbox"/>	TWO SETS OF SCALED DRAWINGS OF FLOOR PLAN, SITE PLAN AND EXTERIOR ELEVATIONS (for new buildings and additions)
<input type="checkbox"/>	TREE REMOVAL PERMIT (if applicable)
<input checked="" type="checkbox"/>	PHOTOGRAPHS OF EXISTING BUILDING (repairs, rehabs, or expansions)
<input checked="" type="checkbox"/>	PHOTOGRAPHS OF ADJACENT BUILDINGS (new buildings and additions)
<input checked="" type="checkbox"/>	ILLUSTRATIONS OF MANUFACTURED PRODUCTS TO BE USED SUCH AS SHUTTERS, DOORS, WINDOWS, PAINT COLOR CHIPS, AND AWNING FABRIC SAMPLES

Owner: KEYWEST Type: OC Drawer: 1
Date: 4/9/14 22 Registrar no: 22512
PT 2014 1883579
* BUILDING PERMITS ONLY
Trans number: 1.00 Date: 4/9/14 Fee: \$100.00
CHK CHECK 7734 Fee: \$100.00
Trans date: 4/01/14 Time: 19:19:09
Staff Approval: _____
Fee Due: \$ _____

HISTORIC ARCHITECTURAL REVIEW APPLICATION

HISTORIC ARCHITECTURAL REVIEW COMMISSION USE ONLY

Approved

Denied

Deferred

Reason for Deferral or Denial:

HARC Comments:

*Main building is listed as contributing frame vernacular
built ca. 1935.*

*Guidelines for additions/alterations
Ordinance for demolition of non-historic-
non-contributing.*

Limit of Work Approved, Conditions of Approval and/or Suggested
Changes:

Date: _____

Signature: _____

Historic Architectural
Review Commission

Prepared by and return to:

The Smith Law Firm
333 Fleming Street
Key West, FL 33040
305-296-0029

[Space Above This Line For Recording Data]

Warranty Deed

This Indenture made this 28th day of February 2014, between Brian F. Wruble, a married man, whose post office address is 1107 Key Plaza PMB 447, Key West, Florida 33040 grantor, and Lawrence E. Eynon, M.D. and Donald S. Beck, both single men, as joint tenants with rights of survivorship, whose post office address is 550 Liberty Hill, Cincinnati, Ohio 45210, grantees:

(Whenever used herein the terms grantor and grantee include all the parties to this instrument and the heirs, legal representatives, and assigns of individuals, and the successors and assigns of corporations, trusts and trustees)

Witnesseth, that said grantor, for and in consideration of the sum TEN DOLLARS (\$10.00) and other good and valuable considerations to said grantor in hand paid by said grantees, the receipt whereof is hereby acknowledged, have granted, bargained, and sold to the said grantees, and grantees heirs and assigns forever, the following described land, situate, lying and being in **Monroe County**, Florida, to-wit:

On the Island of Key West, Monroe County, Florida and known on William A. Whitehead's Map of the said Island delineated in February, A.D., 1829 as a part of Lots 3 and 4 in Square 21, and being more particularly described as follows:
Commence at the intersection of Northwesterly Right-of-Way Line of Eaton Street and the Northeasterly Right-of-Way Line of William Street;
thence in a Northeasterly direction along the said Northwesterly Right-of-Way Line of Eaton Street for 204.00 feet;
thence at a right angle and in a Northwesterly direction for 99.00 feet;
thence at a right angle and in a Northeasterly direction for 1.30 feet;
thence at a right angle and in a Northwesterly direction for 54.85 feet to the Point of Beginning;
thence continue in a Northwesterly direction for 41.77 feet;
thence at a right angle and in a Southwesterly direction for 32.0 feet;
thence at an angle deflected 89°59'16" to the left and in a Southeasterly direction 41.8 feet;
thence at an angle deflected 90°03'07" to the left and in a Northeasterly direction 32.0 feet back to the Point of Beginning.
Containing 1337 sq. ft., more or less

Sanborn Maps

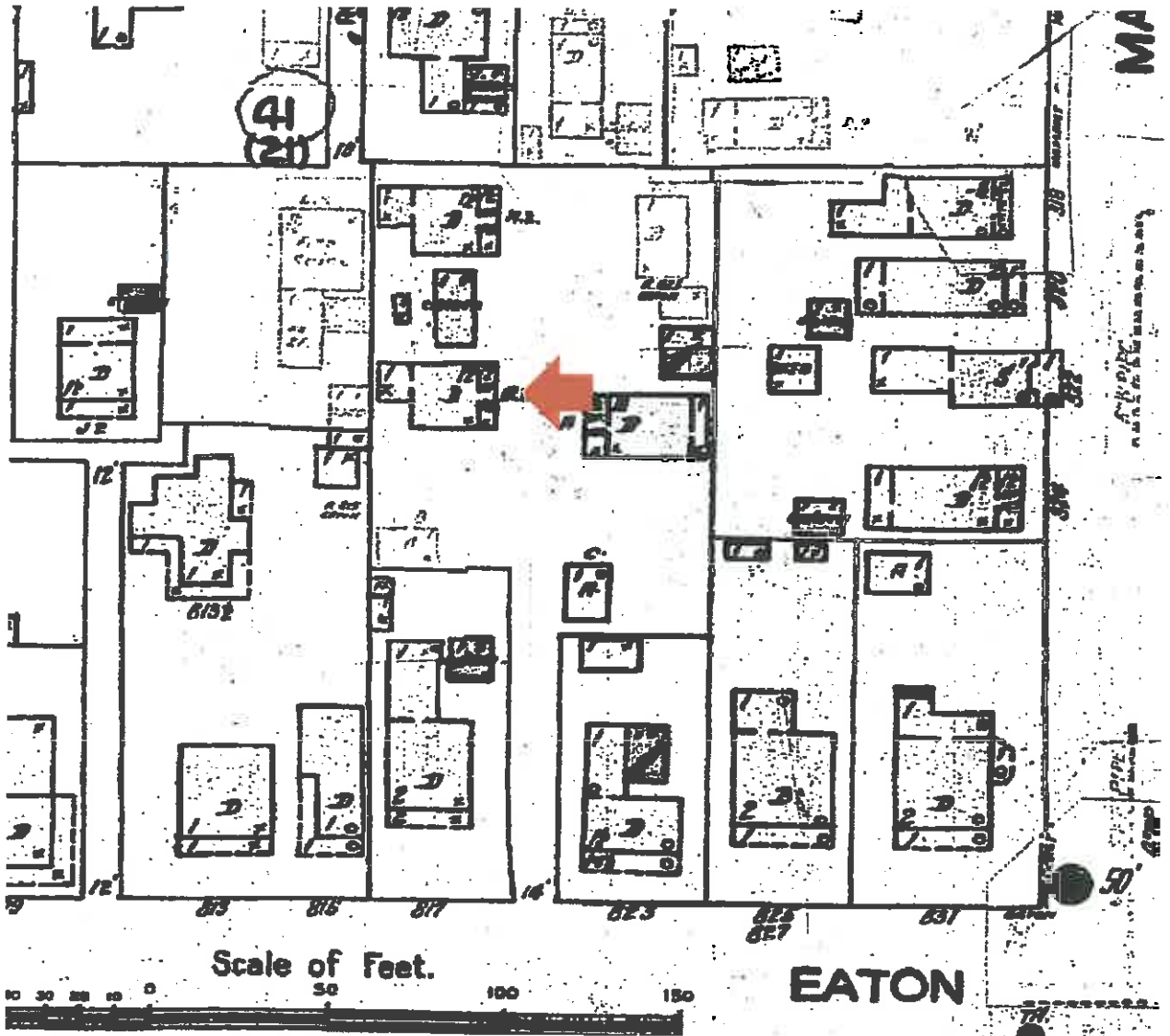

#2 Gecko Lane Sanborn map 1948

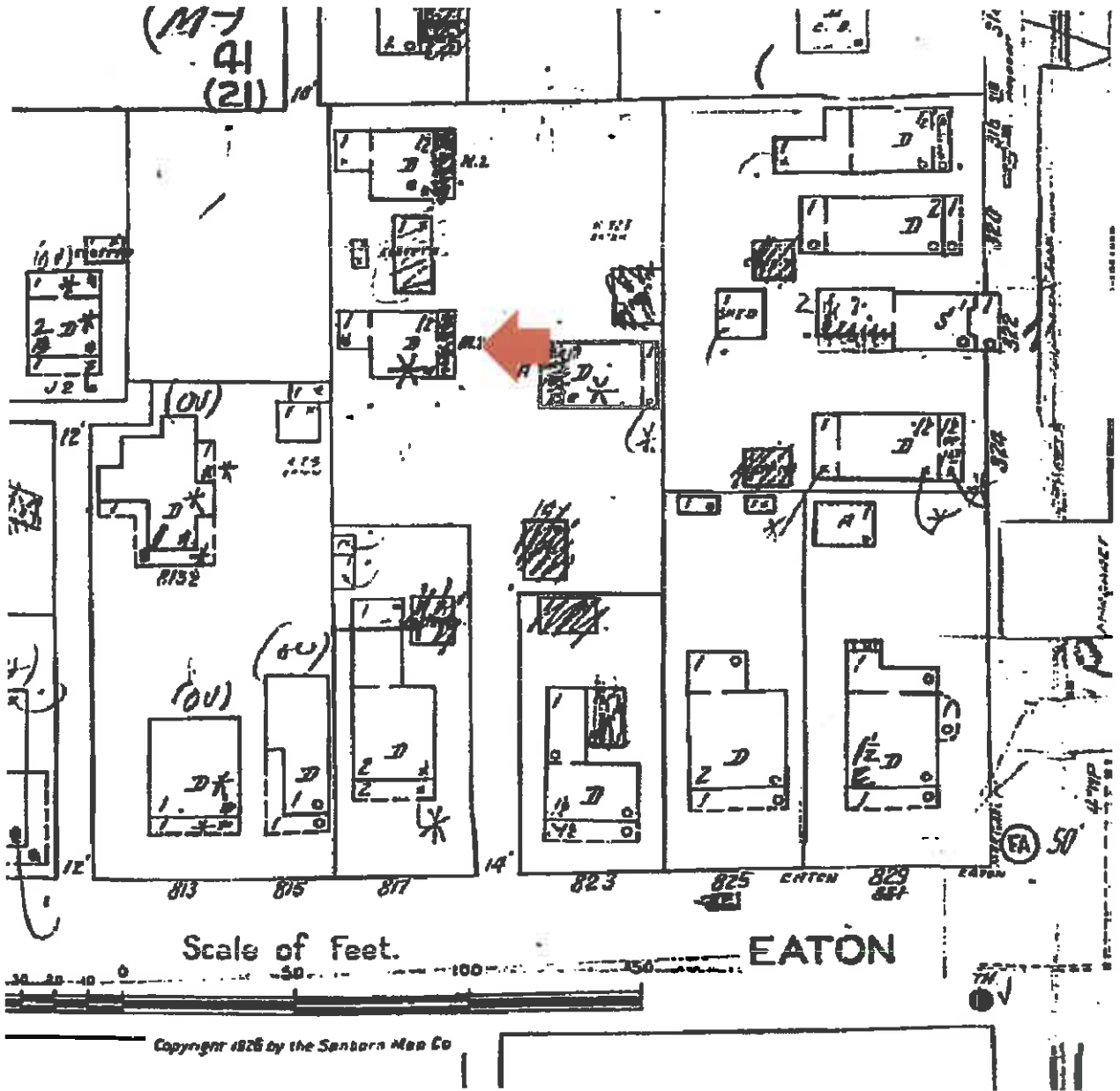

#2 Gecko Lane Sanborn map 1962

Project Photos



#2 Gecko Lane ca. 1965. Monroe County Library.



GECKO LANE from EATON ST.



817 EATON ST at head of GECKO LANE (on right)



Side of 217 EATON ST along GECKO LANE



Fence enclosing pool of 2 GECKO LANE



2 GECKO LANE Fence enclosing pool, original front facade

Side Porch roof

309 Carabellia Avenue

2 GECKO LANE looking SW toward lot location of new addition 6



AGERKO LANE



View of rear of original Main House from lot.
One story addition to be removed.



Original porch on front of Main House @
Gecko Lane.



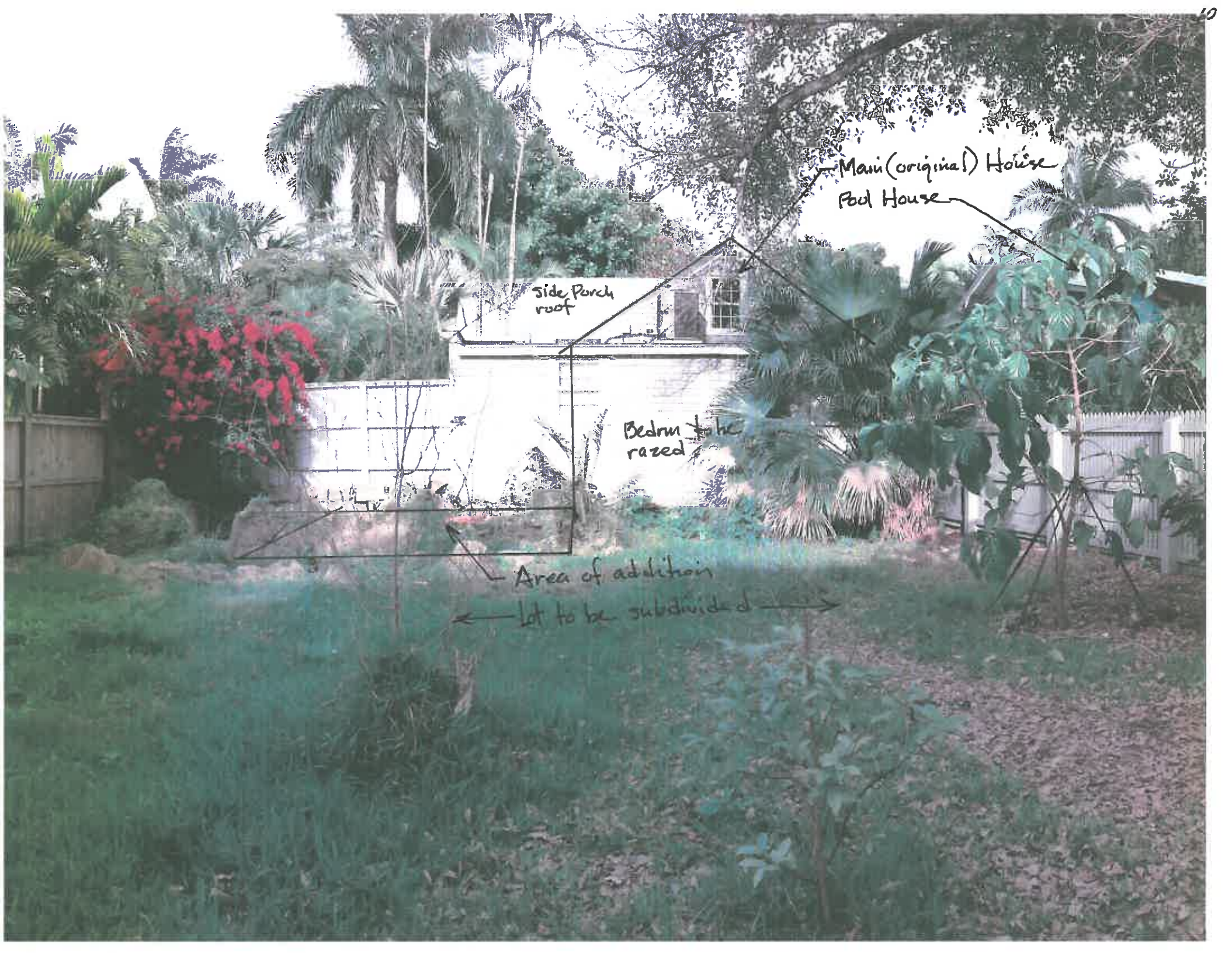

Main (original) House
Pool House

Side Porch
roof

Bedrm to be
razed

Area of addition

Lot to be subdivided



Side Porch roof

Fence to be
partially
removed

Bedroom/Bath
to be razed

Pool House

Main House (near)



309 Caraballo Lane (Wrubbe Residence) NB side with lot in foreground 12



Looking NW at Bedroom addition to be removed.
Original house is to the right.



This is a porch addition to the Pool House, 1989.
The new porch on the rear of Main House will be similar.

Survey

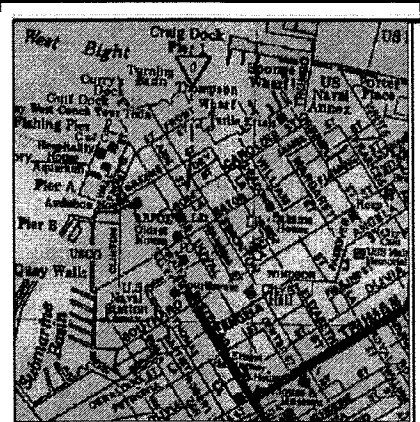

LOCATION MAP - NTS

LEGAL DESCRIPTION - O.R. BOOK 1090, PAGE 2445 (PROVIDED)

On the Island of Key West, and known as part of Lot 1 of Square 21, according to the Map or Plan of the Island of Key West, as delineated in February, 1829 by William A. Whitehead, but better described as follows:
 COMMENCING at the corner of Margaret and Eaton Streets;
 thence running along Eaton Street in a Southwesterly direction 152.4 feet;
 thence at right angles and in a Northwesterly direction 99.0 feet to a Point of Beginning;
 thence at right angles and in a Southwesterly direction 44.3 feet;
 thence at right angles and in a Northwesterly direction 91.0 feet;
 thence at right angles and in a Northeasterly direction 44.3 feet;
 thence at right angles and in a Southeasterly direction 91.0 feet to the Point of Beginning.

TOGETHER WITH an undivided (1/4) one-fourth interest in the following land:
 On the Island of Key West, and known as part of Lot One (1) of Square Twenty-one (21), according to the Map or Plan of the Island of Key West, as delineated in February 1829 by William A. Whitehead, but better described as follows:
 COMMENCING at the corner of Margaret and Eaton;
 thence running along Eaton Street in a Southwesterly direction 142.4 feet to a Point of Beginning;
 thence at right angles and in a Northwesterly direction 190.0 feet;
 thence at right angles and in a Southwesterly direction 10.0 feet;
 thence at right angles and in a Southeasterly direction 190.0 feet;
 thence at right angles and in a Northeasterly direction 10.0 feet to the Point of Beginning. SUBJECT TO the express condition that this strip of land be used solely as a private alley-way to serve the owners of the strip of land, their heirs and assigns, for ingress and egress to their property and is not to be partitioned or sold, closed or used for any other purpose except by the written unanimous consent of all the owner of said strip of land.

AND
 LEGAL DESCRIPTION - UNRECORDED SKETCH BY THE UNDERSIGNED DATED 04/11/13

On the Island of Key West, Monroe County, Florida and known as William A. Whitehead's Map of the said Island delineated in February, A.D., 1829 as a part of Lots 3 and 4 in Square 21, and being more particularly described as follows: Commence at the intersection of Northwesterly Right-of-Way Line of Eaton Street and the Northeasterly Right-of-Way Line of William Street;
 thence in a Northwesterly direction along the said Northwesterly Right-of-Way Line of Eaton Street for 204.00 feet;
 thence at a right angle and in a Northwesterly direction for 99.00 feet;
 thence at a right angle and in a Northwesterly direction for 1.30 feet;
 thence at a right angle and in a Northwesterly direction for 96.62 feet;
 thence at a right angle and in a Southwesterly direction for 22 feet to the Point of Beginning of the following described easement;
 thence continue in a Southwesterly direction for 10 feet;
 thence at an angle deflected 89°59'16" to the left and in a Southeasterly direction 41.8 feet;
 thence at an angle deflected 90°03'07" to the left and in a Northeasterly direction 32.0 feet back to the Point of Beginning. Containing 1337 sq. ft., more or less

SUBJECT TO THE FOLLOWING DESCRIBED EASEMENT-
 On the Island of Key West, Monroe County, Florida and known as William A. Whitehead's Map of the said Island delineated in February, A.D., 1829 as a part of Lot 4 in Square 21, and being more particularly described as follows: Commence at the intersection of Northwesterly Right-of-Way Line of Eaton Street and the Northeasterly Right-of-Way Line of William Street;
 thence in a Northwesterly direction along the said Northwesterly Right-of-Way Line of Eaton Street for 204.00 feet;
 thence at a right angle and in a Northwesterly direction for 99.00 feet;
 thence at a right angle and in a Northwesterly direction for 1.30 feet;
 thence at a right angle and in a Northwesterly direction for 96.62 feet;
 thence at a right angle and in a Southwesterly direction for 22 feet to the Point of Beginning of the following described easement;
 thence continue in a Southwesterly direction for 10 feet;
 thence at an angle deflected 89°59'16" to the left and in a Southeasterly direction 41.8 feet;
 thence at an angle deflected 90°03'07" to the left and in a Northeasterly direction 32.0 feet;
 thence at an angle deflected 89°56'53" to the left and in a Northwesterly direction 41.79 feet back to the Point of Beginning.

CL WILLIAM STREET (50' ROW)

POC UNRECORDED SKETCH - INTERSECTION OF EATON & WILLIAM STREETS
 BLOCK CORNER FND NAIL & DISC, FHH 2749
 FND NAIL & DISC, FHH 2749
 3.0' X 3.0' OFFSET

309 CARABALLO LANE RE# 00003350-000000

BEARING BASE: 90° LOT
 ALL ANGLES DEPICTED ARE 90 DEGREES UNLESS OTHERWISE INDICATED
 ADDRESS: 2 GECKO LANE KEY WEST FL 33040

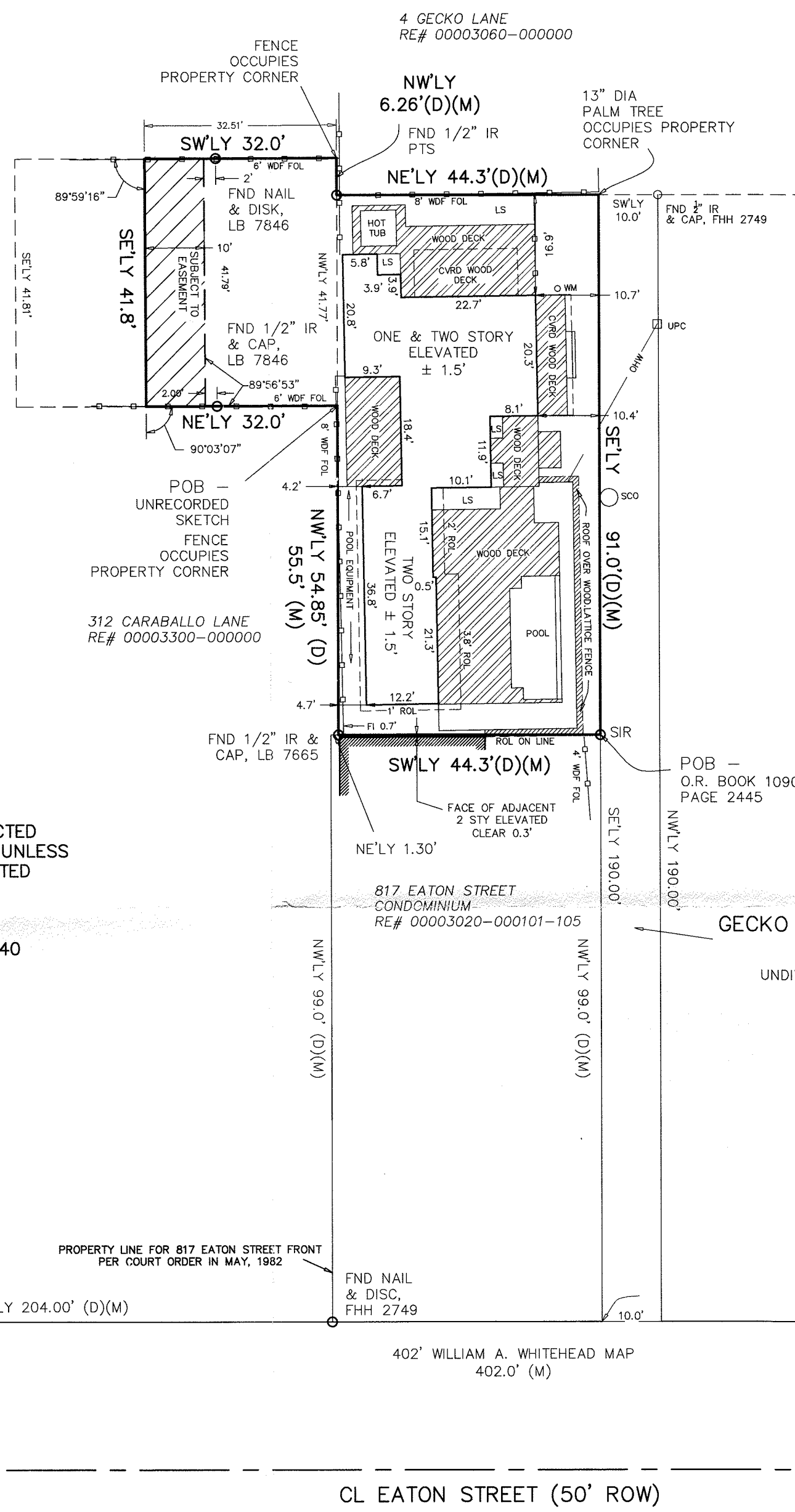

MAP OF BOUNDARY SURVEY
 PART LOTS 1 AND 4, SQUARE 21
 WILLIAM A. WHITEHEAD'S MAP
 ON THE ISLAND OF KEY WEST

NORTH ASSUMED FROM LEGAL DESCRIPTION
 SCALE: 1" = 20'

CL MARGARET STREET (50' ROW)

POC O.R. BOOK 1090, PAGE 2445 THE CORNER OF MARGARET AND EATON STREETS
 BLOCK CORNER FND NAIL & DISC, FHH 2749

LEGAL DESCRIPTION - SEE ABOVE

CERTIFIED TO - LAWRENCE E. EYNON, M.D. DONALD S. BECK

NOTES: THIS SURVEY WAS PERFORMED FOR THE SOLE AND EXCLUSIVE BENEFIT OF THE PARTIES LISTED HEREIN AND SHALL NOT BE RELIED UPON BY ANY OTHER ENTITY OR INDIVIDUAL WHOSOEVER. LIKEWISE, ANY REUSE OF THIS SURVEY FOR ANY PURPOSE OTHER THAN WHICH WAS ORIGINALLY INTENDED, WITHOUT THE WRITTEN PERMISSION OF THE UNDERSIGNED SURVEYOR & MAPPER, WILL BE DONE SO AT THE RISK OF THE REUSING PARTY AND WITHOUT ANY LIABILITY TO THE UNDERSIGNED SURVEYOR & MAPPER.

NOTE: MEASURED DIMENSIONS EQUAL PLATTED OR DESCRIBED DIMENSIONS UNLESS INDICATED OTHERWISE. FOUNDATIONS BENEATH THE SURFACE ARE NOT SHOWN. THE FOLLOWING IS A LIST OF ABBREVIATIONS THAT MAY BE FOUND ON THIS SHEET.

SCALE: 1"=20'
 FIELD WORK DATE: 09/23/13
 REVISION DATE: -/-/
 SHEET 1 OF 1
 DRAWN BY: KB
 CHECKED BY: RW
 INVOICE #: 13081201

REECE & WHITE LAND SURVEYING, INC.
 PROFESSIONAL SURVEYOR AND MAPPER, LB 7846
 127 INDUSTRIAL ROAD, BIG PINE KEY, FL 33043
 OFFICE (305) 872 - 1348
 FAX (305) 872 - 5622

LEGAL DESCRIPTIONS HAVE BEEN FURNISHED BY THE CLIENT OR HIS/HER REPRESENTATIVE. PUBLIC RECORDS HAVE NOT BEEN RESEARCHED BY THE SURVEYOR TO DETERMINE THE ACCURACY OF THESE DESCRIPTIONS NOR HAVE ADJOINING PROPERTIES BEEN RESEARCHED TO DETERMINE OVERLAPS OR HIATUS.

THIS SURVEY DOES NOT PURPORT TO SHOW OWNERSHIP OF WALLS OR FENCES ALONG PROPERTY LINES.

ADDITIONS OR DELETIONS TO THIS SURVEY MAP BY OTHER THAN THE SIGNING PARTY OR PARTIES IS PROHIBITED WITHOUT WRITTEN CONSENT OF THE SIGNING PARTY OR PARTIES.

- | | | | | | | | | | | | | | | | | | | | | | | | | | | | | | | | | | | | | | | | | | | | | | | | | | | | | | | | | | | | | | | | | | | | | | | | |
|---------------------------|-----------------|---------------------------|---------------------|------------------------|-------------------|----------------|-----------------|------------------|--------------------------------|-------------------|-------------|--------------------------|--------------------|---------------------|------------------|------------------|-------------------|---------------|---------------|----------------|---------------|----------------|----------------------|------------------|--------------|--------------|-----------------------------|--------------------|-----------------------|--------------------------|--------------------|----------------------|----------|---------------------|-------------------------------|-------------------------------|----------------------------|------------------------|--------------------|--------------------------|-----------------------------|------------------------------|------------------------------------|-----------------------|------------|--------------------------|--------------------------|--------------------|--------------------------|--------------------------------|---------------------------------|------------------------|-------------------------------|------------------|--------------------|-----------------------|-------------------------|-------------------|--------------------|-------------------|---------------|--------------------------|-----------------------------|-------------------------|----------------|----------------|------------------|-------------------|------------------|--------------------------------------|------------------|
| BFP = BACK-FLOW PREVENTER | CI = CURB INLET | DEASE = DRAINAGE EASEMENT | DELTA = DELTA ANGLE | DMH = DRAINAGE MANHOLE | EB = ELECTRIC BOX | EL = ELEVATION | ELEV = ELEVATED | ENCL = ENCLOSURE | FEE = FINISHED FLOOR ELEVATION | FI = FENCE INSIDE | FND = FOUND | FND& = FOUND NAIL & DISK | FO = FENCE OUTSIDE | FOL = FENCE ON LINE | GB = GRADE BREAK | GI = GRATE INLET | GL = GROUND LEVEL | GW = GUY WIRE | HB = HOSE BIB | IP = IRON PIPE | IR = IRON ROD | L = ARC LENGTH | LE = LOWER ENCLOSURE | LS = LANDSCAPING | M = MEASURED | MB = MAILBOX | MHWL = MEAN HIGH WATER LINE | MTLF = METAL FENCE | NAVD = NORTH AMERICAN | NGVD = NATIONAL GEODETIC | NTS = NOT TO SCALE | OHW = OVERHEAD WIRES | P = PLAT | PC = POINT OF CURVE | POC = POINT OF COMPOUND CURVE | PCP = PERMANENT CONTROL POINT | PI = POINT OF INTERSECTION | PK = PARKER KALON NAIL | PM = PARKING METER | POB = POINT OF BEGINNING | POC = POINT OF COMMENCEMENT | POC = POINT OF REVERSE CURVE | PRM = PERMANENT REFERENCE MONUMENT | PT = POINT OF TANGENT | R = RADIUS | ROL = ROOF OVERHANG LINE | ROWL = RIGHT OF WAY LINE | R/W = RIGHT OF WAY | SOD = SANITARY CLEAN-OUT | SN&D = SET NAIL & DISK LB 7846 | SIR = SET IRON ROD 1/2" LB 7846 | SMH = SANITARY MANHOLE | SPV = SPRINKLER CONTROL VALVE | SV = SEWER VALVE | TB = TELEPHONE BOX | TBM = TIDAL BENCHMARK | TMH = TELEPHONE MANHOLE | TOB = TOP OF BANK | TOS = TOP OF SLOPE | TS = TRAFFIC SIGN | TYP = TYPICAL | UEASE = UTILITY EASEMENT | UPC = CONCRETE UTILITY POLE | UPW = WOOD UTILITY POLE | VB = VIDEO BOX | WB = WOOD DECK | WDF = WOOD FENCE | WL = WOOD LANDING | WM = WATER METER | WRACK LINE = LINE OF DEBRIS ON SHORE | WV = WATER VALVE |
|---------------------------|-----------------|---------------------------|---------------------|------------------------|-------------------|----------------|-----------------|------------------|--------------------------------|-------------------|-------------|--------------------------|--------------------|---------------------|------------------|------------------|-------------------|---------------|---------------|----------------|---------------|----------------|----------------------|------------------|--------------|--------------|-----------------------------|--------------------|-----------------------|--------------------------|--------------------|----------------------|----------|---------------------|-------------------------------|-------------------------------|----------------------------|------------------------|--------------------|--------------------------|-----------------------------|------------------------------|------------------------------------|-----------------------|------------|--------------------------|--------------------------|--------------------|--------------------------|--------------------------------|---------------------------------|------------------------|-------------------------------|------------------|--------------------|-----------------------|-------------------------|-------------------|--------------------|-------------------|---------------|--------------------------|-----------------------------|-------------------------|----------------|----------------|------------------|-------------------|------------------|--------------------------------------|------------------|

Proposed design

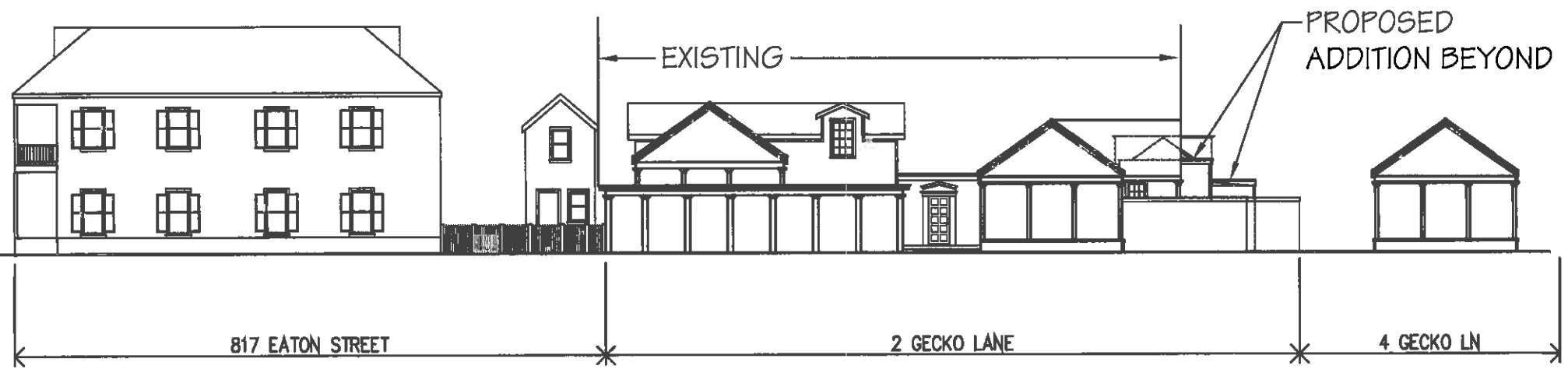

GECKO LANE SOUTHWEST STREET ELEVATION
SCALE: NTS

Addition to Residence owned by: Don Beck & Larry Eynon

2 Gecko Lane
Key West, Florida 33040

PROJECT INFORMATION

PROJECT DESCRIPTION: 1 STORY ADDITION TO EXISTING SINGLE FAMILY RESIDENCE
BUILDING CODES: 2010 FLORIDA BUILDING CODE: RESIDENTIAL

SHEET INDEX

A-1	COVER SHEET AND SITE PLAN	HARC SUBMITTAL 03.21.2014
A-2	FOUNDATION/FRAMING PLAN, GROUND FLOOR, SECOND FLOOR PLANS	HARC SUBMITTAL 03.21.2014
A-3	ELEVATIONS AND SECTIONS	HARC SUBMITTAL 03.21.2014
A-4	SECTIONS AND DETAILS	HARC SUBMITTAL 03.21.2014

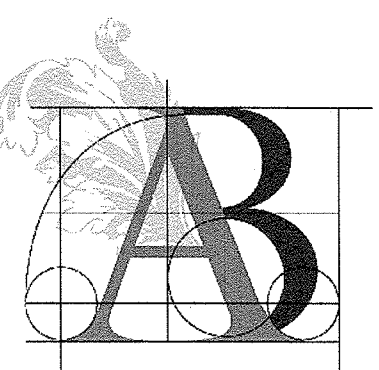

BECK
ARCHITECTURE

550 Liberty Hill
Cincinnati, Ohio
45202-6891

513-651-5550

BeckArchitecture@fuse.net

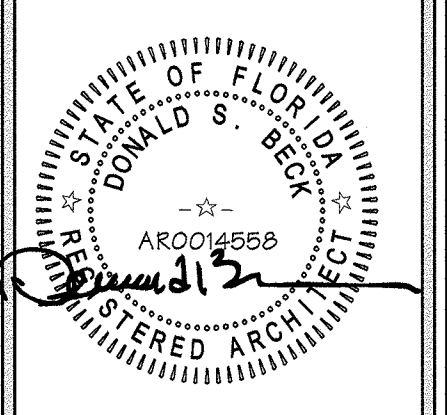

ISSUE	
FOR REVIEW	04.09.2013
HARC SUBMITTAL	03.21.2014
HARC SUBMITTAL	03.21.2014

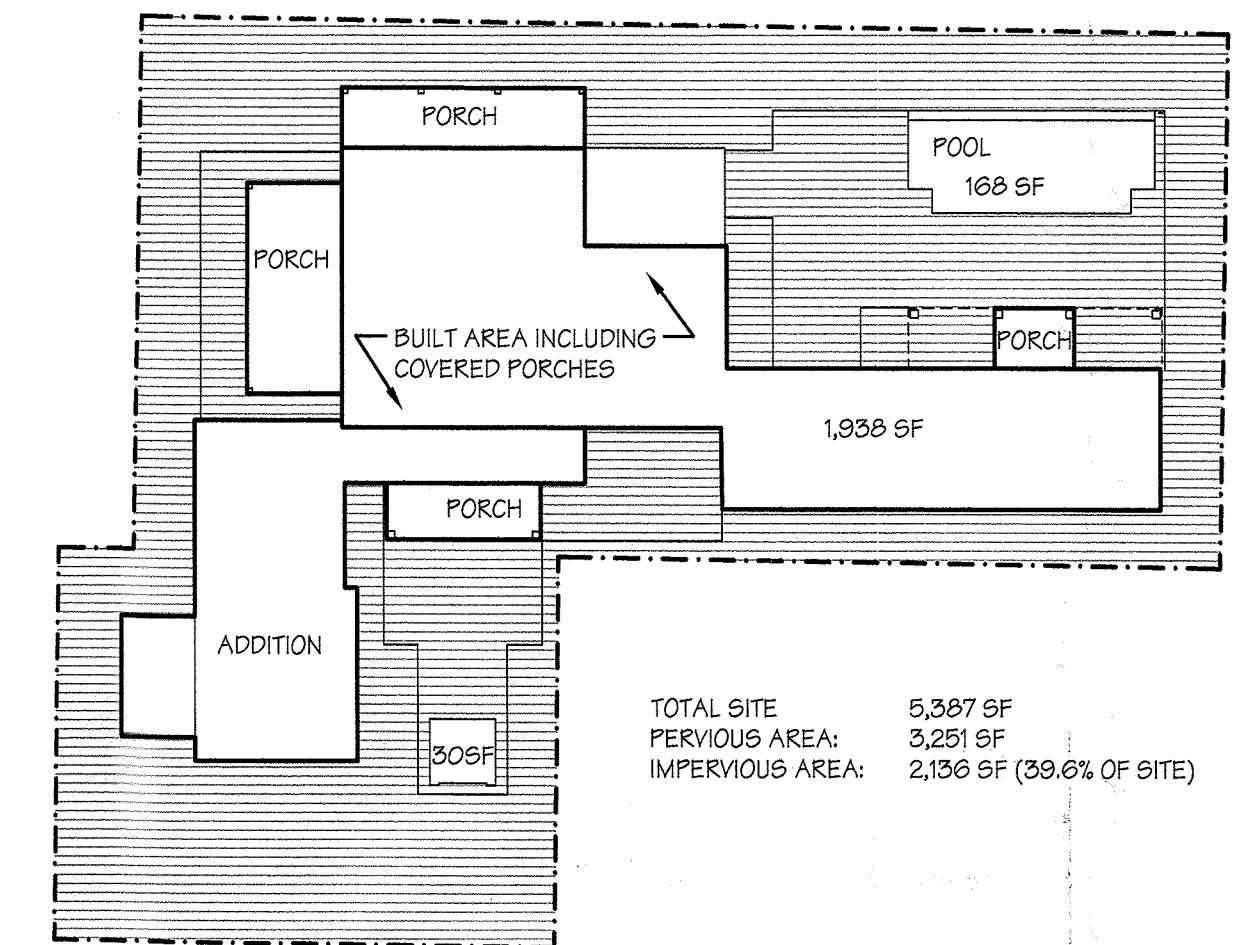
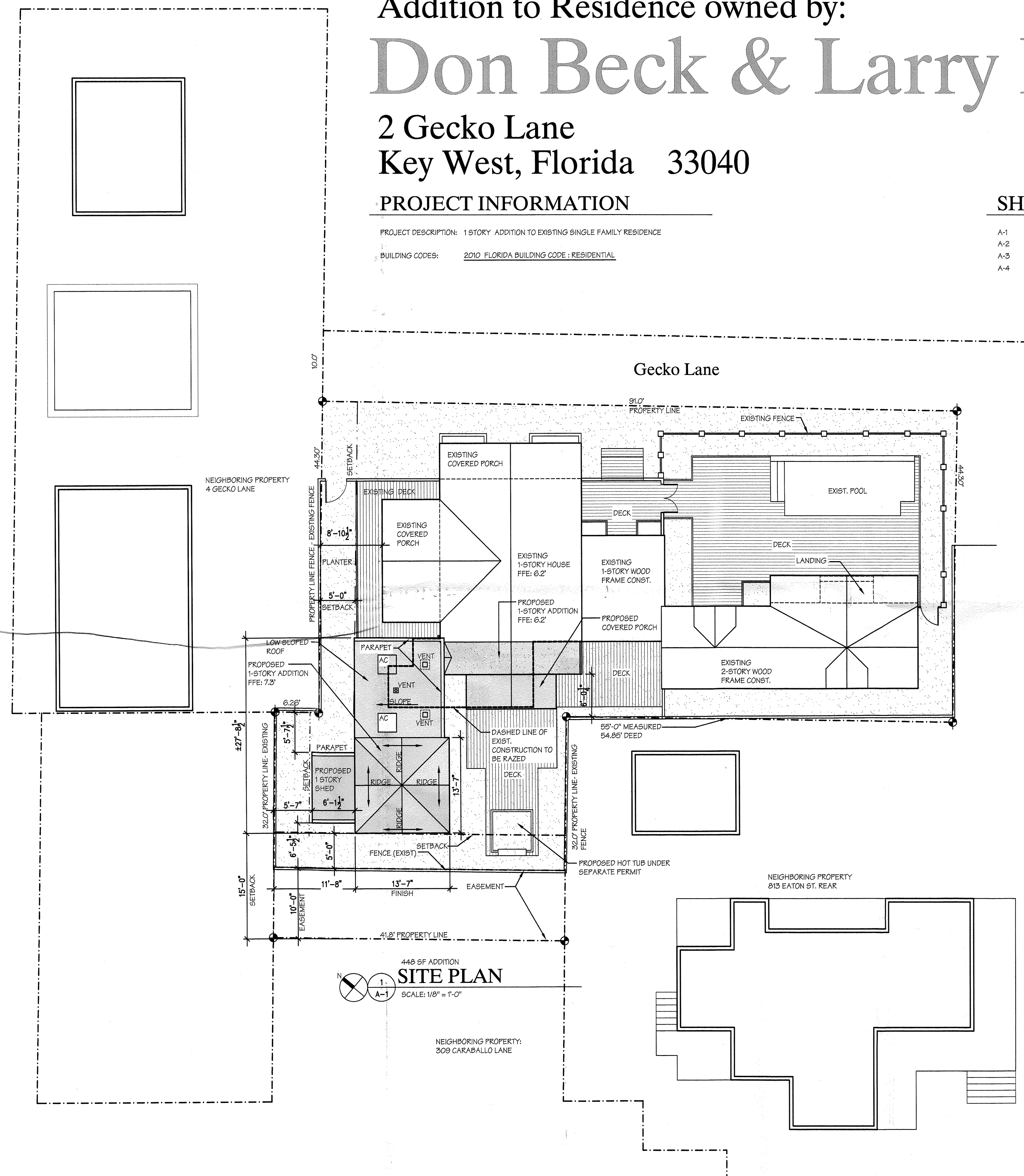

PERVIOUS/IMPERVIOUS AREAS
SCALE: 1/16" = 1'-0"

DOOR SCHEDULE:

NO.	PRODUCT / TYPE	LOCATION	SIZE W X H X T	ELEV	HARDWARE TYPE	FINISH	REMARKS	REUSE FROM:
1	WD. TRUE DIVIDED LITE DOOR	LIVING ROOM	(2) 3'-0" x 6'-8" x 1 3/4"	E	PASSAGE	PAINT	DEADBOLT/DUMMY PULL W/ EDGE BOLTS	
1A	WD. TRUE DIVIDED LITE	LIVING ROOM	(2) 3'-0" x 6'-8" x 1 3/4"	E	FIXED	PAINT	NO HARDWARE	
2	LOUVERED PANEL*	UTILITY	2'-4" x 6'-8" x 1 3/8"	B	PASSAGE*	PAINT	RE-USED DOOR AND HARDWARE	BEDROOM CLOSET; REVERSE
3	SOLID FLAT PANEL*	HALL	2'-6" x 6'-8" x 1 3/8"	A	POCKET	PAINT		
4	SOLID FLAT PANEL*	BATH #2	2'-6" x 6'-8" x 1 3/8"	A	PASSAGE*	PAINT	RE-USED DOOR AND HARDWARE	BATH ENTRY; REVERSE
5	SOLID FLAT PANEL*	BEDROOM #2	2'-6" x 6'-8" x 1 3/8"	A	PASSAGE*	PAINT	RE-USED DOOR AND HARDWARE	BEDROOM ENTRY
6	LOUVERED PANEL	BEDROOM #2	(2) 2'-0" x 6'-8" x 1 3/8"	B	DUMMY	PAINT	LH/RH DUMMY PULLS W/ ROLLER CATCHES	
7	WD. TRUE DIVIDED LITE DOOR	BEDROOM #2	(2) 2'-6" x 6'-8" x 1 3/4"	D	PASSAGE	PAINT	DEADBOLT/DUMMY PULL, EDGE BOLTS	
8	LOUVERED PANEL	MECHANICAL	2'-4" x 6'-8" x 1 3/8"	B	PASSAGE	PAINT	HARDWARE ON OUTSIDE ONLY	
9	8 PANEL DOOR T.M.E.	BIKE STORAGE	3'-0" x 6'-8" x 1 3/8"	C	PASSAGE*	PAINT	KEYED DEADBOLT WITH LATCH INSIDE	LIVING ROOM EXIT TO DECK

- * REUSE FROM DEMOLISHED BEDROOM
- 1. HINGES: 4" x 4" PAINTED ON OUTSIDE DOORS, 3 1/4" HIGH x 3" ON INTERIOR DOORS.
- 2. DOORS ARE SIMPSON DOOR COMPANY TO MATCH EXIST.
- 3. DOOR LEVERS: BALDWIN "ESTATE" 5105 OIL RUBBED BRONZE 102 WITH ROSE 5006
- 4. DEADBOLTS: BALDWIN 8041.150 OIL RUBBED BRONZE 102

WINDOW SCHEDULE:

MARK	PRODUCT DESIGNATION	R.O. SIZE	DIVIDE LITES/ SASH			REMARKS	
			T/B	WIDE	HIGH		PATTERN
A	MARYIN WUDH 3032E	3'-0 3/8" x 6'-1 1/2"	YES	3	2	ORTHO	SINGLE PANE GLAZING
B	MARYIN WUDH2424	2'-6 3/8" x 4'-9 1/2"	YES	3	2	ORTHO	SINGLE PANE GLAZING

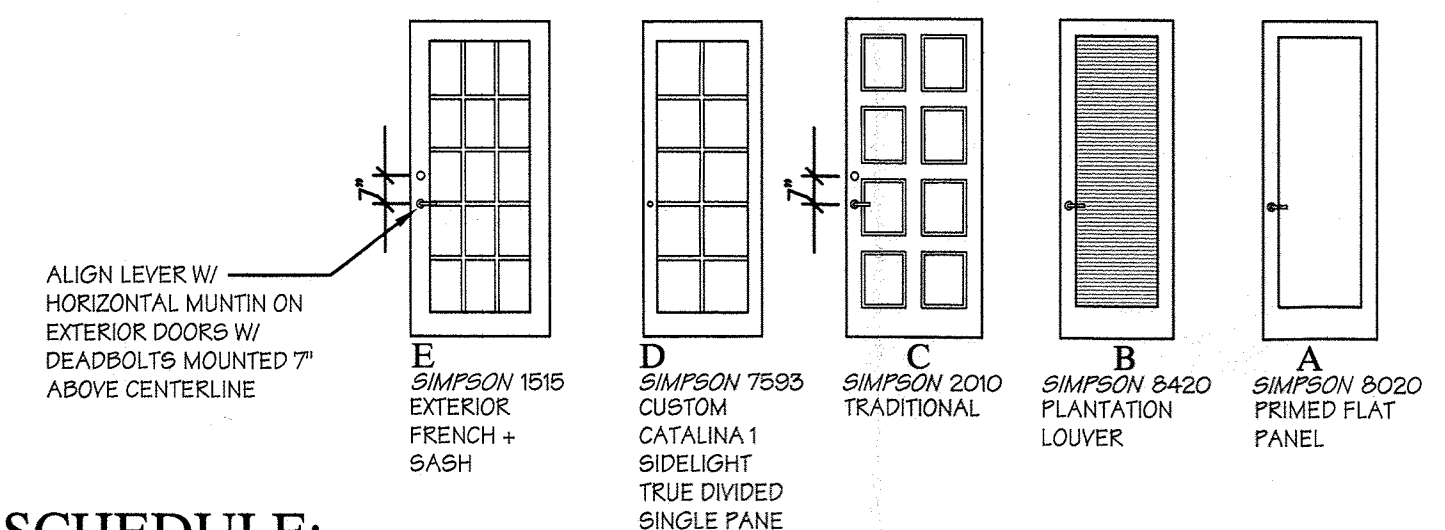

Beck/Eynon Residence
2 Gecko Lane Key West, Florida

PROJECT
DRAWING TITLE
SITE PLAN

SHEET

A-1

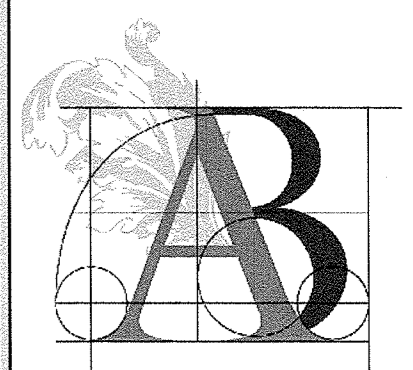

BECK
ARCHITECTURE

550 Liberty Hill
Cincinnati, Ohio
45202-6891

513-651-5550
BeckArchitecture@fuse.net

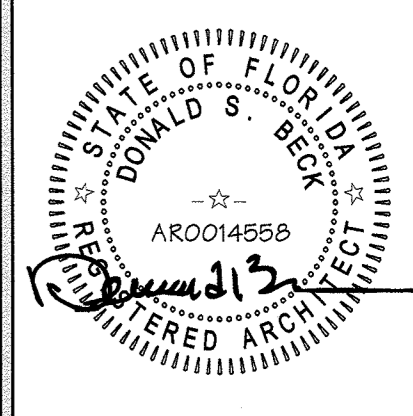

ISSUE
FOR REVIEW 03.15.2013
HARC SUBMITTAL 03.21.2014

Beck/Eynon Residence
2 Gecko Lane Key West, Florida

PROJECT
DRAWING TITLE
FOUNDATION/FRAMING, GROUND FLOOR, 2ND FLOOR PLANS

SHEET
A-2
2013 © Beck Architecture Inc.

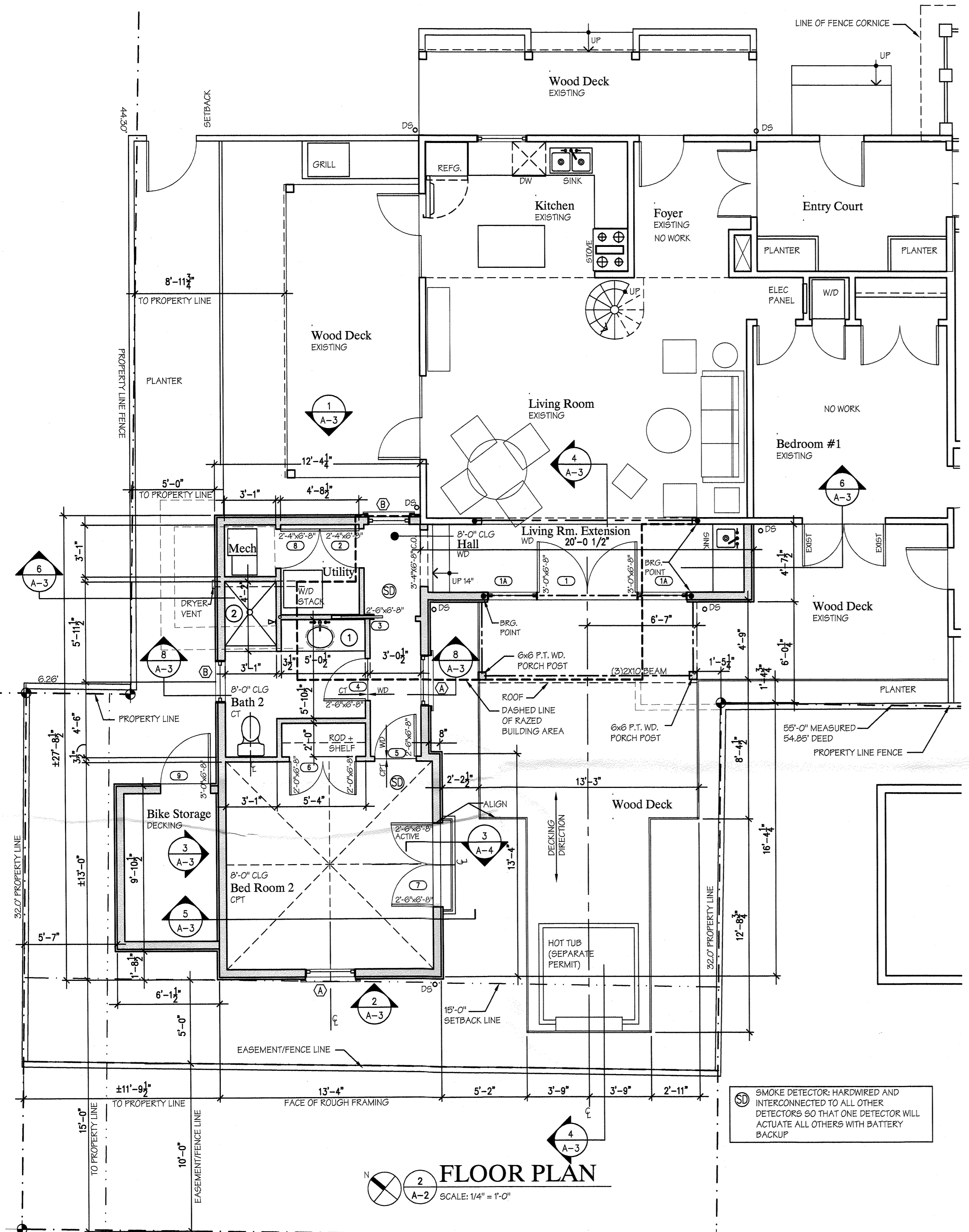

FLOOR PLAN
SCALE: 1/4" = 1'-0"

CONSTRUCTION NOTES

- 1 RE-USED TOP, SINK, AND FAUCET - CUT DOWN FROM 6"-1"
- 2 USE MOISTURE RESISTANT GREEN BOARD IN WET AREAS

ROOM FINISH LEGEND

ROOM NAME	FLOOR	BASE	WALL	CEILING	REMARKS
LIVING ROOM EXTENSION	2 1/4"x3/4" OAK T&E	1x6	T&G WD, PTD	DRYWALL	
HALL	2 1/4"x3/4" OAK T&E	1x6	DRYWALL	DRYWALL	
BATH 2	CERAMIC TILE	TILE	DRYWALL	DRYWALL	2X2 CT SHOWER FLOOR & WALLS
BEDROOM 2	CARPET	1x6	DRYWALL	DRYWALL	
STORAGE	PT 2X4 DECKING	1x6	DRYWALL	DRYWALL	
MECHANICAL	CERAMIC TILE	1x6	DRYWALL	DRYWALL	
UTILITY	CERAMIC TILE	1x6	DRYWALL	DRYWALL	

SMOKE DETECTOR: HARDWIRED AND INTERCONNECTED TO ALL OTHER DETECTORS SO THAT ONE DETECTOR WILL ACTUATE ALL OTHERS WITH BATTERY BACKUP

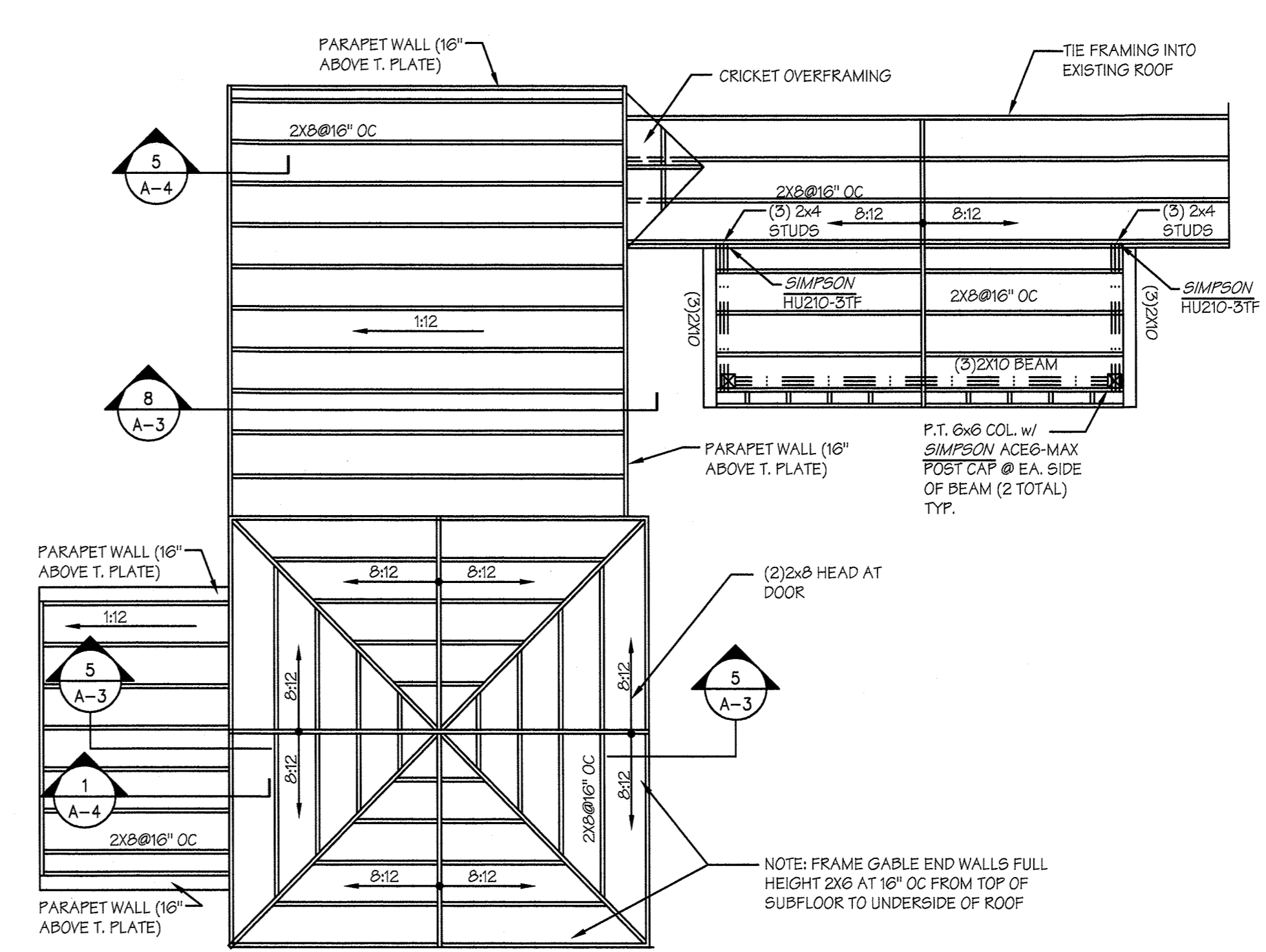

ROOF FRAMING PLAN
SCALE: 1/4" = 1'-0"

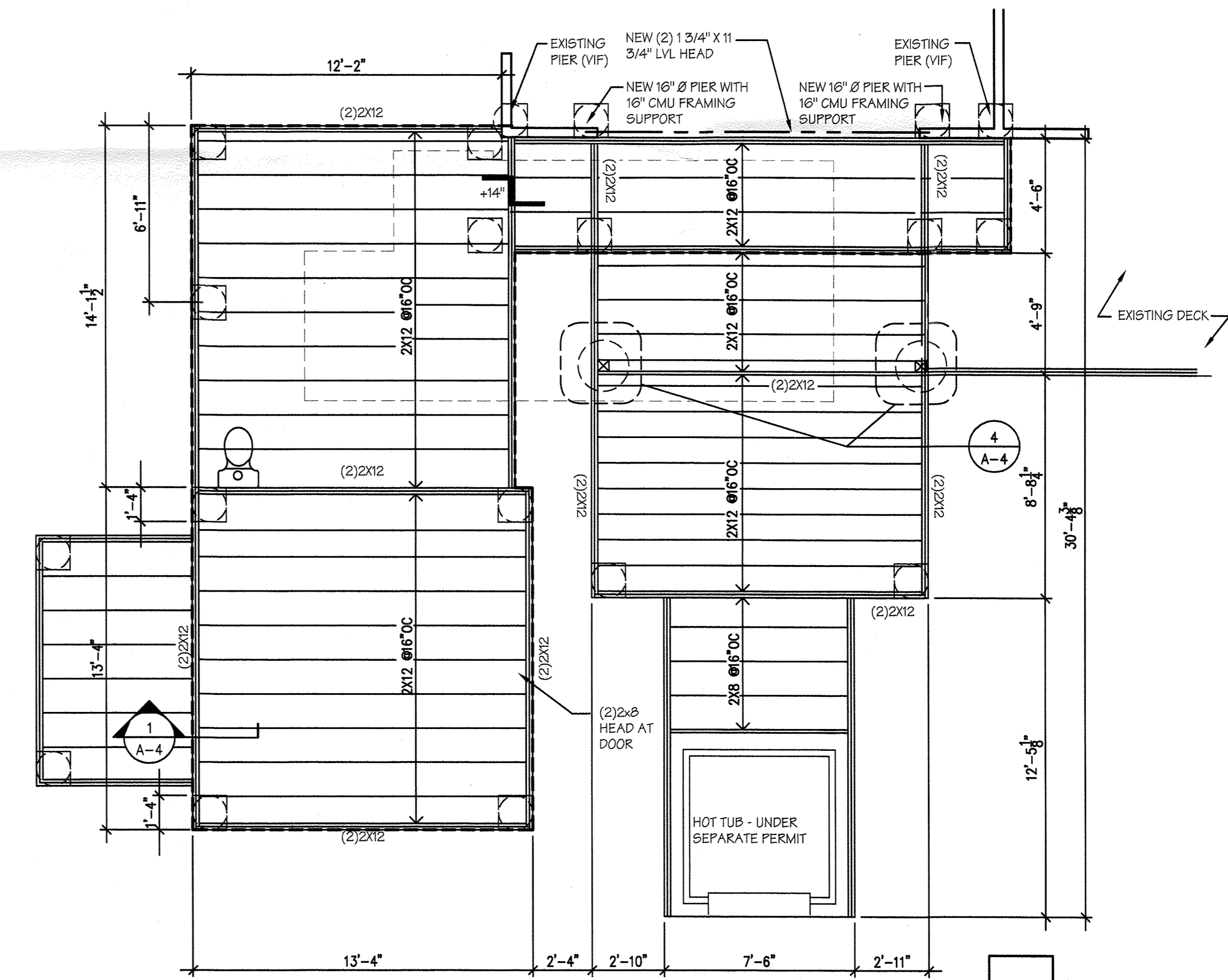

FOUNDATION/FRAMING PLAN
SCALE: 1/4" = 1'-0"

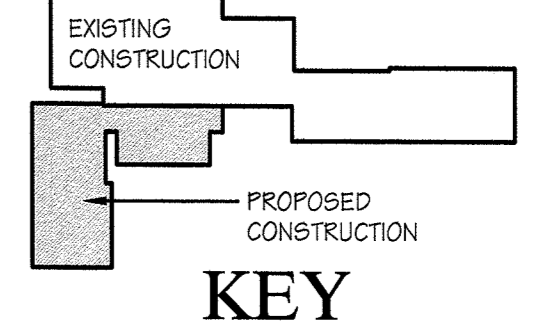

KEY

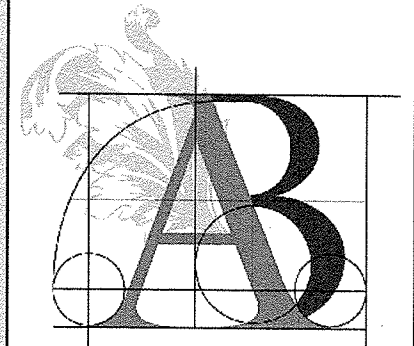

BECK
ARCHITECTURE

550 Liberty Hill
Cincinnati, Ohio
45202-6891

513-651-5550
BeckArchitecture@fuse.net

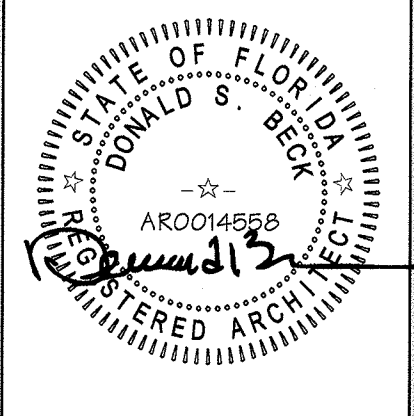

ISSUE
FOR REVIEW 03.15.2013
HARC SUBMITTAL 03.21.2014

Beck/Eynon Residence
2 Gecko Lane Key West, Florida

PROJECT
DRAWING TITLE
ELEVATIONS

SHEET
A-3

2013 © Beck Architecture Inc.

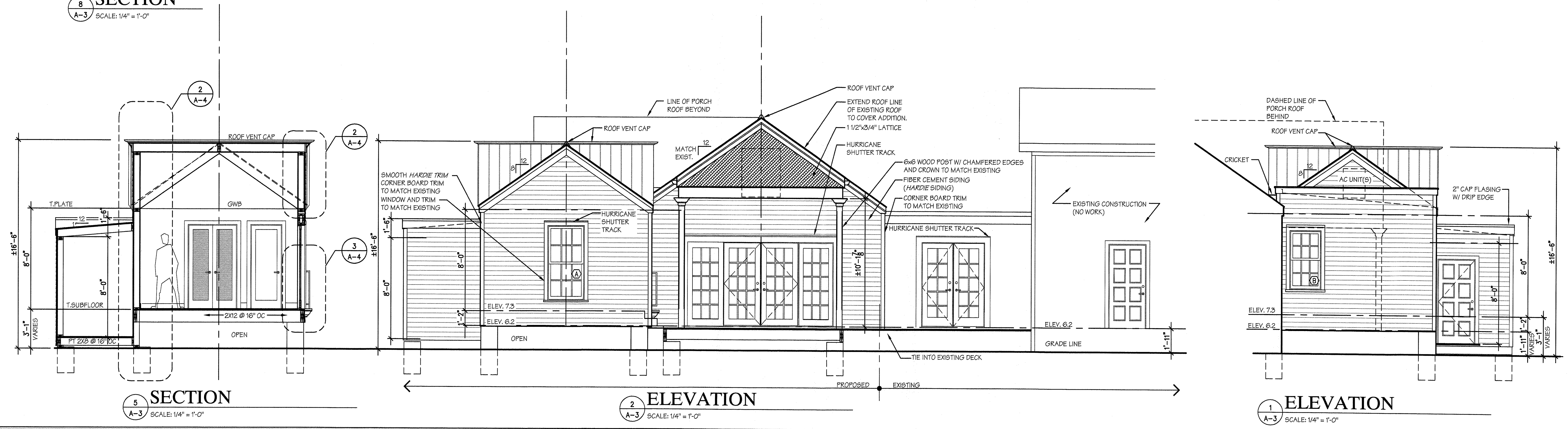
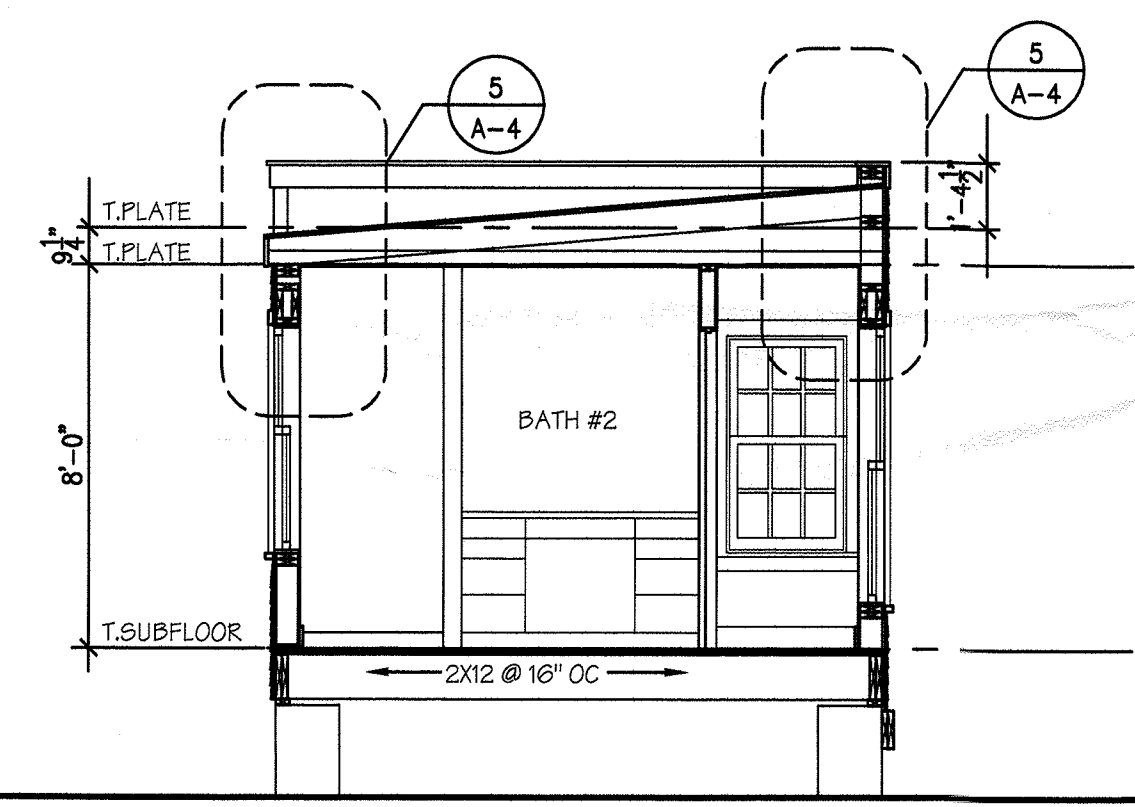
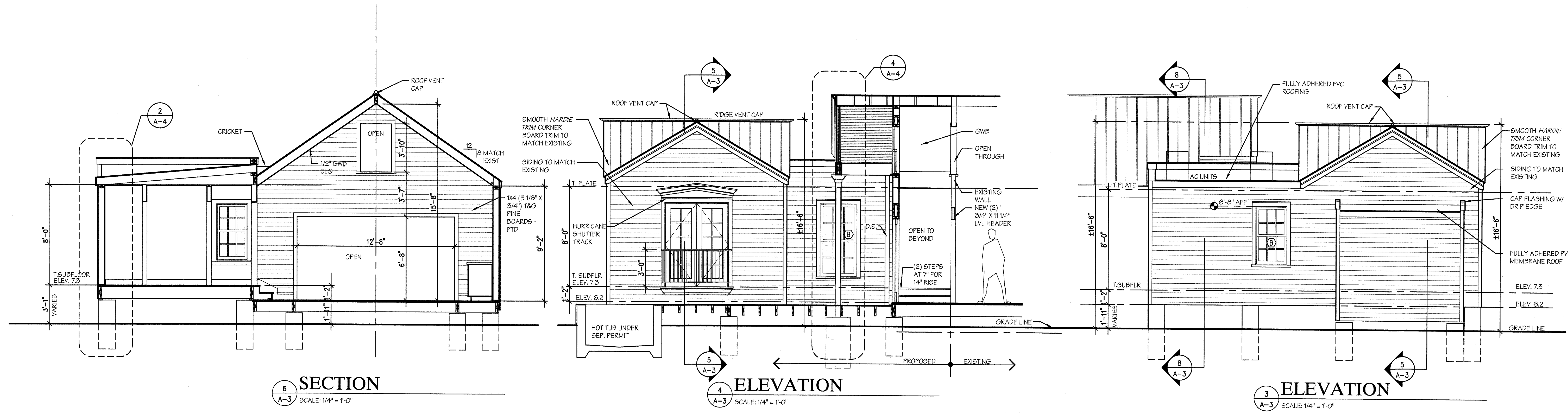

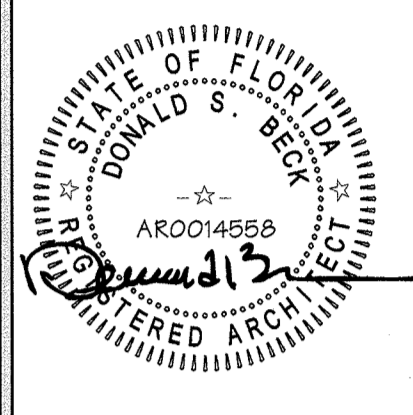

ISSUE
FOR REVIEW 03.15.2013
HARC SUBMITTAL 03.21.2014

Beck/Eynon Residence
2 Gecko Lane Key West, Florida

PROJECT
DRAWING TITLE
DETAILS

SHEET

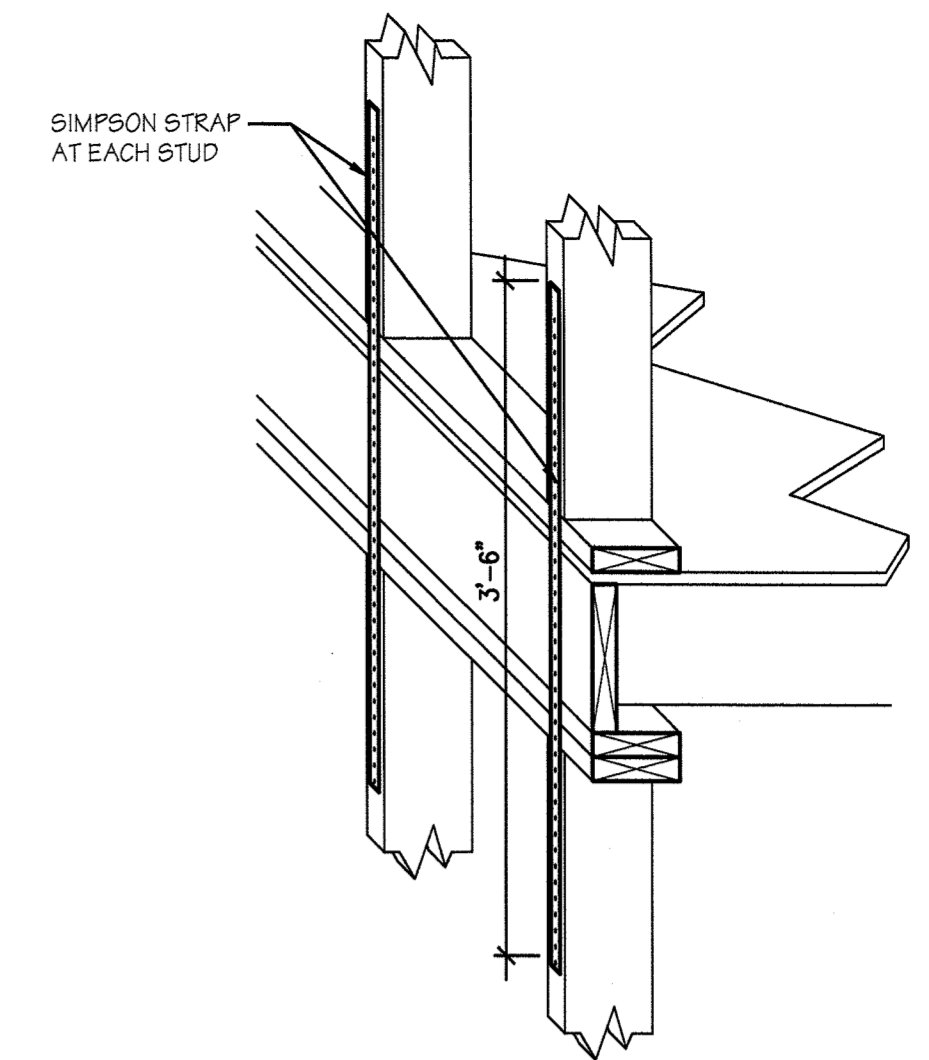

TYP ROOF CONST.

V-CRIMP METAL ROOFING TO MATCH EXISTING ON 30# ROOFING FELT OVER 3/2" APA RATED PLYWD. SHEATHING ON 2x8 ROOF RAFTERS @ 24" o.c.

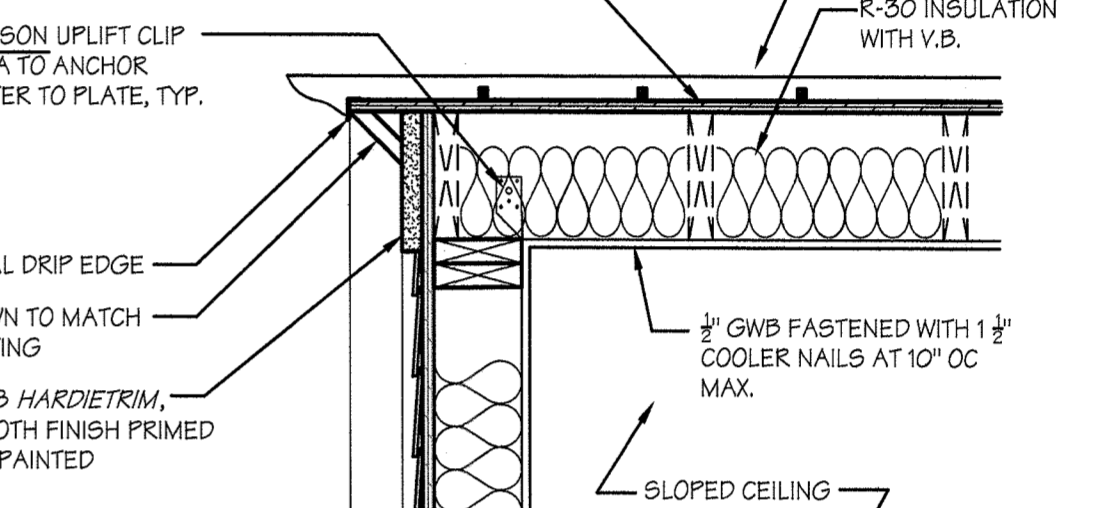

TYP ROOF CONST.

V-CRIMP METAL ROOFING TO MATCH EXISTING ON 30# ROOFING FELT OVER 3/2" APA RATED PLYWD. SHEATHING ON 2x8 ROOF RAFTERS @ 24" o.c.

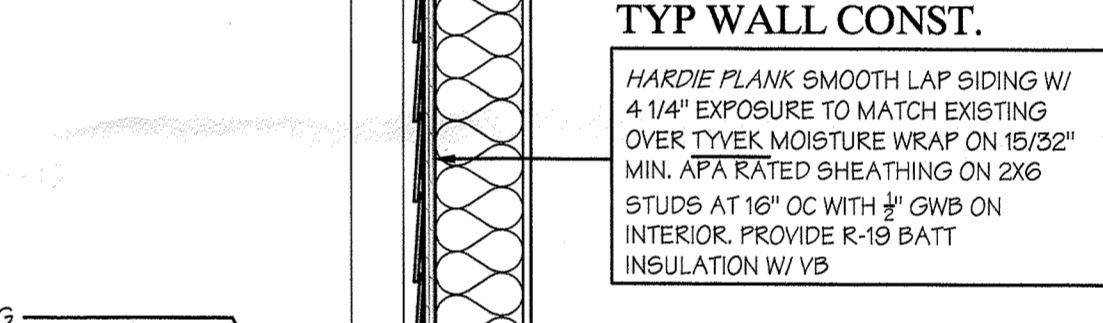

TYP WALL CONST.

HARDIE PLANK SMOOTH LAP SIDING W/ 4-1/4" EXPOSURE TO MATCH EXISTING OVER TTYEK MOISTURE WRAP ON 15/32" MIN. APA RATED SHEATHING ON 2x6 STUDS AT 16" OC WITH 3/8" GWB ON INTERIOR. PROVIDE R-19 BATT INSULATION W/ V.B.

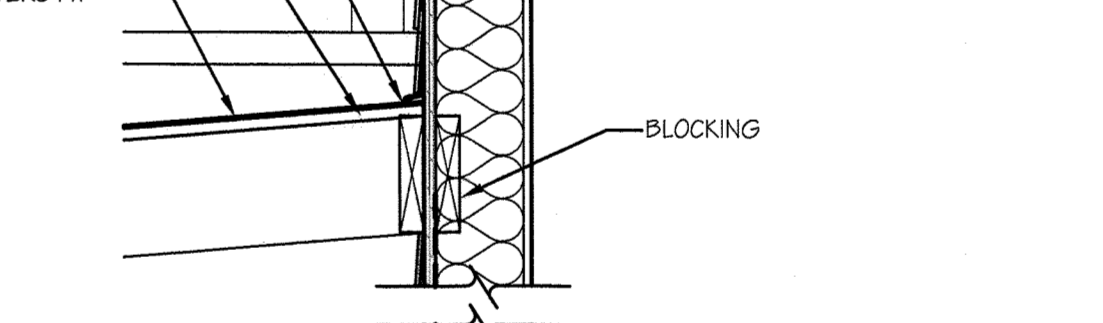

TYP WALL CONST.

3/4" T&G ROOF SHEATHING OVER 2x8 RAFTERS AT 16" OC

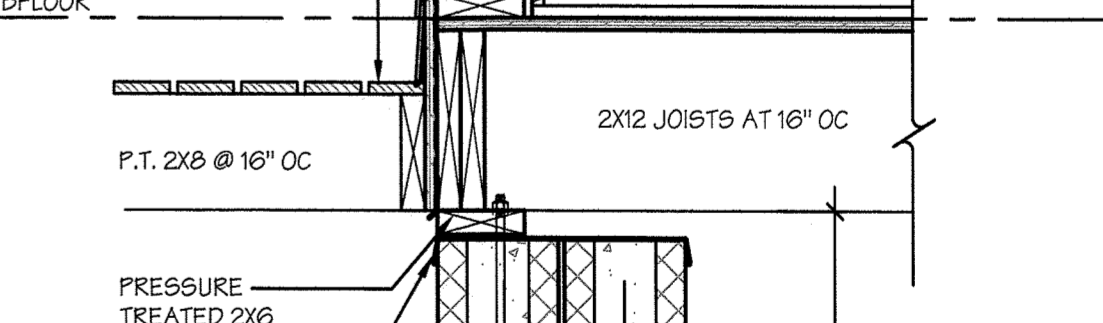

TYP WALL CONST.

16" AUGER PIER DRILLED INTO CAP ROCK. USE 4 #4 VERTICAL BARS W/ #3 TIES @ 12" o.c. FULL HT.

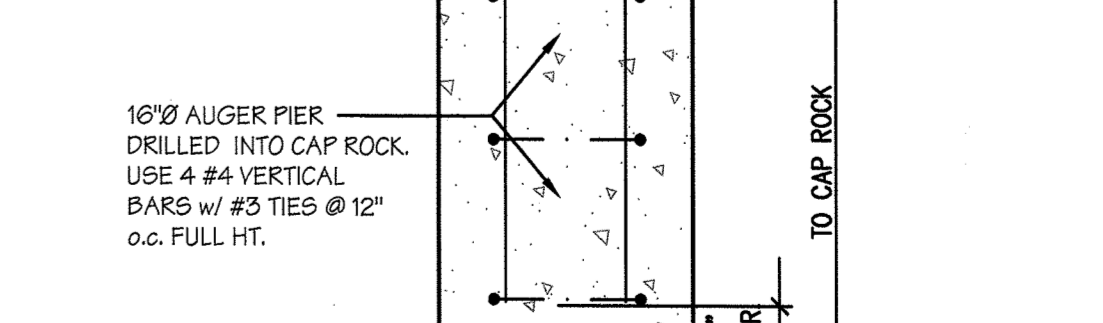

TYP WALL CONST.

16" AUGER PIER DRILLED INTO CAP ROCK. USE 4 #4 VERTICAL BARS W/ #3 TIES @ 12" o.c. FULL HT.

TYP ROOF CONST.

V-CRIMP METAL ROOFING TO MATCH EXISTING ON 30# ROOFING FELT OVER 3/2" APA RATED PLYWD. SHEATHING ON 2x8 ROOF RAFTERS @ 24" o.c.

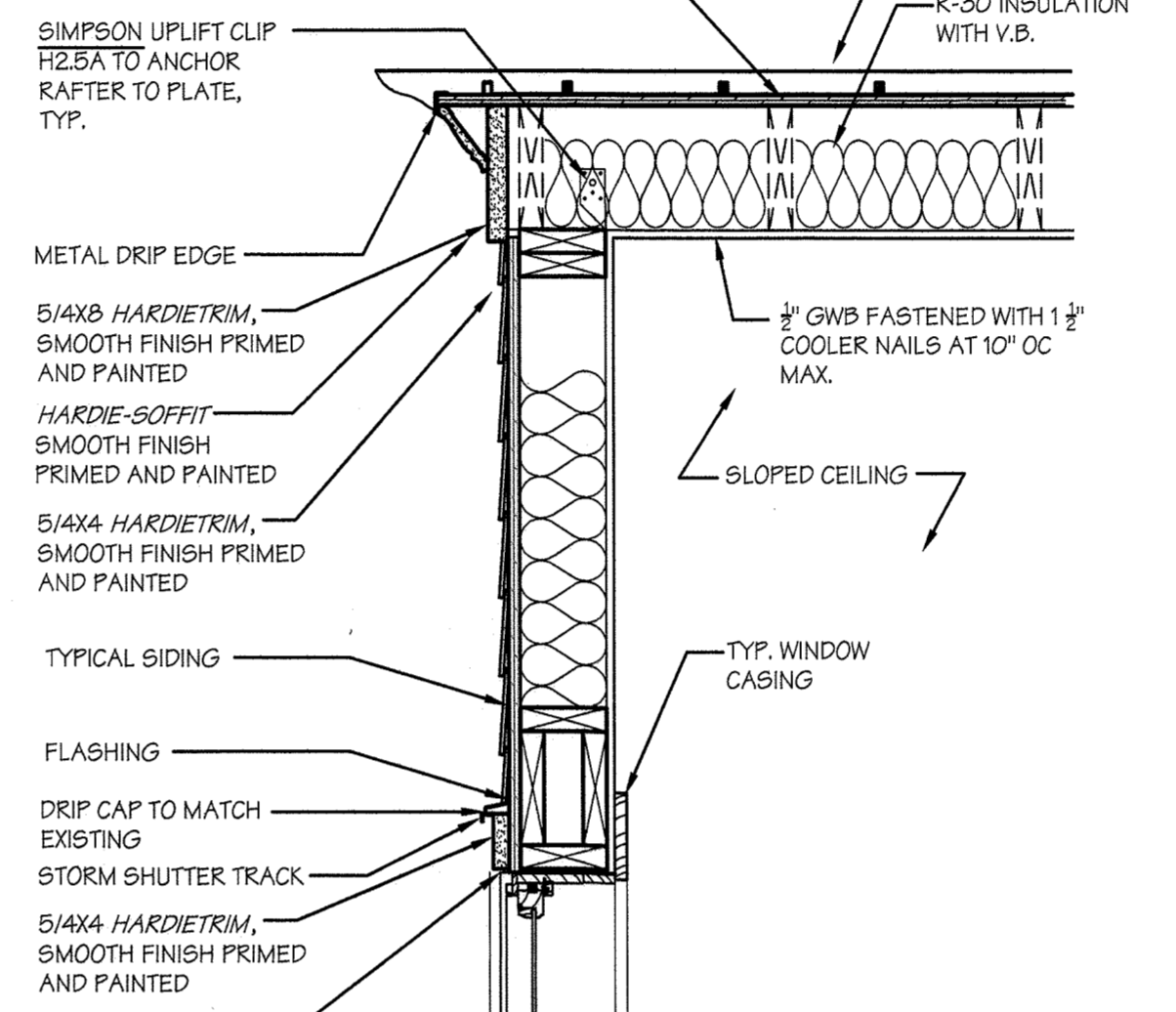

TYP WALL CONST.

HARDIE PLANK SMOOTH LAP SIDING TO MATCH EXISTING OVER TTYEK MOISTURE WRAP ON 15/32" MIN. APA RATED SHEATHING ON 2x6 STUDS AT 16" OC WITH 3/8" GWB ON INTERIOR. PROVIDE R-19 BATT INSULATION W/ V.B.

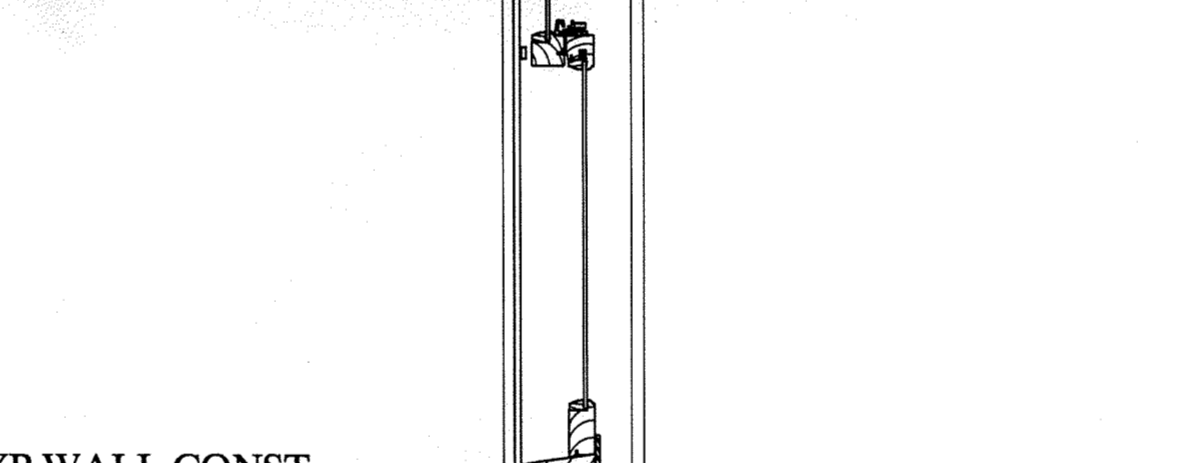

TYP WALL CONST.

16" AUGER PIER DRILLED INTO CAP ROCK. USE 4 #4 VERTICAL BARS W/ #3 TIES @ 12" o.c. FULL HT.

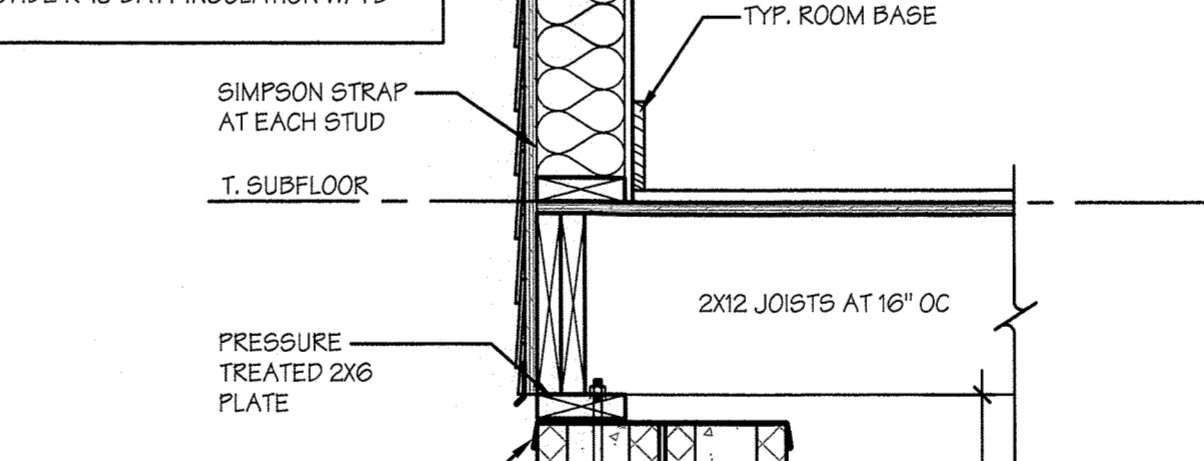

TYP WALL CONST.

16" AUGER PIER DRILLED INTO CAP ROCK. USE 4 #4 VERTICAL BARS W/ #3 TIES @ 12" o.c. FULL HT.

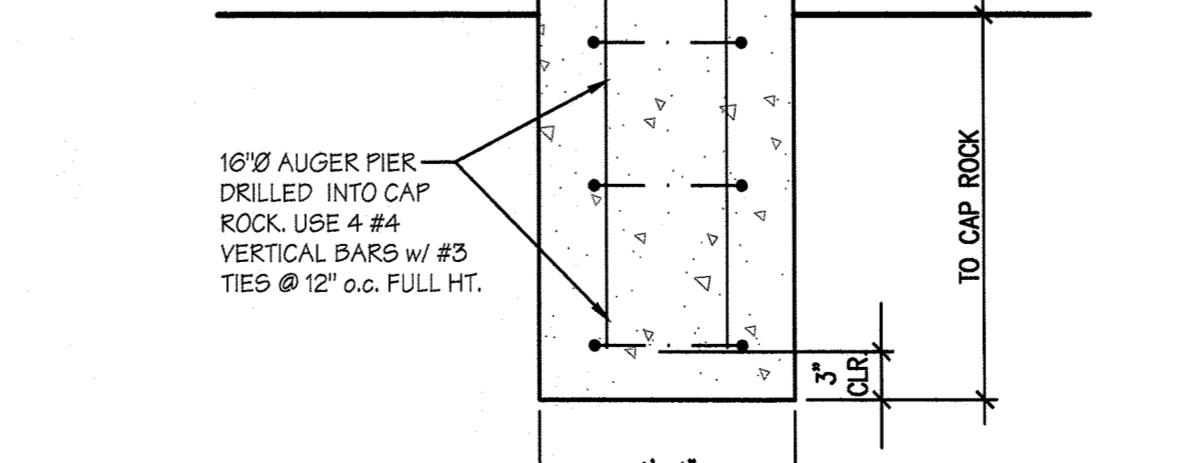

TYP WALL CONST.

16" AUGER PIER DRILLED INTO CAP ROCK. USE 4 #4 VERTICAL BARS W/ #3 TIES @ 12" o.c. FULL HT.

VENTILATE ATTIC SPACE WITH (2) 51 SQ. IN. ATTIC VENTS

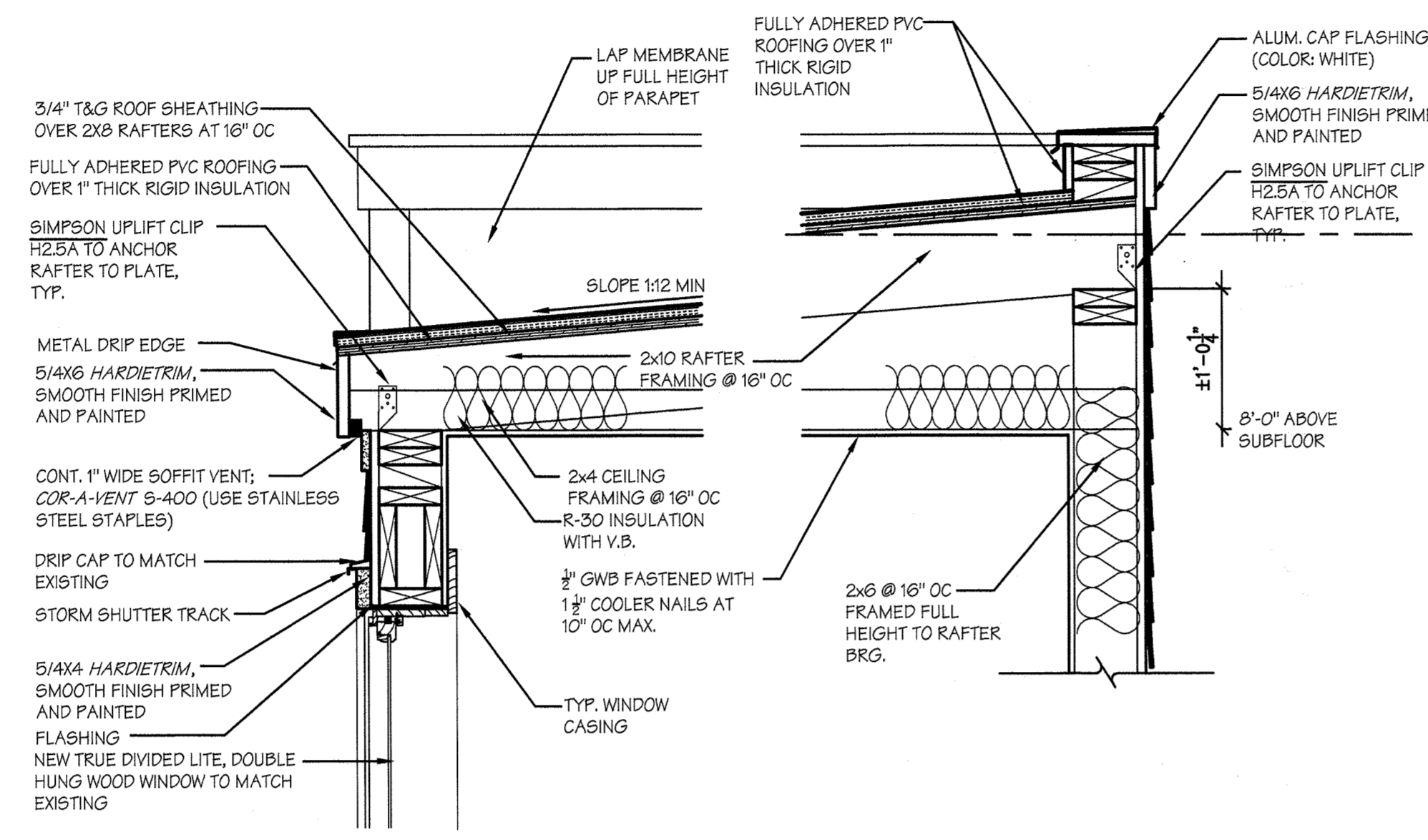

5 Wall Section Detail
SCALE: 1" = 1'-0"

TYP WALL CONST.

HARDIE PLANK SMOOTH LAP SIDING W/ 4-1/4" EXPOSURE TO MATCH EXISTING OVER TTYEK MOISTURE WRAP ON 15/32" MIN. APA RATED SHEATHING ON 2x6 STUDS AT 16" OC WITH 3/8" GWB ON INTERIOR. PROVIDE R-19 BATT INSULATION W/ V.B.

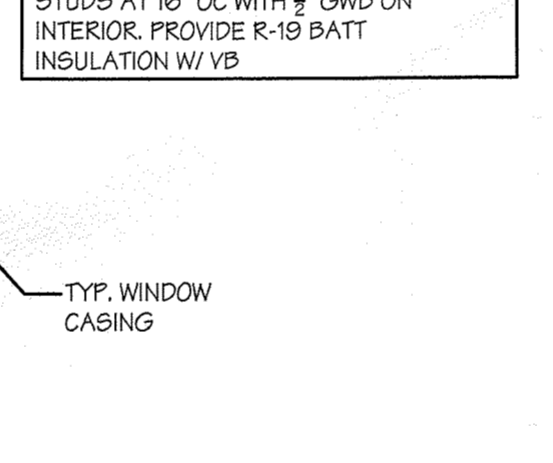

TYP WALL CONST.

16" AUGER PIER DRILLED INTO CAP ROCK. USE 4 #4 VERTICAL BARS W/ #3 TIES @ 12" o.c. FULL HT.



TYP WALL CONST.

16" AUGER PIER DRILLED INTO CAP ROCK. USE 4 #4 VERTICAL BARS W/ #3 TIES @ 12" o.c. FULL HT.

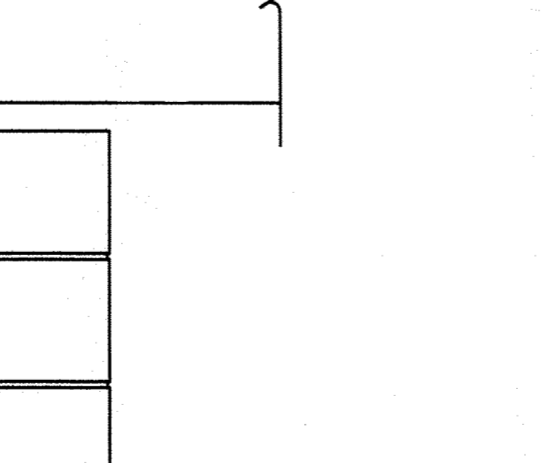

TYP WALL CONST.

16" AUGER PIER DRILLED INTO CAP ROCK. USE 4 #4 VERTICAL BARS W/ #3 TIES @ 12" o.c. FULL HT.

TYP ROOF CONST.

V-CRIMP METAL ROOFING TO MATCH EXISTING ON 30# ROOFING FELT OVER 3/2" APA RATED PLYWD. SHEATHING ON 2x8 ROOF RAFTERS @ 24" o.c.

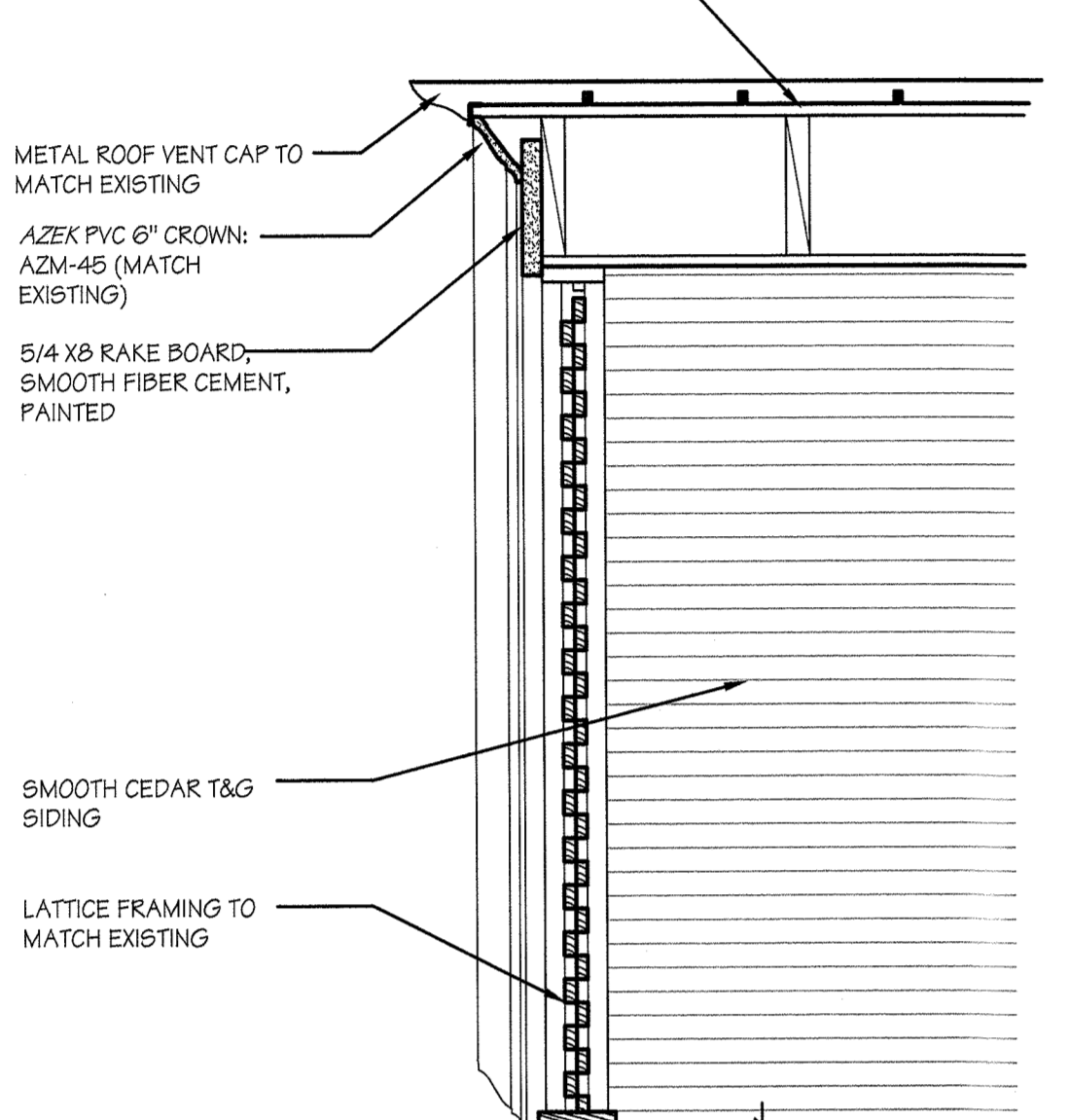

TYP ROOF CONST.

V-CRIMP METAL ROOFING TO MATCH EXISTING ON 30# ROOFING FELT OVER 3/2" APA RATED PLYWD. SHEATHING ON 2x8 ROOF RAFTERS @ 24" o.c.

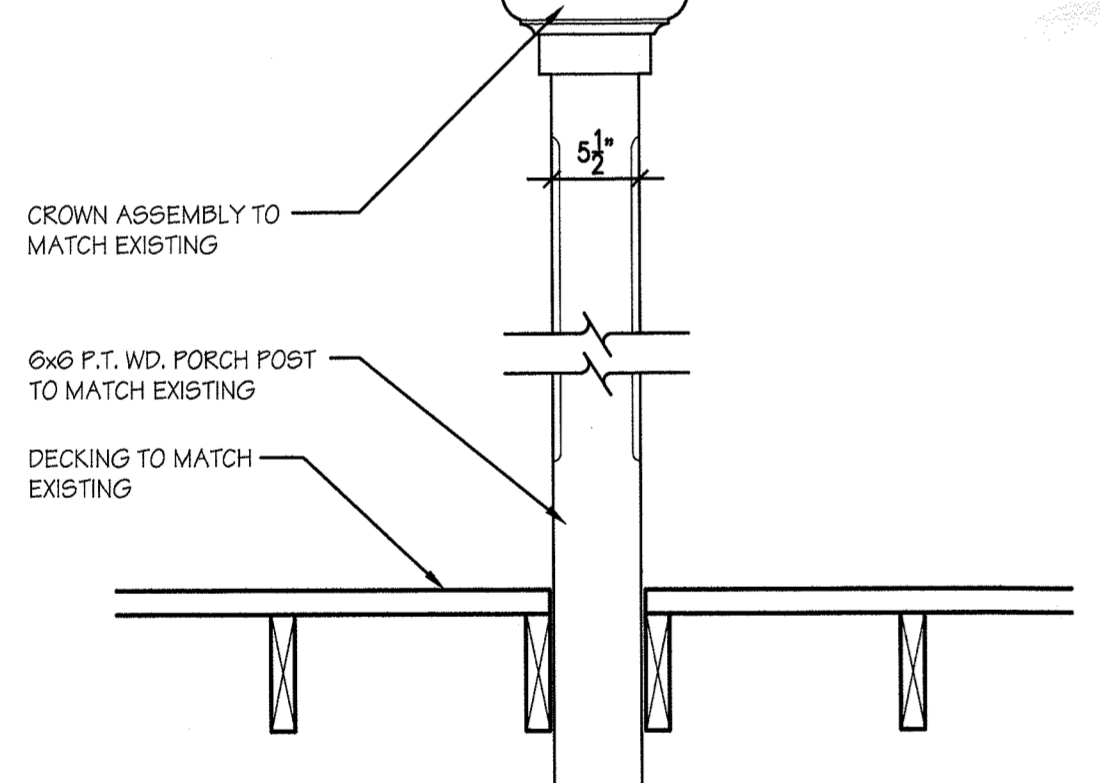

TYP ROOF CONST.

V-CRIMP METAL ROOFING TO MATCH EXISTING ON 30# ROOFING FELT OVER 3/2" APA RATED PLYWD. SHEATHING ON 2x8 ROOF RAFTERS @ 24" o.c.

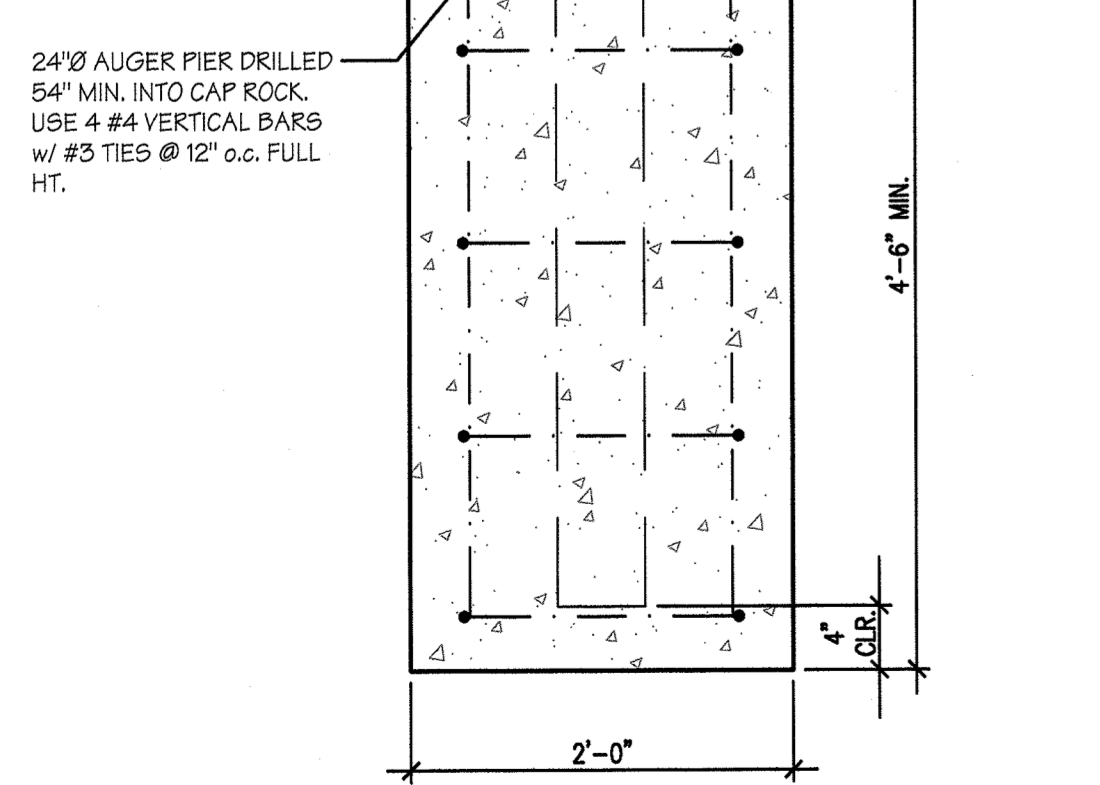

TYP ROOF CONST.

V-CRIMP METAL ROOFING TO MATCH EXISTING ON 30# ROOFING FELT OVER 3/2" APA RATED PLYWD. SHEATHING ON 2x8 ROOF RAFTERS @ 24" o.c.

4 POST FOUNDATION DETAIL
SCALE: 1" = 1'-0"

3 WALL DETAIL
SCALE: 1" = 1'-0"

2 WALL DETAIL
SCALE: 1" = 1'-0"

1 WALL DETAIL
SCALE: 1" = 1'-0"



WALL COLOR
(matches existing)

arctic shadows
1559

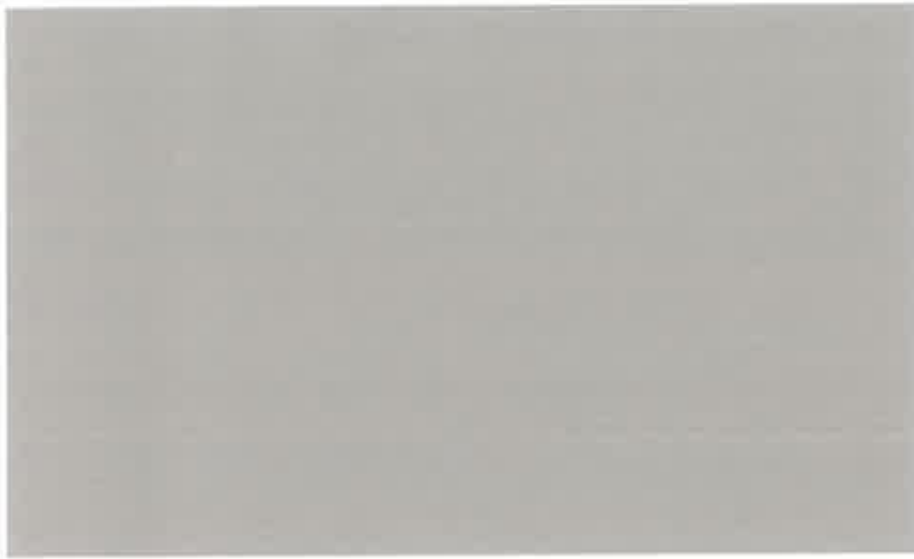

This color is part of the Classic Color Collection. Surround yourself with your color favorites. These timeless, elegant, Classic Colors guarantee beautiful, usable color all the time, every time. A collection of 1,680 inspired hues that consumers and professionals have enjoyed for years, the colors in this palette are as timeless as they are forward.

GOES GREAT WITH



SIMILAR COLORS



MORE SHADES





TRIM COLOR
(matches existing)
decorators white
CC-20

This color is part of the Designer Classics Collection. Comfortable colors that can be chosen with confidence. The Designer Classics palette features 231 tried-and-true colors - timeless beauty you can integrate into a variety of design styles and decors. A perennial favorite of both discerning consumers and professional designers alike, Designer Classics are colors you can choose with confidence to enhance the mood and atmosphere of any living space.

GOES GREAT WITH



SIMILAR COLORS

MORE SHADES





Windows:

Marvin Wood Ultimate Double Hung with single-pane, true divided lites

DOOR TYPE A



[Print](#)



Primed Flat Panel

8020

Series: [Redi-Prime® Doors](#)

Type: Interior Panel

Standard Features

[Available in Any Wood Species](#)

Available in Virtually Any Size

Panels: 3/8" Hardboard Flat Panel

Moulding: na

Glass: na

Caming: na

Customer Service: 1-800-SIMPSON (746-7766)

Email: SimpsonCustomerService@brandner.com

DOOR TYPE B

Simpson®
Door Company

Print

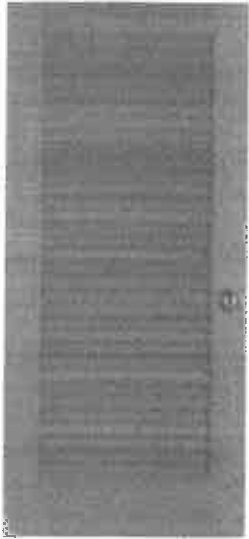

Plantation Louver Doors

8420

Series: Interior Panel

Type: Interior Panel

Standard Features

Available in Any Wood Species

Available in Virtually Any Size

Panels: 2-1/4" Wide Plantation Louver Slats

Moulding: na

Glass: na

Caming: na

Customer Service: 1-800-SIMPSON (746-7766)

Email: SimpsonCustomerService@brandner.com

DOOR TYPE C

Simpson®
Door Company

Print



Traditional

2010

Series: Exterior Traditional

Type: Exterior Traditional

Standard Features

Available in Any Wood Species

Available in Virtually Any Size

Available with UltraBlock® Technology.

5-year warranty

Panels: 3/4" Double Hip-Raised Panel

Moulding: na

Glass: na

Caming: na

Customer Service: 1-800-SIMPSON (746-7766)

Email: SimpsonCustomerService@brandner.com

DOOR TYPE D



[Print](#)



Exterior French

1510

Series: [Exterior French & Sash](#)

Type: Exterior French & Sash

Standard Features

[Available in Any Wood Species](#)

Available in Virtually Any Size

[Textured Glass Options](#)

[Try the Glass Taste Test](#)

[Available with UltraBlock® Technology,](#)

[5-year warranty](#)

Privacy Rating: 1

Panels: na

Moulding: na

Glass: 1/8" Single Glazed

Caming: na

[View Insulated Glazing \(IG\) version](#)

Customer Service: 1-800-SIMPSON (746-7766)

Email: SimpsonCustomerService@brandner.com

DOOR TYPE E



[Print](#)



Exterior French

1515

Series: [Exterior French & Sash](#)

Type: Exterior French & Sash

Standard Features

[Available in Any Wood Species](#)

Available in Virtually Any Size

[Textured Glass Options](#)

[Try the Glass Taste Test](#)

[Available with UltraBlock® Technology,](#)

[5-year warranty](#)

Privacy Rating: 1

Panels: na

Moulding: na

Glass: 1/8" Single Glazed

Caming: na

[View Insulated Glazing \(IG\) version](#)

Customer Service: 1-800-SIMPSON (746-7766)

Email: SimpsonCustomerService@brandner.com

BALDWIN

5105 ESTATE LEVER

SPECIFICATIONS

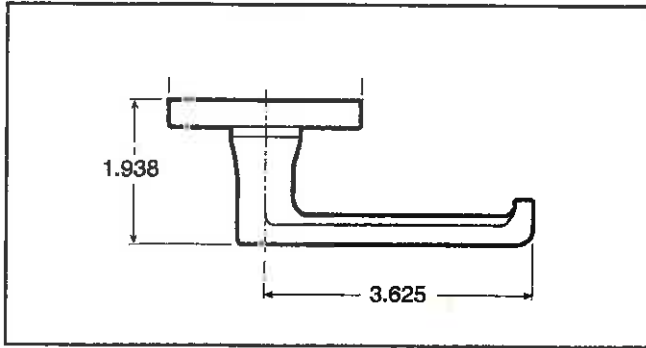

- > Accessibility Code (ADA) A117.1 for all levers.
- > Certified by Underwriters Laboratories (UL) for use on fire doors up to three-hour rating
- > U L10C / UBC 7-2 (1997) Positive Pressure Rated, UL10B Pressure Rated
- > Material: Solid Brass

5105.102

SHOWN WITH ROSE 5006

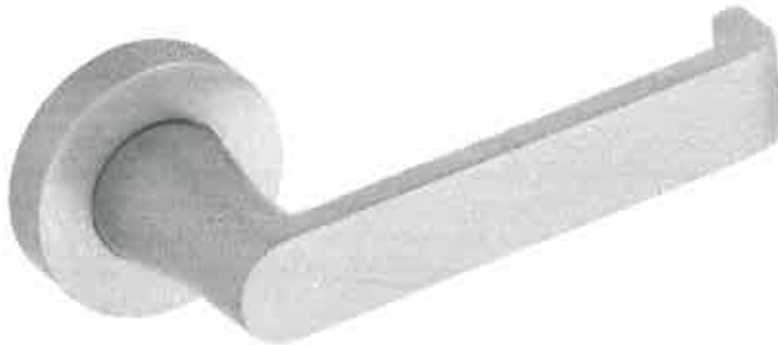

TIER 1 FINISHES



TIER 2 FINISHES

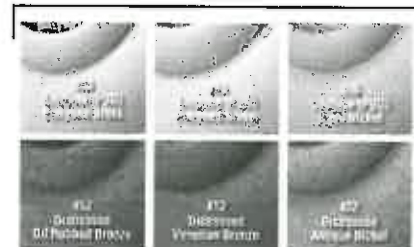

Noticing

Public Meeting Notice

The Historic Architectural Review Commission will hold a public hearing at 5:30 p.m., May 27, 2014 at Old City Hall, 510 Greene Street, Key West, Florida. The purpose of the hearing will be to consider a request for:

NEW ONE STORY BACK EXTENSION AND NEW ONE STORY SIDE ADDITION. DEMOLITION OF NON-HISTORIC BACK ADDITION.

FOR- #2 GECKO LANE

Applicant- Donald Beck, Architect and Owner

Application # H14-01-0579

If you wish to see the application or have any questions, you may visit the Planning Department during regular office hours at 3140 Flagler Avenue, call 809-3973 or visit our website at www.keywestcity.com.

THIS NOTICE CAN NOT BE REMOVED FROM THE SITE UNTIL HARC FINAL DETERMINATION

**Property Appraiser
Information**



Scott P. Russell, CFA
Property Appraiser
Monroe County, Florida

Key West (305) 292-3420
 Marathon (305) 289-2550
 Plantation Key (305) 852-7130

Property Record Card -
Maps are now launching the new map application version.

Website tested on IE8,
 IE9, & Firefox.
 Requires Adobe Flash
 10.3 or higher

Alternate Key: 1003166 Parcel ID: 00003070-000000

Ownership Details

Mailing Address:
 EYNON LAWRENCE E MD
 550 LIBERTY HL
 CINCINNATI, OH 45202-6891

All Owners:
 BECK DONALD S R/S, EYNON LAWRENCE E MD

Property Details

PC Code: 08 - MULTI FAMILY LESS THAN 10UNITS
Millage Group: 10KW
Affordable Housing: No
Section-Township-Range: 06-68-25
Property Location: 2 GECKO LN KEY WEST
Legal Description: KW PT LOT 1 SQR 21 H3-227 OR526-892D/C OR870-2185/86 OR870-2187 OR988-1898/99 OR988-1900/01 OR1090-2445/46R/S OR1090-2447/48 OR2676-642/50

Click Map Image to open interactive viewer

Land Details

Land Use Code	Frontage	Depth	Land Area
01LN - SFR LANE	49	91	4,026.00 SF

Building Summary

Number of Buildings: 2
Number of Commercial Buildings: 0
Total Living Area: 1837
Year Built: 1935

Building 1 Details

Building Type R1
Effective Age 16

Condition G
Perimeter 196

Quality Grade 550
Depreciation % 18

Year Built 1935
Functional Obs 0

Special Arch 0
Economic Obs 0

Grnd Floor Area 888

Inclusions: R1 includes 1 3-fixture bath and 1 kitchen.

Roof Type GABLE/HIP

Roof Cover METAL

Foundation CONC BLOCK

Heat 1 FCD/AIR DUCTED

Heat 2 NONE

Bedrooms 1

Heat Src 1 ELECTRIC

Heat Src 2 NONE

Extra Features:

2 Fix Bath 0
3 Fix Bath 0
4 Fix Bath 0
5 Fix Bath 0
6 Fix Bath 0
7 Fix Bath 0
Extra Fix 0

Vacuum 0
Garbage Disposal 0
Compactor 0
Security 0
Intercom 0
Fireplaces 0
Dishwasher 0

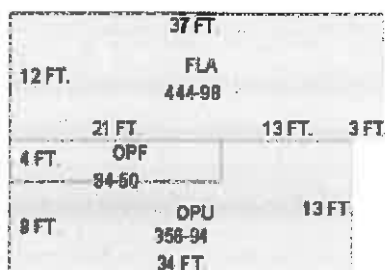

Sections:

Nbr	Type	Ext Wall	# Stories	Year Built	Attic A/C	Basement %	Finished Basement %	Area
1	FLA	12:ABOVE AVERAGE WOOD	1	1990	N Y	0.00	0.00	444
2	OPF		1	1990	N N	0.00	0.00	84
3	OPU		1	1990	N N	0.00	0.00	358
4	FLA	12:ABOVE AVERAGE WOOD	1	1990	N Y	0.00	0.00	444

Building 2 Details

Building Type R1
Effective Age 18
Year Built 1935

Condition A
Perimeter 140
Special Arch 0

Quality Grade 550
Depreciation % 24
Grnd Floor Area 949

Functional Obs 0

Economic Obs 0

Inclusions: R1 includes 1 3-fixture bath and 1 kitchen.

Roof Type GABLE/HIP

Roof Cover METAL

Foundation CONC BLOCK

Heat 1 NONE

Heat 2 NONE

Bedrooms 2

Heat Src 1 NONE

Heat Src 2 NONE

Extra Features:

2 Fix Bath 0
 3 Fix Bath 1
 4 Fix Bath 0
 5 Fix Bath 0
 6 Fix Bath 0
 7 Fix Bath 0
 Extra Fix 0

Vacuum 0
 Garbage Disposal 0
 Compactor 0
 Security 1
 Intercom 0
 Fireplaces 0
 Dishwasher 0

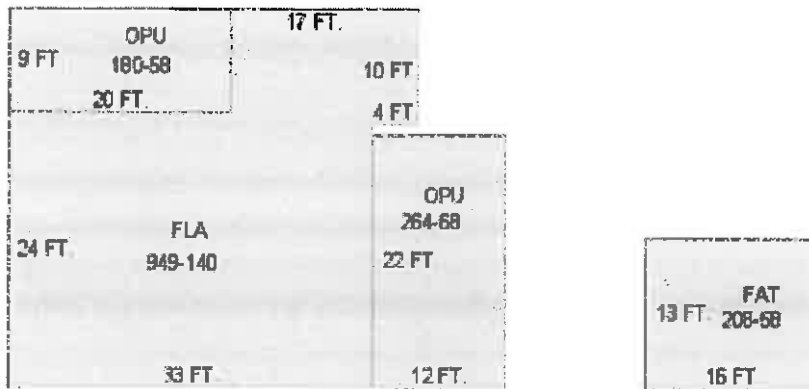

Sections:

Nbr	Type	Ext Wall	# Stories	Year Built	Attic A/C	Basement %	Finished Basement %	Area
1	FLA	12:ABOVE AVERAGE WOOD	1	1990	N N	0.00	0.00	949
2	OPU		1	1990	N N	0.00	0.00	180
3	OPU		1	1990	N N	0.00	0.00	264
4	FAT	12:ABOVE AVERAGE WOOD	1	1990	N N	0.00	0.00	208

Misc Improvement Details

Nbr	Type	# Units	Length	Width	Year Built	Roll Year	Grade	Life
1	HT2:HOT TUB	1 UT	0	0	1983	1984	3	50
2	AC2:WALL AIR COND	2 UT	0	0	1983	1984	2	20

3	FN2:FENCES	119 SF	17	7	1975	1976	5	30
4	FN2:FENCES	368 SF	46	8	1987	1988	5	30
5	FN2:FENCES	621 SF	69	9	1987	1988	5	30
6	PO4:RES POOL	181 SF	0	0	1989	1990	5	50

Appraiser Notes

AKA #2 & 3 GECKO LANE

Building Permits

Bldg Number	Date Issued	Date Completed	Amount	Description	Notes	
13-0058	01/08/2013		10,006	Residential	INSTALL 800 SQ FT (8 SQS) OF 26 GALVALUME V-CRIMP METAL ROOFING	
1	B95-3972	11/01/1995	12/01/1995	2,600	Residential	REPAIRS & PAINT
2	06-5501	10/03/2006	12/11/2006	2,200	Residential	CHANGE OUT ONE 3.5 TON CONDENSOR
3	07-1043	03/15/2007	12/29/2008	24,500	Residential	REPAIR 1000SF OF DECKING & ROOFING IN THE REAR
4	07-2187	05/07/2007	12/29/2008	3,875	Residential	INSTALL 600SF OF V-CRIMP ROOFING AND NEW DORMER

Parcel Value History

Certified Roll Values.

[View Taxes for this Parcel.](#)

Roll Year	Total Bldg Value	Total Misc Improvement Value	Total Land Value	Total Just (Market) Value	Total Assessed Value	School Exempt Value	School Taxable Value
2013	251,968	18,256	240,545	510,769	449,590	0	510,769
2012	259,593	18,791	130,335	408,719	408,719	0	408,719
2011	262,700	19,325	180,445	462,470	462,470	0	462,470
2010	265,807	19,860	166,411	452,078	452,078	0	452,078
2009	297,165	20,394	341,149	658,708	658,708	0	658,708
2008	273,254	20,929	402,600	696,783	696,783	0	696,783
2007	361,346	18,328	664,290	1,043,964	1,043,964	0	1,043,964
2006	605,552	18,767	382,470	1,006,789	1,006,789	0	1,006,789
2005	619,548	19,503	305,976	945,027	945,027	0	945,027
2004	352,285	20,339	285,846	658,470	658,470	0	658,470
2003	339,238	21,075	152,988	513,301	513,301	0	513,301
2002	321,369	21,810	140,910	484,089	484,089	0	484,089
2001	254,606	22,647	169,092	446,345	446,345	0	446,345
2000	274,517	22,938	97,832	395,286	395,286	0	395,286
1999	261,387	22,467	97,832	381,687	381,687	0	381,687
1998	220,807	19,555	97,832	338,193	338,193	0	338,193
1997	202,903	18,455	88,169	309,528	309,528	0	309,528

1996	161,129	15,043	88,169	264,341	264,341	0	264,341
1995	155,162	14,954	88,169	258,284	258,284	0	258,284
1994	131,290	13,023	88,169	232,482	232,482	0	232,482
1993	141,013	13,402	88,169	242,585	242,585	0	242,585
1992	141,013	13,812	88,169	242,994	242,994	0	242,994
1991	141,013	14,192	88,169	243,375	243,375	0	243,375
1990	127,155	10,074	73,676	210,904	210,904	0	210,904
1989	158,114	9,418	72,468	240,000	240,000	0	240,000
1988	129,615	8,524	72,468	210,607	210,607	0	210,607
1987	128,188	8,755	37,241	174,184	174,184	0	174,184
1986	40,748	1,995	36,234	78,977	78,977	0	78,977
1985	39,614	1,995	16,496	58,105	58,105	0	58,105
1984	37,112	1,995	16,496	55,603	55,603	0	55,603
1983	37,112	1,995	16,496	55,603	55,603	0	55,603
1982	19,772	1,995	14,334	36,101	36,101	25,500	10,601

Parcel Sales History

NOTE: Sales do not generally show up in our computer system until about two to three months after the date of sale. If a recent sale does not show up in this list, please allow more time for the sale record to be processed. Thank you for your patience and understanding.

Sale Date	Official Records Book/Page	Price	Instrument	Qualification
5/1/1989	1090 / 2445	300,000	WD	Q
8/1/1986	988 / 1898	223,000	WD	Q
12/1/1982	870 / 2185	75,000	WD	Q

This page has been visited 126,454 times.

Monroe County Monroe County Property Appraiser
 Scott P. Russell, CFA
 P.O. Box 1176 Key West, FL 33041-1176