

NOTE TO BIDDER: Use preferably BLACK ink for completing this Bid form.

**BID FORM**

To: The City of Key West

Address: 3140 Flagler Ave, Key West, Florida 33040

Project Title: Ornamental Fencing Replacement NASKW

City of Key West Project No.: ITB 12-029

Bidder's contact for additional information on this Bid: \_\_\_\_\_

Company Name: Douglas N. Higgins, Inc.

Contact Name: Daniel Higgins

Telephone: (734) 996-9500

**BIDDER'S DECLARATION AND UNDERSTANDING**

The undersigned, hereinafter called the Bidder, declares that the only persons or parties interested in this Bid are those named herein, that this Bid is, in all respects, fair and without fraud, that it is made without collusion with any official of the Owner, and that the Bid is made without any connection or collusion with any person submitting another Bid on this Contract.

The Bidder further declares that he has carefully examined the Contract Documents for the construction of the project, that he has personally inspected the site, that he has satisfied himself as to the quantities involved, including materials and equipment, and conditions of work involved, including the fact that the description of the quantities of work and materials, as included herein, is brief and is intended only to indicate the general nature of the Work and to identify the said quantities with the detailed requirements of the Contract Documents, and that this Bid is made according to the provisions and under the terms of the Contract Documents, which Documents are hereby made a part of this Bid.

The Bidder further agrees, as evidenced by signing the Bid, that if awarded a Contract, the Florida Trench Safety Act and applicable trench safety standards will be complied with.

**CONTRACT EXECUTION AND BONDS**

The Bidder agrees that if this Bid is accepted, he will, within 10 days, not including Sundays and legal holidays, after Notice of Award, sign the Contract in the form annexed hereto, and will at that time, deliver to the Owner examples of the Performance Bond and Payment Bond required herein, and evidence of holding required licenses and certificates, and will, to the extent of his Bid, furnish all machinery, tools, apparatus, and other means of construction and do the Work and furnish all the materials necessary to complete all work as specified or indicated in the Contract Documents.

JULY 16, 2012

BID FORM

00 41 13 - 1

CERTIFICATES OF INSURANCE

Bidder agrees to furnish the Owner, before commencing the Work under this Contract, the certificates of insurance as specified in these Documents.

START OF CONSTRUCTION AND CONTRACT COMPLETION TIMES

The Bidder agrees to begin work within 10 calendar days after the date of the Notice to Proceed and to achieve Substantial Completion within 150 calendar days from the date when the Contract Times commence to run as provided in paragraph 2.03.A of the General Conditions, and Work will be completed and ready for final payment and acceptance in accordance with paragraph 14.07 of the General Conditions within 150 calendar days from the date when the Contract Times commence to run.

LIQUIDATED DAMAGES

In the event the Bidder is awarded the Contract, Owner and Bidder recognize that time is of the essence of this Agreement and that Owner will suffer financial loss if the Work is not completed within the times specified in paragraph Start of Construction and Contract Completion Times above, plus any extensions thereof allowed in accordance with Article 12.03 of the General Conditions. Owner and Bidder also recognize the delays, expense, and difficulties involved in proving in a legal or other dispute resolution proceeding the actual loss suffered by Owner if the Work is not completed on time. Accordingly, instead of requiring any such proof, Owner and Bidder agree that as liquidated damages for delay (but not as a penalty) Bidder shall pay Owner \$200 per day for each day that expires after the time specified for substantial completion.

After Substantial Completion, if Bidder neglects, refuses, or fails to complete the remaining Work within the Contract Times or any Owner-granted extension thereof, Bidder shall pay Owner \$200 for each day that expires after the time specified in paragraph Start of Construction and Contract Completion Times, above for completion and readiness for final payment. Liquidated damages shall run concurrent.

Owner will recover such liquidated damages by deducting the amount owed from the final payment or any retainage held by Owner.

ADDENDA

The Bidder hereby acknowledges that he has received Addenda Nos. 1, 2, \_\_\_\_\_, \_\_\_\_\_, \_\_\_\_\_ (Bidder shall insert No. of each Addendum received) and agrees that all addenda issued are hereby made part of the Contract Documents, and the Bidder further agrees that his Bid(s) includes all impacts resulting from said addenda.

SALES AND USE TAXES

The Bidder agrees that all federal, state, and local sales and use taxes are included in the stated Bid Prices for the Work. Cash allowances DO NOT include any sales and use tax. Equipment allowance includes taxes as shown in Equipment Suppliers' Bids.



**THE CITY OF KEY WEST**  
3140 Flagler St,  
Key West, Florida 330-40

**ADDENDUM #1**  
**Ornamental Fencing Replacement**  
**Invitation to Bid: 12-029**  
**13 July 2012**

This Addendum is issued as supplemental information to the bid package for clarification of certain matters of both a general and a technical nature. The referenced bid package is amended in accordance with the following items:

1. The Engineering cost estimate for this project is \$1,600,000 dollars.
2. A valid, current Florida Contractors License is required under this contract. Proof shall be submitted with the bid.
3. A single Right Of Way Permit (\$50) is required under this project to cover all locations. Contractor shall evaluate each location and develop a MOT program.
4. Contractor is to be aware that while working on the mole a cruise ship may be present. Contractor's efforts shall not impede traffic flow while a cruise ship is present.
5. All Contractor and subcontractor employees working on the project sites shall be in possession of a Rapid Pass ID Card. Contractor shall include in his bid cost to obtain.
6. Aerial: Replace the site location aerials with those the attached.
7. Estimated Quantities for Fencing Repair ITB 12-029: Delete this sheet.
8. Bid Sheet: A revised bid sheet is attached.
9. From September 12 to September 21, 2012 the U.S. Navy will be holding a UNTAS Exercise at the Mole. No work will be permitted in the Mole Port Operations Area during this time. No temporary fencing will be allowed to secure the Mole Port Operations Area during this period.
10. In November 2012 the annual Power Boat Races (1 week) will occur and no work will be permitted at the Mole Port Operations area. No temporary fencing will be allowed to secure the Mole Port Operations area during this period.
11. Contractor is responsible for clearing as required to access work. Established landscaping shall be returned to its original condition. Mangroves shall be tied

back out of work area or a trimming permit received from the required agencies at the cost of the contractor.

12. Temporary fencing that is required to remain overnight to secure an area shall have top and bottom rails, 8 feet in height and verticals embedded 2 feet deep in concrete.
13. Contractor shall be required to install sufficient intermediate posts to ensure that the installed fencing will meet the 140mph wind load requirement. Contractor shall contact manufacturer to determine maximum span before an intermediate post is required
14. Fence Anchors: shall have a minimum embedment depth of 4 inches and shall be 3/8" diameter
15. Fence Anchors: Existing Fence anchors and other mounting hardware (section 14) shall be completely removed or cut back in such a way that a minimum of 1-3/4" of concrete cover is provided in addition to the stucco finish. Restoration of area around additional anchors after anchor removal is NOT considered a spall repair.
16. At the junction of Section 12 and Section 13, there is a curved portion of fencing at this location. This section may be replaced with a straight section.
17. Salvage: Contractor shall carefully remove 1,500 lf of fencing (to be determined) by the City and deliver to a designated storage site within the City Of Key West
18. Paint: Paint for concrete works shall be Sherwin-Williams A-100 Exterior Acrylic Latex Paint (or equivalent): Bright White
19. Privacy Mesh: Shall be installed on sections 3, 11 and 12. See following website: <http://www.fencescreen.com/Products/200-Series-Privacy-Screen.aspx> Color: Black
20. Concrete Works: The concrete curb to be installed on section 10 shall match the existing concrete curb on the adjacent section 8. The curb shall have two #4 rebar with 3 inches of concrete cover. See detail on Sheet C-5 (Detail 10.1)
21. Concrete Caps: All existing caps in section 5A shall be removed and replaced with the caps shown on Sheet C-5 (Details 4.1 and 4.2)
22. Concrete Works: Contractor will be required to perform curb repairs along section 1 in accordance with the attached detail shown on Sheet C-6. Contractor shall identify defective concrete and quantities and verify with the City's Representative.

All Bidders shall acknowledge receipt and acceptance of this Addendum No 5 by acknowledging Addendum in their proposal or by submitting the addendum with the bid package. Bids submitted without acknowledgement or without this Addendum may be considered non-responsive

  
\_\_\_\_\_  
Signature

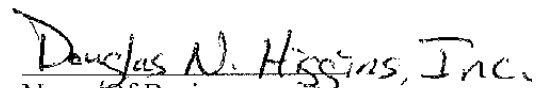
  
\_\_\_\_\_  
Name Of Business



**THE CITY OF KEY WEST**  
 3140 Flagler St,  
 Key West, Florida 330-40

**ADDENDUM #2**  
**Ornamental Fencing Replacement**  
**Invitation to Bid: 12-029**  
**16 July 2012**

This Addendum is issued as supplemental information to the bid package for clarification of certain matters of both a general and a technical nature. The referenced bid package is amended in accordance with the following items:

1. Replace the Bid Form (9 pages) with the one attached.
  - a. Spalling repairs: changed units from SF to CF.
  - b. Quantity of pilasters Section 14 is corrected.
2. Bidders' attention is called to the fact that this ITB provides estimated quantities. Payment will be based on actual quantities as verified in the field.
3. Intermediate metal posts being removed shall be removed to a minimum of 4" below grade or 4" below existing concrete surface.
4. Bidder may meet the "licensed contractor" requirement by submitting a certificate of competency issued by the City of Key West Chief Building Official which will require certification by another Florida county or municipality with which the City of Key West maintains a reciprocity agreement. In such case, the bidder must also submit a valid City of Key West Business Tax License receipt, the cost of which is to be borne by the bidder.

All Bidders shall acknowledge receipt and acceptance of this Addendum No 2 by acknowledging Addendum in their proposal or by submitting the addendum with the bid package. Bids submitted without acknowledgement or without this Addendum may be considered non-responsive.

  
 Signature

  
 Name Of Business

PUBLIC ENTITY CRIMES

“A person or affiliate who has been placed on the convicted vendor list following a conviction for a public entity crime may not submit a bid on a contract to provide any goods or services to a public entity, may not submit a bid on a contract with a public entity for the construction or repair of a public building or public work, may not submit bids on leases of real property to a public entity, may not be awarded or perform work as a contractor, supplier, subcontractor, or consultant under a contract with any public entity and may not transact business with any public entity in excess of the threshold amount provided in Section 287.017, for CATEGORY TWO for a period of 36 months from the date of being placed on the convicted vendor list.”

COMBINED UNIT PRICE AND LUMP SUM WORK

The Bidder further proposes to accept as full payment for the Work proposed herein the amounts computed under the provisions of the Contract Documents. For unit price bid items, the estimate of quantities of work to be done is tabulated in the Proposal and, although stated to be done with as much accuracy as possible, is approximate only and is assumed solely for the basis of calculation upon which the award of Contract shall be made. For lump sum bid items, it is expressly understood that the amounts are independent of the exact quantities involved. The Bidder agrees that the amounts for both unit price and lump sum work represent a true measure of labor and materials required to perform the Work, including all allowances for inspection, testing, overhead and profit for each type of work called for in these Contract Documents. The amounts shall be shown in both words and figures. In case of discrepancy, the amount shown in words shall govern.

SPALLING AND STUCCO REPAIR

All quantities for masonry are estimated. As each phase or section of work begins, the Contractor shall mark and measure areas to be repaired. Actual quantities of such work shall be paid at the prescribed unit prices.

Bidder will complete the Work in accordance with the Contract Documents for a fixed fee price.

Truman Annex Itemized Unit Prices

Item	Description	Quantity	Unit	Rate	Cost
1	RAPID Gate costs	1	LS	5,299.00	5,299.00
2	Concrete spall repairs on columns	15	CF	1500.00	22,500.00
3	Stucco Repairs	500	SF	11.00	5,500.00
4	Paint Columns & Curbs 2 Coats (Per LF of fencing)	5972	LF	15.75	94,059.00
5	Demolition and removal of short caps: Sheet C-3	40	EA	83.50	3,340.00
6	Formed and Poured Square Concrete Caps Sheet C-3	40	EA	316.50	12,660.00
7	Demolition and removal of half-height CBS wall	526	LF	44.00	23,144.00
8	Formed and Poured 8" peaked curb: Sheet C-5 (Detail 10.1)	526	LF	49.00	25,774.00
9	Provide and Install 8'H 3-rail security fence	5972	LF	107.00	639,004.00
10	Remove and dispose of 8'H imitation iron fence (1500 LF to be turned over to City)	5972	LF	8.00	47,776.00
11	Provide and install access gates,	10	LF	315.00	3,150.00
12	Provide and install 316SS custom fabricated "fans"	3	EA	2,000.00	6,000.00
13	Concrete Curb repair Sheet C-6	140	CF	150.00	21,000.00
14	Concrete Caps Section 5a (Sheet C-5 Detail 4.1 and 4.2)	13	EA	340.00	4,420.00
Subtotal ~ Truman Annex					913,626.00
<p>Unless stipulated otherwise, all unit prices are to include procurement, delivery, and installation of materials, required equipment, tools, and safety gear, demolition, removal and disposal of waste, clean-up and restoration of facilities and grounds to original or better condition. Painting and masonry repair unit costs to include all materials and labor costs for cleaning, surface preparation, and finishing. All material quantities are estimated. Payouts will be on actual, installed quantities.</p>					

**Trumbo Point Itemized Unit Prices**

Item	Description	Quantity	Unit	Rate	Cost
15	Extend height of existing concrete 16" sq. pilasters from 72" nom. to 96" min. Sheet C-4	49	EA	475.00	23,275.00
16	Stucco refinishing extended pilasters (and prep/prime for paint)	2090	SF	6.80	14,212.00
17	Paint pilasters & caps (two coats)	1166	LF	16.00	18,656.00
18	Provide and install 8'H 3-rail security fence	1166	LF	107.00	124,762.00
19	Demolition and removal of existing precast caps	49	EA	83.00	4,067.00
20	Remove and dispose of 6'H imitation iron fence	1166	LF	7.00	8,162.00
21	Formed and Poured Square Concrete Caps	49	EA	316.00	15,484.00
Subtotal ~ Trumbo Point				208,618.00	
<small>Unless stipulated otherwise, all unit prices are to include procurement, delivery, and installation of materials, required equipment, tools, and safety gear; demolition, removal and disposal of waste, clean-up and restoration of facilities and grounds to original or better condition. Painting and masonry repair unit costs to include all materials and labor costs for cleaning, surface preparation, and finishing. All material quantities are estimated. Payouts will be on actual, installed quantities.</small>					

EXTENDED LUMP SUM BASE BID - TOTAL OF ALL EXTENDED UNIT PRICES: \$1,122,244.00

One Million One Hundred Twenty Two Thousand Two Hundred Forty Four Dollars

(Amount written in words has precedence)

and no Cents

TOTAL LUMP SUM BASE BID

\$ 1,122,244.00  
(numerals)

JULY 16, 2012

BID FORM  
00 41 13 - 5



ALTERNATE BID ITEMS

Item	Description	Quantity	Unit	Rate	Cost
Alternate Bid Item #1					
1a	Section 9 Provide and install 8'H fence	596	LF	107.00	63,772.00
1b	Section 9 Paint Columns & Curbs 2 Coats (Per LF of fencing)	596	LF	15.75	9,387.00
1c	Section 9 Remove and dispose of 8'H imitation iron fence	596	LF	8.00	4,768.00
1d	Section 9 Provide and install gates, removing existing gates.	14	LF	315.00	4,410.00
Subtotal - Alternate Bid Item #1					\$ 82,337.00
Alt. Bid Item #2	Section 1 – Additional cost to substitute Aluminum 8'H fence for Galvanized fence	350	LF	57.00	19,950.00
Alt. Bid Item #3	Section 2 – Additional cost to substitute Aluminum 8'H fence for Galvanized fence	752	LF	57.00	42,864.00
Alt. Bid Item #4	Section 5A – Additional cost to substitute Aluminum 8'H fence for Galvanized fence	135	LF	57.00	7,695.00
Alt. Bid Item #5	Section 13 – Additional cost to substitute Aluminum 8'H fence for Galvanized fence	72	LF	57.00	4,104.00
Alt. Bid Item #6	Section 1 – Additional cost to substitute 316SS 8'H fence for Galvanized fence <sup>2</sup>	350	LF	325.00	113,750.00
Alt. Bid Item #7	Section 2 – Additional cost to substitute 316SS 8'H fence for Galvanized fence <sup>2</sup>	752	LF	325.00	244,400.00
Alt. Bid Item #8	Section 5A – Additional cost to substitute 316SS 8'H fence for Galvanized fence <sup>2</sup>	135	LF	325.00	43,875.00
Alt. Bid Item #9	Section 13 – Additional cost to substitute 316SS 8'H fence for Galvanized fence <sup>2</sup>	72	LF	325.00	23,400.00

Alternate Bid Items Notes:

- Section numbers refer to fencing sections as depicted on Sheet 00 82 02 in Section 3 - Drawings and Specifications.
- Alternate bid items # 6 through #9 inclusive are for substitution of 316 Stainless Steel fencing sections which may not be commercially available. If bidder enters n/a for any or all of these four Alternate Bid Items and submits in writing the reason(s) for not submitting a cost for these items, such bids shall still be considered responsive and shall not be disqualified. If such a bidder shall prevail and be awarded this contract, the City may at its discretion deduct the four affected sections from the base contract without affecting the unit prices as applied to all other sections.
- Alternate bid items #2 though #9 shall have a black power coated finish. Cost of this finish shall be included in the unit prices
- All material quantities are estimated. Payouts will be on actual, installed quantities.

BID FORM  
00 41 13 - 6

JULY 16, 2012

5. SUBCONTRACTORS

The Bidder further proposes that the following subcontracting firms or businesses will be awarded subcontracts for the following portions of the Work in the event that the Bidder is awarded the Contract:

Florida Fence Corp  
Name

P.O. Box 227 Tavernier FL 33070  
Street City State Zip

Bella Construction of Key West, Inc.  
Name

111 US Highway 1 # 110 Key West FL 33070  
Street City State Zip

Name

Street City State Zip

Name

Street City State Zip

Surety

Hartford Accident + Indemnity Co. whose address is

P.O. Box 3001 Troy MI 48007  
Street City State Zip

**Bidder**

The name of the Bidder submitting this Bid is Douglas N. Higgins, Inc

\_\_\_\_\_ doing business at

3390 Pointe Rd. Suite A      Ann Arbor      MI 48108  
Street                                      City                                      State                                      Zip

which is the address to which all communications concerned with this Bid and with the Contract shall be sent.

The names of the principal officers of the corporation submitting this Bid, or of the partnership, or of all persons interested in this Bid as principals are/as follows:

Douglas N. Higgins - President      R. Suzanne Hawker - Secretary-Treasurer  
Daniel Higgins, William D. Higgins, James H Sweet & Kelly Wilkie - Vice President

**If Sole Proprietor or Partnership**

IN WITNESS hereto the undersigned has set his (its) hand this 17 day of July 2012

\_\_\_\_\_  
Signature of Bidder

\_\_\_\_\_  
Title

If Corporation

IN WITNESS WHEREOF the undersigned corporation has caused this instrument to be executed and its seal affixed by its duly authorized officers this 18 day of July 2012.

(SEAL)

Douglas M. Higgins, Inc.  
Name of Corporation

By: Kelley A. Wilkie

Title: Vice-President

Attest: L. Suzanne Hawke  
Secretary

END OF SECTION

July 16, 2012  
~~JUNE 21, 2012~~

BID FORM  
00 41 13 - 9

Att #2

ANTI-KICKBACK AFFIDAVIT

STATE OF ~~FLORIDA~~ <sup>Michigan</sup> )  
COUNTY OF ~~MONROE~~ <sup>Washtenaw</sup> : SS )

I, the undersigned hereby duly sworn, depose and say that no portion of the sum herein bid will be paid to any employees of the City of Key West as a commission, kickback, reward or gift, directly or indirectly by me or any member of my firm or by an officer of the corporation.

By: Kellya Wilkie  
Vice-President

Sworn and subscribed before me this  
18th day of July, 2012

R. Suzanne Hawker  
NOTARY PUBLIC, State of Florida Michigan  
at Large

R. SUZANNE HAWKER  
Notary Public, Washtenaw County, MI  
My Commission Expires Mar 7, 2017

My Commission Expires: \_\_\_\_\_

END OF SECTION

SWORN STATEMENT UNDER SECTION 287.133(3)(A)  
FLORIDA STATUTES, ON PUBLIC ENTITY CRIMES

THIS FORM MUST BE SIGNED IN THE PRESENCE OF A NOTARY PUBLIC OR OTHER OFFICER  
AUTHORIZED TO ADMINISTER OATHS.

1. This sworn statement is submitted with Bid or Proposal for ITB #12-029

2. This sworn statement is submitted by Douglas N. Higgins, Inc  
(name of entity submitting sworn statement)

whose business address is 3390 Travis Pointe Rd. Suite A

Ann Arbor, MI 48108 and (if applicable) its Federal Employer

Identification Number (FEIN) is 38-1807765

(If the entity has no FEIN, include the Social Security Number of the individual signing this  
sworn statement NA)

3. My name is Kelly A. Wilkie  
(please print name of individual signing)

and my relationship to the entity named above is Vice-President

4. I understand that a "public entity crime" as defined in Paragraph 287.133(1)(g), Florida Statutes, means a violation of any state or federal law by a person with respect to and directly related to the transaction of business with any public entity or with an agency or political subdivision of any other state or with the United States, including but not limited to, any bid or contract for goods or services to be provided to any public or an agency or political subdivision of any other state or of the United States and involving antitrust, fraud, theft, bribery, collusion, racketeering, conspiracy, material misrepresentation.

5. I understand that "convicted" or "conviction" as defined in Paragraph 287.133(1)(b), Florida Statutes, means a finding of guilt or a conviction of a public entity crime, with or without an adjudication of guilt, in any federal or state trial court of record relating to charges brought by indictment information after July 1, 1989, as a result of a jury verdict, nonjury trial, or entry of a plea of guilty or nolo contendere.

6. I understand that an "affiliate" as defined in Paragraph 287.133(1)(a), Florida Statutes, means

1. A predecessor or successor of a person convicted of a public entity crime; or
2. An entity under the control of any natural person who is active in the management of the entity and who has been convicted of a public entity crime. The term "affiliate" includes those officers, directors, executives, partners, shareholders, employees, members, and agents who are active in the management of an affiliate. The ownership by one person of shares constituting controlling interest in another person, or a pooling of equipment or income among persons when not for fair market value under an arm's length agreement, shall be a prima facie case that one person controls another person. A person who knowingly enters into a joint venture with a person who has been convicted of a public entity crime in Florida during the preceding 36 months shall be considered an affiliate.

7. I understand that a "person" as defined in Paragraph 287.133(1)(8), Florida Statutes, means any natural person or entity organized under the laws of any state or of the United States with the legal power to enter into a binding contract and which bids or applies to bid on contracts for the provision of goods or services let by a public entity, or which otherwise transacts or applies to transact business with public entity. The term "person" includes those officers, directors, executives, partners, shareholders, employees, members, and agents who are active in management of an entity.
8. Based on information and belief, the statement which I have marked below is true in relation to the entity submitting this sworn statement. (Please indicate which statement applies).

Neither the entity submitting this sworn statement, nor any officers, directors, executives, partners, shareholders, employees, members, or agents who are active in management of the entity, nor any affiliate of the entity have been charged with and convicted of a public entity crime subsequent to July 1, 1989, AND (Please indicate which additional statement applies.)

There has been a proceeding concerning the conviction before a hearing of the State of Florida, Division of Administrative Hearings. The final order entered by the hearing officer did not place the person or affiliate on the convicted vendor list. (Please attach a copy of the final order.)

The person or affiliate was placed on the convicted vendor list. There has been a subsequent proceeding before a hearing officer of the State of Florida, Division of Administrative Hearings. The final order entered by the hearing officer determined that it was in the public interest to remove the person or affiliate from the convicted vendor list. (Please attach a copy of the final order.)

The person or affiliate has not been put on the convicted vendor list. (Please describe any action taken by or pending with the Department of General Services.)

Kelley A. Wilkie  
(signature)  
7/18/2012  
(date)

STATE OF Michigan  
COUNTY OF Washtenaw

PERSONALLY APPEARED BEFORE ME, the undersigned authority,

Kelley A. Wilkie who, after first being sworn by me, affixed his/her  
(name of individual signing)

signature in the space provided above on this 18th of July, 2012.

My commission expires:

**R. SUZANNE HAWKER**  
Notary Public, Washtenaw County, MI  
My Commission Expires Mar 7, 2017

R. Suzanne Hawker  
NOTARY PUBLIC

**CITY OF KEY WEST INDEMNIFICATION FORM**

Contractor agrees to protect, defend, indemnify, save and hold harmless The City of Key West, all its Departments, Agencies, Boards, Commissions, officers, agents, servants and employees, including volunteers, from and against any and all claims, debts, demands, expense and liability arising out of injury or death to any person or the damage, loss of destruction of any property which may occur or in any way grow out of any act or omission of the Contractor, its agents, servants, and employees, or any and all costs, expense and/or attorney fees incurred by the City as a result of any claim, demands, and/or causes of action except of those claims, demands, and/or causes of action arising out of the negligence of The City of Key West, all its Departments, Agencies, Boards, Commissions, officers, agents, servants and employees. The Contractor agrees to investigate, handle, respond to, provide defense for and defend any such claims, demand, or suit at its sole expense and agrees to bear all other costs and expenses related thereto, even if it (claims, etc.) is groundless, false or fraudulent. The City of Key West does not waive any of its sovereign immunity rights, including but not limited to, those expressed in Section 768.28, Florida Statutes.

These indemnifications shall survive the term of this agreement. In the event that any action or proceeding is brought against the City of Key West by reason of such claim or demand, Contractor shall, upon written notice from the City of Key West, resist and defend such action or proceeding by counsel satisfactory to the City of Key West.

The indemnification provided above shall obligate Contractor to defend at its own expense to and through appellate, supplemental or bankruptcy proceeding, or to provide for such defense, at the City of Key West's option, any and all claims of liability and all suits and actions of every name and description covered above which may be brought against the City of Key West whether performed by Contractor, or persons employed or utilized by Contractor.

The Contractor's obligation under this provision shall not be limited in any way by the agreed upon Contract Price as shown in this agreement, or the Contractor's limit of or lack of sufficient insurance protection.

CONTRACTOR: Douglas N. Higgins, Inc.  
3390 Trans Pointe Rd. Suite A  
Ann Arbor, MI 48108  
Address  
Kelly A. Wilkie  
Signature  
Kelly A. Wilkie  
Print Name  
Vice - President  
Title

SEAL:

DATE: July 18, 2010



LOCAL VENDOR CERTIFICATION PURSUANT TO CKW ORDINANCE 09-22

SECTION 2-798

n/a

The undersigned, as a duly authorized representative of the vendor listed herein, certifies to the best of his/her knowledge and belief, that the vendor meets the definition of a "Local Business." For purposes of this section, "local business" shall mean a business which:

- a. Principle address as registered with the FL Department of State located within 30 miles of the boundaries of the city, listed with the chief licensing official as having a business tax receipt with its principle address within 30 miles of the boundaries of the city for at least one year immediately prior to the issuance of the solicitation.
- b. Maintains a workforce of at least 50 percent of its employees from the city or within 30 miles of its boundaries.
- c. Having paid all current license taxes and any other fees due the city at least 24 hours prior to the publication of the call for bids or request for proposals.
  - Not a local vendor pursuant to Ordinance 09-22 Section 2-798
  - Qualifies as a local vendor pursuant to Ordinance 09-22 Section 2-798

If you qualify, please complete the following in support of the self certification & submit copies of your County and City business licenses. Failure to provide the information requested will result in denial of certification as a local business.

Business Name

Phone:

Current Local Address:  
(P.O Box numbers may not be used to establish status)

Fax:

Length of time at this address

\_\_\_\_\_  
Signature of Authorized Representative

\_\_\_\_\_  
Date

STATE OF \_\_\_\_\_  
COUNTY OF \_\_\_\_\_

The foregoing instrument was acknowledged before me this \_\_\_\_\_ day of \_\_\_\_\_, 20\_\_\_\_.

By \_\_\_\_\_, of \_\_\_\_\_  
(Name of officer or agent, title of officer or agent) Name of corporation acknowledging)  
or has produced \_\_\_\_\_ as identification  
(type of identification)

\_\_\_\_\_  
Signature of Notary

Return Completed form with  
Supporting documents to:  
City of Key West Purchasing

\_\_\_\_\_  
Print, Type or Stamp Name of Notary

\_\_\_\_\_  
Title or Rank

DISCLOSURE OF LOBBYING ACTIVITIES

N/A

Complete this form to disclose lobbying activities pursuant to 31 U.S.C. 1352  
(See reverse for public burden disclosure.)

<p><b>1. Type of Federal Action:</b></p> <input type="checkbox"/> a. contract b. grant c. cooperative agreement d. loan e. loan guarantee f. loan insurance	<p><b>2. Status of Federal Action:</b></p> <input type="checkbox"/> a. bid/offer/application b. initial award c. post-award	<p><b>3. Report Type:</b></p> <input type="checkbox"/> a. initial filing b. material change
<p><b>4. Name and Address of Reporting Entity:</b></p> <input type="checkbox"/> Prime <input type="checkbox"/> Subawardee Tier _____, if known:  Congressional District, if known:		<p><b>5. If Reporting Entity in No. 4 is Subawardee, Enter Name and Address of Prime:</b></p>          Congressional District, if known:
<p><b>6. Federal Department/Agency:</b></p>	<p><b>7. Federal Program Name/Description:</b></p>  CFDA Number, if applicable: _____	
<p><b>8. Federal Action Number, if known:</b></p>	<p><b>9. Award Amount, if known:</b></p> \$	

<p><b>10. a. Name and Address of Lobbying Entity</b> <i>(if individual, last name, first name, MI):</i></p> <p style="text-align: right;"><i>(attach Continuation Sheet(s))</i></p>	<p><b>b. Individuals Performing Services</b> <i>(including address if different from No. 10a)</i> <i>(last name, first name, MI):</i></p> <p style="text-align: right;"><i>SF-LLLA, if necessary)</i></p>
<p><b>11. Information requested through this form is authorized by title 31 U.S.C. section 1352. This disclosure of lobbying activities is a material representation of fact upon which reliance was placed by the tier above when this transaction was made or entered into. This disclosure is required pursuant to 31 U.S.C. 1352. This information will be reported to Congress semi-annually and will be available for public inspection. Any person who fails to file the required disclosure shall be subject to a civil penalty of not less than \$10,000 and not more than \$100,000 for each such failure.</b></p>	<p><b>Signature:</b> _____</p> <p><b>Print Name:</b> _____</p> <p><b>Title:</b> _____</p> <p><b>Telephone No.:</b> _____ <b>Date:</b> _____</p>
<p><b>Federal Use Only:</b></p>	<p>Authorized for Local Reproduction Standard Form - LLL (Rev 7 - 97)</p>

FORM DEP 55-221 (01/01)

## **INSTRUCTIONS FOR COMPLETION OF SF-LLL, DISCLOSURE OF LOBBYING ACTIVITIES**

This disclosure form shall be completed by the reporting entity, whether subawardee or prime Federal recipient, at the initiation or receipt of a covered Federal action, or a material change to a previous filing, pursuant to title 31 U.S.C. section 1352. The filing of a form is required for each payment or agreement to make payment to any lobbying entity for influencing or attempting to influence an officer or employee of any agency, a Member of Congress, an officer or employee of Congress, or an employee of a Member of Congress in connection with a covered Federal action. Complete all items that apply for both the initial filing and material change report. Refer to the implementing guidance published by the Office of Management and Budget for additional information.

1. Identify the type of covered Federal action for which lobbying activity is and/or has been secured to influence the outcome of a covered Federal action.
2. Identify the status of the covered Federal action.
3. Identify the appropriate classification of this report. If this is a follow up report caused by a material change to the information previously reported, enter the year and quarter in which the change occurred. Enter the date of the last previously submitted report by the reporting entity for this covered Federal action.
4. Enter the full name, address, city, state and zip code of the reporting entity. Include Congressional District, if known. Check the appropriate classification of the reporting entity that designates if it is or expects to be, a prime or subaward recipient. Identify the tier of the subawardee, e.g., the first subawardee of the prime is the 1st tier. Subawards include but are not limited to subcontracts, subgrants and contract awards under grants.
5. If the organization filing the report in item 4 checks "Subawardee", then enter the full name, address, city, state and zip code of the prime Federal recipient. Include Congressional District, if known.
6. Enter the name of the Federal agency making the award or loan commitment. Include at least one organizational level below agency name, if known. For example, Department of Transportation, United States Coast Guard.
7. Enter the Federal program name or description for the covered Federal action (item 1). If known, enter the full Catalog of Federal Domestic Assistance (CFDA) number for grants, cooperative agreements, loans, and loan commitments.

8. Enter the most appropriate Federal identifying number available for the Federal action identified in item 1 (e.g., Request for Proposal (RFP) number; Invitation for Bid (IFB) number; grant announcement number; the contract, grant, or loan award number; the application/proposal control number assigned by the Federal agency). Include prefixes, e.g., "RFP-DE-90-001."
9. For a covered Federal action where there has been an award or loan commitment by the Federal agency, enter the Federal amount of the award/loan commitment for the prime entity identified in item 4 or 5.
10. (a) Enter the full name, address, city, state and zip code of the lobbying entity engaged by the reporting entity identified in item 4 to influence the covered Federal action.  
  
(b) Enter the full names of the individual(s) performing services, and include full address if different from 10 (a). Enter Last Name, First Name, and Middle Initial (MI).
11. The certifying official shall sign and date the form, print his/her name, title and telephone number.

According to the Paperwork Reduction Act, as amended, no persons are required to respond to a collection of information unless it displays a valid OMB Control Number. The valid OMB control number for this information collection is OMB No. 0348-0046. Public reporting burden for this collection of information is estimated to average 30 minutes per response, including time for reviewing instructions, searching existing data sources, gathering and maintaining the data needed, and completing and reviewing the collection of information. Send comments regarding the burden estimate or any other aspect of this collection of information, including suggestions for reducing this burden, to the Office of Management and Budget, Paperwork Reduction Project (0348-0046), Washington, D.C. 20503.

Form DEP 55-221 (01/01)

NON-COLLUSION DECLARATION AND  
COMPLIANCE WITH 49 CFR §29.

ITEM/SEGMENT NO.: ITB#12-029  
F.A.P. NO.:  
PARCEL NO.:  
COUNTY OF:  
BID LETTING OF: July 18, 2012

I, Kelly A. Wikie, hereby  
declare that I am Vice-President of Douglas N. Higgins, Inc.  
Of Ann Arbor, Michigan

and that I am the person responsible within my firm for the final decision as to the price(s) and amount of this Bid on this Project.

I further declare that:

1. The prices(s) and amount of this bid have been arrived at independently, without consultation, communication or agreement, for the purpose of restricting competition with any other contractor, bidder or potential bidder.

2. Neither the price(s) nor the amount of this bid have been disclosed to any other firm or person who is a bidder or potential bidder on this project, and will not be so disclosed prior to the bid opening.

3. No attempt has been made or will be made to solicit, cause or induce any other firm or person to refrain from bidding on this project, or to submit a bid higher than the bid of this firm, or any intentionally high or non-competitive bid or other form of complementary bid.

4. The bid of my firm is made in good faith and not pursuant to any agreement or discussion with, or inducement from, any firm or person to submit a complementary bid.

5. My firm has not offered or entered into a subcontract or agreement regarding the purchase of materials or services from any firm or person, or offered, promised or paid cash or anything of value to any firm or person, whether in connection with this or any other project, in consideration for an agreement or promise by any firm or person to refrain from bidding or to submit a complementary bid on this project.

6. My firm has not accepted or been promised any subcontract or agreement regarding the sale of materials or services to any firm or person, and has not been promised or paid cash or anything of value by any firm or person, whether in connection with this or any other project, in consideration for my firm's submitting a complementary bid, or agreeing to do so, on this project.

7. I have made a diligent inquiry of all members, officers, employees, and agents of my firm with responsibilities relating to the preparation, approval or submission of my firm's bid on this project and have been advised by each of them that he or she has not participated in any communication, consultation, discussion, agreement, collusion, act or other conduct inconsistent with any of the statements and representations made in this Declaration.

8. As required by Section 337.165, Florida Statutes, the firm has fully informed the City of Key West in writing of all convictions of the firm, its affiliates (as defined in Section 337.165(1)(a),

MAY 24, 2012

NON-COLLUSION DECLARATION  
AND COMPLIANCE WITH 49 CFR §29  
00 44 02 - 1

Florida Statutes), and all directors, officers, and employees of the firm and its affiliates for violation of state or federal antitrust laws with respect to a public contract or for violation of any state or federal law involving fraud, bribery, collusion, conspiracy or material misrepresentation with respect to a public contract. This includes disclosure of the names of current employees of the firm or affiliates who were convicted of contract crimes while in the employ of another company.

9. I certify that, except as noted below, neither my firm nor any person associated therewith in the capacity of owner, partner, director, officer, principal, investigator, project director, manager, auditor, and/or position involving the administration of Federal funds:

(a) is presently debarred, suspended, proposed for debarment, declared ineligible, or voluntarily excluded from covered transactions, as defined in 49 CFR §29.110(a), by any Federal department or agency;

(b) has within a three-year period preceding this certification been convicted of or had a civil judgment rendered against him or her for: commission of fraud or a criminal offense in connection with obtaining, attempting to obtain, or performing a Federal, State or local government transaction or public contract; violation of Federal or State antitrust statutes; or commission of embezzlement, theft, forgery, bribery, falsification or destruction of records, making false statements or receiving stolen property;

(c) is presently indicted for or otherwise criminally or civilly charged by a Federal, State or local governmental entity with commission of any of the offenses enumerated in paragraph 9(b) of this certification; and

(d) has within a three-year period preceding this certification had one or more Federal, State or local government public transactions terminated for cause or default.

10. I(We), certify that I(We), shall not knowingly enter into any transaction with any subcontractor, material supplier, or vendor who is debarred, suspended, declared ineligible, or voluntarily excluded from participation in this contract by any Federal Agency unless authorized by the Department.

Where I am unable to declare or certify as to any of the statements contained in the above stated paragraphs numbered (1) through (10), I have provided an explanation in the "Exceptions" portion below or by attached separate sheet.

EXCEPTIONS:

(Any exception listed above will not necessarily result in denial of award, but will be considered in determining bidder responsibility. For any exception noted, indicate to whom it applies, initiating agency and dates of agency action.

Providing false information may result in criminal prosecution and/or administrative sanctions.)

I declare under penalty of perjury that the foregoing is true and correct.

CONTRACTOR: Douglas N. Higgins, Inc

BY: Kelly A. Wilkie Vice-President  
NAME AND TITLE PRINTED

WITNESS: Judith Wilkie

BY: Kelly A. Wilkie  
SIGNATURE

WITNESS: R. Suzanne Hawker

Executed on this 18<sup>th</sup> day of July, 2012

**FAILURE TO FULLY COMPLETE AND EXECUTE THIS DOCUMENT  
MAY RESULT IN THE BID BEING DECLARED NONRESPONSIVE**



## SUSPENSION AND DEBARMENT CERTIFICATION

### CERTIFICATION REGARDING DEBARMENTS, SUSPENSION, INELIGIBILITY AND VOLUNTARY EXCLUSION-LOWER TIER FEDERALLY FUNDED TRANSACTIONS

1. The undersigned hereby certifies that neither it nor its principals is presently debarred, suspended, proposed for debarment, declared ineligible, or voluntarily excluded from participation in this transaction by any Federal department or agency.

2. The undersigned also certifies that it and its principals:

(a) Have not within a three-year period preceding this certification been convicted of or had a civil judgment rendered

against them for commission of fraud or a criminal offense in connection with obtaining, attempting to obtain, or performing a public (Federal, State or local) transaction or contract under a public transaction; violation of Federal or State anti-trust statutes or commission of embezzlement, theft, forgery, bribery, falsification or destruction of records, making false statements, or receiving stolen property.

(b) Are not presently indicted for or otherwise criminally or civilly charged by a governmental entity (Federal, State or local) with commission of any of the offenses enumerated in paragraph 2.(a) of this Certification; and

(c) Have not within a three-year period preceding this certification had one or more public transactions (Federal, State or local) terminated for cause or default.

3. Where the undersigned is unable to certify to any of the statements in this certification, an explanation shall be attached to this certification.

Dated this day of, 20 July 18, 2012

By Kelly A. Wilkie  
Authorized Signature/Contractor

Kelly A. Wilkie, Vice-President  
Typed Name/Title

Douglas M. Higgins, Inc.  
Contractor's Firm Name

3390 Travis Pointe Rd. Suite A  
Street Address

Ann Arbor, MI 48108  
Building, Suite Number

(734) 996-9500  
City/State/Zip Code

Area Code/Telephone Number

## BIDDER'S CHECKLIST

(Note: The purpose of this checklist is to serve as a reminder of major items to be addressed in submitting a bid and is not intended to be all inclusive. It does not alleviate the Bidder from the responsibility of becoming familiar with all aspects of the Contract Documents and proper completion and submission of his bid.)

1. All Contract Documents thoroughly read and understood. [✓]
2. All blank spaces in Proposal filled in, using black ink. [✓]
3. Total and unit prices added correctly. [✓]
4. Addenda acknowledged. [✓]
5. Subcontractors are named as indicated in the Proposal. [✓]
6. Experience record included. [✓]
7. Bid signed by authorized officer. [✓]
8. Bid Bond completed and executed, including power-of-attorney dated the same date as Bid Bond. [✓]
9. Bidder familiar with federal, state, and local laws, ordinances, rules and regulations affecting performance of the work. [✓]
10. Bidder, if successful, able to obtain and/or demonstrate possession of required licenses and certificates within (10) ten calendar days after receiving a Notice of Award. [✓]
11. Bid submitted intact with the volume containing the Bidding Requirements, Contract Forms, and Conditions of the Contract and three (3) copies. [✓]
12. Bid Documents submitted in sealed envelope and addressed and labeled in conformance with the instructions in the Invitation to Bid. [✓]
13. Bidder must provide satisfactory documentation of State Licenses [✓]
14. / Anti-Kickback Affidavit. [✓]
15. / Public Entity Crimes. [✓]
16. / Local Vendor Certification. [N/A]
17. / Disclosure of Lobbying Activities. [✓]
18. / Non-Collusion Declaration and Compliance. [✓]
19. / Suspension and Debarment Certification. [✓]
20. Catalog Cuts of all Proposed Materials and Products [✓]

DOUGLAS N. HIGGINS, INC.  
EXPERIENCE - PAST EIGHT YEARS - GROUP 1

<p><b>Project Name:</b> City County Flow Swap</p> <p><b>Owner - Address - Project Manager - Phone:</b> Collier County Public Utilities Engineering 3301 East Tamiami Trail, Building H Naples, Florida 34112 Sandy Sridhar</p> <p><b>Engineer - Address - Phone:</b> Agnoli, Barber and Brundage 7400 Trail Blvd. Naples, Florida 34102 Dominic Amico</p> <p><b>Contract Date:</b> <b>Final Contract Amount:</b> <b>Completion Date:</b> <b>Project Description:</b> Installation of force main, MDV's and valve vaults to two locations which would allow bypass from Collier County to the City of Naples.</p>	<p><b>Project Name:</b> Collier County Justice Center</p> <p><b>Owner - Address - Project Manager - Phone:</b> Collier County Facilities Management Department 3301 East Tamiami Trail Naples, Florida 34112 John Clements</p> <p><b>Engineer - Address - Phone:</b> Q. Grady Minor and Associates, P.A. 3800 Via Del Rey Bonita Springs, Florida 34134 David Schmitt 239-947-1144</p> <p><b>Contract Date:</b> \$81,950.00 <b>Final Contract Amount:</b> \$141,568.41 <b>Completion Date:</b> August, 2009 <b>Project Description:</b> Construction of grinder pump station (vault), installation of muffin monster (grinder/auger assembly), new sanitary sewer and manholes. Replacement of the existing sanitary sewer with a new 12-inch main and a high water alarm system.</p>
<p><b>Project Name:</b> Pump Station S-6 Gearbox Replacement</p> <p><b>Owner - Address - Project Manager - Phone:</b> South Florida Water Management District 2101 Centrepark West Drive, Suite 110 West Palm Beach, Florida 33409 Gerard Flynn</p> <p><b>Engineer - Address - Phone:</b> South Florida Water Management District 3301 Gun Club Road West Palm Beach, Florida 33406 Michael Millares</p> <p><b>Contract Date:</b> December 3, 2009 <b>Final Contract Amount:</b> \$2,191,945.00 <b>Completion Date:</b> May 2010 <b>Project Description:</b> Replacement of three massive gearboxes for three 84" Gas Engine driven Vertical Turbine Pumps.</p>	<p><b>Project Name:</b> Cove Stormwater Pump Station Imp.</p> <p><b>Owner - Address - Project Manager - Phone:</b> City of Naples Department of Streets and Stormwater 295 Riverside Circle Naples, Florida 34102 (239) 213-5000</p> <p><b>Engineer - Address - Phone:</b> AECOM 4415 Metro Parkway Suite 404 Fort Myers, Florida 33916 (239) 278-7998</p> <p><b>Contract Date:</b> 2/4/09 Award, 3/16/09 NTP <b>Final Contract Amount:</b> \$2,778,000.00 <b>Completion Date:</b> 2/8/10 (Contract) <b>Project Description:</b> Replacement of large Vertical Turbine Pumps. Installation of a large, below grade and water table, cast in place structure which included gates, an 60" bypass pipe, a trash rack. Project also included significant Electrical &amp; Instrumentation</p>
<p><b>Project Name:</b> Master Pump Station 305 Rehabilitation</p> <p><b>Owner - Address - Project Manager - Phone:</b> Collier County Public Utilities Engineering Department 3301 Tamiami Trail East, Building H Naples, Florida 34112 Sandy Sridhar</p> <p><b>Engineer - Address:</b> Q. Grady Minor and Associates, P.A. 3800 Via Del Rey Bonita Springs, Florida 34134 David Schmitt</p> <p><b>Contract Date:</b> August 11, 2008 <b>Final Contract Amount:</b> \$444,000.00 <b>Completion Date:</b> January 16, 2009 <b>Project Description:</b> Fully rehab 2300 GPM Master Pump Station</p>	<p><b>Project Name:</b> Water Reuse Piping Modifications / Reuse System Upgrade</p> <p><b>Owner - Address - Project Manager - Phone:</b> City of Marco Island Public Utilities 50 Bald Eagle Drive Marco Island, Florida 34145 Bruce Weinstein 239-389-5000</p> <p><b>Engineer:</b> Metzall and Eddy</p> <p><b>Contract Date:</b> February 10, 2008 <b>Final Contract Amount:</b> \$649,171.57 <b>Completion Date:</b> November 2008 <b>Project Description:</b> Rehab 500,000 Gallon Tank and convert potable water facility to reuse storage facility</p>

**DOUGLAS N. HIGGINS, INC.**  
**EXPERIENCE - PAST EIGHT YEARS - GROUP 1**

<p><b>Project Name:</b> CAT Operations &amp; Administration Center Pump Station and Force Main Connection</p> <p><b>Owner - Address - Project Manager - Phone:</b>          Collier County          Alternative Transportation Division          2885 South Horseshoe Drive          Naples, Florida 34104          Sue Faulkner</p> <p><b>Engineer:</b>          Q. Grady Minor          3800 Via Del Rey          Bonita Springs, Florida 34134</p> <p><b>Contract Date:</b> February 14, 2008  <b>Final Contract Amount:</b> \$183,673.04  <b>Completion Date:</b> May 1, 2008</p> <p><b>Project Description:</b>          Installation of 14-inch force main, pump station and valve vault to existing CAT Operations Building.</p>	<p><b>Project Name:</b> San Marco Master Lift Station</p> <p><b>Owner - Address - Project Manager - Phone:</b>          City of Marco Island          Public Works          50 Bald Eagle Drive          Marco Island, Florida 34145          Timothy E. Pinter, P.E.</p> <p><b>Engineer - Address - Phone:</b></p> <p><b>Contract Date:</b> January 2, 2008  <b>Final Contract Amount:</b> \$83,615.61  <b>Completion Date:</b></p> <p><b>Project Description:</b>          Construct new 600 GPM Master Lift Station</p>
<p><b>Project Name:</b> Irrigation Quality Water Project</p> <p><b>Owner - Address - Project Manager - Phone:</b>          Collier County          Facilities Management          3301 Tamiami Trail East, Building W          Naples, Florida 34112          Damon Gonzales</p> <p><b>Engineer - Address - Phone:</b>          Anchor Engineering</p> <p><b>Contract Date:</b> March 14, 2007  <b>Final Contract Amount:</b> \$1,213,474.52  <b>Completion Date:</b> January 15, 2008</p> <p><b>Project Description:</b>          Irrigation improvements at Collier County Government Complex. Work was coordinated with an operating complex and interruptions were minimized or eliminated.</p>	<p><b>Project Name:</b> Golden Gate WWTP and Injection Pump Station</p> <p><b>Owner - Address - Project Manager - Phone:</b>          Florida Governmental Utility Authority          280 Wekiva Springs Road, Suite 203          Longwood, Florida 32779</p> <p><b>Engineer - Address - Phone:</b>          Arcadis          4307 Vineland Road          Suite H-20          Orlando, Florida 32811          407-236-5700</p> <p><b>Contract Date:</b>  <b>Final Contract Amount:</b>  <b>Completion Date:</b></p> <p><b>Project Description:</b>          Expansion of Golden Gate WWTP which included the construction of a new digester, chlorine contact tank and injection well pump station, modification of clarifiers #1 and #2, installation of surge and annular pressure tanks and appurtenances.</p>
<p><b>Project Name:</b> Trestline Master Pump Station</p> <p><b>Owner - Address - Project Manager - Phone:</b>          City of Fort Myers          2200 Second Street          Fort Myers, Florida 33902          Eilana Hayes, E.I.          (239) 332-6318</p> <p><b>Engineer - Address - Phone:</b>          Johnson Engineering, Inc.          2122 Johnson Street          Fort Myers, Florida 33920          David Troutaud          (239) 334-0048</p> <p><b>Contract Date:</b> July 1, 2008  <b>Final Contract Amount:</b> \$1,043,805.00 - Not Final  <b>Completion Date:</b> February, 2009</p> <p><b>Project Description:</b>          Installation of a master pump station located along Trestline Avenue. The project entailed a jack and bore under Trestline Avenue to connect to the existing force main and construction of a 20 foot deep master pump station. A 400 KW generator and odor control unit were also installed.</p>	<p><b>Project Name:</b> PS S-127 and S-133 Pump Refurbishment and Bearing Replace.</p> <p><b>Owner - Address - Project Manager - Phone:</b>          South Florida Water Management District          2101 Centrepark West Drive, Suite 110          West Palm Beach, Florida 33409          Mike Curley</p> <p><b>Engineer - Address - Phone:</b>          South Florida Water Management District          3301 Gun Club Road          West Palm Beach, Florida 33408          Teri Swartz</p> <p><b>Contract Date:</b> April 10, 2008  <b>Final Contract Amount:</b> \$3,947,723.00  <b>Completion Date:</b> July 2010</p> <p><b>Project Description:</b>          Completely recondition the main 42" vertical turbine pumps, five at S-127 and five at S-133. Install new electrical and instrumentation.</p>

DOUGLAS N. HIGGINS, INC.  
EXPERIENCE - PAST EIGHT YEARS - GROUP 1

<p><b>Project Name:</b> Gateway Triangle Stormwater Improvements</p> <p><b>Owner - Address - Project Manager - Phone:</b> Collier County Stormwater Department 2885 Horseshoe Drive Naples, Florida 34 239-252-8192 Shane Cox</p> <p><b>Engineer - Address:</b> HDR, Inc. 200 West Forsyth Street Jacksonville, Florida 32202 Laura Phillips</p> <p><b>Contract Date:</b> November 5, 2007 <b>Final Contract Amount:</b> \$1,021,936.78 <b>Completion Date:</b> July 28, 2008</p> <p><b>Project Description:</b> Stormwater improvements to existing area - excavation of approximately 34,000 Cy of dirt and grading to form three continuous ponds. Installation of box culverts, sheet piling, concrete ditch pavement and storm drainage structures.</p>	<p><b>Project Name:</b> Marco Island North Barfield &amp; North Marco Sanitary Sewer District</p> <p><b>Owner - Address - Project Manager - Phone:</b> City of Marco Island 50 Bald Eagle Drive Marco Island, FL 34145 Mr. James Miller 239-389-5011</p> <p><b>Engineer - Address - Phone:</b> Boyle Engineering 4415 Metro Parkway, Suite 104 Fort Myers, FL 33918 Fred Mittl 239-278-7998</p> <p><b>Contract Date:</b> March 1, 2007</p> <p><b>Final Contract Amount:</b> North Marco \$4,644,808.99 North Barfield \$7,270,729.37</p> <p><b>Completion Date:</b> North Marco May 11, 2008 North Barfield March 24, 2008</p> <p><b>Project Description:</b> New wastewater collection system installed to replace existing septic tanks. Work included gravity sewer, forcemain, transmission main, pump stations, road restoration, etc.</p>
<p><b>Project Name:</b> NCWRF MLE Bleach Project Phase 2, Mechanical</p> <p><b>Owner - Address - Project Manager:</b> Collier County Public Utilities Engineering Department 3301 Tamiami Trail, East, Building H Naples, Florida 34112 Dianna Duerf</p> <p><b>Engineer - Address - Phone:</b> Hole Montes 950 Encore Way Naples, Florida 34110 Jerry Taricska 239-254-2000</p> <p><b>Contract Date:</b> September 17, 2007 <b>Final Contract Amount:</b> \$338,412.49 <b>Completion Date:</b> June 17, 2008</p> <p><b>Project Description:</b> Bleach piping modifications to chlorine contact chambers and modification of pump skids to have redundancy in bleach feed system.</p>	<p><b>Project Name:</b> Rehabilitation of Master Pump Station 315</p> <p><b>Owner - Address - Project Manager:</b> Collier County Public Utilities Engineering Department 3301 Tamiami Trail East, Building H Naples, Florida 34112 Sandy Sridhar</p> <p><b>Engineer - Address - Phone:</b> Q. Grady Minor &amp; Associates 3800 Via Del Rey Bonita Springs, Florida 34134 David Schmitt 239-947-1144</p> <p><b>Contract Date:</b> November 18, 2007 <b>Final Contract Amount:</b> \$765,823.34 <b>Completion Date:</b> June 3, 2008</p> <p><b>Project Description:</b> Full rehab 800 GPM Master Pump Station</p>
<p><b>Project Name:</b> Rehabilitation of Master Pump Station 318</p> <p><b>Owner - Address - Project Manager - Phone:</b> Collier County Public Utilities Engineering Department 3301 Tamiami Trail East, Building H Naples, Florida 34112 Sandy Sridhar</p> <p><b>Engineer - Address - Phone:</b> Q. Grady Minor &amp; Associates 3800 Via Del Rey Bonita Springs, Florida 34134 David Schmitt 239-947-1144</p> <p><b>Contract Date:</b> October 9, 2007 <b>Final Contract Amount:</b> \$789,070.59 <b>Completion Date:</b> June 10, 2008</p> <p><b>Project Description:</b> Fully rehab 3000 GPM Master Pump Station</p>	<p><b>Project Name:</b> NCRWTP Chemical Laboratory Ventilation Improvements</p> <p><b>Owner - Address - Project Manager - Phone:</b> Collier County Public Utilities Engineering Department 3301 Tamiami Trail East, Building H Naples, Florida 34112 Tom Chmelik 239-732-2575</p> <p><b>Engineer - Address - Phone:</b> TLC Engineering 1400 Colonial Boulevard, Suite 208 Fort Myers, Florida 33907 Nicholas L. Mancuso 239-275-4240</p> <p><b>Contract Date:</b> March 13, 2007 <b>Final Contract Amount:</b> \$749,367.67 <b>Completion Date:</b> November 30, 2008</p> <p><b>Project Description:</b> Replace complete HVAC system including air handler, ductwork, exhaust fans, condensers and rehab fume hoods</p>

DOUGLAS N. HIGGINS, INC.  
EXPERIENCE - PAST EIGHT YEARS - GROUP 1

<p><b>Project Name:</b> Connection to Water Main - Marco Shores</p> <p><b>Owner - Address - Project Manager:</b> City of Marco Island Public Works 60 Bald Eagle Drive Marco Island, Florida 34145 James Miller</p> <p><b>Engineer - Address - Phone:</b></p> <p><b>Contract Date:</b> April 26, 2007 <b>Final Contract Amount:</b> \$188,000.00 <b>Completion Date:</b> August 31, 2007 <b>Project Description:</b> Watermain connection at Marco Shores.</p>	<p><b>Project Name:</b> Collier County NCRWTP AND SCRWTP Sand Separators</p> <p><b>Owner - Address - Project Manager - Phone:</b> Collier County Public Utilities 3301 East Tamiami Trail Naples, Florida 34112 Diana Duerl</p> <p><b>Engineer - Address - Phone:</b> Hazen and Sawyer</p> <p><b>Contract Date:</b> August 1, 2008 <b>Final Contract Amount:</b> In progress <b>Completion Date:</b> In progress <b>Project Description:</b> Procurement and installation of two automatic self-cleaning sand separators (custom built in Germany) including stainless steel piping, valves, instruments and control panels. Installation of system, which included two, three-chamber pump stations, submersible pumps, venturi flowmeters, etc.</p>
<p><b>Project Name:</b> SCRWTP Raw Water Transmission Main &amp; Appurtenances for Raw Water Wells 39S, 40S, 41S &amp; 42S</p> <p><b>Owner - Address - Project Manager - Phone:</b> Collier County Public Utilities Engineering Department 3301 Tamiami Trail, Building H Naples, Florida 34112 Peter Schall</p> <p><b>Engineer - Address - Phone:</b> Hazen &amp; Sawyer 2101 Corporate Boulevard, Suite 301 Boca Raton, Florida 33431 Albert Muniz 561-997-8070</p> <p><b>Contract Date:</b> September 26, 2006 <b>Final Contract Amount:</b> \$1,864,000.00 <b>Completion Date:</b> April 11, 2007 <b>Project Description:</b> Installed 3500 lf of 16-inch HDPE raw water transmission main along with four new raw water wells. This provided the plant the ability to produce sufficient capacity to meet water demands. Included installation of pigging stations and electrical enclosures.</p>	<p><b>Project Name:</b> Decommissioning of Pelican Bay Wastewater Treatment Plant</p> <p><b>Owner - Address - Project Manager - Phone:</b> Collier County Public Utilities Engineering Department 3301 Tamiami Trail East, Building H Naples, Florida 34112 Sandy Sidhar</p> <p><b>Engineer - Address - Phone:</b> Hazen and Sawyer 2101 Corporate Boulevard, Suite 303 Boca Raton, Florida 33431 Kurt Pfeiffer 561-997-8070</p> <p><b>Contract Date:</b> February 8, 2006 <b>Final Contract Amount:</b> \$72,500.00 <b>Completion Date:</b> July 30, 2006 <b>Project Description:</b> Decommissioning of an abandoned Wastewater Treatment Plant</p>
<p><b>Project Name:</b> Pelican Bay Fire and Irrigation Water System Improvement at the Ritz Carlton</p> <p><b>Owner - Address - Project Manager:</b> Collier County Public Utilities Engineering Department 3301 Tamiami Trail East, Building H Naples, Florida 34112 Claude Nesbitt</p> <p><b>Engineer - Address - Phone:</b> Wilson Miller, Inc. 3200 Bailey Lane, Suite 200 Naples, Florida 34105 Craig Pager 800-849-4336</p> <p><b>Contract Date:</b> March 30, 2006 <b>Final Contract Amount:</b> \$182,723.43 <b>Completion Date:</b> February 28, 2007 <b>Project Description:</b> Fire and Irrigation improvements for the Ritz Carlton. Work was coordinated to maintain fire safety at all times.</p>	<p><b>Project Name:</b> Reclaimed Water Aquifer Storage and Recovery</p> <p><b>Owner - Address - Project Manager:</b> Collier County Public Utilities Engineering Department 3301 Tamiami Trail East, Building H Naples, Florida 34112 Alicia Abbott</p> <p><b>Engineer - Address:</b> Water Resource Solution 1368 Colonial Boulevard Fort Myers, Florida 33807 Lloyd Horvath</p> <p><b>Contract Date:</b> April 5, 2006 <b>Final Contract Amount:</b> \$4,658,515.28 <b>Completion Date:</b> June 6, 2007 <b>Project Description:</b> Installed a deep injection well for the storage of reclaimed water coming from Collier County water treatment plants. The Owner will have full capability to recover this reclaimed water for market and/or use for their own irrigation needs.</p>

DOUGLAS N. HIGGINS, INC.  
EXPERIENCE - PAST EIGHT YEARS - GROUP 1

<p><b>Project Name:</b> Tigertail Sewer District Wastewater Collection System Expansion</p> <p><b>Owner - Address - Project Manager - Phone:</b> City of Marco Island 50 Bald Eagle Drive Marco Island, FL 34145 Mr. James Miller 239-389-5011</p> <p><b>Engineer - Address - Phone:</b> Boya Engineering 4415 Metro Parkway, Suite 104 Fort Myers, FL 33918 Fred Mittl 239-278-7996</p> <p><b>Contract Date:</b> March 7, 2006 <b>Final Contract Amount:</b> \$2,920,703.33 <b>Completion Date:</b> December 21, 2006 <b>Project Description:</b> New wastewater collection system including gravity sewer, forcemain, transmission mains, laterals, pump stations, and complete road restoration</p>	<p><b>Project Name:</b> Pads for MBR and Equipment</p> <p><b>Owner - Address - Project Manager - Phone:</b> City of Marco Island 50 Bald Eagle Drive Marco Island, FL 34145 Mr. Bruce Weinstein 239-389-5182</p> <p><b>Engineer - Address - Phone:</b> CDM 9311 College Parkway Fort Myers, FL 33919 Adam Soblanski 239-437-9494</p> <p><b>Contract Date:</b> March 13, 2006 <b>Final Contract Amount:</b> \$183,000.00 <b>Completion Date:</b> May 13, 2006 <b>Project Description:</b> Four structural concrete slabs.</p>
<p><b>Project Name:</b> Rosemary Park Paving &amp; Drainage Improvements</p> <p><b>Owner - Address - Project Manager - Phone:</b> City of Bonita Springs Public Works Department 9101 Bonita Beach Road Bonita Springs, Florida 239-949-6243</p> <p><b>Engineer - Address - Phone:</b> Q. Grady Minor 3800 Via Del Rey Bonita Springs 34134 David Schmitt 239-949-6243</p> <p><b>Contract Date:</b> April 5, 2006 <b>Final Contract Amount:</b> \$631,805.33 <b>Completion Date:</b> November 1, 2006 <b>Project Description:</b> Drainage improvements with RCP pipe and concrete structures.</p>	<p><b>Project Name:</b> Forest Lakes MSTU Phase 2 Drainage Improvements</p> <p><b>Owner - Address - Project Manager - Phone:</b> Collier County - ATM Stormwater Department 2885 Horseshoe Drive South Naples, Florida 34104 Darryl Richard</p> <p><b>Engineer - Address:</b> Wilson Miller 3200 Bailey Lane, Suite 200 Naples, Florida 34105 Craig Pajer</p> <p><b>Contract Date:</b> May 2, 2006 <b>Final Contract Amount:</b> \$193,287.00 <b>Completion Date:</b> July 19, 2006 <b>Project Description:</b> Drainage improvements with RCP and concrete structures.</p>
<p><b>Project Name:</b> Dorch Ave. Drainage &amp; Paving Impvs. Hampton Street Sidewalk Improvements</p> <p><b>Owner - Address - Project Manager - Phone:</b> City of Bonita Springs Public Works Department 9101 Bonita Beach Road Bonita Springs, Florida 239-949-6243</p> <p><b>Engineer - Address - Phone:</b> Q. Grady Minor 3800 Via Del Rey Bonita Springs 34134 David Schmitt 239-949-6243</p> <p><b>Contract Date:</b> March 15, 2006 <b>Final Contract Amount:</b> \$316,400.50 <b>Completion Date:</b> August 1, 2006 <b>Project Description:</b> Drainage improvements with RCP pipe and concrete structures.</p>	<p><b>Project Name:</b> Lehigh Acres Interconnect with The City of Fort Myers</p> <p><b>Owner - Address - Project Manager - Phone:</b> Florida Governmental Utility Authority 280 Wekiva Springs Road, Suite 203 Longwood, Florida 32779</p> <p><b>Engineer - Address - Phone:</b> Malcom Pirnie, Inc. 2301 Maitland Center Parkway, Suite 425 Maitland, Florida 32751 Victor Hurbut 407-659-5550</p> <p><b>Contract Date:</b> June 15, 2006 <b>Final Contract Amount:</b> \$2,884,382.00 <b>Completion Date:</b> April 2007 <b>Project Description:</b> New 8" and 12" watermain including both open cut and directional drilling. Work was performed along a busy thoroughfare.</p>

DOUGLAS N. HIGGINS, INC.  
EXPERIENCE - PAST EIGHT YEARS - GROUP 1

<p><b>Project Name:</b> Pump Station 109 and 113 Improvements</p> <p><b>Owner - Address - Project Manager - Phone:</b> Collier County Public Utilities Engineering 3301 Tamiami Trail East, Building H Sandy Sridhar</p> <p><b>Engineer - Address - Phone:</b> G. Grady Minor &amp; Associates 3800 Via Del Rey Bonita Springs, Florida 34134 David Schmitt</p> <p><b>Contract Date:</b> February 8, 2006 <b>Final Contract Amount:</b> \$ 1,229,561.25 <b>Completion Date:</b> September 29, 2006</p> <p><b>Project Description:</b> New Pump Station &amp; Complete Pump Station Rehab. Work included bypass pumping, structural concrete, precast concrete, electrical/instrumentation, and mechanical.</p>	<p><b>Project Name:</b> Marco Island Wastewater Treatment Plant Expansion - Phase 1 Improvements</p> <p><b>Owner - Address - Project Manager - Phone:</b> City of Marco Island 50 Bald Eagle Drive Marco Island, FL 34145 Mr. Bruce Weinstein 239-389-5182</p> <p><b>Engineer - Address - Phone:</b> CDM 9311 College Parkway Fort Myers, FL 33919 Adam Soblenski 239-437-9494</p> <p><b>Contract Date:</b> May 26, 2006 <b>Final Contract Amount:</b> \$9,787,283.47 <b>Completion Date:</b> January 17, 2007</p> <p><b>Project Description:</b> Included in similar project section</p>
<p><b>Project Name:</b> Appurtenances For Wells RD 101N and 102N</p> <p><b>Owner - Address - Project Manager - Phone:</b> Collier County Public Utilities Engineering 3301 Tamiami Trail East, Building H Naples, Florida 34112 Peter Schall</p> <p><b>Engineer - Address - Phone:</b> Hazen &amp; Sawyer 2101 Corporate Boulevard, Suite 301 Boca Raton, Florida 33431 Albert Muniz</p> <p><b>Contract Date:</b> May 24, 2005 <b>Final Contract Amount:</b> \$597,000.00 <b>Completion Date:</b> January 27, 2006</p> <p><b>Project Description:</b> Complete well installations with exception of the drilled well including pumps, mechanical, and electrical/instrumentation</p>	<p><b>Project Name:</b> Construction of Wells 35 &amp; 36</p> <p><b>Owner - Address - Project Manager - Phone:</b> Collier County Public Utilities Engineering 3301 Tamiami Trail East, Building H Howard Brogdon</p> <p><b>Engineer - Address - Phone:</b> Camp Dresser &amp; McKee, Inc. 9311 College Parkway, Suite 1 Fort Myers, Florida 33919 Adam Sobolewski 239-432-9494</p> <p><b>Contract Date:</b> August 16, 2005 <b>Final Contract Amount:</b> \$998,980.97 <b>Completion Date:</b> January 30, 2006</p> <p><b>Project Description:</b> Complete well installations with exception of the drilled well including pumps, mechanical, and electrical/instrumentation</p>
<p><b>Project Name:</b> 12th Avenue Interconnect Booster PS</p> <p><b>Owner - Address - Project Manager - Phone:</b> Collier County Public Utilities Engineering 3301 Tamiami Trail East, Building H Naples, Florida 34112 Peter Schall</p> <p><b>Engineer - Address - Phone:</b> Hazen and Sawyer 1905 South 25th Street, Suite 103 Fort Pierce, Florida 34947 Albert Muniz</p> <p><b>Contract Date:</b> August 8, 2005 <b>Final Contract Amount:</b> \$1,063,000.00 <b>Completion Date:</b> October 31, 2006</p> <p><b>Project Description:</b> New Wellhead Booster Pump Station including structural concrete, a precast building, mechanical piping, major electrical and instrumentation.</p>	<p><b>Project Name:</b> NCWRF Rebuild filter Set 1 Clean and Paint Filter Beds</p> <p><b>Owner - Address - Project Manager - Phone:</b> Collier County Public Utilities Engineering Department 3301 Tamiami Trail East, Building H Karen Guliani</p> <p><b>Engineer - Address - Phone:</b> Collier County Public Utilities Engineering Department 3301 Tamiami Trail East, Building H Karen Guliani</p> <p><b>Contract Date:</b> March 1, 2005 <b>Final Contract Amount:</b> \$354,817.00 <b>Completion Date:</b> September 14, 2005</p> <p><b>Project Description:</b> Clean out existing filter beds, paint, and install new filter sand.</p>



DOUGLAS N. HIGGINS, INC.  
EXPERIENCE - PAST EIGHT YEARS - GROUP 1

<p><b>Project Name:</b> SCWRF Rehabilitation Piping Odor Control Modifications</p> <p><b>Owner - Address - Project Manager - Phone:</b> Collier County Public Utilities Engineering 3301 Tamiami Trail East, Building H Naples, Florida 34112 Vaughn Williams</p> <p><b>Engineer - Address - Phone:</b> Hole Montes 950 Encore Way Naples, Florida 34110 E. Joseph Goetz, Jr. 239-254-2000</p> <p><b>Contract Date:</b> November 21, 2005 <b>Final Contract Amount:</b> \$217,800.00 <b>Completion Date:</b> July 12, 2006 <b>Project Description:</b> Modifications to the existing Odor Control System</p>	<p><b>Project Name:</b> Michigan Street Drainage Improvements</p> <p><b>Owner - Address - Project Manager - Phone:</b> City of Bonita Springs 9101 Bonita Beach Road Bonita Springs, Florida 34135 239-949-6262</p> <p><b>Engineer - Address - Phone:</b> C. Grady Minor &amp; Associates 3800 Via Del Rey Bonita Springs, Florida 34134 David Schmitt</p> <p><b>Contract Date:</b> January 10, 2005 <b>Final Contract Amount:</b> \$249,610.00 <b>Completion Date:</b> September 1, 2005 <b>Project Description:</b> Drainage improvements with RCP pipe and concrete structures.</p>
<p><b>Project Name:</b> Richview Court Drainage Maintenance</p> <p><b>Owner - Address - Project Manager - Phone:</b> City of Bonita Springs Public Works Department 9101 Bonita Beach Road Bonita Springs, Florida 239-949-6243</p> <p><b>Engineer - Address - Phone:</b> City of Bonita Springs Public Works Department</p> <p><b>Contract Date:</b> December 27, 2005 <b>Final Contract Amount:</b> \$29,333.50 <b>Completion Date:</b> January 30, 2006 <b>Project Description:</b> Drainage improvements with RCP pipe and concrete structures.</p>	<p><b>Project Name:</b> I-75 and Allico Road Interchange Reconstr.</p> <p><b>Owner - Address - Project Manager - Phone:</b> Florida Department of Transportation Tallahassee, Florida</p> <p><b>Engineer - Address - Phone:</b> Engineer: Thomas Boyle 239-432-2732 Contractor: Kiewit Southern 460 Dividend Drive Peachtree City, Georgia 16999 James Whitehead Road Fort Myers, Florida 33912</p> <p><b>Contract Date:</b> October 5, 2005 <b>Final Contract Amount:</b> \$1,288,742.83 <b>Completion Date:</b> June 2007 <b>Project Description:</b> Installed 12,000 LF of 36" Ductile Iron Pipe including jack &amp; bores, and all testing. Work was performed as a subcontractor.</p>
<p><b>Project Name:</b> Culvert Replacement in the River Oaks, Palm River Subdivision</p> <p><b>Owner - Address - Project Manager - Phone:</b> Collier County Stormwater Management 2885 Horseshoe Drive Naples, Florida 34104 Margaret Bishop</p> <p><b>Engineer - Address - Phone:</b> Collier County Stormwater Management</p> <p><b>Contract Date:</b> April 4, 2005 <b>Final Contract Amount:</b> \$576,642.50 <b>Completion Date:</b> July 8, 2005 <b>Project Description:</b> Drainage improvements with RCP pipe and concrete structures.</p>	<p><b>Project Name:</b> Twin Lakes Interconnect</p> <p><b>Owner - Address - Project Manager - Phone:</b> Collier County Stormwater Management 2885 Horseshoe Drive Naples, Florida 34104 Gianfranco Nicolaci</p> <p><b>Engineer - Address - Phone:</b> Agnoli Barber &amp; Brundage, Inc. 7400 Tamiami Trail North, Suite 200 Naples, Florida 34108 Roger Sandrus</p> <p><b>Contract Date:</b> September 12, 2005 <b>Final Contract Amount:</b> \$750,120.75 <b>Completion Date:</b> March 1, 2006 <b>Project Description:</b> Drainage improvements with RCP pipe and concrete structures.</p>

**2011 / 2012  
MONROE COUNTY BUSINESS TAX RECEIPT  
EXPIRES SEPTEMBER 30, 2012**

RECEIPT# 30140-62369

Business Name: DOUGLAS N HIGGINS INC

Owner Name: DOUGLAS N HIGGINS, JAMES SWEET QUAL Business Location: MO CTY  
 Mailing Address: 3390 TRAVIS POINTE RD KEY WEST, FL 33040  
 Ste A Business Phone: 305-294-3355  
 ANN ARBOR, MI 48108 Business Type: CONTRACTORS (UNDERGROUND UTILITY)

**Rooms                      Seats                      Employees                      Machines                      Stalls**

5

STATE LICENSE: CUC057447 EX

Number of Machines:		For Vending Business Only			Vending Type:		
Tax Amount	Transfer Fee	Sub-Total	Penalty	Prior Years	Collection Cost	Total Paid	
20.00	0.00	20.00	0.00	0.00	0.00	0.00	20.00

Paid 118-10-00000744 07/08/2011 20.00

**THIS RECEIPT MUST BE POSTED CONSPICUOUSLY IN YOUR PLACE OF BUSINESS**

THIS BECOMES A TAX RECEIPT  
WHEN VALIDATED

**Danise D. Henriquez, CFC, Tax Collector  
PO Box 1129, Key West, FL 33041**

THIS IS ONLY A TAX.  
YOU MUST MEET ALL  
COUNTY AND/OR  
MUNICIPALITY PLANNING  
AND ZONING REQUIREMENTS.

# CITY OF KEY WEST, FLORIDA

## Business Tax Receipt

This Document is a business tax receipt  
Holder must meet all City zoning and use provisions.  
P.O. Box 1409, Key West, Florida 33040 (305) 809-3955

Business Name DOUGLAS N. HIGGINS (CGC) CtlNbr:0018021  
Location Addr 3390 TRAVIS POINTE STE A RD  
Lic NBR/Class 12-00022114 CONTRACTOR - CERT GENERAL CONTRACTOR  
Issue Date: July 15, 2011 Expiration Date: September 30, 2012  
License Fee \$309.75  
Add. Charges \$0.00  
Penalty \$0.00  
Total \$309.75  
Comments:

---

This document must be prominently displayed.

DOUGLAS N. HIGGINS, INC

DOUGLAS N. HIGGINS (CGC)  
3390 TRAVIS POINTE STE A RD  
ANN ARBOR MI 48108

Oper: CWALKER Type: DC Drawer: 1  
Date: 7/18/11 54 Receipt no: 86071  
2012 22114  
OR LIC OCCUPATIO 1 \$309.75  
Trans number: 2652607  
CK CHECK 15938 \$619.50  
Trans date: 7/18/11 Time: 0:41:36

CERTIFICATE OF SECRETARY

The undersigned, being the duly elected secretary of Douglas N. Higgins, Inc., a Michigan corporation, hereby certifies that the following resolution was duly adopted by the Board of Directors of said corporation at a meeting held on May 15, 2012 and that said resolution is in full force and effect:

"RESOLVED, That the following listed persons are hereby authorized to execute, on behalf of Douglas N. Higgins, Inc., any and all contracts and documents."

Douglas N. Higgins

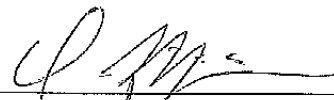

Daniel N. Higgins



William D. Higgins

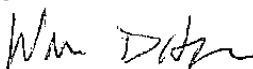

James H. Sweet

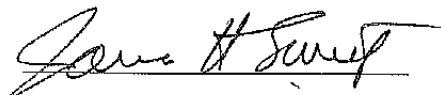

Kelly A. Wilkie

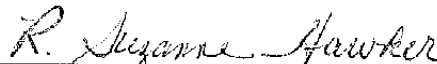
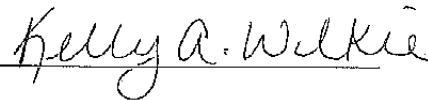

R. Suzanne Hawker  
Secretary

Dated: May 15, 2012

# *State of Florida*

## *Department of State*

I certify from the records of this office that DOUGLAS N. HIGGINS INC. is a corporation organized under the laws of Michigan, authorized to transact business in the State of Florida, qualified on August 1, 1973.

The document number of this corporation is 830666.

I further certify that said corporation has paid all fees due this office through December 31, 2012, that its most recent annual report was filed on January 17, 2012, and its status is active.

I further certify that said corporation has not filed a Certificate of Withdrawal.

*Given under my hand and the Great Seal of  
Florida, at Tallahassee, the Capital, this the  
Eighteenth day of January, 2012*

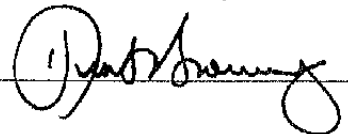

*Secretary of State*



Authentication ID: 000218635270-011812-830666

To authenticate this certificate, visit the following site, enter this ID, and then follow the instructions displayed.

<https://efile.sunbiz.org/certauthver.html>



STATE OF FLORIDA

DEPARTMENT OF BUSINESS AND PROFESSIONAL REGULATION

CONSTRUCTION INDUSTRY LICENSING BOARD
1940 NORTH MONROE STREET
TALLAHASSEE FL 32399-0783

(850) 487-1395

HIGGINS, DANIEL NORMAN
DOUGLAS N HIGGINS INC
3390 TRAVIS POINTE ROAD
SUITE A
ANN ARBOR MI 48108

Congratulations! With this license you become one of the nearly one million Floridians licensed by the Department of Business and Professional Regulation.

Every day we work to improve the way we do business in order to serve you better. For information about our services, please log onto www.myfloridalicense.com.

Our mission at the Department is: License Efficiently, Regulate Fairly. We constantly strive to serve you better so that you can serve your customers.

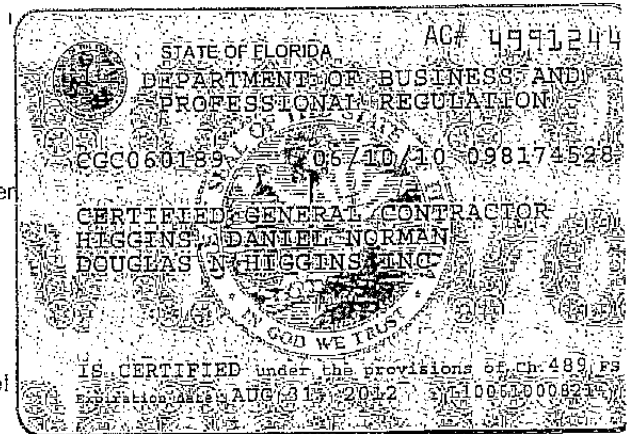

DETACH HERE

License details section including AC# 4991244, State of Florida Department of Business and Professional Regulation, Construction Industry Licensing Board, license table with columns DATE, BATCH NUMBER, LICENSE NBR, and signature lines for CHARLIE CRIST and CHARLIE LIEM.

# IMPASSE

## HIGH SECURITY STEEL PALISADE FENCING

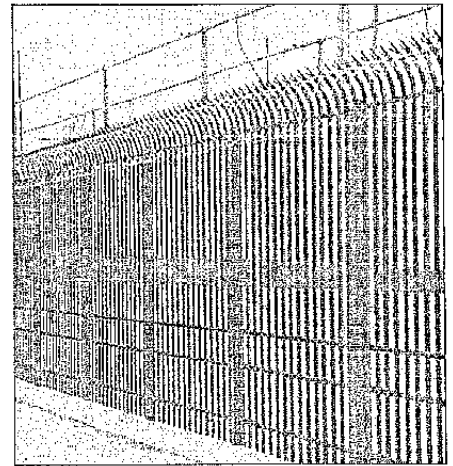
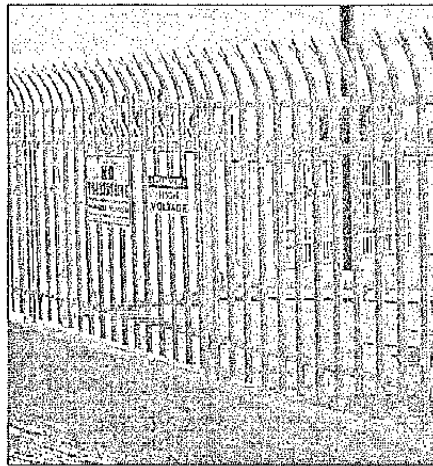
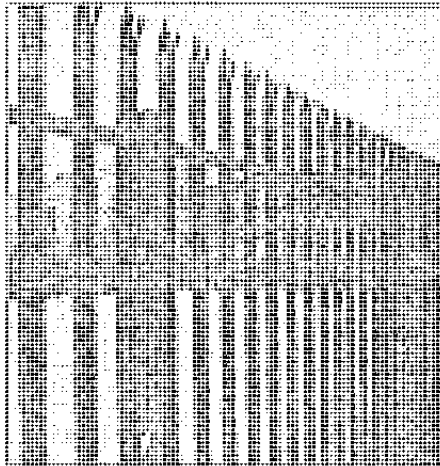

### THE FIRST LINE OF DEFENSE

Ameristar Fence Products is the world's leader for developing new products to help secure and protect at risk facilities. The Impasse high security fence system is a heavy steel palisade fence system designed to provide the end user with a level of security not typically achieved with traditional chain link or architectural mesh fence systems.

#### DETER

The high-tensile steel corrugated pales provide a daunting appearance that towers above the rails of the Impasse framework. Each connection point of the Impasse system is secured with tamper-proof fasteners providing the highest level of security and versatility.

#### DETECT

The unique design of the Impasse rail enables the fence system to become a platform for multiple security peripherals.

#### DELAY

The Impasse security fence offers the resistive strength of heavy-duty steel spears secured vertically to a framework of specially formed steel rails and I-beam Posts.

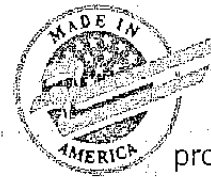

We take great pride in manufacturing "Made in the USA" products. Ameristar is located in Tulsa, Oklahoma and is American owned and operated.

#### Applications:

- Military Sites
- Government Facilities
- Petroleum & Chemical Facilities
- Power Plants & Substations
- Airports
- Data Centers
- Ports of Entry
- Water Treatment & Storage

Covered by or for use with one or more of the following U.S. patents: 4,874,767, 5,189,826, 7,441,673

**AMERISTAR FENCE PRODUCTS**

# IMPASSE

## HIGH SECURITY STEEL PALISADE FENCING

### PANELS & POSTS

Impasse panels and posts are manufactured using high-tensile pre-galvanized G-90 steel. Each component has been roll-formed into a unique profile that yields significant strength properties.

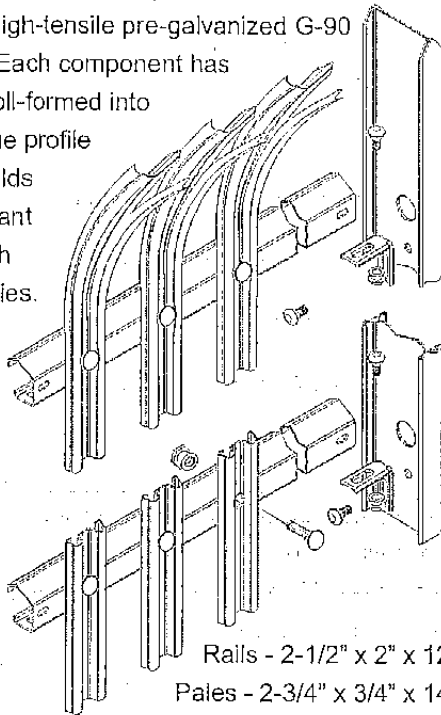

Rails - 2-1/2" x 2" x 12ga.

Pales - 2-3/4" x 3/4" x 14ga.

I-beam Posts - 1-3/4" x 4" x 12ga.

### INTEGRATION

The Impasse rail can be used as a platform for multiple perimeter security elements. The Impasse framework is a raceway for wiring, conduits, and/or security cabling required around the perimeter of a project. This integrated design eliminates the need for costly trenching and boring becoming a value added solution for perimeter security upgrades.

When installing the security elements use Impasse as a platform:



Communication & Video cables  
Intrusion Detection / Fiber Optic Cables  
Access Control Wiring  
Conduits  
Anti-ram Cabling (Stalwart)

### COATING & WARRANTY

Impasse is coated using Ameristar's PermaCoat process, this dual-coat finish yields the best results for durability and weathering in the fence industry. Ameristar has over 25 years of experience and research in coating fence products allowing Impasse to support a 15 year warranty.

### STYLES

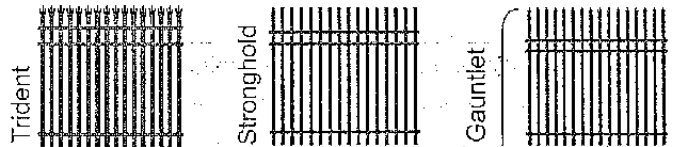

Also available in Impasse Anti-Scale pale spacing - 1.5" airspace

### DESIGN

Impasse's distinct design enables the fence to traverse aggressive changes in grade in order to maintain security along any perimeter. Each connection point of the Impasse system is secured with tamper-proof fasteners providing the highest level of security and versatility.

### GATES

Ameristar understands the importance of balancing perimeter security with the highest quality entry control gates. Impasse has a wide variety of Swing, Slide, and Cantilever Gates to match any Entry.



Impasse is produced using up to 96% post-industrial recycled steel.

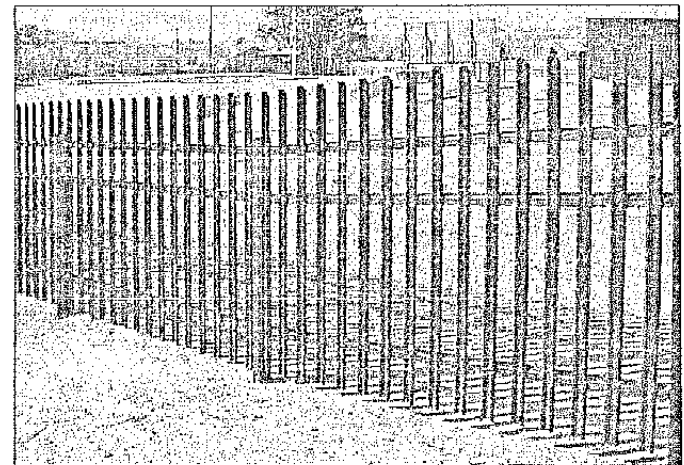

Effective: 08/2010

AMERISTAR FENCE PRODUCTS  
1555 N. Mineral Rd.  
TULSA, OK 74116

AMERISTARFENCE.COM

PH: 888-888-3422  
MKTG@AMERISTARFENCE.COM



FLORIDA BID BOND

BOND NO. \_\_\_\_\_

AMOUNT: \$ 5% \_\_\_\_\_

KNOW ALL MEN BY THESE PRESENTS, that Douglas N. Higgins, Inc.

hereinafter called the Contractor (Principal), and Hartford Fire Insurance Compay

a corporation duly organized and existing under and by virtue of the laws of the State of Florida, hereinafter called the Surety, and authorized to transact business within the State of Florida, as Surety, are held and firmly bound unto The City of Key West as Owner

(Obligee), in the sum of: five percent of attached bid

\_\_\_\_\_ DOLLARS (\$ 5% \_\_\_\_\_), for the payment for which we bind ourselves, our heirs, executors, administrators, successors, and assigns, jointly and severally, firmly by these presents.

THE CONDITION OF THIS BOND IS SUCH THAT:

WHEREAS, the Principal is herewith submitting his or its Bid Proposal for **FENCING REPLACEMENT TRUMAN ANNEX.**

WHEREAS, the Principal contemplates submitting or has submitted a bid to the Obligee for the furnishing of all labor, materials (except those to be specifically furnished by the Owner), equipment, machinery, tools, apparatus, means of transportation for, and the performance of the work covered in the Proposal and the detailed Drawings and Specifications, entitled:

ITB#12-029: Ornamental Fencing Replacement NASKW

WHEREAS, it was a condition precedent to the submission of said bid that a cashier's check, certified check, or bid bond in the amount of 5 percent of the base bid be submitted with said bid as a guarantee that the Bidder would, if awarded the Contract, enter into a written Contract with the Owner for the performance of said Contract, within 10 working days after written notice having been given of the award of the Contract.

NOW, THEREFORE, the conditions of this obligation are such that if the Principal within 10 consecutive calendar days after written notice of such acceptance, enters into a written Contract with the Obligee and furnishes the Performance and Payment Bonds, each in an amount equal to 100 percent of the awarded base bid, satisfactory to the Owner, then this obligation shall be void; otherwise the sum herein stated shall be due and payable to the Obligee and the Surety herein agrees to pay said sum immediately upon demand of the Obligee in good and lawful money of the United States of America, as liquidated damages for failure thereof of said Principal.

Signed and sealed this 18th day of July, 2012



Dale A. Bell  
Fl. Resident Agent  
Sullivan & Co. 2001 NW 37th Ave.  
Miami, FL 33172 305 491 7000

Douglas N. Higgins, Inc.  
Principal

By: Kelly A. Wilkie  
Kelly A. Wilkie, Vice-President  
Hartford Fire Insurance Company

Surety  
By: Heather M. Johnson  
Attorney-In-Fact Heather M. Johnson

END OF SECTION

# POWER OF ATTORNEY

Direct Inquiries/Claims to:

THE HARTFORD  
BOND, T-4  
One Hartford Plaza  
Hartford, Connecticut 06155

call: 888-266-3488 or fax: 860-757-5835

Agency Code: 35-350851

**KNOW ALL PERSONS BY THESE PRESENTS THAT:**

- Hartford Fire Insurance Company, a corporation duly organized under the laws of the State of Connecticut
- Hartford Casualty Insurance Company, a corporation duly organized under the laws of the State of Indiana
- Hartford Accident and Indemnity Company, a corporation duly organized under the laws of the State of Connecticut
- Hartford Underwriters Insurance Company, a corporation duly organized under the laws of the State of Connecticut
- Twin City Fire Insurance Company, a corporation duly organized under the laws of the State of Indiana
- Hartford Insurance Company of Illinois, a corporation duly organized under the laws of the State of Illinois
- Hartford Insurance Company of the Midwest, a corporation duly organized under the laws of the State of Indiana
- Hartford Insurance Company of the Southeast, a corporation duly organized under the laws of the State of Florida

having their home office in Hartford, Connecticut, (hereinafter collectively referred to as the "Companies") do hereby make, constitute and appoint, **up to the amount of unlimited:**

*Heather M. Johnson, Joel E. Speckman, Terri Mahakian, David Harlock*  
of  
*Ann Arbor, MI*

their true and lawful Attorney(s)-in-Fact, each in their separate capacity if more than one is named above, to sign its name as surety(ies) only as delineated above by , and to execute, seal and acknowledge any and all bonds, undertakings, contracts and other written instruments in the nature thereof, on behalf of the Companies in their business of guaranteeing the fidelity of persons, guaranteeing the performance of contracts and executing or guaranteeing bonds and undertakings required or permitted in any actions or proceedings allowed by law.

In Witness Whereof, and as authorized by a Resolution of the Board of Directors of the Companies on January 22, 2004 the Companies have caused these presents to be signed by its Assistant Vice President and its corporate seals to be hereto affixed, duly attested by its Assistant Secretary. Further, pursuant to Resolution of the Board of Directors of the Companies, the Companies hereby unambiguously affirm that they are and will be bound by any mechanically applied signatures applied to this Power of Attorney.



*Wesley W. Cowling*

Wesley W. Cowling, Assistant Secretary

*M. Ross Fisher*

M. Ross Fisher, Assistant Vice President

STATE OF CONNECTICUT }  
COUNTY OF HARTFORD } ss. Hartford

On this 3<sup>rd</sup> day of November, 2008, before me personally came M. Ross Fisher, to me known, who being by me duly sworn, did depose and say: that he resides in the County of Hartford, State of Connecticut; that he is the Assistant Vice President of the Companies, the corporations described in and which executed the above instrument; that he knows the seals of the said corporations; that the seals affixed to the said instrument are such corporate seals; that they were so affixed by authority of the Boards of Directors of said corporations and that he signed his name thereto by like authority.



CERTIFICATE

*Scott E. Paseka*

Scott E. Paseka  
Notary Public

My Commission Expires October 31, 2012

I, the undersigned, Assistant Vice President of the Companies, DO HEREBY CERTIFY that the above and foregoing is a true and correct copy of the Power of Attorney executed by said Companies, which is still in full force effective as of July 18, 2012.  
Signed and sealed at the City of Hartford.



*Gary W. Stumper*

Gary W. Stumper, Assistant Vice President