

PLANT LIST

QTY	SYM	DESCRIPTION
6	TR	THRINAX RADIATA "FLORIDA THATCH"
14	EF	EUGENIA FOETIDA "SPANISH STOPPER"
12	TM	THRINAX MORRSII "KEYS THATCH"
8	BS	BURSERA SIMARUBA "GUMBO LIMBO"
1	CES	CONOCARPUS ERECTUS SERICESUS "SILVER BUTTWOOD"
6	SP	SABAL PALMETTO "CABBAGE PALM"
3	DR	DELONIX REGIA "POINCIANA"
34	RP	RAPANEA PUNCTATA "MYRSINE"
10	ER	EUGENIA RHOMBEA "RED STOPPER"
9	CW	CANELLA WINERANA "WILD CINNAMON"
28	MF	MYRICANTHUS FRAGRANS "SIMPSON STOPPER"
72	PN	PSYCHOTRIA LIGUSTRIFOLIA "DWARF COFFEE"
26	CER	CODIAEUM "ELEANORE ROOSEVELT CROTON"
32	SA	SAVIA BAHAMENSIS "MAIDENBUSH"
39	IC	IXORA COCCINEA "IXORA SUPER KING"
37	JC	CAPPARIS CYNOPHALLOPHORA "JAMAICAN CAPER"
23	MUG	MUHLENBERGIA CAPILLARIS "MUHLY GRASS"
138	FAX	TRIPSACUM DACTYLAIDES "DWARF FAKAHATCHEE"
1	ZF	ZANTHOXYLUM FLAVUM "YELLOWHEART"

LEGEND

ABBREVIATION	TREES
GL	GUMBO LIMBO
BO	BLACK OLIVE
PO	POINCIANA
WT	WOMEN'S TONGUE
CP	COCONUT PALM
CMP	CHRISTMAS PALM
BC	BARBADOS CHERRY
BW	BUTTONWOOD
FB	FIGUS BENJAMIN
FC	FIGUS CITROFOLIA
B	BISMARCK PALM
PP	PIGEON PLUM
A	ARECA
W	WASHINGTONIAN
KI	KEYS THATCH
TP	TRIANGLE PALM
TAB	TABEBUIA
E	FRANGIPANI
BC	BAY CEDAR
TRP	TRAVELERS PALM
SB	SILVER BUTTWOOD
SS	SPANISH STOPPER

TRANSPLANTED MATERIALS - TREE RELOCATION SPECIFICATIONS:

1. Locating and verifying all existing underground utilities before any trees are installed and coordinated closely with respective utility contractors involved in those certain areas.
2. If any tree should shock and die it is to be removed and replaced with like species and size, as directed by the Landscape Architect and Owner.
3. Water in trees. See Landscape Installation Specifications.
4. Providing Cypress Mulch, peat, potting soil and fertilizer on site so that proper planting is being done.
5. Guarantee that all relocated trees will survive for one year.
6. Inspect all plant material for insect/disease problem.

NOTE:
ALL WORK PERFORMED WITHIN AN EASEMENT OR A PUBLIC RIGHT-OF-WAY REQUIRES A SEPARATE PERMIT BY THE DEPT OF PUBLIC WORKS. PROVIDE A MIN. 3' CLEARANCE FROM THE EDGE OF DRIVEWAYS TO ANY SUCH STRUCTURE SUCH AS INLETS, TRANSFORMERS, POLES, ETC., IN RIGHT-OF-WAY EASEMENT. CONTACT SURVIVOR AND ANY OTHER GOVERNMENTAL AGENCIES PRIOR TO WORK IN JURISDICTIONAL WETLANDS.

48 HOURS BEFORE YOU DIG
CALL SURVIVOR
1-800-432-4770
IT'S THE LAW IN FLORIDA

JANET O. WHITMILL, R.L.A., INC.
LANDSCAPE ARCHITECTURE * PLANNING
P.O. BOX 9212, JACKSONVILLE, FL. 32247 (904) 398-7688

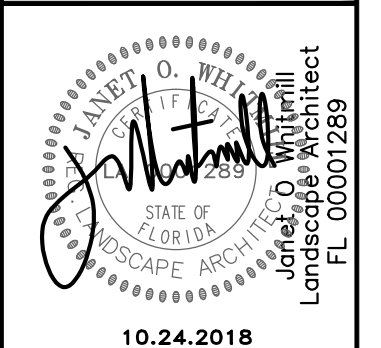

MARTY'S PLACE
NEW DEVELOPMENT
JACKSONVILLE, FLORIDA

LANDSCAPE PLAN
05.21.18

© JANET O. WHITMILL, R.L.A., INC.
Copyright, Janet O. Whitmill, R.L.A., Inc.
All rights reserved. No part of this work may be used, reproduced, distributed, displayed or otherwise communicated in any form or by any means without the prior written consent of Janet O. Whitmill, R.L.A., Inc.

NO.	DATE	DESCRIPTION
5	10.24.18	100% CONSTRUCTION DOCUMENTS
4	09.24.18	FINAL COMMISSION COMMENTS
3	08.31.18	TREE COMMISSION COMMENTS
2	07.26.18	LANDSCAPE COORDINATION
1	07.19.18	ARBORIST ASSESSMENT

JOB NO. 23318
DRAWN: DHM
CHECKED: JOW
SCALE: 1:10
DRAWING NO. L-1

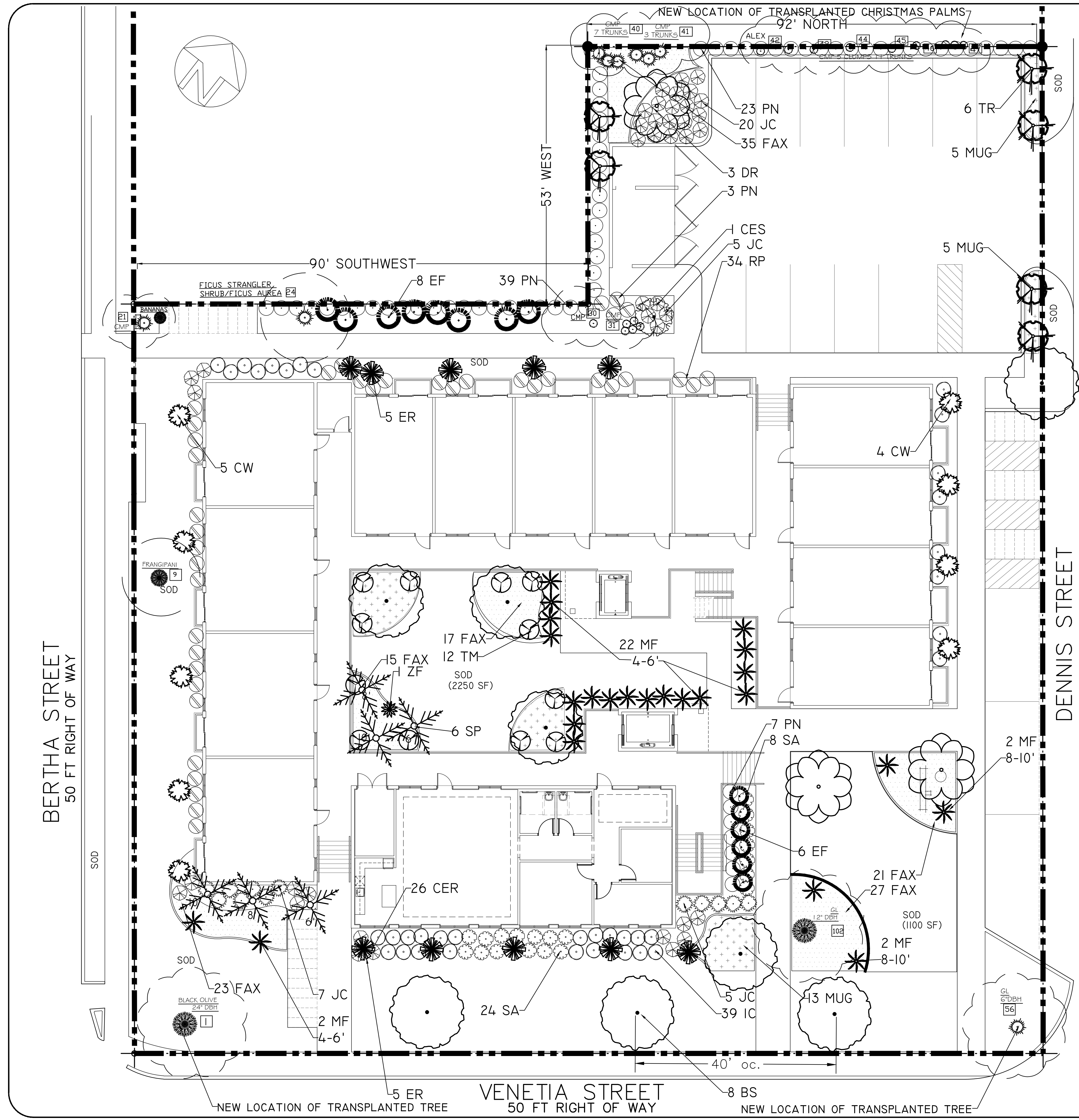

PLANT LIST

QTY	SYM	DESCRIPTION	SIZE	SPACING	NOTES*
6	TR	THRINAX RADIATA "FLORIDA THATCH"	8' x 4-5', FULL, SPECIMEN, MATCHED	AS SHOWN	N, FYN, FF, WW
14	EF	EUGENIA FOETIDA "SPANISH STOPPER"	6-8' x 3-4', 1-2" CAL., STD., SPECIMEN, MATCHED	AS SHOWN	N, FYN, FF, WW
12	TM	THRINAX MORRSII "KEYS THATCH"	4-6' x 3-4', FULL, SPECIMEN, MATCHED	AS SHOWN	N, FYN, FF, WW
8	BS	BURSERA SIMARUBA "GUMBO LIMBO"	14'-16' x 7-8', 4" CAL., 4' CT., STD., MATCHED	AS SHOWN	N, FYN, FF, WW
1	CES	CONOCARPUS ERECTUS SERICESUS "SILVER BUTTONWOOD"	10'-12' x 3-4' 2" CAL., FTG, STD., MATCHED	AS SHOWN	N, FYN, FF, WW
6	SP	SABAL PALMETTO "CABBAGE PALM"	10', 12, 14 CT., REG HEAD, BOOTED, MATCHED	AS SHOWN	N, FYN, FF, WW
3	DR	DELONIX REGIA "POINCIANA"	14'-16' x 5-7', 4" CAL., STD., SPECIMEN, MATCHED	AS SHOWN	FYN, FF, WW
34	RP	RAPANEA PUNCTATA "MYRSINE"	3-4' x 24", FULL, MATCHED	AS SHOWN	N, FYN, FF, WW
10	ER	EUGENIA RHOMBEA "RED STOPPER"	6-8' x 3-4', 1" CAL., STD., FULL, SPECIMEN	AS SHOWN	N, FYN, FF, WW
9	CW	CANELLA WINERANA "WLD CINNAMON"	6-8' x 4-5', 1-2" CAL., STD., FULL, MATCHED	AS SHOWN	N, FYN, FF, WW
28	MF	MYRICANTHUS FRAGRANS "SIMPSON STOPPER"	4-6' 1" CAL & 8-10' 2" CAL, STD., FULL, MATCHED	AS SHOWN	N, FYN, FF, WW
72	PN	PSYCHOTRIA LIGUSTRIFOLIA "DWARF COFFEE"	24" x 24", FULL, MATCHED	36" OC.	N, FYN, FF, WW
26	CER	CODIAEUM "ELEANORE ROOSEVELT CROTON"	24" x 24", FULL, MATCHED	36" OC.	FYN, FF, WW
32	SA	SAVIA BAHAMENSIS "MAIDENBUSH"	36" x 24", FULL, MATCHED	36" OC.	N, FYN, FF, WW
39	IC	IXORA COCCINEA "IXORA SUPER KING"	18" x 18", FULL, MATCHED	36" OC.	FYN, FF, WW
37	JC	CAPPARIS CYNOPHALLOPHORA "JAMAICAN CAPER"	60" x 24", 1-2" CAL., FULL, MATCHED	36" OC.	N, FYN, FF, WW
23	MUG	MUHLENBERGIA CAPILLARIS "MUHLY GRASS"	24", 3-5 BIBS, FULL, MATCHED	36" OC.	N, FYN, FF, WW
138	FAX	TRIPSACUM DACTYLAIDES "DWARF FAKAHATCHEE"	24" x 24", MIN 5 BIBS, FULL, MATCHED	36" OC.	N, FYN, FF, WW
1	ZF	ZANTHOXYLUM FLAVUM "YELLOWHEART"	8-10' x 3-4", 2" CAL., STD., FULL MATCHED	AS SHOWN	N, FYN, FF, WW

SOD STENITAPHRUM SECUNDATUM "ST AUGUSTINE PALMETTO"
 SOD ALL 4:1 SLOPES OR GREATER, 10' FROM EOP AND ALL DISTURBED ROW. COORDINATE FURTHER GRASSING WITH GENERAL CONTRACTOR
 SELECTED SOD SPECIES MEETS ALL CURRENT LANDSCAPE AND IRRIGATION REQUIREMENTS. ANY VARIABLE WILL REQUIRE GOVERNMENT APPROVAL

*PLANT LIST LEGEND: N-NATIVE, FYN- FLORIDA YARDS & NEIGHBORHOODS 2006, FF- FLORIDA FRIENDLY, WW- WATER WISE
 *ALL TREES, PALM, SHRUBS AND GROUND COVER SHALL BE FLA. NO. 1 OR BETTER.

48 HOURS BEFORE YOU DIG
 CALL SUNSHINE
 1-800-432-4770
 IT'S THE LAW IN FLORIDA

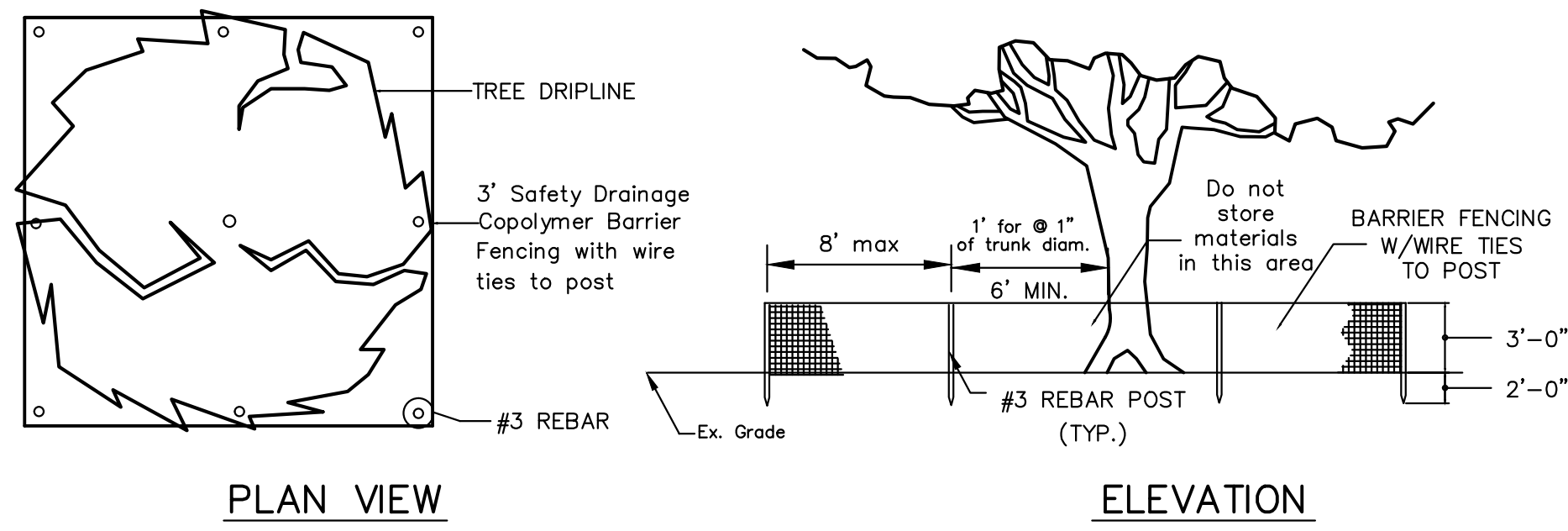
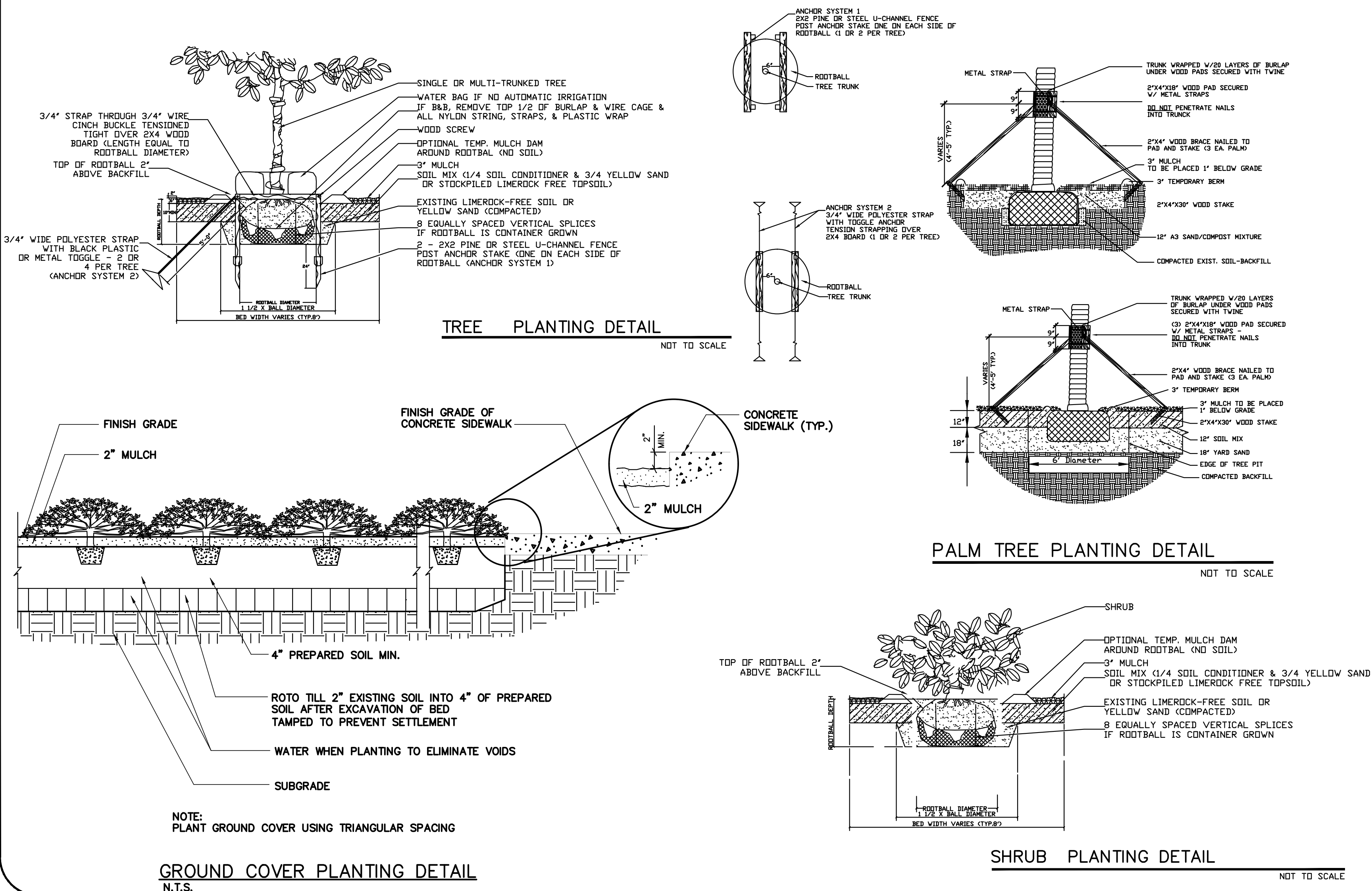

TREE PROTECTION FENCING DETAIL

THE TREE PROTECTION BARRICADE SHALL BE AT LEAST THREE (3) FEET HIGH. THE BARRIER SHALL CONSIST OF EITHER WOOD FENCE WITH 2X4 POSTS PLACED A MAXIMUM EIGHT (8) FEET APART, WITH A 2X4 MINIMUM TOPRAIL, OR A TEMPORARY WIRE MESH FENCE, OR OTHER SIMILAR BARRIER WHICH WILL LIMIT ACCESS TO PROTECTED AREA.

THE BARRICADE SHALL BE AT LEAST TO THE DRIPLINE OF THE TREE.

TREE BARRICADE APPROVAL: OBTAIN CITY APPROVAL OF TREE BARRICADES BEFORE BEGINNING CLEARING OPERATIONS OR ANY SITE DEVELOPMENT.

PLANTING NOTES

- The LANDSCAPE CONTRACTOR is responsible for verifying project site conditions and all quantities indicated on these plans before commencing any work. LANDSCAPE CONTRACTOR shall notify the LANDSCAPE ARCHITECT if soil conditions are poorly drained to determine if substitution of materials is necessary.
- Soil tests shall be provided to evaluate various areas of the landscape (especially the parking lot islands) for pH, available nutrients, phosphorus content, bulk density, etc. This will serve to ensure proper plant selection according to prevailing soil conditions, what lime/sulphur applications are needed (if any) and long-term survival of plant material.
- All plant material shall be Florida Grade No. 1 or better nursery grown in accordance to Florida Grades and Standards handbook.
- All plant material shall be container grown or B&B. B&B materials shall be "hardened off" root pruned during field production and shall be dug at least several weeks before planting is performed.
- Plants shall be sound, healthy and vigorous, well branched and densely foliated when in leaf. They shall be free of disease, insects, eggs or larvae and shall have healthy, well developed root systems. They shall be free from physical damage or adverse conditions that would prevent thriving growth.
- All plants shall conform to the varieties indicated in the plant list.
- Substitution of plant materials will not be permitted unless authorized in writing by the LANDSCAPE ARCHITECT. If proof is submitted that any plant specified is not obtainable, a proposal will be considered for use of the nearest equivalent size or variety with corresponding adjustment of contract price.
- Plant material locations and bed outlines shall be staked or flagged on site by the CONTRACTOR and shall be adjusted if required to fit actual as-built conditions on site and approved by the owner or owners representative.
- All proposed tree planting locations shall be staked or flagged before installation by the LANDSCAPE ARCHITECT and approved by the owner or owners representative.
- The CONTRACTOR shall estimate the depth of the planting hole by measuring the distance between the point where the topmost root emerges from the trunk and the bottom of the root ball. The planting hole shall be slightly shallower than this distance. No more than 2 to 3 inches of the root ball needs to be above the soil unless the site is poorly drained. Poorly drained soil requires planting depths even or higher. Planting holes dug too deep are required to have soil added to the bottom and loosely compacted. If planting holes shall fill with water as it is dug, position the bottom of the root ball above the water and mound soil to cover the sides of the ball. The hole shall be at least 1.5 times the diameter of the root ball. Wider holes shall be used for compacted soil and wet sites.
- The soil shall be freshly tilled and large clods of soil broken up. The growing medium shall be settled and firm at the time of herbicide application. Herbicides may be mechanically incorporated by mixing into top layer at a depth of 1-3 inches.
- All backfill around plant material shall be worked firmly by slicing a shovel down into the backfill 20 to 30 times around the tree as you add backfill soil. Large clumps shall be broken up. Do not pack the backfill. Only step firmly on backfill soil to stabilize the root ball. The top of the root ball shall remain 1 inch (small trees) to 3 inches (large trees) or approximately 10% above grade. Do not over-pack the loosened soil when wet. Add 10 to 20 gallons of water to the rootball and backfill. Fill in any holes or depressions with backfill soil. Do not attempt to eliminate air pockets by compaction. Water infiltrating the backfill soil will eliminate large air pockets.
- LANDSCAPE CONTRACTOR shall bear final responsibility for proper surface drainage of planted areas. Any discrepancy in the drawings, obstruction on the site, or prior to work done by any other party, which the CONTRACTOR feels precludes establishing proper drainage shall be brought to the attention of the LANDSCAPE ARCHITECT for correction or relief of said responsibility.
- When planting on slopes, set tree so top-most root in the ball on the uphill side is even with the soil. The side of the root ball on the downhill side will be well above the surrounding soil. Soil shall cover the sides of the root ball. Mulch shall cover the edge of the rootball and not piled on top.
- Planting beds shall be cut or edged to form a uniform clean line between beds and lawn areas.
- After all plant material in a plant bed area has been installed and approved, the areas between plants shall be raked to an even grade to conform to premulching finish grades. All planting beds and plant saucers shall then be uniformly covered with a minimum depth of three (3) inches of #2 grade or better of ECO MULCH with a maximum diameter of two (2) inches. Contractor to provide a sample prior to installation.
- Before fertilization a soil and/or foliar nutrient analysis shall be performed to determine whether phosphorus fertilizer with 30% slow release nitrogen will be required. All planting bed areas shall be fertilized approximately 4-6 weeks after installation.
- Plant material soil shall be "native" soil that was removed from the planting hole. If soil is badly contaminated, good quality soil shall be used as replacement after contaminated soil has been completely removed from planting area.
- After sodding is completed, the entire site areas shall be watered by hand or irrigation system each day for two weeks. After approximately one month of installation, sodded areas shall then be top dressed with a 15-0-15 commercial slow-release fertilizer at a rate of 6.67 pounds per 1,000 square feet of area in an evenly broad-case pattern.
- The LANDSCAPE CONTRACTOR is responsible for all fine grading preparation for planting. Apply pre-emergent to all beds prior to planting.
- Rough grades will be established by the owners general contractor at approximately 3 inches below curbs, sidewalks, hardscape amenities, mowing strips and abutments. All materials shall be a minimum 30" from buildings or walks.
- CONTRACTOR shall coordinate construction of planting areas with installation of irrigation system.
- Where seeding may be required on the plans, germination rate shall be the maximum percentage required for the variety specified at the rate of application specified.
- Sod areas shall be SPECIFIED Grass. Grass for sodding shall be freshly cut in squares one foot wide by two feet long. Sod shall be healthy, free of insects and weeds, in naturally flourishing conditions. Dry, brown and unrefresh sod will be rejected.
- Sod shall be laid end to end and side to side in a staggered line to form a uniform layer. All uneven edges shall be squarely trimmed to allow close and firm fitting of each piece.
- After sodding is completed, the entire sod areas shall be watered by hand or irrigation system each day for two weeks. Sodded areas shall then be top dressed with a commercial fertilizer as directed herein at the rate of 12 pounds per 1000 square feet of area in an evenly broad case pattern.
- The LANDSCAPE CONTRACTOR is responsible for fully maintaining all plant material on site during and before planting, until the work is accepted by the LANDSCAPE ARCHITECT and/or owner. The LANDSCAPE CONTRACTOR is responsible for removing tree stakes after tree is established.
- All plants shall be guaranteed by the LANDSCAPE CONTRACTOR to be healthy plants and in flourishing condition of active growth for ninety (90) days from final inspection and acceptance. All trees shall be guaranteed an additional one year from final inspection and acceptance.
- The LANDSCAPE ARCHITECT, owner or owners representative shall have the right to reject any and all work which in his opinion does not meet with the requirements of the specifications at any stage of the project operation.
- In general, the work shall proceed as rapidly as the site becomes available. Keep all areas of work clean, neat, and orderly at all times.
- There will be special care to all existing trees to be retained on site to avoid construction damage.
- An automatic irrigation system is to be provided and a shop drawing of the layout and design must be submitted to the governmental agency, for review and approval, prior to installation.
- Irrigation system shall be fully automatic, providing 100% coverage to all planting areas, with all pop up heads in lawn area.
- Irrigation station shall be set where there will be no mixing of shrub and lawn areas, fixed spray heads with gear driven heads or impacts. Shrub risers shall be minimum 2.5' from eop and all heads minimum 2' from buildings.
- A double check backflow prevention (or approved equal); equal to a DCA-100; to be mounted in a rectangular valve box (12"x 10") on the service side of the meter and immediately adjacent to the water meter.
- After the landscape plan is approved by the governmental agency any subsequent changes must be resubmitted for review and approval.
- Shade trees shall be planted minimum 4' from EOP and 15' from OHE.
- Do not plant trees below Normal Water Line (NWL) see civil drawings. Sod all 4:1 or greater slopes. Seed all other disturbed areas.

JANET O. WHITMILL, R.L.A., INC.
 LANDSCAPE ARCHITECTURE + PLANNING
 P.O. BOX 5212, JACKSONVILLE, FL 32247 (904) 398-7688

MARTY'S PLACE
 NEW DEVELOPMENT
 JACKSONVILLE, FLORIDA

LANDSCAPE DETAILS PLAN
 05.21.18

NO.	DATE	DESCRIPTION
1	07.19.18	ARBORIST ASSESSMENT
2	08.11.18	LANDSCAPE COORDINATION
3	08.11.18	TREE COMMISSION COMMENTS
4	09.24.18	FINAL COMMISSION COMMENTS
5	10.24.18	100% CONSTRUCTION DOCUMENTS

JOB NO. 23318
 DRAWN: DHM
 CHECKED: JOW
 SCALE: 1:10
L-2
 DRAWING NO.

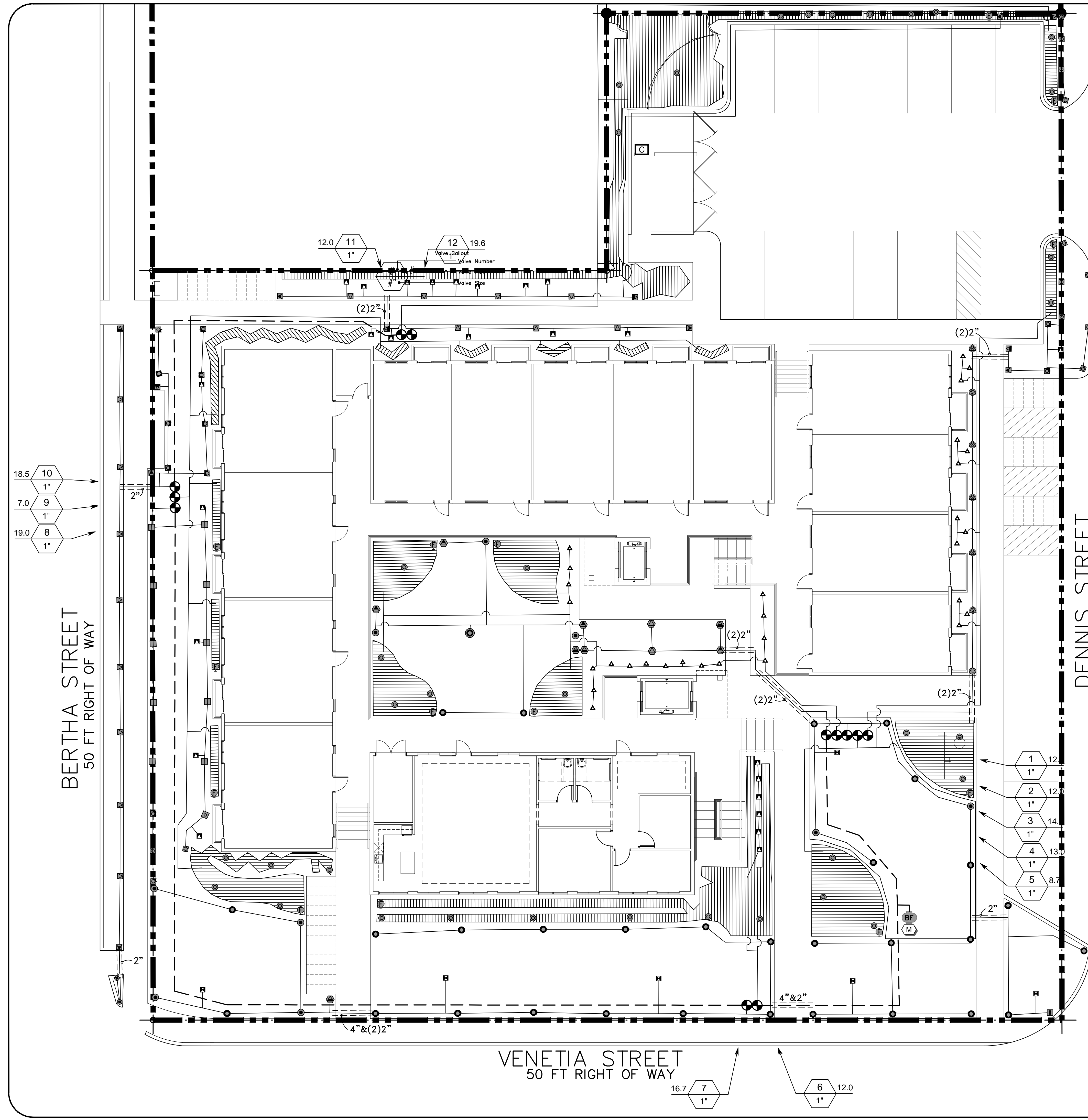

IRRIGATION_SCHEDULE

SYMBOL	MANUFACTURER/MODEL	QTY	ARC	PSI	GPM	RADIUS	PRECIP.
■	Rain Bird 180G-PRS 15 Strp Series	6	LCS	30	0.49	4x15'	1.58"/hr
■	Rain Bird 180G-PRS 15 Strp Series	6	RCS	30	0.49	4x15'	1.58"/hr
■	Rain Bird 180G-PRS 15 Strp Series	15	SST	30	1.21	4x30'	1.58"/hr
◆	Rain Bird 180G-PRS 8 Series MPR	5	180	30	0.52	8'	1.58"/hr
◆	Rain Bird 180G-PRS 8 Series MPR	2	90	30	0.26	8'	1.58"/hr
◆	Rain Bird 180G-PRS 8 Series MPR	1	120	30	0.53	8'	1.58"/hr
◆	Rain Bird 180G-PRS 10 Series MPR	6	180	30	0.79	10'	1.58"/hr
◆	Rain Bird 180G-PRS 10 Series MPR	5	90	30	0.39	10'	1.58"/hr
■	Rain Bird 180G-PRS 12 Series MPR	10	180	30	1.30	12'	1.58"/hr
●	Rain Bird 180G-PRS 6 Series VAN	2	Adj	30	6'	1.58"/hr	
■	Rain Bird 180G-PRS 8 Series VAN	4	Adj	30	8'	1.58"/hr	
■	Rain Bird 180G-PRS 10 Series VAN	1	Adj	30	10'	1.58"/hr	
■	Rain Bird 180G-PRS 12 Series VAN	1	Adj	30	12'	1.58"/hr	
▲	Rain Bird 1812-PRS 15 Strp Series	1	LCS	30	0.49	4x15'	1.58"/hr
▲	Rain Bird 1812-PRS 15 Strp Series	1	RCS	30	0.49	4x15'	1.58"/hr
▲	Rain Bird 1812-PRS 15 Strp Series	5	SST	30	1.21	4x30'	1.58"/hr
●	Rain Bird 180G with RVAN 18	1	360	45	18'	.55"/hr	
●	Rain Bird 180G with RVAN 18	30	Adj	45	18'	.55"/hr	
■	Rain Bird 180G with R-VAN 14	1	Adj	45	14'	.55"/hr	
●	Rain Bird 180G with R-VAN-1724	9	Adj	45	24'	.55"/hr	
▲	Rain Bird 180G with R-VAN Strp	4	LCS	40	0.44	5x15'	.55"/hr
▲	Rain Bird 180G with R-VAN Strp	4	RCS	40	0.44	5x15'	.55"/hr
▲	Rain Bird 180G with R-VAN Strp	2	RCS	40	0.44	5x15'	.55"/hr
■	Two Rain Bird PCT-07	4x2	360	30	2x.07	1'	NA
▲	Rain Bird PCT-07	25	360	30	.07	1'	NA
■	Two Rain Bird 1401 bubbler	32x2	360	30	2x.25	1'	NA

SYMBOL	MANUFACTURER/MODEL/DESCRIPTION	QTY	PRECIP.
●	Rain Bird 1812 with GPH Irrigation Products GDFN	14	
●	Two Rain Bird PC-10 Single Outlet	31x2	NA
■	Area to Receive Dripline Rain Bird XFD-09-12 (1G) XFD On-Surface Pressure Compensating Landscape Dripline. 0.2GPH emitters at 12.0' O.C. Dripline laterals spaced at 16.0' apart, with emitters offset for triangular pattern. UV Resistant. Install dripline on both sides of plant material.	2,600 s.f.	1.1"/hr

SYMBOL	MANUFACTURER/MODEL/DESCRIPTION	QTY
●	Rain Bird 100HV in 10" valve box. Install a 1" PVC ball valve and Rain Bird PRB-100 in a jumbo valve box.	12
BF	Wilkins 975XL 1" Backflow Preventer	1
C	Rain Bird ESP 13Me 1.3 Station Controller	1
S	Rain Bird R5D-BEx Rain Sensor	1
M	Water Meter	1
—	Irrigation Lateral Line: PVC Class 160	2,600 l.f.
—	Irrigation Mainline: PVC 1-1/2" Class 200 SDR 21	420 l.f.
—	Pipe Sleeve: PVC Schedule 40	
—	Extend sleeves 18 inches beyond edges of paving or construction.	

IRRIGATION CONTRACTOR SHALL BE RESPONSIBLE FOR THEIR OWN TAKE OFF

WATERING SCHEDULE

ZONE	GPM	WATER USE	PRECIP. RATE	MAR (2ND SUNDAY) - NOV (1ST SUNDAY)		NOV (1ST SUNDAY) - MAR (2ND SUNDAY)	
				DAYS	MINUTES	DAYS	MINUTES
1	10.0	MEDIUM	1.58"/hr	TUES / F	- 28 MIN	TUES	- 28 MIN
2	15.0	LOW	1.1"/hr	TUES / F	- 40 MIN	TUES	- 40 MIN
3	6.0	MEDIUM	.55"/hr	TUES / F	- 60 MIN	TUES	- 60 MIN
4	19.6	LOW	1.1"/hr	TUES / F	- 40 MIN	TUES	- 40 MIN
5	14.0	MEDIUM	.55"/hr	TUES / F	- 60 MIN	TUES	- 60 MIN
6	15.0	LOW	1.1"/hr	TUES / F	- 40 MIN	TUES	- 40 MIN
7	6.0	MEDIUM	.55"/hr	TUES / F	- 60 MIN	TUES	- 60 MIN
8	14.0	MEDIUM	1.58"/hr	TUES / F	- 28 MIN	TUES	- 28 MIN
9	19.4	LOW	1.1"/hr	TUES / F	- 40 MIN	TUES	- 40 MIN
10	11.8	MEDIUM	1.58"/hr	TUES / F	- 28 MIN	TUES	- 28 MIN
11	14.0	LOW	1.1"/hr	TUES / F	- 40 MIN	TUES	- 40 MIN
12	10.8	MEDIUM	1.58"/hr	TUES / F	- 28 MIN	TUES	- 28 MIN

3,200 SQ. FEET LOW WATER USE IRRIGATED SHRUBS
8,700 SQ. FEET MEDIUM USE IRRIGATED TURF
NO WATERING TO TAKE PLACE BETWEEN THE HOURS OF 10:00AM - 4:00PM

Crawford Irrigation Design, Inc.
IRRIGATION DESIGN AND CONSULTATION SERVICES
Edgewater, Florida
Tel: (386) 424-0027
EMAIL: cid@atlantic.net

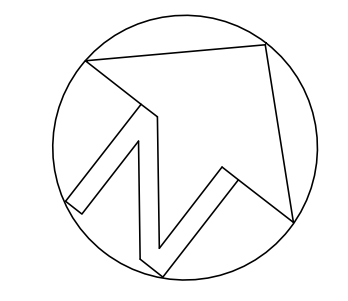

JANET O. WHITMILL, R.L.A., INC.
LANDSCAPE ARCHITECTURE * PLANNING
P.O. BOX 5212, JACKSONVILLE, FL 32247 (904) 398-7688

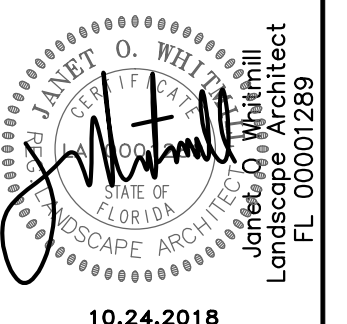

MARTY'S PLACE
NEW DEVELOPMENT
JACKSONVILLE, FLORIDA

IRRIGATION PLAN

05.21.18

© JANET O. WHITMILL, R.L.A., INC.
Copyright, Janet O. Whitmill, R.L.A., Inc.
All rights reserved. No part of this work may be used, reproduced, distributed, displayed or otherwise communicated in any form or by any means without the prior written consent of Janet O. Whitmill.

NO.	DATE	DESCRIPTION
5	10/24/18	100% CONSTRUCTION DOCUMENTS
4	09/24/18	FINAL COMMISSION COMMENTS
3	08/31/18	TREE COMMISSION COORDINATION
2	07/25/18	LANDSCAPE COORDINATION
1	07/19/18	ARBORIST ASSESSMENT

JOB NO. 23318

DRAWN: DHM

CHECKED: JOW

SCALE: 1:10

IR-1
DRAWING NO.

1.0 GENERAL

- 1.1 SUMMARY:** Includes but not limited to:
 A. Furnishing and installing sprinkler system as described in Contract Documents complete with accessories necessary for proper functioning.
- 1.2 SYSTEM DESCRIPTION:**
 A. Design Requirements:
 1. Layout of Irrigation Heads:
 a. Location of heads shown on Drawings is approximate. Actual placement may vary slightly as is required to achieve full, even coverage without spraying onto buildings, sidewalks, fences, etc.
- 1.3 QUALITY ASSURANCE:**
 A. Regulatory Requirements:
 1. Work and materials shall be in accordance with latest rules and regulations, and other applicable state or local laws. Nothing in Contract Documents is to be construed to permit work not conforming to these codes.
 B. Pre-Installation Conference:
 1. Meet with Owner and Landscape Architect to discuss and clarify all aspects of job requirements prior to commencing work of this Section.
 C. System Adjustments:
 1. Minor adjustments in system will be permitted to avoid existing fixed obstructions.
 2. Mainline, laterals, and valves are shown for clarity purposes only. All irrigation equipment to be with landscape area. Mainline, laterals and valves to be installed as far away from existing and new specimen trees as possible.
 D. 1. Documentation and submittal of actual water supply performance prior to commencing installation.
- 1.4 SUBMITTALS:**
 A. Record Drawings:
 1. Prepare an accurate as-built drawing as installation proceeds to be submitted prior to final inspection. Drawing shall include:
 a. Detail and dimension changes made during construction.
 b. Significant details and dimensions not shown in original Bidding Documents and relevant shop drawings.
 2. Maintain, at job site, one copy of Contract Documents (as defined in General Conditions) and clearly mark each document "PROJECT RECORD COPY" and maintain in good condition for use of the Landscape Architect and Owner.
 3. As-built drawing shall be clearly drawn.
 4. Submit product literature for all sprinklers, valves, pipe, wire, wire connectors and controller.
 5. Final payment for system will not be authorized until accurate and complete submittals are delivered to the Landscape Architect.
 B. Instruction Manual:
 1. Provide instruction manual which lists complete instructions for system operation and maintenance.
- 1.5 PRODUCT STORAGE:**
 A. During construction and storage, protect materials from damage and prolonged exposure to sunlight.
- 1.6 WARRANTY:**
 A. Standard one (1) year warranty stipulated in General Conditions shall include:
 1. Completed system including parts and labor.
 2. Filling and repairing depressions and replacing plantings due to settlement of irrigation trenches for one (1) year following final acceptance.
 3. System adjustment to supply proper coverage to areas to receive water.
- 1.7 MAINTENANCE:**
 A. Extra Materials:
 1. In addition to installed system, furnish Owner with the following items at close-out:
 a. Two sprinkler head bodies of each size and type.
 b. Two nozzles for each size and type.
 c. Two adjusting keys for each sprinkler head cover type.

2.0 PRODUCTS:

- 2.1 PIPE, PIPE FITTINGS, AND CONNECTIONS:**
 A. Pipe shall be continuously and permanently marked with Manufacturer's name, size, schedule, type, and working pressure.
 B. Pipe:
 1. Pressure Lines: as indicated on plans.
 2. Lateral Lines: as indicated on plans.
 3. Risers: sch. 80 PVC, gray
 C. Fittings:
 1. Schedule 40 PVC.
 D. Steeving:
 1. Schedule 40 PVC.
- 2.2 SPRINKLER HEADS:**
 A. Conform to requirements shown on Drawings as to type, radius of throw, pressure, and discharge.
- 2.3 AUTOMATIC SPRINKLER SYSTEM:**
 A. Control valves shall be of size and type indicated on Drawings.
 B. Control wire shall be UL listed, color coded copper conductor direct burial size 14. Use 3M-DBY waterproof wire connectors at splices and locate all splices within valve boxes. Use white or gray color for common wire and other colors for all other wire.
- 2.4 VALVES:**
 A. Electric Valves:
 1. Make and model shown on Drawings.
 B. Automatic Controller:
 1. Make and model shown on Drawings.
- 2.5 VALVE ACCESSORIES:**
 A. Valve Boxes:
 1. Ametek or Brooks heavy duty valve box with locking lid or Landscape Architect approved equal.
 2. Do not install more than one (1) valve in a single box.
 3. Valve boxes shall be large enough for easy removal or maintenance of valves.

3.0 EXECUTION:

- 3.1 PREPARATION:**
 A. Protection:
 1. Work of others damaged by this Section during course of its work shall be replaced or repaired by original installer at this Section's expense.
- 3.2 INSTALLATION:**
 A. Trenching and Backfilling:
 1. Over-excavate trenches by two (2") inches and bring back to indicated depth by filling with fine, rock-free soil or sand.
 2. Cover pipe both top and sides with two (2") inches of material specified in paragraph above. In no case shall there be less than two (2") inches of rock-free soil or sand surrounding pipe.

- B. Installation of Plastic Pipe:**
 1. Install plastic pipe in a manner to provide for expansion and contraction as recommended by Manufacturer.
 2. Unless otherwise indicated on Drawings, install main lines with a minimum cover of eighteen (18") inches based on finish grade. Install lateral lines with a minimum cover of twelve (12") inches based on finish grade.
 3. Locate no sprinkler head closer than twelve (12") inches from building foundation. Heads immediately adjacent to mowing strips, walks or curbs shall be one (1") inch below top of mowing strip, walk or curb and have a minimum of one (1") inch clearance between head and mowing strip, walk or curb.
 4. Drawings show arrangement of piping. Should local conditions necessitate rearrangement, obtain approval of Landscape Architect prior to proceeding with work.
 5. Cut plastic pipe square. Remove burrs at cut ends prior to installation so unobstructed flow will result.
 6. Make solvent weld joints in the following manner:
 a. Clean mating pipe and fitting with clean, dry cloth and apply one (1) coat of P-70 primer to each.
 b. Apply uniform coat of 711 solvent to outside of pipe.
 c. Apply solvent to fitting in similar manner.
 d. Reapply a light coat of solvent to pipe and quickly insert into fitting.
 e. Give pipe or fitting a quarter turn to insure even distribution of solvent and make sure pipe is inserted to full depth of fitting socket.
 f. Hold in position for fifteen (15) seconds minimum or long enough to secure joint.
 g. Wipe off solvent appearing on outer shoulder of fitting.
 h. Do not use an excessive amount of solvent thereby causing an obstruction to form on the inside of pipe.
 i. Allow joints to set at least 24 hours before applying pressure to PVC pipe.
 7. Tape threaded connection with teflon tape.
- C. Control Valves and Controller:**
 1. Install controller, control wires, and valves in accordance with Manufacturer's recommendations and according to applicable electrical code.
 2. Install valves in plastic boxes with reinforced heavy duty plastic covers. Locate valve box tops at finish grade.
 3. Install remote control valves in valve boxes positioned over valve so all parts of valve can be reached for service. Set cover of valve box even with finish grade.
 4. Install all valve boxes over nine (9") inches of gravel for drainage.
- D. Sprinkler Heads:**
 1. Prior to the installation of sprinkler heads, open control valves and use full head of water to flush out system.
 2. Set sprinkler heads perpendicular to finish grade.
 3. Set lawn sprinkler heads adjacent to existing walks, curbs, and other paved areas to grade.
- E. Dripline:**
 1. Stake dripline every eight feet along dripline laterals.
- 3.3 ADJUSTMENT AND CLEANING:**
 A. Adjust heads to proper grade when turf is sufficiently established to allow walking on it without appreciable harm. Such lowering or raising of heads shall be part of the original contract with no additional charge to the Owner.
 B. Adjust sprinkler heads for proper distribution and trim to ensure spray does not fall on building.
 C. Adjust watering time of valves to provide proper amounts of water to all plants.
- 3.4 DEMONSTRATION:**
 A. After system is installed and approved, instruct Owners Representative in complete operation and maintenance.

END OF SECTION

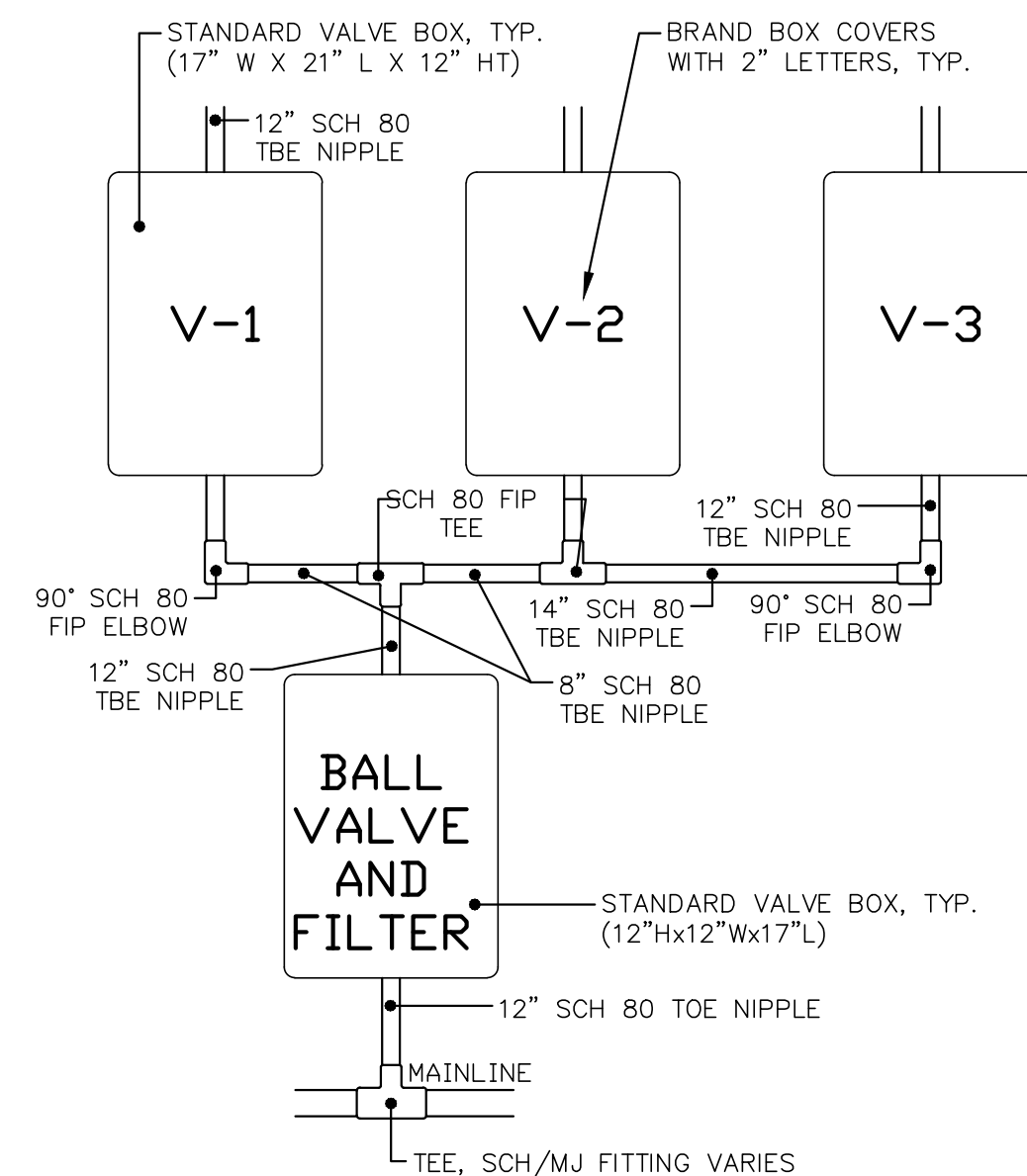

VALVE BOX LAYOUT
 N.T.S.

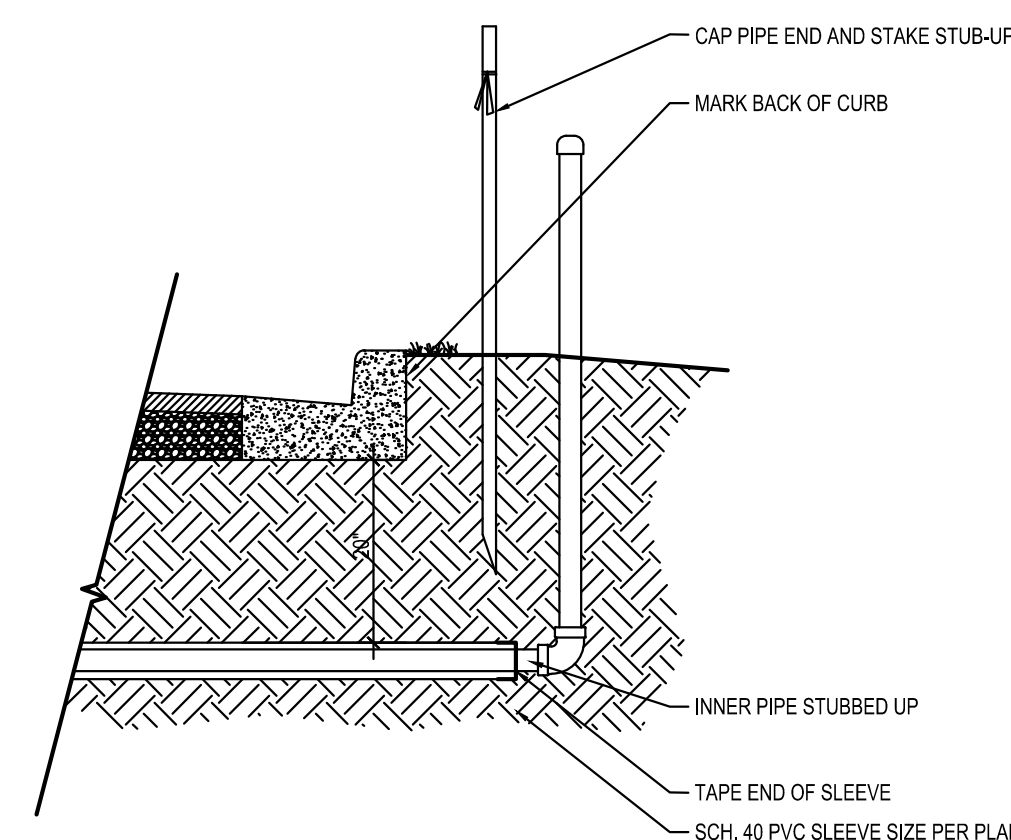

SLEEVING ROUGH-IN DETAIL
 SCALE: NTS

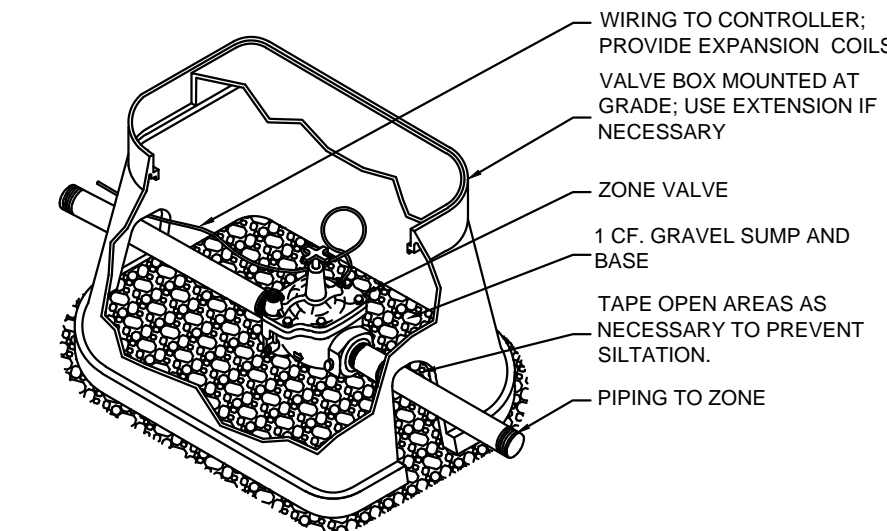

INSTALL TOP OF VALVE A MAXIMUM OF 15" FROM FINISHED GRADE.

ZONE VALVE INSTALLATION DETAIL
 SCALE: NTS

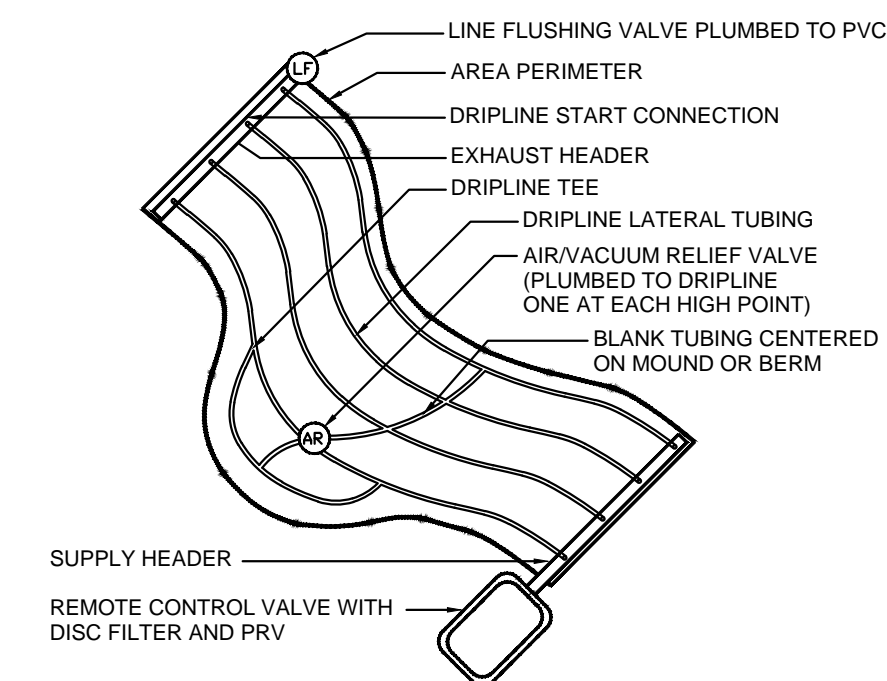

IRREGULAR AREA DIPLINE LAYOUT

JANET O. WHITMILL, R.L.A., INC.
 LANDSCAPE ARCHITECTURE * PLANNING
 P.O. BOX 5212, JACKSONVILLE, FL 32247 (904) 398-7688



MARTY'S PLACE
NEW DEVELOPMENT
JACKSONVILLE, FLORIDA

IRRIGATION PLAN
05.21.18

© JANET O. WHITMILL, R.L.A., INC. Copyright, Janet O. Whitmill, R.L.A. All rights reserved. No part of this work may be used, reproduced, distributed, displayed or otherwise communicated in any form or by any means without the prior written consent of Janet O. Whitmill.

NO.	DATE	REV.	DESCRIPTION
5	10.24.18		100% CONSTRUCTION DOCUMENTS
4	09.24.18		FINAL COMMISSION COMMENTS
3	08.31.18		TREE COMMISSION COMMENTS
2	07.26.18		LANDSCAPE COORDINATION
1	07.19.18		ARBORIST ASSESSMENT

JOB NO. 23318
DRAWN: DHM
CHECKED: JOW
SCALE: 1:10
IR-2
DRAWING NO.

BERTHA STREET
50 FT RIGHT OF WAY

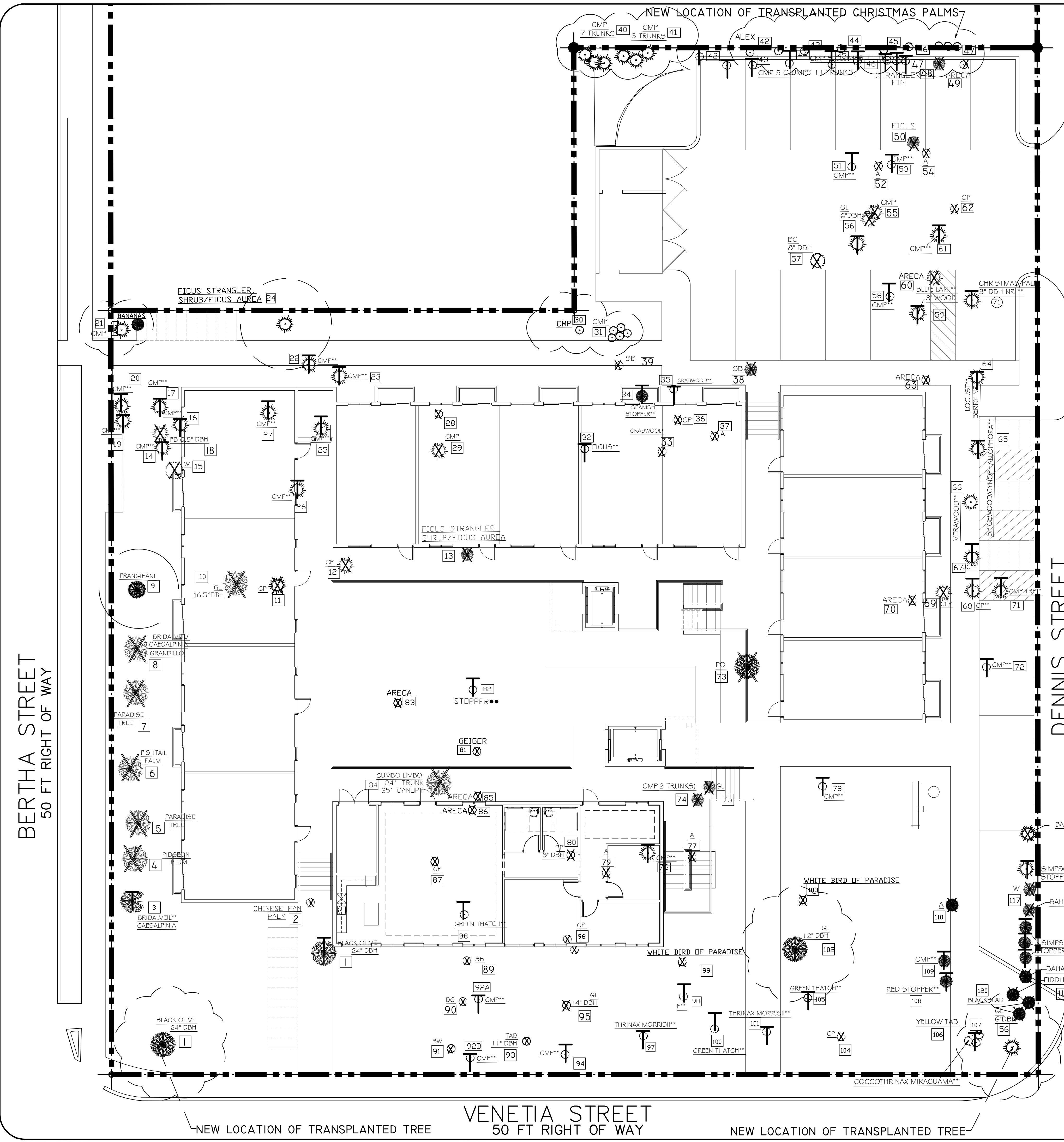

LEGEND

- TREE TO BE REMOVED
 - **TREE TO BE TRANSPLANTED
 - TREE TO BE PRESERVED WITH BARRICADE
- **ALL TRANSPLANTS SHALL BE OFFSITE.

LEGEND

ABBREVIATION	TREES	PP	PIGEON PLUM
GL	GUMBO LIMBO	A	ARECA
BO	BLACK OLIVE	W	WASHINGTONIAN
PD	POINCIANA	KT	KEYS THATCH
SS	SPANISH STOPPER	TP	TRIANGLE PALM
CP	COCONUT PALM	TAB	TABEUBIA
CMP	CHRISTMAS PALM	E	FRANGIPANI
BC	BARBADOS CHERRY	BC	BAY CEDAR
BW	BUTTONWOOD	TRP	TRAVELERS PALM
FB	FIGUS BENJAMIN	SB	SILVER BUTTWOOD
FC	FIGUS CITROFOLIA		
B	BISMARK PALM		

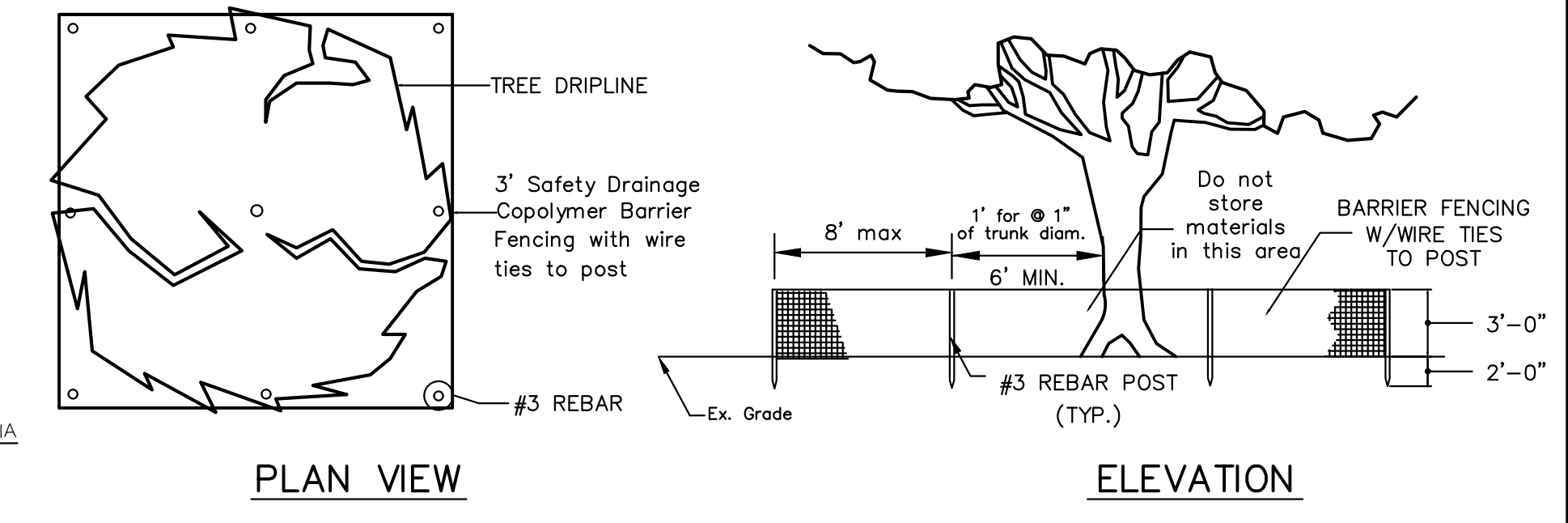

PLAN VIEW

ELEVATION

TREE PROTECTION FENCING DETAIL
NOT TO SCALE

THE TREE PROTECTION BARRICADE SHALL BE AT LEAST THREE (3) FEET HIGH. THE BARRIER SHALL CONSIST OF EITHER WOOD FENCE WITH 2X4 POSTS PLACED A MAXIMUM EIGHT (8) FEET APART, WITH A 2X4 MINIMUM TOPRAIL, OR A TEMPORARY WIRE MESH FENCE, OR OTHER SIMILAR BARRIER WHICH WILL LIMIT ACCESS TO PROTECTED AREA.

THE BARRICADE SHALL BE AT LEAST TO THE DRIPLINE OF THE TREE.

TREE BARRICADE APPROVAL: OBTAIN CITY APPROVAL OF TREE BARRICADES BEFORE BEGINNING CLEARING OPERATIONS OR ANY SITE DEVELOPMENT.

JANET O. WHITMILL, R.L.A., INC.
LANDSCAPE ARCHITECTURE * PLANNING
P.O. BOX 5212, JACKSONVILLE, FL 32247 (904) 398-7688

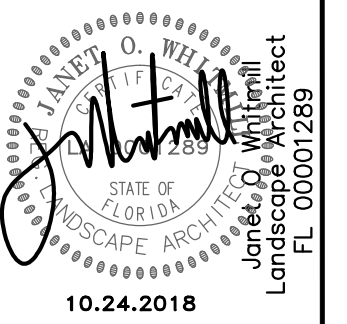

MARTY'S PLACE
NEW DEVELOPMENT
JACKSONVILLE, FLORIDA

TREE MITIGATION PLAN

05.21.18

© JANET O. WHITMILL, R.L.A., INC.
Copyright, Janet O. Whitmill, R.L.A., Inc.
All rights reserved. No part of this work may be used, reproduced, distributed, displayed or otherwise communicated in any form or by any means without the prior written consent of Janet O. Whitmill.

NO.	DATE	DESCRIPTION
5	10/24/18	100% CONSTRUCTION DOCUMENTS
4	09/24/18	FINAL COMMISSION COMMENTS
3	08/31/18	TREE COMMISSION COMMENTS
2	07/26/18	LANDSCAPE COORDINATION
1	07/19/18	ARBORIST ASSESSMENT

JOB NO. 23318

DRAWN: DHM

CHECKED: JOW

SCALE: 1:10

TM-1
DRAWING NO.

Marty's Place Plant Inventory List- 1512 Dennis, 1515 Bertha

1. Black Olive/Bucida buceras -Transplant Fair, 24 1/4", codominant
2. Chinese Fan Palm/Livistona chinensis -Remove Poor, less than 4'
3. Bridalveil/Caesalpinia grandillo -Transplant, Poor, 4", partially uprooted
4. Pigeon Plum/Coccoloba diversifolia -Remove Poor, 2 3/4", partially uprooted, thin canopy, 45' angle lean
5. Paradise/Simaruba glauca -Remove Poor, 6", thinning canopy, circling roots, one-sided, tip dieback
6. Fishtail Palm/Caryota mitis -Remove
7. Paradise/Simaruba glauca -Remove Poor, 6 1/2", tip and branch dieback, lead and canopy top dead
8. Bridalveil/Caesalpinia grandillo -Remove, Poor, codominant with included bark
9. Frangipani 'Key West'/Plumeria -Retain/Protect 4 1/2" Fair-Good
10. Gumbo Limbo/Bursea simaruba -Remove Poor, 16 1/2", low branching codominant with included bark
11. Coconut (2)/Cocos nucifera -Remove 18'-20' wood
12. Coconut/Cocos nucifera -Remove 23'-25' wood
13. Ficus 'Strangler' shrub/Ficus aurea -Remove, topped for screening hedge
14. Christmas Palm (3)/Adonidia merrillii -Transplant, 8'-9' wood
15. Washington Palm/Washingtonia robusta -Remove, 25'-30' wood
16. Christmas Palm/Adonidia merrillii -Transplant, 18'-20' wood
17. Christmas Palm/Adonidia merrillii -Transplant, 12'-15' wood
18. Weeping Fig/ Ficus benjamina -Remove Poor, 6 1/2"
19. Christmas Palm/Adonidia merrillii -Transplant, 10'-12' wood
20. Christmas Palm/Adonidia merrillii -Transplant, 10'-12' wood
21. Christmas Palm/Adonidia merrillii -Retain, 10'-12' wood
22. Christmas Palm (2)/Adonidia merrillii -Transplant, 18'-25' wood
23. Christmas Palm/Adonidia merrillii -Transplant, 10'-13' wood
24. Ficus/Ficus aurea -Retain/Protect 4 1/2 - 5' diameter, fair, storm and utility pruning damage
25. Christmas Palm/Adonidia merrillii -Transplant, 18'-20' wood
26. Christmas Palm (2)/Adonidia merrillii -Transplant, 18'-20' wood
27. Christmas Palm/Adonidia merrillii -Transplant, 18'-20' wood
28. Spanish Stopper/Eugenia foetida -Remove Fair, 3 stems total 1", half root system under building
29. Christmas Palm/Adonidia merrillii -Remove 10'-12' wood, trunk damage-mechanical
30. Christmas Palm/Adonidia merrillii -Retain, 18'-20' wood
31. Christmas Palm (4)/Adonidia merrillii -Retain, 12'-20' wood
32. Ficus 'Shortleaf'/Ficus citrifolia -Transplant Fair, 9 1/2"
33. Crabwood/Gymnanthes lucida -Remove Poor, 1 3/4", storm damage, shrub
34. Spanish Stopper/Eugenia foetida -Transplant Fair, 1"
35. Crabwood/Gymnanthes lucida -Transplant Good, standard 1 1/2"
36. Coconut Palm/Cocos nucifera -Remove 15'-18' wood

104. Coconut Palm/Cocos nucifera -Remove 25'-30' wood
105. Green Thatch/Thrinax radiata -Transplant Good, 8' over-all
106. Yellow Tab-Silver Trumpet/Tabebuia caraiba -Remove Poor, 12 1/2", storm damage with decay, very few leaves
107. Coccothrinax miraguama -Transplant Good, 3'-6' of wood, triple
108. Red Stopper/Eugenia rhombea -Transplant Fair, 1"
109. Christmas Palm/Adonidia merrillii -Transplant 12'-15' wood
110. Alexander Palm/Ptychosperma elegans -Remove 4'-10' wood
111. Fiddlewood/Citharexylum spinosum -Remove Poor, 3 3/4", storm damage, very few leaves, mostly dead
112. Bahama Tab/Tabebuia bahamensis -Remove, Poor, 2 1/2", tip and branch die-back
113. Simpson Stopper/Myrcianthes fragrans -Transplant Fair, 1 1/2"
114. Simpson Stopper/Myrcianthes fragrans -Transplant Fair, 1"
115. Simpson Stopper/Myrcianthes fragrans -Transplant Fair, 1"
116. Bahama Tab/Tabebuia bahamensis -Remove, Fair, 2 3/4", tip die-back, one sided
117. Washington Palm/Washingtonia robusta -Remove 5' wood
118. Simpson Stopper/Myrcianthes fragrans -Transplant, Poor, 3/4", topped
119. Bahama Tab/Tabebuia bahamensis -Remove, Poor, 3 1/4", tip die-back, major mechanical damage
120. Black Bead (2)/Pithecellobium keyense -Remove (1)Poor, hedged, Transplant (1)
121. Washington Palm (2)/Washingtonia robusta -Remove Poor, 1 1/2", multiple stem, 12'-15' wood
122. Washington Palm (3)/Washingtonia robusta -Remove 2'-18' wood
123. Washington Palm/Washingtonia robusta -Remove 10'-13' wood/10'-12' wood
124. Black Bead/Pithecellobium keyense -Remove Poor, 4", hedged, growing through fence

37. Areca Palm/Dypsis lutescens -Remove
38. Silver buttonwood/Conocarpus erectus sericeus -Remove Poor, 1 1/2", maintained as hedge
39. Silver buttonwood/Conocarpus erectus sericeus -Remove Poor, 8 3/4", maintained as hedge, half of root system under building
40. Christmas Palm (5)/Adonidia merrillii -Retain, 8'-20' wood
41. Christmas Palm (3)/Adonidia merrillii -Retain, 6'-18' wood
42. Areca Palm/Dypsis lutescens -Transplant
43. Alexander Palm/Ptychosperma elegans -Transplant, 18'-20' wood
44. Christmas Palm (2)/Adonidia merrillii -Transplant 15'18' wood
45. Christmas Palm (3)/Adonidia merrillii -Transplant, 10'-18' wood
46. Christmas Palm (2)/Adonidia merrillii -Transplant, 16'-20' wood
47. Christmas Palm (3)/Adonidia merrillii -Retain, 16'-20' wood
48. Ficus 'Strangler' shrub/Ficus aurea -Remove Poor, 3 stems total 3", stumped, regrowth
49. Areca Palm/Dypsis lutescens -Remove
50. Ficus 'Strangler' shrub/Ficus aurea -Remove Poor, maintained as hedge, stumped, regrowth
51. Christmas Palm/Adonidia merrillii -Transplant, 10'-12' wood
52. Areca/Dypsis lutescens -Remove
53. Christmas Palm/Adonidia merrillii -Transplant, 15'-18' wood
54. Areca Palm/Dypsis lutescens -Remove
55. Christmas Palm (2)/Adonidia merrillii -Remove, 15'-18' wood, in same root system with Gumbo Limbo-# 56.
56. Gumbo Limbo/Bursea simaruba -Transplant, Fair, 10 1/4", codominant, over lifted, 35-40% root system compromised by fish pond and double Christmas palms-number 55. Tree will be incorporated by converting a parking space in parking lot into a planter
57. Barbados Cherry/Malpighia glabra -Remove Poor, 7 1/2", dieback, multi trunked with trunk damage
58. Christmas Palm/Adonidia merrillii -Transplant, 5 1/2' wood
59. Blue Latania/Latania loddigesii -Transplant Good, 3' wood
60. Areca/Dypsis lutescens -Remove
61. Christmas Palm/Adonidia merrillii -Transplant, 15'-18' wood
62. Coconut Palm/Cocos nucifera -Remove 15'-18' wood
63. Areca Palm/Dypsis lutescens -Remove
64. Locustberry/Byrsonima lucida -Transplant Fair, 2 1/2"
65. Spicewood/Calyptanthes pallens -Transplant Fair, total stems 4"
66. Verawood/Bulnesia arborea -Transplant Fair, 3"
67. Jamaica Caper/Capparis cynophallophora -Transplant, 2' seedling
68. Coconut Palm/Cocos nucifera -Transplant, no wood
69. Chinese Fan Palm (3)/Livistona chinensis -Remove triple 3' wood
70. Areca Palm/Dypsis lutescens -Remove
71. Christmas Palm (3)/Adonidia merrillii -Transplant, outside fence 18'-25' wood
72. Christmas Palm/Adonidia merrillii -Transplant, 8' wood

73. Poinciana/Delonix regia -Remove Poor, 14 3/4", large west codominant removed-with wound wood closure and decay evident, included bark evident east side of tree, canopy storm damaged with tip dieback, decay and flushing, decay at old pruning cuts, 30-40% of root system compromised by in-ground cistern. Support roots on north side of tree are non-existent around cistern
74. Christmas Palm (2)/Adonidia merrillii -Remove, 15'-20' wood, shared root system with #75
75. Gumbo Limbo/Bursea simaruba -Remove, Poor, dog-leg at 5', shared root system with #74
76. Christmas Palm (3)/Adonidia merrillii -Transplant, 12'-15' wood
77. Areca Palm/Dypsis lutescens -Remove
78. Christmas Palm (2)/Adonidia merrillii -Transplant, 10'-12' wood
79. Areca Palm/Dypsis lutescens -Remove
80. Triangle Palm/Dypsis decaryi -Remove 5' wood
81. Orange Geiger/Cordia sebestena -Remove Poor, 1" re-sprout
82. Spanish Stopper/Eugenia foetida -Transplant, Good 3"
83. Areca/Dypsis lutescens -Remove
84. Gumbo Limbo/Bursea simaruba -Remove, Poor, 20 3/4", codominant with multiple areas of included bark, decay evident, active subterranean termites, damage throughout tree including main area of branch unions
85. Areca Palm/Dypsis lutescens -Remove
86. Areca Palm/Dypsis lutescens -Remove
87. Coconut Palm/Cocos nucifera -Remove 18'-20' wood
88. Green Thatch Palm/Thrinax radiata -Transplant Good, 5 1/2' over all height
89. Silver buttonwood/Conocarpus erectus sericeus -Remove Poor, 5", maintained as hedge
90. Bay Cedar/Suriana maritima -Remove, Poor, 1", topped, hedged
91. Green Buttonwood/Conocarpus erectus -Remove, Poor, 5 3/4", heavy canopy, one-sided, leaning west 45' angle,
92. A. Christmas Palm/Adonidia merrillii -Transplant, 8' wood
B. Christmas Palm (3)/Adonidia merrillii -Transplant, 3'-10' wood
93. Yellow Tab-Silver Trumpet/Tabebuia caraiba -Remove, Poor, 12 1/2", main trunk dog-leg west 45' angle, tip dieback
94. Christmas Palm/Adonidia merrillii -Transplant, 8'-10' wood, site of new Gumbo Limbo
95. Gumbo Limbo/Bursea simaruba -Remove, Poor, 4 multi-trunk total 12", codominant at 1' above grade
96. Coconut Palm (2)/Cocos nucifera -Remove 20'-25' wood
97. Thrinax morrisii/Leucothrinax morrisii -Transplant Good, 6' over-all
98. Frangipani/Plumeria -Transplant Poor, 4", leaning west 45' angle
99. White Bird of Paradise/Strelitzia nicolai -Remove
100. Green Thatch/Thrinax radiata -Transplant Good, 8' over-all
101. Thrinax morrisii/Leucothrinax morrisii -Transplant Good, 6' over-all
102. Gumbo Limbo/Bursea simaruba -Retain, Fair, 12 1/2", included bark, over-lifted, limbs pruned away from structures. Integrated into planter
103. White Bird of Paradise/Strelitzia nicolai -Remove

LEGEND

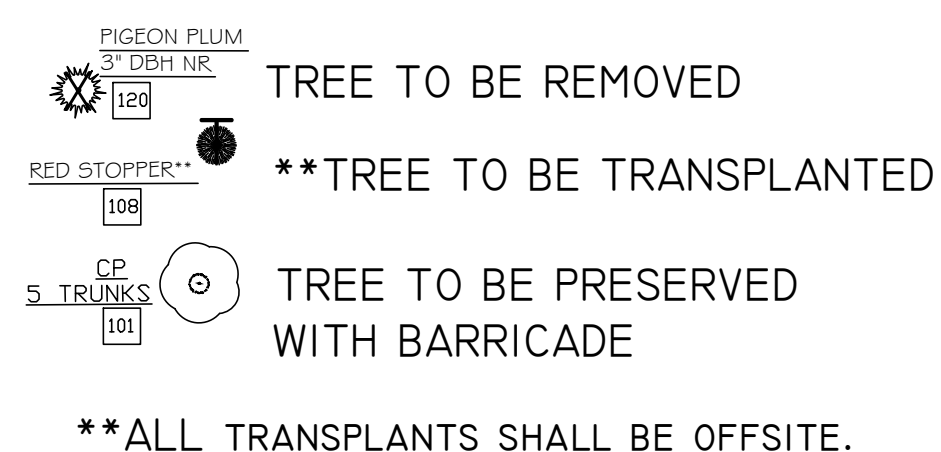

LEGEND			
ABBREVIATION	TREES		
GL	GUMBO LIMBO	PP	PIGEON PLUM
BO	BLACK OLIVE	A	ARECA
PO	POINCIANA	W	WASHINGTONIAN
SS	SPANISH STOPPER	KT	KEYS THATCH
CP	COCONUT PALM	TP	TRIANGLE PALM
CMP	CHRISTMAS PALM	TAB	TABEBUIA
BC	BARBADOS CHERRY	E	FRANGIPANI
BW	BUTTONWOOD	BC	BAY CEDAR
EB	FIGUS BENJAMIN	TRP	TRAVELERS PALM
FC	FIGUS CITRIFOLIA	SB	SILVER BUTTONWOOD
B	BISMARCK PALM		

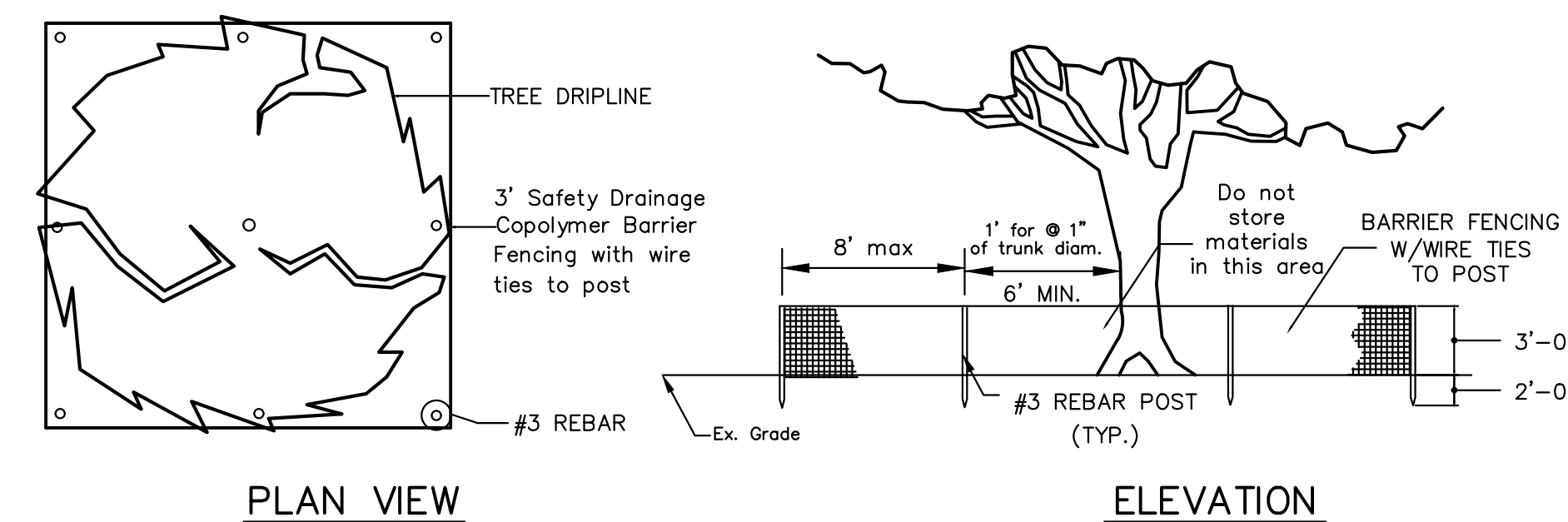

TREE PROTECTION FENCING DETAIL

THE TREE PROTECTION BARRICADE SHALL BE AT LEAST THREE (3) FEET HIGH. THE BARRIER SHALL CONSIST OF EITHER WOOD FENCE WITH 2X4 POSTS PLACED A MAXIMUM EIGHT (8) FEET APART, WITH A 2X4 MINIMUM TOPRAIL, OR A TEMPORARY WIRE MESH FENCE, OR OTHER SIMILAR BARRIER WHICH WILL LIMIT ACCESS TO PROTECTED AREA.

THE BARRICADE SHALL BE AT LEAST TO THE DRIPLINE OF THE TREE.

TREE BARRICADE APPROVAL: OBTAIN CITY APPROVAL OF TREE BARRICADES BEFORE BEGINNING CLEARING OPERATIONS OR ANY SITE DEVELOPMENT.

JANET O. WHITMILL, R.L.A., INC.
LANDSCAPE ARCHITECTURE * PLANNING
P.O. BOX 5212, JACKSONVILLE, FL 32247 (904) 398-7688

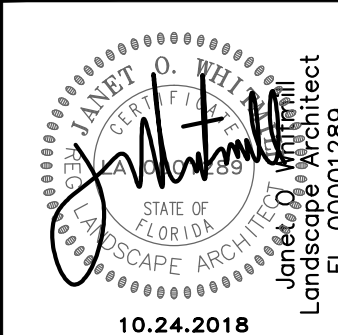

MARTY'S PLACE
NEW DEVELOPMENT
JACKSONVILLE, FLORIDA

TREE MITIGATION PLAN

05.21.18

© JANET O. WHITMILL, R.L.A., INC. Copyright, Janet O. Whitmill, R.L.A. All rights reserved. No part of this work may be used, reproduced, distributed, displayed or otherwise communicated in any form or by any means without the prior written consent of Janet O. Whitmill.

NO.	DATE	DESCRIPTION
1	07/18/18	ARBORIST ASSESSMENT
2	07/25/18	LANDSCAPE COORDINATION
3	08/11/18	TREE COMMISSION COMMENTS
4	09/24/18	FINAL COMMISSION COMMENTS
5	10/24/18	100% CONSTRUCTION DOCUMENTS

JOB NO. 23318

DRAWN: DHM

CHECKED: JOW

SCALE: 1:10

TM-2
DRAWING NO.

STAFF REPORT

DATE: October 31, 2018

RE: **1515-1525 Bertha Street & 1512 Dennis Street**
(permit application # T2018-0027 & T2018-0033)

FROM: Karen DeMaria, City of Key West Urban Forestry Manager

An application was received requesting Final Landscape Plan Approval for a major development plan to redevelopment the property. The updated plan includes;

Removal of a total of 22 trees: 4-Gumbo Limbo (#10, #75, #84, & #95), 3- Silver Buttonwood (#38, #39, and #89), 2-Yellow Tabebuia trees (#93 and #106), 2-Paradise trees (#5 and #7), 1-Bridalveil trees (#8), 1-Pigeon Plum (#4), 1-Fiddlewood tree (#111), 1-Strangler Fig (#13), 1-Spanish Stopper (#28), 1-Bay Cedar (#90), 1-Crabwood tree (#33), 1-Barbados Cherry tree (#57), 1-Royal Poinciana tree (#73), 1-Orange Geiger (#81), and 1-Green Buttonwood tree (#91).

Removal of a total of 15 palms: 3-Christmas palms (#29, #55, and #74), 4-Washingtonia palms (#15, #121, #122, and #123), 7-Coconut palms (#11, #12, #36, #62, #87, #96, #104), and 1-Alexander palm (#110).

Transplanting of a total of 9 trees offsite: 2-Spanish Stopper (#34 and #82), 1-Bridalveil (#3), 1-Shortleaf Fig (#32), 1-Crabwood (#35), 1-Locustberry (#64), 1-Spicewood (#65), 1-Frangipani (#98), and 1-Red Stopper (#108).

Transplanting of a total of 25 palms offsite: 18-Christmas palms (#16, #17, #19, #20, #22, #23, #25, #26, #27, #51, #53, #61, #71, #76, #78, #92B, #94, and #109), 4-Thatch Palms (#88, #97, #100, #101, and #105), 1-Florida Silver Thatch Palm (#107), and 1-Coconut Palms (#68).

Transplanting of a total of 2 trees and 4 palms onsite: 1-Black Olive tree (#1), 1-Gumbo Limbo (#56), 3-Christmas Palms (#44, #45, #46), and 1-Alexander Palm (#43).

Four trees are being protected and remaining in place; 1-Frangipani (#9), 1-Strangler Fig (#24), 1-Gumbo Limbo (#102). Six Christmas palms are being protected and remaining in place (#21, #30, #31, #40, #41, & #47).

The rest of the vegetation on the property not listed above is not regulated. Some of these trees and palms are being transplanted (see attached updated tree list dated 10-31-18).

Changes to the landscape plan that have been submitted for Final Landscape plan approval since approval of the Conceptual Landscape plan include transplanting of 1-Black Olive tree (#1 originally to be removed) and 1-Gumbo Limbo (#56), 1-Alexander Palm (#43), and 3-Christmas Palms (#44, #45, & #46) onsite (originally to remain in place). The Gumbo Limbo and palms must be transplanted in order for the project to have required parking onsite.

A total of 111.5 caliper inches of replacement trees are required to be planted on the property and incorporated as per the tree removal approval and incorporated into the landscape plan. An old tree removal permit exists on the property and those required replacement inches also must be included in the landscape plan. T14-7203 authorized the removal of (1) Royal Poinciana tree with the required replacement of 23 caliper inches. Therefore, a total of 134.5 caliper inches is required to be planted and incorporated into the landscape plan.

The landscape plan consists of a majority of native species or species that do well in the Key West area. The plan does include a mixture of palm species (Florida Thatch, Keys Thatch and Sabal Palms). Three Royal Poinciana trees and eight Gumbo Limbos (canopy trees) will be planted in the new landscaping. It does appear that the landscape plan incorporates all the required replacement inches.

Recommendation: Recommend approval of the Final Landscape Plan with Tree removal as submitted and presented.

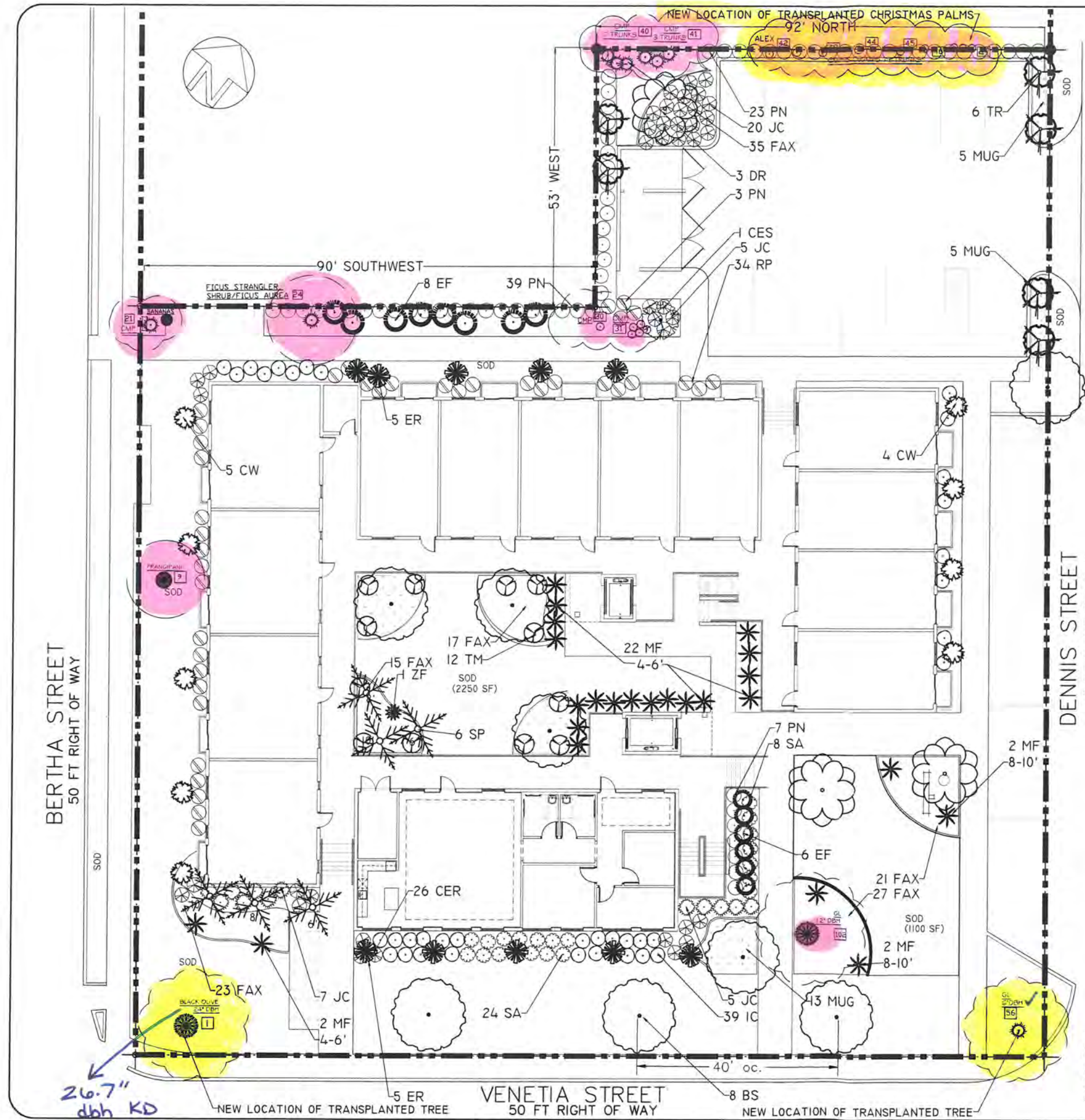

PLANT LIST

QTY	SYM	DESCRIPTION
6	TR	THRINAX RADIATA "FLORIDA THATCH"
14	EF	EUGENIA FOETIDA "SPANISH STOPPER"
12	TM	THRINAX MORRSII "KEYS THATCH"
8	BS	BURSERA SIMARUBA "GUMBO LIMBO"
1	CES	CONOCARPUS ERECTUS SERICESUS "SILVER BUTTONWOOD"
6	SP	SABAL PALMETTO "CABBAGE PALM"
3	DR	DELONIX REGIA "POINCIANA"
34	RP	RAPANEA PUNCTATA "MYRSINE"
10	ER	EUGENIA RHOMBEA "RED STOPPER"
9	CW	CANELLA WINERANA "WILD CINNAMON"
28	MF	MYRICANTHUS FRAGRANS "SIMPSON STOPPER"
72	PN	PSYCHOTRIA LIGUSTRIFOLIA "DWARF COFFEE"
26	CER	CODIAEUM "ELEANORE ROOSEVELT CROTON"
32	SA	SAVIA BAHAMENSIS "MAIDENBUSH"
39	IC	IXORA COCCINEA "IXORA SUPER KING"
37	JC	CAPPARIS CYNOPHALLOPHORA "JAMAICAN CAPER"
23	MUG	MUHLENBERGIA CAPILLARIS "MUHLY GRASS"
138	FAX	TRIPSACUM DACTYLAIDES "DWARF FAKAHATCHEE"
1	ZF	ZANTHOXYLUM FLAVUM "YELLOWHEART"

LEGEND

ABBREVIATION	TREES
GL	GUMBO LIMBO
BO	BLACK OLIVE
PO	POINCIANA
WT	WOMEN'S TONGUE
CP	COCONUT PALM
CMP	CHRISTMAS PALM
BC	BARBADOS CHERRY
BW	BUTTONWOOD
FB	FICUS BENJAMIN
EC	FICUS CITROFOLIA
B	BISMARCK PALM
PP	PIGEON PLUM
A	ARECA
W	WASHINGTONIAN
KT	KEYS THATCH
TP	TRIANGLE PALM
TAR	TABERBUJA
E	FRANGIPANI
BC	RAY CEDAR
TRP	TRAVELERS PALM
SB	SILVER BUTTONWOOD
SS	SPANISH STOPPER

TRANSPLANTED MATERIALS - TREE RELOCATION SPECIFICATIONS:

1. Locating and verifying all existing underground utilities before any trees are installed and coordinated closely with respective utility contractors involved in those certain areas.
2. If any tree should shock and die it is to be removed and replaced with like species and size, as directed by the Landscape Architect and Owner.
3. Water in trees. See Landscape Installation Specifications.
4. Providing Cypress Mulch, peat, potting soil and fertilizer on site so that proper planting is being done.
5. Guarantee that all relocated trees will survive for one year.
6. Inspect all plant material for insect/disease problem.

NOTE:
ALL WORK PERFORMED WITHIN AN EASEMENT OR A PUBLIC RIGHT-OF-WAY REQUIRES A SEPARATE PERMIT BY THE DEPT OF PUBLIC WORKS. PROVIDE A MIN. 3' CLEARANCE FROM THE EDGE OF DRIVEWAYS TO ANY SUCH STRUCTURE SUCH AS INLETS, TRANSFORMERS, POLES, ETC., IN RIGHT-OF-WAY EASEMENT.
CONTACT SURVMD AND ANY OTHER GOVERNMENTAL AGENCIES PRIOR TO WORK IN JURISDICTIONAL WETLANDS.

48 HOURS BEFORE YOU DO
CALL SUNSHINE
1-800-432-4770
IT'S THE WAY IN FLORIDA

JANET O. WHITMILL, R.L.A., INC.
LANDSCAPE ARCHITECTURE * PLANNING
P.O. BOX 9212, JACKSONVILLE, FL 32247 (904) 398-7689

Janet O. Whitmill
Landscape Architect
FL 00001289
10.24.2018

MARTY'S PLACE
NEW DEVELOPMENT
JACKSONVILLE, FLORIDA

LANDSCAPE PLAN

05.21.18

JANET O. WHITMILL, R.L.A., INC.
Copyright, Janet O. Whitmill, R.L.A., Inc. All rights reserved. No part of this work may be used, reproduced, distributed, displayed or otherwise communicated in any form or by any means without the prior written consent of Janet O. Whitmill, R.L.A., Inc.

NO.	DATE	DESCRIPTION
1	05/21/18	LANDSCAPE COORDINATION
2	05/21/18	LANDSCAPE COORDINATION
3	05/21/18	LANDSCAPE COORDINATION
4	05/21/18	FINAL COMMISSION COMMENTS
5	05/21/18	100% CONSTRUCTION DOCUMENTS

JOB NO. 23318

DRAWN: DHM

CHECKED: JOW

SCALE: 1:10

L-1
DRAWING NO.

City of Key West Tree Commission Tree List Staff--Marty's Place

10-31-18 Final Landscape Plan

Tree #	Common Name/Scientific Name	DBH/Height	Condition	Location	Species	Value	Replacements	Status	Condition	Request
1	Black Olive/Bucida buceras	26.7" - 24" = 1.1" dbh	50%	80%	0%	43%	1.1" dbh	Regulated	Codominant	Transplant
2	Chinese Fan Palm/Livistona chinensis	4 ft tall					NA	NPR	Poor	Remove
3	Bridalveil/Caesalpinia grandillo	4" dbh					NA	Regulated	partially uprooted	Transplant
4	Pigeon Plum/Coccoloba diversifolia	2.75" dbh	30%	80%	100%	70%	1.9" dbh	Protected	Poor, partially uprooted, thin canopy, 45' angle lean	Remove
5	Paradise/Simaruba glauca	6" dbh	30%	80%	100%	70%	4.2" dbh	Protected	Poor, thinning canopy, circling roots, one sided, tip dieback	Remove
6	Fishtail Palm/Caryota mitis	NA					NA	NPR		Remove
7	Paradise/Simaruba glauca	6.5" dbh	30%	80%	100%	70%	4.5" dbh	Protected	Tip and branch dieback, lead and canopy top dead	Remove
8	Bridalveil/Caesalpinia grandillo	6.5" dbh	40%	80%	50%	56%	3.6" dbh	Regulated	Poor, codominant with included bark	Remove
9	Frangipani 'Key West'/Plumeria	4.5" dbh					NA	Regulated	fair- Good	Retain
10	Gumbo Limbo/Bursea simaruba	16.5" dbh	50%	80%	100%	76%	12.5" dbh	Protected	Low branching codominant with included bark	Remove
11	Coconut (2)/Cocos nucifera	18'-20' tall					1-Palm	Protected		Remove
12	Coconut/Cocos nucifera	23'-25' tall					1-Palm	Protected		Remove
13	Ficus 'Strangler' Fig/Ficus aurea	2" dbh	60%	80%	100%	80%	1.6" dbh	Protected	young tree shape	Remove
14	Christmas Palm (3)/Adonidia merrillii	8'-9' tall					NA	NPR		Transplant
15	Washington Palm/Washingtonia robusta	25'-30' tall					1-Palm	Regulated		Remove
16	Christmas Palm/Adonidia merrillii	18'-20' tall					1-Palm	Regulated		Transplant
17	Christmas Palm/Adonidia merrillii	12'-15' tall					1-Palm	Regulated		Transplant
18	Weeping Fig/ Ficus benjamina	NA					NA	NPR		Remove
19	Christmas Palm/Adonidia merrillii	10'-12' tall					1-Palm	Regulated		Transplant
20	Christmas Palm/Adonidia merrillii	10'-12' tall					1-Palm	Regulated		Transplant
21	Christmas Palm/Adonidia merrillii	10'-12' tall					1-Palm	Regulated		Retain
22	Christmas Palm (2)/Adonidia merrillii	18'-25' tall					1-Palm	Regulated		Transplant
23	Christmas Palm/Adonidia merrillii	10'-13' tall					1-Palm	Regulated		Transplant
24	Ficus/Ficus aurea	4.5-5' dbh	NA	NA	NA	NA	NA	Protected	Fair, storm and utility pruning damage	Retain
25	Christmas Palm/Adonidia merrillii	18'-20' tall					1-Palm	Regulated		Transplant
26	Christmas Palm (2)/Adonidia merrillii	18'-20' tall					1-Palm	Regulated		Transplant
27	Christmas Palm/Adonidia merrillii	18'-20' tall					1-Palm	Regulated		Transplant
28	Spanish Stopper/Eugenia foetida	1" dbh	60%	80%	100%	80%	0.8" dbh	Protected	Fair	Remove
29	Christmas Palm/Adonidia merrillii	10'-12' tall					1-Palm	Regulated		Remove

30	Christmas Palm/Adonidia merrillii	18'-20' tall						1-Palm	Regulated		Retain
31	Christmas Palm (4)/Adonidia merrillii	12'-20' tall						1-Palm	Regulated		Retain
32	Ficus 'Shortleaf'/Ficus citrifolia	9.5" dbh			NA		NA	Protected	fair		Transplant
33	Crabwood/Gymnanthes lucida	1.75" dbh	40%	80%	100%	73%	1.2" dbh	Protected	Storm Damage		Remove
34	Spanish Stopper/Eugenia foetida	1" dbh			NA		NA	Protected	Fair		Transplant
35	Crabwood/Gymnanthes lucida	1.5" dbh			NA		NA	Protected	Good		Transplant
36	Coconut Palm/Cocos nucifera	15'-18' tall						1-Palm	Protected		Remove
37	Areca Palm/Dypsis lutescens	NPR						NA	NPR		Remove
38	Silver buttonwood/Conocarpus erectus sericeus	1.5" dbh	50%	40%	100%	63%	0.9" dbh	Regulated	lollipped		Remove
39	Silver buttonwood/Conocarpus erectus sericeus	8.75" dbh	50%	40%	100%	63%	5.5" dbh	Regulated	lollipped		Remove
40	Christmas Palm (5)/Adonidia merrillii	8'-20' tall						1-Palm	Regulated		Retain
41	Christmas Palm (3)/Adonidia merrillii	6'-18' tall						1-Palm	Regulated		Retain
42	Areca Palm/Dypsis lutescens	NA						NA	NPR		Retain
43	Alexander Palm/Ptychosperma elegans	18'-20' tall						1-Palm	Regulated		Transplant
44	Christmas Palm (2)/Adonidia merrillii	15'-18' tall						1-Palm	Regulated		Transplant
45	Christmas Palm (3)/Adonidia merrillii	10'-18' tall						1-Palm	Regulated		Transplant
46	Christmas Palm (2)/Adonidia merrillii	16'-20' tall						1-Palm	Regulated		Transplant
47	Christmas Palm (3)/Adonidia merrillii	16'-20' tall						1-Palm	Regulated		Retain
48	Ficus 'Strangler' shrub/Ficus aurea	NA						NA	NPR	Poor, maintained as tall hedge/shrub	Remove
49	Areca Palm/Dypsis lutescens	NA						NA	NPR		Remove
50	Ficus 'Strangler' shrub/Ficus aurea	NA						NA	NPR	Poor, maintained as tall hedge/shrub	Remove
51	Christmas Palm/Adonidia merrillii	10'-12' tall						1-Palm	Regulated		Transplant
52	Areca Palm/Dypsis lutescens	NA						NA	NPR		Remove
53	Christmas Palm/Adonidia merrillii	15'-18' tall						1-Palm	Regulated		Transplant
54	Areca Palm/Dypsis lutescens	NA						NA	NPR		Remove
55	Christmas Palm/Adonidia merrillii	15'-18' tall						1-Palm	Regulated		Remove
56	Gumbo Limbo/Bursea simaruba	10.25" dbh	60%	80%	100%	80%	8.2" dbh	Protected			Transplant
57	Barbados Cherry/Malpighia glabra	7.5" dbh	60%	80%	50%	63%	4.7" dbh	Regulated	Fair, some dieback, multi trunked with trunk damage		Remove
58	Christmas Palm/Adonidia merrillii	NA						NA	NPR		Transplant
59	Blue Latania/Latania loddigesii	NA						NA	NPR	Good	Transplant
60	Areca Palm/Dypsis lutescens	NA						NA	NPR		Remove
61	Christmas Palm/Adonidia merrillii	15'-18' tall						1-Palm	Regulated		Transplant
62	Coconut Palm/Cocos nucifera	15'-18' tall						1-Palm	Protected		Remove
63	Areca Palm/Dypsis lutescens	NA						NA	NPR		Remove
64	Locustberry/Byrsonima lucida	2.5" dbh			NA		NA	Protected	Fair		Transplant
65	Spicewood/Calyptanthus pallens	4" dbh			NA		NA	Protected	Fair		Transplant
66	Verawood/Bulnesia arborea	3" dbh			NA		NA	Protected	Fair		Transplant
67	Jamaica Caper/Capparis cynophallophora	2' tall						NA	NPR		Transplant
68	Coconut Palm/Cocos nucifera	20' tall						1-Palm	Regulated		Transplant
69	Chinese Fan Palm (3)/Livistona chinensis	NA						NA	Protected		Remove
70	Areca Palm/Dypsis lutescens	NA						NA	NPR		Remove
71	Christmas Palm (3)/Adonidia merrillii	18'-25' tall						1-Palm	Regulated	Outside fence	Transplant
72	Christmas Palm/Adonidia merrillii	NA						NA	NPR		Transplant
73	Poinciana/Delonix regia	14.75" dbh	60%	70%	100%	76%	11.2" dbh	Protected			Remove
74	Christmas Palm (2)/Adonidia merrillii	15'-20' dbh						1-Palm	Regulated		Remove

75	Gumbo Limbo/Bursea simaruba	8.5" dbh	50%	70%	100%	73%	6.2" dbh	Protected	Poor	Remove
76	Christmas Palm (3)/Adonidia merrillii	12'- 15' dbh					1-Palm	Regulated		Transplant
77	Areca Palm/Dyopsis lutescens	NA					NA	NPR		Remove
78	Christmas Palm (2)/Adonidia merrillii	10'-12' tall					1-Palm	Regulated		Transplant
79	Areca Palm/Dyopsis lutescens	NA					NA	NPR		Remove
80	Triangle Palm/Dyopsis decaryi	NA					NA	NPR		Remove
81	Orange Geiger/Cordia sebestena	1" dbh	40%	70%	100%	70%	0.7" dbh	Protected	Re-sprout, poor	Remove
82	Spanish Stopper/Eugenia foetida	3" dbh			NA		NA	Protected	Good	Transplant
83	Areca Palm/Dyopsis lutescens	NA					NA	NPR		Remove
84	Gumbo Limbo/Bursea simaruba	20.75"	60%	80%	100%	80%	16.6" dbh	Protected	Fair, codominant, some included bark	Remove
85	Areca Palm/Dyopsis lutescens	NA					NA	NPR		Remove
86	Areca Palm/Dyopsis lutescens	NA					NA	NPR		Remove
87	Coconut Palm/Cocos nucifera	18'-20' tall					1-Palm	Protected		Remove
88	Green Thatch Palm/Thrinax radiata	5.5' all over height			NA		NA	Protected	Good	Transplant
89	Silver buttonwood/Conocarpus erectus sericeus	5"	40%	60%	100%	66%	3.3" dbh	Protected	lollipopped	Remove
90	Bay Cedar/Suriana maritima	1"	50%	80%	100%	76%	0.7" dbh	Protected	Topped	Remove
91	Green Buttonwood/Conocarpus erectus	5.75"	40%	80%	100%	73%	6.4" dbh	Protected	Poor, Heavy Canopy one-sided, leaning west 45'	Remove
92A	Christmas Palm/Adonidia merrillii	9' tall					NA	NPR	??	Transplant
92B	Christmas Palm (3)/Adonidia merrillii	3'-10' tall					1-Palm	Regulated	??	Transplant
93	Yellow Tab-Silver Trumpet/Tabebuia caraiba	12.5"	40%	80%	50%	56%	7" dbh	Regulated	Poor, main trunk dog-leg west 45' angle, tip dieback	Remove
94	Christmas Palm/Adonidia merrillii	8'-10' tall					NA	Regulated		Transplant
95	Gumbo Limbo/Bursea simaruba	12" dbh	40%	70%	100%	70%	8.4" dbh	Protected	Poor, 4 multi-trunk total 12", Codominant at 1' above grade	Remove
96	Coconut Palm (2)/Cocos nucifera	20'-25' tall					1-Palm	Protected		Remove
97	Thrinax morrisii/Leucothrinax morrisii	6' tall			NA		NA	Protected	Good	Transplant
98	Frangipani/Plumeria	4" dbh	40%	80%	50%	56%	2.2" dbh	Regulated	Poor, leaning west 45' angle	Transplant
99	White Bird of Paradise/Strelitzia nicolai	NA					NA	NPR		Remove
100	Green Thatch/Thrinax radiata	8' tall			NA		NA	Protected	Good	Transplant
101	Thrinax morrisii/Leucothrinax morrisii	6' tall			NA		NA	Protected	Good	Transplant
102	Gumbo Limbo/Bursea simaruba	12.5" dbh	60%	70%	100%	76%	9.5" dbh	Protected	Fair, included bark, over-lifted, limbs pruned away from structures	Retain
103	White Bird of Paradise/Strelitzia nicolai	NA					NA	NPR		Remove
104	Coconut Palm/Cocos nucifera	25'-30'					1-Palm	Protected		Remove
105	Green Thatch/Thrinax radiata	8' tall			NA		NA	Protected	Good	Transplant
106	Yellow Tab.-Silver Trumpet/Tabebuia caraiba	12.5" dbh	50%	80%	50%	60%	7.5" dbh	Regulated	Poor, Storm damage with decay, very few leaves	Remove

107	Coccothrinax miraguama	3'-6' tall, triple			NA		NA	Protected	Good	Transplant
108	Red Stopper/Eugenia rhombea	1" dbh			NA		NA	Protected	Fair	Transplant
109	Christmas Palm/Adonidia merrillii	12'-15' tall					1-Palm	Regulated		Transplant
110	Alexander Palm/Ptychosperma elegans	4'-10' tall					1-Palm	Regulated		Remove
111	Fiddlewood/Citharexylum spinosum	3.75" dbh	10%	60%	100%	56%	2.1" dbh	Protected	Poor, storm damage, very few leaves, mostly dead	Remove
112	Bahama Tab/Tabebuia bahamensis	NA					NA	NPR	Poor, tip and branch die-back	Remove
113	Simpson Stopper/Myrcianthes fragrans	NA					NA	NPR	Fair	Transplant
114	Simpson Stopper/Myrcianthes fragrans	NA					NA	NPR	Fair	Transplant
115	Simpson Stopper/Myrcianthes fragrans	NA					NA	NPR	Fair	Transplant
116	Bahama Tab/Tabebuia bahamensis	NA					NA	NPR	Fair, Tip die-back, one sided	Remove
117	Washington Palm/Washingtonia robusta	NA					NA	NPR		Remove
118	Simpson Stopper/Myrcianthes fragrans	NA					NA	NPR	Poor, topped	Transplant
119	Bahama Tab/Tabebuia bahamensis	NA					NA	NPR	tip die-back, major mechanical damage	Remove
120A	Black Bead (2)/Pithecellobium keyense	NA					NA	NPR	Hedged	Remove
120B	Black Bead (2)/Pithecellobium keyense	NA					NA	NPR	Hedged	Transplant
121	Washington Palm (2)/Washingtonia robusta	15' tall					1-Palm	Regulated	Poor, multiple stem, 12'-15' wood	Remove
122	Washington Palm (3)/Washingtonia	2'-18' tall					1-Palm	Regulated		Remove
123	Washington Palm/Washingtonia robusta	10'-13' tall					1-Palm	Regulated		Remove
124	Black Bead/Pithecellobium keyense	NA					NA	NPR	Hedged	Remove

Regulated Tree/Palm Transplants

Regulated Palm Removals

Regulated Tree Removals

TREE Regulated Trees Remaining

TREE Not Regulated Trees/Palms Being Transplanted

Application



2018 - 00027
2018 - 0033

Tree Permit Application

Date: 09/19/2018

Please Clearly Print All Information unless indicated otherwise.

Tree Address 1515-1525 Bertha Street & 1512 Dennis Street
Cross/Corner Street Bertha St., Dennis St. and Venetia St.
List Tree Name(s) and Quantity See attached landscape plan
Species Type(s) check all that apply () Palm () Flowering () Fruit () Shade () Unsure
Reason(s) for Application:
 () REMOVE () Tree Health () Safety () Other/Explain below
 () TRANSPLANT () New Location () Same Property () Other/Explain below
 () HEAVY MAINTENANCE () Branch Removal () Crown Cleaning/Thinning () Crown Reduction
Additional Information and Explanation Final landscape approval per attached plan
Property Owner Name A.H. of Monroe County Inc. & AHI Real Estate Properties, Inc.
Property Owner eMail Address scott.pridgen@ahmonroe.org
Property Owner Mailing Address P.O. Box 4374
Property Owner Mailing City Key West **State** FL **Zip** 33041-4374
Property Owner Phone Number () _____ - _____
Property Owner Signature _____

Representative Name Trepanier & Assoc. & Cynthia Coogle
Representative eMail Address lori@owentrepanier.com
Representative Mailing Address 1421 1st Street Unit 101
Representative Mailing City Key West **State** FL **Zip** 33040
Representative Phone Number (305) 293 - 8983

NOTE: A Tree Representation Authorization form must accompany this application if someone other than the owner will be representing the owner at a Tree Commission meeting or picking up an issued Tree Permit.

Tree Representation Authorization form attached ()

<<<<< Sketch location of tree in this area including cross/corner Street >>>>>

Please identify tree(s) with colored tape

If this process requires blocking of a City right-of-way, a separate ROW Permit is required. Please contact 305-809-3740.



Tree Representation Authorization

Date: 05/21/2018

Attendance at the Tree Commission meeting on the date when your request will be discussed is necessary in order to expedite the resolution of your application. This Tree Representation Authorization form must accompany the application if the property owner is unable to attend or will have someone else pick up the Tree Permit once issued.

Please Clearly Print All Information unless indicated otherwise.

Tree Address 1515-1525 Bertha Street & 1512 Dennis Street

Property Owner Name A.H. of Monroe County, Inc. & A H I Real Estate Properties, Inc.

Property Owner eMail Address scott.pridgen@ahmonroe.org

Property Owner Mailing Address P.O. Box 4374

Property Owner Mailing City Key West **State** FL **Zip** 33041-4374

Property Owner Phone Number (305) 296 - 6196

Property Owner Signature Eugene Scott Pridden

Representative Name Trepanier & Associates, Inc. & Janet Whitmill R. L.A., Inc.

Representative eMail Address owen@owentrepanier.com

Representative Mailing Address 1421 1st Street Unit 101

Representative Mailing City Key West **State** FL **Zip** 33040

Representative Phone Number (305) 293- 8983

I Eugene Scott Pridden, hereby authorize the above listed agent(s) to represent me in the matter of obtaining a Tree Permit from the City of Key West for my property at the tree address above listed. You may contact me at the telephone listed above is there is any questions or need access to my property.

Property Owner Signature Eugene Scott Pridden

The forgoing instrument was acknowledged before me on this 22 day May, 2018.

By (Print name of Affiant) Eugene Scott Pridden who is personally known to me or has produced _____ as identification and who did take an oath.

NOTARY PUBLIC

Sign Name: Joan E. Higgs Notary Public - State of Florida (seal)

Print Name: Joan E. Higgs

My Commission Expires: 05/28/2019



Karen DeMaria

From: Lori Thompson <lori@owentrepanier.com>
Sent: Wednesday, October 24, 2018 3:01 PM
To: Karen DeMaria
Cc: Owen Trepanier; Scott Pridgen; Elena Adames
Subject: 1515 Bertha - Marty's Place final landscape plan
Attachments: Binder.final10.24.18.pdf

Good afternoon Karen,

Attached is the final landscape plan for Marty's Place for the Nov. 13th Tree Commission agenda. There has been a redesign of the parking area in the back, building facing Dennis was shifted slightly towards Venetia, and parallel parking was added along Dennis St. The black olive is showing as a transplant as well as some Christmas Tree Palms along the back which fell within parking spaces.

New relocated trees on site include tree numbers: 1, 56, 42,43,44,45,46.

Please don't hesitate to contact me if you have any questions.

Best regards,

Lori Thompson

Trepanier & Associates

www.owentrepanier.com

1421 First Street, Key West Florida 33040

Phone: 305.293.8983 / FAX: 305.293.8748

Karen DeMaria

From: Lori Thompson <lori@owentrepanier.com>
Sent: Thursday, October 25, 2018 2:37 PM
To: Karen DeMaria
Cc: Scott Pridgen
Subject: Transplant plans for 1515 Bertha St. - Marty's Place

Good afternoon Karen,

AH has reached out to several parties in the local community who they thought would be interested in the plants that may come available for transplanting if approved at the November Tree Commission Hearing. AH would like to make plants available to the general public at a future designated date and time.

The groups who have responded with interest are:

Interested Party	Contact person	Relocation site
AHI	Scott Pridgen	Other AH properties
ICAMCO	Nick CuvIELLO	Key Cove
Key West Golf Club (HOA)	Randy Niles	Residential
Key West Golf Club	Dzongkha	Golf Course

AH will manage a transplant list of tree # and relocation site. Please do not hesitate to contact me if you have any questions.

Best regards,

Lori Thompson

Trepanier & Associates

www.owentrepanier.com

1421 First Street, Key West Florida 33040

Phone: 305.293.8983 / FAX: 305.293.8748