



THE CITY OF KEY WEST

3140 Flagler Ave
Key West, FL 33040

May 19, 2013

To: All Prospective Bidders

Pursuant to the City of Key West's Code of Ordinances Section 2-769: Invitation to Bid (ITB) , the City of Key West (CITY) is soliciting competitive sealed Bids for the POLICE STATION WINDOWS REPLACEMENT: ITB NO: 13-003. This package contains the following documents.

Bid Document twenty-four (24) pages in length
Public Entity Crimes Certification two (2) pages in length
Anti-Kickback Affidavit one (1) page in length
City of Key West Indemnification one (1) page in length
Local Vendor Certification one (1) page in length
City Ordinance Sec. 2-799 five (5) pages in length
Contract Forms sixteen (16) pages in length
Conditions thirty-nine (39) pages in length
Technical Specifications/Drawings six (6) pages in length

Please review your package to ensure it contains all of these documents. If not, contact Sue Snider, City of Key West Purchasing Agent at (305) 809-3815, immediately, to obtain copies of any missing document(s). Please contact Doug Bradshaw, Senior Project Manager (305) 809-3792 with questions concerning the project.

Firms/corporations submitting a Bid should ensure that the following documents are completed, certified, and returned as instructed: Bid Form, Anti-Kickback Affidavit, Public Entity Crimes Certification, Local Vendor Certification, Domestic Partner Affidavit, past project history, etc.

BID DOCUMENTS
FOR
POLICE STATION WINDOWS
REPLACEMENT

CONSISTING OF:

BIDDING REQUIREMENTS
CONTRACT FORMS
CONDITIONS
TECHNICAL SPECIFICATIONS/DRAWINGS

ITB PROJECT #:13-003

PREPARED BY:

THE CITY OF KEY WEST
KEY WEST, FLORIDA

May 19, 2013

TABLE OF CONTENTS

PART 1: BIDDING REQUIREMENTS

Information to Bidders
Invitation to Bid
Instructions to Bidders
City of Key West Licenses, Permits, and Fees
Bid Form
Florida Bid Bond
Public Entities Crime Form
Anti – Kickback Affidavit
City of Key West Indemnification
Local Vendor Certification
City Ordinance Sec. 2-799

PART 2 CONTRACT FORMS

Notice of Award
Contract
Performance/Payment Bonds
Ben Few Insurance Requirement Memo and Sample Endorsement
Notice to Proceed

PART 3 CONDITIONS

Conditions of Bid
General Conditions
Supplementary Conditions
Special Conditions

PART 4 TECHNICAL SPECIFICATIONS/DRAWINGS

PART 1

BIDDING REQUIREMENTS

INFORMATION TO BIDDERS

SUBJECT: INVITATION TO BID NO. 13-003: POLICE STATION
WINDOWS REPLACEMENT

ISSUE DATE: MAY 19, 2013

PRE BID CONFERENCE: MANDATORY: JUNE 4, 2013, 10:00 AM LOCAL TIME,
KEY WEST POLICE STATION, 1604 NORTH
ROOSEVELT BLVD

MAIL OR SPECIAL
DELIVERY REPOSSES TO: CITY CLERK
CITY OF KEY WEST
3126 FLAGLER AVE
KEY WEST, FL 33040

DELIVER BIDS TO: SAME AS ABOVE

BIDS MUST BE
RECEIVED: JUNE 19, 2013

NOT LATER THAN: 3:30 P.M. LOCAL TIME

SUE SNIDER
PURCHASING AGENT
CITY OF KEY WEST

ses

Enclosures

INVITATION TO BID

Sealed Bids addressed to the City of Key West (CITY), for the Invitation to Bid (ITB) # 13-003: POLICE STATION WINDOWS REPLACEMENT will be received at the office The Clerk of the City of Key West at 3126 Flagler Ave, Key West, Florida 33040, until 3:30 p.m., local time, on June 19, 2013 and then will be publicly opened and read. Any Bids received after the time and date specified will not be considered.

The project contemplated consists of providing all materials, equipment and labor necessary to accomplish the following:

- Replacement of all windows at the Key West Police Station
- Repair/modification of the 63 window openings

Drawings and Specifications may be obtained from DemandStar by Onvia or from the City of Key West website (www.keywestcity.com). Please contact DemandStar at www.demandstar.com or call 1-800-711-1712.

There will be a mandatory prebid meeting on June 4, 2013, 10:00 AM local time at the Key West Police Station, 1604 North Roosevelt Blvd, Key West, FL. Contractors that do not have a representative at the prebid meeting will not be allowed to submit a bid.

Each Bid must be submitted on the prescribed forms and accompanied by Bid security. Bid or BID security shall be by cash, by certified or cashier's check, by a Bid bond or an irrevocable letter of credit made payable to the city and provided by a surety company authorized to do business as a surety in the state in an amount not less than five percent of the amount of the Bid or BID. Performance and Payment Bonds in an amount equal to 100% of contract value will be required as part of this contract.

One (1) original, one (1) copy, and 2 CD copies or flash drives in PDF format of the Bid are to be submitted in two sealed envelopes, one within the other, clearly marked on the outside "ITB #13-003: POLICE STATION WINDOWS REPLACEMENT", and addressed to the City Clerk.

Bidders must hold and furnish documentation of all State of Florida licenses, certifications, registrations or competency cards required in order to Bid and perform the work specified herein.

The successful Bidder will be required to show that he/she is in compliance with the provisions of Chapter 66 of the Code of Ordinances of the City of Key West within 10-days of Notice of Award. The successful Bidder must demonstrate that he/she holds, as a minimum, the following licenses and certificates:

- A. City of Key West License as defined in the Code of Ordinances, Chapter 66, enabling the Contractor to perform the work stated herein.
- B. A valid Certificate of Competency issued by the Chief Building Official of the City of Key West, which shall be valid throughout the contract time.

C. A valid Business Tax Receipt issued by the City of Key West.

All Bid bonds, insurance contracts, and certificates of insurance shall be either executed by or countersigned by a licensed resident agent of the Surety or insurance company having his/her place of business in the State of Florida, and in all ways complying with the insurance laws of the State of Florida. Further, the said Surety or insurance company shall be duly licensed and qualified to do business in the State of Florida.

Before a Contract will be awarded for the work contemplated herein, the Owner will conduct such investigation as is necessary to determine the performance record and ability of the apparent lowest, qualified Bidder to perform the size and type of work specified under this Contract. Upon request, the Bidder shall submit such information as deemed necessary by the Owner to evaluate the Bidder's qualifications.

For information concerning the proposed work, or for appointment to visit the site of the proposed work, contact Doug Bradshaw, Senior Project Manager at (305) 809-3792 or email at dbradsha@keywestcity.com.

Prior to award by the CITY the successful Bidder must be able to prove that Bidder held State Licenses prior to submittal of Bid as would be required to perform work herein. Within 10-days after issuance of the Notice of Award, the successful Bidder must be able to prove that Bidder holds City Licenses as would be required to perform work herein. Any permit and/or license requirement and subsequent costs are located within the Bid document. The successful Bidder must also be able to satisfy the City Attorney as to such insurance coverage, and legal requirements as may be demanded in Bid. The CITY may reject Bids: (1) for budgetary reasons, (2) if the Bidder misstates or conceals a material fact in its Bid, (3) if the Bidder does not strictly conform to the law or is non-responsive to Bid requirements, (4) if the Bid is conditional, (5) if a change of circumstances occurs making the purpose of the Bid unnecessary or (6) if such rejection is in the best interest of the CITY. The CITY may also waive any minor informalities or irregularities in any Bid.

INSTRUCTIONS TO BIDDERS

1. CONTRACT DOCUMENTS **FORMAT**

The Contract Documents are divided into parts, divisions, and sections for convenient organization and reference. Generally, there has been no attempt to divide the Specification sections into work performed by the various building trades, work by separate subcontractors, or work required for separate facilities in the project.

The intent of the Documents is to describe a functionally complete project (or part thereof) to be constructed in accordance with the Contract Documents. Any work, materials, or equipment that may reasonably be inferred from the Contract Documents, as being required to produce the intended result shall be supplied whether or not specifically called for.

DOCUMENT INTERPRETATION

The separate sections contained within these Contract Documents are intended to be mutually cooperative and to provide all details reasonably required for the execution of the proposed work.

Should there be any doubt as to the meaning or intent of said Contract Documents, the Bidder should request of the Project Manager, in writing, at least ten (10) calendar days prior to the Bid opening, an interpretation thereof. Any interpretation or change in said Contract Documents will be made only in writing, in the form of addenda to the Documents which will be furnished through DemandStar to all registered holders of the Contract Documents. Bidders shall submit with their Bids, or indicate receipt of, all Addenda. The Owner will not be responsible for any other explanation or interpretations of said Documents.

2. DESCRIPTION OF THE PROJECT

The work to be completed for this project can be found in Section 4. The Bidder will be required to complete all work as specified.

3. QUALIFICATION OF CONTRACTORS

Bidders must hold all licenses, certifications, registrations or competency cards required by Florida Statute and local ordinances in order to perform the work specified herein.

4. BIDDER'S UNDERSTANDING

Each Bidder must inform him/herself of the conditions relating to the execution of the work, and it is required that he/she will inspect the site(s) and make himself/herself thoroughly familiar with the Bid Documents. Failure to do so will not relieve the successful Bidder of his/her obligation to enter into a Contract and complete the

contemplated work in strict accordance with the Bid Documents. It shall be the Bidder's obligation to verify for himself and to his complete satisfaction all information concerning site and construction or worksite conditions.

The Owner will make available to prospective Bidders upon request and at the office of the Project Manager, prior to Bid opening, any information that he/she may have as to conditions at the worksites.

Investigations conducted by the Project Manager of any locations were made for the purpose of study and design, and the Project Manager assumes no responsibility whatever in respect to the sufficiency or accuracy of data or other investigations that have been made, or of the interpretations made thereof, and there is no warranty or guaranty, either express or implied, that the conditions indicated by such investigations are representative of those existing throughout such area, or any part thereof, or that unforeseen developments may not occur.

Copies of any existing documents regarding the work sites can be viewed at the City offices of Engineering, 3140 Flagler Ave, and any that are made available shall not be considered a part of the Contract Documents, said documents are made available only for the convenience of the Bidders.

Information derived from Drawings showing location of utilities and structures will not in any way relieve the contractor from any risk, or from properly examining the site and making such additional investigations as he/she may elect, or from properly fulfilling all the terms of the Contract Documents.

Each Bidder shall inform him/herself of, and the Bidder awarded a Contract shall comply with, federal, state, and local laws, statutes, and ordinances relative to the execution of the work. This requirement includes, but is not limited to, applicable regulations concerning minimum wage rates, nondiscrimination in the employment of labor, protection of public and employee safety and health, environmental protection, the protection of natural resources, fire protection, burning and non-burning requirements, permits, fees, and similar subjects. Performance and Payment Bonds are not required as part of this contract.

5. TYPE OF BID

A. LUMP SUM

The Bid for the work is to be submitted on a LUMP SUM basis. LUMP SUM prices shall be broken down on a unit price basis for each part of the project in the Bid and a Schedule of Values shall be included with the Bid. The total amount to be paid the Contractor shall be the amount of the Lump Sum Bid as adjusted for additions or deletions in number of units and/or resulting from Owner authorized changes in the project or by actual number of units used in construction. The owner reserves the right to

enter into a contract for all or portions of the project and to adjust the final Lump Sum accordingly.

B. PREPARATION OF BIDS

GENERAL

All blank spaces in the Bid form must be filled in, as required, in **BLACK INK** or **TYPED**. All price information will be shown in both words and figures where required. No changes shall be made in the phraseology of the forms. Written amounts shall govern in case of discrepancy between amounts stated in writing and the amounts stated in figures.

Any Bid shall be deemed informal, which contains omissions, erasures, alterations, or additions of any kind, or prices uncalled for, or in which any of the prices are obviously unbalanced, or which in any manner shall fail to conform to the conditions of the published ITB.

Bidders shall not submit unbalanced Bids as requested in the breakdown of Bids.

Only one (1) Bid from any individual, firm, partnership, or corporation under the same or different names, will be considered. Should it appear to the Owner that any Bidder is interested in more than one (1) Bid for work contemplated, all Bids in which such Bidder is interested will be rejected.

SIGNATURE

The Bidder shall sign his/her Bid in the blank space provided therefore. If Bidder is a corporation, the legal name of the corporation shall be set forth above, together with the signature of the officer or officers authorized to sign Contracts on behalf of the corporation. If the Bidder is a partnership, the true name of the firm shall be set forth above, together with the signature of the partner or partners authorized to sign Contracts on behalf of the partnership. If signature is by an agent, other than an officer of a corporation or a member of a partnership, a notarized power of attorney must be on file with the Owner prior to opening of Bids or submitted with the Bid, otherwise the Bid will be regarded as not properly authorized.

SPECIAL BIDDING REQUIREMENTS

The Bidder's attention is brought to the hiring practices and licenses and permits of the City of Key West. These are defined in the addition to Article 39, **CODES, ORDINANCES, PERMITS, and LICENSES**.

ATTACHMENTS

Bidder shall complete and submit the following forms with his Bid or as otherwise identified in the Bid document:

- Bid Form including detail schedule of values,
- Sworn statement under section 287.133(3)(a) Florida Statutes, on public entity crimes,
- Anti-Kickback Affidavit
- Local Vendor Certification
- Equal Benefits for Domestic Partner Affidavit
- At least three (3) years of current or recent projects of similar work shall be provided (dates of works and contacts shall be included),
- A description of any previous or existing legal action against the Bidder within the past three (3) years. If none, Bidder shall state this fact in writing.
- All Bidders shall include with their Bid package their complete Bid on a CD or flash drive in one (1) PDF format file (two CDs or flash drives are required with the Bid)

Note: if any of the items above or as required in other parts of the document are not included in the Bid, the Bid will be considered nonresponsive and therefore will be rejected unless City Commission directs otherwise.

7. STATE AND LOCAL SALES AND USE TAX

The Owner is exempt from state sales tax on materials incorporated into the work due to the qualification of the work under this Contract, the Contractor, as required by the laws and statutes of the state and its political subdivisions shall pay all state and local sales and use taxes unless stated differently in these documents. Prices quoted in the Bid shall include all nonexempt sales and use taxes, unless provision is made in the Bid form to separately itemize the tax.

8. SUBMISSION OF BIDS

All Bids must be submitted not later than the time prescribed, at the place, and in the manner set forth in the ITB. Bids must be made on the Bid forms provided herewith.

Each Bid must be submitted in two sealed envelopes, one within the other, so marked as to indicate the Bidder's name and its contents without being opened, and addressed in conformance with the instructions in the ITB. One original, one copy, and 2 CD copies or flash drives are required.

9. MODIFICATIONS OR WITHDRAWAL OF BIDS

Prior to the time and date designated for receipt of Bids, any Bid submitted may be modified or withdrawn by notice to the party receiving Bids at the place designated for the receipt of Bids. Such notice shall be in writing over the signature of the Bidder or by telephone, fax, or email. If by telephone, fax, or email, written confirmation over the

signature of the Bidder shall be mailed and postmarked on or before the date and time set for receipt of Bids, and it shall be so worded as not to reveal the amount of the original Bid. No Bid may be withdrawn after the time scheduled for the opening of Bids, unless the time specified in paragraph 12, AWARD OF CONTRACT, in these Instructions to Bidders shall have elapsed.

10. BID SECURITY

The Attorney-in-Fact who executes this bond in behalf of the Surety must attach a notarized copy of his/her power-of-attorney as evidence of his/her authority to bind the certification by a resident agent shall also be provided.

Bid or BID security shall be by cash, by certified or cashier's check, by a Bid bond or an irrevocable letter of credit made payable to the city and provided by a surety company authorized to do business as a surety in the state.

11. RETURN OF BID SECURITY

Within fifteen (15) days after the award of the Contract or at the discretion of the Project Manager, the Owner will return the Bid securities to all Bidders whose Bids are not to be further considered in awarding the Contract. Retained Bid securities will be held until the Contract has been finally executed, after which all Bid securities, other than Bidder's Bonds and any guarantees which have been forfeited, will be returned to the respective Bidders whose Bids they accompanied.

12. AWARD OF CONTRACT

Within ninety (90) calendar days after the opening of the Bids, the Owner will accept one of the Bids or will act in accordance with the following Section 13 of the Part 3: Conditions of Bid. The acceptance of the Bid will be by written notice of award, mailed to the office designated in the Bid, or delivered to the Bidder's representative. In the event of failure of the lowest, responsive, qualified Bidder to sign the Contract and provide acceptable insurance certificate(s), the Owner may award the Contract to the next lowest, responsive, qualified Bidder. Such award, if made, will be made within ninety (90) days after the opening of the Bids.

Bid Award will be the date of the Notice of Award letter. Any permit and/or license requirement and subsequent costs are located within the documents. The successful Bidder must also be able to satisfy the City Attorney as to such insurance coverage and legal requirements as may be demanded by the Bid in question. The Owner reserves the right to reject any and/or all Bids because of irregularities or due to budgetary considerations, to waive irregularities or informalities in any or all Bids, and to accept any Bid that the CITY OF KEY WEST deems to be in the best interest of the Owner.

13. BASIS OF AWARD

The Owner on the basis of that Bid will make the award on base bid or a combination of base bid and alternate bids from the lowest, responsive, qualified Bidder that in the Owner's sole and absolute judgment will serve the best interests of the Owner.

If at the time this Contract is to be awarded, the total of the lowest acceptable Bid exceeds the funds then estimated by the Owner as available, the Owner may reject all Bids or take such other action as best serves the Owner's interest.

14. EXECUTION OF CONTRACT

The successful Bidder shall, within ten (10) working days after receiving notice of award, sign and deliver to the Owner the Contract together with the acceptable insurance certificates as required in these Documents. Within ten (10) working days after receiving the signed Contract, with acceptable insurance from the successful Bidder, the Owner's authorized agent will sign the Contract. Signature by both parties constitutes execution of the Contract.

15. FAILURE TO EXECUTE CONTRACT AND FURNISH BONDS

The Bidder who has a contract awarded to him/her and who fails to promptly and properly execute the contract shall forfeit the Bid security that accompanied his Bid, and the Bid security shall be retained as liquidated damages by the Owner, and it is agreed that said sum is a fair estimate of the amount of the damages the Owner will sustain in case the Bidder fails to enter into a Contract or furnish the required bonds. Bid security deposited in the form of cash, a certified check, or cashier's check shall be subject to the same requirements as a Bid Bond. Performance and Payment Bonds in an amount equal to 100% of contract value will be required as part of this contract.

16. PERFORMANCE OF WORK BY CONTRACTOR

The Contractor shall perform on site and with his/her own organization, labor equivalent to at least forty (40) percent of the total amount of the work to be performed under this Contract. If, during the progress of the work hereunder, the Contractor requests a reduction of such percentage, and the Project Manager determines that it would be to the client's advantage, the percentage of labor to be performed by the Contractor's own organization may be reduced; provided prior written approval of such reduction is obtained by the Contractor from the Project Manager.

17. TIME OF COMPLETION

The Bidder further agrees to begin work within twenty (20) calendar days after the date of the Notice to Proceed and to complete the construction of all items in the lump sum base Bid, in all respects, for this particular project, within one hundred twenty (120) calendar days after the date of the Notice to Proceed complete the project.

18. PAYMENT TERMS

The Contractor will bill the City on a monthly basis. Terms of payment will be a maximum of 45 days from receipt of invoice. The Contractor may bill the City on a more frequent basis if agreed upon by the Project Manager. The Contractor may also bill the City for materials on site once proof of delivery and storage is provided.

19. LICENSES, PERMITS, AND FEES

The Contractor is responsible for identifying, obtaining and paying for all licenses and permits from Federal, State, and Local agencies required to perform the work as stated in the sections of this Bid document. The licenses, permits, and fees that are required by the City of Key West are listed in Part 1: City of Key West Licenses, Permits, and Fees. The Contractor shall verify the list with the appropriate City of Key West Departments.

CITY OF KEY WEST LICENSES, PERMITS, AND FEES

Pursuant to the Public Bid Disclosure Act, each license, permit, or fee a Contractor will have to pay the City of Key West before or during construction or the percentage method or unit method of all licenses, permits, and fees **REQUIRED BY THE CITY OF KEY WEST** and payable to the City by virtue of this construction as part of the Contract is as follows:

- Key West, Business Tax Receipt – CGC or CBC: Fees not to exceed \$309.75
- Building Contractors License
- Building/Demolition Permit

Note: Contractor shall verify each license, permit, or fee before submitting the Bid.

LICENSES, PERMITS, AND FEES THAT MAY BE REQUIRED BY THE STATE OF FLORIDA, STATE AGENCIES, OR BY OTHER LOCAL GOVERNMENTAL ENTITIES ARE NOT INCLUDED IN THE ABOVE LIST.

Notice to Bidder: Use Black Ink or Type For Completing the Form.

BID

To: The City of Key West
Address: 3126 Flagler Ave, Key West, Florida 33040
Project Title: POLICE STATION WINDOWS REPLACEMENT
Project: ITB #13-003

BIDDER'S INFORMATION

Name: _____

Address: _____

Contact Name: _____

Email: _____

Telephone: _____

Fax: _____

Signature: _____ **Date:** _____

BIDDER'S DECLARATION AND UNDERSTANDING

The undersigned, hereinafter called the Bidder, declares that the only persons or parties interested in this Bid are those named herein, that this Bid is, in all respects, fair and without fraud, that it is made without collusion with any official of the Owner, and that the Bid is made without any connection or collusion with any person submitting another Bid on this Contract.

The Bidder further declares that he/she has carefully examined the Contract Documents for the construction of the project, that he/she has personally inspected the site, that he/she has satisfied himself/herself as to the quantities involved, including materials and equipment, and conditions of work involved, including the fact that the description of the quantities of work and materials, as included herein, is brief and is intended only to indicate the general nature of the work and to identify the said quantities with the detailed requirements of the Contract Documents, and that

this Bid is made according to the provisions and under the terms of the Contract Documents, which Documents are hereby made a part of this Bid.

The Bidder further agrees that he/she has exercised his/her own judgment regarding the interpretation of job conditions and has utilized all data, which he/she believes pertinent from the Project Manager, Owner, and other sources in arriving at his/her conclusions.

The intent of the Bid Documents is to describe a functionally complete project (or part thereof) to be constructed in accordance with the Contract Documents. Any work, materials, or equipment that may reasonably be inferred from the Contract Documents, as being required to produce the intended result shall be supplied whether or not specifically called for.

CONTRACT EXECUTION AND BONDS

The Bidder agrees that if this BID is accepted, he/she will, within ten (10) calendar days after Notice of Award, sign the Contract in the form annexed hereto, will attach all required licenses and certificates, and will, to the extent of his BID, furnish all equipment, materials, and labor necessary to complete all work as specified or indicated in the Contract Documents. Performance and Payment Bonds in an amount equal to 100% of contract value will be required as part of this contract.

CERTIFICATES OF INSURANCE

Bidder agrees to furnish the Owner, before commencing the work under this Contract, the certificates of insurance as specified in these Documents.

START OF CONSTRUCTION AND CONTRACT COMPLETION TIME

The Bidder further agrees to begin work within twenty (20) calendar days after the date of the Notice to Proceed and to complete the construction of all items in the lump sum base Bid, in all respects, for this particular project, within one hundred twenty (120) calendar days after the date of the Notice to Proceed.

LIQUIDATED DAMAGES

In the event the Bidder is awarded the Contract and shall fail to complete the work within the time limit or extended time limit agreed upon as more particularly set forth in the Contract Documents, liquidated damages shall be paid to the Owner at the rate of five hundred dollars (\$500.00) per day for all work awarded under this contract until the work has been satisfactorily completed as provided by the Contract Documents. Sundays and legal holidays shall be included in determining days in default.

ADDENDA

The Bidder hereby acknowledges that he has received Addenda No's. _____, _____, _____, _____, _____ (Bidder shall insert No. of each Addendum received) and agrees that all addenda issued

are hereby made part of the Contract Documents, and the Bidder further agrees that his Bid(s) includes all impacts resulting from said addenda.

SALES AND USE TAXES

The Bidder agrees that all federal, state, and local sales and use taxes are included in the stated Bid prices for the work.

PUBLIC ENTITY CRIMES

“A person or affiliate who has been placed on the convicted vendor list following a conviction for a public entity crime may not submit a Bid on a contract to provide any goods or services to a public entity, may not submit a Bid on a contract with a public entity for the construction or repair of a public building or public work, may not submit Bids on leases of real property to a public entity, may not be awarded or perform work as a contractor, supplier, subcontractor, or Contractor under a contract with any public entity and may not transact business with any public entity in excess of the threshold amount provided in Section 287.017, for CATEGORY TWO for a period of 36 months from the date of being placed on the convicted vendor list.”

LUMP SUM BASE BID

The Bidder agrees to accept as full payment for performance of the work as herein specified and shown on the Drawings (if any), the following lump sum. The Bidder agrees that the lump sum price represents a true measure of the design, labor, materials, and equipment required to perform the work, including all allowances for overhead and profit for each type and unit of work called for in these Contract Documents. The amounts shall be shown in both words and figures. In case of a discrepancy, the amount shown in words shall govern. Final lump sum payments will be adjusted based on actual units and unit prices.

BID FORM

ITB #13-003: POLICE STATION WINDOWS REPLACEMENT

LUMP SUM BASE BID PRICE

\$ _____

Bid Total in Words

BID ALTERNATIVES

Please indicate whether the Alternate is an addition or deduction from the Base Bid

ALTERNATE 1 (Total Dollar Addition/Deduction to Base Bid)

\$ _____

In Words

ALTERNATE 2 (Total Dollar Addition/Deduction to Base Bid)

\$ _____

In Words

ALTERNATE 3 (Total Dollar Addition/Deduction to Base Bid)

\$ _____

In Words

ALTERNATE 4 (Total Dollar Addition/Deduction to Base Bid)

\$ _____

In Words

BID BREAKDOWN*

The Bidder shall provide a schedule of values for all aspects of the project including mobilization/demobilization, labor and materials, permitting, etc. required or to be used for the project. The schedule of values shall be in sufficient detail to allow the owner to understand how the Bidder arrived at said Base Bid and Alternate Bid prices and shall become part of the contract for basis of payment. The City may ask for a more detailed schedule of values if one submitted is not sufficient.

***FINAL PAYMENT WILL BE BASED ON ACTUAL QUANTITIES MEASURED IN THE FIELD AND APPROVED BY CITY STAFF**

SUBCONTRACTORS

The Bidder further proposes that the following subcontracting firms or businesses will be awarded subcontracts for the following portions of the work in the event that the Bidder is awarded the Contract:

Portion of Work: _____

Name: _____

Address: _____

Portion of Work: _____

Name: _____

Address: _____

Portion of Work: _____

Name: _____

Address: _____

BIDDER

The name of the Bidder submitting this Bid is: _____

Doing business at _____

City _____ State _____ Zip _____

Telephone No. _____

This address is where all communications concerning this Bid shall be sent.

The names of the principal officers of the Corporation submitting this Bid, or of the Partnership, or of all persons interested in this Bid as Principals are as follows:

Name	Title
_____	_____
_____	_____
_____	_____

If Corporation

IN WITNESS WHEREOF the undersigned corporation has caused this instrument to be executed and its seal affixed by its duly authorized officers this _____ day of _____, 20__.

(SEAL)

Name of Corporation _____

By: _____

Title: _____

Attest: _____

Secretary

If Sole Proprietor or Partnership

IN WITNESS hereto the undersigned has set his/her/its hand this _____ day of _____, 20__.

Signature of Bidder _____

Title _____

FLORIDA BID BOND

BOND NO. _____

AMOUNT \$ _____

KNOW ALL MEN BY THESE PRESENTS, that

_____, hereinafter called the PRINCIPAL, and _____, a corporation duly organized under the laws of the State of _____ having its principal place of business at _____ in the State of _____ and authorized to do business in the State of Florida, as SURETY, are held firmly bound unto hereinafter called the Obligee, in the sum of _____ DOLLARS (\$ _____) for the payment for which we bind ourselves, our heirs, executors, administrators, successors, and assigns, jointly and severally, firmly by these presents..

THE CONDITION OF THIS BOND IS SUCH THAT:

WHEREAS, the PRINCIPAL is herewith submitting his or its Bid or Bid for:

POLICE STATION WINDOWS REPLACEMENT said Bid, by reference thereto, being hereby made a part hereof.

WHEREAS, the PRINCIPAL contemplates submitting or has submitted a Bid to the OBLIGEE for the furnishing of labor, materials, (except those specifically furnished by the Owner), equipment, machinery, tools, apparatus, means of transportation for, and the performance of the work covered in the Bid and the detailed Specifications entitled:

POLICE STATION WINDOWS REPLACEMENT

WHEREAS, it was a condition precedent to the submission of said Bid that a cashier's check, certified check, or Bid bond in the amount of five (5) percent of the base Bid be submitted with said Bid as a guarantee that the Bidder would, if awarded the Contract, enter into a written Contract with the Owner for the performance of said Contract, within five (5) working days after written notice having been given of the award of the Contract.

NOW, THEREFORE, the conditions of this obligation are such that if the PRINCIPAL within five (5) working days after written notice of such acceptance, enters into a written Contract with the OBLIGEE then this obligation shall be void: otherwise the sum herein stated shall be due and payable to the OBLIGEE and the Surety herein agrees to pay said sum immediately upon

demand of the OBLIGEE in good and lawful money of the United States of America, as liquidated damages for failure thereof of said principal.

Signed and sealed this _____ day of, _____ 20__.

PRINCIPAL

By

SURETY

Attorney-In-Fact

**SWORN STATEMENT UNDER SECTION 287.133(3)(a)
FLORIDA STATUTES, ON PUBLIC ENTITY CRIMES**

PROJECT ITB #13-003: POLICE STATION WINDOWS REPLACEMENT

THIS FORM MUST BE SIGNED IN THE PRESENCE OF A NOTARY PUBLIC OR OTHER OFFICE AUTHORIZED TO ADMINISTER OATHS.

1. This sworn statement is submitted with Bid, Bid or Contract No. _____ for _____

2. This sworn statement is submitted by _____
(Name of entity submitting sworn statement)

whose business address is _____
_____ and (if applicable) its Federal
Employer Identification Number (FEIN) is _____ (If the entity has no FEIN,
include the Social Security Number of the individual signing this sworn statement.)

3. My name is _____ and my relationship to
(Please print name of individual signing)

the entity named above is _____.

4. I understand that a "public entity crime" as defined in Paragraph 287.133(1)(g), Florida Statutes, means a violation of any state or federal law by a person with respect to and directly related to the transaction of business with any public entity or with an agency or political subdivision of any other state or with the United States, including but not limited to, any Bid or contract for goods or services to be provided to any public entity or an agency or political subdivision of any other state or of the United States and involving antitrust, fraud, theft, bribery, collusion, racketeering, conspiracy, material misrepresentation.

5. I understand that "convicted" or "conviction" as defined in Paragraph 287.133(1)(b), Florida Statutes, means a finding of guilt or a conviction of a public entity crime, with or without an adjudication of guilt, in any federal or state trial court of record relating to charges brought by indictment information after July 1, 1989, as a result of a jury verdict, nonjury trial, or entry of a plea of guilty or nolo contendere.

6. I understand that an "affiliate" as defined in Paragraph 287.133(1)(a), Florida Statutes, means
 1. A predecessor or successor of a person convicted of a public entity crime: or
 2. An entity under the control of any natural person who is active in the management of the entity and who has been convicted of a public entity crime. The term "affiliate" includes those officers, directors, executives, partners, shareholders, employees, members, and agents who are active in the management of an affiliate. The ownership by one person of shares constituting controlling interest in another person, or a pooling of equipment or income among persons when not for fair market value under an arm's length agreement, shall be a prima facie case that one person controls another person. A person who knowingly enters into a joint venture with a person who has been convicted of a public entity crime in Florida during the preceding 36 months shall be considered an affiliate.

7. I understand that a "person" as defined in Paragraph 287.133(1)(8), Florida Statutes, means any natural

person or entity organized under the laws of any state or of the United States with the legal power to enter into a binding contract and which Bids or applies to Bid on contracts for the provision of goods or services let by a public entity, or which otherwise transacts or applies to transact business with a public entity. The term "person" includes those officers, directors, executives, partners, shareholders, employees, members, and agents who are active in management of an entity.

8. Based on information and belief, the statement, which I have marked below, is true in relation to the entity submitting this sworn statement. (Please indicate which statement applies.)

___ Neither the entity submitting this sworn statement, nor any officers, directors, executives, partners, shareholders, employees, members, or agents who are active in management of the entity, nor any affiliate of the entity have been charged with and convicted of a public entity crime subsequent to July 1, 1989.

___ The entity submitting this sworn statement, or one or more of the officers, directors, executives, partners, shareholders, employees, members, or agents who are active in management of the entity, or an affiliate of the entity has been charged with and convicted of a public entity crime subsequent to July 1, 1989, AND (Please indicate which additional statement applies.)

___ There has been a proceeding concerning the conviction before a hearing of the State of Florida, Division of Administrative Hearings. The final order entered by the hearing officer did not place the person or affiliate on the convicted vendor list. (Please attach a copy of the final order.)

___ The person or affiliate was placed on the convicted vendor list. There has been a subsequent proceeding before a hearing officer of the State of Florida, Division of Administrative Hearings. The final order entered by the hearing officer determined that it was in the public interest to remove the person or affiliate from the convicted vendor list. (Please attach a copy of the final order.)

___ The person or affiliate has not been put on the convicted vendor list. (Please describe any action taken by or pending with the Department of General Services.)

(Signature)

(Date)

STATE OF _____

COUNTY OF _____

PERSONALLY APPEARED BEFORE ME, the undersigned authority,

_____ who, after first being sworn by me, affixed his/her signature in the
(Name of individual signing)

space provided above on this _____ day of _____, 20__.

My commission expires:

NOTARY PUBLIC

ANTI-KICKBACK AFFIDAVIT

PROJECT ITB #13-003: POLICE STATION WINDOWS REPLACEMENT

STATE OF _____)
: SS
COUNTY OF _____)

I, the undersigned hereby duly sworn, depose and say that no portion of the sum herein Bid will be paid to any employees of the City of Key West as a commission, kickback, reward or gift, directly or indirectly by me or any member of my firm or by an officer of the corporation.

By: _____

Sworn and subscribed before me this

_____ day of _____, 20__.

NOTARY PUBLIC, State of _____ at Large

My Commission Expires: _____

CITY OF KEY WEST INDEMNIFICATION FORM

To the fullest extent permitted by law, the Contractor expressly agrees to indemnify and hold harmless the City of Key West, their officers, directors, agents, and employees (herein called the “indemnities”) from liabilities, damages, losses and costs, including, but not limited to, reasonable attorney’s fees and court costs, such legal expenses to include costs incurred in establishing the indemnification and other rights agreed to in this Paragraph, to persons or property, to the extent caused by the negligence, recklessness, or intentional wrongful misconduct of the Contractor its Subcontractors or persons employed or utilized by them in the performance of the Contract. Claims by indemnities for indemnification shall be limited to the amount of Contractor’s insurance or \$1 million per occurrence, whichever is greater. The parties acknowledge that the amount of the indemnity required hereunder bears a reasonable commercial relationship to the Contract and it is part of the project specifications or the bid documents, if any.

The indemnification obligations under the Contract shall not be restricted in any way by any limitation on the amount or type of damages, compensation, or benefits payable by or for the Contractor under workers’ compensation acts, disability benefits acts, or other employee benefits acts, and shall extend to and include any actions brought by or in the name of any employee of the Contractor or of any third party to whom Contractor may subcontract a part or all of the Work. This indemnification shall continue beyond the date of completion of the work.

CONTRACTOR: _____

SEAL:

Address

Signature

Print Name

Title

Date

**LOCAL VENDOR CERTIFICATION PURSUANT TO CKW ORDINANCE 09-22
SECTION 2-798**

PROJECT ITB #13-003: POLICE STATION WINDOWS REPLACEMENT

The undersigned, as a duly authorized representative of the vendor listed herein, certifies to the best of his/her knowledge and belief, that the vendor meets the definition of a "Local Business." For purposes of this section, "local business" shall mean a business which:

- a. Principle address as registered with the FL Department of State located within 30 miles of the boundaries of the city, listed with the chief licensing official as having a business tax receipt with its principle address within 30 miles of the boundaries of the city for at least one year immediately prior to the issuance of the solicitation.
- b. Maintains a workforce of at least 50 percent of its employees from the city or within 30 miles of its boundaries.
- c. Having paid all current license taxes and any other fees due the city at least 24 hours prior to the publication of the call for bids or request for proposals.
 - Not a local vendor pursuant to Ordinance 09-22 Section 2-798
 - Qualifies as a local vendor pursuant to Ordinance 09-22 Section 2-798

If you qualify, please complete the following in support of the self certification & submit copies of your County and City business licenses. Failure to provide the information requested will result in denial of certification as a local business.

Business Name

Phone:

Current Local Address:

Fax:

(P.O Box numbers may not be used to establish status)

Length of time at this address

Signature of Authorized Representative

Date

STATE OF _____

COUNTY OF _____

The foregoing instrument was acknowledged before me this _____ day of _____, 20____.

By _____, of _____

(Name of officer or agent, title of officer or agent)

Name of corporation acknowledging)

or has produced _____ as identification

(type of identification)

Signature of Notary

Print, Type or Stamp Name of Notary

Return Completed form with
Supporting documents to:
City of Key West Purchasing

Title or Rank

EQUAL BENEFITS FOR DOMESTIC PARTNERS AFFIDAVIT

PROJECT ITB #13-003: POLICE STATION WINDOWS REPLACEMENT

STATE OF _____)
 : SS
COUNTY OF _____)

I, the undersigned hereby duly sworn, depose and say that the firm of _____ provides benefits to domestic partners of its employees on the same basis as it provides benefits to employees' spouses per City of Key West Ordinance Sec. 2-799.

By: _____

Sworn and subscribed before me this
_____ day of _____, 20__.

NOTARY PUBLIC, State of _____ at Large

My Commission Expires: _____

City Ordinance Sec. 2-799
Requirements for City Contractors to Provide Equal Benefits for Domestic Partners

- (a) Definitions. For purposes of this section only, the following definitions shall apply:
- (1) **Benefits** means the following plan, program or policy provided or offered by a contractor to its employees as part of the employer's total compensation package: sick leave, bereavement leave, family medical leave, and health benefits.
 - (2) **Bid** shall mean a competitive bid procedure established by the city through the issuance of an invitation to bid, request for proposals, request for qualifications, or request for letters of interest.
 - (3) **Cash equivalent** means the amount of money paid to an employee with a domestic partner in lieu of providing benefits to the employee's domestic partner. The cash equivalent is equal to the employer's direct expense of providing benefits to an employee for his or her spouse.

The cash equivalents of the following benefits apply:

- a. For bereavement leave, cash payment for the number of days that would be allowed as paid time off for the death of a spouse. Cash payment would be in the form of the wages of the domestic partner employee for the number of days allowed.
 - b. For health benefits, the cost to the contractor of the contractor's share of the single monthly premiums that are being paid for the domestic partner employee, to be paid on a regular basis while the domestic partner employee maintains such insurance in force for himself or herself.
 - c. For family medical leave, cash payment for the number of days that would be allowed as time off for an employee to care for a spouse who has a serious health condition. Cash payment would be in the form of the wages of the domestic partner employee for the number of days allowed.
- (4) **Contract** means any written agreement, purchase order, standing order or similar instrument entered into pursuant to the award of a bid whereby the city is committed to expend or does expend funds in return for work, labor, professional services, consulting services, supplies, equipment, materials, construction, construction related services or any combination of the foregoing.
 - (5) **Contractor** means any person or persons, sole proprietorship, partnership, joint venture, corporation, or other form of doing business, that is awarded a bid and enters into a covered contract with the city, and which maintains five (5) or more full-time employees.
 - (6) **Covered contract** means a contract between the city and a contractor awarded subsequent to the date when this section becomes effective valued at over twenty thousand dollars (\$20,000).
 - (7) **Domestic partner** shall mean any two adults of the same or different sex, who have registered as domestic partners with a governmental body pursuant to state or local law authorizing such registration, or with an internal registry maintained by the employer of at least one of the domestic partners. A contractor may institute an internal registry to allow for the provision of equal benefits to

employees with domestic partner who do not register their partnerships pursuant to a governmental body authorizing such registration, or who are located in a jurisdiction where no such governmental domestic partnership registry exists. A contractor that institutes such registry shall not impose criteria for registration that are more stringent than those required for domestic partnership registration by the City of Key West pursuant to Chapter 38, Article V of the Key West Code of Ordinances.

- (8) ***Equal benefits*** mean the equality of benefits between employees with spouses and employees with domestic partners, and/or between spouses of employees and domestic partners of employees.

(b) Equal benefits requirements.

- (1) Except where otherwise exempt or prohibited by law, a Contractor awarded a covered contract pursuant to a bid process shall provide benefits to domestic partners of its employees on the same basis as it provides benefits to employees' spouses.
- (2) All bid requests for covered contracts which are issued on or after the effective date of this section shall include the requirement to provide equal benefits in the procurement specifications in accordance with this section.
- (3) The city shall not enter into any covered contract unless the contractor certifies that such contractor does not discriminate in the provision of benefits between employees with domestic partners and employees with spouses and/or between the domestic partners and spouses of such employees.
- (4) Such certification shall be in writing and shall be signed by an authorized officer of the contractor and delivered, along with a description of the contractor's employee benefits plan, to the city's procurement director prior to entering into such covered contract.
- (5) The city manager or his/her designee shall reject a contractor's certification of compliance if he/she determines that such contractor discriminates in the provision of benefits or if the city manager or designee determines that the certification was created, or is being used for the purpose of evading the requirements of this section.
- (6) The contractor shall provide the city manager or his/her designee, access to its records for the purpose of audits and/or investigations to ascertain compliance with the provisions of this section, and upon request shall provide evidence that the contractor is in compliance with the provisions of this section upon each new bid, contract renewal, or when the city manager has received a complaint or has reason to believe the contractor may not be in compliance with the provisions of this section. This shall include but not be limited to providing the city manager or his/her designee with certified copies of all of the contractor's records pertaining to its benefits policies and its employment policies and practices.
- (7) The contractor may not set up or use its contracting entity for the purpose of evading the requirements imposed by this section.

(c) Mandatory contract provisions pertaining to equal benefits. Unless otherwise exempt, every covered contract shall contain language that obligates the contractor to comply with

the applicable provisions of this section. The language shall include provisions for the following:

- (1) During the performance of the covered contract, the contractor certifies and represents that it will comply with this section.
- (2) The failure of the contractor to comply with this section will be deemed to be a material breach of the covered contract.
- (3) If the contractor fails to comply with this section, the city may terminate the covered contract and all monies due or to become due under the covered contract may be retained by the city. The city may also pursue any and all other remedies at law or in equity for any breach.
- (4) If the city manager or his designee determines that a contractor has set up or used its contracting entity for the purpose of evading the requirements of this section, the city may terminate the covered contract.

(d) Enforcement. If the contractor fails to comply with the provisions of this section:

- (1) The failure to comply may be deemed to be a material breach of the covered contract; or
- (2) The city may terminate the covered contract; or
- (3) Monies due or to become due under the covered contract may be retained by the city until compliance is achieved; or
- (4) The city may also pursue any and all other remedies at law or in equity for any breach;
- (5) Failure to comply with this section may also subject contractor to the procedures set forth in Division 5 of this article, entitled "Debarment of contractors from city work."

(e) Exceptions and waivers.

The provisions of this section shall not apply where:

- (1) The contractor does not provide benefits to employees' spouses.
- (2) The contractor is a religious organization, association, society or any non-profit charitable or educational institution or organization operated, supervised or controlled by or in conjunction with a religious organization, association or society.
- (3) The contractor is a governmental entity.
- (4) The sale or lease of city property.
- (5) The provision of this section would violate grant requirement, the laws, rules or regulations of federal or state law (for example, The acquisition services procured pursuant to Chapter 287.055, Florida Statutes known as the "Contractors' Competitive Negotiation Act").
- (6) Provided that the contractor does not discriminate in the provision of benefits, a contractor may also comply with this section by providing an employee with the cash equivalent of such benefits, if the city manager or his/her designee determines that either:

- a. The contractor has made a reasonable yet unsuccessful effort to provide equal benefits. The contractor shall provide the city manager or his/her designee with sufficient proof of such inability to provide such benefit or benefits which shall include the measures taken to provide such benefits or benefits and the cash equivalent proposed, along with its certificate of compliance, as is required under this section.
- (7) The city commission waives compliance of this section in the best interest of the city, including but not limited to the following circumstances:
- a. The covered contract is necessary to respond to an emergency.
 - b. Where only one bid response is received.
 - c. Where more than one bid response is received, but the bids demonstrate that none of the bidders can comply with the requirements of this section.
- (f) City's authority to cancel contract. Nothing in this section shall be construed to limit the city's authority to cancel or terminate a contract, deny or withdraw approval to perform a subcontract or provide supplies, issue a non-responsibility finding, issue a non-responsiveness finding, deny a person or entity prequalification, or otherwise deny a person or entity city business.
- (g) Timing of application. This section shall be applicable only to covered contracts awarded pursuant to bids which are after the date when this section becomes effective.

PART 2

CONTRACT FORMS



Notice of Award

Date

Company

Attention:

Address

City, State, Zip

Project: POLICE STATION WINDOWS REPLACEMENT: ITB No: 13-003

Dear:

At a meeting of the Key West City Commission held on _____, 20__, your firm, _____ was awarded the contract for POLICE STATION WINDOWS REPLACEMENT for a total contract amount of \$_____.

Enclosed please find two (2) copies of the Contract Documents for your execution. Please complete the necessary pages, affixing signatures, notary and / or corporate seals, etc. where necessary and return to this office within ten (10) calendar days from the date of this letter.

The Certificate of Insurance must be attached to the documents; an original and two copies are acceptable. Please provide Performance and Payment Bonds in an amount equal to 100% of the contract value. Builders Risk is not required as part of this contract. The attached Performance and Payment Bonds boiler plates may be used or the Contractor may submit their own equivalent bond forms.

A copy of your City of Key West Business Tax Receipt must be attached.

If you have additional questions, please do not hesitate to call me at (305) 809-3792.

Sincerely,

Doug Bradshaw
Senior Project Manager

SAMPLE CONTRACT

This Contract, made and entered into this _____ day of _____ 20__, by and between the **CITY OF KEY WEST**, hereinafter called the "Owner", and _____, hereinafter called the "Contractor";

WITNESSETH:

The Contractor, in consideration of the sum to be paid him by the Owner and of the covenants and agreements herein contained, hereby agrees at his own proper cost and expense to do all the work and furnish all the materials, tools, labor, and all appliances, machinery, and appurtenances for the PROJECT ITB #13-003: POLICE STATION WINDOWS REPLACEMENT, to the extent of the BID made by the Contractor, dated this _____ day of _____ 20__, all in full compliance with the Contract Documents referred to herein:

BIDDING REQUIREMENTS, CONTRACT FORMS, CONDITIONS OF THE CONTRACT, TECHNICAL SPECIFICATIONS, AND DRAWINGS (if any), which consists of POLICE STATION WINDOWS REPLACEMENT are hereby referred to and by reference made a part of this Contract as fully and completely as if the same were fully set forth herein and are mutually cooperative therewith.

In consideration of the performance of the work as set forth in these Contract Documents, the Owner agrees to pay to the Contractor the LUMP SUM BID amount in the Bid as adjusted in accordance with the Contract Documents, or as otherwise herein provided, and to make such payments in the manner and at the times provided in the Contract Documents.

The Contractor agrees to complete the work within the time specified in the Contract, and to accept as full payment hereunder the amounts as determined by the Contract Documents and based on the said Bid.

The Contractor agrees to remedy all defects appearing in the work or developing in the materials furnished and the workmanship performed under this Contract during a two (2) year warranty period after the date of final acceptance of the work by the Owner, and further agrees to

indemnify and hold harmless the Owner from any costs encountered in remedying such defects.

The Bidder further agrees to begin work within twenty (20) calendar days after the date of the Notice to Proceed and to complete the construction of all items in the lump sum base Bid, in all respects, for this particular project, within one hundred twenty (120) calendar days after the date of the Notice to Proceed.

In the event that the Contractor shall fail to complete the work within the time limit or the extended time limit agreed upon, as more particularly set forth in the Contract Documents, liquidated damages shall be paid at the rate of five hundred dollars (\$500.00) per calendar day. Sundays and legal holidays shall be included in determining days in default.

IN WITNESS WHEREOF, we, the parties hereto, each herewith subscribe the same, this _____ day of _____ 20__.

Attest:

By:

Cheryl Smith, City Clerk

Bogdan Vitas, Jr., City Manager

Contractor: _____ Witness: _____

By: _____ Print Name: _____

Print Name: _____

Title: _____

PERFORMANCE BOND

BOND NO.
AMOUNT: \$

KNOW ALL MEN BY THESE PRESENTS, that in accordance with Florida Statutes Section 255.05, _____
with offices at _____
hereinafter called the CONTRACTOR (Principal), and

_____ with offices at _____
a corporation duly organized and existing under and by virtue of the laws of the State of Florida, hereinafter called the SURETY, and authorized to transact business within the State of Florida, as SURETY, are held and firmly bound unto **CITY OF KEY WEST**, represented by its _____, hereinafter called the CITY (Obligee), in the sum of:

_____ DOLLARS (\$_____), lawful money of the United States of America, for the payment of which, well and truly be made to the CITY, the CONTRACTOR and the SURETY bind themselves and each of their heirs, executors, administrators, successors, and assigns, jointly and severally, firmly by these presents as follows:

THE CONDITION OF THE ABOVE OBLIGATION IS SUCH THAT:

WHEREAS, the CONTRACTOR has executed and entered into a certain Contract hereto attached, with the CITY, dated _____, 20____, to furnish at his own cost, charges, and expense all the necessary materials, equipment, and/or labor in strict and express accordance with said Contract and the Contract Documents as defined therein, all of which is made a part of said Contract by certain terms and conditions in said Contract more particularly mentioned, which Contract, consisting of the various Contract Documents is made a part of this Bond as fully and completely as if said Contract Documents were set forth herein;

NOW THEREFORE, the conditions of this obligation are such that if the above bounden CONTRACTOR:

1. Shall in all respects comply with the terms and conditions of said Contract and his obligation there under, including the Contract Documents (which include the plans, drawings, specifications, and conditions as prepared by the CITY, invitation to bid, instructions to bidders, the CONTRACTOR’S bid as accepted by the above CITY, the bid and contract performance and payment bonds, and all addenda, if any, issued prior to the opening of bids), being made a part of this bond by reference, at the times and in the manner prescribed in the contract; and
2. Promptly makes payments to all claimants, as defined in Section 255.05(1), Florida Statutes, supplying PRINCIPAL with labor, materials, or supplies, used directly or indirectly by PRINCIPAL in the prosecution of the work provided for in the contract; and

3. Pays CITY all losses, costs, expenses, damages, attorney's fees, including appellate proceedings, injury or loss of whatever kind and however arising including, without limitation, delay damages to which said CITY may be subject by reason of any wrongdoing, misconduct, want of care or skill, negligence, failure of performance, breach, failure to petition within the prescribed time, or default, including patent infringements, on the part of said CONTRACTOR, his agents or employees, in the execution or performance of said Contract; and

4. Performs the guarantee of all work and materials furnished under the contract for the time specified in the contract, then this obligation shall be void; otherwise, to remain in full force and effect for the term of said Contract.

AND, the said Surety for value received, hereby stipulates and agrees that no change involving any extension of time, or addition to the terms of the Contract Documents, or to the work to be performed, or materials to be furnished there under shall affect said obligation of said Surety on this Bond, and the said Surety does hereby waive notice of any such changes, extension of time, alterations, or additions of the terms of the Contract Documents, or to the work.

Any action instituted by a claimant under this bond for payment must be in accordance with the notice and time limitation provisions in Section 255.05(2), Florida Statutes.

IN WITNESS WHEREOF, the above parties bonded together have executed this instrument this _____ day of _____, 20___, the name and corporate seal of each corporate party being hereto affixed and those presents duly signed by its undersigned representative, pursuant to authority of its governing body.

CONTRACTOR

By: _____

(SEAL)

ATTEST

SURETY

By: _____

(SEAL)

ATTEST

PAYMENT BOND

BOND NO.
AMOUNT: \$

KNOW ALL MEN BY THESE PRESENTS, that in accordance with Florida Statutes Section 255.05, _____

with offices at _____
hereinafter _____ called the CONTRACTOR, (Principal), and

_____ with offices at _____
a corporation duly organized and existing under and by virtue of the laws of the State of _____, hereinafter called the SURETY, and authorized to transact business within the State of Florida, as SURETY, are held and firmly bound CITY OF KEY WEST, represented by its _____, hereinafter called the City (Obligee), in the sum of: _____ DOLLARS (\$ _____), lawful money of the United States of America, for the payment of which, well and truly be made to the CITY, and the CONTRACTOR and the SURETY bind themselves and each of their heirs, executors, administrators, successors, and assigns, jointly and severally, firmly by these presents as follows:

THE CONDITION OF THE ABOVE OBLIGATION IS SUCH THAT:

WHEREAS, the CONTRACTOR has executed and entered into a certain Contract for _____ attached hereto, with the CITY, dated _____, 20_____, to furnish at his own cost, charges, and expense the necessary materials, equipment, and/or labor in strict and express accordance with said Contract and the plans, drawings (if any), and specifications prepared by the CITY, all of which is made a part of said Contract by certain terms and conditions in said Contract more particularly mentioned, which Contract, consisting of the various Contract Documents specifically mentioned herein and relative hereto, is made a part of this Bond as fully and completely as if said Contract Documents were set forth herein.

NOW THEREFORE, the conditions of this obligation are such that if the above bounden CONTRACTOR shall in all respects comply with the terms and conditions of said Contract and his obligation thereunder, including the Contract Documents (which include the plans, drawings, specifications, and conditions prepared by the CITY, invitation to bid, instructions to bidders, the CONTRACTOR’S bid as accepted by the CITY, the bid and contract and payment bonds, and all addenda, if any, issued prior to the opening of bids), and further that if said CONTRACTOR shall promptly make payments to all persons supplying materials, equipment, and/or labor, used directly or indirectly by said CONTRACTOR or subcontractors in the prosecution of the work for said contract in accordance with Florida Statutes, Section 255.05 or Section 713.23, then this obligation shall be void; otherwise to remain in full force and effect for the term of said contract, including and all guarantee periods as specifically mentioned in said Contract Documents.

AND, the said SURETY for value received, hereby stipulates and agrees that no change involving any extension of time, or addition to the terms of the Contract or to the work to be performed, or materials to be furnished thereunder, or in the Contract Documents and specifications accompanying the said contract shall affect said obligation of said SURETY on this Bond, and the said SURETY does hereby waive notice of any such changes, extension of time, alternations, or additions of the terms of the Contract, or to the work, to the Contract Documents, or to the specifications.

Claimant shall give written notice to the CONTRACTOR and the SURETY as required by Section 255.05 or Section 713.23, Florida Statutes. Any action instituted against the CONTRACTOR or SURETY under this bond for payment must be in accordance with the notice and time limitation provisions in Section 255.05(2) or Section 713.23, Florida Statutes.

IN WITNESS WHEREOF, the above parties bounded together have executed this instrument this _____ day of _____, 20____, the name and corporate seal of each corporate party being hereto affixed and those presents duly signed by its undersigned representative, pursuant to authority of its governing body.

CONTRACTOR

By: _____

(SEAL)

ATTEST

SURETY

By: _____

(SEAL)

ATTEST

SAMPLE INSURANCE FORMS

Memo

Subject: Contractor Insurance Requirements for the City of Key West, Florida

All contractors and subcontractors wishing to perform work for the City of Key West, Florida, will be required to comply with the following minimum insurance requirements:

Commercial General Liability Limits:	\$2,000,000 Aggregate \$1,000,000 Each Occurrence \$2,000,000 Products-Comp / Op Aggregate \$1,000,000 Personal & Advertising Injury \$300,000 Fire Damage / Legal
--------------------------------------	--

Coverage must include the following:

- | | |
|-----------------------------------|--|
| - Contractual Liability | - Commercial Form |
| - CG2010 (1185) or Equivalent | - Broad Form Property Damage |
| - No exclusion for XCU | - Premises / Operations |
| - Products / Completed Operations | - Independent Contractors (if any part of the work is to be subcontracted out) |
| - Personal Injury | |

Automobile Liability:	\$1,000,000 Combined Single Limit (Include Hired & Non-Owned Liability)
-----------------------	--

Additional Umbrella Liability:	\$_,000,000 Occurrence / Aggregate
--------------------------------	------------------------------------

Worker's Compensation:	Statutory
Employer's Liability:	\$1,000,000 Each Accident \$1,000,000 Disease-Policy Limit \$1,000,000 Disease-Each Employee

The above reflects the minimum requirements for working with the City of Key West. Any requirements found in a particular job's contract that are of a higher standard will prevail.

The City of Key West must be named as an additional insured under all policies other than worker's compensation. Contractor's or subcontractor's general liability shall be written on a primary and non-contributory basis. Certificates of insurance must be accompanied by a copy of the additional insured endorsement (CG 20101185 or combination of CG20100704 and CG20370704 will be accepted).

Contractors and subcontractors must obtain an endorsement from their carrier that waives and relinquishes any right of subrogation against the City of Key West and its agents, representatives, employees, and affiliates they might possess for any policy of insurance provided under this requirement or under any state or federal worker's compensation or employer's liability act.

Contractor's policies must be endorsed to give no less than thirty (30) days notice to the City in the event of material change or cancellation.

The City of Key West must be given a certificate of insurance showing that the above requirements have been met. The certificate of insurance must remain current and must include copies of the requested endorsements (additional insured, cancellation notice, and waiver of subrogation) in order for the City to issue payments to the contractor or subcontractor.

THIS CERTIFICATE IS ISSUED AS A MATTER OF INFORMATION ONLY AND CONFERS NO RIGHTS UPON THE CERTIFICATE HOLDER. THIS CERTIFICATE DOES NOT AFFIRMATIVELY OR NEGATIVELY AMEND, EXTEND OR ALTER THE COVERAGE AFFORDED BY THE POLICIES BELOW. THIS CERTIFICATE OF INSURANCE DOES NOT CONSTITUTE A CONTRACT BETWEEN THE ISSUING INSURER(S), AUTHORIZED REPRESENTATIVE OR PRODUCER, AND THE CERTIFICATE HOLDER.

IMPORTANT: If the certificate holder is an **ADDITIONAL INSURED**, the policy(ies) must be endorsed. If **SUBROGATION IS WAIVED**, subject to the terms and conditions of the policy, certain policies may require an endorsement. A statement on this certificate does not confer rights to the certificate holder in lieu of such endorsement(s).

PRODUCER	CONTACT NAME:	
	PHONE (A/C, No, Ext):	FAX (A/C, No):
	E-MAIL ADDRESS:	
	INSURER(S) AFFORDING COVERAGE	
INSURED Contractor Sample	INSURER A:	NAIC #
	INSURER B:	
	INSURER C:	
	INSURER D:	
	INSURER E:	
	INSURER F:	

COVERAGES

CERTIFICATE NUMBER:

REVISION NUMBER:

THIS IS TO CERTIFY THAT THE POLICIES OF INSURANCE LISTED BELOW HAVE BEEN ISSUED TO THE INSURED NAMED ABOVE FOR THE POLICY PERIOD INDICATED. NOTWITHSTANDING ANY REQUIREMENT, TERM OR CONDITION OF ANY CONTRACT OR OTHER DOCUMENT WITH RESPECT TO WHICH THIS CERTIFICATE MAY BE ISSUED OR MAY PERTAIN, THE INSURANCE AFFORDED BY THE POLICIES DESCRIBED HEREIN IS SUBJECT TO ALL THE TERMS EXCLUSIONS AND CONDITIONS OF SUCH POLICIES. LIMITS SHOWN MAY HAVE BEEN REDUCED BY PAID CLAIMS.

INSR LTR	TYPE OF INSURANCE	ADDL INSR	SUBR WVD	POLICY NUMBER	POLICY EFF (MM/DD/YYYY)	POLICY EXP (MM/DD/YYYY)	LIMITS	
	GENERAL LIABILITY <input checked="" type="checkbox"/> COMMERCIAL GENERAL LIABILITY <input type="checkbox"/> CLAIMS-MADE <input checked="" type="checkbox"/> OCCUR	X	X				EACH OCCURRENCE	\$1,000,000
							DAMAGE TO RENTED PREMISES (Ea occurrence)	\$300,000
							MED EXP (Any one person)	\$
							PERSONAL & ADV INJURY	\$1,000,000
							GENERAL AGGREGATE	\$2,000,000
							PRODUCTS - COMP/OP AGG	\$2,000,000
								\$
	AUTOMOBILE LIABILITY <input checked="" type="checkbox"/> ANY AUTO <input type="checkbox"/> ALL OWNED AUTOS <input checked="" type="checkbox"/> HIRED AUTOS <input type="checkbox"/> SCHEDULED AUTOS <input checked="" type="checkbox"/> HIGH-OWNED AUTOS	X	X				COMBINED SINGLE LIMIT (Ea accident)	\$1,000,000
							BODILY INJURY (Per person)	\$
							BODILY INJURY (Per accident)	\$
							PROPERTY DAMAGE (Per accident)	\$
								\$
	<input checked="" type="checkbox"/> UMBRELLA LIAB <input checked="" type="checkbox"/> OCCUR <input type="checkbox"/> EXCESS LIAB <input type="checkbox"/> CLAIMS-MADE <input type="checkbox"/> DED <input checked="" type="checkbox"/> RETENTION \$	X	X				EACH OCCURRENCE	\$,000,000
							AGGREGATE	\$,000,000
								\$
	WORKERS COMPENSATION AND EMPLOYERS' LIABILITY ANY PROPRIETOR/PARTNER/EXECUTIVE OFFICER/MEMBER EXCLUDED? (Mandatory in NH) If yes, describe under DESCRIPTION OF OPERATIONS below	N/A	X				<input checked="" type="checkbox"/> WC STATUTORY LIMITS	OTHER
							E.L. EACH ACCIDENT	\$1,000,000
							E.L. DISEASE - EA EMPLOYEE	\$1,000,000
							E.L. DISEASE - POLICY LIMIT	\$1,000,000

DESCRIPTION OF OPERATIONS / LOCATIONS / VEHICLES (Attach ACORD 101, Additional Remarks Schedule, if more space is required)

CERTIFICATE HOLDER**CANCELLATION**

City of Key West
P.O. Box 1409
Key West, FL 33041-1409

SHOULD ANY OF THE ABOVE DESCRIBED POLICIES BE CANCELLED BEFORE THE EXPIRATION DATE THEREOF, NOTICE WILL BE DELIVERED IN ACCORDANCE WITH THE POLICY PROVISIONS.

AUTHORIZED REPRESENTATIVE

THIS ENDORSEMENT CHANGES THE POLICY. PLEASE READ IT CAREFULLY.

**ADDITIONAL INSURED – OWNERS, LESSEES OR
CONTRACTORS – SCHEDULED PERSON OR
ORGANIZATION**

This endorsement modifies insurance provided under the following:

COMMERCIAL GENERAL LIABILITY COVERAGE PART

SCHEDULE

Name Of Additional Insured Person(s) Or Organization(s):	Location(s) Of Covered Operations
Information required to complete this Schedule, if not shown above, will be shown in the Declarations.	

A. Section II – Who Is An Insured is amended to include as an additional insured the person(s) or organization(s) shown in the Schedule, but only with respect to liability for "bodily injury", "property damage" or "personal and advertising injury" caused, in whole or in part, by:

1. Your acts or omissions; or
2. The acts or omissions of those acting on your behalf,

in the performance of your ongoing operations for the additional insured(s) at the location(s) designated above.

B. With respect to the insurance afforded to these additional insureds, the following additional exclusions apply:

This insurance does not apply to "bodily injury" or "property damage" occurring after:

1. All work, including materials, parts or equipment furnished in connection with such work, on the project (other than service, maintenance or repairs) to be performed by or on behalf of the additional insured(s) at the location of the covered operations has been completed; or
2. That portion of "your work" out of which the injury or damage arises has been put to its intended use by any person or organization other than another contractor or subcontractor engaged in performing operations for a principal as a part of the same project.

POLICY NUMBER:

COMMERCIAL GENERAL LIABILITY
CG 20 37 07 04

THIS ENDORSEMENT CHANGES THE POLICY. PLEASE READ IT CAREFULLY.

ADDITIONAL INSURED – OWNERS, LESSEES OR CONTRACTORS – COMPLETED OPERATIONS

This endorsement modifies insurance provided under the following:

COMMERCIAL GENERAL LIABILITY COVERAGE PART

SCHEDULE

Name Of Additional Insured Person(s) Or Organization(s):	Location And Description Of Completed Operations

Information required to complete this Schedule, if not shown above, will be shown in the Declarations.

Section II – Who Is An Insured is amended to include as an additional insured the person(s) or organization(s) shown in the Schedule, but only with respect to liability for "bodily injury" or "property damage" caused, in whole or in part, by "your work" at the location designated and described in the schedule of this endorsement performed for that additional insured and included in the "products-completed operations hazard".

THIS ENDORSEMENT CHANGES THE POLICY. PLEASE READ IT CAREFULLY.

**EARLIER NOTICE OF CANCELLATION
PROVIDED BY US**

Number of Days Notice 30

For any statutorily permitted reason other than nonpayment of premium, the number of days required for notice of cancellation is increased to the number of days shown in the Schedule above.

If this policy is cancelled by us we will send the Named Insured and any party listed in the following schedule notice of cancellation based on the number of days notice shown above.

Schedule

Name of Person or Organization

Mailing Address

POLICY NUMBER:

COMMERCIAL GENERAL LIABILITY
CG 24 04 05 09

WAIVER OF TRANSFER OF RIGHTS OF RECOVERY AGAINST OTHERS TO US

This endorsement modifies insurance provided under the following:

COMMERCIAL GENERAL LIABILITY COVERAGE PART
PRODUCTS/COMPLETED OPERATIONS LIABILITY COVERAGE PART

SCHEDULE

Name Of Person Or Organization:

Information required to complete this Schedule, if not shown above, will be shown in the Declarations.

The following is added to Paragraph 8. Transfer Of Rights Of Recovery Against Others To Us of Section IV – Conditions:

We waive any right of recovery we may have against the person or organization shown in the Schedule above because of payments we make for injury or damage arising out of your ongoing operations or "your work" done under a contract with that person or organization and included in the "products-completed operations hazard". This waiver applies only to the person or organization shown in the Schedule above.

WAIVER OF OUR RIGHT TO RECOVER FROM OTHERS ENDORSEMENT

We have the right to recover our payments from anyone liable for an injury covered by this policy. We will not enforce our right against the person or organization named in the Schedule. (This agreement applies only to the extent that you perform work under a written contract that requires you to obtain this agreement from us.)

This agreement shall not operate directly or indirectly to benefit anyone not named in the Schedule.

Schedule

This endorsement changes the policy to which it is attached and is effective on the date issued unless otherwise stated.

(The information below is required only when this endorsement is issued subsequent to preparation of the policy.)

Endorsement Insured	Effective Policy No.	Endorsement No. Premium
Insurance Company	Countersigned by _____	

WC 00 03 13
(Ed. 4-84)

NOTICE TO PROCEED

Date

Company
Attention:
Address
City, State, Zip

Project: POLICE STATION WINDOWS REPLACEMENT: ITB NO: 13-003

You are hereby notified to commence work on _____, 20__ in accordance with the Contract made with the City of Key West on the _____ day of _____ 20__. The work shall be completed within one hundred twenty days (120) from the above date.

Sincerely,

Doug Bradshaw
Senior Project Manager

Receipt of this NOTICE TO PROCEED is hereby acknowledged this, the _____ day of _____, 20__.

CONTRACTOR: _____

By: _____

Title: _____

Date: _____

Please return one (1) copy of this notice to:

Doug Bradshaw, Sr Project Manager
City of Key West-Engineering
3140 Flagler Ave
Key West, FL 33040

PART 3
CONDITIONS

CONDITIONS OF BID
CITY OF KEY WEST

1. PREPARATION OF BIDS:

Bids will be prepared in accordance with the following:

- a. The enclosed Bid Response Form is to be used, other forms may be rejected.
- b. All information required by the Bid form shall be furnished. The BIDDER shall print or type his/her name and manually sign the Bid Response Form plus each continuation sheet on which an entry is made.
- c. Bid delivery time must be shown and shall include Sundays and holidays.
- d. BIDDER shall thoroughly examine the specifications, drawings, schedule, instructions, and all other contract documents.
- e. All Bids shall be submitted in original plus one copy and 2 CDs or flash drives containing the complete Bid in PDF format.
- f. BIDDERS are advised that all CITY OF KEY WEST contracts are subject to all legal requirements provided for in City ordinances and/or State and Federal Statutes.

2. DESCRIPTION OF SUPPLIES:

- a. Any manufacturer's name, trade name, brand name, or catalog number used in the specifications is for the purpose of describing and establishing general quality levels. SUCH REFERENCES ARE NOT INTENDED TO BE RESTRICTIVE. Bids will be considered for any brand, which meets the quality of the specifications for any item.

3. SUBMISSION OF BIDS:

- a. Bids and changes thereto shall be enclosed in sealed envelopes addressed to the City Clerk, City of Key West. The name and address of the BIDDER, the date and hour of the Bid opening and the Bid number shall be placed on the outside of the envelope.
- b. Bids must be submitted on the form furnished. Telecopy Bids will not be considered.
- c. Unless otherwise indicated, all City of Key West Bids may be awarded on a line-item basis.
- d. Bid prices must remain in effect for ordering up to three (3) months from Bid opening date.

4. REJECTION OF BIDS:

- a. The CITY OF KEY WEST may reject Bids for any and/or all of the following reasons: (1) for budgetary reasons, (2) if the BIDDER misstates or conceals a material fact in his/her Bid, (3) if the Bid does not strictly conform to the law or is non-responsive to the Bid requirements, (4) if the Bid is conditional, or (5) if a change of circumstances occurs making the purpose of the Bid unnecessary to the CITY OF KEY WEST. The CITY OF KEY WEST may also waive any minor informalities or irregularities in any Bid.

5. WITHDRAWAL OF BIDS:

- a. Bids may not be withdrawn after the time set for the Bid opening for a period of time as specified in the Instruction to BIDDERS.
- b. Bids may be withdrawn prior to the time set for Bids opening. Such request must be in writing addressed to the City Clerk.

6. LATE BIDS OR MODIFICATION:

- a. Bids and modifications received after the time set for the Bid opening will not be considered.
- b. Modifications in writing received prior to the time set for the Bid opening will be accepted.

7. LOCAL, STATE, AND FEDERAL COMPLIANCE REQUIREMENTS:

- a. BIDDERS shall comply with all local, state and federal directives, orders and laws as applicable to this Bid and subsequent contract(s) including, but not limited to:
 - 1. Equal Employment Opportunity (EEO), in compliance with Executive Order 11246, as applicable to this contract.
 - 2. Minority Business Enterprises (MBE), as applicable to this contract.
 - 3. Occupational Safety and Health Act (OSHA), as applicable to this contract.

8. COLLUSION:

- a. The BIDDER by affixing his/her signature to this Invitation to Bid, agrees to the following: "BIDDER certifies that his/her Bid is made without previous understanding, agreement, or connection with any person, firm, or corporation making a Bid for the same items and is in all respects fair, without outside control, collusion, fraud, or otherwise illegal action".

9. VARIANCE IN CONDITIONS:

- a. Any and all special conditions and specifications attached hereto, which vary from General Conditions, shall have precedence.

10. APPROPRIATIONS CLAUSE:

- a. If the contract or delivery extends beyond the current fiscal year, which ends on September 30, the contract shall be contingent upon the availability of funds appropriated for such purposes in the City's annual budget for the next succeeding fiscal year.

11. CLARIFICATION OR OBJECTION TO BID SPECIFICATIONS:

- a. If any person contemplating submitting a Bid for this contract is in doubt as to the true meaning of the specifications or other Bid documents or any part thereof, he/she may submit to the Finance Director on or before ten calendar (10) days prior to scheduled opening a request for clarification. All such requests for information shall be made in writing and the person submitting the request will be responsible for prompt delivery. Any interpretation of the Bid, if made, will be made only by

Addendum duly issued. Such addendum will be made available through the DEMANDSTAR web site. The City will not be responsible for any other explanation or interpretation of the proposed Bid made or given prior to the award of the contract.

12. DISCOUNTS:

- a. BIDDERS may offer a cash discount for prompt payment; however, such discount shall not be considered in determining the lowest net cost for Bid evaluation proposed. BIDDERS are encouraged to reflect cash discounts in the unit price quoted.
- b. In connection with any discount offered, time will be computed from the date of receipt of supplies or services or from the date a correct invoice is received, whichever is the later date. Payment is deemed to be made on the date of mailing of the check.

13. AWARD OF CONTRACT:

- a. The contract will be awarded to the lowest responsive and responsible BIDDER whose Bid, conforming to the Request for Bid, is most advantageous to the City, prices and other factors considered.
- b. The City reserves the right to accept and award item by item, and/or by group or in the aggregate, unless the BIDDER qualifies his/her Bid by specified limitations as provided in four (4).
- c. If two (2) or more Bids received are for the same total amount or unit price, quality and service being equal, the contract will be awarded according to City Ordinance Section 2-835(c).
- d. Prices quoted must be f.o.b. Key West, Florida, with all transportation charges prepaid unless otherwise specified in the Invitation to Bid.
- e. A written award of acceptance (Purchase Order) and a signed contract, mailed or otherwise furnished to the successful BIDDER shall result in a binding contract without further action by either party.

14. LOCAL PREFERENCE:

- a. Pursuant to City Code Section 2-798 the City of Key West policy of local preference is applied to Bids submitted by qualified local businesses.

15. DAMAGE:

- a. Successful BIDDER(s) will be responsible for making any and all claims against carriers for missing or damaged items.

16. SURETY AND INSURER QUALIFICATIONS

All bonds, insurance contracts, and certificates of insurance shall be either executed by or countersigned by a licensed resident agent of the surety or insurance company, having his/her place of business in the State of Florida, and in all ways complying with the insurance laws of the State of Florida. Further, the said surety or insurance company shall be duly licensed and qualified to do business in the State of Florida.

**GENERAL CONDITIONS
TABLE OF CONTENTS**

Article

DEFINITIONS

1. AS APPROVED
2. AS SHOWN, AND AS INDICATED
3. BIDDER
4. CONTRACT DOCUMENTS
5. CONTRACTOR
6. CONTRACT COMPLETION
7. DAYS
8. DRAWINGS
9. ENGINEER
10. NOTICE
11. OR EQUAL
12. OWNER
13. PLANS
14. SPECIFICATIONS
15. NOTICE TO PROCEED
16. SUBSTANTIAL COMPLETION
17. WORK

CONTRACT DOCUMENTS

18. INTENT OF CONTRACT DOCUMENTS
19. DISCREPANCIES & OMISSIONS
20. CHANGES IN THE WORK
21. EXAMINATIONS AND VERIFICATION OF CONTRACT DOCUMENTS
22. DOCUMENTS TO BE KEPT ON THE JOBSITE
23. ADDITIONAL CONTRACT DOCUMENTS
24. OWNERSHIP OF CONTRACT DOCUMENTS

THE ENGINEER

25. AUTHORITY OF THE ENGINEER
26. DUTIES & RESPONSIBILITIES OF THE ENGINEER
27. LIMITATIONS ON ENGINEER'S RESPONSIBILITIES
28. REJECTED WORK
29. LINES AND GRADES
30. SUBMITTALS
31. DETAIL DRAWINGS AND

Article

INSTRUCTIONS

THE CONTRACTOR & HIS EMPLOYEES

32. CONTRACTOR, AN INDEPENDENT AGENT
- 32 (a). ASSIGNMENT OF CONTRACT
33. SUBCONTRACTING
34. INSURANCE AND LIABILITY
 - A. GENERAL
 - B. CONTRACTOR & SUBCONTRACTOR INSURANCE
 - C. COMPENSATION & EMPLOYER'S LIABILITY INSURANCE
 - D. GENERAL LIABILITY INSURANCE (INCLUDING AUTOMOBILE)
 - E. BUILDERS RISK ALL RISK INSURANCE
 - F. NO PERSONAL LIABILITY OF PUBLIC OFFICIALS
 - G. SURETY AND INSURER QUALIFICATIONS
35. INDEMNITY
36. EXCLUSION OF CONTRACTOR CLAIMS
37. TAXES AND CHARGES
38. REQUIREMENTS OF STATE LAW FOR PUBLIC WORKS PROJECTS
39. CODES, ORDINANCES, PERMITS, AND LICENSES
40. SUPERINTENDENCE
- 40(a). CONTRACTOR'S RESPONSIBILITIES
41. RECEPTION OF ENGINEER'S COMMUNICATIONS
42. SAFETY
43. PROTECTION OF WORK AND PROPERTY
- 43(a). HISTORIC PRESERVATION
44. RESPONSIBILITY OF CONTRACTOR TO ACT IN AN EMERGENCY
45. MATERIALS AND APPLIANCES
46. CONTRACTORS' AND MANUFACTURERS' COMPLIANCE WITH STATE SAFETY, OSHA, AND OTHER CODE REQUIREMENTS
47. SUBSTITUTION OF MATERIALS
48. TESTS, SAMPLES, AND OBSERVATIONS
49. ROYALTIES AND PATENTS
50. CONTRACTOR'S RIGHT TO TERMINATE CONTRACT
51. CORRECTION OF DEFECTIVE WORK DURING WARRANTY PERIOD

Article

PROGRESS OF THE WORK

- 52. BEGINNING OF THE WORK
- 53. SCHEDULES AND PROGRESS REPORTS
- 54. PROSECUTION OF THE WORK
- 55. OWNER'S RIGHT TO RETAIN IMPERFECT WORK
- 55(a). OWNER'S RIGHT TO STOP WORK
- 56. OWNER'S RIGHT TO DO WORK
- 57. OWNER'S RIGHT TO TRANSFER EMPLOYMENT
- 58. DELAYS AND EXTENSIONS OF TIME
- 59. DIFFERING SITE CONDITION
- 60. LIQUIDATED DAMAGES
- 61. OTHER CONTRACTS
- 62. USE OF PREMISES
- 63. SUBSTANTIAL COMPLETION DATE
- 64. PERFORMANCE TESTING
- 65. OWNER'S USE OF PORTION OF THE WORK
- 66. CUTTING AND PATCHING
- 67. CLEANING UP

Article

PAYMENT

- 68. PAYMENT FOR CHANGE ORDERS
 - A. UNIT PRICE
 - B. LUMP SUM
 - C. COST REIMBURSEMENT WORK
- 69. PARTIAL PAYMENTS
 - A. GENERAL
 - B. ESTIMATE
 - C. DEDUCTION FROM ESTIMATE
 - D. QUALIFICATIONS FOR PARTIAL PAYMENT FOR MATERIALS DELIVERED
 - E. PAYMENT
- 70. CLAIMS FOR EXTRA WORK
- 71. RELEASE OF LIENS OR CLAIMS
- 72. FINAL PAYMENT
- 73. NO WAIVER OF RIGHTS
- 74. ACCEPTANCE OF FINAL PAYMENT CONSTITUTES RELEASE

DEFINITIONS

Whenever in the Contract Documents the following terms are used, the intent and meaning shall be interpreted as follows:

1. AS APPROVED

The words "as approved", unless otherwise qualified, shall be understood to be followed by the words "by the Engineer for conformance with the Contract Document".

2. AS SHOWN, AND AS INDICATED

The words "as shown" and "as Indicated" shall be understood to be followed by the words "on the Drawings".

3. BIDDER

The person or persons, partnership, firm, or corporation submitting a Bid for the work contemplated.

4. CONTRACT DOCUMENTS

The "Contract Documents" consist of the Bid Requirements, Contract Forms, Conditions of the Contract, Specifications, Drawings, all modifications thereof incorporated into the Documents before their execution, Change Orders, and all other requirements incorporated by specific reference thereto. These form the Contract.

5. CONTRACTOR

The person or persons, partnership, firm, or corporation who enters into the Contract awarded him by the Owner.

6. CONTRACT COMPLETION

The "Contract Completion" is the date the Owner accepts the entire work as being in compliance with the Contract Documents, or formally waives nonconforming work to extent of nonconformity, and issues the final payment in accordance with the requirements set forth in Article, "Final Payment" of these General Conditions.

7. DAYS

Unless otherwise specifically stated, the term "days" will be understood to mean calendar days. Business day or working day means any day other than Saturday, Sunday, or legal holiday.

8. DRAWINGS

The term "Drawings" refers to the official Drawings, profiles, cross sections, elevations, details, and other working drawings and supplementary drawings, or reproductions thereof which shows the location, character, dimensions, and details of the work to be performed.

9. ENGINEER

The person or organization identified as such in the Contract Documents. The Term "Engineer" means the Owner's Engineer, Owner's contracted Engineer, or its authorized representative.

9(a). PROJECT MANAGER

The person or organization identified as such in the Contract Documents. The Term "Project Manager" means the Owner's authorized representative overseeing the project for the City.

10. NOTICE

The term "notice" or the requirement to notify, as used in the Contract Documents or applicable state or federal statutes, shall signify a written communication delivered in person or by registered mail to the individual, or to a member of the firm, or to an officer of the corporation for whom it is intended. Certified or registered mail shall be addressed to the last business address known to him who gives the notice.

11. OR EQUAL

The term "or equal" shall be understood to indicate that the "equal" product is equivalent to or better than the product named in function, performance, reliability, quality, and general configuration. The Engineer will make determination of equality in reference to the project design requirements. Such equal products shall not be purchased or installed by the Contractor without written authorization.

12. OWNER

The person, organization, or public body identified as such in the Contract Documents.

Wherever in these Documents the word "Owner" appears, it shall be understood to mean the City of Key West whose address is 3140 Flagler Ave, Key West, Florida 33040.

13. PLANS (See Drawings)

14. SPECIFICATIONS

The term "Specifications" refers to those portions of the Contract Documents consisting of written technical descriptions of materials, equipment, construction systems, standards, and workmanship as applied to the work and certain administrative details applicable thereto. Where standard specifications, such as those of ASTM, AASHTO, etc., have been referred to, the applicable portions of such standard specifications shall become a part of these Contract Documents. If referenced specifications conflict with specifications contained herein, the requirements contained herein shall prevail.

FEDERAL, STATE, COUNTY, AND LOCAL STANDARD SPECIFICATIONS

Where portions of the work traverse or cross federal, state, county, or local highways, roads, or streets, and the agency in control of such property has established standard specifications governing items of work that differ from these Specifications, the most stringent requirements shall apply.

The Contractor shall comply with all regulations and requirements of the State Highway Department and the County Road Department wherever the work traverses or crosses state or county highways.

15. NOTICE TO PROCEED

A written notice given by the Owner to the Contractor (with a copy to the Engineer) fixing the date on which the Contract time will commence to run and on which the Contractor shall start to perform his obligation under the Contract Documents. The Owner will give the Notice to Proceed within thirty (30) calendar days following the execution of the Contract.

16. SUBSTANTIAL COMPLETION

"Substantial Completion" shall be that degree of completion of the project or a defined portion of the project, as evidenced by the Engineer's written notice of Substantial Completion, sufficient to provide the Owner, at his discretion, the full-time use of the project or defined portion of the project for the purposes for which it was intended. "Substantial Completion" of an operating facility shall be that degree of completion that has provided a minimum of seven (7) continuous days of successful, trouble-free, operation, which period shall begin after all performance and acceptance testing has been successfully demonstrated to the Engineer. All equipment contained in the work, plus all other components necessary to enable the Owner to operate the facility in a manner that was intended, shall be complete on the substantial completion date.

17. WORK

The word "work" within these Contract Documents shall include all material, labor, tools, and all appliances, machinery, transportation, and appurtenances necessary to perform and complete the Contract, and such additional items not specifically indicated or described which can be reasonably inferred as belonging to the item described or indicated and as required by good practice to provide a complete and satisfactory system or structure. As used herein, "provide" shall be understood to mean, "furnish and install, complete in-place".

CONTRACT DOCUMENTS

18. INTENT OF CONTRACT DOCUMENTS

The Contract Documents are complementary, and what is called for by one shall be as binding as if called for by all. The intent of the Documents is to describe a functionally complete project (or part thereof) to be constructed in accordance with the Contract Documents. Any work, materials, or equipment that may reasonably be inferred from the Contract Documents, as being required to produce the intended result shall be supplied whether or not specifically called for. When words, which have a well-known technical or

trade meaning, are used to describe work, materials, or equipment, such words shall be interpreted in accordance with that meaning.

Reference to standard specifications, manuals, or codes of any technical society, organization or association, or to the laws or regulations of any governmental authority, whether such reference be specific or by implication, shall mean the latest standard specification, manual, code or laws or regulations in effect on the first published date of the Invitation to Bid, except as may be otherwise specifically stated. However, no provision of any referenced standard specification, manual or code (whether or not specifically incorporated by reference in the Contract Documents) shall be effective to change the duties and responsibilities of Owner, Contractor, or Engineer, or any of their Contractors, agents, or employees from those set forth in the Contract Documents, nor shall it be effective to assign to Engineer, or any Engineer's Contractors, agents, or employees, any duty or authority to supervise or direct the furnishing or performance of the work or any duty or authority to undertake responsibility contrary to the provisions of Article LIMITATIONS ON ENGINEER'S RESPONSIBILITIES.

19. DISCREPANCIES AND OMISSIONS

Any discrepancies or omissions found in the Contract Documents shall be reported to the Engineer immediately. The Engineer will clarify discrepancies or omissions, in writing, within a reasonable time.

In resolving inconsistencies among two or more sections of the Contract Documents, precedence shall be given in the following order:

- A. CONTRACT
- B. BID
- C. CRITERION FOR POLICE STATION WINDOWS REPLACEMENT
- D. SPECIAL CONDITIONS
- E. SUPPLEMENTARY CONDITIONS
- F. REQUEST FOR BIDS
- G. INSTRUCTIONS TO BIDDERS
- H. GENERAL CONDITIONS
- I. SPECIFICATIONS
- J. DRAWINGS

Addenda shall take precedence over all sections referenced therein. Figure dimensions on Drawings shall take precedence over scale dimensions. Detailed Drawings shall take precedence over general Drawings.

20. CHANGES IN THE WORK

The Owner, without notice to the Sureties and without invalidating the Contract, may order changes in the work within the general scope of the Contract by altering, adding to, or

deducting from the work, the Contract being adjusted accordingly. All such work shall be executed under the conditions of the original Contract, except as specifically adjusted at the time of ordering such change.

In giving instructions, the Engineer may order minor changes in the work not involving extra cost and not inconsistent with the purposes of the project, but otherwise, except in an emergency endangering life and property, additions or deductions from the work shall be performed only in pursuance of an approved Change Order from the Owner, countersigned by the Engineer.

If the work is reduced by alterations, such action shall not constitute a claim for damages based on loss of anticipated profits.

21. EXAMINATIONS AND VERIFICATION OF CONTRACT DOCUMENTS

The Contractor shall thoroughly examine and become familiar with all of the various parts of these Contract Documents and determine the nature and location of the work, the general and local conditions, and all other matters, which can in any way affect the work under this Contract. Failure to make an examination necessary for this determination shall not release the Contractor from the obligations of this Contract. No verbal agreement or conversation with any officer, agent, or employee of the Owner, or with the Engineer either before or after the execution of this Contract, shall affect or modify any of the terms or obligations herein contained.

22. DOCUMENTS TO BE KEPT ON THE JOBSITE

The Contractor shall keep one copy of the Contract Documents on the job- site, in good order, available to the Engineer and to his/her representatives.

The Contractor shall maintain on a daily basis at the jobsite, and make available to the Engineer on request, one current record set of the Drawings which have been accurately marked to indicate all modifications in the completed work that differ from the design information shown on the Drawings. Upon Substantial completion of the work, the Contractor shall give the Engineer one (1) complete set of these marked up record Drawings.

23. ADDITIONAL CONTRACT DOCUMENTS

Copies of Contract Documents or Drawings may be obtained on request from the Engineer and by paying the actual cost of reproducing the Contract Documents or Drawings.

24. OWNERSHIP OF CONTRACT DOCUMENTS

All portions of the Contract Documents, and copies thereof furnished by the Engineer are instruments of service for this project. They are not to be used on other work and are to be returned to the Engineer on request at the completion of the work. Any reuse of these materials without specific written verification or adaptation by the Engineer will be at the risk of the user and without liability or legal expense to the Engineer. Such user shall hold the Engineer harmless from any and all damages, including reasonable attorneys' fees, from any and all claims arising from any such reuse. Any such verification and adaptation shall

entitle the Engineer to further compensation at rates to be agreed upon by the user and the Engineer.

THE ENGINEER

25. AUTHORITY OF THE ENGINEER

The Engineer will be the Owner's representative during the construction period. His/her authority and responsibility will be limited to the provisions set forth in these Contract Documents. The Engineer will have the Authority to reject work that does not conform to the Contract Documents. However, neither the Engineer's authority to act under this provision, nor any decision made by him/her in good faith either to exercise or not to exercise such authority, shall give rise to any duty or responsibility of the Engineer to the Contractor, any Subcontractor, their respective Sureties, any of their agents or employees, or any other person performing any of the work.

26. DUTIES AND RESPONSIBILITIES OF THE ENGINEER

The Engineer will make visits to the site at intervals appropriate to the various stages of construction to observe the progress and quality of the work and to determine, in general, if the work is proceeding in accordance with the intent of the Contract Documents. He/she will not make comprehensive or continuous review or observation to check quality or quantity of the work, and he/she will not be responsible for construction means, methods, techniques, sequences, or procedures, or for safety precautions and programs in connection with the work. Visits and observations made by the Engineer shall not relieve the Contractor of his/her obligation to conduct comprehensive inspections of the work and to furnish materials and perform acceptable work, and to provide adequate safety precautions, in conformance with the intent of the Contract.

The Engineer will make recommendations to the Owner, in writing, on all claims of the Owner or the Contractor arising from interpretation or execution of the Contract Documents. Such recommendations will be of factual and/or technical nature, and will not include the legal interpretation of the Contract Documents. The Owner will make any necessary legal interpretation of the Contract Document. Such recommendation shall be necessary before the Contractor can receive additional money under the terms of the Contract. Changes in work ordered by the Engineer shall be made in compliance with Article CHANGES IN THE WORK.

One or more project representatives may be assigned to observe the work. It is understood that such project representatives shall have the authority to issue notice of nonconformance and make decisions within the limitations of the authority of the Engineer. The Contractor shall furnish all reasonable assistance required by the Engineer or project representatives for proper observation of the work. The above-mentioned project representatives shall not relieve the Contractor of his/her obligations to conduct comprehensive inspections of the work and to furnish materials and perform acceptable work, and to provide adequate safety precautions, in conformance with the intent of the Contract.

27. LIMITATIONS ON ENGINEER'S RESPONSIBILITIES

Engineer will not be responsible for Contractor's means, methods, techniques, sequences,

or procedures of construction, or the safety precautions and programs incident thereto, and Engineer will not be responsible for Contractor's failure to perform or furnish the work in accordance with the Contract Documents.

Engineer will not be responsible for the acts or omissions of Contractor or of any Subcontractor, any supplier, or of any other person or organization performing or furnishing any of the work.

Whenever in the Contract Documents the terms "as ordered", "as directed", "as required", "as allowed", "as approved", or terms of like effect or import are used, or the adjectives "reasonable", "suitable", "acceptable", "proper", or "satisfactory", or adjectives of like effect or import are used to describe a requirement, direction, review or judgment of Engineer as to the work, it is intended that such requirement, direction, review, or judgment will be solely to evaluate the work for compliance with the Contract Documents (unless there is a specific statement indicating otherwise). The use of any such term or adjective shall not be effective to assign to Engineer any duty or authority to supervise or direct the furnishing or performance of the work or any duty or authority to undertake responsibility contrary to the provisions of this Article.

28. REJECTED WORK

Any defective work or nonconforming materials or equipment that may be discovered at any time prior to expiration of the warranty period shall be removed and replaced by work which shall conform to the provisions of the Contract Documents. Any material condemned or rejected shall be removed at once from the project site.

Failure on the part of the Engineer to condemn or reject bad or inferior work or to note nonconforming materials or equipment on Contractor submittals shall not be construed to imply acceptance of such work. The Owner shall reserve and retain all of its rights and remedies at law against the Contractor and its Surety for correction of any and all latent defects discovered after the guarantee period.

29. LINES AND GRADES

Lines and grades shall be established as provided in the supplementary conditions. All stakes, marks, and other reference information shall be carefully preserved by the Contractor, and in case of their careless or unnecessary destruction or removal by him/her or his/her employees, such stakes, marks, and other information shall be replaced at the Contractor's expense.

It will be the Contractor's responsibility to layout the work and to transfer elevations from benchmarks. Where new construction connects to existing facilities, the Contractor shall check and establish the exact location prior to construction of the facilities.

The Contractor shall furnish all surveys, labor, and equipment, including setting all alignment and gradient, grade stakes, batter boards, and everything necessary to lay out his/her work. The Contractor shall be responsible for maintaining and re-establishing at his expense, all control points. After completion of his construction, he shall reset all permanent monuments at their original locations and elevations.

The Engineer may check all layout work, and the Contractor shall furnish all necessary labor, equipment, and materials, and shall cooperate and assist the Engineer in making such checks.

The dimensions for lines and elevations for grades of the fuel system structures, appurtenances, and utilities will be shown on Drawings produced by the Contractor for the issuance of all required permits, together with other pertinent information required for laying out the work. If site conditions vary from those indicated, the Contractor shall notify the Engineer immediately, who will make any minor adjustments as required.

30. SUBMITTALS

After checking and verifying all field measurements and after complying with applicable procedures specified in Division I, GENERAL REQUIREMENTS, Contractor shall submit to Engineer, in accordance with the schedule for submittals for review, shop drawings, electrical diagrams, and catalog cuts for fabricated items and manufactured items (including mechanical and electrical equipment), which shall bear a stamp or specific written indication that Contractor has satisfied Contractor's responsibilities under the Contract Documents with respect to the review of the submittal. All submittals shall be identified as Engineer may require. The data shown shall be complete with respect to quantities, dimensions specified, performance and design criteria, materials, and similar data to enable Engineer to review the information. Contractor shall also submit to Engineer for review, with such promptness as to cause no delay in work, all samples required by the Contract Documents. All samples shall have been checked by and accompanied by a specific written indication that Contractor has satisfied Contractor's responsibilities under the Contract Documents with respect to the review of the submission and shall be identified clearly as to material, supplier, pertinent data such as catalog numbers and the use for which intended.

Before submission of each submittal, Contractor shall have determined and verified all quantities, dimensions, specified performance criteria, installation requirements, materials, catalog numbers, and similar data with respect thereto and reviewed or coordinated each submittal with other submittals and with the requirements of the work and the Contract Documents.

At the time of each submission, Contractor shall give Engineer specific written notice of each variation that the submittal may have from the requirements of the Contract Documents, and, in addition, shall cause a specific notation to be made on each shop drawing submitted to Engineer for review and approval of each variation.

Engineer will review submittals with reasonable promptness, but Engineer's review will be only for conformance with the design concept of the project and for compliance with the information given in the Contract Documents and shall not extend to means, methods, techniques, sequences, or procedures of construction (except where a specific means, method, technique, sequence, or procedure of construction is indicated in or required by the Contract Documents) or to safety precautions or programs incident thereto. The review of a separate item as such will not indicate review of the assembly in which the item functions. Contractor shall make corrections required by Engineer, and shall return the required number of corrected copies of shop drawings and submit as required new samples for review. Contractor shall direct specific attention in writing to revisions other than the

corrections called for by Engineer on previous submittals.

Engineer's review of submittals shall not relieve Contractor from the responsibility for any variation from the requirements of the Contract Documents unless Contractor has in writing called Engineer's attention to each such variation at the time of submission and Engineer has given written approval of each such variation by a specific written notation thereof incorporated therein or accompanying the shop drawing or sample approval; nor will any approval by Engineer relieve Contractor from responsibility for errors or omissions in the shop drawings or from responsibility for having complied with the provisions herein.

Where a shop drawing or sample is required by the specifications, any related work performed prior to Engineer's review and approval of the pertinent submission shall be at the sole expense and responsibility of the Contractor.

31. DETAIL DRAWINGS AND INSTRUCTIONS

The Engineer will furnish, with reasonable promptness, additional instructions by means of Drawings or otherwise, if, in the Engineer's opinion, such are required for the proper execution of the work. All such Drawings and instructions will be consistent with the Contract Documents, true developments thereof, and reasonably inferable there from.

THE CONTRACTOR AND HIS EMPLOYEES

32. CONTRACTOR, AN INDEPENDENT AGENT

The Contractor shall independently perform all work under this Contract and shall not be considered as an agent of the Owner or of the Engineer, nor shall the Contractor's Subcontractors or employees be subagents of the Owner or of the Engineer.

32. (a) ASSIGNMENT OF CONTRACT

Assignment of any part or the whole of this Contract shall be subject to review and approval of the City Commission.

33. SUBCONTRACTING

Unless modified in the Supplementary Conditions, within ten (10) calendar days after the execution of the Contract, the Contractor shall submit to the Engineer the names of all Subcontractors proposed for the work, including the names of any Subcontractors that were submitted with the Bid. The Contractor shall not employ any subcontractors to which the Owner may object to as lacking capability to properly perform work of the type and scope anticipated.

The Contractor is as fully responsible to the Owner for the acts and omissions of his Subcontractors and of persons either directly or indirectly employed by them as he is for the acts and omissions of persons directly employed by him.

Nothing contained in the Contract Documents shall create any contractual relationship between any Subcontractor and the Owner or Engineer.

34. INSURANCE AND LIABILITY

A. GENERAL

The Contractor shall provide (from insurance companies acceptable to the Owner) the insurance coverage designated hereinafter and pay all costs.

Before commencing work under this Contract, Contractor shall furnish the Owner with certificates of insurance specified herein showing the type, amount class of operations covered, effective dates, and date of expiration of policies, and containing substantially the following statement:

"The insurance covered by this certificate shall not be canceled or materially altered, except after 30 days' written notice has been received by the Owner."

In case of the breach of any provision of this Article, the Owner, at his option, may take out and maintain, at the expense of the Contractor, such insurance as the Owner may deem proper and may deduct the cost of such insurance from any monies which may be due or become due the Contractor under this Contract.

B. CONTRACTOR AND SUBCONTRACTOR INSURANCE

The Contractor shall not commence work under this Contract until he has obtained all the insurance required hereunder and such insurance has been reviewed by the Owner, nor shall the Contractor allow any Subcontractor to commence work on his subcontract until insurance specified below has been obtained. Review of the insurance by the Owner shall not relieve or decrease the liability of the Contractor hereunder.

C. COMPENSATION AND EMPLOYER'S LIABILITY INSURANCE

The Contractor shall maintain during the life of this Contract the statutory amount of Workmen's Compensation Insurance, in addition, Employer's Liability Insurance in an amount as specified in the Supplementary Conditions, for each occurrence, for all of his employees to be engaged in work on the project under this Contract. In case any such work is subcontracted, the Contractor shall require the Subcontractor to provide similar Workmen's Compensation and Employer's Liability Insurance for all of the Subcontractor's employees to be engaged in such work.

D. GENERAL LIABILITY INSURANCE (INCLUDING AUTOMOBILE)

See Supplementary Conditions

E. BUILDERS RISK ALL RISK INSURANCE

Unless otherwise modified in the Supplementary Conditions, the Contractor shall secure and maintain during the life of this Contract, Builders Risk All Risk Insurance Coverage in an amount equal to the full value of the facilities under construction. Deductible shall be no greater than \$5,000. Such insurance shall

include coverage for earthquake, landslide, flood, collapse, loss due to the result of faulty workmanship or design, and all other normally covered risks, and shall provide losses to be paid to the Contractor, Owner, and Engineer as their interests may appear.

The Owner and Engineer, their officers, agents, and employees shall be named as additional insureds on the Contractor's and any subcontractors Builders Risk All Risk insurance policies for any claims arising out of work performed under this Contract.

This insurance shall include a waiver of subrogation as to the Engineer, the Owner, the Contractor, and their respective officers, agents, employees, and subcontractors.

F. NO PERSONAL LIABILITY OF PUBLIC OFFICIALS

In carrying out any of the provisions hereof in exercising any authority granted by the Contract, there will be no personal liability upon any public official.

G. SURETY AND INSURER QUALIFICATIONS

All bonds, insurance contracts, and certificates of insurance shall be either executed by or countersigned by a licensed resident agent of the Surety or insurance company, having his place of business in the State of Florida, and in all ways complying with the insurance laws of the State of Florida. Further, the said Surety or insurance company shall be duly licensed and qualified to do business in the State of Florida. If requested, Contractor shall provide proof of Florida Licensure for all insurance companies.

35. INDEMNITY

The following shall be made a provision of any resulting agreement:

To the fullest extent permitted by law, the Contractor expressly agrees to indemnify and hold harmless the City of Key West, their officers, directors, agents, and employees (herein called the "indemnities") from liabilities, damages, losses and costs, including, but not limited to, reasonable attorney's fees and court costs, such legal expenses to include costs incurred in establishing the indemnification and other rights agreed to in this Paragraph, to persons or property, to the extent caused by the negligence, recklessness, or intentional wrongful misconduct of the Contractor its Subcontractors or persons employed or utilized by them in the performance of the Contract. Claims by indemnities for indemnification shall be limited to the amount of Contractor's insurance or \$1 million per occurrence, whichever is greater. The parties acknowledge that the amount of the indemnity required hereunder bears a reasonable commercial relationship to the Contract and it is part of the project specifications or the bid documents, if any.

The indemnification obligations under the Contract shall not be restricted in any way by any limitation on the amount or type of damages, compensation, or benefits payable by or for the Contractor under workers' compensation acts, disability benefits acts, or other employee benefits acts, and shall extend to and include any actions brought by or in the

name of any employee of the Contractor or of any third party to whom Contractor may subcontract a part or all of the Work. This indemnification shall continue beyond the date of completion of the work.

36. EXCLUSION OF CONTRACTOR CLAIMS

In performing its obligations, the Engineer and its Contractors may cause expense for the Contractor or its subcontractors and equipment or material suppliers. However, those parties and their sureties shall maintain no direct action against the Engineer, its officers, employees, agents, and Contractors for any claim arising out of, in connection with, or resulting from the engineering services performed or required to be performed.

37. TAXES AND CHARGES

The Contractor shall withhold and pay any and all sales and use taxes and all withholding taxes, whether State or Federal, and pay all Social Security charges and also all State Unemployment Compensation charges, and pay or cause to be withheld, as the case may be, any and all taxes, charges, or fees or sums whatsoever, which are now or may hereafter be required to be paid or withheld under any laws.

38. REQUIREMENTS OF STATE LAW FOR PUBLIC WORKS PROJECTS

When the Contract Documents concern public works of the state or any county, municipality, or political subdivision created by its laws, the applicable statutes shall apply. All parties to this Contract shall determine the contents of all applicable statutes and comply with their provisions throughout the performance of the Contract.

39. CODES, ORDINANCES, PERMITS, AND LICENSES

The Contractor shall keep himself fully informed of all local codes and ordinances, as well as state and federal laws, which in any manner affect the work herein specified. The Contractor shall at all times comply with said codes and ordinances, laws, and regulations, and protect and indemnify the Owner, the Engineer and their respective employees, and its officers and agents against any claim or liability arising from or based on the violation of any such laws, ordinances, or regulations. All permits, licenses and inspection fees necessary for prosecution and completion of the work shall be secured and paid for by the Contractor, unless otherwise specified.

A. PERMIT FOR WORK WITHIN LOCAL RIGHTS-OF-WAY

The Contractor shall obtain from the City of Key West the necessary permits for work within the rights-of-way. The Contractor shall abide by all regulations and conditions, including maintenance of traffic, FDOT Standard.

B. NOISE ORDINANCE

The Contractor shall comply with the City of Key West Noise Ordinance.

C. LICENSES

BIDDER must represent that he holds all applicable state, county, and City of Key West licenses and permits required to do business as a contractor with respect to the work described in the Contract Documents before he may Bid on the project.

The following licenses and certificates are required as a minimum:

- A. All licenses or certificates required by federal, state or local statutes or regulations.
- B. A valid Business Tax Receipt issued by the City of Key West, if required.
- C. A valid Certificate of Competency issued by the Building Official of the City of Key West which shall remain valid throughout the time period of the Contract, if required.

Further, the successful BIDDER must, within ten (10) calendar days of Notice of Award, furnish documentation showing that, as a minimum, he has complied with the provisions of Chapter 91 of the Code of Ordinances of the City of Key West in order to enter into the Agreement contained in the Contract Documents.

40. SUPERINTENDENCE

The Contractor shall keep at the project site, competent supervisory personnel. The Contractor shall designate, in writing, before starting work, a project superintendent who shall be an employee of the Contractor and shall have complete authority to represent and to act for the Contractor. Engineer shall be notified in writing prior to any change in superintendent assignment. The Contractor shall give efficient supervision to the work, using his best skill and attention. The Contractor shall be solely responsible for all construction means, methods, techniques, and procedures, and for providing adequate safety precautions and coordinating all portions of the work under the Contract. It is specifically understood and agreed that the Engineer, its employees and agents, shall not have control or charge of and shall not be responsible for the construction means, methods, techniques, procedures, or for providing adequate safety precautions in connection with the work under Contract.

40(a). CONTRACTOR'S RESPONSIBILITIES:

- A. The Contractor shall employ such superintendents, foremen, and workmen as are careful and competent. Whenever the Engineer shall determine that any person employed by the Contractor is in his opinion, incompetent, unfaithful, disorderly or insubordinate, such person shall, upon notice, be discharged from the work and shall not again be employed on it except with the written consent of the Engineer. Should the Contractor fail to remove such person or persons, or fail to furnish suitable or sufficient machinery, equipment or force for the proper prosecution of the work the Engineer may withhold all estimates which are, or may become due, or may suspend the work until such orders are complied with.
- B. The Contractor shall provide qualified personnel to assist the Engineer in making field checks, measurements, asbuilt checks, inspection, test runs, and the

necessary quality check work related to the project work. An english speaking superintendent or foreman shall be onsite at all times.

- C. The Contractor shall provide and maintain at his own expense, in a sanitary condition, such accommodations for the use of his employees as is necessary to comply with the requirements and regulations of the State and County Boards of Health. He shall commit no public nuisance.
- D. The Contractor shall conduct the work so as to insure the least obstruction to traffic practicable, and shall provide for the convenience of the general public and of the residents along and adjacent to the work in a manner satisfactory to the Engineer. Materials and equipment stored on the work site shall be placed so as to cause as little obstruction to the public as possible and shall be lighted and barricaded as hereinafter provided. Keep driveways and entrances serving the premises clear and available to the Owner and the Owner's employees at all times. Do not use these areas for parking or storage of materials and equipment on site.
- E. Unless otherwise expressly stipulated herein, the use of explosives is not contemplated in the prosecution of the Contract, and in no case will their use be permitted within a municipality without the written permission of the City Engineer and a permit issued by the Chief of the Fire Department. Where such permission for the use of explosives is obtained, the Contractor shall use the utmost care so as not to endanger life or property, and whenever directed the size and number of charges shall be reduced. All explosives shall be stored in a secure manner, and all such storage places shall be marked clearly, "DANGEROUS EXPLOSIVES", and shall be in care of competent watchmen

41. RECEPTION OF ENGINEER'S COMMUNICATIONS

The superintendent shall receive for the Contractor all communications from the Engineer. Communications of major importance will be confirmed in writing upon request from the Contractor.

The Engineer may schedule project meetings for the purposes of discussing and resolving matters concerning the various elements of the work. The Engineer shall determine the time and place for these meetings, and the names of persons required being present. The Contractor shall comply with these attendance requirements and shall also require his/her Subcontractors to comply.

42. SAFETY

The Contractor shall be solely and completely responsible for conditions of the jobsite, including safety of all persons (including employees) and property during performance of the work. This requirement shall apply continuously and not be limited to normal working hours. Safety provisions shall conform to U.S. Department of Labor (OSHA), and all other applicable federal, state, county, and local laws, ordinances, codes, and regulations. Where any of these are in conflict, the more stringent requirement shall be followed. The Contractor's failure to thoroughly familiarize himself/herself with the aforementioned safety provisions shall not relieve him from compliance with the obligations and penalties

set forth therein.

The Contractor shall develop and maintain for the duration of this Contract, a safety program that will effectively incorporate and implement all required safety provisions. The Contractor shall appoint an employee who is qualified and authorized to supervise and enforce compliance with the safety program.

The duty of the Engineer to conduct construction review of the work does not include review or approval of the adequacy of the Contractor's safety program, safety supervisor, or any safety measures taken in, on, or near the construction site.

The Contractor, as a part of his safety program, shall maintain at hi/hers office or other well-known place at the jobsite, safety equipment applicable to the work as prescribed by the aforementioned authorities, all articles necessary for giving first-aid to the injured, and shall establish the procedure for the immediate removal to a hospital or a doctor's care of persons (including employees) who may be injured on the jobsite.

If death or serious injuries or serious damages are caused, the accident shall be reported immediately by telephone or messenger to both the Engineer and the Owner. In addition, the Contractor must promptly report in writing to the Engineer all accidents whatsoever arising out of, or in connection with, the performance of the work whether on, or adjacent to, the site, giving full details and statements of witnesses.

If a claim is made by anyone against the Contractor or any Subcontractor on account of any accident, the Contractor shall promptly report the facts in writing to the Engineer, giving full details of the claim.

A. OWNER'S RIGHT TO STOP WORK

If the Contractor or Subcontractor fails to provide adequate safety provisions as required by the Contract Documents the Owner has the right to stop all construction work at the location with inadequate safety provisions until adequate provisions are in place. The Owner shall not be liable for any delays caused by the Contractor's failure to provide and maintain required safety provisions.

B. CLEANUP PROCEDURES FOR HURRICANE WARNINGS AND HURRICANE WATCH

In the event the National Oceanographic and Atmospheric Administration (NOAA) issues a Tropical Storm Watch or a Hurricane Watch for the Keys the Engineer will Contact the Contractor informing him that the Watch has been established. Within four (4) hours of the notice the Contractor shall provide the Engineer with a written plan and schedule describing how and when the Contractor will remove all unnecessary items from the work area and tie down all necessary supplies and barricades in the event a Tropical Storm Warning or a Hurricane Warning is issued. The Contractor shall remove all unnecessary items from work areas and shall tie down all movable objects (under 200 lbs.) The Engineer will determine "necessary" items. The Owner shall not be liable for any financial hardship or delays caused as a result of demobilization or remobilization of work due to the above.

C. OCCUPATIONAL SAFETY AND HEALTH

The Contractor shall observe and comply with all applicable local, state, and federal occupational safety and health regulations during the prosecution of work under this Contract. In addition, full compliance by the Contractor with the U.S. Department of Labor's Occupational Safety and Health Standards, as established in Public Law 91-596, will be required under the terms of this Contract.

43. PROTECTION OF WORK AND PROPERTY

The Contractor shall at all times safely guard and protect from damage the Owner's property, adjacent property, and his/her own work from injury or loss in connection with this Contract. All facilities required for protection by federal, state, or municipal laws and regulations and local conditions must be provided and maintained.

The Contractor shall protect his/her work and materials from damage due to the nature of the work, the elements, carelessness of other contractors, or from any cause whatever until the completion and acceptance of the work. All loss or damages arising out of the nature of the work to be done under these Contract Documents, or from any unforeseen obstruction or defects which may be encountered in the prosecution of the work, or from the action of the elements, shall be sustained by the Contractor.

43(a). HISTORIC PRESERVATION

The Contractor shall comply with Florida Historical Resources Act (Florida Statutes, Chapter 267) and the regulations of the local historic preservation board as applicable and protect against the potential loss or destruction of significant historical or archaeological data, sites, and properties in connection with the project.

44. RESPONSIBILITY OF CONTRACTOR TO ACT IN AN EMERGENCY

In case of an emergency that threatens loss or injury of property, and/or safety of life, the Contractor shall act, without previous instructions from the Owner or Engineer, as the situation may warrant. The Contractor shall notify the Engineer thereof immediately thereafter. Any claim for compensation by the Contractor, together with substantiating documents in regard to expense, shall be submitted to the Owner through the Engineer and the amount of compensation shall be determined by agreement.

45. MATERIALS AND APPLIANCES

Unless otherwise stipulated, the Contractor shall provide and pay for all materials, labor, water, tools, equipment, heat, light, fuel, power, transportation, construction equipment and machinery, appliances, telephone, sanitary facilities, temporary facilities and other facilities and incidentals necessary for the execution and completion of the work.

Unless otherwise specified, all materials shall be new, and both workmanship and materials shall be of good quality. The Contractor shall, if required, furnish satisfactory evidence as to the kind and quality of materials.

In selecting and/or approving equipment for installation in the project, the Owner and Engineer assume no responsibility for injury or claims resulting from failure of the equipment to comply with applicable federal, state, and local safety codes or requirements, or the safety requirements of a recognized agency, or failure due to faulty design concepts, or defective workmanship and materials.

46. CONTRACTORS' AND MANUFACTURERS' COMPLIANCE WITH STATE SAFETY, OSHA, AND OTHER CODE REQUIREMENTS

The completed work shall include all necessary permanent safety devices, such as machinery guards and similar ordinary safety items required by the state and federal (OSHA) industrial authorities and applicable local and national codes. Further, any features of the work subject to such safety regulations shall be fabricated, furnished, and installed (including Owner-furnished equipment) in compliance with these requirements. Contractors and manufacturers of equipment shall be held responsible for compliance with the requirements included herein. Contractors shall notify all equipment suppliers and Subcontractors of the provisions of this Article.

47. SUBSTITUTION OF MATERIALS

Except for Owner-selected equipment items, and items where no substitution is clearly specified, whenever any material, article, device, product, fixture, form, type of construction, or process is indicated or specified by patent or proprietary name, by name of manufacturer, or by catalog number, such specifications shall be deemed to be used for the purpose of establishing a standard of quality and facilitating the description of the material or process desired. This procedure is not to be construed as eliminating from competition other products of equal or better quality by other manufacturers where fully suitable in design, and shall be deemed to be followed by the words "or equal". The Contractor may, in such cases, submit complete data to the Engineer for consideration of another material, type, or process, which shall be substantially equal in every respect to that so indicated or specified. Substitute materials shall not be used unless approved in writing. The Engineer will be the sole judge of the substituted article or material.

48. TESTS, SAMPLES, AND OBSERVATIONS

The Contractor shall furnish, without extra charge, the necessary test pieces and samples, including facilities and labor for obtaining the same, as requested by the Engineer. When required, the Contractor shall furnish certificates of tests of materials and equipment made at the point of manufacture by a recognized testing laboratory.

The Owner, Engineer, and authorized government agents, and their representatives shall at all times be provided safe access to the work wherever it is in preparation or progress, and the Contractor shall provide facilities for such access and for observations, including maintenance of temporary and permanent access.

If the Specifications, laws, ordinances, or any public authority require any work, to be specially tested or approved, the Contractor shall give timely notice of its readiness for observations. If any work should be covered up without approval or consent of the Engineer, it shall, if required by the Engineer, be uncovered for examination at the Contractor's expense.

The Engineer may order re-examination of questioned work, and, if so ordered, the Contractor shall uncover the work. If such work is found to be in accordance with the Contract Documents, the Owner will pay the cost of uncovering, exposure, observation, inspection, testing and reconstruction. If such work is found to be not in accordance with the Contract Documents, the Contractor shall correct the defective work, and the cost of reexamination and correction of the defective work shall be paid by the Contractor.

49. ROYALTIES AND PATENTS

The Contractor shall pay all royalty and licenses fees, unless otherwise specified. The Contractor shall defend all suits or claims for infringement of any patent rights and shall save the Owner and the Engineer harmless from any and all loss, including reasonable attorneys' fees, on account thereof.

50. CONTRACTOR'S RIGHT TO TERMINATE CONTRACT

If the work should be stopped under an order of any court or other public authority for a period of more than three (3) months, through no act or fault of the Contractor, its Subcontractors, or respective employees or if the Engineer should fail to make recommendation for payment to the Owner or return payment request to Contractor for revision within thirty (30) calendar days after it is due, or if the Owner should fail to pay the Contractor within thirty (30) calendar days after time specified in Article PARTIAL PAYMENTS, any sum recommended by the Engineer, then the Contractor may, upon 15 days' written notice to the Owner and the Engineer, stop work or terminate this Contract and recover from the Owner payment for all acceptable work performed and reasonable termination expenses, unless said default has been remedied.

51. CORRECTION OF DEFECTIVE WORK DURING WARRANTY PERIOD

The Contractor hereby agrees to make, at his own expense, all repairs or replacements necessitated by defects in materials or workmanship, provided under terms of this Contract, and pay for any damage to other works resulting from such defects, which become evident within two (2) year after the date of final acceptance of the work or within two (2) year after the date of substantial completion established by the Engineer for specified items of equipment, or within such longer period as may be prescribed by law or by the terms of any applicable special guarantee required by the Contract Documents. Un-remedied defects identified for correction during the warranty period but remaining after its expiration shall be considered as part of the obligations of the warranty. Defects in material, workmanship, or equipment, which are remedied as a result of obligations of the warranty, shall subject the remedied portion of the work to an extended warranty period of two (2) year after the defect has been remedied.

The Contractor further assumes responsibility for a similar guarantee for all work and materials provided by Subcontractors or manufacturers of packaged equipment components. The effective date for the start of the guarantee or warranty period for equipment qualifying as substantially complete is defined in Article SUBSTANTIAL COMPLETION, AND Article SUBSTANTIAL COMPLETION DATE, in these General Conditions.

The Contractor also agrees to hold the Owner and the Engineer harmless from liability of any kind arising from damage due to said defects. The Contractor shall make all repairs and replacements promptly upon receipt of written order for same from the Owner. If the Contractor fails to make the repairs and replacements promptly, or in an emergency where delay would cause serious risk, or loss, or damage, the Owner may have the defective work corrected or the rejected work removed and replaced, and the Contractor and his Surety shall be liable for the cost thereof.

PROGRESS OF THE WORK

52. BEGINNING OF THE WORK

Following execution of the Contract, the Contractor shall meet with the Owner and Engineer relative to his arrangements for prosecuting the work.

53. SCHEDULES AND PROGRESS REPORTS

Prior to starting the construction, the Contractor shall prepare and submit to the Engineer, a progress schedule showing the dates on which each part or division of the work is expected to be started and finished, and a preliminary schedule for submittals. The progress schedule for submittals shall be brought up to date and submitted to the Engineer at the end of each month or at such other times the Engineer may request.

The Contractor shall forward to the Engineer, at the end of each month, an itemized report of the delivery status of major and critical items of purchased equipment and material, including shop drawings and the status of shop and field fabricated work. These progress reports shall indicate the date of the purchase order, the current percentage of completion, estimated delivery, and cause of delay, if any.

If the completion of any part of the work or the delivery of materials is behind the submitted progress schedule, the Contractor shall submit in writing a plan acceptable to the Owner and Engineer for bringing the work up to schedule.

The Owner shall have the right to withhold progress payments for the work if the Contractor fails to update and submit the progress schedule and reports as specified.

Unless specifically authorized by the Engineer, work shall not be performed during the Goombay Festival, Fantasy Fest, Thanksgiving, or Christmas.

54. PROSECUTION OF THE WORK

It is expressly understood and agreed that the time of beginning, rate of progress, and time of completion of the work are the essence of this Contract. The work shall be prosecuted at such time, and in or on such part or parts of the project as may be required, to complete the project as contemplated in the Contract Documents and the progress schedule.

If the Contractor desires to carry on work at night or outside the regular hours, he shall give timely notice to the Engineer to allow satisfactory arrangements to be made for observing the work in progress.

55. OWNER'S RIGHT TO RETAIN IMPERFECT WORK

If any part or portion of the work completed under this Contract shall prove defective and not in accordance with the Drawings and Specifications, and if the imperfection in the same shall not be of sufficient magnitude or importance as to make the work dangerous or unsuitable, or if the removal of such work will create conditions which are dangerous or undesirable, the Owner shall have the right and authority to retain such work but will make such deductions in the final payment therefore as may be just and reasonable.

55(a). OWNER'S RIGHT TO STOP WORK

If the Contractor or any subcontractor should fail to provide adequate safety provisions required by the Contract Documents, including but not limited to maintenance of traffic, trench safety devices and procedures, safety fencing, barricading, signage or unsafe work practices, the Owner has the right to issue a Stop Work Notice and stop all construction work at the location with the inadequate safety provisions until such time that adequate safety provisions are in place. The Owner shall not be liable for delays caused by the Contractor's failure to provide and maintain required safety provisions. No extension of time will be granted to the Contractor for delays occurring due to a Stop Work Notice.

56. OWNER'S RIGHT TO DO WORK

Should the Contractor neglect to prosecute the work in conformance with the Contract Documents or neglect or refuse at his own cost to remove and replace work rejected by the Engineer, then the Owner may notify the Surety of the condition, and after ten (10) calendar days' written notice to the Contractor and the Surety, or without notice if an emergency or danger to the work or public exists, and without prejudice to any other right which the Owner may have under Contract, or otherwise, take over that portion of the work which has been improperly or non timely executed, and make good the deficiencies and deduct the cost thereof from the payments then or thereafter due the Contractor.

57. OWNER'S RIGHT TO TRANSFER EMPLOYMENT

If the Contractor should abandon the work or if he should persistently or repeatedly refuse or should fail to make prompt payment to Subcontractors for material or labor, or to persistently disregard laws, ordinances, or to prosecute the work in conformance with the Contract Documents, or otherwise be guilty of a substantial violation of any provision of the Contract or any laws or ordinance, then the Owner may, without prejudice to any other right or remedy, and after giving the Contractor and Surety 10 days' written notice, transfer the employment for said work from the Contractor to the Surety. Upon receipt of such notice, such Surety shall enter upon the premises and take possession of all materials, tools, and appliances thereon for the purpose of completing the work included under this Contract and employ by Contract or otherwise, any qualified person or persons to finish the work and provide the materials therefore, in accordance with the Contract Documents, without termination of the continuing full force and effect of this Contract. In case of such transfer of employment to such Surety, the Surety shall be paid in its own name on estimates according to the terms hereof without any right of the Contractor to make any claim for the same or any part thereof.

If, after the furnishing of said written notice to the Surety, the Contractor and the Surety still fail to make reasonable progress on the performance of the work, the Owner may

terminate the employment of the Contractor and take possession of the premises and of all materials, tools, and appliances thereon and finish the work by whatever method he may deem expedient and charge the cost thereof to the Contractor and the Surety. In such case, the Contractor shall not be entitled to receive any further payment until the work is finished. If the expense of completing the Contract, including compensation for additional managerial and administrative services, shall exceed such unpaid balance, the Contractor and the Surety shall pay the difference to the Owner.

58. DELAYS AND EXTENSION OF TIME

If the Contractor is delayed in the progress of the work by any act or neglect of the Owner or the Engineer, or by any separate Contractor employed by the Owner, or by strikes, lockouts, fire, adverse weather conditions not reasonably anticipated, or acts of Nature, and if the Contractor, within forty-eight (48) hours of the start of the occurrence, gives written notice to the Owner of the cause of the potential delay and estimate of the possible time extension involved, and within ten (10) calendar days after the cause of the delay has been remedied, the Contractor gives written notice to the Owner of any actual time extension requested as a result of the aforementioned occurrence, then the Contract time may be extended by change order for such reasonable time as the Engineer determines. It is agreed that no claim shall be made or allowed for any damages, loss, or expense which may arise out of any delay caused by the above referenced acts or occurrences other than claims for the appropriate extension of time.

No extension of time will be granted to the Contractor for delays occurring to parts of the work that have no measurable impact on the completion of the total work under this Contract. No extension of time will be considered for weather conditions reasonably anticipated for the area in which the work is being performed. Reasonably anticipated weather conditions will be based on official records of monthly precipitation and other historical data. Adverse weather conditions, if determined to be of a severity that would impact progress of the work, may be considered as cause for an extension of Contract completion time.

Delays in delivery of equipment or material purchased by the Contractor or his Subcontractors, including Owner-selected equipment shall not be considered as a just cause for delay, unless the Owner determines that for good cause the delay is beyond the control of the Contractor. The Contractor shall be fully responsible for the timely ordering, scheduling, expediting, delivery, and installation of all equipment and materials.

Within a reasonable period after the Contractor submits to the Owner a written request for an extension of time, the Engineer will present his written opinion to the Owner as to whether an extension of time is justified, and, if so, his recommendation as to the number of days for time extension. The Owner will make the final decision on all requests for extension of time.

59. DIFFERING SITE CONDITIONS

The Contractor shall promptly, and before the conditions are disturbed, give a written notice to the Owner and Engineer of:

A. Subsurface or latent physical conditions at the site which differ materially from

those indicated in this contract,

- B. Unknown physical conditions at the site, of an unusual nature, which differ materially from those ordinarily encountered and generally recognized as inherent in work of the character provided for in the Contract.

The Engineer will investigate the site conditions promptly after receiving the notice. If the conditions do materially so differ and cause an increase or decrease in the Contractor's cost of, or the time required for, performing any part of the work under this Contract, whether or not changed as a result of the conditions, and equitable adjustment shall be made under this Article and the Contract modified in writing accordingly.

No request by the Contractor for an equitable adjustment to the Contract under this Article will be allowed, unless the Contractor has given the written notice required; provided that the time prescribed above for giving written notice may be extended by the Owner.

No request by the Contractor for an equitable adjustment to the Contract for differing site conditions will be allowed if made after final payment under this Contract.

60. LIQUIDATED DAMAGES

Should the Contractor fail to complete the work, or any part thereof in the time agreed upon in each Work Order or within such extra time as may have been allowed for delays by extensions granted as provided in the Contract, the Contractor shall reimburse the Owner for the additional expense and damage for each calendar day, Sundays, and legal holidays included, that project outlined in each Work Order remains uncompleted after the Work Order completion date. Liquidated damages shall be assessed individually against each Work Order. It is agreed that the amount of such additional expense and damage incurred by reason of failure to complete the work is the per diem rate, as stipulated in the Bid. The said amount is hereby agreed upon as a reasonable estimate of the costs that may be accrued by the Owner after the expiration of the time of completion. It is expressly understood and agreed that this amount is not to be considered in the nature of a penalty, but as liquidated damages that have accrued against the Contractor. The Owner shall have the right to deduct such damages from any amount due, or that may become due the Contractor, or the amount of such damages shall be due and collectible from the Contractor or Surety.

61. OTHER CONTRACTS

The Owner reserves the right to let other Contracts in connection with the work. The Contractor shall afford other Contractors reasonable opportunity for the introduction and storage of their materials and the execution of their work and shall properly connect and coordinate his work with theirs.

If any part of the work under this Contract depends for proper execution or results upon the work of any other Contractor, utility service company or Owner, the Contractor shall inspect and promptly report to the Engineer in writing any patent or apparent defects to deficiencies in such work that render it unsuitable for such proper execution and results. The Contractor's failure to so report shall constitute and acceptance of the work by others as being fit and proper for integration with work under this Contract, except for latent or non apparent defects and deficiencies in the work.

62. USE OF PREMISES

The Contractor shall confine his equipment, the storage of materials and the operation of his workers to limits shown on the Drawings or indicated by law, ordinances, permits, or directions of the Engineer, and shall not unreasonably encumber the premises with his materials. The Contractor shall provide, at his own expense, the necessary rights-of-way, and access to the work, which may be required outside the limits of the Owner's property and shall furnish the Engineer copies of permits and agreements for use of the property outside that provided by the Owner.

The Contractor shall not load nor permit any part of the structure to be loaded in any manner that will endanger the structure, nor shall Contractor subject any part of the work or adjacent property to stresses or pressures that will endanger it.

63. SUBSTANTIAL COMPLETION DATE

The Engineer may issue a written notice of substantial completion for the purpose of establishing the starting date for specific equipment guarantees, and to establish the date that the Owner will assume the responsibility for the cost of operating such equipment. Said notice shall not be considered as final acceptance of any portion of the work or relieve the Contractor from completing the remaining work within the specified time and in full compliance with the Contract Documents. See SUBSTANTIAL COMPLETION under DEFINITIONS of these General Conditions.

64. PERFORMANCE TESTING

Operating equipment and systems shall be performance tested in the presence of the Engineer to demonstrate compliance with the specified requirements. Performance testing shall be conducted under the specified design operating conditions or under such simulated operating conditions as recommended or approved by the Engineer. Such testing will be scheduled with the Engineer at least one week in advance of the planned date for testing.

65. OWNER'S USE OF PORTIONS OF THE WORK

Following issuance of the written notice of Substantial Completion, the Owner may initiate operation of the facility. Such use shall not be considered as final acceptance of any portion of the work, nor shall such use be considered as cause for an extension of the Contract completion time, unless authorized by a Change Order issued by the Owner.

66. CUTTING AND PATCHING

The Contractor shall do all cutting, fitting, or patching of his work that may be required to make its several parts come together properly and fit it to receive or be received by work of other Contractors shown upon or reasonably implied by the Drawings.

67. CLEANING UP

The Contractor shall, at all times, keep property on which work is in progress and the adjacent property free from accumulations of waste material or rubbish caused by employees or by the work. Upon completion of the construction, the Contractor shall

remove all temporary structures, rubbish, and waste materials resulting from his operations.

PAYMENT

68. PAYMENT FOR CHANGE ORDERS

The Owner's request for quotations on alterations to the work shall not be considered authorization to proceed with the work prior to the issuance of a formal Change Order, nor shall such request justify any delay in existing work. Quotations for alterations to the work shall include substantiating documentation with an itemized breakdown of Contractor and Subcontractor costs, including labor, material, rentals, approved services, overhead, and profit. Owner may require detailed cost data in order to substantiate the reasonableness of the proposed costs.

Any compensation paid in conjunction with the terms of a Change Order shall comprise total compensation due the Contractor for the work or alteration defined in the Change Order. By signing the Change Order, the Contractor acknowledges that the stipulated compensation includes payment for the work or alteration plus all payment for the interruption of schedules, extended overhead, delay, or any other impact claim or ripple effect, and by such signing specifically waives any reservation or claim for additional compensation in respect to the subject Change Order.

At the Owner's option, payment or credit for any alterations covered by a Change Order shall be determined by one or a combination of the methods set forth in A, B, or C below, as applicable:

A. UNIT PRICES

Those unit prices stipulated in the Bid shall be utilized where they are applicable. In the event the Change Order results in a change in the original quantity that is materially and significantly different from the original Bid quantity, a new unit price shall be negotiated upon demand of either party. Unit prices for new items included in the Change Order shall be negotiated and mutually agreed upon.

B. LUMP SUM

A total lump sum for the work negotiated and mutually acceptable to the Contractor and the Owner.

Lump sum quotations for modifications to the work shall include substantiating documentation with an itemized breakdown of Contractor and Subcontractor costs, including labor, material, rentals, approved services, overhead, and profit, all calculated as specified under "C" below.

C. COST REIMBURSEMENT WORK

The term "cost reimbursement" shall be understood to mean that payment for the work will be made on a time and expense basis, that is, on an accounting of the Contractor's forces, materials, equipment, and other items of cost as required and used to do the work.

If the method of payment cannot be agreed upon prior to the beginning of the work,

and the Owner directs by written Change Order that the work be done on a cost reimbursement basis, then the Contractor shall furnish labor, and furnish and install equipment and materials necessary to complete the work in a satisfactory manner and within a reasonable period of time. For the work performed, payment will be made for the documented actual cost of the following:

1. Labor including foremen for those hours they are assigned and participating in the cost reimbursement work (actual payroll cost, including wages, fringe benefits as established by negotiated labor agreements, labor insurance, and labor taxes as established by law). No other fixed labor burdens will be considered, unless approved in writing by the Owner.
2. Material delivered and used on the designated work, including sales tax, if paid by the Contractor or his Subcontractor.
3. Rental, or equivalent rental cost of equipment, including necessary transportation for items having a value in excess of one hundred (100) dollars.

Rental or equivalent rental cost will be allowed for only those days or hours during which the equipment is in actual use. Rental and transportation allowances shall not exceed the current rental rates prevailing in the locality. The rentals allowed for equipment will, in all cases, be understood to cover all fuel, supplies, repairs, and renewals, and no further allowances will be made for those items, unless specific agreement to that effect is made.

4. Additional bond, as required and approved by the owner.
5. Additional insurance (other than labor insurance) as required and approved by the Owner.

In addition to items 1 through 5 above, an added fixed fee for general overhead and profit shall be negotiated and allowed for the Contractor (or approved Subcontractor) actually executing the Cost Reimbursement work.

An additional fixed fee shall be negotiated and allowed the Contractor for the administrative handling of portions of the work that are executed by an approved Subcontractor. No additional fixed fee will be allowed for the administrative handling of work executed by a Subcontractor of a Subcontractor, unless by written permission from the Owner.

The added fixed fees shall be considered to be full compensation, covering the cost of general supervision, overhead, profit, and any other general expense. The Contractor's records shall make clear distinction between the direct costs of work paid for on a cost reimbursement basis and the costs of other work. The Contractor shall furnish the Engineer report sheets in duplicate of each day's cost reimbursement work no later than the working day following the performance of said work. The daily report sheets shall itemize the materials used, and shall cover the direct cost of labor and the charges for equipment rental, whether furnished by the Contractor, Subcontractor or other forces. The daily report sheets shall provide names or identifications and classifications of workers, the hourly rate of pay and hours worked, and also the size, type, and identification number of equipment and

hours operated.

Valid copies of vendors' invoices shall substantiate material charges. Such invoices shall be submitted with the daily report sheets, or, if not available, they shall be submitted with subsequent daily report sheets. Said daily report sheets shall be signed by the Contractor or his authorized agent.

The Owner reserves the right to furnish such materials and equipment as he deems expedient and the Contractor shall have no claim for profit or added fees on the cost of such materials and equipment. To receive partial payments and final payment for cost reimbursement work, the Contractor shall submit to the Engineer, detailed and complete documented verification of the Contractor's and any of his Subcontractors' actual costs involved in the cost reimbursement work. Such costs shall be submitted within 30 days after said work has been performed.

69. PARTIAL PAYMENTS

A. GENERAL

Nothing in this Article shall be construed to affect the right, hereby reserved, to reject the whole or any part of the aforesaid work, should such work be later found not to comply with the provisions of the Contract Documents. All estimated quantities of work for which partial payments have been made are subject to review and correction on the final estimate. Payment by the Owner and acceptance by the Contractor of partial payments based on periodic estimates of quantities of work performed shall not, in any way, constitute acceptance of the estimated quantities used as a basis for computing the amounts of the partial payments.

B. ESTIMATE

No more than once each month, the Contractor shall submit to the Engineer a detailed estimate of the amount earned during the preceding month for the separate portions of the work, and request payment. As used in this Article, the words "amount earned" means the value, on the date of the estimate for partial payment, of the work completed in accordance with the Contract Documents, and the value of approved materials delivered to the project site suitably stored and protected prior to incorporation into the work.

The Owner will make payment to the Contractor within forty five (45) calendar days upon receipt of the written recommendation of payment from the Engineer.

The Engineer will, within seven (7) calendar days after receipt of each request for payment, both indicate in writing a recommendation of payment and present the request to Owner, or return the request to Contractor indicating in writing Engineer's reasons for refusing to recommend payment. In the latter case, Contractor may, within seven (7) calendar days, make the necessary corrections and resubmit the request.

Engineer may refuse to recommend the whole or any part of any payment if, in his opinion, it would be incorrect to make such representations to Owner. Engineer

may also refuse to recommend any such payment, or, because of subsequently discovered evidence or the results of subsequent inspections or tests, nullify any such payment previously recommended to such an extent as may be necessary in Engineer's opinion to protect the Owner from loss because:

1. The work is defective, or completed work has been damaged requiring correction or replacement.
2. Written claims have been made against Owner or Liens have been filed in connection with the work.
3. The Contract Price has been reduced because of Change Orders.
4. Owner has been required to correct defective work or complete the work in accordance with Article OWNER'S RIGHT TO DO WORK;
5. Of Contractor's unsatisfactory prosecution of the work in accordance with the Contract Documents; or
6. Contractor's failure to make payment to Subcontractors or for labor, materials, or equipment.

C. DEDUCTION FROM ESTIMATE

Unless modified in the Supplementary Conditions, deductions from the estimate will be as described below:

1. The Owner will deduct from the estimate, and retain as part security, ten (10) percent of the amount earned for work satisfactorily completed. A deduction and retainage of ten (10) percent will be made on the estimated amount earned for approved items of material delivered to and properly stored at the jobsite but not incorporated into the work. When the work is fifty (50) percent complete, the Owner may reduce the retainage to five (5) percent of the dollar value of all work satisfactorily completed to date provided the Contractor is making satisfactory progress and there is no specific cause for a greater retainage. The Owner may reinstate the retainage up to ten (10) percent if the Owner determines, at his discretion, that the Contractor is not making satisfactory progress or where there is other specific cause for such withholding.

D. QUALIFICATION FOR PARTIAL PAYMENT FOR MATERIALS DELIVERED

Unless modified in the Supplementary Conditions, qualification for partial payment for materials delivered but not yet incorporated into the work shall be as described below:

1. Materials, as used herein, shall be considered to be those items that are fabricated and manufactured material and equipment. No consideration shall be given to individual purchases of less than two hundred (200) dollars

for any one item.

2. To receive partial payment for materials delivered to the site, but not incorporated in the work, it shall be necessary for the Contractor to include a list of such materials on the Partial Payment Request. At his sole discretion, the Engineer may approve items for which partial payment is to be made. Partial payment shall be based on the Contractor's actual cost for the materials as evidenced by invoices from the supplier. Proper storage and protection shall be provided by the Contractor, and as approved by the Engineer. Final payment shall be made only for materials actually incorporated in the work and, upon acceptance of the work, all materials remaining for which advance payments had been made shall revert to the Contractor, unless otherwise agreed, and partial payments made for these items shall be deducted from the final payment for the work.
3. Contractor warrants and guarantees that title to all work, materials, and equipment covered by any Application for Payment, whether incorporated in the project or not, will pass to Owner at the time of payment free and clear of all liens, claims, security interests, and encumbrances.
4. If requested by the Engineer, the Contractor shall provide, with subsequent pay requests, invoices received by the supplier showing payment in full has been made.

E. PAYMENT

After deducting the retainage and the amount of all previous partial payments made to the Contractor from the amount earned, the amount due will be made payable to the Contractor. Recommendations for payment received by the Owner less than forty five (45) calendar days prior to the scheduled day for payment will not be processed or paid until the following month.

70. CLAIMS FOR EXTRA WORK

In any case where the Contractor deems additional time or compensation will become due him under this Contract for circumstances other than those defined in Article DELAYS AND EXTENSION OF TIME, the Contractor shall notify the Engineer, in writing, of his intention to make claim for such time or compensation before he begins the work on which he bases the claim, in order that such matters may be settled, if possible, or other appropriate action taken. The notice of claim shall be in duplicate, in writing, and shall state the circumstances and the reasons for the claim, but need not state the amount. If such notification is not given, or if the Engineer is not afforded proper facilities by the Contractor for keeping strict account of actual costs, then the Contractor hereby agrees to waive the claim for such additional time or compensation. Such notice by the Contractor, and fact that the Engineer has kept account of the cost as aforesaid, shall not in any way be construed as proving the validity of the claim.

No extension of time will be granted to the Contractor for delays resulting from extra work that have no measurable impact on the completion of the total Work under this Contract. Claims for additional time or compensation shall be made in itemized detail and submitted,

in writing, to the Owner and Engineer within ten (10) calendar days following completion of that portion of the work for which the Contractor bases his claim. Failure to make the claim for additional compensation in the manner and within the time specified above shall constitute waiver of that claim. In case the claim is found to be just, it shall be allowed and paid for as provided in Article PAYMENT FOR CHANGE ORDERS.

71. RELEASE OF LIENS OR CLAIMS

The Contractor shall indemnify and hold harmless the Owner from all claims for labor and materials furnished under this Contract. Prior to the final payment, the Contractor shall furnish to the Owner, as part of his final payment request, a certification that all of the Contractor's obligations on the project have been satisfied and that all monetary claims and indebtedness have been paid. The Contractor shall furnish complete and legal effective releases or waivers, satisfactory to the Owner, of all liens arising out of or filed in connection with the work.

72. FINAL PAYMENT

Upon completion of the work, the Contractor shall notify the Engineer, in writing, that he has completed it and shall request final payment for that Work Performed. The Contractor shall be responsible for keeping an accurate and detailed record of his actual construction. Upon completion of construction and before final acceptance and payment, the Contractor shall furnish the Engineer record drawings (if applicable) of his construction. Upon receipt of a request for final payment and the record drawings, the Engineer will inspect and, if acceptable, submit to the Owner his recommendation as to acceptance of the completed work and as to the final estimate of the amount due the Contractor. Upon approval of this final estimate by the Owner and compliance by the Contractor with provisions in Article 71. RELEASE OF LIENS OR CLAIMS, and other provisions as may be applicable, the Owner shall pay to the Contractor all monies due him under the provisions of these Contract Documents.

73. NO WAIVER OF RIGHTS

Neither the inspection by the Owner, through the Engineer or any of his employees, nor any order by the Owner for payment of money, nor any payment for, or acceptance of, the whole or any part of the work by the Owner or Engineer, nor any extension of time, nor any possession taken by the owner or its employees, shall operate as a waiver of any provision of this Contract, or any power herein reserved to the Owner, or any right to damages herein provided, nor shall any waiver of any breach in this Contract be held to be a waiver of any other or subsequent breach. Acceptance or final payment shall not be final and conclusive with regards to latent defects, fraud, or such gross mistakes as may amount to fraud, or as regards the Owner's rights under the warranty.

74. ACCEPTANCE OF FINAL PAYMENT CONSTITUTES RELEASE

The acceptance by the Contractor of the final payment shall release the Owner and the Engineer, as representatives of the Owner, from all claims and all liability to the Contractor for all things done or furnished in connection with the work, and every act of the Owner and others relating to or arising out of the work except claims previously made in writing and still unsettled. No payment, however, final or otherwise, shall operate to release the

Contractor or his Sureties from obligations under this Contract and the Performance Bond, Payment Bond, and other bonds and warranties, as herein provided.

SUPPLEMENTARY CONDITIONS

REVISIONS AND ADDITIONS TO THE GENERAL CONDITIONS

The General Conditions are hereby revised as follows:

ARTICLE 9 "ENGINEER"

Add the following:

Wherever in these Documents the word "Engineer" appears, it shall be understood to mean the Owner's representative overseeing the project for the City.

ARTICLE 34 INSURANCE AND LIABILITY

The Contractor shall maintain limits no less than those stated below:

CONTRACTOR is to secure, pay for, and file with the City of Key West, prior to commencing any work under the Contract, all certificates for workers' compensation, public liability, and property damage liability insurance, and such other insurance coverages as may be required by specifications and addenda thereto, in at least the following minimum amounts with specification amounts to prevail if greater than minimum amounts indicated. Notwithstanding any other provision of the Contract, the CONTRACTOR shall provide the minimum limits of liability insurance coverage as follows:

Auto Liability	\$1,000,000	Combined Single Limit
General Liability	\$2,000,000	Aggregate (Per Project)
	\$2,000,000	Products Aggregate
	\$1,000,000	Any One Occurrence
	\$1,000,000	Personal Injury
	\$ 300,000	Fire Damage/Legal
Additional Umbrella Liability	\$2,000,000	Occurrence / Aggregate

CONTRACTOR shall furnish an original Certificate of Insurance indicating, and such policy providing coverage to, City of Key West named as an additional insured on all policies—excepting Professional Liability—on a PRIMARY and NON CONTRIBUTORY basis utilizing an ISO standard endorsement at least as broad as CG 2010 (11/85) or its equivalent, (combination of CG 20 10 07 04 and CG 20 37 07 04, providing coverage for completed operations, is acceptable) including a waiver of subrogation clause in favor of City of Key West on all policies. CONTRACTOR will maintain the Professional Liability, General Liability, and Umbrella Liability insurance coverages summarized above with coverage continuing in full force including the additional insured endorsement until at least 3 years beyond completion and delivery of the work contracted herein.

Notwithstanding any other provision of the Contract, the CONTRACTOR shall maintain complete workers' compensation coverage for each and every employee, principal, officer, representative, or agent of the CONTRACTOR who is performing any labor, services, or material under the Contract. Further, CONTRACTOR shall additionally maintain the following minimum limits of coverage:

Bodily Injury Each Accident	\$1,000,000
Bodily Injury by Disease Each Employee	\$1,000,000
Bodily Injury by Disease Policy Limit	\$1,000,000

If the work is being done on or near a navigable waterway, CONTRACTOR's workers compensation policy shall be endorsed to provide USL&H Act (WC 00 01 06 A) and Jones Act (WC 00 02 01 A) coverage if specified by the City of Key West. CONTRACTOR shall provide the City of Key West with a Certificate of Insurance verifying compliance with the workman's compensation coverage as set forth herein and shall provide as often as required by the City of Key West such certification which shall also show the insurance company, policy number, effective and expiration date, and the limits of workman's compensation coverage under each policy.

CONTRACTOR's insurance policies shall be endorsed to give 30 days written notice to the City of Key West in the event of cancellation or material change, using form CG 02 24, or its equivalent.

Certificates of Insurance submitted to the City of Key West will not be accepted without copies of the endorsements being requested. This includes additional insured endorsements, cancellation/ material change notice endorsements, and waivers of subrogation. Copies of USL&H Act and Jones Act endorsements will also be required if necessary. PLEASE ADVISE YOUR INSURANCE AGENT ACCORDINGLY.

CONTRACTOR will comply with any and all safety regulations required by any agency or regulatory body including but not limited to OSHA. CONTRACTOR will notify City of Key West immediately by telephone at (305) 809-3811 any accident or injury to anyone that occurs on the jobsite and is related to any of the work being performed by the CONTRACTOR

ARTICLE 34 "BUILDERS RISK ALL RISK INSURANCE"

Builders Risk All Risk Insurance is not required as part of this contract.

PART 4
TECHNICAL SPECIFICATIONS AND
DRAWINGS

CITY OF KEY WEST POLICE DEPARTMENT

1600 NORTH ROOSEVELT BOULEVARD

WINDOW REPLACEMENT

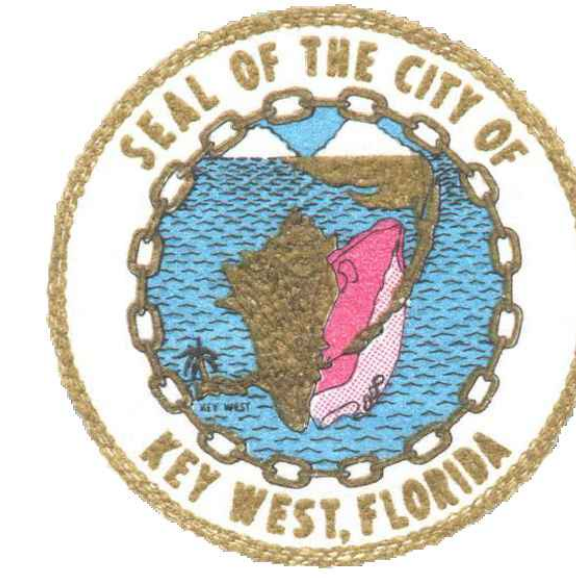

WILLIAM P. HORN
ARCHITECT, P.A.

915 EATON ST.
KEY WEST,
FLORIDA
33040

TEL. (305) 296-8302
FAX (305) 296-1033

LICENSE NO.
AA 0003040

KEY WEST
POLICE DEPARTMENT
WINDOW
REPLACEMENT
1600 NORTH ROOSEVELT BLVD.
KEY WEST, FL.

KEY WEST CITY COMMISSIONERS

MAYOR CRAIG CATES

COMMISSIONER JIMMY WEEKLEY, DISTRICT I
COMMISSIONER MARK ROSSI, DISTRICT II
COMMISSIONER BILLY WARDLOW, DISTRICT III
COMMISSIONER TONY YANIZ, DISTRICT IV
COMMISSIONER TERI JOHNSTON, DISTRICT V
COMMISSIONER CLAYTON LOPEZ, DISTRICT VI
CITY MANAGER BOB VITAS

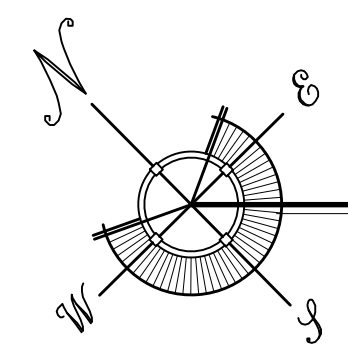
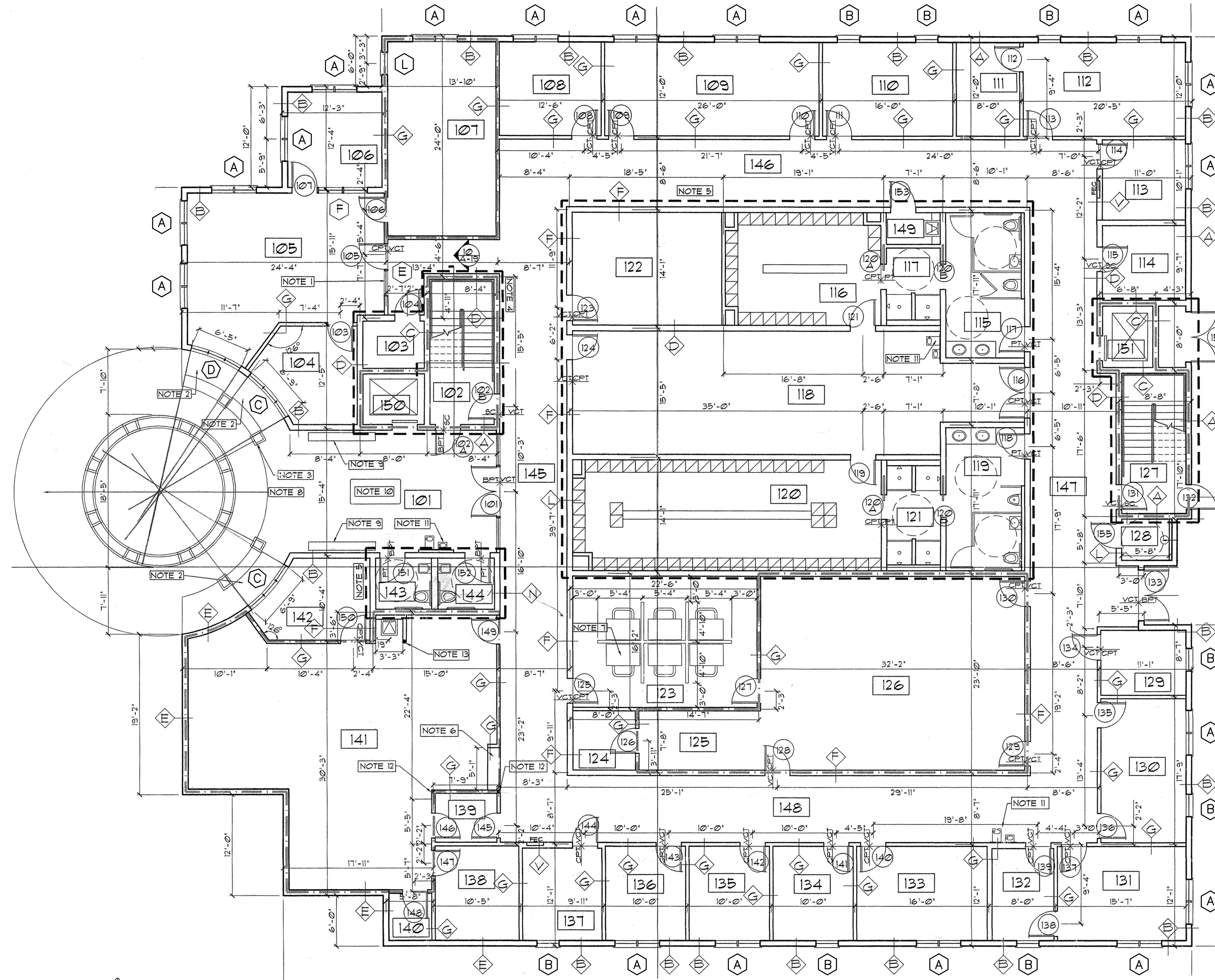

1st FLOOR PLAN

PLAN INFORMATION BASED ON THE BUILDINGS ORIGINAL
CONSTRUCTION DRAWINGS DATE 01-17-2000
PROVIDED BY THE CITY FOR USE.

SCALE : 1/8" = 1'-0"

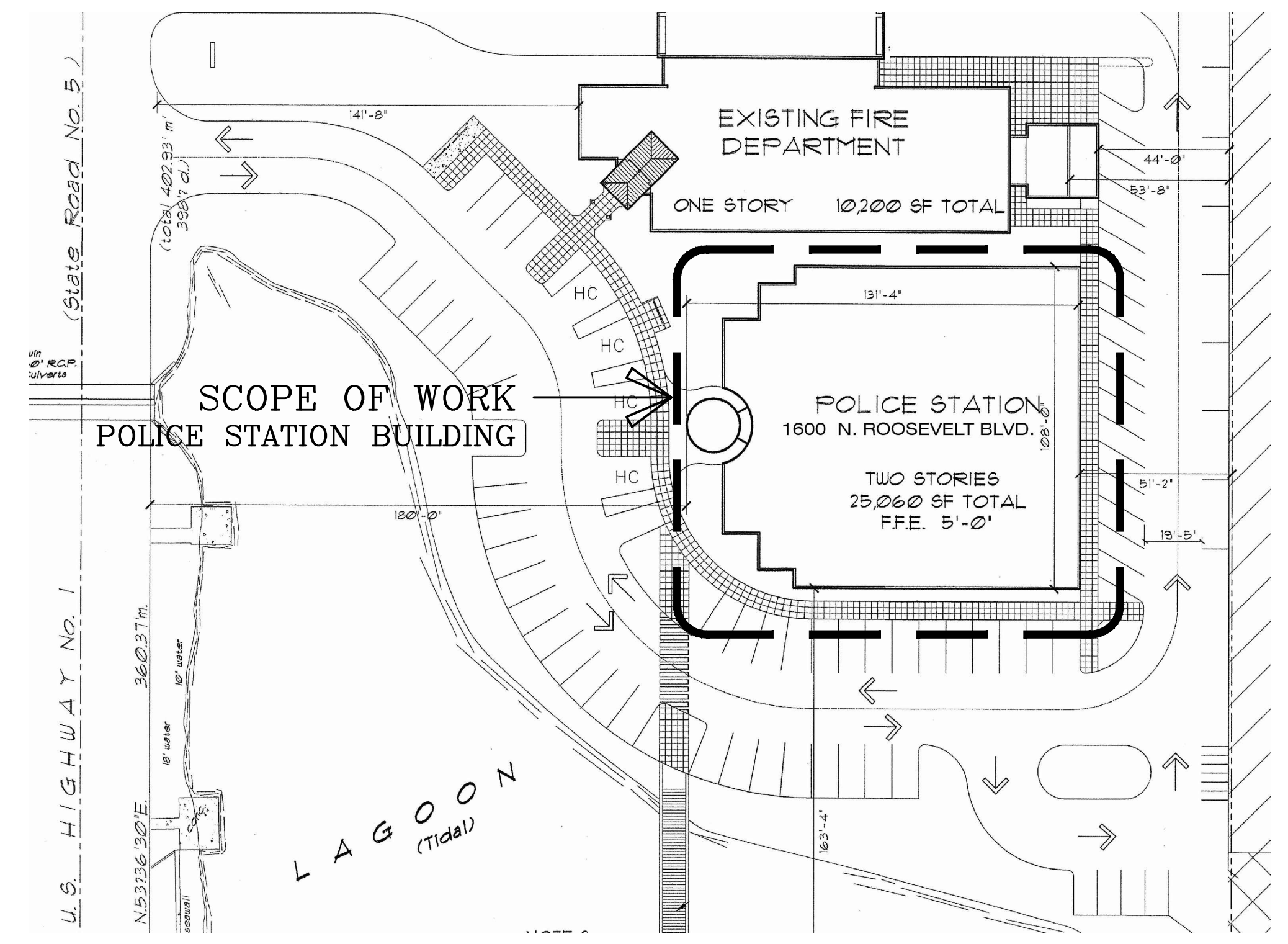

SITE PLAN

SCALE : 1" = 40'-0"

SHEET INDEX

- A-1 COVER SHEET - FIRST FLOOR PLAN
- A-2 SECOND FLOOR PLAN - SCHEDULE - DETAILS
- A-3 ELEVATIONS - DETAILS
- A-4 SPECIFICATIONS
- A-5 SPECIFICATIONS

DESIGN CRITERIA FOR WINDOW REPLACEMENT

FLORIDA BUILDING CODE 2010; RISK CATEGORY IV; EXPOSURE D
AND ULTIMATE WIND SPEED = 200 MPH

SEAL

THESE DRAWINGS MAY
NOT BE REPRODUCED
WITHOUT WRITTEN
AUTHORIZATION BY
WILLIAM P. HORN

DATE
03-15-13 REVIEW
04-15-13 CD's

REVISIONS

DRAWN BY

PROJECT
NUMBER
1304

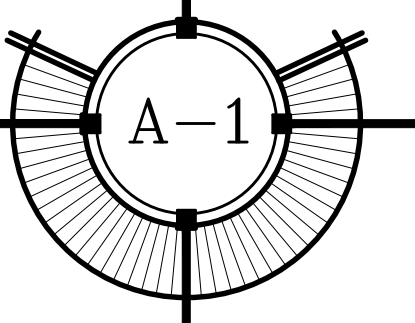

WINDOW SCHEDULE												
MARK	SIZE (FIELD VERIFY)	QUANTITY (VERIFY)	ALUMINUM PREFINISH WHITE	WIND LOAD CORNER 20-19-0	WIND LOAD FIELD	HEAD	JAMB	SILL	REMARKS	MANUFACTURE	N.O.A.	
A	6'-0"X4'-0"	43		+58.6	-75.8	-63.8	2	4&5	3	SINGLE HUNG - PAIR	PGT INDUSTRIES SERIES SH 800	11-1222.04
B	3'-0"X4'-0"	11		+61.4	-81.4	-66.5	2	4&5	3	SINGLE HUNG	PGT INDUSTRIES SERIES SH 800	11-1222.04
C	7'-0"X4'-0"	2		+58.6	-63.8	2	4	3	FIXED GLAZING W/ SLIDING SERVICE WINDOW	PGT INDUSTRIES SERIES 820 AND HR 810	08-0429.08 12-0718.06	
D	6'-4"X4'-0"	1		+58.6	-63.8	2	4	3	FIXED GLAZING W/ SLIDING SERVICE WINDOW	PGT INDUSTRIES SERIES 820 AND HR 810	08-0429.08 12-0718.06	
H	(3)2'-5"X4'-0"	2		+58.6	-63.8	2	4	3	2 FIXED & 1 SINGLE HUNG	PGT INDUSTRIES SERIES SH 800 AND 820	11-1222.04 08-0429.08	
J	(4)2'-10"X4'-0"	1		+57.0	-62.2	2	4	3	2 FIXED & 2 SINGLE HUNG	PGT INDUSTRIES SERIES SH 800 AND 820	11-1222.04 08-0429.08	
L	2'-8"X4'-0"	2		+61.4	-81.4	-63.8	2	4&5	3	SINGLE HUNG	PGT INDUSTRIES SERIES 800	11-1222.04
M	±5'-0"X4'-0"	1		+58.6	-63.8	-63.8	2	4&5	3	SINGLE HUNG - PAIR	PGT INDUSTRIES SERIES 800	11-1222.04

NOTE: ALL MASONRY OPENING SIZES AS WELL AS WINDOW TYPE, SIZE AND QUANTITIES TO BE FIELD VERIFIED BY CONTRACTOR PRIOR TO ANY NEW WORK OR FABRICATION. A FULL SHOP DRAWING SUBMITTAL IS REQUIRED INCLUDING DETAILS OF INSTALLATION AND N.O.A. COMPLIANCE WITH LISTED WIND LOAD REQUIREMENTS. FLORIDA BUILDING CODE 2010; RISK CAT. IV; EXPOSURE 'D'; ULTIMATE WIND SPEED 200 MPH. BASIS OF DESIGN WINDOW ARE PGT SERIES 800 WITH FLANGED FRAME, PREFINISHED ALUMINUM, WHITE. EQUAL PRODUCTS BY OTHER SUBJECT TO THE SAME SPECIFICATIONS AND THERE OWN N.O.A. REQUIREMENTS

NOTE: THIS ROOM CONTAINS DISPATCH OPERATIONS, CONTAINS ELECTRONIC EQUIPMENT AND IS IN OPERATION 24 HOURS PER DAY. COORD. VERY LIMITED ACCESS W/ OWNER. PROVIDE TEMPORARY PLY WD. SEALS AT WINDOWS AND MAXIMIZE WORK PERFORMED FROM THE EXTERIOR. CONTROL DUST AND NOISE TO THE MAX. EXTENT POSSIBLE. SEE GENERAL NOTES SHEET A-3

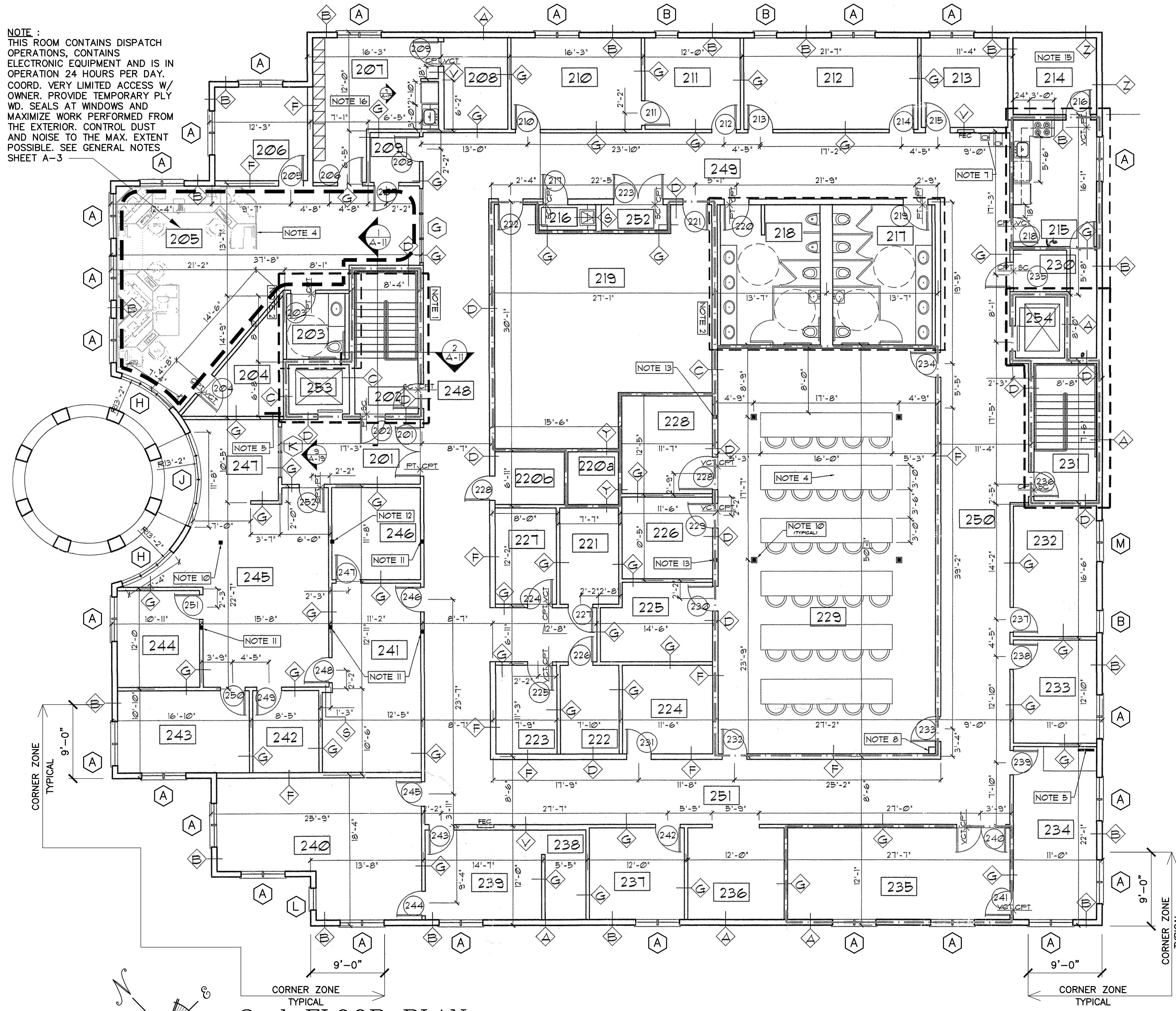

2nd FLOOR PLAN

PLAN INFORMATION BASED ON THE BUILDING'S ORIGINAL CONSTRUCTION DRAWINGS DATED 01-17-2000 PROVIDED BY THE CITY FOR USE. SCALE: 1/8" = 1'-0"

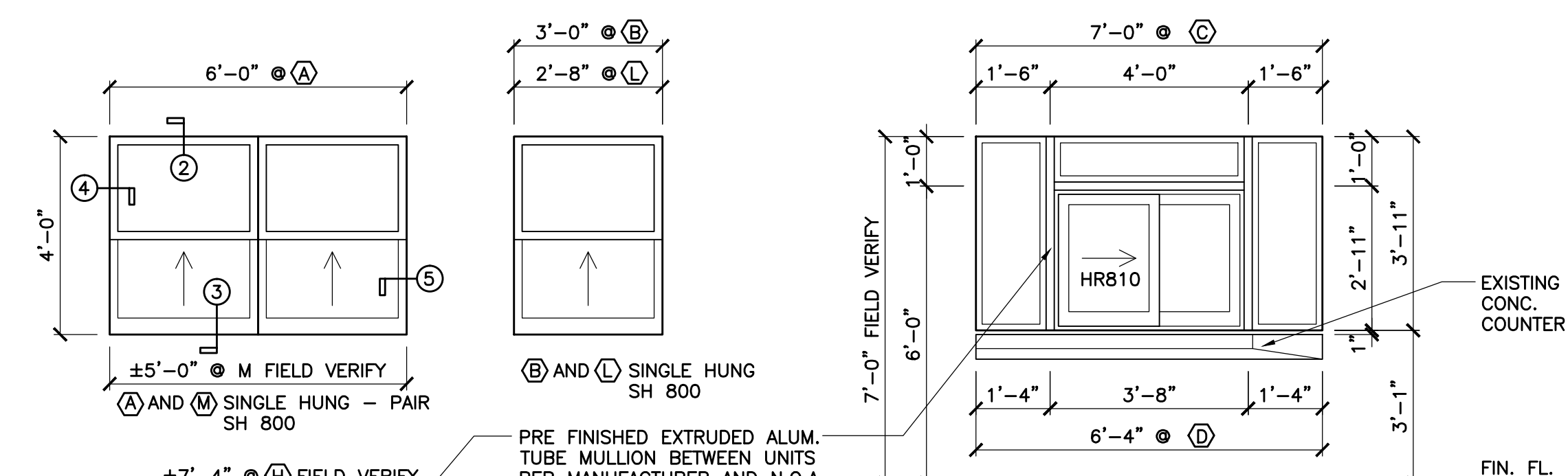

PRE FINISHED EXTRUDED ALUM. TUBE MULLION BETWEEN UNITS PER MANUFACTURER AND N.O.A. REQUIREMENTS. NOTE: AT SEGMENTED INSTALLATIONS IN CURVED WALLS, A WEDGE SHAPED EXTRUDED TUBE IS REQUIRED. DETAIL AND N.O.A. TO BE INCLUDED IN SHOP DRAWING SUBMITTAL.

TYPE C AND D FIXED - 820 AND SLIDING HR-810
NOTE: MASONRY OPENING IS IN CURVED WALL. SEGMENTED INSTALLATION OUTSIDE WALL RADIUS = 13'-2"

NOTE: NEW WINDOW BASIS OF DESIGN IS PGT SERIES 800 INCLUDING SINGLE HUNG, FIXED AND HORIZ. ROLLING WINDOWS. ALL TO BE PRE-FINISHED WHITE. SEE SPECIFICATION SECTION 08100

ALL GLAZING IS LAMINATED FOR IMPACT (LARGE AND SMALL MISSEL) AND SHALL BE LOW-E FOR ENERGY CONSERVATION. SEE SPECIFICATION SECTION 08100-2.3

WINDOW INSTALLATIONS ARE BASED ON EXISTING MASONRY OPENINGS WITH A MAXIMUM 1" BUCK THICKNESS (3/4" MIN.) AND 1/4" SHIM SPACE ALL AROUND. WINDOWS SHALL BE FABRICATED WITHIN THESE SIZE LIMITATIONS WHETHER STANDARD OR CUSTOM SIZES ARE REQUIRED.

WINDOW ELEVATIONS

SCALE: 3/8" = 1'-0"

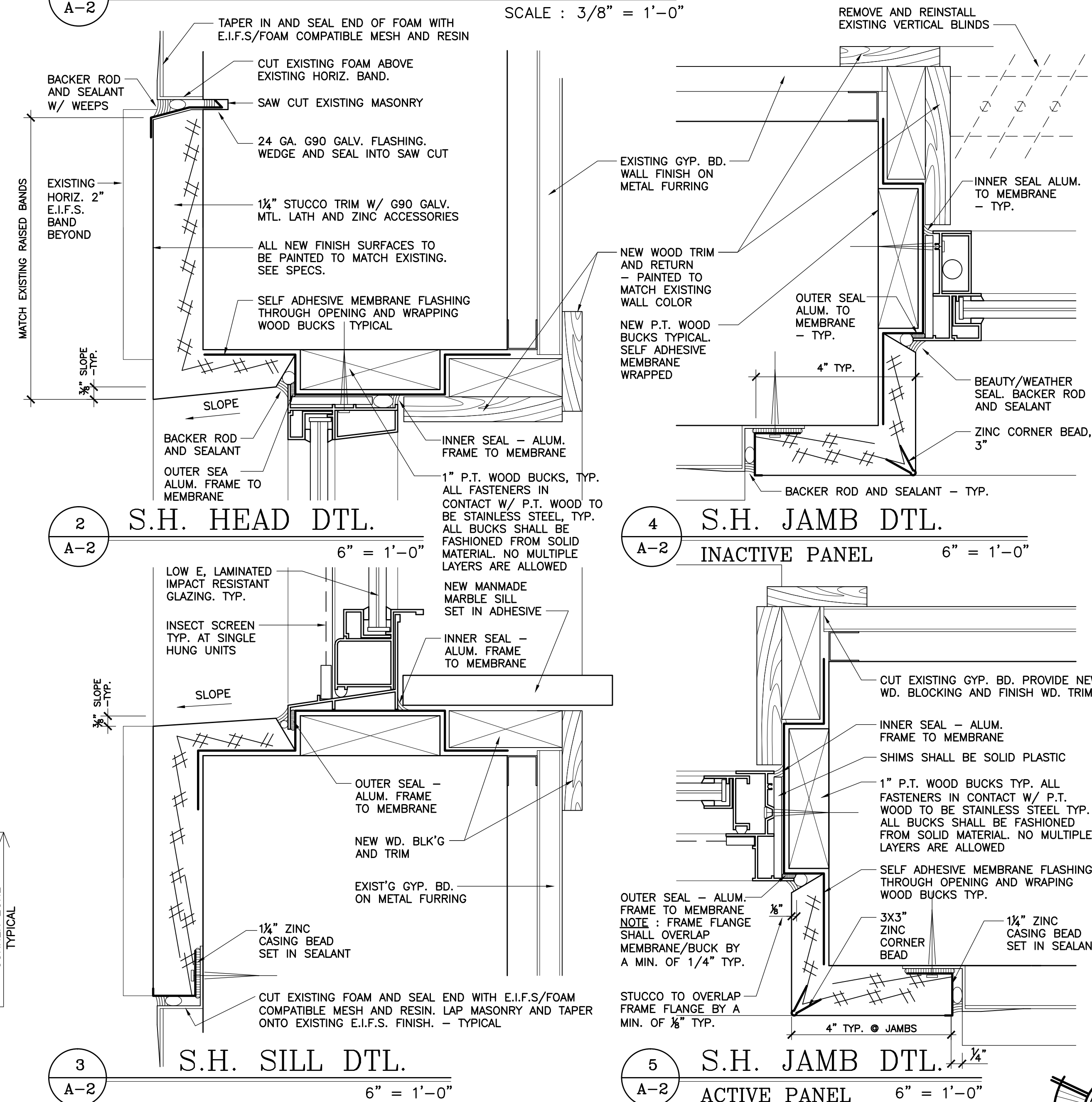

WILLIAM P. HORN
ARCHITECT, P.A.
915 EATON ST.
KEY WEST,
FLORIDA
33040
TEL. (305) 296-8302
FAX (305) 296-1033
LICENSE NO.
AA 000340

GARLAND WILSON
PROFESSIONAL ENGINEER
4460 NORTHSORE DRIVE
PORT CHARLOTTE,
FLORIDA, 33980
FLORIDA LICENCE NO. 41526

KEY WEST
POLICE DEPARTMENT
WINDOW
REPLACEMENT
1600 NORTH ROOSEVELT BLVD.
KEY WEST, FL.

THESE DRAWINGS MAY NOT BE REPRODUCED WITHOUT WRITTEN AUTHORIZATION BY WILLIAM P. HORN

DATE
03-15-13 REVIEW
04-15-13 CD's

REVISIONS

DRAWN BY

PROJECT NUMBER
1304

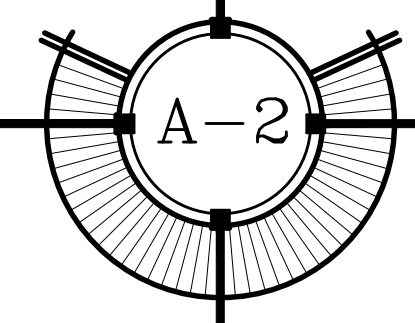

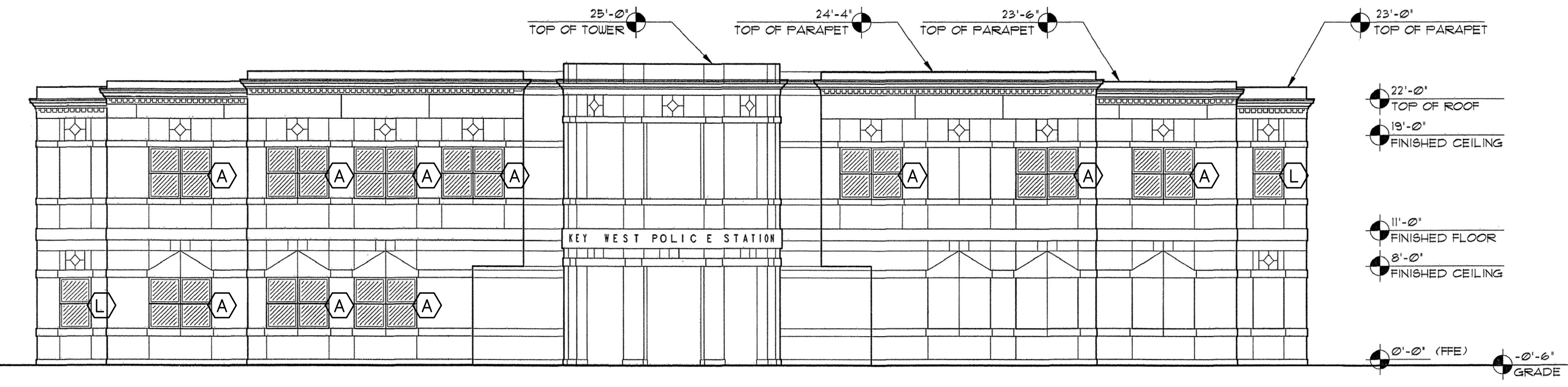

1 FRONT ELEVATION (NORTH WEST)
A-3
SCALE : 1/8" = 1'-0"

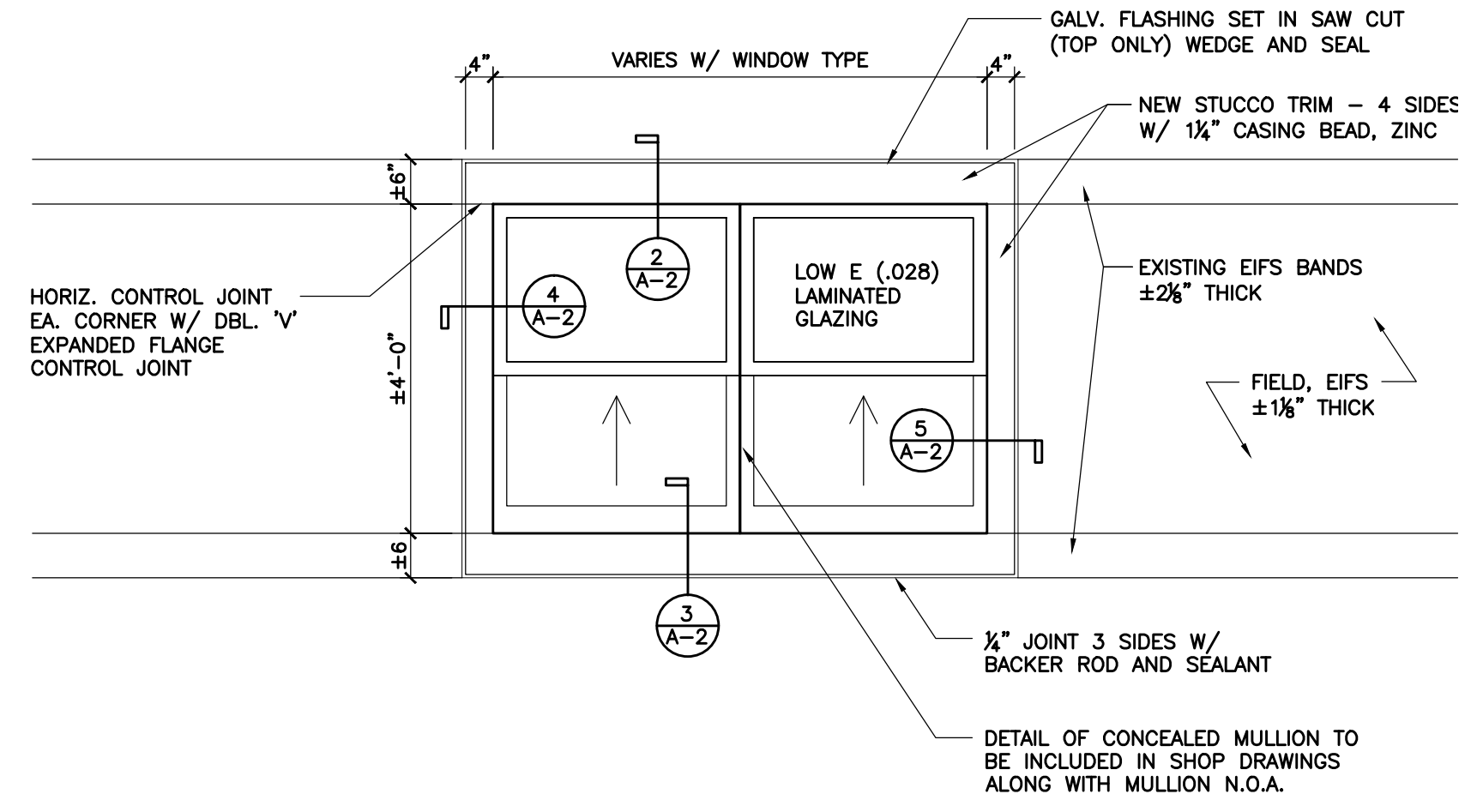

5 WINDOW ELEVATION
A-3
SCALE : 1/2" = 1'-0"

GENERAL NOTES :

- THE CURRENT WORK INVOLVES THE REPLACEMENT OF ALL EXISTING WINDOWS WITHIN THIS BUILDING. THIS WORK IS UNDERTAKEN BECAUSE THE EXISTING WINDOWS HAVE FAILED, PRIMARILY DUE TO IMPROPER INSTALLATION. THE CURRENT WORK WILL BE SUBJECT TO RIGOROUS INSPECTION AND SHALL BE FIELD TESTED FOR AIR INFILTRATION AND WATER RESISTANCE PER STANDARDS OF SPECIFICATION SECTION 08100-1.4-C&D BY AN INDEPENDENT TESTING AGENCY RETAINED BY THE OWNER. TESTING WILL TAKE PLACE AT 3 PHASES OF CONSTRUCTION :
FIRST, AFTER TEN WINDOWS HAVE BEEN INSTALLED (5 @ 1st FLOOR AND 5 @ 2nd FLOOR), ALL WILL BE TESTED IF ANY WINDOW FAILS THE CAUSE WILL BE DETERMINED BY THE CONTRACTOR AND CORRECTED PRIOR TO PROCEEDING.
SECOND, AFTER 50% OF WINDOWS HAVE BEEN INSTALLED A RANDOM SAMPLING OF 10 WINDOWS WILL BE TESTED (BY OWNER). IF ANY WINDOW FAILS, ALL PREVIOUSLY UNTESTED WINDOWS WILL BE TESTED AT THE CONTRACTORS EXPENSE. CAUSE OF FAILURE (S) WILL BE DETERMINED AND CORRECTED BY THE CONTRACTOR PRIOR TO PROCEEDING.
THIRD, AFTER ALL WINDOWS HAVE BEEN INSTALLED A RANDOM SAMPLING OF 10 WINDOWS WILL BE TESTED (BY OWNER). IF ANY WINDOW FAILS, ALL PREVIOUSLY UNTESTED WINDOWS WILL BE TESTED AT THE CONTRACTORS EXPENSE. CAUSE OF FAILURE (S) WILL BE DETERMINED AND CORRECTED.
- THE SITE AND BUILDINGS, INCLUDING ADJACENT FIRE STATION, WILL BE OCCUPIED AND IN-USE THROUGHOUT THE COURSE OF THE WORK. ACCESS TO THE BUILDING, USE OF LIMITED PARKING, STAGING AREA AND TRAFFIC FOR DELIVERIES ETC. WILL BE COORDINATED WITH THE OWNER.
- PROVISIONS FOR SAFE ACCESS BY THE OWNER AND PUBLIC, TO THE BUILDINGS AND PARKING/DRIVE AND WALKWAYS SHALL BE MAINTAINED THROUGHOUT THE COURSE OF THE WORK. TEMPORARY COVERS AT ENTRIES AND CONSTRUCTION AREA BARRIERS WILL BE REQUIRED.
- NOISE, DUST AND DISRUPTION DUE TO CONSTRUCTION ACTIVITIES IS TO BE KEPT TO A MINIMUM. MOST WORK IS TO BE DONE FROM THE EXTERIOR WITH ALL OPENINGS SECURE AT THE END OF WORK EACH DAY. IT IS INTENDED THAT INDIVIDUAL WINDOWS BE REMOVED AND THE NEW WINDOW INSTALLED IN THE SAME DAY. PREP WORK, INTERIOR AND EXTERIOR CAN BE DONE AHEAD. THE MOST RESTRICTED AREA IS DISPATCH, ROOM 205, WHICH IS IN CONSTANT OPERATION. INTERIOR WORK MUST BE SCHEDULED WITH THE OWNER DURING HOURS OF LEAST ACTIVITY WHICH MAY BE 4AM TO 7AM OR OTHER. WORK AND/OR NOISE IN THE ROOM MAY HAVE TO BE STOPPED AT ANY TIME DUE TO DISPATCH ACTIVITIES. FURNISHINGS AND EQUIPMENT CANNOT BE MOVED TO FACILITATE NEW WORK. THIS ROOM WILL BE DIFFICULT FOR ALL PARTIES INVOLVED.
- INTERIOR WORK SHALL BE LIMITED TO INSTALLATION OF DUST CONTROL MEASURES AND WORK REQUIRED TO ADDRESS INTERIOR FINISHES, AND REMOVE EXISTING INTERIOR BLINDS FOR REINSTALLATION ONCE THE ROOM IS COMPLETE.
REMOVE EXISTING GYP. BD. RETURNS AT HEAD, SILL AND JAMBS. PROVIDE ADDITIONAL WD. BLOCKING AND NEW FINISH WOOD TRIM (PAINTED) TO COVER EXPOSED EDGES OF GYP. BD.
- ALL OPENINGS SHALL BE FIELD MEASURED PRIOR TO ORDERING REPLACEMENT WINDOWS (NOT ALL EXISTING OPENINGS ARE SAME SIZE). ALL DIMENSIONS SHALL BE PROVIDED ON SHOP DRAWINGS. REPLACEMENT WINDOWS SHALL BE ON SITE PRIOR TO REMOVAL OF EXISTING WINDOWS. (PULL INDIVIDUAL WINDOWS AND REPLACE, SAME DAY).
- ALL EXISTING WINDOWS AND OTHER CONSTRUCTION DEBRIS SHALL BE PROPERLY AND LEGALLY DISPOSED OF BY THE CONTRACTOR. RECYCLING IS HIGHLY RECOMMENDED. IN NO EVENT SHALL OLD WINDOWS, TRASH OR DEBRIS BY ALLOWED TO ACCUMULATE ON SITE.

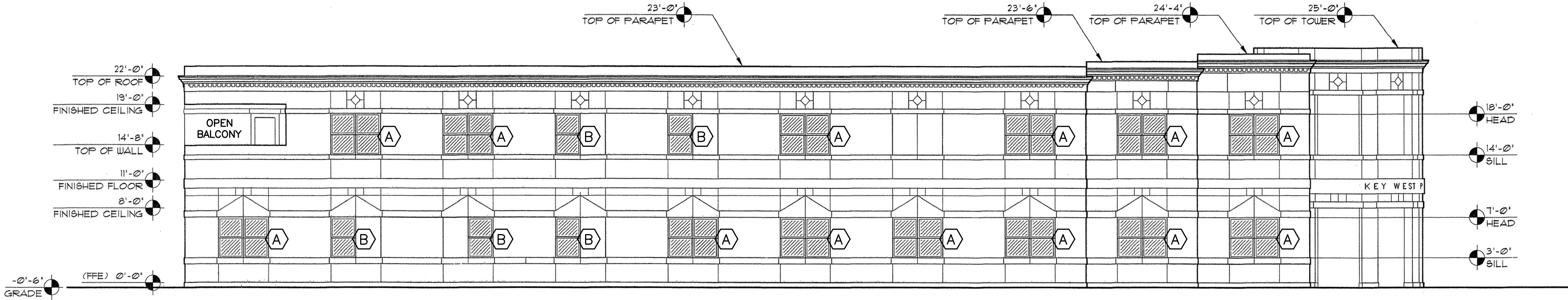

2 SIDE ELEVATION (NORTH EAST)
A-3
SCALE : 1/8" = 1'-0"

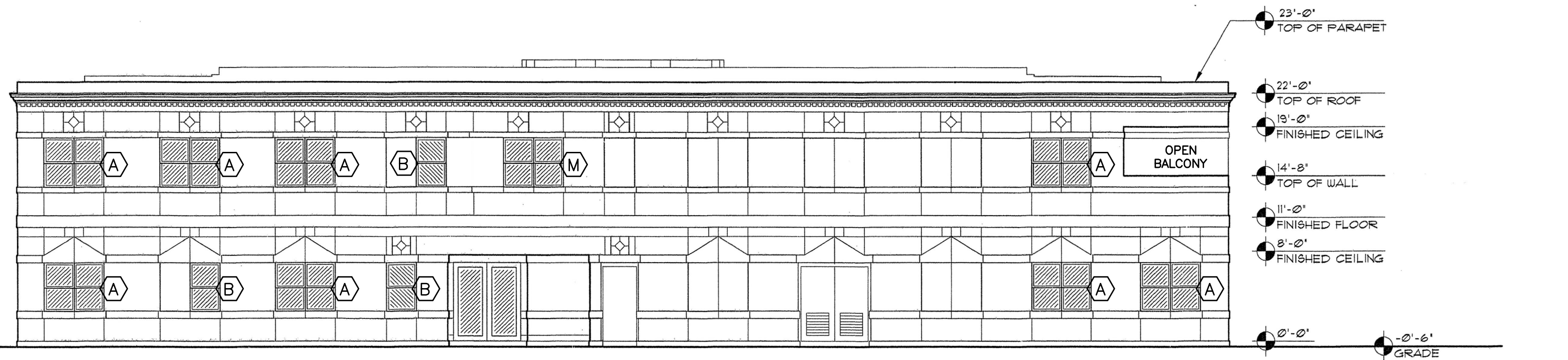

3 REAR ELEVATION (SOUTH EAST)
A-3
SCALE : 1/8" = 1'-0"

EXISTING E.I.F.S. FINISH OVER EXTERNAL FOAM ON CMU AND CONCRETE STRUCTURE. FOAM BASE LAYER 1" THICK WITH BANDING AND TRIM FEATURES BUILT UP WITH ADDITIONAL FOAM. 2 LAYER @ 1" FOR HORIZONTAL BANDING ABOVE AND BELOW WINDOWS.

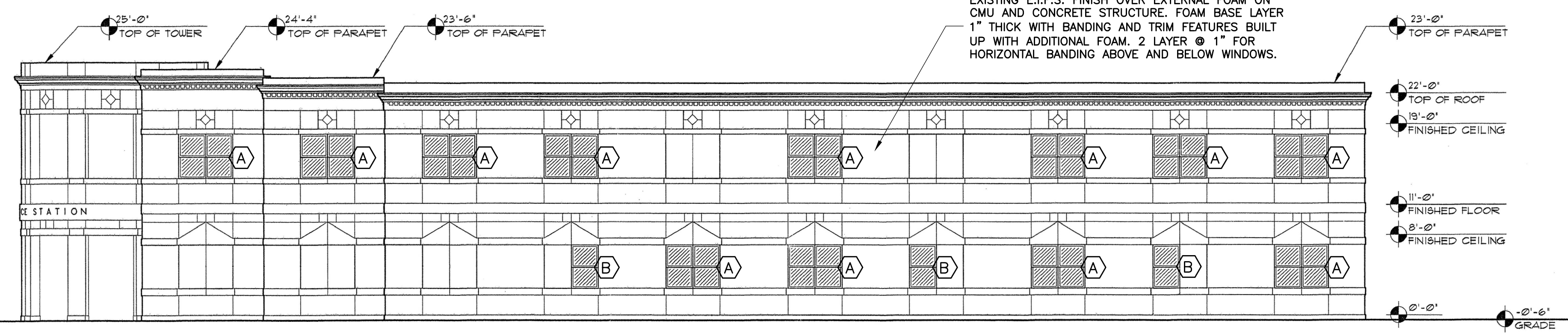

4 SIDE ELEVATION (NORTH EAST)
A-3
SCALE : 1/8" = 1'-0"

ALTERNATES : TO BE INCLUDED IN THE BID, SEE BID FORM

ALTERNATE NO.1	
PROVIDE	3/4" MANMADE MARBLE WINDOW SILLS IN LIEU OF BASE BID WOOD SILLS.
ALTERNATE NO.2	
PROVIDE	WINDOW TYPES C AND D (FIXED GLASS SIDE PANELS WITH SLIDING CENTER WINDOW) WITH BULLET PROOF GLAZING IN LIEU OF THE BASE BID LARGE AND SMALL MISSILE IMPACT GLAZING.
ALTERNATE NO.3	
PROVIDE	ALL WINDOWS AS A FIXED STOREFRONT ASSEMBLY SUCH AS YKK, YHS 50 FS OR EQUAL; EXCEPT THE SLIDING PORTION OF WINDOWS TYPE C AND D. PROVIDE AN ACCESSORY FRAME FLANGE AND MAINTAIN THE BALANCE OF THE INTERIOR AND EXTERIOR INSTALLATION DETAILS. ALL ASSEMBLIES MUST PROVIDE NOA. COMPLIANCE W/ WINDLOADS.
NOTE	THAT WINDOW TYPES H AND J REQUIRE A SEGMENTED INSTALLATION IN A CURVED WALL. GLAZING SHALL REMAIN AS SPECIFIED SECTION 08100.2.3
ALTERNATE NO.4	
CHANGE	THE BASIS OF DESIGN QUALITY STANDARD FOR ALL WINDOW TYPES TO CGI ESTATE SERIES OR EQUAL. GLAZING SHALL REMAIN AS SPECIFIED SECTION 08100.2.3
SINGLE HUNG WINDOWS	- CGI 360.0 (+100 PSF/-209.5 PSF)
HORIZONTAL ROLLING WINDOWS	- CGI 375.0 (+120 PSF/-133 PSF)
FIXED WINDOWS	- CGI 238.0 (+110 PSF/-120 PSF)
(LOAD TESTED IN ACCORDANCE WITH MIAMI-DADE COUNTY PROTOCOLS PA-201 & PA-203)	

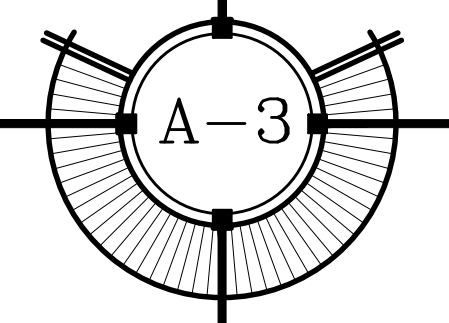

- 1.1 INSECT SCREENS
- A. General: Design windows and hardware to accommodate screens in a tight-fitting, removable arrangement, with a minimum of exposed fasteners and latches. Locate screens on inside of window and provide for each operable exterior sash or ventilator.
- Aluminum Tubular Frame Screens: Comply with SMA 1004, "Specifications for Aluminum Tubular Frame Screens for Windows," Architectural C-24 class.
 - Comply with SMA 1004, "Specifications for Aluminum Tubular Frame Screens for Windows," for minimum standards of appearance, fabrication, attachment of screen fabric, hardware, and accessories unless more stringent requirements are indicated.
- B. Aluminum Wire Fabric: 18-by-16 (1.1-by-1.3-mm) mesh of 0.011-inch- (0.28-mm-) diameter, coated aluminum wire.
- Wire-Fabric Finish: Charcoal gray.
- C. Horizontal Rolling (Service) windows will not be provided with insect screen. Total of three locations.

- 1.2 FABRICATION
- A. General: Fabricate aluminum windows, in sizes indicated and field verify, that comply with AAMA/NWDA 101/I.S.2 for performance class and performance grade indicated. Include a complete system for assembling components and anchoring windows.
- B. Fabricate aluminum windows that are reglazable without dismantling sash or ventilator framing.
- C. Weather Stripping: Provide full-perimeter weather stripping for each operable sash and ventilator.
- D. Weep Holes: Provide weep holes and internal passages to conduct infiltrating water to exterior.
- E. Subframes: Provide subframes with anchors for window units as shown, of profile and dimensions indicated but not less than 0.062-inch- (1.6-mm-) thick extruded aluminum. Miter or cope corners, and weld and dress smooth with concealed mechanical joint fasteners. Finish to match window units. Provide subframes capable of withstanding design loads of window units.
- F. Factory-Glazed Fabrication: Glaze aluminum windows in the factory where practical and possible for applications indicated. Comply with requirements listed under Glazing and AAMA/NWDA 101/I.S.2.
- G. Glazing Stops: Provide snap-on glazing stops coordinated with Division 8 Section "Glazing" and glazing system indicated. Provide glazing stops to match sash and ventilator frames.

- 1.3 FINISHES
- A. General: Comply with NAAMM's "Metal Finishes Manual for Architectural and Metal Products" for recommendations for applying and designating finishes.
- B. Finish designations prefixed by AA comply with the system established by the Aluminum Association for designating aluminum finishes.
- C. High-Performance Organic Finish: AA-C12C42R1x (Chemical Finish: cleaned with inhibited chemicals; Chemical Finish: acid-chromate-fluoride-phosphate conversion coating; Organic Coating: as specified below). Prepare, pretreat, and apply coating to exposed metal surfaces to comply with coating and resin manufacturers' written instructions.
- Fluoropolymer Three-Coat System: Manufacturer's standard three-coat, thermocured system consisting of specially formulated inhibitive primer, fluoropolymer color coat, and clear fluoropolymer topcoat, with both color coat and clear topcoat containing not less than 70 percent polyvinylidene fluoride resin by weight; complying with AAMA 2605.
 - Color and Gloss: White- Semi Gloss

PART 2 - EXECUTION

2.1 EXAMINATION

- A. Examine openings, substrates, structural support, anchorage, and conditions, with Installer present, for compliance with requirements for installation tolerances; rough opening dimensions; levelness of sill plate; coordination with wall flashings, vapor retarders, and other built-in components; operational clearances; and other conditions affecting performance of work.
- Masonry Surfaces: Visibly dry and free of excess mortar, sand, and other construction debris.
 - Metal Surfaces: Dry; clean; free of grease, oil, dirt, rust, corrosion, and welding slag; without sharp edges or offsets at joints.
- B. Proceed with installation only after unsatisfactory conditions have been corrected.
- 2.2 INSTALLATION
- A. General: Comply with manufacturer's written instructions for installing windows, hardware, accessories, and other components; Drawings; and Shop Drawings.
- B. Install windows level, plumb, square, true to line, without distortion or impeding thermal movement, anchored securely in place to structural support, and in proper relation to wall flashing and other adjacent construction.
- C. Set sill members in bed of sealant or with gaskets, as indicated, for weathertight construction.
- D. Install windows and components to drain condensation, water penetrating joints, and moisture migrating within windows to the exterior.
- E. Metal Protection: Separate aluminum and other corrodible surfaces from sources of corrosion or electrolytic action at points of contact with other materials by complying with requirements specified in "Dissimilar Materials" Paragraph in Appendix B in AAMA/NWDA 101/I.S.2.

2.3 FIELD QUALITY CONTROL

- A. Testing Agency: Engage a qualified independent testing and inspecting agency to perform field tests and inspections and to prepare test reports.
- B. Testing Services: Testing and inspecting of installed windows shall take place as follows:
- Testing Methodology: Testing of windows for air infiltration and water resistance shall be performed according to AAMA 502, by applying same test pressures required to determine compliance with AAMA/NWDA 101/I.S.2 in Part 1 "Performance Requirements" Article.
 - Testing Extent: Three windows as selected by Architect and a qualified independent testing and inspecting agency. Windows shall be tested immediately after installation.
 - Test Reports: Shall be prepared according to AAMA 502.
- C. Remove and replace windows where test results indicate that they do not comply with specified requirements.
- D. Additional testing and inspecting, at Contractor's expense, will be performed to determine compliance of replaced or additional work with specified requirements.

2.4 ADJUSTING

- A. Adjust operating sashes and ventilators, screens, hardware, operators, and accessories for a tight fit at contact points and weather stripping for smooth operation and weathertight closure. Lubricate hardware and moving parts.
- 2.5 PROTECTION AND CLEANING
- A. Protect window surfaces from contact with contaminating substances resulting from construction operations. In addition, monitor window surfaces adjacent to and below exterior concrete and masonry surfaces during construction for presence of dirt, scum, alkaline deposits, stains, or other contaminants. If contaminating substances do contact window surfaces, remove contaminants immediately according to manufacturer's written recommendations.
- B. Clean aluminum surfaces immediately after installing windows. Avoid damaging protective coatings and finishes. Remove excess sealants, glazing materials, dirt, and other substances.
- C. Clean factory-glazed glass immediately after installing windows. Comply with manufacturer's written recommendations for final cleaning and maintenance. Remove nonpermanent labels and clean surfaces.
- D. Remove and replace glass that has been broken, chipped, cracked, abraded, or damaged during construction period.

2.6 DEMONSTRATION

- A. Engage a factory-authorized service representative to train Owner's maintenance personnel to adjust, operate, and maintain window operating system. Refer to Division 1 Section "Closeout Procedures."

DIVISION 9 - FINISHES

09220- Stucco - Comply with ASTM C 926 for Portland cement base and finish coat mixes using Portland cement - ASTM C 150, masonry cement, lime - ASTM C 206, and sand ASTM C 897 . Provide min. of three coat system w/scratch coat, brown coat, and finish coat. Finish coat shall consist of 1 part Portland cement, 1-1/2 to 2 parts lime, 3 parts sand. Additional base layers may be applied to achieve desired thickness over expanded metal galvanized lath. Provide control joints as indicated in the details. Provide accessories of high impact poly vinyl chloride, to include stops casing beads, one and two piece control joints (two piece where movement is required) and corner bead. Expanded metal galvanized lath over a membrane air, moisture barrier shall be provided over all non masonry substrates. 09260 - Gypsum Drywall: provide gypsum repairs to existing as shown on drawings or as required by field conditions:

- A. Steel furring channels: ASTM C 645, with flange edges bent back 90 deg. and doubled over to form 3/16 inch minimum lip, minimum thickness of base (uncoated) metal, galvanized finish-typical and minimum depth as follows; thickness is 0.0329 inch, depth is 1-5/8 inch.
- B. Gypsum board: provide 5/8 inches thickness (or match existing adjacent) to comply with ASTM C 840 and ASTM C 36. Use type X for fire-resistance-rated assemblies. Provide tapered edges. Use water - resistant gypsum board (ASTM C 630) where indicated and for all areas subject to moisture including all toilet and bathroom walls and ceilings, janitor room walls and ceilings and the wet wall of a kitchen. Provide galvanized metal trim accessories complying to ASTM C 1047. Provide tape and three coats spackle, screw gypsum board to metal framing.

09900 - Painting - This section includes surface preparation, painting, and finishing of exposed interior and exterior items and surfaces. Surface preparation, priming, and finish coats specified in this section are in addition to shop priming and surface treatment specified under other sections.

- A. Paint exposed surfaces whether or not colors are designated in "schedules", except where a surface or material is specifically indicated not to be painted or is to remain natural. Where an item or surface is not specifically mentioned, paint the same as similar adjacent materials or surfaces. If color or finish is not designated, the architect will select from standard colors or finishes available.
- Painting includes field painting exposed bare and covered pipes and ducts (including color coding), hangers, exposed steel and iron work, and primed metal surfaces of mechanical and electrical equipment.
 - Painting is not required on prefinished items, finished metal surfaces, concealed surfaces, operating parts, and labels.
 - Labels: do not paint over Underwriter's Laboratories, Factory Mutual or other code-required labels or equipment name, identification, performance rating, or nomenclature plates.
- B. Submit Data: Manufacturer's technical information, label analysis, and application instructions for each material proposed for use.
- List each material and cross-reference the specific coating and finish system and application. Identify each material by the manufacturer's catalog number and general classification.
 - Samples for initial color selection in the form of manufacturer's color charts. The exterior will have four colors minimum, one being special order color. The interior will have three colors minimum, one being a special order color.
- C. Provide samples of each color and materials to be applied, with texture to simulate actual conditions, or representative samples of actual substrate. Define each separate coat, including block fillers and primers. Use representative colors when preparing samples for review. Resubmit until required sheen, color, and texture are achieved.
- Provide a list of material and application for each coat of each sample. Label each sample as to location and application.
- D. Paints and coating used on the interior of the building (i.e., inside of the weather proofing system and applied on - site) shall comply with the following criteria:
- Architectural paints, coating and primers applied to interior walls and ceilings: Do not exceed the VOC content limits established in the Green Seal Standard GS-11, Paints, First Edition, May 20, 1993. Primers must meet the VOC limit for non-flat paint. Flats: 50 g/L Non-Flats: 100 g/L
 - Anti-corrosive and anti-rust paints applied to interior ferrous substrates: Do not exceed the VOC content limit of 250 g/L established in Green Seal Standard GS-03, Anti-corrosive Paints, Second Edition, January 7, 1997.
 - Clear wood finishes, floor coatings, stains, primers, and shellacs applied to interior elements must not exceed the VOC content limits established in South Coast Air Quality Management District (SCAQMD) Rule 1113, Architectural Coatings, rules in effect on January 1, 2004.

Provide paint as shown with all materials by Benjamin Moore or equal. Colors and finish shall be selected by owner:

Exterior wood:
Primer:Spot prime Knots & surrounding area w/Bin Schulac (1 coat) Fresh start 100% Acrylic Superior Primer #046, VOC = 44 g/L
Finish:.....Moorgard 100% Acrylic Low Lustre House Paint # N103, VOC = 50 g/L (2 coats)

Exterior stucco or Masonry: (to be painted)
Primer:.....Super Spec Masonry Interior/Exterior 100% Acrylic Masonry Sealer #N066 VOC = 81 g/L . Use Moore's High Build Acrylic Masonry Primer #W068 VOC= 97 g/L for very porous conditions.
Finish:.....(2 coats) Regal select Flat Finish #N400 or Regal select Soft Gloss Finish #N402 VOC = 50 g/L.

Interior wood:
Primer:.....Fresh start 100% Acrylic Superior Primer #046 VOC = 44 g/L. (1 Coat)
Finish:.....Regal Select semi- gloss finish #551 VOC = 38 g/L (2 Coats)

Galvanized metal and Aluminum (Non Ferrous Metal)
Clean surfaces with Super Spec HP oil and grease emulsifier (P83) to remove contaminants
Primer:.....One coat Super Spec HP D.T.M. Acrylic Semi-Gloss #WP29 VOC = 45 g/L
Finish:.....One coat Super Spec HP D.T.M. Acrylic Semi-Gloss #WP29 VOC = 45 g/L

Gypsum Board:
Primer:.....Fresh start 100 % Acrylic Superior Primer #046 VOC = 44 g/L. (1 coat)
Finish:.....2 coats Regal. Select Matte Finish #548 or Flat #547, VOC = 12g/L
Ceilings.....Waterborne Ceiling Paint #508, VOC = 50 g/L (2 coats)

09940 - Existing wood preparation: Contractor to remove and replace all rotted or damaged wood to match existing (use pressure treated wood). Splice in new boards as inconspicuously as possible and stagger joints as required. Scrape all loose paint of existing wood surfaces, sand smooth prior to prime coat paint. (see paint specification). After prime coat, caulk all seams, joints and holes as required prior to finish coats (see sealant specifications).

DIVISION 10 - SPECIALTIES (NOT USED)
DIVISION 11 - EQUIPMENT (NOT USED)
DIVISION 12, 13 , 14, 15 & 16 - NOT USED

WILLIAM P. HORN
ARCHITECT , P.A.

915 EATON ST.
KEY WEST,
FLORIDA
33040

TEL (305) 296-8302
FAX (305) 296-1033

LICENSE NO.
AA 0003040

KEY WEST
POLICE DEPARTMENT
WINDOW
REPLACEMENT
1600 NORTH ROOSEVELT BLVD.
KEY WEST, FL

SEAL

THESE DRAWINGS MAY
NOT BE REPRODUCED
WITHOUT WRITTEN
AUTHORIZATION BY
WILLIAM P. HORN

DATE
03-15-13 REVIEW
04-15-13 CD's

REVISIONS

DRAWN BY

PROJECT NUMBER
1304

