



Historic Architectural Review Commission Staff Report for Item 13

To: Chairman Haven Burkee and Historic Architectural Review
Commission Members

From: Matthew Crawford
Historic Architectural Preservationist

Meeting Date: May 26, 2026

Applicant: Rick Milelli

Application Number: C2026-0029

Address: 618 Duval Street

Description of Work:

Demolition of non-historic storefront.

Site Facts:

The property under review is altered contributing and was built in 1924 per tax assessor data; however this date is incorrect. The property is first visible in the 1912 Sanborn Map. A rear addition was added between 1948-1962. The property contains a 2.5 story commercial building.

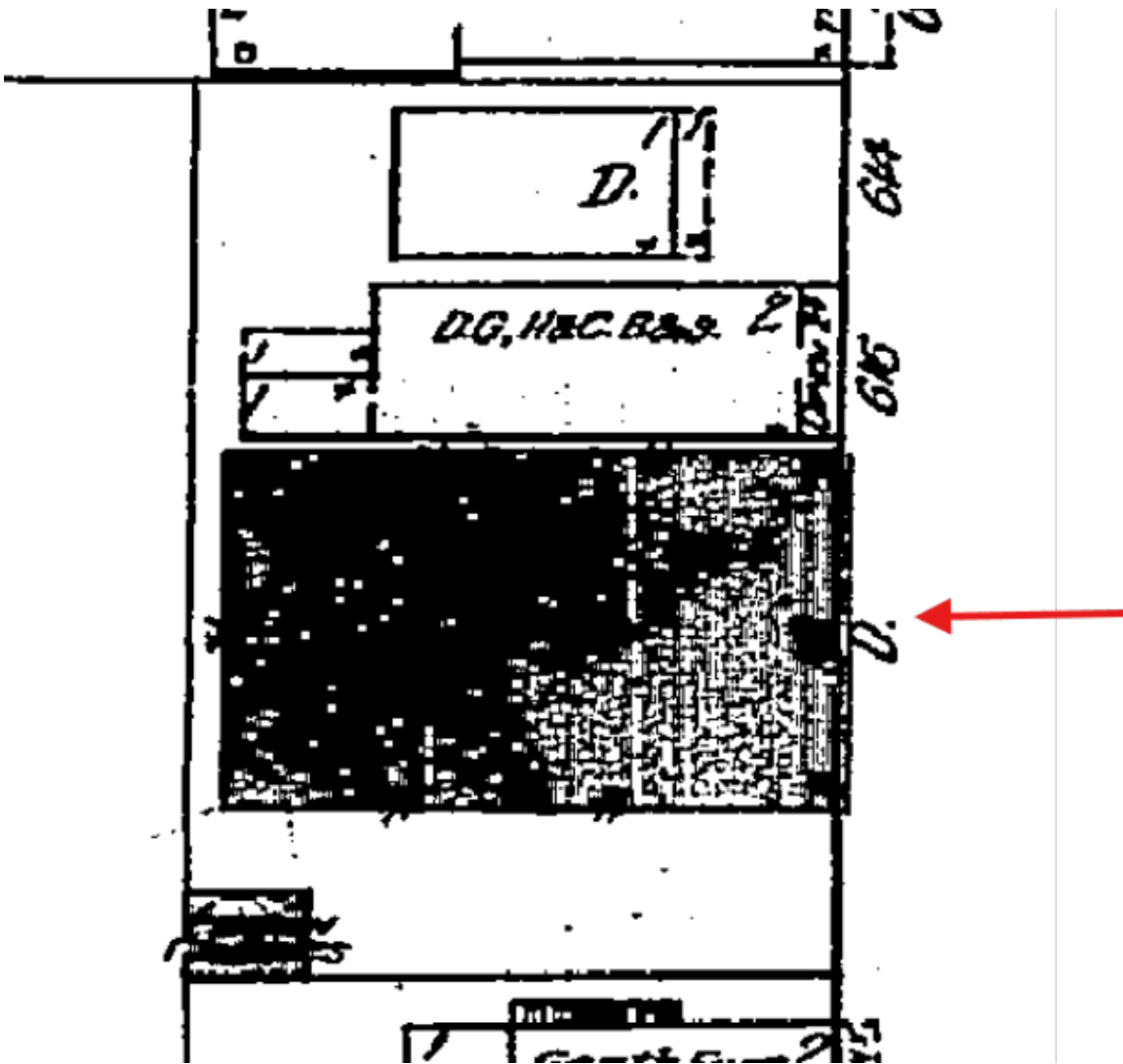

1912 Sanborn Map

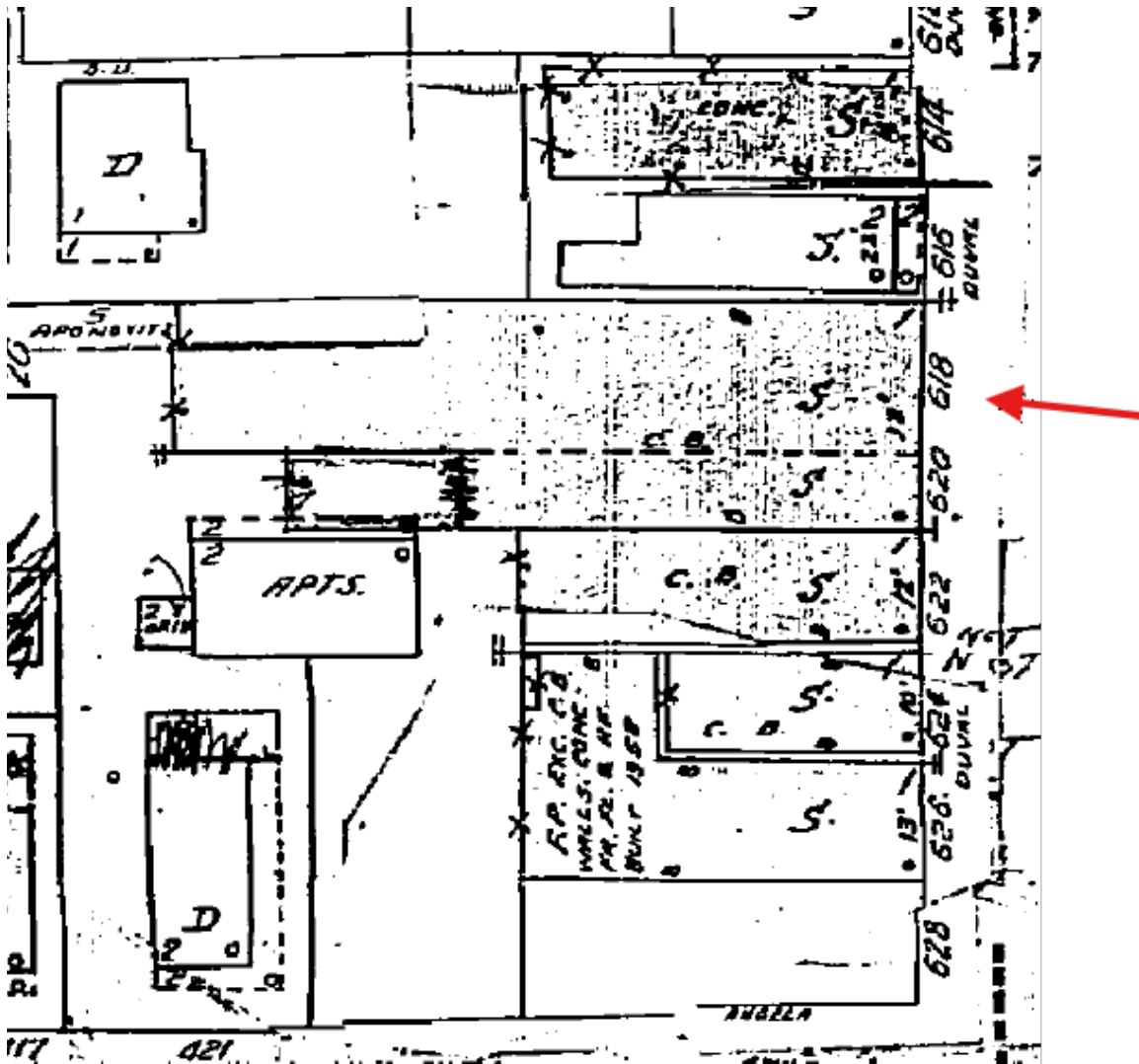



c. 1954 Historic Photo of Property Under Review.



c. 1965 Historic Photo of Property Under Review



c. 1970s Photo of Property Under Review



c. 1980 Photo of Property Under Review



Photo Showing Existing Storefront.



Photo of Property Under Review and Adjacent Structure.



Photo of 619 Duval Street Showing Storefront Similar to Proposed Storefront for 618 Duval Street.

Guidelines Cited on Review:

- Guidelines for Storefronts (pages 29k-29l), specifically guideline 1.
- Guidelines for Entrances, Porches, and Doors (pages 32-33), specifically guideline 5.
- Guidelines for New Construction (pages 38a-38q), specifically guidelines 7, 22, 24, and 25.
- Guidelines for Additions and alterations on contributing structures (pages 37a-37k), specifically guidelines 1, 2, 4, 5 (first sentence), 11 (first sentence), 13, 14, 19, 21, 22, 26 (first sentence), 27, 28, 29, 30, 32, and 33.
- Guidelines for Commercial Storefronts and Signage (page 46), specifically guideline 1.

Ordinances Cited on Review:

- Section 102-217 (3), demolition for non-contributing or non-historic structures of the Land Development Regulations.
- Section 102-218 - Criteria for Demolition of the Land Development Regulations

Staff Analysis:

A Certificate of Appropriateness is currently under review for new 8 foot tall folding doors on the front elevation of 618 Duval Street. This consists of 4 new folding doors that would fold inward into the building. A new beam with wood trim is proposed above the doors and new wood posts are proposed on either side of the folding doors.

Demolition proposes the demolition of the non-historic storefront. Based on the historic photographs, the storefront has changed multiple times. The c. 1954 photo shows a partially recessed storefront with some large glass displays. The c. 1970s photo shows a fully open storefront. The c. 1980 photo shows a partially recessed storefront similar to the c. 1954 photo. Sometime after 1980, the store front was broken into two businesses, with the store front for this project being enclosed with 2 windows and doors.



3
A-1

EXISTING ELEVATION

SCALE: 3/8" = 1'-0"

Existing Storefront Elevation

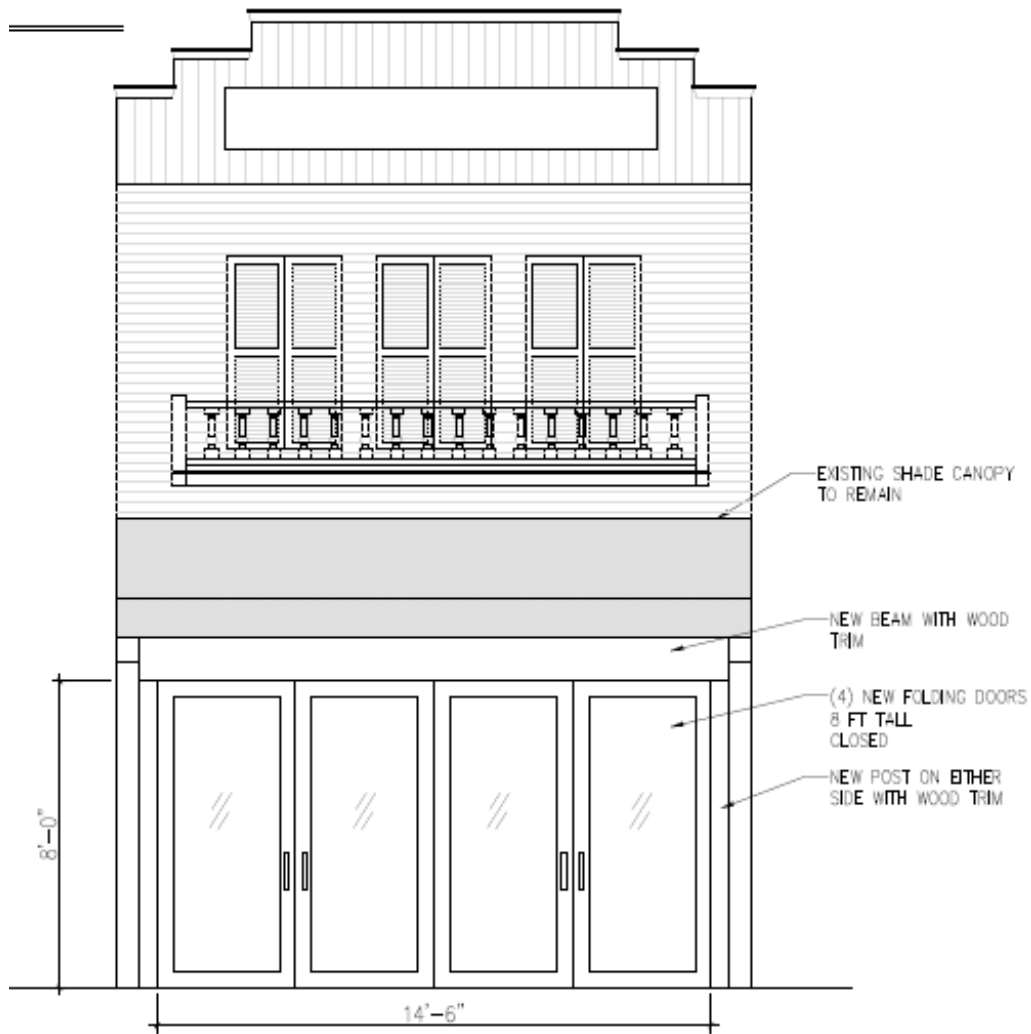

4 PROPOSED ELEVATION (DOORS CLOSED)
 A-1 SCALE: 3/8" = 1'-0"

Proposed Storefront Elevation with Doors Closed

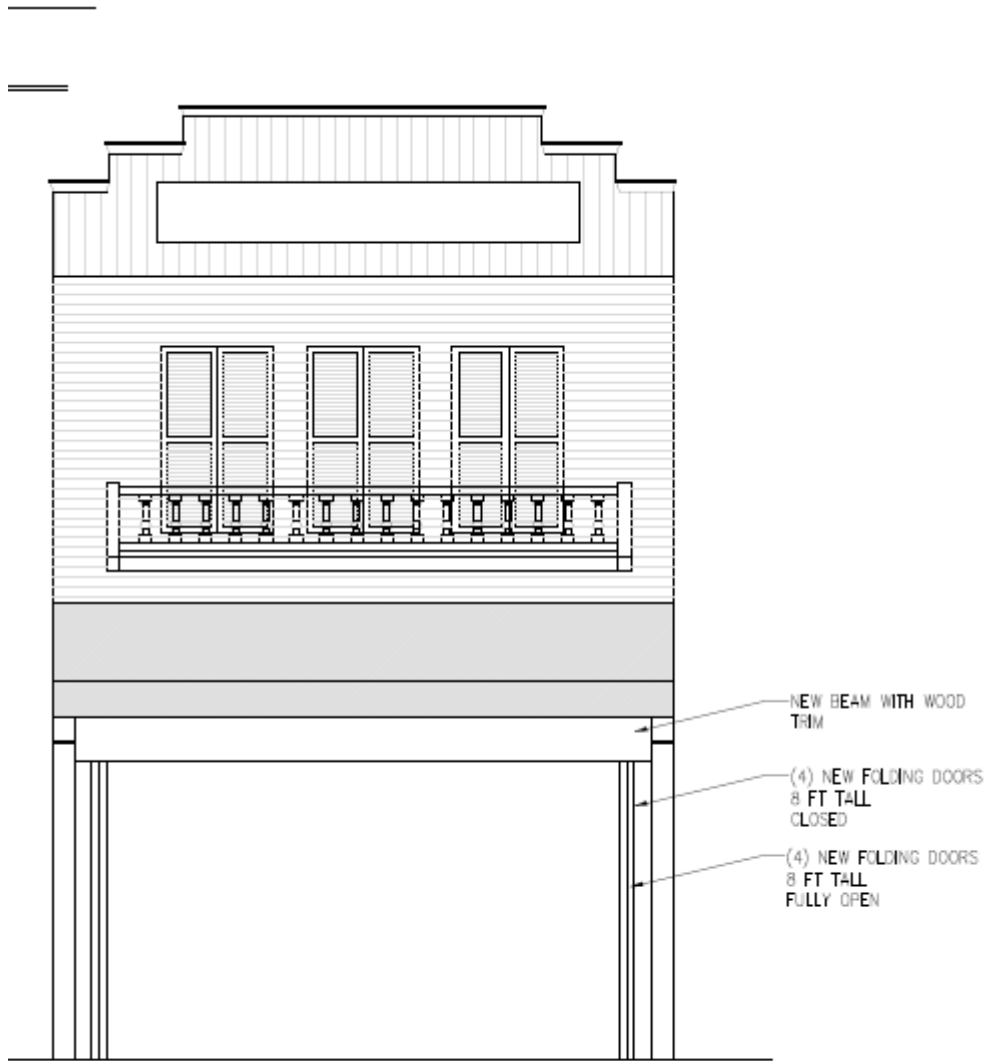

5 PROPOSED ELEVATION (DOORS OPEN)
 4-1 SCALE: 3/8" = 1'-0"

Proposed Storefront Elevation with Doors Open

Consistency with Cited Guidelines:

Staff finds the proposed design generally compatible with the existing structure and with the surrounding commercial context. Guideline 2 of Commercial Storefronts states that “replacement storefronts of buildings built on or prior to 1945 shall match the historic storefront including design, dimensions, and any frame detail profile.” Although the historic storefront at this location featured a recessed entry with large display windows, historic photographs and on-site evidence show that the storefront has been significantly altered over time. Because the façade was subdivided into two separate commercial units after the 1980s, re-establishing the original historic configuration is no longer feasible.

The proposed folding-door system, when opened, would recreate an open storefront condition similar to what is seen in the c.1970s photograph. This approach maintains the historic pattern of open, pedestrian-oriented commercial frontage typical of Duval Street. Guideline 1 of Commercial Storefronts and Signage states that projects must “retain and preserve the functional and decorative elements of historic storefronts including windows, doors, transoms, corner posts, and bulkheads that define historic character.” In this case, all such historic features were removed during earlier alterations, and no original storefront elements remain. For this reason, staff has no objection to the removal of the existing non-historic storefront assembly.

Guideline 1 further notes that “impact resistant storefronts matching dimensions, design and frame details and materials are an acceptable solution as replacements.” While staff believes the original storefront would have utilized wood, the extent of alteration since that time allows for the use of aluminum doors that maintain compatible proportions and detailing.

Staff also notes that tinted or colored glazing on elevations visible from the primary right-of-way is not permitted. If energy efficiency improvements are desired, films with no tint and no reflectivity may be used as an acceptable alternative.

Criteria for Demolition:

Since the first-story bump out under review is non-historic, the evaluation shall be based on section 102-218 (b) of the Land Development Regulations, which requires the following criteria for demolitions:

The historic architectural review commission shall not issue permits that would result in:

(1) Removing buildings or structures that are important in defining the overall historic character of a district or neighborhood so that the character is diminished;

The existing storefront is not historic and does not contribute to the character of the building.

(2) Removing historic buildings or structures and thus destroying the historic relationship between buildings or structures and open space;

The existing storefront is not historic and does not destroy the historic relationship between buildings or structures and open space.

(3) Removing an historic building or structure in a complex; or removing a building facade; or removing a significant later addition that is important in defining the historic character of a site or the surrounding district or neighborhood.

This will not be the case.

(4) Removing buildings or structures that would otherwise qualify as contributing, as set forth in section 102-62(3).

The existing storefront is not historic. Staff opines that the structure would not qualify as contributing in the near future.

In conclusion, it is the staff's opinion that the request for demolition can be considered by the Commission as it meets the criteria for demolition stated under the Land Development Regulations. If the Commission finds the design appropriate this will be the only required reading for demolition.

APPLICATION

HARC MAJOR PROJECTS CERTIFICATE OF APPROPRIATENESS



City of Key West

1300 White Street
Key West, Florida 33040

HARC COA #	REVISION #	INITIAL & DATE
FLOOD ZONE	ZONING DISTRICT	BLDG PERMIT #

A PRE-APPLICATION MEETING WITH HARC STAFF IS REQUIRED PRIOR TO SUBMITTAL

ADDRESS OF PROPOSED PROJECT:	618 DUVAL		
NAME ON DEED:	Old Town Key West Development	PHONE NUMBER	305-294-4142
OWNER'S MAILING ADDRESS:	201 Front St. St. 224	EMAIL	hcasas@historictours.com
	Key West FL		
APPLICANT NAME:	Rick Milelli	PHONE NUMBER	305 481-0100
APPLICANT'S ADDRESS:	13 Bamboo Terr.	EMAIL	nsef1keys@gmail.com
	Key West FL 33040		
APPLICANT'S SIGNATURE:		DATE	4/21/26

ANY PERSON THAT MAKES CHANGES TO AN APPROVED CERTIFICATE OF APPROPRIATENESS MUST SUBMIT A NEW APPLICATION.

FLORIDA STATUTE 837.06: WHOEVER KNOWINGLY MAKES A FALSE STATEMENT IN WRITING AND WITH THE INTENT TO MISLEAD A PUBLIC SERVANT IN THE PERFORMANCE OF HIS OR HER OFFICIAL DUTY SHALL BE GUILTY OF A MISDEMEANOR OF THE SECOND-DEGREE PUNISHABLE PER SECTION 775.082 OR 775.083. THE APPLICANT FURTHER HEREBY ACKNOWLEDGES THAT THE SCOPE OF WORK AS DESCRIBED IN THE APPLICATION SHALL BE THE SCOPE OF WORK THAT IS CONTEMPLATED BY THE APPLICANT AND THE CITY. THE APPLICANT FURTHER STIPULATES THAT SHOULD FURTHER ACTION BE TAKEN BY THE CITY FOR EXCEEDING THE SCOPE OF THE DESCRIPTION OF WORK, AS DESCRIBED HEREIN, AND IF THERE IS CONFLICTING INFORMATION BETWEEN THE DESCRIPTION OF WORK AND THE SUBMITTED PLANS, THE AFOREMENTIONED DESCRIPTION OF WORK SHALL BE CONTROLLING.

PROJECT INCLUDES: REPLACEMENT OF WINDOWS___ RELOCATION OF A STRUCTURE___ ELEVATION OF A STRUCTURE___
 PROJECT INVOLVES A CONTRIBUTING STRUCTURE: YES___ NO___ INVOLVES A HISTORIC STRUCTURE: YES NO___
 PROJECT INVOLVES A STRUCTURE THAT IS INDIVIDUALLY LISTED ON THE NATIONAL REGISTER: YES___ NO___

DETAILED PROJECT DESCRIPTION INCLUDING MATERIALS, HEIGHT, DIMENSIONS, SQUARE FOOTAGE, LOCATION, ETC.	
GENERAL:	Demolish existing storefront system and install (4) folding doors. Doors are 8ft tall and 3'-7 1/2" wide. Glass will be clear. Project includes wood framing for new door system.
MAIN BUILDING:	New folding door system.
DEMOLITION (PLEASE FILL OUT AND ATTACH DEMOLITION APPENDIX):	
Demolish (2) doors, (2) fixed windows, (2) transom windows and wood framing	

APPLICATIONS MUST BE SUBMITTED IN PERSON WITH HARD COPIES BY 3PM ON THE SCHEDULED DEADLINE
 PLEASE SEND AN ELECTRONIC COPY OF ALL DOCUMENTS CITY_HARC@CITYOFKEYWEST-FL.GOV

ACCESSORY STRUCTURE(S): N/A	
PAVERS: N/A	FENCES: N/A
DECKS: N/A	PAINTING:
SITE (INCLUDING GRADING, FILL, TREES, ETC):	POOLS (INCLUDING EQUIPMENT):
N/A	N/A
ACCESSORY EQUIPMENT (GAS, A/C, VENTS, ETC):	OTHER:
N/A	

OFFICIAL USE ONLY:	HARC COMMISSION REVIEW	EXPIRES ON:
MEETING DATE:	<input type="checkbox"/> APPROVED <input type="checkbox"/> NOT APPROVED <input type="checkbox"/> DEFERRED FOR FUTURE CONSIDERATION	INITIAL:
MEETING DATE:	<input type="checkbox"/> APPROVED <input type="checkbox"/> NOT APPROVED <input type="checkbox"/> DEFERRED FOR FUTURE CONSIDERATION	INITIAL:
MEETING DATE:	<input type="checkbox"/> APPROVED <input type="checkbox"/> NOT APPROVED <input type="checkbox"/> DEFERRED FOR FUTURE CONSIDERATION	INITIAL:
REASONS OR CONDITIONS:		
STAFF REVIEW COMMENTS:		
FIRST READING FOR DEMO:	SECOND READING FOR DEMO:	
HARC STAFF SIGNATURE AND DATE:	HARC CHAIRPERSON SIGNATURE AND DATE:	

THIS APPLICATION MAY BE REVIEWED BY PLANNING DEPARTMENT STAFF.

HARC CERTIFICATE OF APPROPRIATENESS: DEMOLITION APPENDIX



City of Key West

1300 White Street
Key West, Florida 33040

HARC COA #	INITIAL & DATE
ZONING DISTRICT	BLDG PERMIT #

ADDRESS OF PROPOSED PROJECT:

618 DUVAL

PROPERTY OWNER'S NAME:

OLD TOWN KEY WEST DEVELOPMENT LTD

APPLICANT NAME:

RICK MILELLI

*I hereby certify I am the owner of record and that the work shall conform to all applicable laws of this jurisdiction. By receiving a Certificate of Appropriateness, I realize that this project will require a Building Permit approval **PRIOR** to proceeding with the work outlined above and that a final inspection is required under this application. I also understand that any changes to an approved Certificate of Appropriateness must be submitted for review.*

X

[Signature]

Edwin O. Swift III

4/8/2026

PROPERTY OWNER'S SIGNATURE

DATE AND PRINT NAME

DETAILED PROJECT DESCRIPTION OF DEMOLITION

REMOVE 1 SET DOUBLE DOORS. 3 TRANSOM WINDOWS AND 2 FIXED WINDOWS. INCLUDES STOREFRONT WOOD FRAMING AROUND DOORS AND WINDOWS

CRITERIA FOR DEMOLITION OF CONTRIBUTING OR HISTORIC STRUCTURES:

Before any Certificate of Appropriateness may be issued for a demolition request, the Historic Architectural Review Commission must find that the following requirements are met (please review and comment on each criterion that applies):

(1) If the subject of the application is a contributing or historic building or structure, then it should not be demolished unless its condition is irrevocably compromised by extreme deterioration or it does not meet any of the following criteria:

(a) The existing condition of the building or structure is irrevocably compromised by extreme deterioration.

(2) Or explain how the building or structure meets the criteria below:

(a) Embodies no distinctive characteristics of a type, period, or method of construction of aesthetic or historic significance in the city and is not a significant and distinguishable building entity whose components may lack individual distinction.

The structure has been altered many times. Historical photos show the storefront had many different configurations. The storefront does not meet any of the criteria listed in 2(a)

Nothing in this application is intended to alter the authority of the Building Official to condemn for demolition dangerous buildings, as provided in Section 102-218 of the Land Development Regulations and Chapter 14 of the Code of Ordinances.

(b) Is not specifically associated with events that have made a significant contribution to local, state, or national history.

The storefront does not meet this criteria

(c) Has no significant character, interest, or value as part of the development, heritage, or cultural characteristics of the city, state or nation, and is not associated with the life of a person significant in the past.

The storefront does not meet this criteria.

(d) Is not the site of a historic event with significant effect upon society.

The storefront does not meet this criteria.

(e) Does not exemplify the cultural, political, economic, social, or historic heritage of the city.

The storefront does not meet this criteria.

(f) Does not portray the environment in an era of history characterized by a distinctive architectural style.

The storefront does not meet this criteria

(g) If a part of or related to a square, park, or other distinctive area, nevertheless should not be developed or preserved according to a plan based on the area's historic, cultural, natural, or architectural motif.

It isn't

(h) Does not have a unique location or singular physical characteristic which represents an established and familiar visual feature of its neighborhood or of the city, and does not exemplify the best remaining architectural type in a neighborhood.

It does. not.

Nothing in this application is intended to alter the authority of the Building Official to condemn for demolition dangerous buildings, as provided in Section 102-218 of the Land Development Regulations and Chapter 14 of the Code of Ordinances.

(i) Has not yielded, and is not likely to yield, information important in history,
<i>It has not.</i>

CRITERIA FOR DEMOLITION OF NON-CONTRIBUTING OR NON-HISTORIC STRUCTURES:
The following criteria will also be reviewed by the Historic Architectural Review Commission for proposed demolitions. The Commission shall not issue a Certificate of Appropriateness that would result in the following conditions (please review and comment on each criterion that applies):
(1) Removing buildings or structure that are important in defining the overall historic character of a district or neighborhood so that the character is diminished.
(2) Removing historic buildings or structures and thus destroying the historic relationship between buildings or structures and open space.
(3) Removing an historic building or structure in a complex; or removing a building façade; or removing a significant later addition that is important in defining the historic character of a site or the surrounding district or neighborhood.
(4) Removing buildings or structures that would otherwise qualify as contributing.

SANBORN MAPS

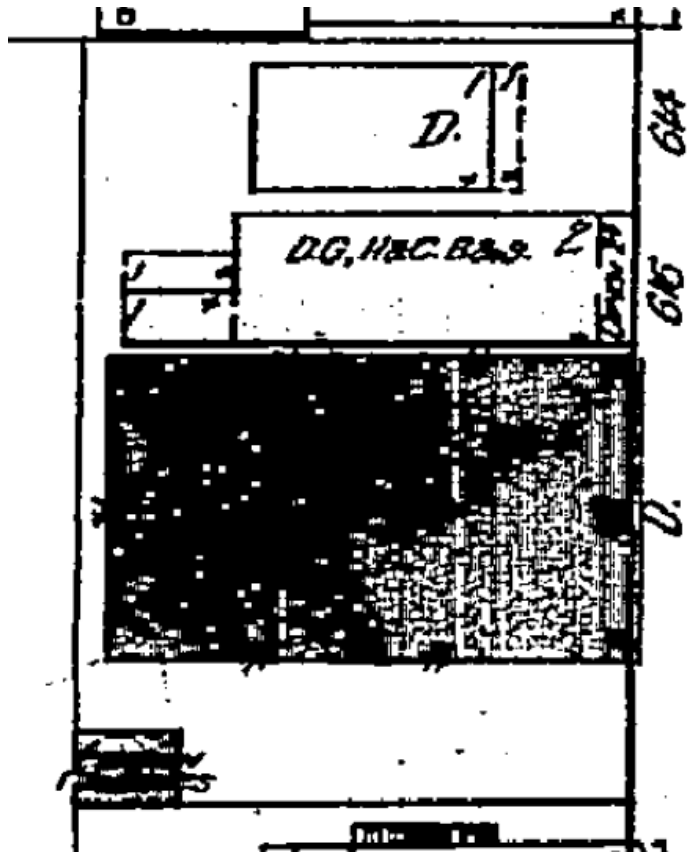

1912 Sanborn Map

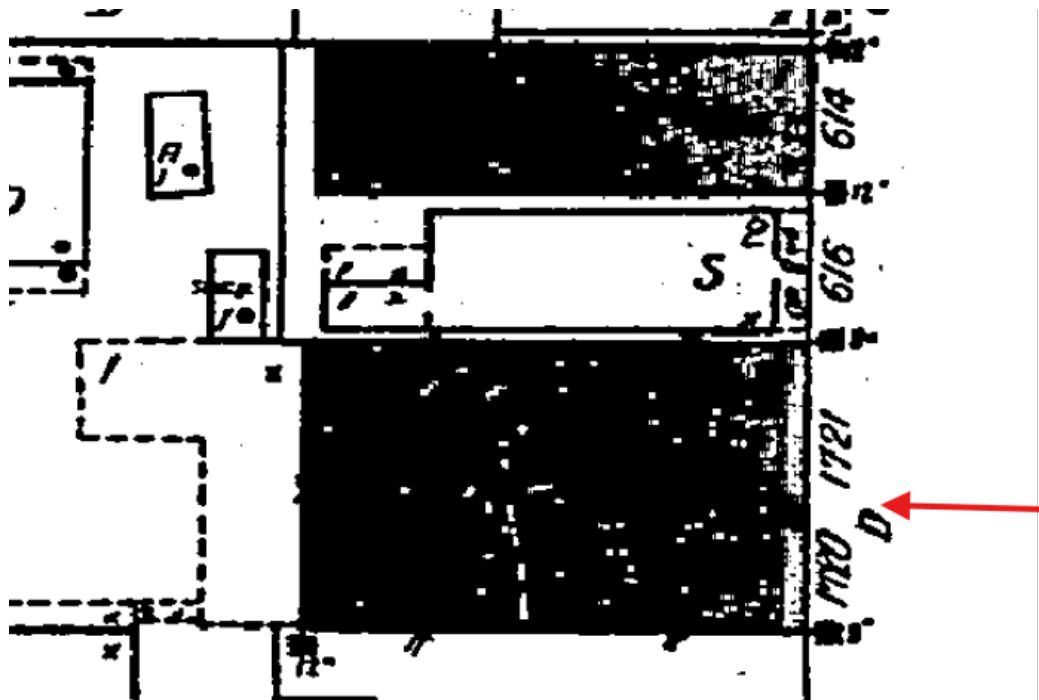

1926 Sanborn Map

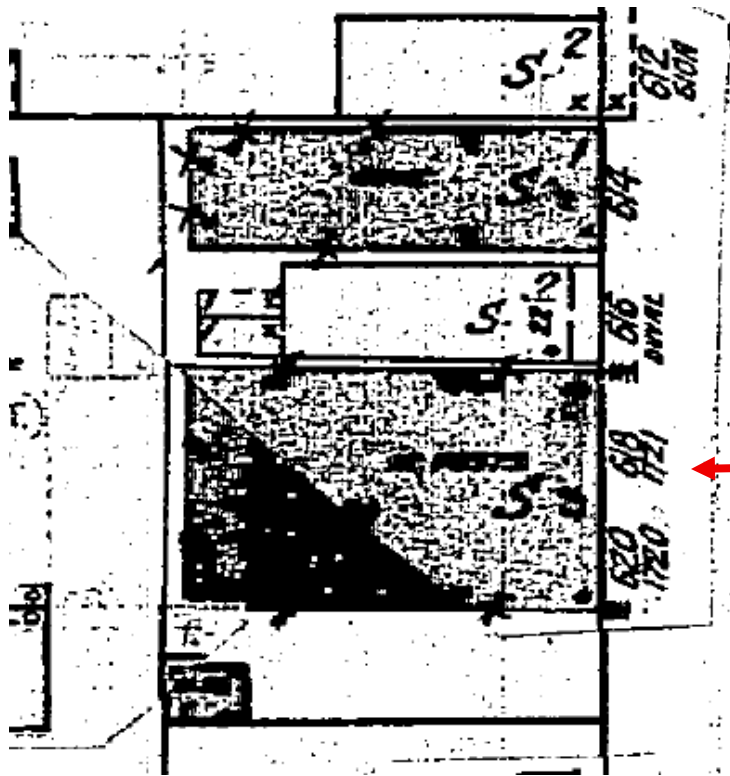

1948 Sanborn Map

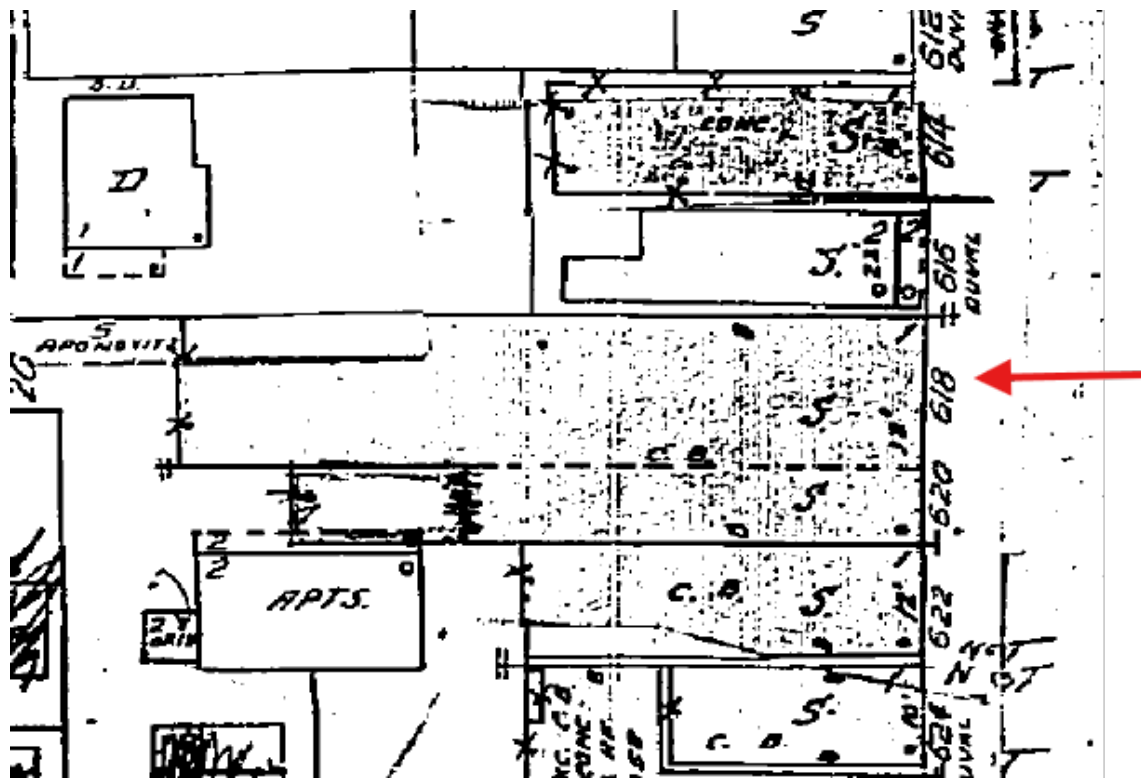

1962 Sanborn Map

PROJECT PHOTOS



Photograph of existing storefront system.



Photograph of 618 Duval and adjacent structure.



Photograph of Duval Street facing to the north.



Photograph of Duval Street facing to the south.



Photograph of 623 Duval structure – Wyland Galleries with folding doors.



Photograph of 619 Duval structure with folding doors.



Photograph of 626 Duval structure with folding doors.

SURVEY

DUVAL STREET

618-620

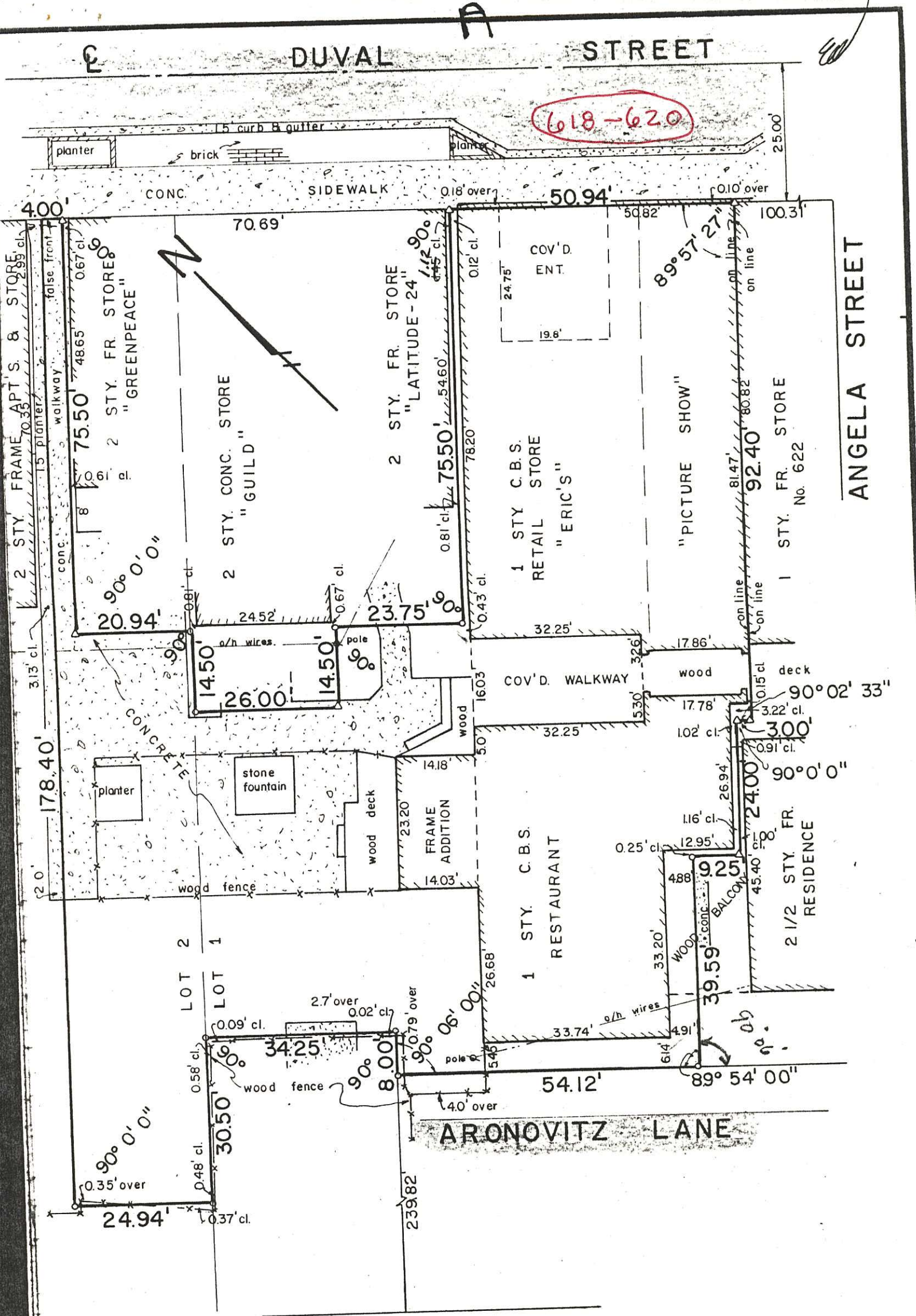

WHITEHEAD STREET

ANGELA STREET

Old Town Key West Development, Ltd.
618-620 Duval Street, Key West, FL 33040

FREDERICK H. HILDEBRANDT, IN
PROFESSIONAL LAND SURVEYOR

SKETCH OF SURVEY

Dwn. No.
84-265-08

414 Simonton St.
Key West, Fla. 33040

P.O. Box 970371
Miami, Fla. 33197

Ref. Flood Zone: C Dwn. By: FHH

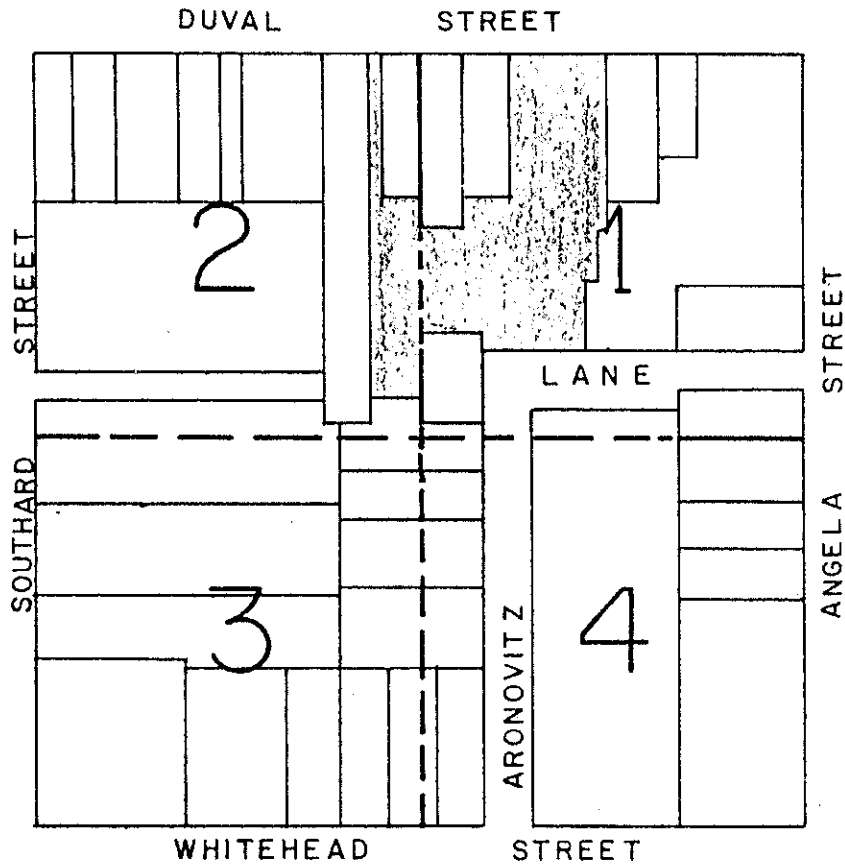
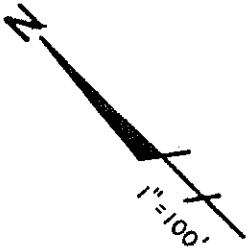

LOCATION MAP

Sq. 62, City of Key West

LEGAL DESCRIPTION:

See Sheet 2 of 2

SURVEYORS NOTES:

North arrow based on an assumed meridian
all angles 90 degrees, unless otherwise noted

- o/h = Overhead
- o = Set P.K. Nail .
- Δ = Set Iron Pipe

CERTIFICATION:

I HEREBY CERTIFY that the attached "SKETCH OF SURVEY" is true and correct to the best of my knowledge and belief; that it meets the minimum technical standards adopted by the Florida Society of Professional Land Surveyors; Florida Statute Section 472.027; and the Florida Land Title Association; and that there are no encroachments unless shown hereon.

Frederick H. Hildebrandt

FREDERICK H. HILDEBRANDT
Professional Land Surveyor No. 2749

LEGAL DESCRIPTION:

On the Island of Key West, and known on William A. Whitehead's Map of the City of Key West as Part of Lots 1 and 2, in Square 62 and being more particularly described as follows:

COMMENCING at the intersection of the Southerly Right-of-Way Line of Duval Street and the Westerly Right-of-Way Line of Angela Street; thence Northwesterly along the said Southerly Right-of-Way Line of Duval Street for 100.31 feet to the Point of Beginning; thence continue along the said Southerly Right-of-Way Line of Duval Street for 50.94 feet; thence at a Right angle and in a Southwesterly direction for 75.50 feet; thence at a Right angle and in a Northwesterly direction for 23.75 feet; thence at a Right angle and in a Southwesterly direction for 14.50 feet; thence at a Right angle and in a Northwesterly direction for 26.00 feet; thence at a Right angle and in a Northeasterly direction for 14.50 feet; thence at a Right angle and in a Northwesterly direction for 20.94 feet; thence at a Right angle and in a Northeasterly direction for 75.50 feet to the said Southerly Right-of-Way line of Duval Street; thence at a Right angle and in a Northwesterly direction along the said Southerly Right-of-Way Line of Duval Street for 4.00 feet; thence at a Right angle and in a Southwesterly for 178.40 feet; thence at a Right angle and in a Southeasterly direction for 24.94 feet; thence at a Right angle and in a Northeasterly direction for 30.50 feet; thence at a Right angle and in a Southeasterly direction for 34.25 feet; thence at a Right angle and in a Southwesterly direction for 8.00 feet to the Northerly Right-of-Way Line of Aronovitz Lane; thence at a angle of 90° 06' 00" to the right and in a Southeasterly direction along the said Northerly Right-of-Way Line of Aronovitz Lane for 54.12 feet; thence at a angle of 89° 54' 00" to the right and in a Northeasterly direction for 39.59 feet; thence at a Right angle and in a Southeasterly direction for 9.25 feet; thence at a Right angle and in a Northeasterly direction for 24.00 feet; thence at a Right angle and in a Southeasterly direction for 3.00 feet; thence at a angle of 90° 02' 33" to the right and in a Northeasterly direction for 92.40 feet to the said Southerly Right-of-Way Line of Duval Street and the Point of Beginning; containing 13,600 Square Feet, more or less.

Old Town Key West Development, Ltd. 618-620 Duval Street, Key West, Fl.		Dwn. No. 84-265-08
LEGAL DESCRIPTION	Ref.	Dwn. By: FHH
Scale: None	Flood Zone:	

FREDERICK H. HILDEBRANDT, INC
PROFESSIONAL LAND SURVEYOR

414 Simonton St. P.O. Box 970378
 Key West, Fla. 33040 Miami, Fla. 33197

PROPOSED DESIGN

SITE DATA

SITE ADDRESS: 618 DUVAL STREET, KEY WEST, FL 33040
 RE: 000125882-000000
 ZONING: HRCC1
 FLOOD ZONE: X
 F.I.R.M.- COMMUNITY#120168; MAP & PANEL #12087C1516K; DATE:02-18-05
 SECTION/TOWNSHIP/RANGE: 06/68/25
 LEGAL DESCRIPTION: KW PT LOTS 1 & 2 SQR 62 G10-140

INDEX OF DRAWINGS

SHEET A-1 - STOREFRONT PLAN

SCOPE OF WORK

- REPLACE AN EXISTING STOREFRONT WITH FOLDING DOORS



SITE LOCATION

2 SITE PHOTOGRAPH
 A-1 SCALE: NTS



SITE LOCATION

1 SITE LOCATION PLAN
 A-1 SCALE: NTS



9'-2"

3 EXISTING ELEVATION
 A-1 SCALE: 3/8" = 1'-0"

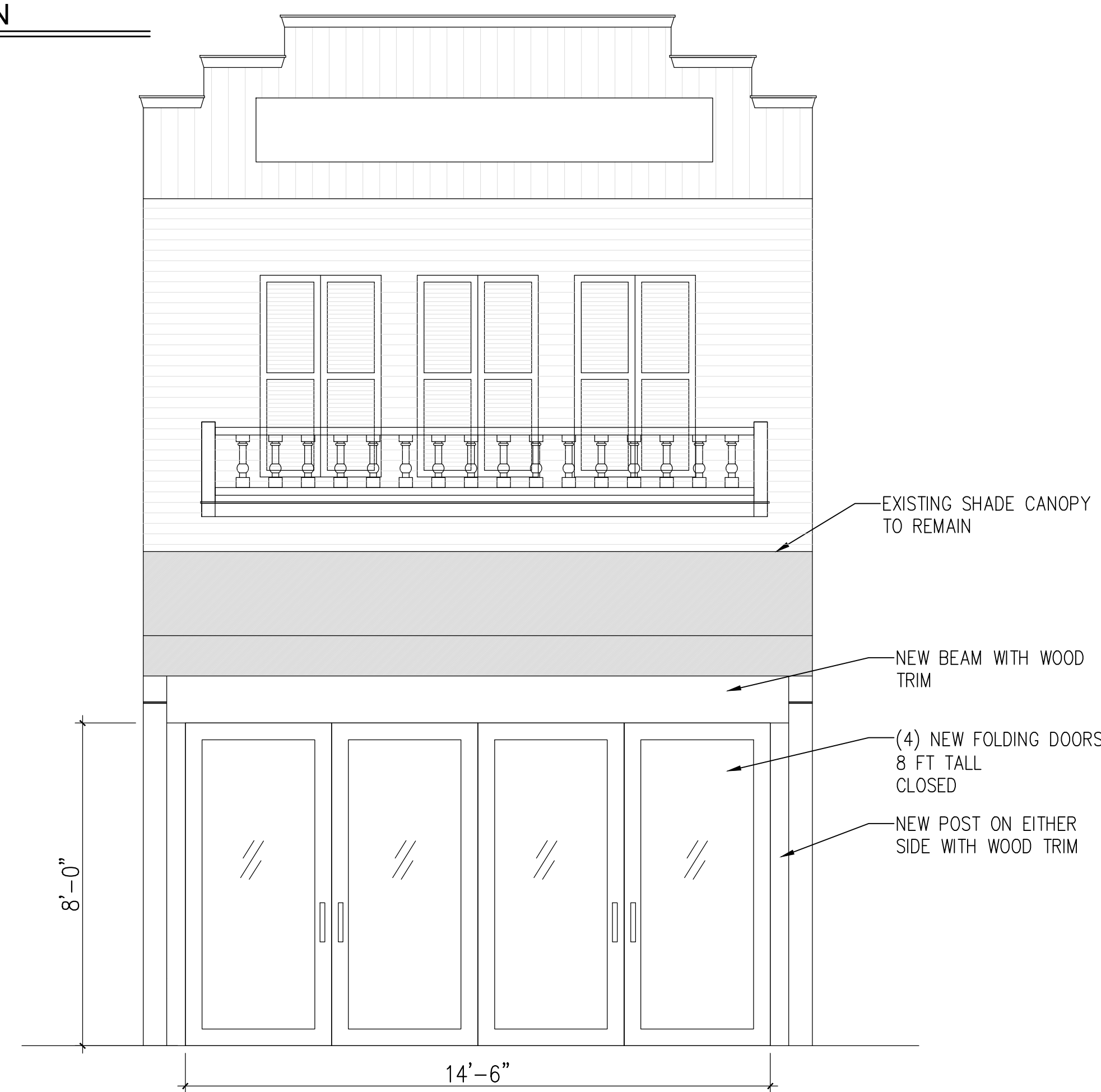

8'-0"

14'-6"

EXISTING SHADE CANOPY TO REMAIN

NEW BEAM WITH WOOD TRIM

(4) NEW FOLDING DOORS 8 FT TALL CLOSED

NEW POST ON EITHER SIDE WITH WOOD TRIM

4 PROPOSED ELEVATION (DOORS CLOSED)
 A-1 SCALE: 3/8" = 1'-0"

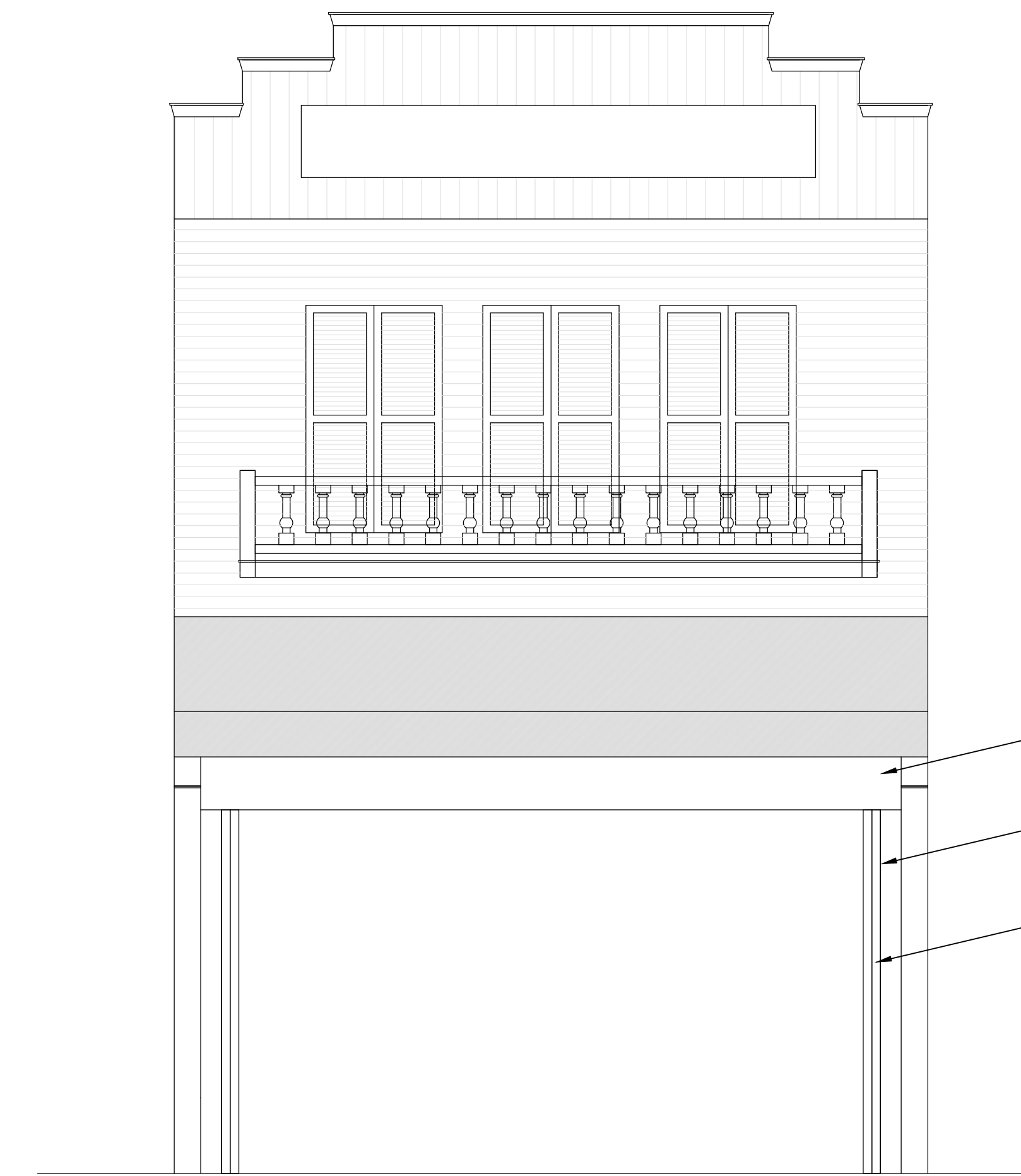

NEW BEAM WITH WOOD TRIM

(4) NEW FOLDING DOORS 8 FT TALL CLOSED

(4) NEW FOLDING DOORS 8 FT TALL FULLY OPEN

5 PROPOSED ELEVATION (DOORS OPEN)
 A-1 SCALE: 3/8" = 1'-0"

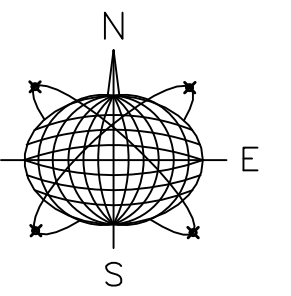

Northstar Engineering LLC
 13 Bamboo Terrace
 Key Haven, Florida 33040
 AUTHORIZATION #34715
 ph:305-481-0400

Seal:

NOT VALID FOR CONSTRUCTION UNLESS SIGNED AND SEALED IN THIS BLOCK
 RICHARD J. MILELLI
 PE #58315

General Notes:

HARC
 SUBMITTAL
 618 DUVAL STREET
 KEY WEST, FLORIDA

Drawn By: RJM	Checked By: RJM
Project No.	Scale: AS NOTED

AutoCad File No.

Revisions:

Title:

STOREFRONT PLAN

Sheet Number:

A-1

Date: MARCH 22, 2026

DUVAL

618 DUVAL

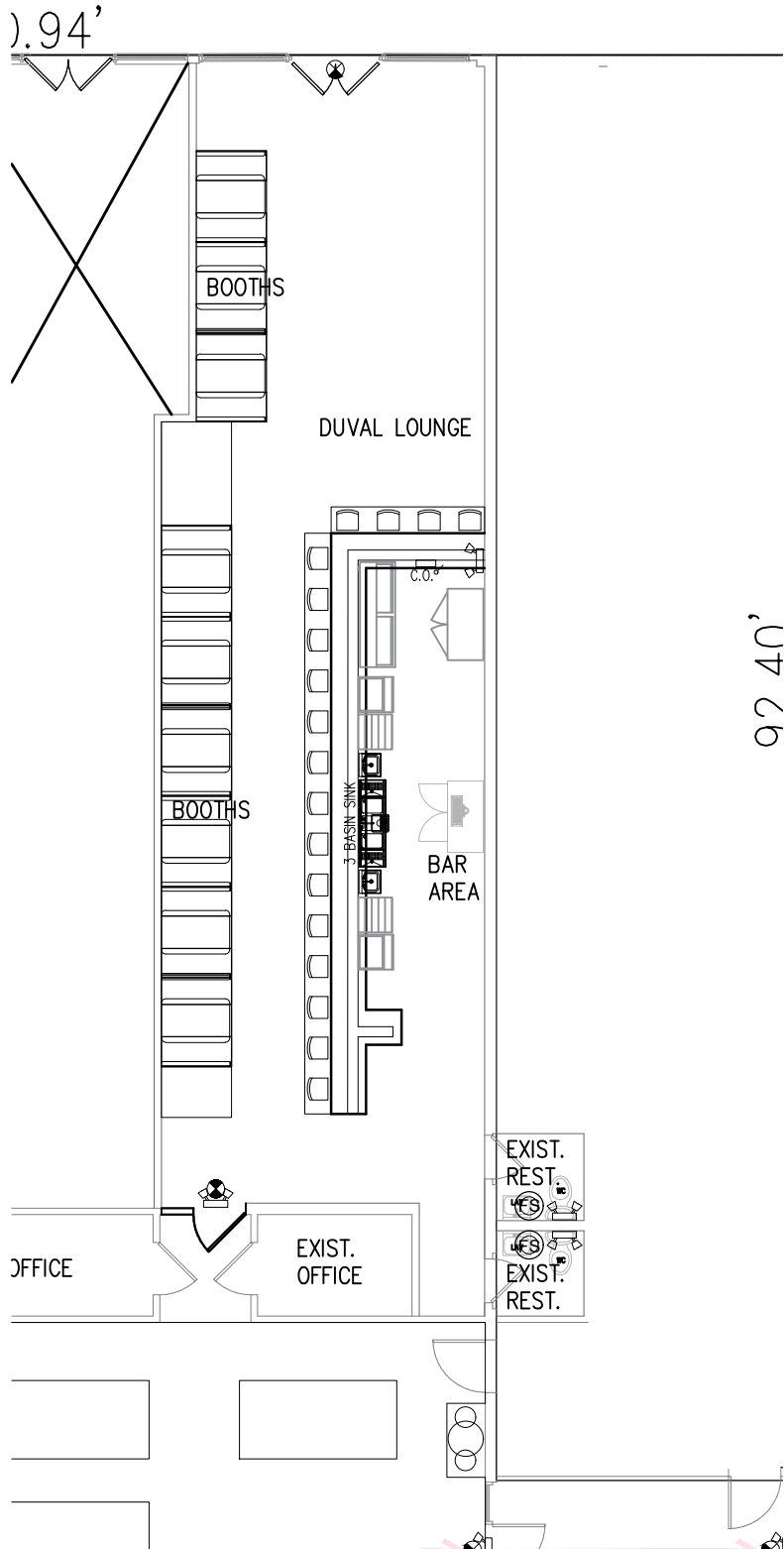

DUVAL

618 DUVAL

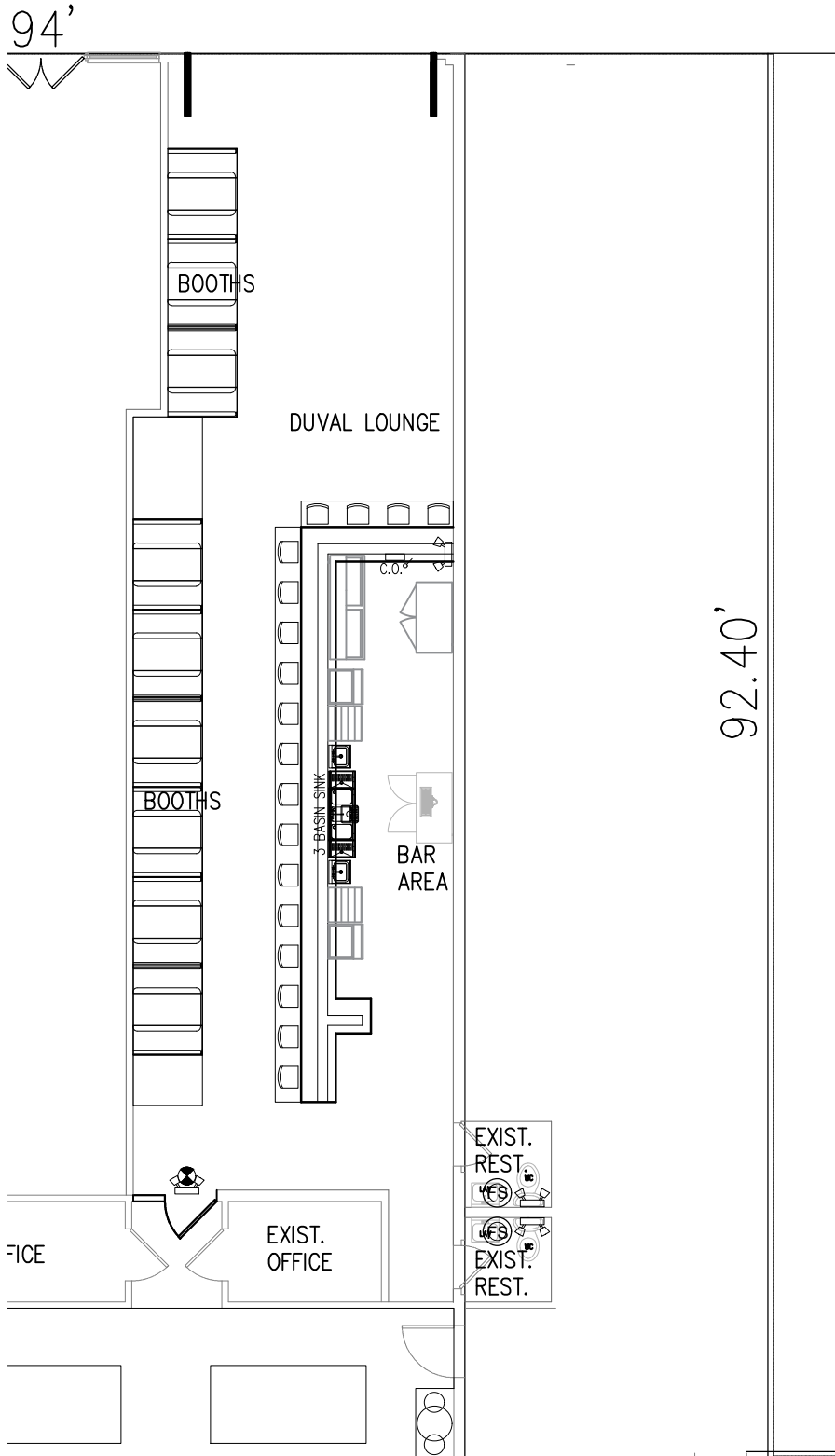

ARCHITECT CUT SHEET

VISTA FOLD™ IMPACT RATED ALUMINUM FOLDING DOORS



The Vista Fold™ impact rated aluminum door system provides unobstructed views and seamless transitions to the outside. Euro-Wall folding doors systems can span heights up to 168", widths up to 52", can be configured as a radius or postless corner systems and can span large opening widths with an unlimited number of sequential panels. Vista Fold™ applications are Florida Product Approved and meet the strict Florida Building Code and has the highest dp rating of any folding door available.

FL 17838



PANEL MINIMUM / MAXIMUM

Max Panel Weight:	350 lbs	Min Panel Height:	32"
Min Panel Width:	18"	Max Panel Height:	168"
Max Panel Width:	52"	Max Sq Ft:	334 sq ft

OVERVIEW DIAGRAM

Interior View

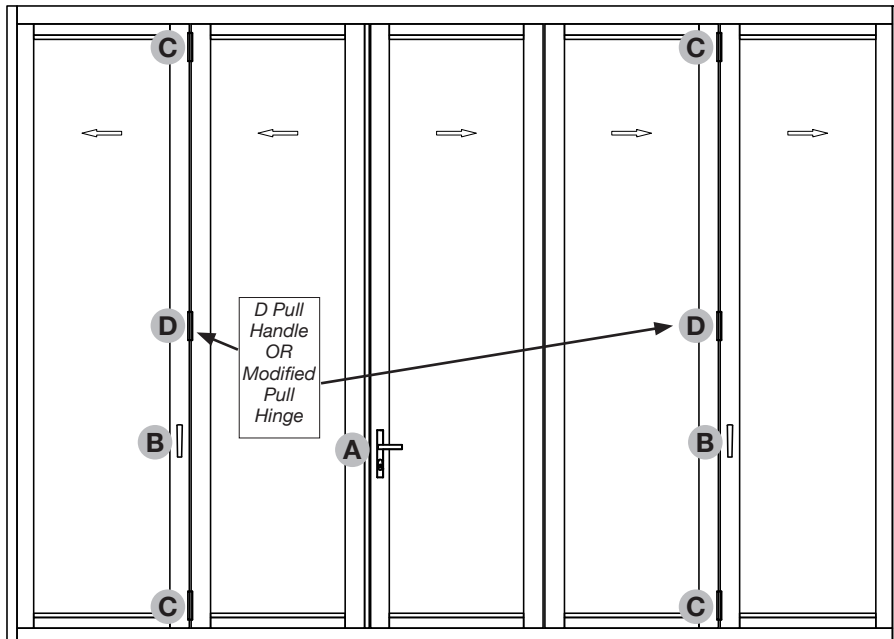

- A** **Multipoint Handle**
LORI: C0064
ROLI: C0096
- B** **Twinpoint Lever**
C0352
- C** **Modified Hinge**
C0106
- D** **D Pull Handle**
C0095
- D** **Modified Pull Hinge**
C0107

Exterior View



- A** **Multipoint Handle**
LORI: C0064
ROLI: C0096
- B** **Upper Jamb Hinge**
LORI: C0069
ROLI: C0070
- C** **Lower Jamb Hinge**
LORI: C0071
ROLI: C0072
- D** **Center Wall Pivot**
LORI: C0104
ROLI: C0105
- E** **Upper Intermediate Carrier**
LORI: C0065
ROLI: C0066
- F** **Lower Intermediate Carrier**
LORI: C0100
ROLI: C0101
- G** **Upper Carrier**
LORI: C0067
ROLI: C0068
- H** **Lower Carrier**
LORI: C0102
ROLI: C0103
- I** **Modified Hinge**
C0106

Note: Both systems pictured are outswing systems; inswing systems would be the opposite.

CONFIGURATIONS

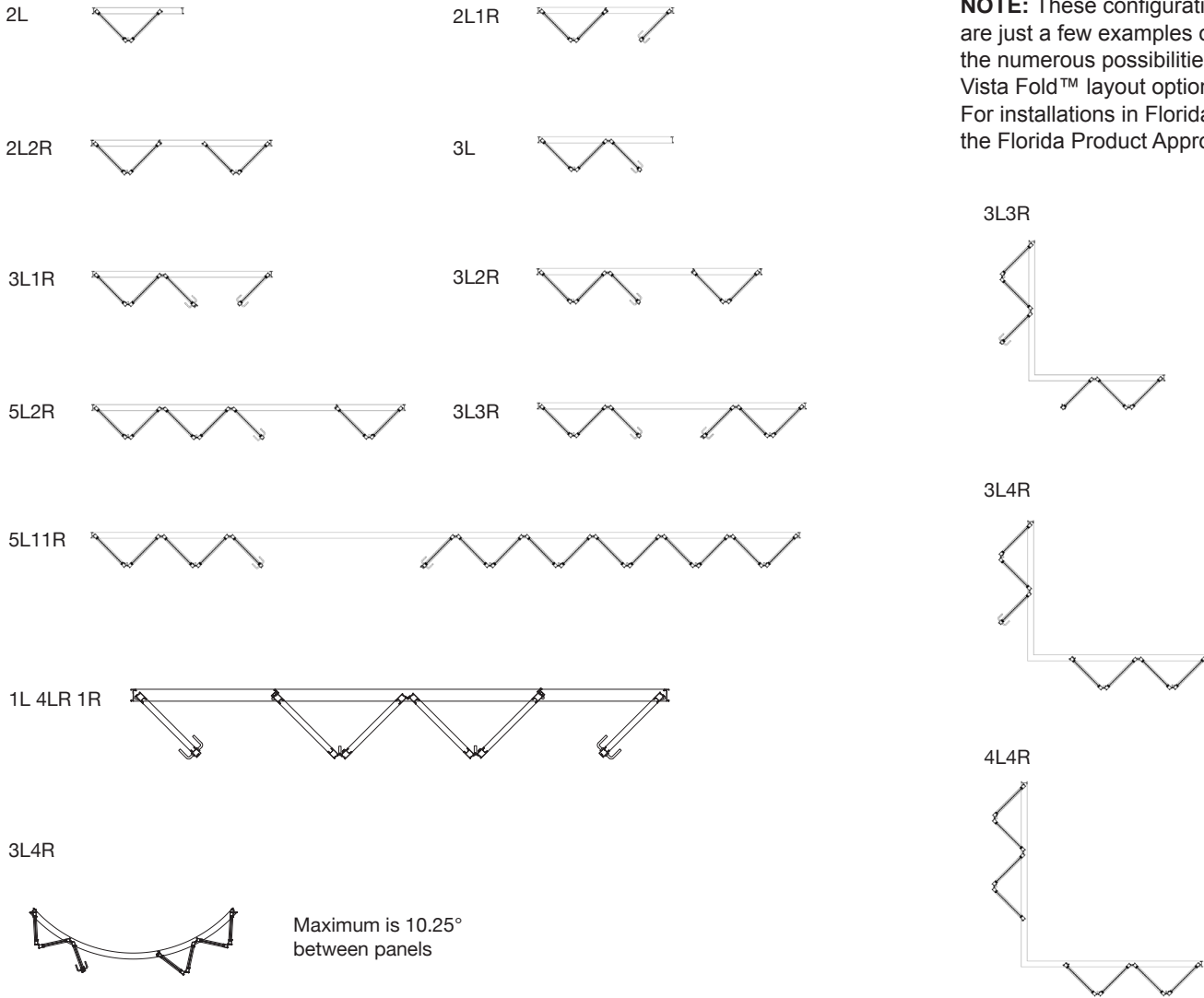

EXTRUSION PROFILES

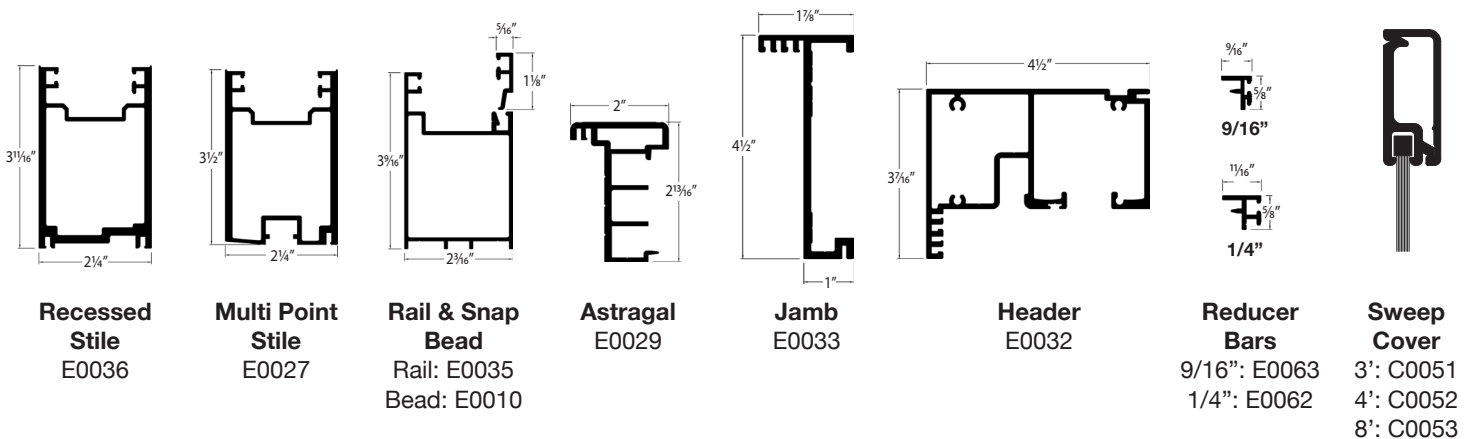

HANDLES

Multi Point 5 Point Locking Handle LORI: C0064 / ROLI: C0096

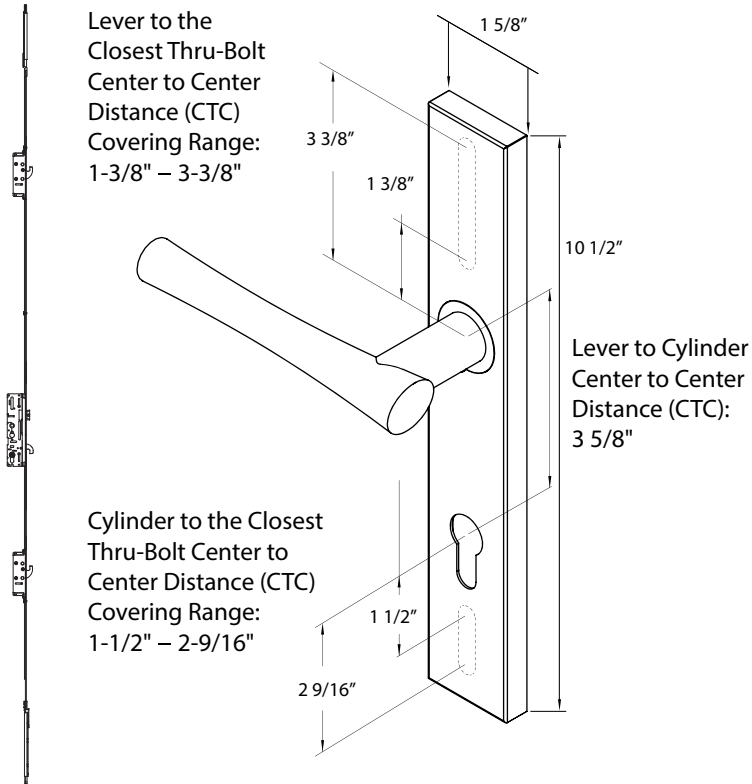

Details of multi point lock continued on pg. 5



PULL HARDWARE

D Pull Handle C0095

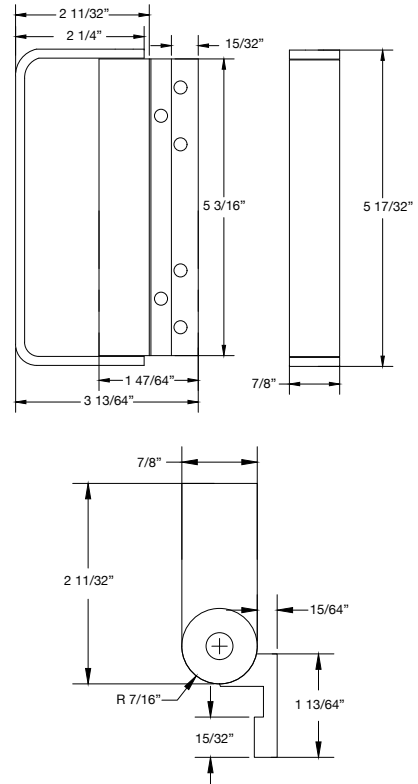

HINGES

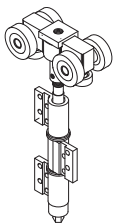

Upper Intermediate Carrier
LORI: C0065
ROLI: C0066

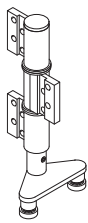

Lower Intermediate Carrier
LORI: C0100
ROLI: C0101

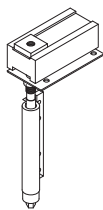

Upper Jamb Hinge
LORI: C0069
ROLI: C0070

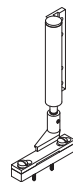

Lower Jamb Hinge
LORI: C0071
ROLI: C0072

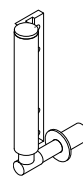

Center Wall Pivot
LORI: C0104
ROLI: C01055

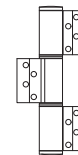

Straight Hinge
C0108

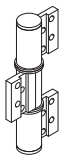

Modified Hinge
C0106

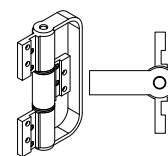

Straight Pull Hinge
C0109

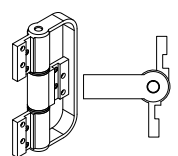

Modified Pull Hinge
C0107



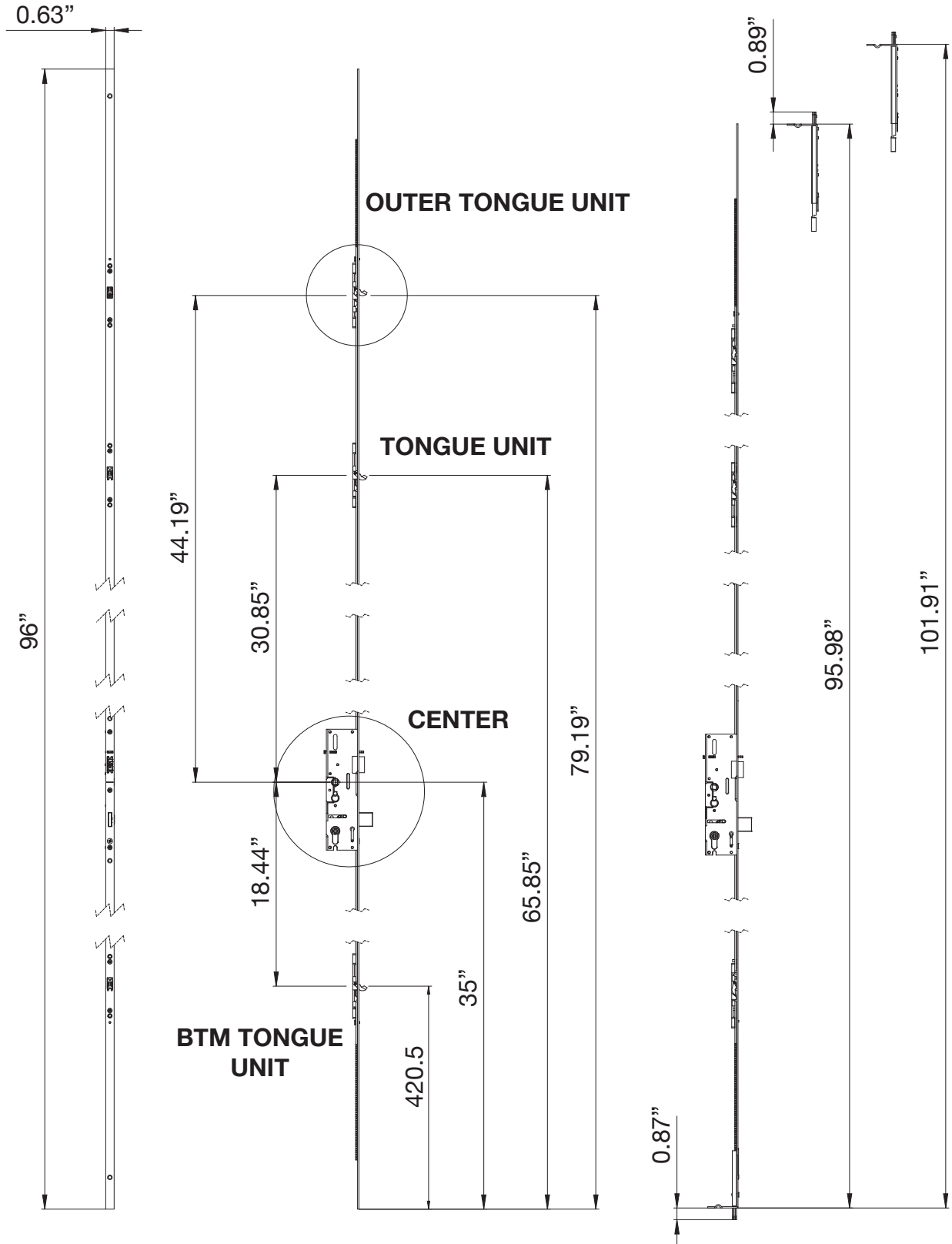

LOCKS

Twinpoint Lever w/ Escutcheon
C0351

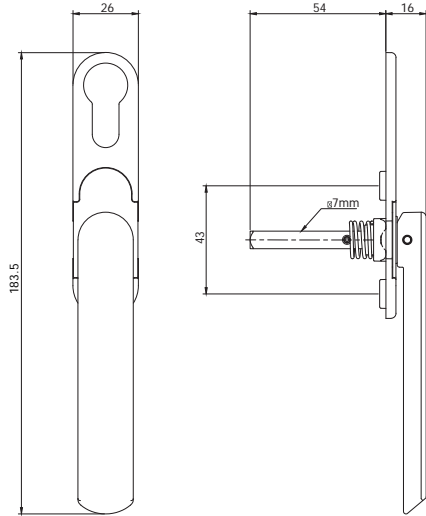

Twinpoint Lever Non-Escutcheon
C0352

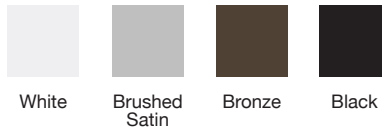
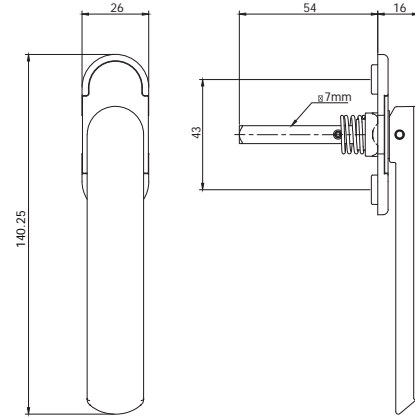

Thumb Turn Locks



50mm Single Sided • Twinpoint Lever
Euro Cylinder Key
Use: Exterior Locking Only, Corner Units Only



70mm Double Sided • Twinpoint Lever
Euro Cylinder Key / Key
Use: Standard Option



90mm Double Sided • Multi Point Handle
Euro Cylinder Key / Thumb Turn
Use: Standard Option
Finish: Satin Nickel, Bronze, Polished, Black



SILLS

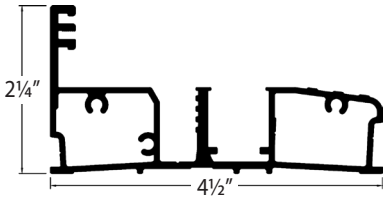

Standard Sill
E0037

HVHZ Impact Rated
Water Rated

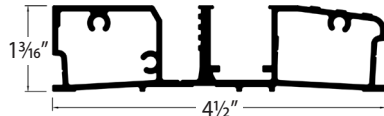

Modified Standard Sill
E0034

HVHZ Impact Rated



ADA Sill
E0028

HVHZ Impact Rated

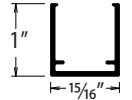

Channel Sill
E0108

Non-FPA

EMBED OPTIONS

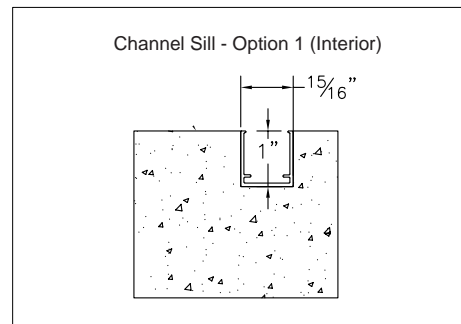
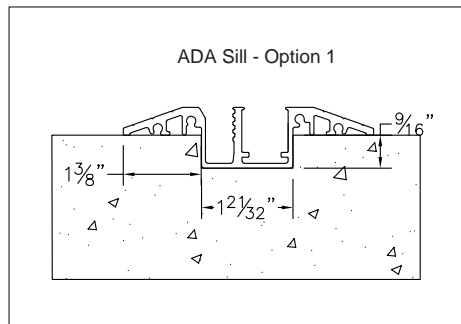
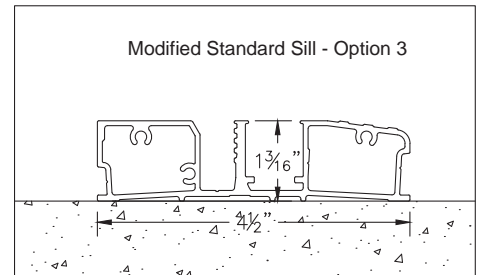
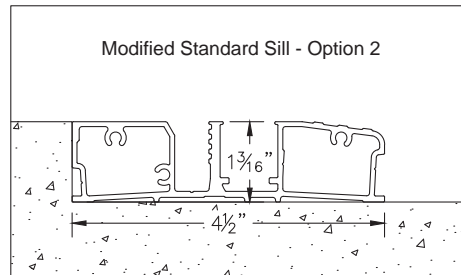
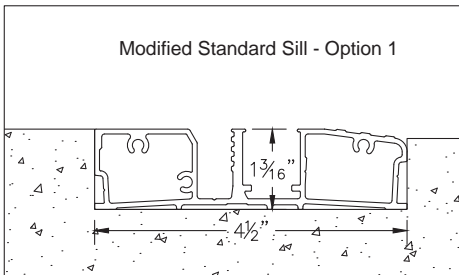
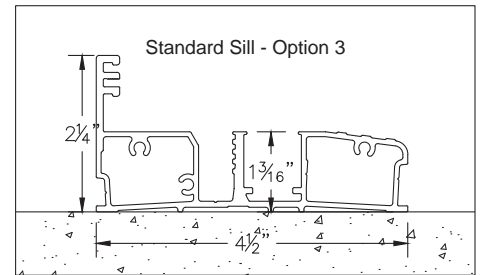
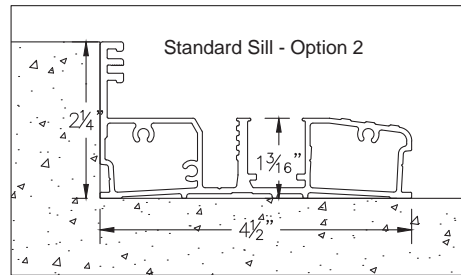
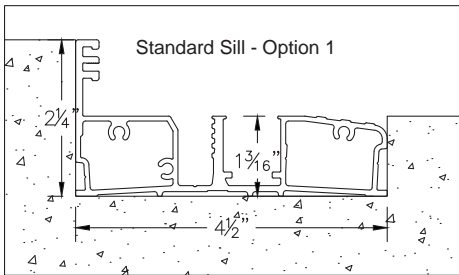

WATER MANAGEMENT

Typical Drain Hole Embedding

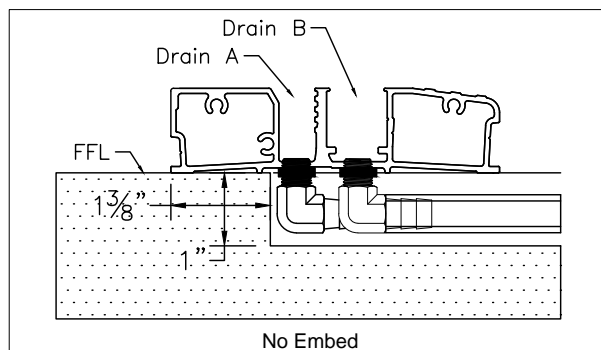
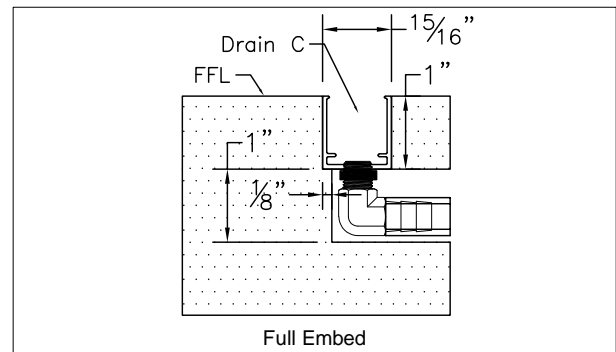
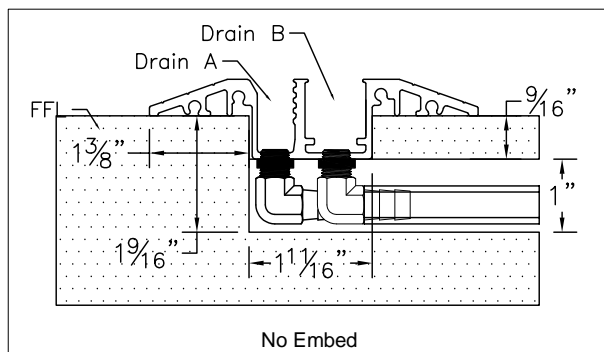
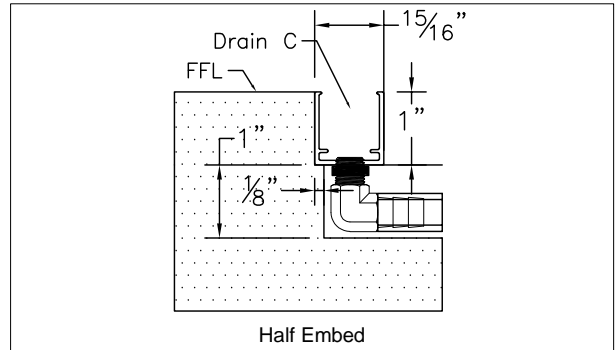
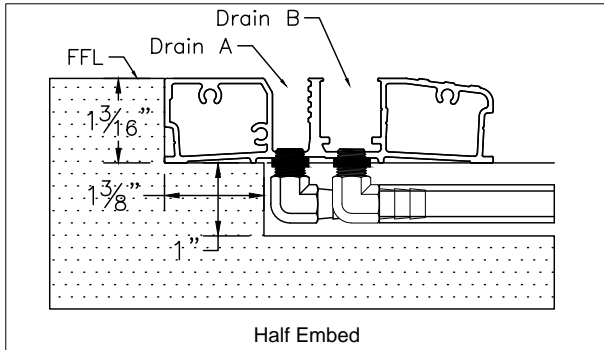
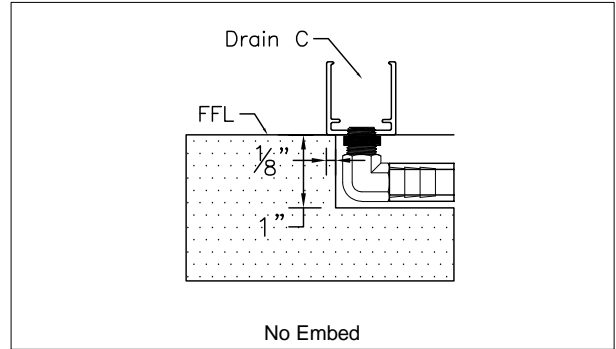
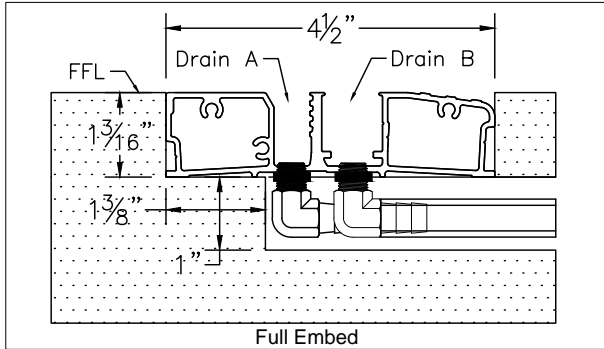

Typical Drain Hole Location

Drill using a 5/16" Bit, and Tap using a 1/8" NPT, with 27 Threads per Inch

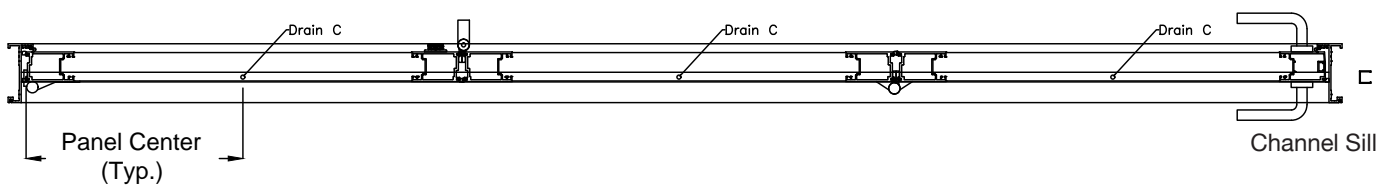
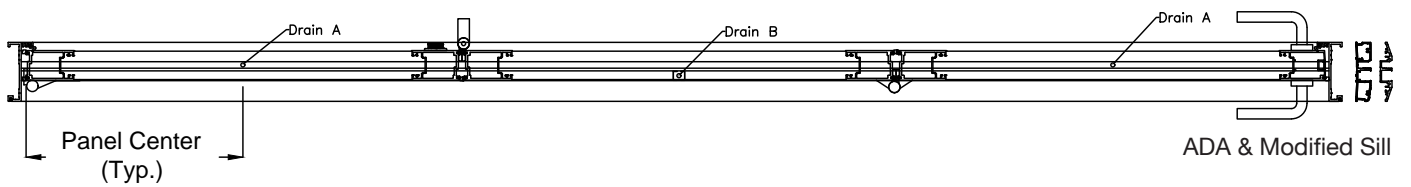
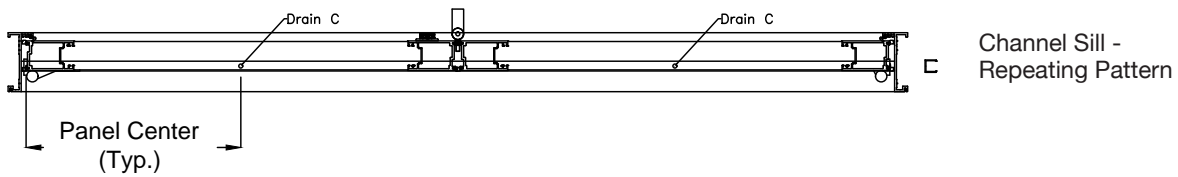
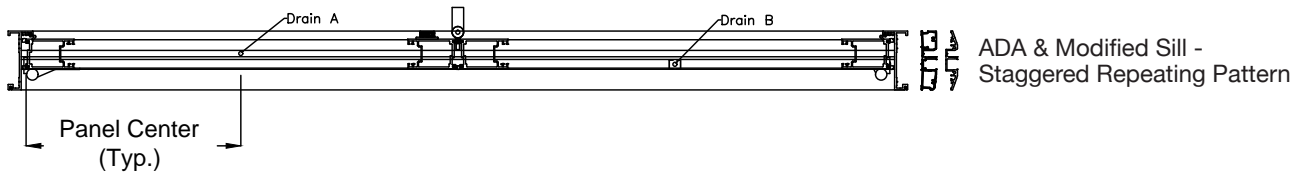
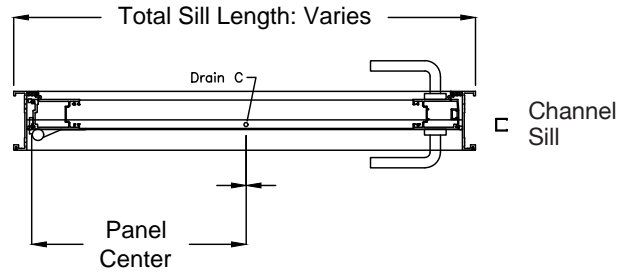
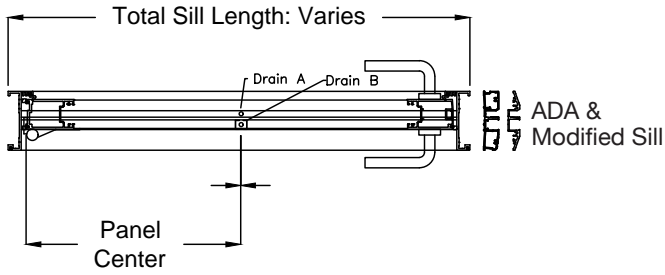

Water Management System Parts

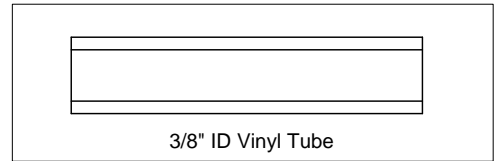
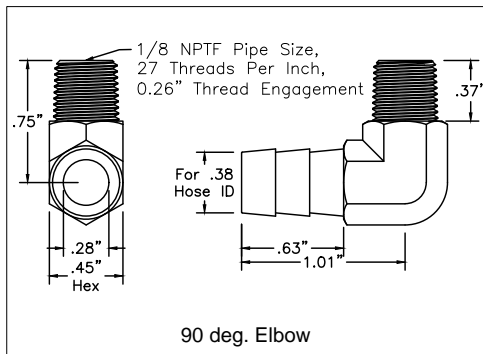
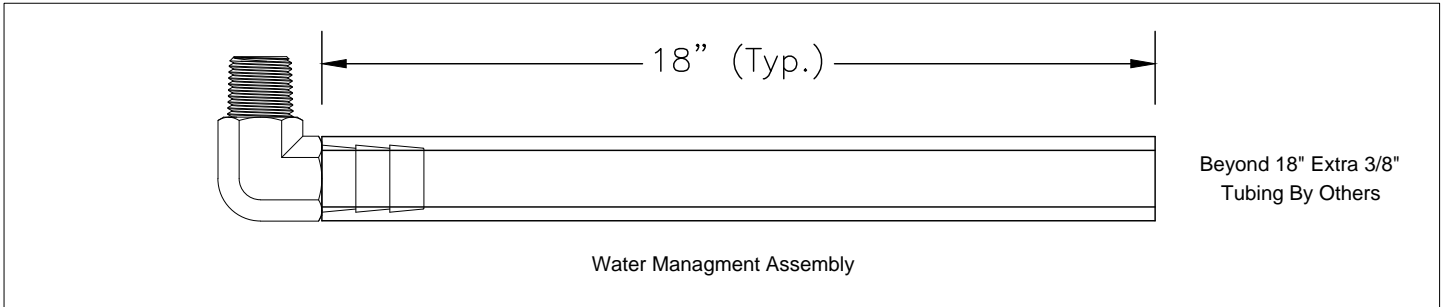

Typical Drain Hole Location

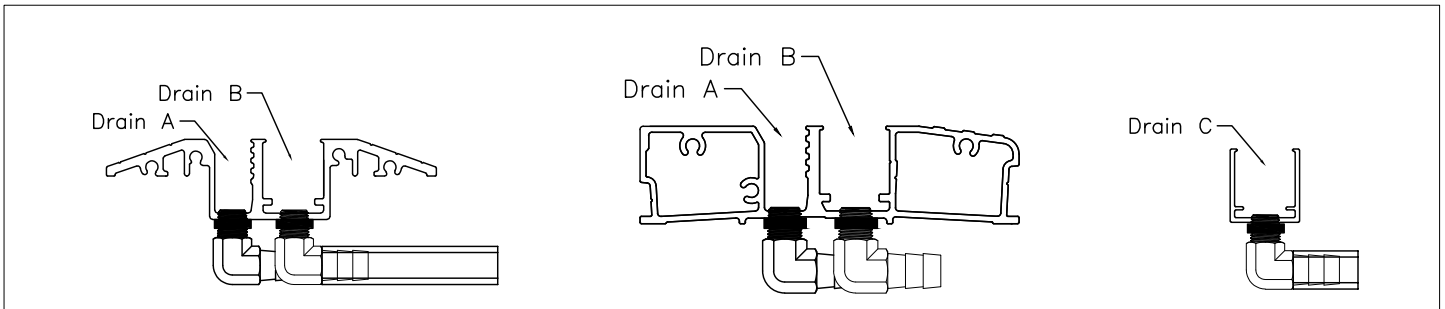

GLAZING DETAILS

Impact Glass (9/16" Monolithic)

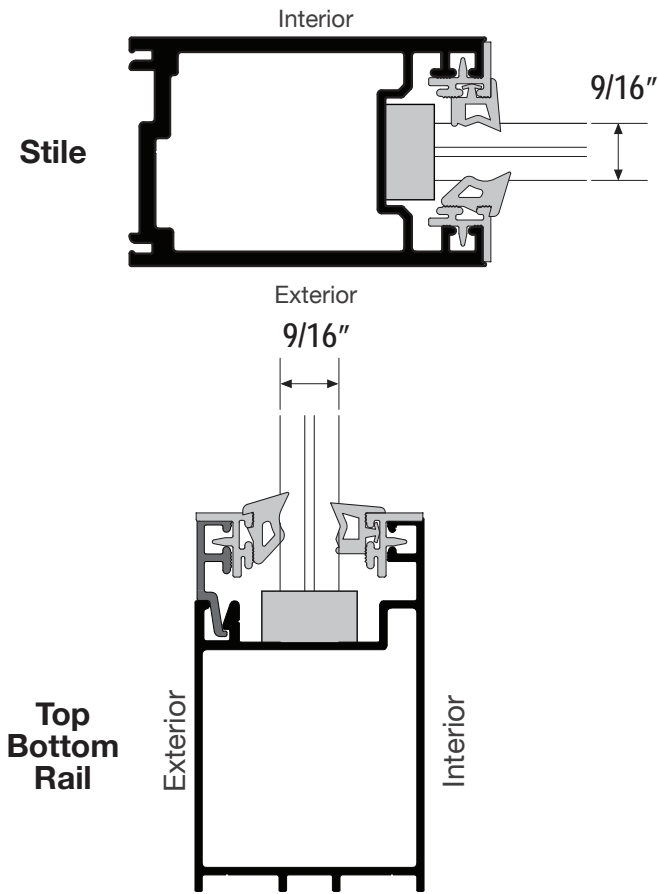

IG Impact

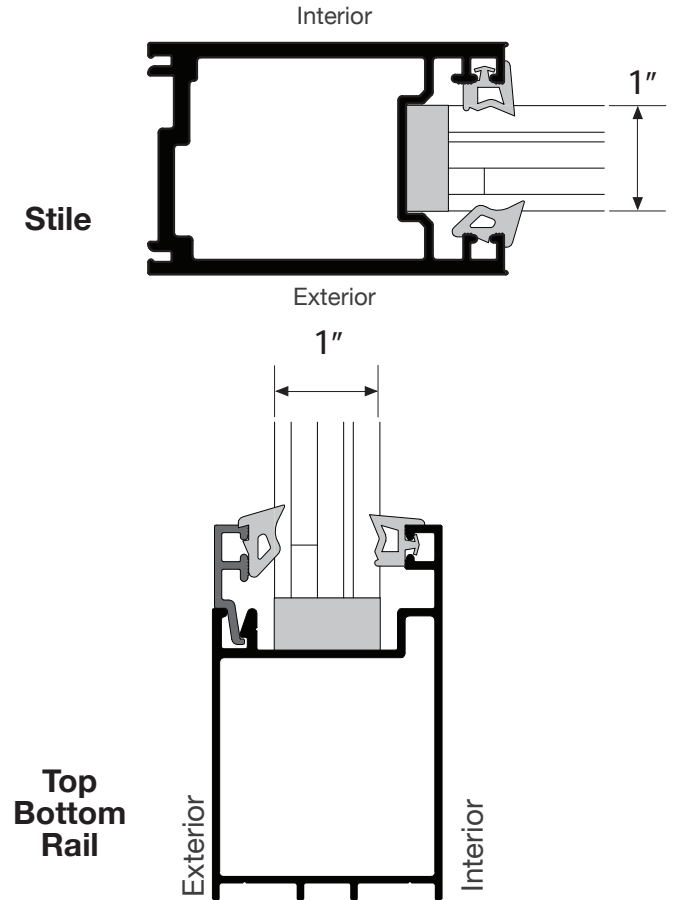

Impact

- 1" Insulated Impact
- 9/16" Mono Impact

Non-Impact

- 1/4" Tempered
- 1/2" Tempered
- 1" Insulated
- 3/8" Tempered
- 1/2" Laminated

FINISH OPTIONS

Standard Finishes

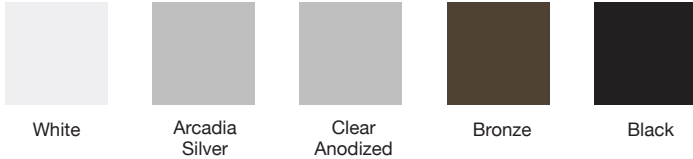

Standard Wood Finishes



Exotic Wood Finishes



Faux Wood Grain Finishes

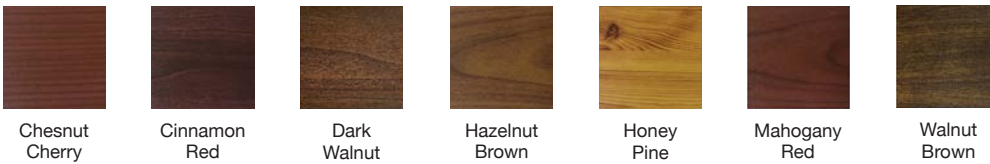

NOTE: All Interior wood clad veneer products should be properly finished or sealed within 36 hours of delivery or stored in a climate controlled space until it can be properly finished or sealed.

GRID OPTIONS

These muntin configurations are just a few examples of the numerous possibilities. All configurations are available in aluminum or wood.

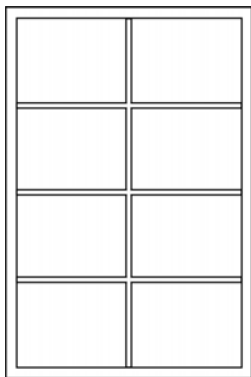

Traditional Grid

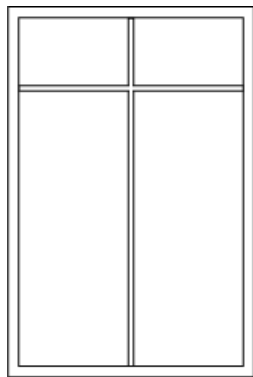

Cross Grid

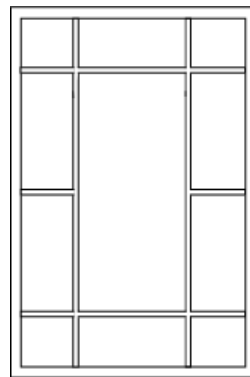

English Grid

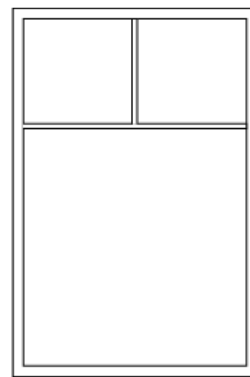

Ladder

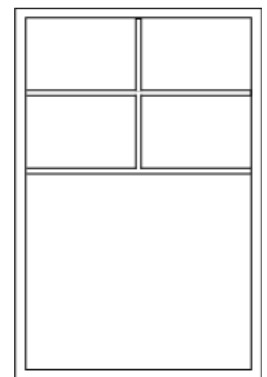

Double Ladder

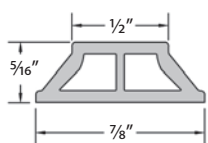

**7/8" OGEE MUNTIN
E0072**

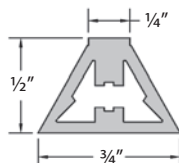

**3/4" RAISED MUNTIN
E0070**



**3/4" FLAT MUNTIN
E0068**

NOTE: The 3/4" flat muntin is primarily used for sliding doors, however if your project has folding and sliding doors this muntin will be used to make them all match.

NOTE: Additional muntin, kickplate, and midrail options available upon request.

ADA - PANIC BARS

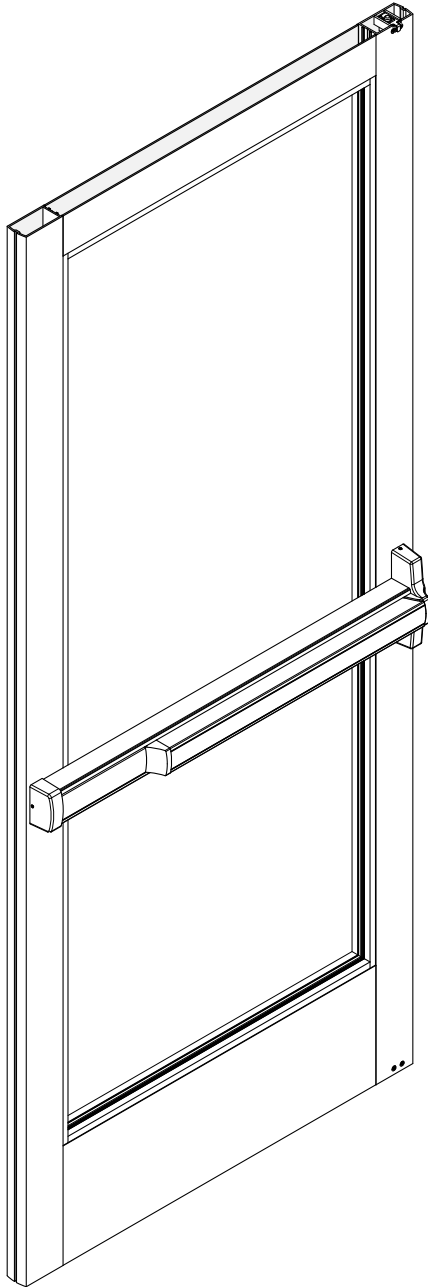

Interior Access

Two Component / Astragal Condition

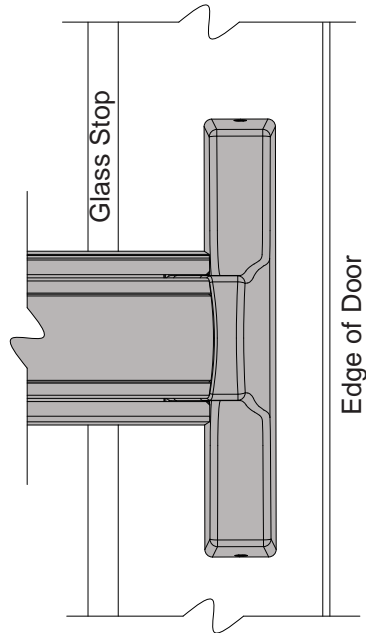

Single Component Non-Impact
By Request Only

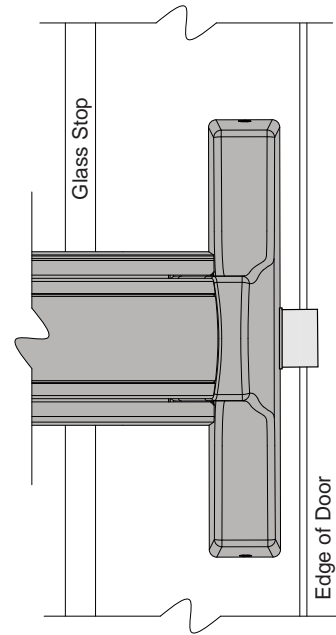

Exterior Access

Note: Optional to have no exterior access.

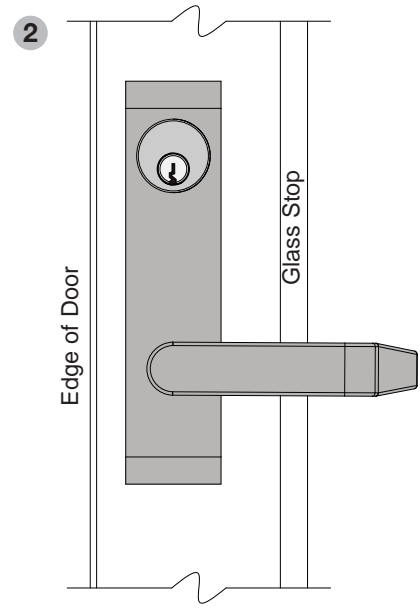
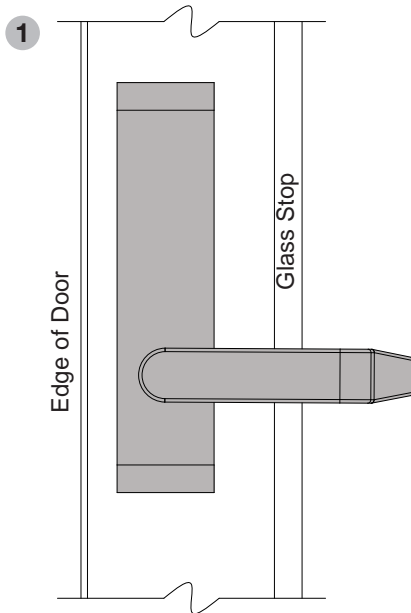

ELEVATION DETAILS - INSWING

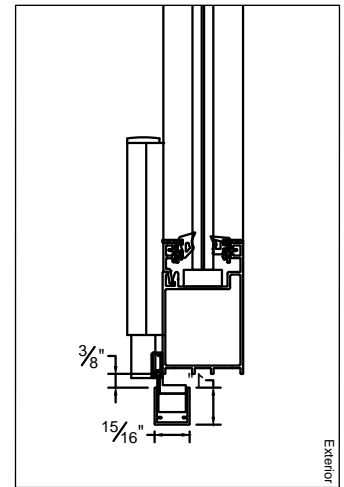
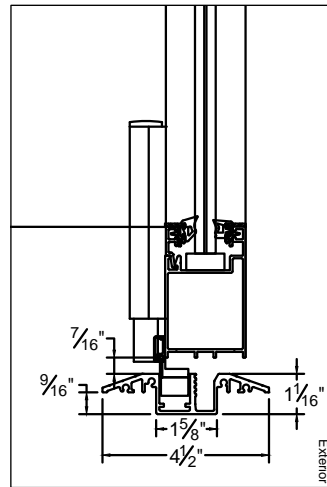
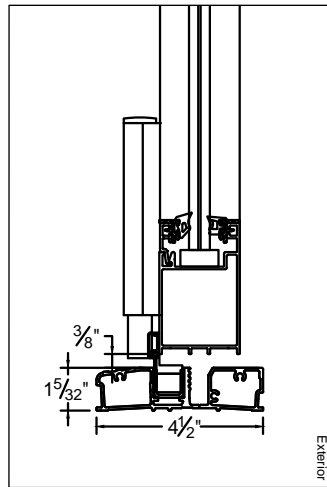
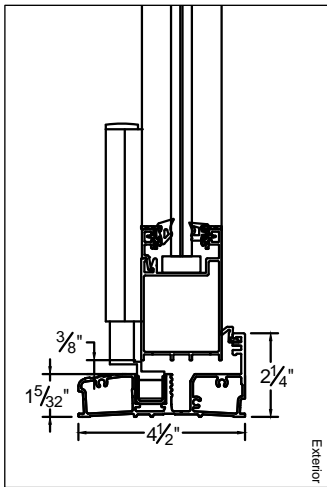
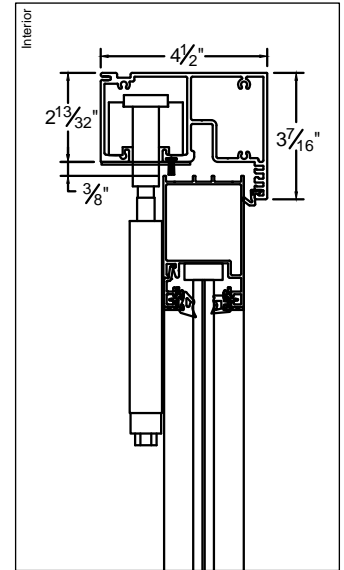
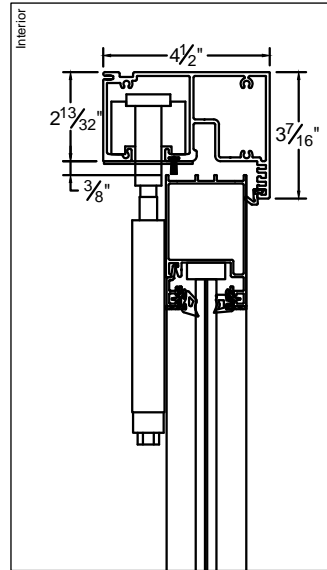
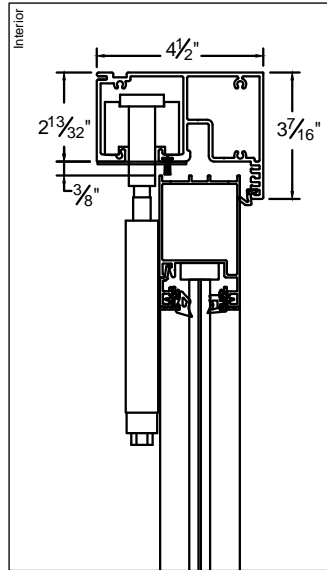
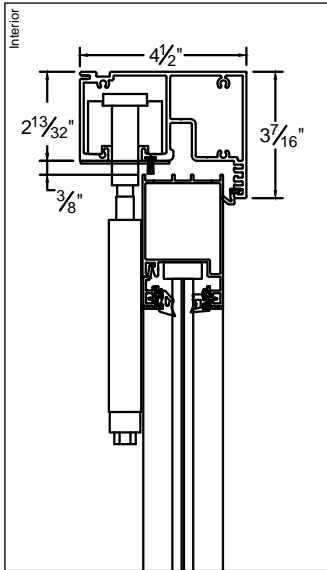

Standard Sill

Modified Sill

ADA Sill

Channel Sill

ELEVATION DETAILS - OUTSWING

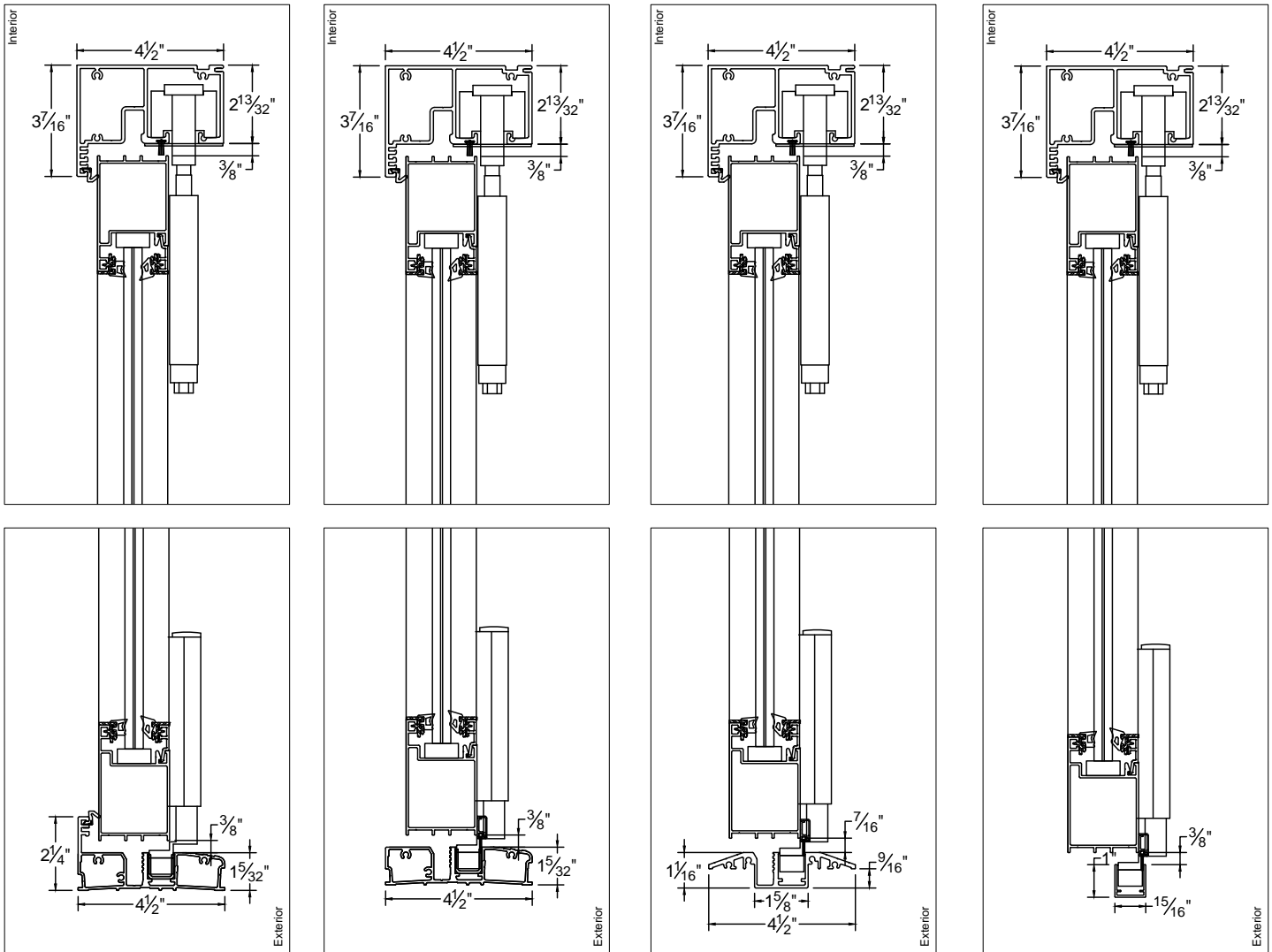

ANCHOR DETAILS

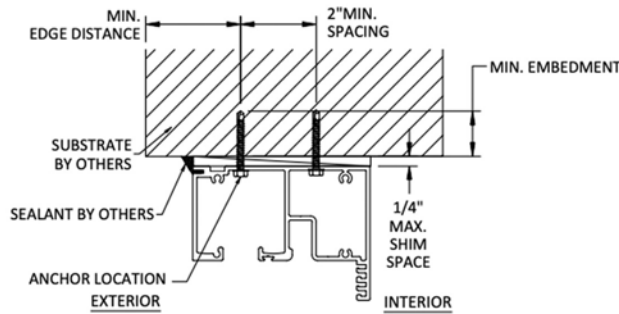

A
6 **ANCHOR DETAIL**
HEAD - THROUGH FRAME

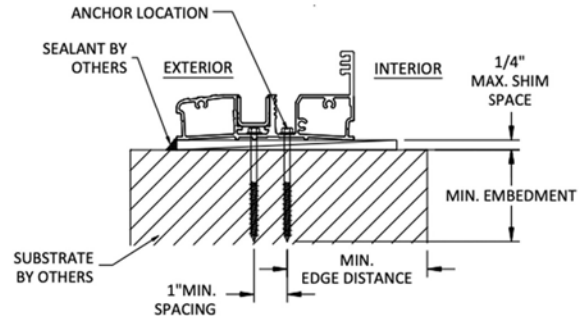

B
6 **ANCHOR DETAIL**
STANDARD SILL - THROUGH FRAME
INSWING/OUTSWING

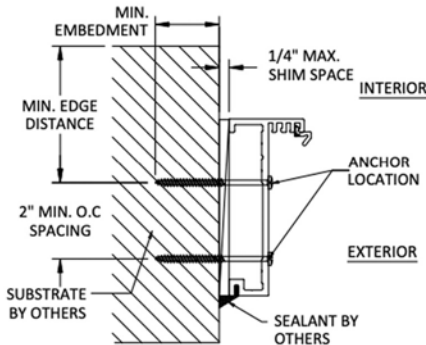

C
6 **ANCHOR DETAIL**
JAMBS - THROUGH FRAME

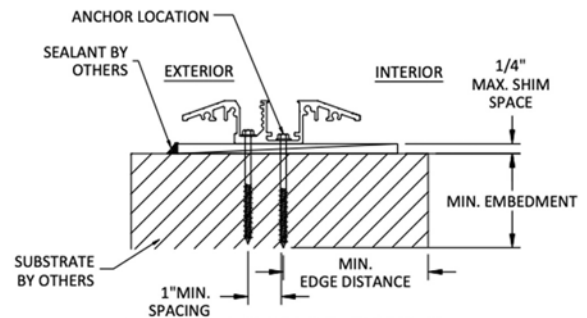

D
6 **ANCHOR DETAIL**
ADA SILL - THROUGH FRAME

ANCHOR SCHEDULE					
INSTALLATION TYPE	QTY PER LOCATION	SUBSTRATE	ANCHOR TYPE	EMBEDMENT (IN.)	EDGE DISTANCE (IN.)
THRU FRAME	2	WOOD (MIN. S.G. = 0.55)	#14 WOOD SCREW	1.5000	0.7500
	2	CONCRETE (MIN. F'C = 2,000 psi) OR CMU (PER ASTM C90)	1/4" ITW TAPCON	1.7500	2.5000
	2	METAL STUD (STEEL MIN. 18GA, Fy = 33ksi) ALUMINUM MIN 1/8", 6063-T5)	1/4" SMS OR SELF DRILLING SCREW	3 THREADS PENETRATION BEYOND METAL WALL	0.5000

- Two installation anchors required at each location shown.
- Option 1x and 2x wood studs for concrete/CMU installation.
- The number of installation anchors depicted is the minimum number of anchors to be used for the product installation of the maximum size listed.
- Install individual installation anchors within a tolerance of $\pm 1/2$ inch the depicted location and spacing in the anchor layout details (I.E. without consideration of tolerances). Tolerances are not cumulative from one installation anchor to the next.
- Shim as required at each installation anchor with load bearing shim(s). Maximum allowable shim stack to be 3/8 inch. Shim where space of 1/16 inch or greater occurs. Shim(s) shall be constructed of high density plastic or better.

- Minimum embedment and edge distance exclude wall finishes, including but not limited to stucco, foam, brick veneer and siding.
- Installation anchors and associated hardware must be made of corrosion resistance material or have a corrosion resistant coating.
- For hollow block and grout filled block, do not install installation anchors into mortar joints. Edge distance is measured from free edge of block or edge of mortar joint into face shell of block.
- Installation anchors shall be installed in accordance with anchor manufacturer's installation instructions, and anchors shall not be used in substrates with strength less than the minimum strength specified by the anchor manufacturer.

1 Left 3 Right Outswing Configuration Shown

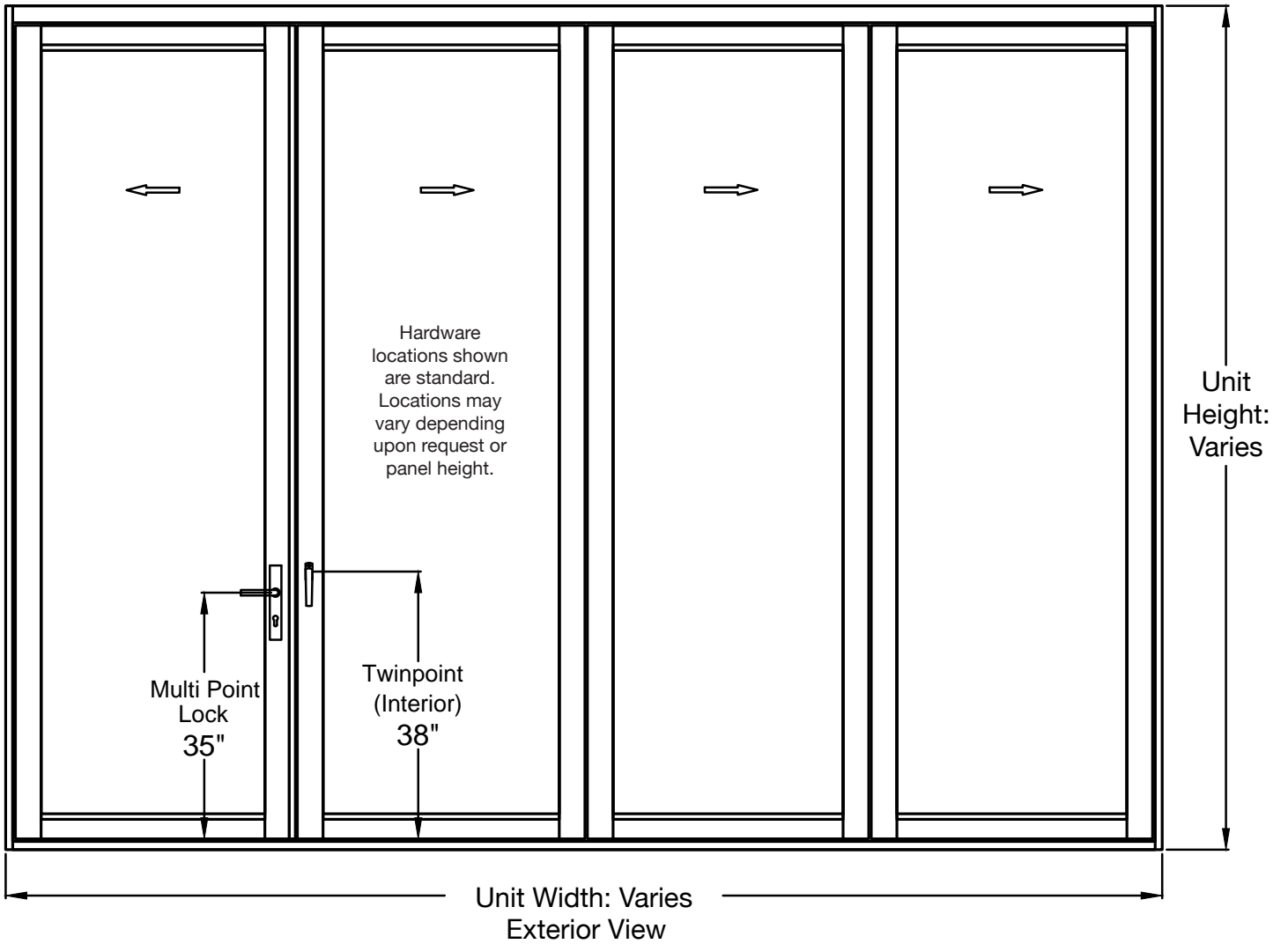

EXTERIOR ELEVATION



HORIZONTAL CROSS SECTION

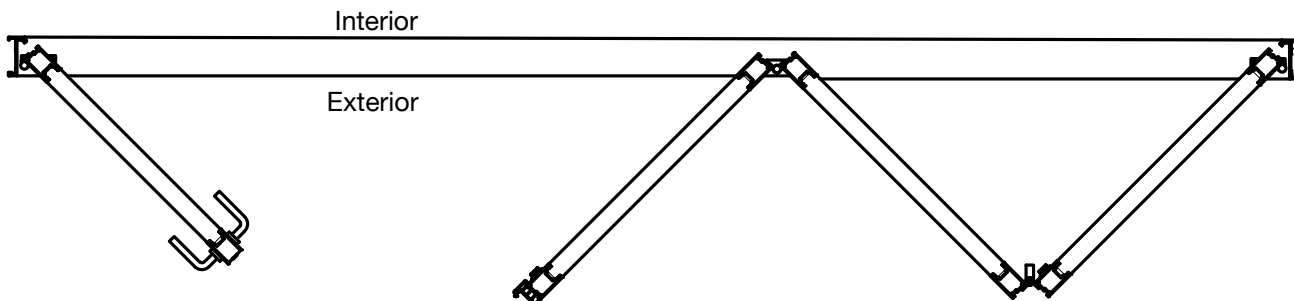

2 Left 2 Right Inswing Configuration Shown

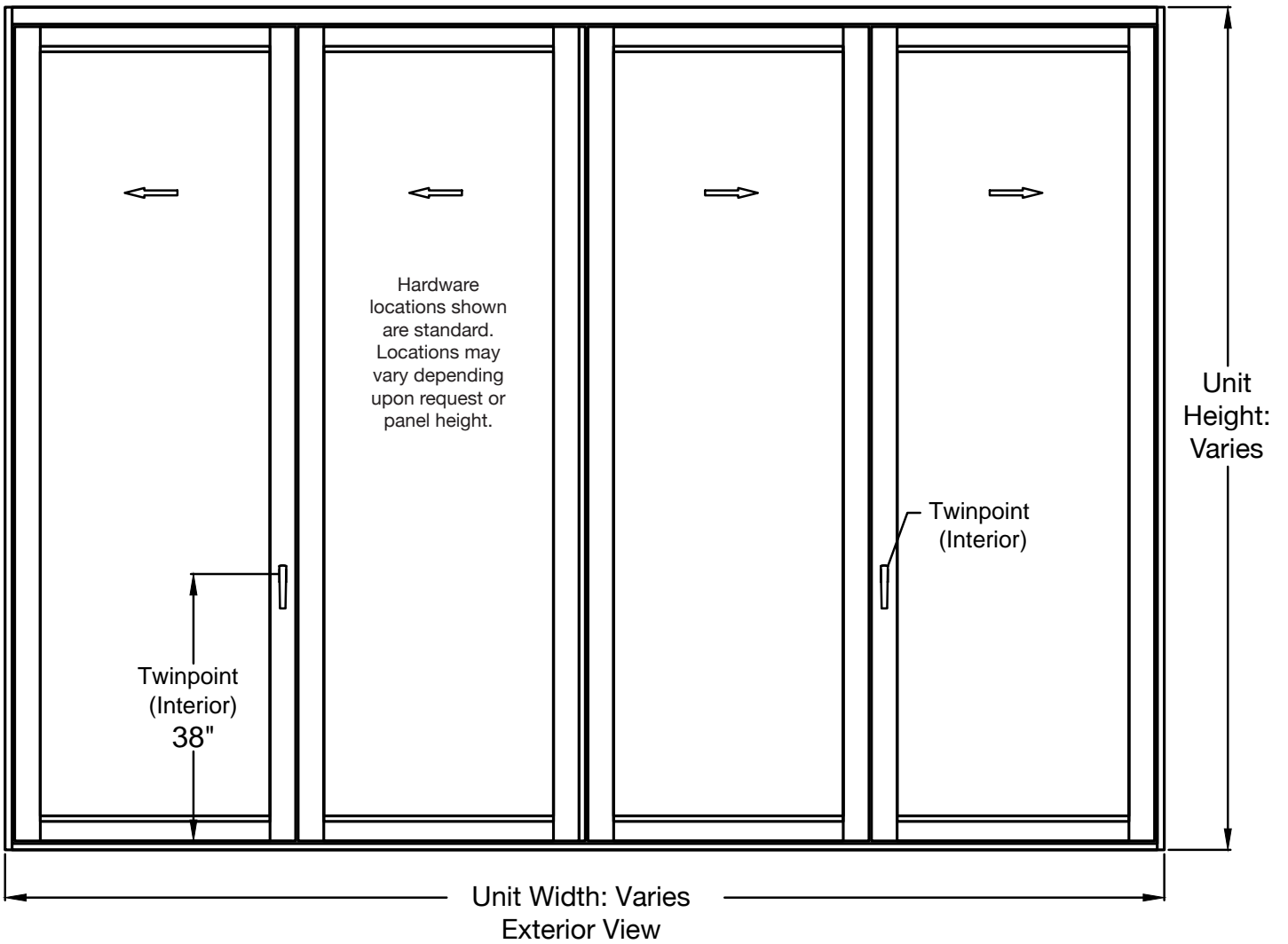

EXTERIOR ELEVATION

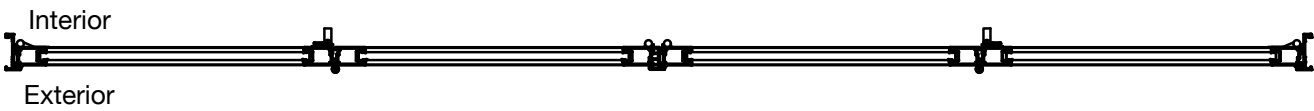

HORIZONTAL CROSS SECTION

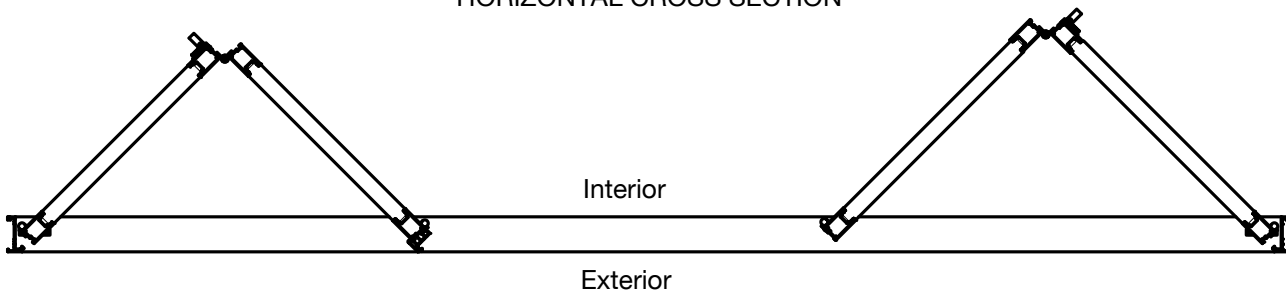

1 Left 3 Right Split Configuration Shown

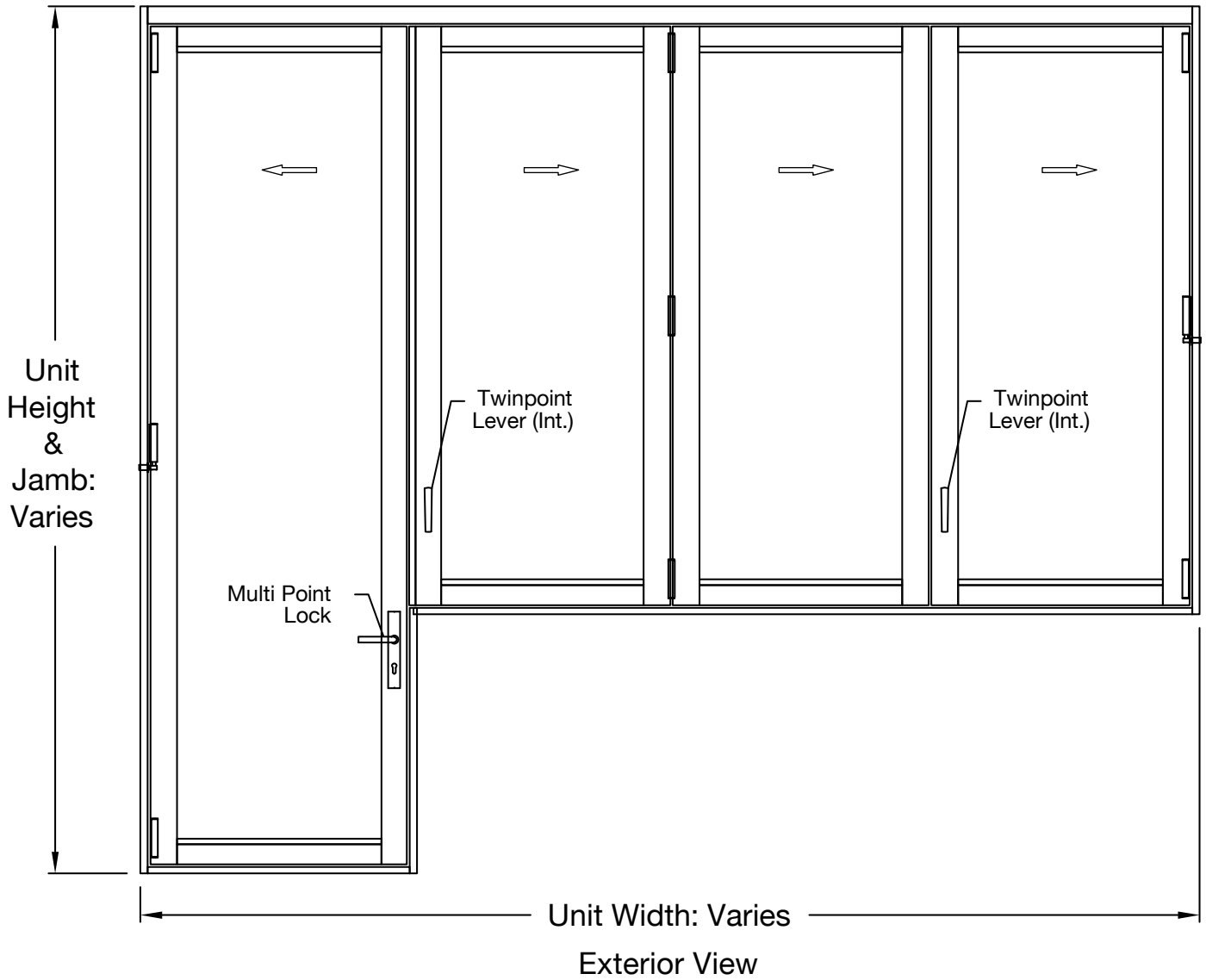

EXTERIOR ELEVATION



HORIZONTAL CROSS SECTION

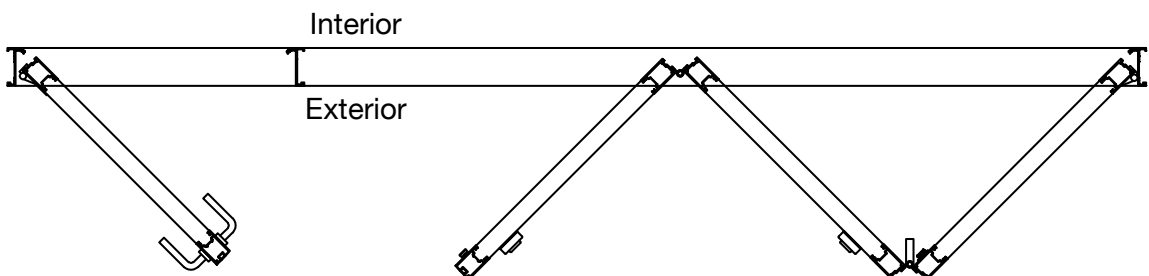

2 Left 2 Right Outswing Bar Top Configuration Shown

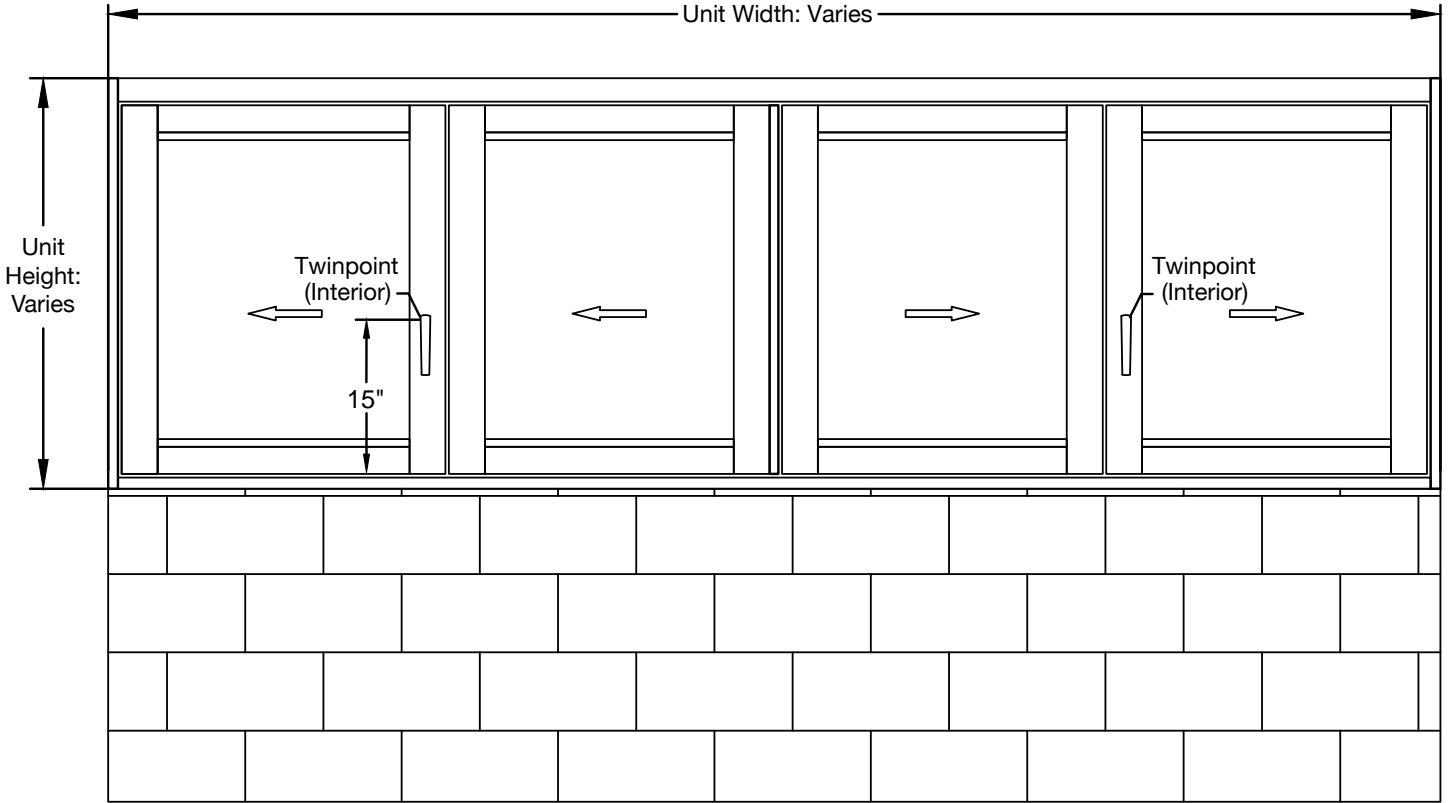

Exterior View

EXTERIOR ELEVATION

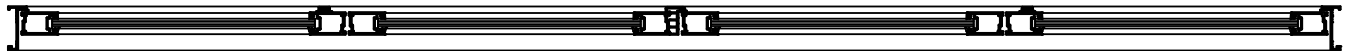

HORIZONTAL CROSS SECTION

Interior View

Exterior View

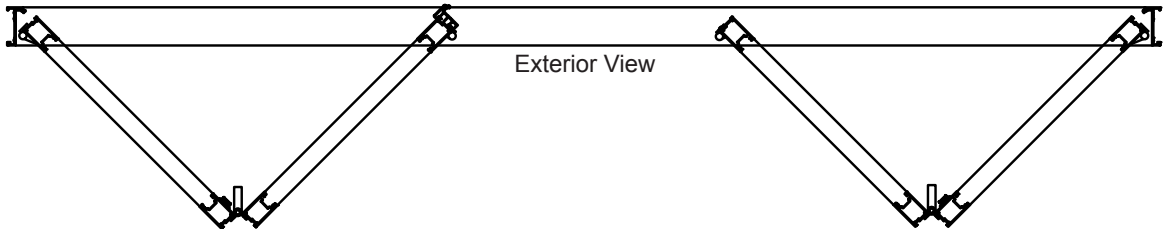

1 Left 4 Left/Right 1 Right Multidirectional Configuration Shown

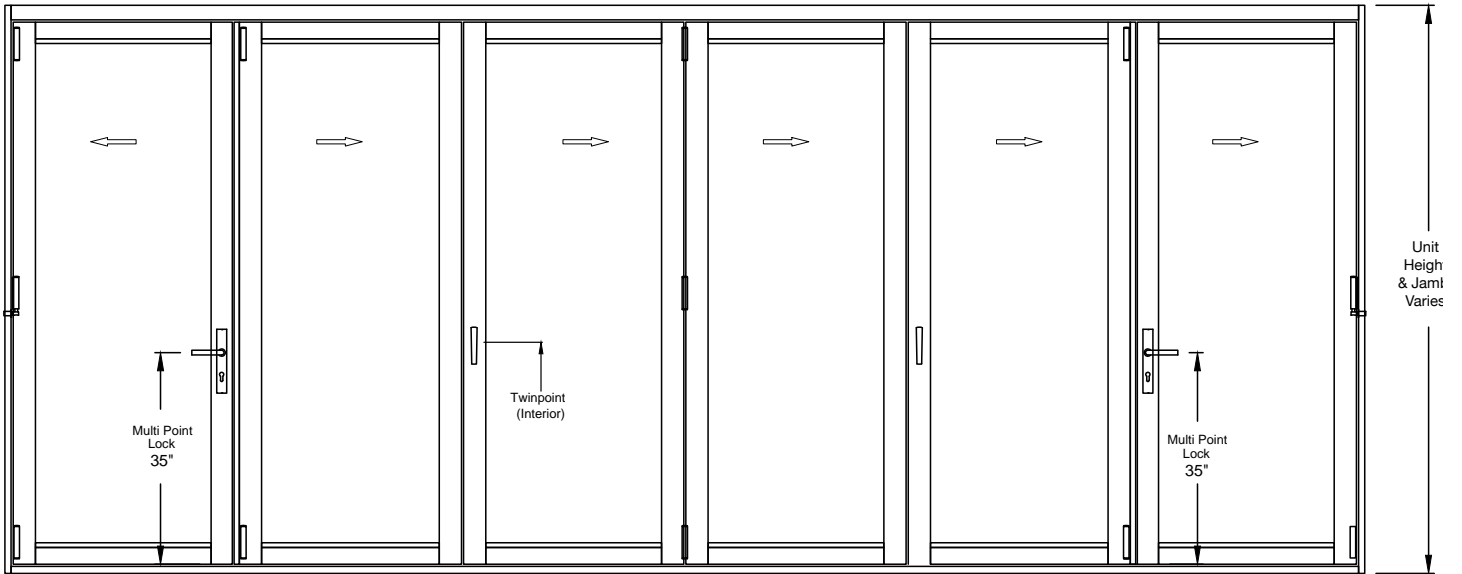

Exterior View

EXTERIOR ELEVATION



HORIZONTAL CROSS SECTION

Interior View

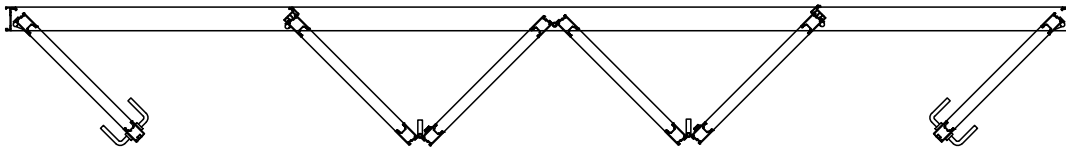

Exterior View

DESIGN PRESSURE CHART

HVHZ & Wind Zone 3

		Panel Width									
		20	24	28	32	36	40	44	48	52	
Panel Height	72	65	65	65	65	65	65	65	65	65	HVHZ
	78	65	65	65	65	65	65	65	65	65	
	84	65	65	65	65	65	65	65	65	65	
	90	65	65	65	65	65	65	65	65	65	
	96	65	65	65	65	65	65	65	65	65	
	102	65	65	65	65	65	65	65	65		
	108	65	65	65	65	65	65	65	65		
	114	65	65	65	65	65	65	65			
	120	65	65	65	65	65	65				
	126	65	65	65	65	65	65				
	132	65	65	65	65	65					
	138	65	65	65	65	65					
	144	65	65	65	65	65					
	150	65	65	65	65						
	156	65	65	64.9	64.3						
	162	65	65	57.9	57						
168	65	60.4	51.9	50.9							

WIND ZONE 3

Non-Impact

		Panel Width								
		20	24	28	32	36	40	44	48	52
Panel Height	72	100	100	100	100	100	97.5	88.6	81.3	75
	78	100	100	100	100	100	97.5	88.6	81.3	75
	84	100	100	100	100	100	97.5	88.6	81.3	75
	90	100	100	100	100	100	97.5	88.6	81.3	75
	96	100	100	100	100	100	97.5	88.6	81.3	75
	102	100	100	100	98.7	88.6	80.7	74.4	69.2	64.9
	108	100	100	93.8	82.8	75	68.1	65	59.6	55
	114	100	92.2	79.5	75	75	68.1	65	59.6	55
	120	94.2	78.9	75	75	68.1	63.5	58.3	54	50.4
	126	81.3	75	74.4	65.5	65	58.5	53.2	48.8	45
	132	75	75	65	65	65	58.5	53.2	48.8	
	138	75	65.6	65	65	65	58.5	53.2	48.8	
	144	69	65	65	65	58.5				
	150	65	65	65	64.3	57.4				
	156	65	65	64.9	57	50.9				
	162	65	65	57.9	50.9					
	168	65	60.4	51.9	45.6					
	174	65	54.3	46.7						
180	58.7	49	42.1							

TEST PERFORMANCE RESULTS

- Approved for use in Miami-Dade HVHZ Zone
- Florida Building Code Approved
Product Approval FL 17838
- Air Infiltration: ASTM E283-04
- Water Infiltration: ASTM E331-00
- Wind Load: TAS 202-94
- Large Missile Impact: TAS 201-94
- Cyclic Load: TAS 203-94
- Forced Entry: ASTM F842-14





EURO-WALL 10 YEAR WARRANTY

Euro-Wall warrants the products to be free from manufacturing defects for a period of 10 years from the date of purchase.

888.989.EURO (3876)

www.euro-wall.com

MANUFACTURING

2200 Murphy Court
North Port, Florida 34289
888.989.3876 • 941.979.5316



SHOWROOM

1211 Stirling Road, Unit 102,
Dania Beach, Florida 33004
954.610.2572

Proud Member of the American Architectural Manufacturers Association.



NOTICING

Monroe County, FL

PROPERTY RECORD CARD

Disclaimer

The Monroe County Property Appraiser's office maintains data on property within the County solely for the purpose of fulfilling its responsibility to secure a just valuation for ad valorem tax purposes of all property within the County. The Monroe County Property Appraiser's office cannot guarantee its accuracy for any other purpose. Likewise, data provided regarding one tax year may not be applicable in prior or subsequent years. By requesting such data, you hereby understand and agree that the data is intended for ad valorem tax purposes only and should not be relied on for any other purpose.

By continuing into this site you assert that you have read and agree to the above statement.

Summary

Parcel ID 00012510-000000
Account# 1012882
Property ID 1012882
Millage Group 10KW
Location Address 620 DUVAL St, KEY WEST
Legal Description KW PT LOTS 1 & 2 SQR 62 G10-140 OR217-493 OR292-240 OR532-302 OR560-637 OR638-636 OR638-638 OR638-643 OR1844-1688/95
(Note: Not to be used on legal documents.)
Neighborhood 32050
Property Class STORE COMBO (1200)
Subdivision
Sec/Twp/Rng 06/68/25
Affordable No
Housing



Owner

[OLD TOWN KEY WEST DEVELOPMENT LTD](#)
PO Box 1237
Key West FL 33041

Valuation

	2025 Certified Values	2024 Certified Values	2023 Certified Values	2022 Certified Values
+ Market Improvement Value	\$1,395,555	\$706,697	\$953,611	\$953,611
+ Market Misc Value	\$19,495	\$15,111	\$15,111	\$14,597
+ Market Land Value	\$5,234,670	\$4,112,955	\$4,112,955	\$4,112,955
= Just Market Value	\$6,649,720	\$4,834,763	\$5,081,677	\$5,081,163
= Total Assessed Value	\$4,398,129	\$3,511,638	\$3,232,733	\$2,938,849
- School Exempt Value	\$0	\$0	\$0	\$0
= School Taxable Value	\$6,649,720	\$4,834,763	\$5,081,677	\$5,081,163

Public Meeting Notice

The Historic Architectural Review Commission will hold a public meeting at 5:00 p.m. May 26, 2026, at City Hall, 1300 White Street, Key West, Florida. The purpose of the hearing will be to consider a request for:

NEW 8-FOOT-TALL FOLDING DOORS ON FRONT ELEVATION.
DEMOLITION OF NON-HISTORIC STOREFRONT.

#618 DUVAL STREET

Applicant –Rick Milelli Application #C2026-0029

If you wish to see the application or have any questions, you may visit the Growth Management Department during regular office hours at 1300 White Street, call 305-809-3973 or visit our website at www.cityofkeywest-fl.gov.

THIS NOTICE CAN NOT BE REMOVED FROM THE SITE UNTIL HARC FINAL DETERMINATION

ADA ASSISTANCE: It is the policy of the City of Key West to comply with all requirements of the Americans with Disabilities Act (ADA). Please call the TTY number at 800-955-8771 or 800-955-8770 (Voice) or the ADA Coordinator at 305-809-3811 at least five business days in advance for sign language interpreters, assistive listening devices, or materials in accessible format.

HARC POSTING AFFIDAVIT

STATE OF FLORIDA:
COUNTY OF MONROE:

BEFORE ME, the undersigned authority, personally appeared RICHARD J MILELLI, who, first being duly sworn, on oath, depose and says that the following statements are true and correct to the best of his/her knowledge and belief:

1. That a legal notice for Public Notice of Hearing of the Historic Architectural Review Commission (HARC) was placed on the following address: 618 DUVAL ST on the 20 day of MAY, 2026.

This legal notice(s) contained an area of at least 8.5"x11".

The property was posted to notice a public hearing before the Key West Historic Architectural Review Commission to be held on MAY 26, 2026.

The legal notice(s) is/are clearly visible from the public street adjacent to the property.

The Certificate of Appropriateness number for this legal notice is C2026-0029

2. A photograph of that legal notice posted in the property is attached hereto.

Signed Name of Affiant:

[Signature]
 Date: 5/21/26
 Address: 13 Bamboo Terr.
 City: Key West
 State, Zip: FL 33040

The forgoing instrument was acknowledged before me on this 21 day of MAY, 2026.

By (Print name of Affiant) Richard J. Milelli who is personally known to me or has produced _____ as identification and who did take an oath.

NOTARY PUBLIC

Sign Name: [Signature]
 Print Name: Gerzale R. Curry Hill
 Notary Public - State of Florida (seal)
 My Commission Expires: _____

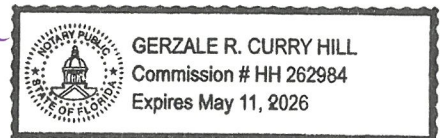

COWBOY BILL'S

COWBOY BILL'S

618

EMPOURIUM

KAYA
ISLAND EATS

LIVE MUSIC
& KARAOKE

THE

\$5

KAYA
PATIO SEATING
AVAILABLE IN BACK

OUTDOOR PATIO
SEATING AVAILABLE



620

5

KEY WEST



Live Music & KARAOKE

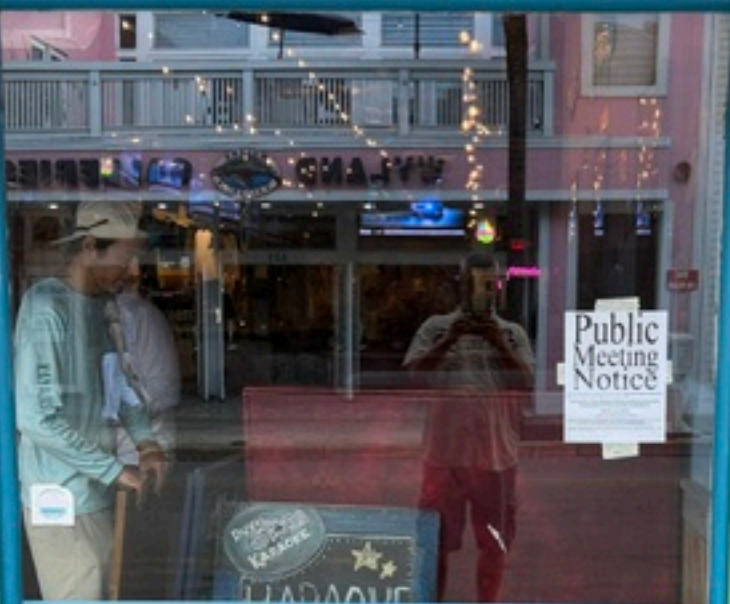

OUTDOOR PATIO
SEATING AVAILABLE



BEL

PROPERTY APPRAISER INFORMATION

Historical Assessments

Year	Land Value	Building Value	Yard Item Value	Just (Market) Value	Assessed Value	Exempt Value	Taxable Value	Maximum Portability
2024	\$4,112,955	\$706,697	\$15,111	\$4,834,763	\$3,511,638	\$0	\$4,834,763	\$0
2023	\$4,112,955	\$953,611	\$15,111	\$5,081,677	\$3,232,733	\$0	\$5,081,677	\$0
2022	\$4,112,955	\$953,611	\$14,597	\$5,081,163	\$2,938,849	\$0	\$5,081,163	\$0
2021	\$1,682,573	\$974,511	\$14,597	\$2,671,681	\$2,671,681	\$0	\$2,671,681	\$0
2020	\$1,682,573	\$984,407	\$14,685	\$2,681,665	\$2,681,665	\$0	\$2,681,665	\$0
2019	\$1,682,573	\$1,015,757	\$14,774	\$2,713,104	\$2,639,931	\$0	\$2,713,104	\$0
2018	\$1,682,573	\$932,234	\$14,862	\$2,629,669	\$2,399,938	\$0	\$2,629,669	\$0

The Maximum Portability is an estimate only and should not be relied upon as the actual portability amount. Contact our office to verify the actual portability amount.

Land

Land Use	Number of Units	Unit Type	Frontage	Depth
(1200)	16,618.00	Square Foot	0	0

Buildings

Building ID	39565	Exterior Walls	MIN WOOD SIDING	
Style		Year Built	1924	
Building Type	1 STY STORE-B / 11B	EffectiveYearBuilt	1995	
Building Name		Foundation	CONCRETE SLAB	
Gross Sq Ft	10035	Roof Type	FLAT OR SHED	
Finished Sq Ft	7650	Roof Coverage	ROLLED COMPOS	
Stories	2 Floor	Flooring Type		
Condition	AVERAGE	Heating Type	FCD/AIR DUCTED	
Perimeter	779	Bedrooms	0	
Functional Obs	0	Full Bathrooms	0	
Economic Obs	0	Half Bathrooms	0	
Depreciation %	40	Grade	450	
Interior Walls		Number of Fire Pl	0	
Code	Description	Sketch Area	Finished Area	Perimeter
CAN	CANOPY	70	0	34
OPX	EXC OPEN PORCH	24	0	21
FLA	FLOOR LIV AREA	7,650	7,650	873
OPU	OP PR UNFIN LL	128	0	48
PDO	PATIO DIN OPEN	2,163	0	280
TOTAL		10,035	7,650	1,256

Building ID	268	Exterior Walls	AVE WOOD SIDING	
Style		Year Built	2004	
Building Type	APTS-A / 03A	EffectiveYearBuilt	2004	
Building Name		Foundation	WD CONC PADS	
Gross Sq Ft	440	Roof Type	GABLE/HIP	
Finished Sq Ft	300	Roof Coverage	METAL	
Stories	1 Floor	Flooring Type	SFT/HD WD	
Condition	GOOD	Heating Type	FCD/AIR DUCTED	
Perimeter	70	Bedrooms	1	
Functional Obs	0	Full Bathrooms	1	
Economic Obs	0	Half Bathrooms	0	
Depreciation %	26	Grade	400	
Interior Walls	DRYWALL	Number of Fire Pl	0	
Code	Description	Sketch Area	Finished Area	Perimeter
FLA	FLOOR LIV AREA	300	300	70
OPU	OP PR UNFIN LL	140	0	54

Code	Description	Sketch Area	Finished Area	Perimeter
TOTAL		440	300	124

Building ID 66668
Style 2 STORY ELEV FOUNDATION
Building Type M.F. - R4 / R4
Building Name 7 Aronovitz Ln
Gross Sq Ft 3636
Finished Sq Ft 2700
Stories 2 Floor
Condition EXCELLENT
Perimeter 0
Functional Obs 0
Economic Obs 0
Depreciation % 1
Interior Walls DRYWALL

Exterior Walls HARDIE BD
Year Built 2024
EffectiveYearBuilt 2024
Foundation CONC PILINGS
Roof Type GABLE/HIP
Roof Coverage METAL
Flooring Type
Heating Type FCD/AIR DUCTED
Bedrooms
Full Bathrooms 4
Half Bathrooms 0
Grade 500
Number of Fire Pl 0

Code	Description	Sketch Area	Finished Area	Perimeter
FLA	FLOOR LIV AREA	2,700	2,700	328
OPU	OP PR UNFIN LL	126	0	54
OUU	OP PR UNFIN UL	270	0	66
OPF	OP PRCH FIN LL	250	0	70
OUF	OP PRCH FIN UL	250	0	70
SBU	UTIL UNFIN BLK	40	0	26
TOTAL		3,636	2,700	614

Yard Items

Description	Year Built	Roll Year	Size	Quantity	Units	Grade
BRICK PATIO	1975	1976	0 x 0	1	2346 SF	1
WOOD DECK	1979	1980	0 x 0	1	190 SF	1
FENCES	1985	1986	0 x 0	1	848 SF	2
TIKI	1989	1990	16 x 16	1	256 SF	5
FENCES	1989	1990	0 x 0	1	360 SF	4
FENCES	2003	2004	100 x 6	1	600 SF	2

Permits

Number	Date Issued	Status	Amount	Permit Type	Notes
BLD2024-1711	06/21/2024	Completed	\$21,600	Commercial	Install a new 27SQ 5V-Crimp metal roofing system with Grace Ice & Water Shield to the new construction.
BLD2024-1513	06/04/2024	Completed	\$0	Commercial	Installation of underground fire main.
BLD2024-1508	06/03/2024	Completed	\$0	Commercial	Installation of 44 heads and 1 riser
BLD2024-0891	04/16/2024	Completed	\$555,000	Commercial	Build 4 unit apartment building, approved HARC2023-0033. Build foundation, stairs, porch, lattice. *REVISION 1* REV 1 - ADD 32SQFT Shed for Washer and Dryer at 7 Aronovitz \$5000
BLD2024-0896	04/15/2024	Completed	\$0	Commercial	Multit 4 Units Apts Mechancial, Rough, Final Mechanical as per plans for 4 units, Build Ducts, Install 4 (2ton complete Systems) - See Bld Permit # BLD2024-0891 Main Permit
BLD2024-0894	04/09/2024	Completed	\$0	Commercial	Multit 4 Units Apts Plumbing, Rough In and Final Plumbing as per plans for 4 units - See Bld Permit # BLD2024-0891
BLD2024-0893	04/08/2024	Completed	\$0	Commercial	Multit 4 Units Apts Electrical Wire Electrical as per plans - See Bld Permit # BLD2024-0891 Main Permit

Number	Date Issued	Status	Amount	Permit Type	Notes
BLD2024-0892	04/05/2024	Canceled	\$0	Commercial	THIS PERMIT WAS VOIDED.
BLD2023-2518	09/11/2023	Completed	\$45,000	Residential	Demo All Structures and Foundation due to Fire (7 Aronovitz Ln on 620 Duval St) Building Permit to Follow
BLD2020-0529	02/20/2020	Completed	\$2,000	Commercial	ELECTRICAL-REMOVE AFTER THE FACT FIXTURES UNDER AWNING & CAP MAIN CIRCUIT IN THE FRONT OF THE BULDING AS SITED BY CODE.
BLD2019-4433	12/26/2019	Active	\$6,500	Commercial	PRESSURE WASH, PAINT TO MATCH EXISTING, REPLACE EXISTING WOOD SHUTTERS TO MATCH EXISTING
17-00001430	04/17/2017	Expired	\$3,200	Commercial	SALSA LOCA: REMOVE EXISTING DETERIORATING GREEN WALL SIDING TITLE FROM ALL OF SALSA LOCA BOTTOM TO MATCH EXISTING BACK BAR WITH GALVALUME ON THE BOTTOM AND THE TOP AREA TO BE BARN WOOD 3 N.O.C. REQUIRED. *HARC INSPECTION REQUIRED**
15-00004879	11/17/2016	Completed	\$3,800	Commercial	R/R ALL ROTTEN TRIM AND PAINT TO MATCH EXISTING. REMOVE & RELOCATE EXISTING DOUBLE SINGLE LITE WOOD DOOR TO MATCH EXISTING. N.O.C. REQUIRED. H15-01-1834-12/02/15-KP. NEW STORE FRONT CONFIGUATION TO MATCH EXISTING/NEIGHBORING IN MATERIALS PROFILE. NEW WINDOW TO MATCH EXISTING IN MATERIAL & LOOK.
16-00003591	11/17/2016	Expired	\$2,200	Commercial	EMERGENCY: DEMO EXISTING INTERIOR FINISHES FOR EXPLORATION APPROX. 320 SQ/FT OF SLAT WALL SCREWED OVER EXISTING MIRROR AND ORIGINAL DRYWALL AND WAINSCOT TO BE DONE ON PERIMETER INTERIOR WALLS. N.O.C. REQUIRED. GH **NON-STRUCTURAL EXPLORATORY DEMOLITION**.
15-4879	01/27/2016	Completed	\$3,800	Commercial	R/R ROTTEN TRIM AND PAINT
15-00002111	05/31/2015	Completed	\$27,808	Commercial	COAT THE AGING "SBS' MODIFIED BITUMEN SINGLE PLY ROOF. (NOC REQUIRED). HARC #15-01-0814-HSA-5/28/15-KP
14-0812	05/20/2014	Expired	\$32,800	Commercial	REMOVE AND REPLACE 110LF OF SPALLING, COLUMN AND BEAMS. INSTALL APPROX. 800SF OF STUCCO TOP COAT
14-2100	05/20/2014	Completed	\$30,800	Commercial	REPAIR CONCRETE ON BUILDING; REMOVE AND REPLACE 110 LF OF SPALLING, COLUMNS AND BEAMS. INSTALL APPROX 800SF OF STUCCO TOP COAT
13-4735	11/04/2013	Completed	\$800	Commercial	RELOCATE ONE SMOKE DETECTOR, ONE QUAD OUTLET, REMOVE AND RELOCATE TWO SWITCHES AND TWO OUTLETS.
13-4656	11/01/2013	Completed	\$3,276	Commercial	BUILD A 6' METAL FRAMED WALL NON-BEARING LOAD BEARING. FASTENED TO EXISTING ROOF RAFTERS. INSTALL 5/8 DRYWALL 468SF
13-1002	03/14/2013	Completed	\$500	Commercial	REMOVE UNPERMITTED WIRING AND RESTORE BACK TO ORIGINAL CONFIGURATION
12-2497	07/10/2012	Completed	\$2,400	Commercial	BUILD A WALL 14 X 6 WITH DOOR 36", 84 SF DJ BATH AT FRONT RIGHT SIDE OF RESTAURANT (INTERIOR WORK) AS PER PLANS.
12-2346	06/28/2012	Completed	\$2,350	Commercial	REPAIR UNDERGROUND FITTINGS.
11-0458	02/11/2011	Completed	\$2,400	Commercial	REMOVE 40 X 9 PARTITION WALL ONLY. NO REPAIR OF ELECTRICAL NECESSARY
09-2404	09/02/2009	Completed	\$1,900	Commercial	CHANGE EXISTING AWNING COVER TO RED, PAINT WALLS WHITE
09-2403	08/18/2009	Completed	\$1,500	Commercial	INSTALL THREE NEW FIXTURES, ONE TRIPLE COMPACT SINK, ONE HAND SINK AND ONE 25 GALLON GREASE TRAP.
09-2402	08/14/2009	Completed	\$1,900	Commercial	INSTALL EIGHT NEW OUTLETS, FOUR OUTLETS IN T-SHIRT AREA, WIRING 3000SF NEW BAR.
09-2401	08/13/2009	Completed	\$24,000	Commercial	INSTALLATION OF 34' OF BAR, APPROXIMATELY 100SF OF BRICK VANER ON BAR FACE, APPROXIMATELY 100SF OF FRP PANEL ON BAR AREA, 90LF OF NON-STRUCTURAL WALL, 400LF OF WAINSCOT ON LOWER WALLS, 60LF OF INTERIOR DECORATIVE MANSARD ROOF.
08-3300	09/06/2008	Completed	\$2,000	Commercial	INSTALL TWO HURRICANE PANELS ON TWO WINDOWS AND ONE DOOR
08-2850	08/08/2008	Completed	\$4,500	Commercial	REPLACE AND UPGRADE 5 METER BANK WITH 3 METER BANK. UP-GRADE ONE 100 AMP DERVICE TO 200 AMP. UPGRADE ONE 100 AMP TO 150 AMP, REPLACE ONE 100 AMP SERVICE.
08-2180	06/23/2008	Completed	\$1,900	Commercial	REPLACE 100 AMP SERVICE WITH 200AMP ERVICE, ELIMINATE 100 AMP SERVICE.
06-5000	09/13/2006	Completed	\$15,000	Commercial	BUILD DANCE FLOOR 750SF.,REPLACE EXISTING DECK,BUILD NEW HANDICAP RAMP
06-4015	07/28/2006	Completed	\$2,200	Commercial	REMOVE/REPLACE 6X6 SUPPORT POST
06-4366	07/18/2006	Completed	\$1,000	Commercial	REMOVE/REPLACE DAMAGED WIRING
05-3907	09/09/2005	Completed	\$1,200	Commercial	REPLACE 3 100AMP PANELS WITH 100AMP BREAKERS
04-3161	10/01/2004	Completed	\$2,000	Commercial	REPAIR ROOF
04-3154	09/29/2004	Completed	\$1,900	Commercial	14 BAR FIXTURES
04-3046	09/17/2004	Completed	\$1,600	Commercial	ELECTIC FOR BARS
04-2763	08/20/2004	Completed	\$7,976	Commercial	REPAIR BARS
04-2614	08/05/2004	Completed	\$11,500	Commercial	A/C
04-2552	07/29/2004	Completed	\$2,000	Commercial	REPAIR EXTERIOR
03-4225	05/14/2004	Completed	\$34,450	Commercial	CONVERT GAZEBO TO SFR
04-0725	03/10/2004	Completed	\$2,000	Commercial	ELECTRICAL
03/4225	01/15/2004	Completed	\$300		ROOF FOR ADDITION
03/4225	01/15/2004	Completed	\$4,100		WIRE ADDITION
03-3020	08/27/2003	Completed	\$2,500	Commercial	NEW SEWER LINE
03-1609	05/05/2003	Completed	\$8,500	Commercial	CHANGE TWO A/C,

Number	Date Issued	Status	Amount	Permit Type	Notes
03/0876	03/20/2003	Completed	\$2,300		INST WOOD FENCE 100X6
03-0876	03/20/2003	Completed	\$2,300	Commercial	BUILD 100'X6' FENCE
02-3054	02/19/2003	Completed	\$8,050	Commercial	REVISED ELEC.
02-0107	01/07/2003	Completed	\$6,550	Commercial	HOOK UP GAZEBO
02-3357	12/16/2002	Completed	\$1,500	Commercial	REPLACE METER CAN
02-3054	11/15/2002	Completed	\$4,650	Commercial	RELOCATE GAZEBO
02-2597	09/24/2002	Completed	\$60,000	Commercial	REROOF
02-0166	01/18/2002	Completed	\$655	Commercial	REPAIRS TO ROOF
01-3496	10/23/2001	Completed	\$3,200	Commercial	100 AMP PANEL
01-1991	05/18/2001	Completed	\$3,500	Commercial	ELECTRICAL FIXTURES
00-4405	01/03/2001	Completed	\$700	Commercial	REPAIR SPALLED CONCRETE
00-1872	07/06/2000	Completed	\$350	Commercial	ELECTRICAL
00-0744	04/05/2000	Completed	\$6,144	Commercial	PAINT ROOF
00-0051	01/07/2000	Completed	\$8,000	Commercial	ROOF
99-3404	09/29/1999	Completed	\$4,200	Commercial	CHANGEOUT 5 TON AC
99-3073	09/22/1999	Completed	\$6,000	Commercial	REPAIRS
9802539	09/02/1998	Completed	\$5,000	Commercial	REMODEL STOREFRONT
9701692	06/01/1997	Completed	\$200	Commercial	SIGN
9701367	05/01/1997	Completed	\$2,500	Commercial	RENOVATIONS
9701401	05/01/1997	Completed	\$500	Commercial	REPAIR WOOD DECK
9701422	05/01/1997	Completed	\$500	Commercial	PLUMBING
9701167	04/01/1997	Completed	\$20,000	Commercial	RENOVATIONS
9701314	04/01/1997	Completed	\$1,000	Commercial	ALTERATIONS
B951183	04/01/1995	Completed	\$2,400	Commercial	REPLACE 500SF WOOD SIDING

View Tax Info

[View Taxes for this Parcel](#)

Sketches (click to enlarge)

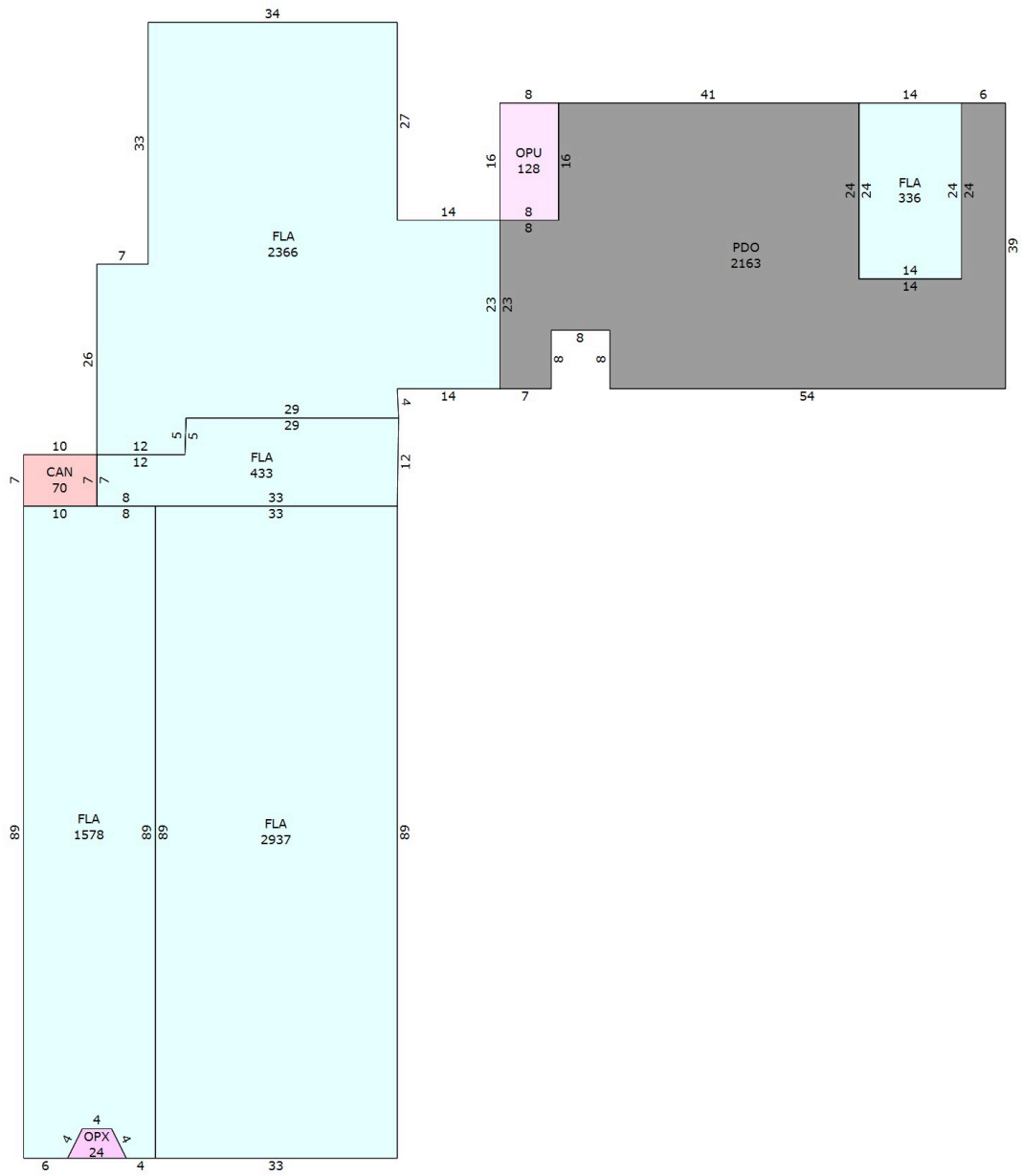



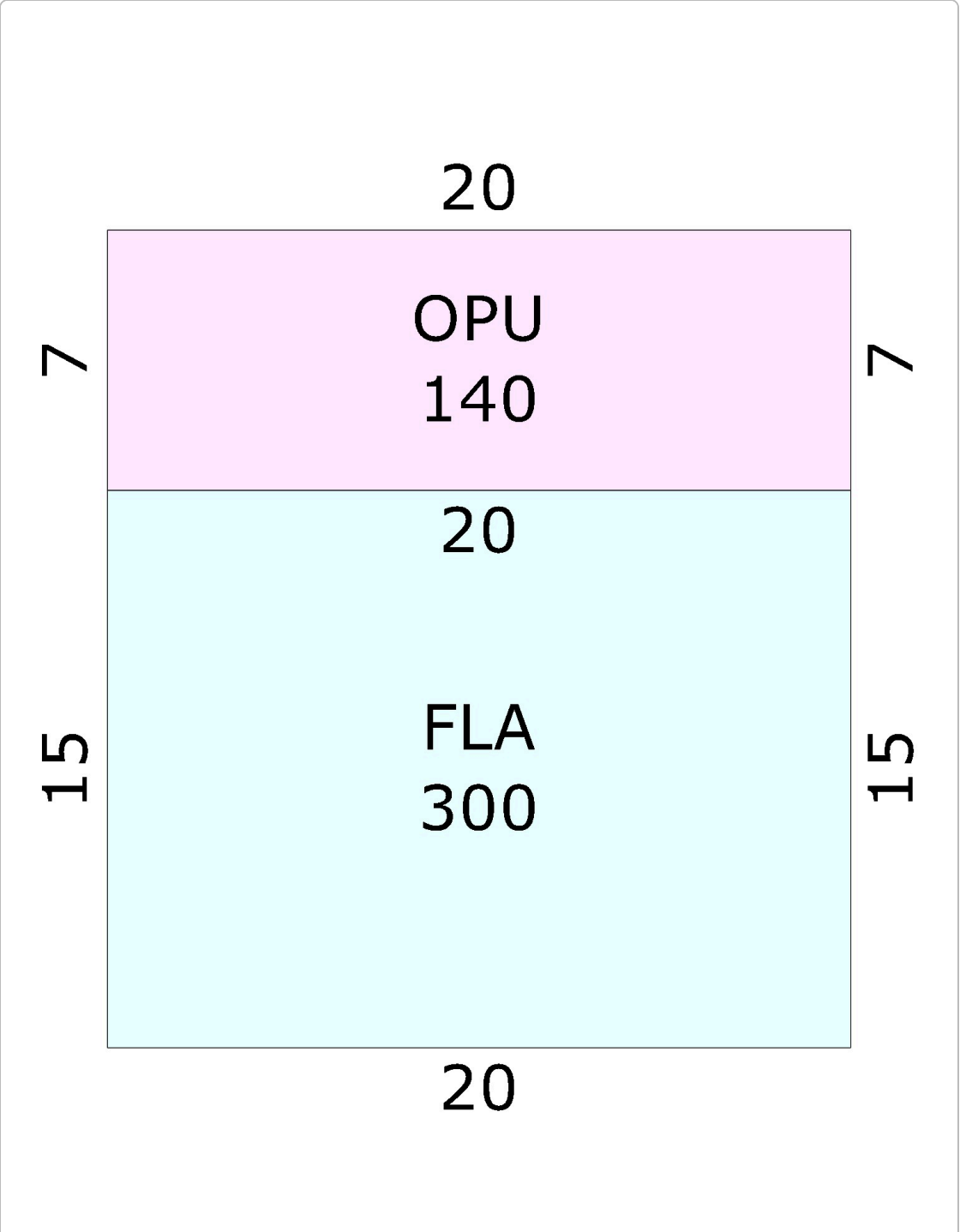

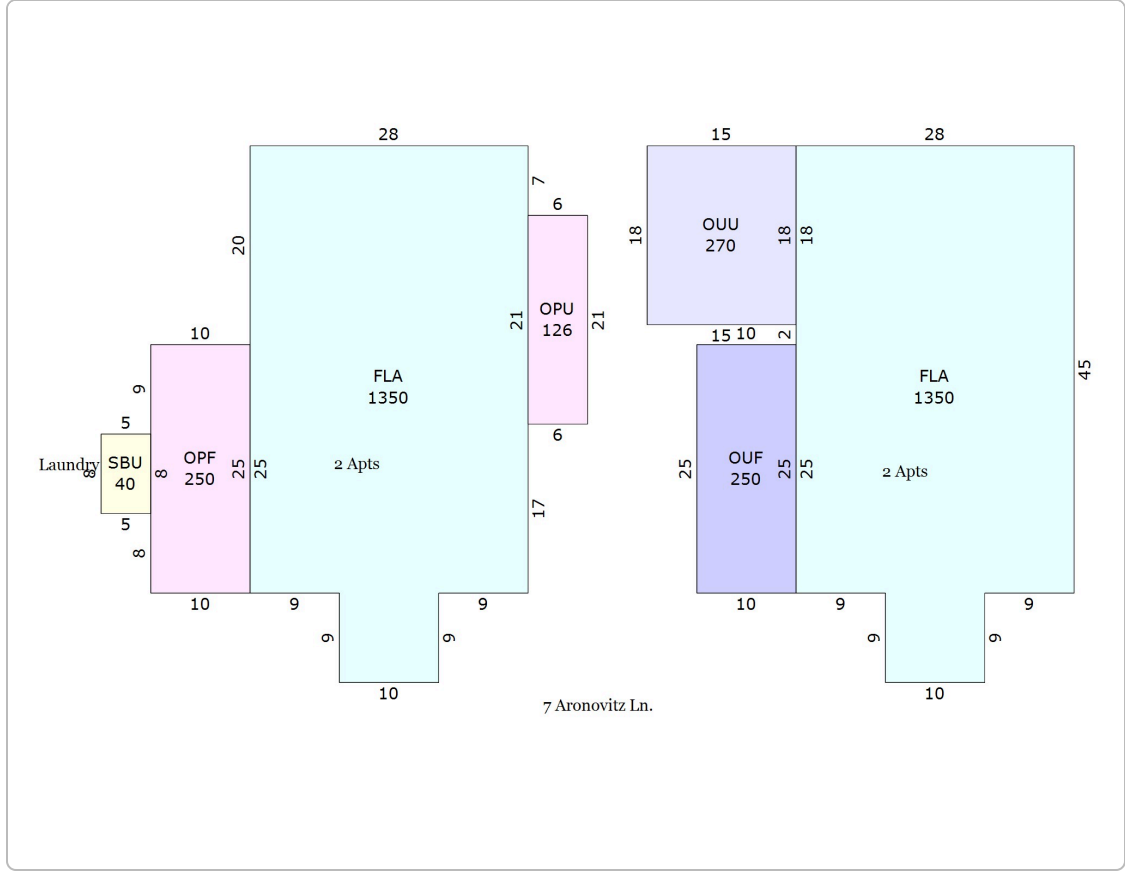

Photos



Map



TRIM Notice

[2025 TRIM Notice \(PDF\)](#)

No data available for the following modules: Sales.

The Monroe County Property Appraiser's office maintains data on property within the County solely for the purpose of fulfilling its responsibility to secure a just valuation for ad valorem tax purposes of all property within the County. The Monroe County Property Appraiser's office cannot guarantee its accuracy for any other purpose. Likewise, data provided regarding one tax year may not be applicable in prior or subsequent years. By requesting such data, you hereby understand and agree that the [User Privacy Policy](#) | [GDPR Privacy Notice](#)
Last Data Upload: 5/20/2026, 11:13:15 PM

[Contact Us](#)

Developed by
 **SCHNEIDER**
GEOSPATIAL