



## FLORIDA SHERIFFS ASSOCIATION & FLORIDA ASSOCIATION OF COUNTIES

Name of Dealership	Type of Vehicle	Zone	Base Unit Price
<u>CABOVER MECHANICAL BROOM STREET SWEEPER (Specification #51)</u>			
Environmental Products of Florida	2016 Elgin Eagle	Western	\$270,816.00
Environmental Products of Florida	2016 Elgin Eagle	Northern	\$270,816.00
Environmental Products of Florida	2016 Elgin Eagle	Central	\$270,816.00
Environmental Products of Florida	2016 Elgin Eagle	Southern	\$270,816.00
Southern Sewer Equipment Sales	2016 Global Python 2500	Western	\$288,071.00
Southern Sewer Equipment Sales	2016 Global Python 2500	Northern	\$288,071.00
Southern Sewer Equipment Sales	2016 Global Python 2500	Central	\$288,071.00
Southern Sewer Equipment Sales	2016 Global Python 2500	Southern	\$288,071.00
Southern Sewer Equipment Sales	2016 Schwarze M6 Avalanche	Western	\$269,889.00
Southern Sewer Equipment Sales	2016 Schwarze M6 Avalanche	Northern	\$269,889.00
Southern Sewer Equipment Sales	2016 Schwarze M6 Avalanche	Central	\$269,889.00
Southern Sewer Equipment Sales	2016 Schwarze M6 Avalanche	Southern	\$269,889.00
G S Equipment, Inc.	2016 Stewart-Amos Starfire S-5	Western	\$263,125.00
G S Equipment, Inc.	2016 Stewart-Amos Starfire S-5	Northern	\$263,125.00
G S Equipment, Inc.	2016 Stewart-Amos Starfire S-5	Central	\$263,125.00
G S Equipment, Inc.	2016 Stewart-Amos Starfire S-5	Southern	\$263,125.00
Pat's Pump & Blower	2016 Wayne Gladiator	★ Western	\$261,546.00
Pat's Pump & Blower	2016 Wayne Gladiator	★ Northern	\$261,546.00
Pat's Pump & Blower	2016 Wayne Gladiator	★ Central	\$261,546.00
Pat's Pump & Blower	2016 Wayne Gladiator	★ Southern	\$261,546.00



## FLORIDA SHERIFFS ASSOCIATION & FLORIDA ASSOCIATION OF COUNTIES

### CABOVER MECHANICAL BROOM STREET SWEEPER SPECIFICATION #51

2016 Elgin Eagle  
2016 Global Python 2500  
2016 Schwarze M6 Avalanche  
2016 Stewart-Amos Starfire S-5  
2016 Wayne Gladiator

**ALL ITEMS FACTORY INSTALLED UNLESS OTHERWISE INDICATED**

**INSTRUCTIONS:** Listed above, you will find the model numbers of the vehicles that will be included in this year's contract.

#### 1. CAB & CHASSIS:

- a. Engine:
- b. 6 cylinder diesel 200 HP minimum
- c. Transmission:
- d. Automatic transmission to meet the correct engine size and GVW of vehicle. Hydrostatic drive is acceptable.
- e. Engine Equipment:
- f. Alternator - 12V / 130 AMP
- g. Fuel water separator
- h. Fuel tank – 50 gallon
- i. Cab:
- j. Dual operating position type cab to include: Steering, controls, etc for sweeping from either side.
- k. Rubber floor mats
- l. Air ride seating
- m. Pressurized cab with heat and air conditioning
- n. Instrumentation for truck - oil pressure, water temperatures, voltmeter gauges
- o. Instrumentation for sweeper-tachometer, hour meter, oil pressure, coolant temperature gauges
- p. Frame:
- q. Rail type 80,000 psi
- r. Size – 10.9" x 3.5" x .34"
- s. Frame overhang
- t. Wheelbase 130" minimum
- u. Front steel bumper
- v. Safety:
- w. Dual West Coast bright finish heated mirrors with LH & RH remote
- x. Intermittent windshield wipers
- y. Daytime running lights
- a'. Backup alarm
- aa. Auto shutdown
- ab. Axles:
- ac. Front axle: 11,900 lb. GVW
- ad. Rear axle: 21,000 lb. GVW
- ae. Single speed rear axle.
- af. 22.5 x 8.25 steel wheels - disc type
- ag. 11R x 22.5 14-ply radial tires
- ah. Brakes:

- ai. Antilock brakes
- aj. Front air brakes - 15 x 4 drum
- ak. Rear air brakes 16.5 x 7 drum
- al. Automatic slack adjusters - front and rear
- am. Air dryer - frame mounted

2. MOUNTED SWEEPER BODY (STANDARD EQUIPMENT):

- a. Engine:
  - b. 4 cylinder diesel - 47 horsepower, governed at 2800 RPM
  - c. Spin-on oil filter
  - d. Alternator – 12V / 60AMP
- e. Side Brooms:
  - f. Right & left side gutter brooms (tilt control in cab)
  - g. Hydraulically raised & lowered
  - h. 42" diameter – segment type
  - i. Adjustable down pressure (Manual) – optional down pressure pump
- j. Main Broom:
  - k. Length - 58" minimum
  - l. Diameter - 35" minimum
- m. Hydraulic motor - direct or chain drive and reversible
- n. Full floating trailing arms w/shocks
- o. Lift Control – inside cab
- p. Sweeper Body:
  - q. Overall height – 10' with strobe
  - r. Lift capacity – 11,000 lbs minimum
  - s. 4.5 cubic yard hopper
  - t. Dump height - 10' minimum
  - u. Lift design – hydraulic 2-stage scissors
  - v. Hopper inspection door
- w. Work lights – 1 on each gutter broom and one in rear
- x. Hydraulic System:
  - y. Hydraulic pump capacity minimum – 24gpm@2600rpm
  - a`. Pump: dual tandem gear
  - aa. Reservoir – 21 gallons
  - ab. Spin-on 10 micron hydraulic pump
  - ac. Externally mounted reservoir level indicator
- ad. Water Spray System:
  - ae. Water tank construction – polyethylene and removable
  - af. Water tank capacity - 280 gallons minimum
  - ag. Fill hose 2 1/2" x 16' with NST coupler
  - ah. Diaphragm pump type with run dry capability
  - ai. Pump capacity – 3.0 GPM minimum
  - aj. Minimum of 9 spray nozzles – 2 min per gutter broom, 3 min for main broom
  - ak. Water filter – 80 micron mesh cleanable
- al. Conveyor/Elevator System:
  - am. Minimum of 9 flights – replaceable
  - an. Belt material – rubber reinforced fabric
  - ao. Belt speed – variable with auxiliary engine RPM
  - ap. Drive – reversible with direct drive
  - aq. Elevator jam warning light & buzzer in cab
  - ar. Conveyer flush – built in



**FLORIDA SHERIFFS ASSOCIATION  
& FLORIDA ASSOCIATION OF COUNTIES**

**CABOVER MECHANICAL BROOM STREET SWEEPER  
SPECIFICATION #51**

**2016 Elgin Eagle**

The Elgin Eagle purchased through this contract comes with all the standard equipment as specified by the manufacturer for this model and FSA's base vehicle specification(s) requirements which are included and made a part of this contract's vehicle base price as awarded by specification by zone.

<b>ZONE:</b>	Western	Northern	Central	Southern
<b>BASE PRICE:</b>	\$270,816.00	\$270,816.00	\$270,816.00	\$270,816.00

While the Florida Sheriffs Association and Florida Association of Counties have attempted to identify and include those equipment items most often requested by participating agencies for full size vehicles, we realize equipment needs and preferences are going to vary from agency to agency. In an effort to incorporate flexibility into our program, we have created specific add/delete options which allow the purchaser to tailor the vehicle to their particular wants or needs.

The following equipment delete and add options and their related cost are provided here to assist you in approximating the total cost of the type vehicle(s) you wish to order through this program. Simply deduct the cost of any of the following equipment items you wish deleted from the base unit cost and/or add the cost of any equipment items you wish added to the base unit cost to determine the approximate cost of the type vehicle(s) you wish to order.

NOTE: An official listing of all add/delete options and their prices should be obtained from the appropriate dealer in your zone when preparing your order. Additional add/delete options other than those listed here may be available through the dealers, however, those listed here must be honored by the dealers in your zone at the stated prices.

<b>VEHICLE:</b>	Eagle			
<b>DEALER:</b>	Environmental Products of Florida	Environmental Products of Florida	Environmental Products of Florida	Environmental Products of Florida
<b>ZONE:</b>	Western	Northern	Central	Southern
<b>BASE PRICE:</b>	\$270,816.00	\$270,816.00	\$270,816.00	\$270,816.00

Order Code	Delete Options	All Zones
1119RWF <sup>1</sup>	Delete dual operator controls	NA
1120RWR <sup>1</sup>	Conventional Chassis in lieu of Cabover Chassis	\$15,724.00 <sup>1</sup>
	Single Left Hand Steering in lieu of Dual Steering <i>RH<sup>1</sup></i>	\$10,520.00 <sup>1</sup>
	Single Gutter Broom in lieu of Dual Gutter Brooms	NA
1113BB <sup>1</sup>	Amber Strobe Light (Cab Mounted with Limb Guard)	NA
	Downgrade - specify <i>Single Engine squeegee M2 Freightliner<sup>1</sup></i>	\$26,481.00 <sup>1</sup>
5801BAD <sup>1</sup>	Downgrade - specify <i>Dual Engine Squeegee NPR<sup>1</sup></i>	\$63,397.00 <sup>1</sup>
5801BAD <sup>1</sup>	Downgrade - specify <i>Single Steer NPR<sup>1</sup></i>	\$9,600.00 <sup>1</sup>
	Downgrade - specify	
	Downgrade - specify	
	Downgrade - specify	
	Alternative cabover chassis - specify	NA
	Alternative cabover chassis - specify	NA
	Alternative cabover chassis - specify	NA
Order Code	Add Options	All Zones
1112845 <sup>1</sup>	Upgrade option - specify <i>Eagle Waterless M2<sup>1</sup></i>	\$7,588.00 <sup>1</sup>
2209078 <sup>1</sup>	Upgrade option - specify <i>M2 CNG Chassis for single engine squeegee<sup>1</sup></i>	\$66,060.00 <sup>1</sup>
1119RW <sup>1</sup>	Upgrade option - specify <i>Dual Engine Squeegee Pete<sup>1</sup></i>	\$5,893.00 <sup>1</sup>
	Upgrade option - specify	
	Upgrade option - specify	
	Upgrade option - specify	
M2 Std. <sup>1</sup>	2-speed rear axle <i>M2<sup>1</sup></i>	Std <sup>1</sup>
Std. <sup>1</sup>	Warning beacons	Std <sup>1</sup>
1103532 <sup>1</sup>	Amber strobe light (additional)	\$882.00 <sup>1</sup>
1114834 <sup>1</sup>	Rear flood lights <i>Each<sup>1</sup></i>	\$292.00 <sup>1</sup>
Std. <sup>1</sup>	Light guards	Std <sup>1</sup>
1101560 <sup>1</sup>	Automatic lubrication system	\$7,072.00 <sup>1</sup>
1104503 <sup>1</sup>	Hopper lining	\$4,525.00 <sup>1</sup>



<b>VEHICLE:</b>	Eagle			
<b>DEALER:</b>	Environmental Products of Florida	Environmental Products of Florida	Environmental Products of Florida	Environmental Products of Florida
<b>ZONE:</b>	Western	Northern	Central	Southern
<b>BASE PRICE:</b>	\$270,816.00	\$270,816.00	\$270,816.00	\$270,816.00

1101951 <sup>1</sup>	Stainless steel hopper	\$9,045.00 <sup>1</sup>
Std. <sup>1</sup>	High dump hopper assembly mounted on conventional chassis	Std <sup>1</sup>
	High pressure washdown	NA
	Abrasion protection package	NA
	Auxiliary fuse panel; 12VDC fused power source panel for additional electrical components	NA
1102759 <sup>1</sup>	Arrowstick	\$1,707.00 <sup>1</sup>
Std. <sup>1</sup>	Reverse pick-up head chains	Std <sup>1</sup>
1093073 <sup>1</sup>	Magnet assembly: 84" magnet, electromechanically activated (2-10 inch adjustment)	\$11,953.00 <sup>1</sup>
1104705 <sup>1</sup>	Hopper load indicators	\$774.00 <sup>1</sup>
	Hopper drain system	NA
	Hopper deluge system	NA
	Hi/low pressure washdown system	NA
1110919 <sup>1</sup>	Gutter broom tilt adjuster <i>Each</i> <sup>1</sup>	\$1,204.00 <sup>1</sup>
	Gutter broom - drop down (requires gutter broom tilt adjuster) each	Std
	Extra water capacity	NA
Std. <sup>1</sup>	Dump switch in cab	Std <sup>1</sup>
	Alternative cabover chassis - specify	NA
	Alternative cabover chassis - specify	NA
	Alternative cabover chassis - specify	NA
1104970 <sup>1</sup>	Optional equipment - specify <i>Hopper Up Alarm</i> <sup>1</sup>	\$354.00 <sup>1</sup>
1101380 <sup>1</sup>	Optional equipment - specify <i>Hydraulic Oil Temperature Shutdown</i> <sup>1</sup>	\$333.00 <sup>1</sup>
1102798 <sup>1</sup>	Optional equipment - specify <i>Hydraulic Oil Level Shutdown</i> <sup>1</sup>	\$343.00 <sup>1</sup>
1101379 <sup>1</sup>	Optional equipment - specify <i>Broom Hour Meter</i> <sup>1</sup>	\$369.00 <sup>1</sup>
702462 <sup>1</sup>	Optional equipment - specify <i>Service Manual</i> <sup>1</sup>	\$92.00 <sup>1</sup>
1102735 <sup>1</sup>	Optional equipment - specify <i>LED stop/tail/rear turn</i> <sup>1</sup>	\$338.00 <sup>1</sup>
1104991 <sup>1</sup>	Optional equipment - specify <i>LH Camera</i> <sup>1</sup>	\$574.00 <sup>1</sup>
1075400 <sup>1</sup>	Optional equipment - specify <i>AM/FM/CD</i> <sup>1</sup>	\$892.00 <sup>1</sup>
1117611 <sup>1</sup>	Optional equipment - specify <i>Front Spray Broom</i> <sup>1</sup>	\$1,204.00 <sup>1</sup>

<b>VEHICLE:</b>	Eagle			
<b>DEALER:</b>	Environmental Products of Florida	Environmental Products of Florida	Environmental Products of Florida	Environmental Products of Florida
<b>ZONE:</b>	Western	Northern	Central	Southern
<b>BASE PRICE:</b>	\$270,816.00	\$270,816.00	\$270,816.00	\$270,816.00

1119940 <sup>1</sup>	Optional equipment - specify <i>Air Filter Restriction Indicator</i> <sup>1</sup>	\$759.00 <sup>1</sup>
1077151 <sup>1</sup>	Optional equipment - specify <i>Strip Broom</i> <sup>1</sup>	\$251.00 <sup>1</sup>
1118107 <sup>1</sup>	Optional equipment - specify <i>High Speed Conveyor Motor</i> <sup>1</sup>	\$456.00 <sup>1</sup>
1032484 <sup>1</sup>	Optional equipment - specify <i>25' Fill Hose</i> <sup>1</sup>	\$190.00 <sup>1</sup>
1109605 <sup>1</sup>	Optional equipment - specify <i>Extended Reach Side Broom</i> <sup>1</sup>	\$1,348.00 <sup>1</sup>
1116574 <sup>1</sup>	Optional equipment - specify <i>Carbide Dirt Shoes</i> <sup>1</sup>	\$820.00 <sup>1</sup>
Temp <sup>1</sup>	Temporary tag	NC <sup>1</sup>
Tran <sup>1</sup>	Transfer existing registration (must provide tag number)	\$100.00 <sup>1</sup>
New Tag <sup>1</sup>	New state tag (specify state, county, city, sheriff, etc.)	\$150.00 <sup>1</sup>
Maint. Plan <sup>1</sup>	Maintenance Plan - specify <i>Full Maintenance per year including the chassis</i> <sup>1</sup>	\$14,400.00 <sup>1</sup>
Maint. Body <sup>1</sup>	Maintenance Plan - specify <i>Body only per year</i> <sup>1</sup>	\$9,600.00 <sup>1</sup>
Warr <sup>1</sup>	Warranty - specify <i>Per year up to 4 additional years</i> <sup>1</sup>	\$2,655.00 <sup>1</sup>
0 % Discount <sup>1</sup>	Warranty - specify	
	Discount percentage off manufacturer's current published retail prices for non-specified options and any optional models bid. This discount ONLY APPLIES to a downgrade or an upgrade to the model listed in this specification. It does not apply to a completely different make or model. (The discount is applied to the manufacturer's current published retail prices.)	<sup>1</sup>



September 25<sup>th</sup>, 2015

City of Key West  
 Elgin sweeper quotation per FSA contract  
 Attn: Mr. Richard Sarver

Dear Mr. Sarver,

The following quote is based on the most current Florida Sheriffs Association contract.  
 FSA contract 15-13-0904 specification #51.

2016 Cab-Over mechanical broom street sweeper \$270,816.00

**DELETE OPTIONS**

1113BB Single engine squeegee – 2016 M2 Freightliner \$ 26,481.00

**ADD OPTIONS**

1103532 Amber strobe lights (Qty2)	\$ 882.00
1101951 Stainless steel hopper #304 grade	\$ 9,045.00
1102759 Arrowstick rear mounted	\$ 1,707.00
1110919 Gutter broom tilt adjuster (Qty 1) RH side	\$ 1,204.00
702462 Service manual	\$ 92.00
1102735 LED stop/tail/rear turn and reverse lights	\$ 338.00
1075400 AM/FM radio install with antenna and speakers	\$ 892.00
1117611 Front bumper spray bar	\$ 1,204.00
1077151 Strip broom	\$ 251.00

**UNPUBLISHED OPTIONS**

Marine rust prohibiting coating on sweeper undercarriage	\$ 2,000.00
RFQ 2208608-55781 High pressure wash down system with reel	\$ 5,410.00
Resume sweep	NO CHARGE

---

**EPOFC IS NOW IN FORT LAUDERDALE**

**1**

2525 Clarcona Road ♦ Apopka, FL 32703  
 Phone: 407-798-0004 ♦ Fax: 407-798-0014  
 4405 Loma Vista Drive ♦ Valrico, FL 33594  
 Phone: 813-299-6264 ♦ Fax: 813-689-2498  
 450 NW 27<sup>th</sup> Avenue ♦ Fort Lauderdale, FL 33311  
 Phone: 954-518-9923 ♦ Fax: 954-518-9926  
[www.EPOFC.com](http://www.EPOFC.com)





Conveyor stall alarm	NO CHARGE
Back up camera	NO CHARGE
LH fender mount convex mirror	\$ 480.00
Upgrade to belt conveyor ILO squeegee	NO CHARGE
Quick disconnect fitting at water fill port	\$ 305.00
Power and heated mirrors	NO CHARGE
Power windows and power door locks	\$ 470.00
4 year parts warranty on sweeper	\$ 4,180.00
<b>Total delivered price per the FSA contract</b>	<b>\$272,795.00</b>
<b>Preferred customer discount</b>	<b>\$ 4,000.00</b>
<b>Total delivered price to the City of Key West after discount</b>	<b>\$268,795.00</b>

Please contact me with any questions.

Sincerely,

*Paul A. Hart*

Paul A. Hart  
 South Florida – Territory Manger  
 EPOFC  
 561-719-1395 cell  
[phart@epofc.com](mailto:phart@epofc.com)



# ELGIN®

Subsidiary of Federal Signal Corporation

## Broom Bear®





# ELGIN BROOM BEAR®

## POWERFUL, PROVEN, SINGLE ENGINE MECHANICAL SWEEPER

When contractors and municipalities need a durable sweeper that's easy and comfortable to operate, the Elgin Broom Bear is the sweeper of choice. From heavy duty construction debris, like millings or gravel, as well as light street maintenance, the Broom Bear has proven to be one of the most rugged and efficient sweepers in the industry. And the short wheelbase enhances maneuverability and makes the sweeper ideal for sweeping in tight cul-de-sacs.

Mounted on a commercially available conventional chassis with fully dualized controls and an intelligent single engine design that utilizes the chassis engine to power the sweeper, the Broom Bear features a large hopper and water tank, which means more productive sweeping time and fewer scheduled stops. A variable dumping height and 11 inch (279 mm) of hopper side-shift ensures easy dumping.



### APPLICATION SOLUTIONS

*Elgin Sweeper doesn't offer just one sweeping technology — we take an application-based approach to solving our customers' sweeping needs. Our team works with each customer to ensure that you get a machine that fits your specifications, with the right truck, engine configuration, fuel requirements, and options.*

### POWERFUL SUPPORT

*Elgin sweepers are built for clean, backed for life. Throughout the life of the sweeper, we offer training to your team on proper use and maintenance. We have a world-wide network of experienced dealers with factory trained technicians and a local stock of OEM parts and accessories to ensure total customer peace of mind.*

### UNMATCHED QUALITY

*The Broom Bear became part of the Elgin lineup 15 years ago and has been continuously improved. Manufactured in an ISO:9001 certified plant, Elgin Sweepers are quality inspected and functionally tested prior to shipment. Paint prior to assembly ensures uniform, durable coverage. Broom Bears are proudly assembled in the U.S.A.*





### HIGH PRODUCTIVITY SWEEP SYSTEM

- High torque diesel engine is teamed with Freightliner® M2 or International® Durastar® chassis to create one of the most powerful and reliable single engine packages in the industry.
- The control console, located between the operator stations, provides quick, easy access. All sweep function switches have tactile-feel surfaces, so operators can work the panel while keeping their eyes focused forward, for increased productivity and safe operation.
- Dual free-floating gutter brooms that adjust to variable road surfaces, a sweep path of 120 inches (3048 mm) with an additional extension of up to 144 inches (3657 mm) when both brooms are pinned to outer points, and a powerful free floating direct drive main broom, ensure reliable and complete pickup of debris.
- Superior dust control is maintained with in-cab zone controlled, dual diaphragm water pumps and a 360 gallon (1363 L) water tank for long sweep times between refills.
- The 4.5 cubic yard (3.4 cu meter) hopper features a double-scissor lifting mechanism that is center mounted for greater stability and trouble free operation. Dumping height is variable up to 10 feet (305 cm) and an 11 inch (279 mm) side shift enables a cleaner more efficient unloading of material. Optional 5.4 cubic yard (4.1 cu meter) hopper available.
- The chassis cab is dualized with OEM parts, including full factory controls, steering, and OEM gauge package that is identical for both left and right operator stations.





# EASY TO OPERATE. EASY TO MAINTAIN. BUILT TO LAST.



## MAIN BROOM

The main broom is attached to a fully floating trailing arm to better conform to road contours. Performance is optimized using mechanical main broom suspension that dynamically adjusts to various road conditions while on-the-go. Lift and lower functions are controlled from the cab. Main broom arm bearings are sealed, can be re-lubricated and are self-aligning for self-adjustment when experiencing an uneven load which decreases wear and increases main broom life.

## SIDE BROOMS

46 inch (1168 mm) trailing arm, free-floating side brooms offer four-way motion and protection against damaging impacts. Pneumatic lift and extension control enhances performance while sweeping within a 10 foot (3048 mm) wide path. Steel plate disc construction adds durability. Broom speed is controlled by hydraulic motors. Broom speed is constant and matched to the conveyor speed for optimal loading performance. Automatic settings control down-pressure, digging-pressure and wear-control. In-cab side broom pressure gauges and down-pressure control are standard.



## SQUEEGEE TYPE CONVEYOR

A steel roller chain drives an 11-flight, squeegee-type conveyor to load debris into the hopper. The chain operates on polyurethane sprockets, which last longer. Conveyor speed is constant and matched to the broom speed for optimal loading performance. Conveyor operating height can be raised from the cab up to 3 inches (76 mm) to avoid larger debris and other obstacles. Conveyor bearings are sealed and self-aligning for longer life.

## HYDRAULIC SYSTEM

The Broom Bear features a 23 gallon (87 L) reservoir with an external level indicator and thermometer. The system includes twin pumps that are direct driven variable displacement piston type with load sensing to adjust flow based on hydraulic oil demand in sweeping gear to maximize efficiency and reduce heat.



## SIMPLE, EASY-ACCESS MAINTENANCE

The Broom Bear was designed so that systems are accessible and easy to service. The hydraulic system with o-ring face seal fittings is designed for long life and leak-free operation. Heavy-duty waterproof electrical connectors and color-coded wires have stamped identification for quick location during troubleshooting. A stainless steel toolbox provides additional storage.

## COMMERCIAL CHASSIS/SINGLE ENGINE

A high torque diesel engine is teamed with a Freightliner Business Class or International Durastar chassis to create one of the most powerful and reliable single engine packages in the industry. The straight forward, single engine layout provides greater fuel efficiency and simple maintenance.

## POWER TRAIN

An Allison 3500 RDS transmission, a 10,000 lb (4536 kg) front axle and a 23,000 lb (10433 kg) twin air spring suspension 2-speed rear axle complement the powerful single engine and provide the operator with hours of comfortable ride.



# SUPERIOR MECHANICAL SWEEPER DESIGN

## LARGE VARIABLE HEIGHT DEBRIS HOPPER

The Broom Bear features a variable-height, right side dump hopper with a capacity of 4.5 cubic yard (3.4 cu meters) volumetric. All hopper lift and dump controls are hydraulic and easily operated from in-cab console mounted controls. A 50 degree dump angle allows material to easily slide out.

A unitized, twin-cylinder, double scissors lift rated at 11,000 lbs (4990 kg) unloads material at a minimum of 38 inches (965 mm) and a maximum of 10 feet (3048 mm). Payload capacity is 10,000 lbs (4536 kg) per load. An 11 inch (279 mm) side shift allows material to be unloaded into the center of a truck or container for cleaner dumping. A full hopper can dump and retract in 20 seconds for short intervals and up to 70 seconds at top height.



## SUPERIOR DUST SUPPRESSION

A 360 gallon (1363 L) removable water tank is made of corrosion resistant polyethylene. A 16 foot, 8 inch long (5.1 m) fill hose and water level indicator light located on the control console are standard. Water flow for the side and main brooms is in-cab zone controlled. The self-priming diaphragm pumps (run dry type, 40 psi) provide effective dust control. Three spray nozzles are positioned on each side broom and three on the main broom. Dual water pumps are standard.

## MEMORY SWEEP®

Elgin's exclusive Memory Sweep feature allows the operator to resume all previous sweeper settings, even broom tilt if so equipped, with one touch control. This feature enhances operator productivity and reduces operator fatigue. Memory Sweep incorporates a multiscreen display that indicates engine hours and water tank level as well as system diagnostics. This screen also displays optional features such as broom tilt angle and broom hours.

**MEMORY**  
**SWEEP**





# UNIQUE APPLICATION VERSATILITY

## CONVEYOR FLEXIBILITY

The Broom Bear comes standard with a squeegee type conveyor designed to provide versatile and reliable performance in a wide range of applications including aggregate and granular material pick up of gravel and millings, ideal for road construction contractors as well as general municipal sweeping, trash, leaves, and other organics.

The Broom Bear is also available with a belt conveyor for applications such as highway sweeping and general municipal sweeping where large debris is encountered.

## THE ELGIN SQUEEGEE CONVEYOR

- Chain side-plate constructed from hardened steel for long life and smooth operation.
- Three-piece design for easy service without removing complete assembly.
- Thick, multi-ply rubber-edged flights provides efficient movement of debris into the hopper.
- Unique, interlocking, wavy-plate joint design prevents excessive wear and "thumping" over plate seams.
- Abrasion-resistant steel floor for durability.
- Direct-drive hydraulic motor for optimal power transfer to the conveyor system.



## THE ELGIN BELT CONVEYOR

- Standard new Chevron Belt.
- Full-width angled cleats move more material quickly to hopper for maximum productivity.
- Direct-drive hydraulic motor for optimal power transfer to the conveyor system.
- Improved hopper fill by throwing debris towards center of hopper.
- Heavy-duty poly/nylon belt construction resists stretching and requires fewer adjustments.
- Ribs between cleats enhance effectiveness of moving fine debris into the hopper.



The Broom Bear conveyors are designed to be interchangeable should a customer have different applications throughout the sweep season.



## LOW EMISSIONS – ALTERNATIVE FUEL OPTION

The Elgin Broom Bear is available in a compressed natural gas (CNG) configuration. The Broom Bear single-engine mechanical sweeper is powered by the Cummins Westport ISL G natural gas engine, making it a fully certified EPA/CARB emission compliant street sweeper. Three 3600 psi composite fuel tanks are conveniently packaged in the rear compartment minimizing impact to chassis wheelbase. The Broom Bear has a generous 51 diesel gallon equivalent fuel capacity - providing ample sweeping range.





# OPTIONAL ENHANCEMENTS



## LIFELINER® HOPPER SYSTEM

The LifeLiner® hopper system is a specially designed hopper liner and finish system that greatly improves the life, durability, and functionality of a sweeper hopper.



## IN-CAB SIDE BROOM TILT AND EXTENDED REACH

Allows operator to sweep effectively in variably-pitched gutters. On-the-go pitch adjustment with a simple variable rocker switch that displays proper broom angle. Extended reach allows the side broom to follow curbs and tight cul-de-sacs.

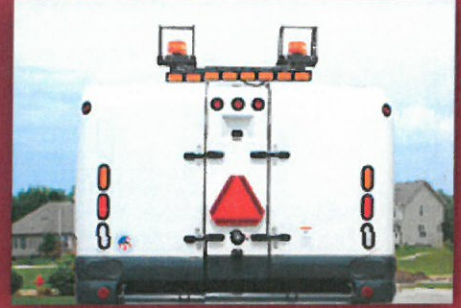

## LIGHTING PACKAGES

The Broom Bear Sweeper can be equipped with a variety of optional lighting packages. Lighting packages are designed for flexibility based on customer requirements and can include strobes, beacons and arrow sticks.

## ADDITIONAL OPTIONS:

- Outside cab, side broom down pressure control
- In-cab, side broom speed control
- 5.4 cubic yard hopper (4.1 cu meter)
- Hydraulic float main broom suspension
- PM10 compliance package
- Functional water control
- Automatic lubrication system
- Front spray bar

## SPECIFICATIONS:

### SWEEP PATH

Main broom only:  
60 in (1524 mm)

Main broom & one side broom:  
90 in (2286 mm)

Main broom and 2 side brooms:  
120 in (3048 mm) up to 144 in (3657 mm)  
with pins in outer points

### HOPPER CAPACITY

Volumetric Capacity: 4.5 yd<sup>3</sup> (3.4 m<sup>3</sup>)

Material volume: 3.3 yd<sup>3</sup> (2.5 m<sup>3</sup>)

### HOPPER DUMPING

Minimum dump height: 38 in (965 mm)

Maximum dump height: 10 ft (3048 mm)

### WATER SPRAY SYSTEM

Tank capacity: 360 gal. (1362 L)

### CHASSIS

Conventional

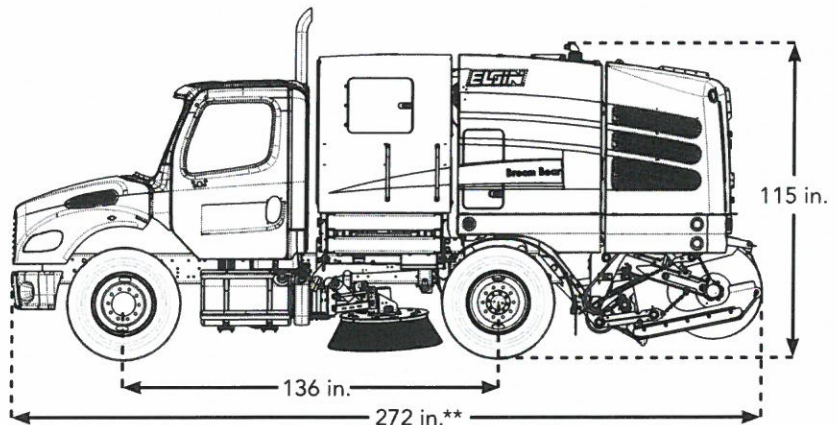

\*Consult factory for warranty details \*\*Transport mode



# ELGIN SWEEPER IS YOUR PARTNER...

## IN THE PLANNING

Instead of one-size-fits-all solutions, we'll work with you to select the sweeping technology that fits your specific needs.



## IN THE STREETS

We're here to help you maintain your Elgin and train your operators to ensure the job is done right.



## INTO THE FUTURE

Our dealers don't just sell you an Elgin; they're available to answer your questions and provide service for the life of the machine.



## WARRANTY

Elgin Sweeper Company backs the Broom Bear sweeper with a one-year limited warranty. The Broom Bear is warranted against defects in material or workmanship for a period of 12 months from the date of delivery to the original purchaser. Optional extended warranty packages are available. Consult your Elgin dealer for complete warranty information.

Your Local Elgin Dealer Is:



[elginsweeper.com](http://elginsweeper.com)

1300 W. Bartlett Road • Elgin, IL 60120 U.S.A.

(847) 741-5370 Phone • (847) 742-3035 Fax

Specifications subject to change without notice. Some items shown may be optional. Elgin® LifeLiner® and Broom Bear® are registered trademarks of Elgin Sweeper Company. Freightliner® is a registered trademark of Daimler Trucks North America, LLC. International® and Durastar® are registered trademarks of Navistar, Inc.

©2015 Elgin Sweeper Company. Effective 7/15 P/N 0705286-E