



---

## Staff Report for Item 17

**To:** Chairman Bryan Green and Historic Architectural Review  
Commission Members

**From:** Kelly Perkins, MHP  
HARC Assistant Planner

**Meeting Date:** June 28, 2016

**Applicant:** Bender and Associates

**Application Number:** H16-03-0044

**Address:** #1415 Newton Street

---

### Description of Work:

Partial demolition of rear portion of house including shed roof and walls.

### Site Facts:

The eyebrow house at 1415 Newton Street is listed as a contributing resource in the survey and was constructed c.1889 according to the survey. By 1962, the structure had the existing one-story addition where the width extends past the contributing eyebrow house. The current shed roof addition does not appear on that map, and therefore is not historic.

### Ordinances and Guidelines Cited in Review:

Sec. 102-217 (2): Demolition of non-historic or non-contributing buildings

Demolitions and Relocations (page 39).

### Staff Analysis

This Certificate of Appropriateness proposes the partial demolition of a non-historic rear addition. Staff believes the demolition will not result in the following items:

- (1) The demolition will not diminish the overall historic character of a district or neighborhood;

- (2) Nor will it destroy the historic relationship between buildings or structures and open space.
- (3) This demolition will not affect the front building façade.
- (4) Staff does not believe elements that are proposed to be demolished will qualify as contributing as set forth in Sec. 1021-62(3).

Therefore this application can be considered for demolition. As the addition is not historic, only one reading is required for demolition.

# APPLICATION

# COMBINATION APPLICATION: FLOODPLAIN, CONSTRUCTION AND HARC

\$50.00 APPLICATION FEE NON-REFUNDABLE



## City of Key West

3140 FLAGLER AVENUE  
KEY WEST, FLORIDA 33040

Phone: 305.809.3956

[www.cityofkeywest-fl.gov](http://www.cityofkeywest-fl.gov)

HARC PERMIT NUMBER <b>16-00300044</b>		BUILDING PERMIT NUMBER	INITIAL & DATE
FLOODPLAIN PERMIT			REVISION #
FLOOD ZONE	PANEL #	ELEV. L. FL.	SUBSTANTIAL IMPROVEMENT ___ YES ___ NO ___ %

ADDRESS OF PROPOSED PROJECT:

1415 Newton Street, Key West, Florida 33040

# OF UNITS

RE # OR ALTERNATE KEY:

Alternate Key # 1024180

NAME ON DEED:

Jones Barbara R/S, Krabill Melissa D.

PHONE NUMBER  
305-293-0022

OWNER'S MAILING ADDRESS:

1415 Newton Street, Key West, Fl 33040

EMAIL  
mitzikrabill@msn.com

CONTRACTOR COMPANY NAME:

PHONE NUMBER

CONTRACTOR'S CONTACT PERSON:

EMAIL

ARCHITECT / ENGINEER'S NAME:

Bert Bender

PHONE NUMBER  
305-296-1347

ARCHITECT / ENGINEER'S ADDRESS:

410 Angela Street, Key West, Fl 33040

EMAIL  
info@benderarchitects.com

HARC: PROJECT LOCATED IN HISTORIC DISTRICT OR IS CONTRIBUTING:  YES \_\_\_ NO (SEE PART C FOR HARC APPLICATION.)

CONTRACT PRICE FOR PROJECT OR ESTIMATED TOTAL FOR MAT'L., LABOR & PROFIT:

100,000.00

FLORIDA STATUTE 837.06: WHOEVER KNOWINGLY MAKES A FALSE STATEMENT IN WRITING AND WITH THE INTENT TO MISLEAD A PUBLIC SERVANT IN THE PERFORMANCE OF HIS OR HER OFFICIAL DUTY SHALL BE GUILTY OF A MISDEMEANOR OF THE SECOND DEGREE PUNISHABLE PER SECTION 775.082 OR 775.083.

PROJECT TYPE: \_\_\_ ONE OR TWO FAMILY \_\_\_ MULTI-FAMILY \_\_\_ COMMERCIAL \_\_\_ NEW  REMODEL  
 \_\_\_ CHANGE OF USE / OCCUPANCY \_\_\_ ADDITION \_\_\_ SIGNAGE \_\_\_ WITHIN FLOOD ZONE \_\_\_  
 DEMOLITION \_\_\_ SITE WORK  INTERIOR  EXTERIOR \_\_\_ AFTER-THE-FACT

DETAILED PROJECT DESCRIPTION INCLUDING QUANTITIES, SQUARE FOOTAGE ETC.,

Demolition of noncontributing rear structure to be replaced by open patio area.

I'VE OBTAINED ALL NECESSARY APPROVALS FROM ASSOCIATIONS, GOVT AGENCIES AND OTHER PARTIES AS APPLICABLE TO COMPLETE THE DESCRIBED PROJECT:

OWNER PRINT NAME:  
**Melissa D. Krabill**

QUALIFIER PRINT NAME:

OWNER SIGNATURE:  
*Melissa D. Krabill*

QUALIFIER SIGNATURE:

Notary Signature as to owner:

Notary Signature as to qualifier:

STATE OF FLORIDA; COUNTY OF MONROE, SWORN TO AND SCRIBED BEFORE ME  
THIS 15th DAY OF June, 2016

STATE OF FLORIDA; COUNTY OF MONROE, SWORN TO AND SCRIBED BEFORE ME  
THIS \_\_\_\_\_ DAY OF \_\_\_\_\_, 20\_\_\_\_

*Daina D. Katubi*



Personally known or produced

as identification.

Personally known or produced

as identification.

1430-2967-01c

**PART B: SUPPLEMENTARY PROJECT DETAILS TO AVOID DELAYS / CALL-BACKS**

PROPERTY STRUCTURES AFFECTED BY PROJECT:  MAIN STRUCTURE  ACCESSORY STRUCTURE  SITE

ACCESSORY STRUCTURES:  GARAGE / CARPORT  DECK  FENCE  OUTBUILDING / SHED

FENCE STRUCTURES:  4 FT.  6 FT. SOLID  6 FT. / TOP 2 FT. 50% OPEN

POOLS:  INGROUND  ABOVE GROUND  SPA / HOT TUB  PRIVATE  PUBLIC  
PUBLIC POOLS REQUIRE BD. OF HEALTH LICENSE APPLICATION AT TIME OF CITY APPLICATION.  
 PUBLIC POOLS REQUIRE BD. OF HEALTH LICENSE PRIOR TO RECEIVING THE CITY CERTIFICATE OF OCCUPANCY.

ROOFING:  NEW  ROOF-OVER  TEAR-OFF  REPAIR  AWNING  
 5 V METAL  ASPLT. SHGLS.  METAL SHGLS.  BLT. UP  TPO  OTHER

FLORIDA ACCESSIBILITY CODE:  20% OF PROJECT FUNDS INVESTED IN ACCESSIBILITY FEATURES.

SIGNAGE:  # OF SINGLE FACE  # OF DOUBLE FACE  REPLACE SKIN ONLY  BOULEVARD ZONE  
 POLE  WALL  PROJECTING  AWNING  HANGING  WINDOW  
 SQ. FT. OF EACH SIGN FACE: \_\_\_\_\_

SUBCONTRACTORS / SPECIALTY CONTRACTORS SUPPLEMENTARY INFORMATION:

MECHANICAL:  DUCTWORK  COMMERCIAL EXH. HOOD  INTAKE / EXH. FANS  LPG TANKS  
 A / C:  COMPLETE SYSTEM  AIR HANDLER  CONDENSER  MINI-SPLIT

ELECTRICAL:  LIGHTING  RECEPTACLES  HOOK-UP EQUIPMENT  LOW VOLTAGE  
 SERVICE:  OVERHEAD  UNDERGROUND  1 PHASE  3 PHASE \_\_\_\_\_ AMPS

PLUMBING:  ONE SEWER LATERAL PER BLDG.  INGROUND GREASE INTCPTRS.  LPG TANKS  
 RESTROOMS:  MEN'S  WOMEN'S  UNISEX  ACCESSIBLE

**PART C: HARC APPLICATION FOR A CERTIFICATE OF APPROPRIATENESS**

APPLICATION FEES: PAINTING SINGLE FAMILY: \$10 STAFF APPROVAL: \$50 COMMISSION REVIEW \$100  
 PLEASE ATTACH APPROPRIATE VARIANCES / RESOLUTIONS FROM HARC, PLANNING BOARD OR TREE COMMISSION.  
 ATTENTION: NO BUILDING PERMITS WILL BE ISSUED PRIOR TO HARC APPROVAL.

PLEASE SEND ELECTRONIC SUBMISSIONS TO: [harc@cityofkeywest-fl.gov](mailto:harc@cityofkeywest-fl.gov)  
 INDICATE TYPE OF CERTIFICATE OF APPROPRIATENESS:  GENERAL  DEMOLITION  SIGN  PAINTING  OTHER

ADDITIONAL INFORMATION: \_\_\_\_\_

PROJECT SPECIFICATIONS: PLEASE PROVIDE PHOTOS OF EXISTING CONDITIONS, PLANS, PRODUCT SAMPLES, TECHNICAL DATA		
ARCHITECTURAL FEATURES TO BE ALTERED:	ORIGINAL MATERIAL:	PROPOSED MATERIAL:
Demo of Rear Addition	Wood siding, flat roof	Open Patio Area, Gable Roof

DEMOLITION: PLEASE FILL OUT THE HARC APPENDIX FOR PROPOSED DEMOLITION.

DEMOLITION OF HISTORIC STRUCTURES IS NOT ENCOURAGED BY THE HISTORIC ARCHITECTURAL REVIEW COMMISSION.

SIGNAGE: (SEE PART B)  BUSINESS SIGN  BRAND SIGN  OTHER: \_\_\_\_\_  
 BUSINESS LICENSE # \_\_\_\_\_ IF FAÇADE MOUNTED, SQ. FT. OF FAÇADE \_\_\_\_\_

Oper: NEWBLD      Trns: BP Drawer 1  
 Date: 5/02/16 50      Receipt no: 18927  
 2016      30044  
 PT      \* BUILDING PERMITS-NEW  
    1.00      \$100.00  
 Trns number:      1317      308870  
 DA CHECK           \$100.00  
 Trns date: 6/11/16      Time: 17:34:17

SIGN SPECIFICATIONS		
SIGN COPY:	PROPOSED MATERIALS:	SIGNS WITH ILLUMINATION:
		TYPE OF LTG.:
		LTG. LINEAL FTG.:
MAX. HGT. OF FONTS:		COLOR AND TOTAL LUMENS:
IF USING LIGHT FIXTURES PLEASE INDICATE HOW MANY:                      INCLUDE SPEC. SHEET WITH LOCATIONS AND COLORS.		

OFFICIAL USE ONLY:                      HARC STAFF OR COMMISSION REVIEW		
<input type="checkbox"/> APPROVED <input type="checkbox"/> NOT APPROVED <input type="checkbox"/> DEFERRED FOR FUTURE CONSIDERATION <input type="checkbox"/> TABLED FOR ADD'L. INFO.		
HARC MEETING DATE:	HARC MEETING DATE:	HARC MEETING DATE:
REASONS OR CONDITIONS:		
STAFF REVIEW COMMENTS:		
HARC PLANNER SIGNATURE AND DATE:		HARC CHAIRPERSON SIGNATURE AND DATE:

**PART D:                      STATE OF FLORIDA OFFICIAL NOTIFICATIONS AND WARNINGS**

FLORIDA STATUTE 713.135: WARNING TO OWNER: YOUR FAILURE TO RECORD A 'NOTICE OF COMMENCEMENT' MAY RESULT IN YOUR PAYING TWICE FOR IMPROVEMENTS TO YOUR PROPERTY. A NOTICE OF COMMENCEMENT MUST BE RECORDED WITH THE COUNTY RECORDER AND A COPY POSTED ON THE JOB SITE BEFORE THE FIRST INSPECTION. IF YOU INTEND TO OBTAIN FINANCING CONSULT WITH YOUR LENDER OR AN ATTORNEY BEFORE RECORDING A NOTICE.

FLORIDA STATUTE 469: ABESTOS ABATEMENT. AS OWNER / CONTRACTOR / AGENT OF RECORD FOR THE CONSTRUCTION APPLIED FOR IN THIS APPLICATION, I AGREE THAT I WILL COMPLY WITH THE PROVISIONS F. S. 469.003 AND TO NOTIFY THE FLORIDA D. E. P. OF MY INTENT TO DEMOLISH / REMOVE ASBESTOS. IN ADDITION TO THE REQUIREMENTS OF THIS PERMIT APPLICATION, THERE MAY BE DEED RESTRICTIONS AND / OR ADDITIONAL RESTRICTIONS APPLICABLE TO THIS PROPERTY THAT MAY BE FOUND IN THE PUBLIC RECORDS OF MONROE COUNTY AND THERE MAY BE ADDITIONAL PERMITS REQUIRED FROM OTHER GOVERNMENT ENTITIES SUCH AS AQUADUCT ATHORITY, FLORIDA DEP OR OTHER STATE AGENCIES; ARMY CORPS OF ENGINEERS OR OTHER FEDERAL AGENCIES.

FEDERAL LAW REQUIRES LEAD PAINT ABATEMENT PER THE STANDARDS OF THE USDEP ON STRUCTURES BUILT PRIOR TO 1978.

OFFICIAL USE ONLY BY PLANS EXAMINER OR CHIEF BUILDING OFFICIAL:				CBO OR PL. EXAM, APPROVAL.:
HARC FEES:	BLDG. FEES:	FIRE MARSHAL FEE:	IMPACT FEES:	
				DATE:

**CITY OF KEY WEST**  
**CERTIFICATE OF APPROPRIATENESS**  
**APPENDIX FOR DEMOLITIONS**  
APPLICATION NUMBER H- \_\_\_\_\_



This document applies only to those properties located within the City of Key West Historic Zoning Districts, properties outside the historic zoning districts which are listed as contributing in the Historic Architectural Survey and or properties listed in the National Register of Historic Places.

Applications must meet or exceed the requirements outlined by the Secretary of the Interior's Standards for Rehabilitation and Guidelines for Rehabilitation and the Key West's Historic Architectural Guidelines. Once submitted, the application shall be reviewed by staff for completeness and scheduled for presentation to the Historic Architectural Review Commission for the next available meeting, unless the demolition request is for a *bona fide* Code Compliance case, in which case staff may review and approve the demolition request. **The applicant must be present at this meeting. Any person that makes changes to an approved Certificate of Appropriateness must submit a new application with such modifications.**

The filing of this application does not ensure approval as submitted. Applications that do not possess the required submittals or documentation will be considered incomplete and will not be reviewed for approval.

**CRITERIA FOR DEMOLITIONS**

Before any Certificate of Appropriateness may be issued for a demolition request, the Historic Architectural Review Commission must find that the following requirements are met (please review and comment on each criterion that applies);

- (1) If the subject of the application is a contributing or historic building or structure, then it should not be demolished unless its condition is irrevocably compromised by extreme deterioration or it does not meet any of the following criteria:

- (a) The existing condition of the building or structure is irrevocably compromised by extreme deterioration.

The structure is a contributing resource. The rear addition that is to be demolished is not contributing.

\_\_\_\_\_  
\_\_\_\_\_

**OR THAT THE BUILDING OR STRUCTURE;**

- (a) Embodies no distinctive characteristics of a type, period, or method of construction of aesthetic or historic significance in the city and is not a significant and distinguishable building entity whose components may lack individual distinction.

The rear addition is not distinctive or historically significant.

\_\_\_\_\_  
\_\_\_\_\_  
\_\_\_\_\_

- (b) Is not specifically associated with events that have made a significant contribution to local, state, or national history.

The rear addition to be demolished is not associated with historically significant events.

\_\_\_\_\_  
\_\_\_\_\_

- (c) Has no significant character, interest, or value as part of the development, heritage, or cultural characteristics of the city, state or nation, and is not associated with the life of a person significant in the past.

The rear addition has no association with this criteria.

---

---

---

- (d) Is not the site of a historic event with a significant effect upon society.

The rear addition has no association with this criteria.

---

---

---

- (e) Does not exemplify the cultural, political, economic, social, or historic heritage of the city.

The rear addition has no association with this criteria.

---

---

---

- (f) Does not portray the environment in an era of history characterized by a distinctive architectural style.

The rear addition has no association with this criteria.

---

---

---

- (g) If a part of or related to a square, park, or other distinctive area, nevertheless should not be developed or preserved according to a plan based on the area's historic, cultural, natural, or architectural motif.

The rear addition has no association with this criteria.

---

---

---

- (h) Does not have a unique location or singular physical characteristic which represents an established and familiar visual feature of its neighborhood or of the city, and does not exemplify the best remaining architectural type in a neighborhood.

The rear addition is not distinctive or historically significant.

---

---

---

- (i) Has not yielded, and is not likely to yield, information important in history.

The rear addition to be demolished is not associated with historically significant events.

---

---



**CITY OF KEY WEST**  
**CERTIFICATE OF APPROPRIATENESS**  
**APPENDIX FOR DEMOLITIONS**  
APPLICATION NUMBER H- \_\_\_\_\_



(2) For a contributing historic or noncontributing building or structure, a complete construction plan for the site is approved by the Historic Architectural Review Commission.

(a) A complete construction plan for the site is included in this application

Yes Number of pages and date on plans 13 pages 10/1/2015  
 No Reason \_\_\_\_\_

The following criteria will also be reviewed by the Historic Architectural Review Commission for proposed demolitions. The Commission shall not issue a Certificate of Appropriateness that would result in the following conditions (please review and comment on each criterion that applies);

(1) Removing buildings or structures that are important in defining the overall historic character of a district or neighborhood so that the character is diminished.

The rear addition has no association with this criteria.  
\_\_\_\_\_  
\_\_\_\_\_

(2) Removing historic buildings or structures and thus destroying the historic relationship between buildings or structures and open space; and

The rear addition has no association with this criteria.  
\_\_\_\_\_  
\_\_\_\_\_

**AND**

(3) Removing an historic building or structure in a complex; or removing a building facade; or removing a significant later addition that is important in defining the historic character of a site or the surrounding district or neighborhood.

The rear addition has no association with this criteria.  
\_\_\_\_\_  
\_\_\_\_\_

(4) Removing buildings or structures that would otherwise qualify as contributing.

The rear addition has no association with this criteria.  
\_\_\_\_\_  
\_\_\_\_\_

**Nothing in this application is intended to alter the authority of the Building Official to condemn for demolition dangerous buildings, as provided in Section 102-218 of the Land Development Regulations and Chapter 14 of the Code of Ordinances.**

*I hereby certify I am the owner of record and that the work shall conform to all applicable laws of this jurisdiction. By receiving a Certificate of Appropriateness, I realize that this project will require a Building Permit, approval **PRIOR to proceeding with the work outlined above** and that there will be a final inspection required under this application. I also understand that any **changes to an approved Certificate of Appropriateness must be submitted for review.***

*Melissa D. Krabill*  
PROPERTY OWNER'S SIGNATURE:

Melissa D. Krabill 6/2/2016  
DATE AND PRINT NAME:

**OFFICE USE ONLY**

**BUILDING DESCRIPTION:**

Contributing    Year built \_\_\_\_\_    Style \_\_\_\_\_    Listed in the NRHP \_\_\_\_\_    Year \_\_\_\_\_  
 Not listed    Year built \_\_\_\_\_    Comments \_\_\_\_\_

Reviewed by Staff on \_\_\_\_\_  
 Notice of hearing posted \_\_\_\_\_  
 First reading meeting date \_\_\_\_\_  
 Second Reading meeting date \_\_\_\_\_  
**TWO YEAR EXPIRATION DATE** \_\_\_\_\_

Staff Comments

# SANBORN MAPS

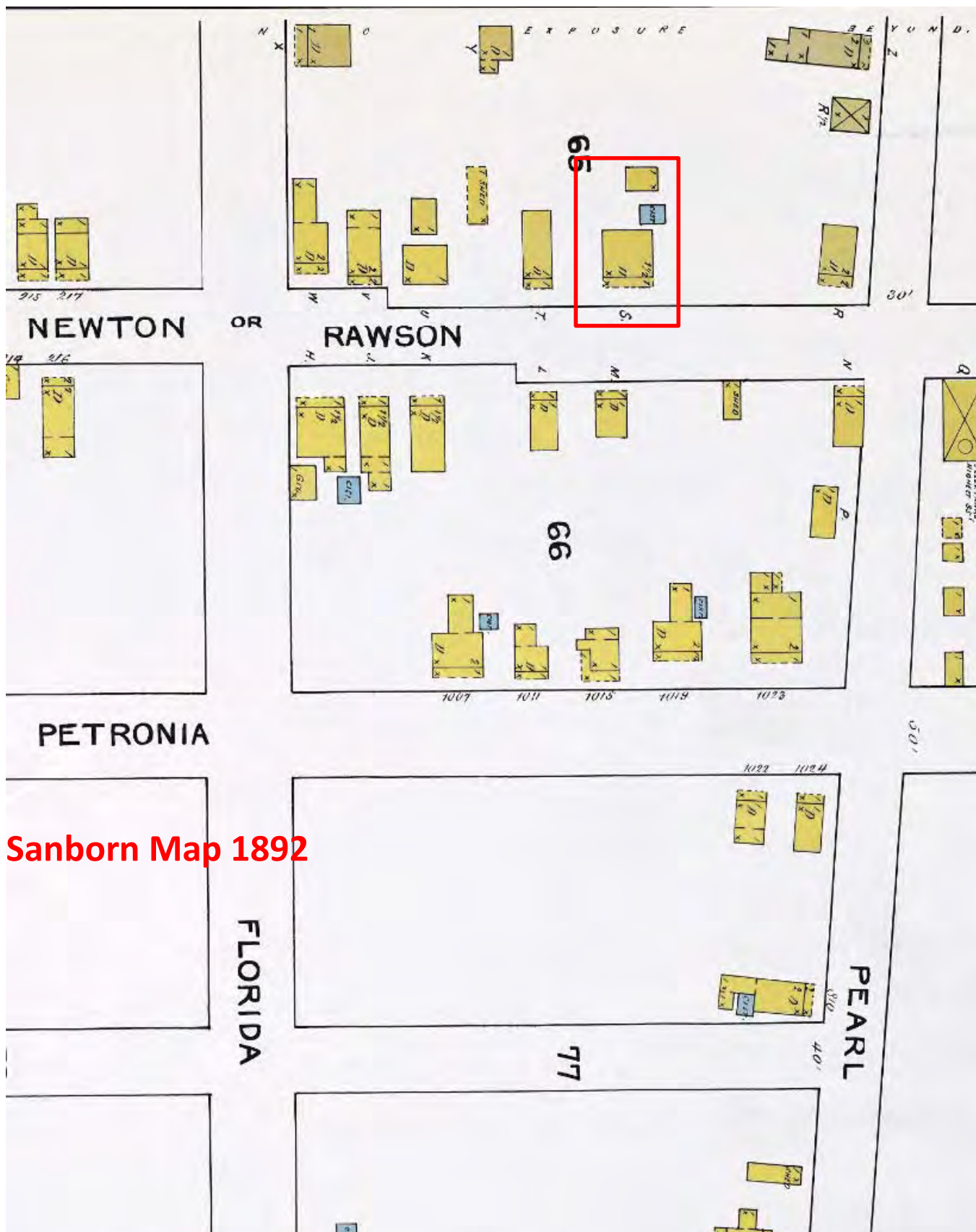

Sanborn Map 1892

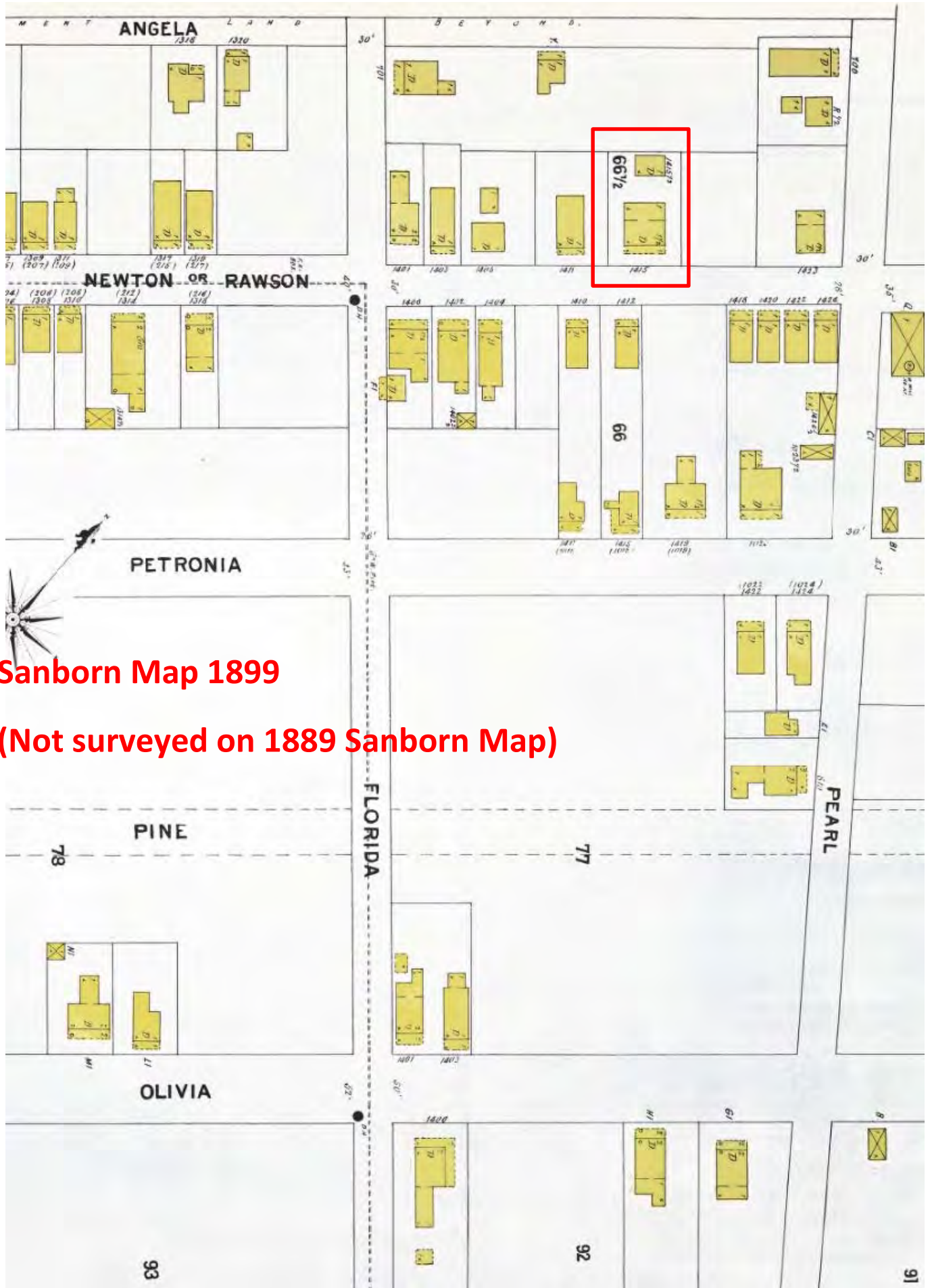

Sanborn Map 1899

(Not surveyed on 1889 Sanborn Map)

1415 NEWTON STREET



Sanborn Map 1912

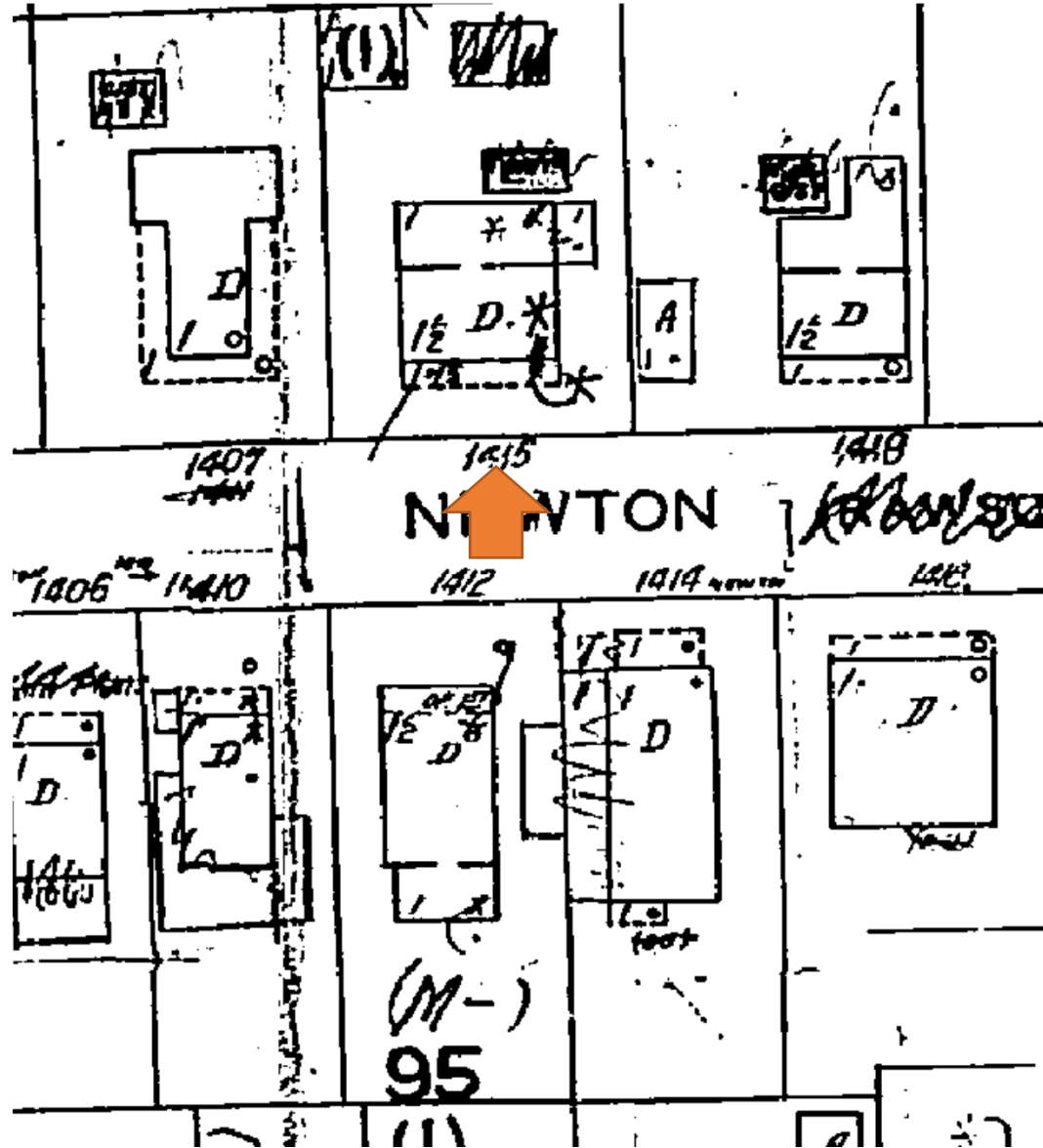

1962 Sanborn Map

# PROJECT PHOTOS





Property Appraiser's Photograph, c.1930s. Monroe County Public Library.



Property Appraiser's Photograph, c.1965. Monroe County Public Library.

1415 NEWTON STREET

Front (Pine Street) façade. No work on the main building.



West facade. No work on this side of the building. For Reference only.



1415 NEWTON STREET

Rear façade of the house.



East façade of the house.



1415 NEWTON STREET

East façade of the building



Existing Garage (front view). No work this building; for reference only.



# PROPOSED DESIGN

# KRABILL AND JONES RESIDENCE

## 1415 NEWTON STREET

### KEY WEST FLORIDA

KRABILL AND JONES RESIDENCE  
1415 NEWTON STREET  
KEY WEST, FLORIDA, 33040

SITE MAP - KEY WEST	PROJECT DIRECTORY	GENERAL NOTES	SHEET INDEX																																																																																																													
<p><b>SITE LOCATION</b> KRABILL &amp; JONES RESIDENCE - 1415 NEWTON STREET</p> <p>Not to Scale</p>	<p><b>PROJECT DIRECTORY</b></p> <p>KRABILL AND JONES RESIDENCE ARCHITECT'S PROJECT No.: 1522</p> <p>OWNER: KRABILL AND JONES Address: 1415 NEWTON AVE KEY WEST, FL 33040 Tel: 305.</p> <p>Representative: MITZ KRABILL</p> <p>ARCHITECT: BENDER &amp; ASSOCIATES ARCHITECTS, P.A. Address: 410 Angela Street, Key West, FL 33040 Tel: (305) 296-1347 Fax: (305) 296-2727 E-mail: info@benderarchitects.com Project Architect: Bert L. Bender (Principal-in-Charge)</p>	<p><b>GENERAL NOTES</b></p> <ol style="list-style-type: none"> <li>All work shall comply with the Florida Building Code, latest edition, and all applicable laws, codes and ordinances of the City, County, and the State of Florida in the City of Key West, applicable Codes forming the basis of this design and compliance requirements for the Contractor include:              FLORIDA BUILDING CODE - Building 2014 EDITION              FLORIDA BUILDING CODE - Existing 2014 EDITION              FLORIDA BUILDING CODE - Residential 2014 EDITION              FLORIDA BUILDING CODE - Plumbing 2014              FLORIDA BUILDING CODE - Fuel Gas 2014 EDITION              FLORIDA BUILDING CODE - Mechanical 2014 EDITION              NATIONAL ELECTRICAL CODE 2008 EDITION              NFPA 101 LIFE SAFETY CODE w/ Florida Modifications              2006 EDITION FLORIDA FIRE PREVENTION CODE 2007 EDITION              NFPA 1 2006 EDITION              This project is designed in accordance with A.S.C.E. 7-10 to resist wind loads of 180 mph (gusts).</li> <li>Prior to submitting a bid, verify all existing conditions and dimensions on the jobsite, and also after award, but prior to the start of construction.</li> <li>Contours and/or existing grades shown are approximate. Verify with field conditions. Final grading shall provide gradual slopes and grades. Slope all grades away from the building. Planting areas shall be graded with soil suitable for planting. Rock and debris will not be allowed.</li> <li>Where discrepancies between drawings, specifications, and code requirements occur, adhere to the most stringent requirement.</li> <li>Dimensions shall take precedence over scale.</li> <li>All new utilities shall be underground.</li> <li>Drawings and specifications are complementary. Refer to all sheets of drawings and applicable sections of the specifications for interfaces of work with related trades.</li> <li>After completion of construction remove all debris and construction equipment. Restore site to original condition.</li> <li>Notify owner of any possible artifacts uncovered during site grading and throughout the course of construction.</li> <li>Furnish a receptacle on site to contain construction debris and maintain the site in an orderly manner to ensure public safety and prevent blowing debris.</li> <li>Comply with all requirements for selective demolition as specified, shown on the Demolition Plan, or called for in the selective Demolition Notes.</li> </ol> <p>6161-16.003 Use of Seal: The personal seal, signature and date of the architect or interior designer shall appear on all architectural or interior design documents to be filed for public record and shall be construed to obligate his partners or his corporation. A corporate seal alone is insufficient. Documents shall be signed personally and sealed by the responsible architect or interior designer. Final official record documents (not tracings, etc.) shall be so signed. The signing and sealing of the specification index sheets shall be considered adequate. All drawing sheets and pages shall be so signed and sealed. An architect or interior designer shall not affix, or permit to be affixed, his seal or name to any plan, specifications, drawings, or other related document which was not prepared by him or under his responsible supervising control as provided in Rule Chapter 61G1-23, F.A.C. An architect or interior designer shall not use his seal or do any other act as an architect or interior designer unless holding at the time a certificate of registration and all required renewals thereof.</p> <p>Specific Authority 481.2055, 481.221 FS. Law Implemented 481.221, 481.225(1)(e), (g), (i), (j), 481.225(1)(g), (h), (i) FS. History-New 12-23-79, Formerly 21B-16.03, Amended 7-27-89, Formerly 21B-16.003, Amended 11-21-94, 4-18-00.</p>	<p><b>SHEET INDEX</b></p> <p>A.0 SITE LOCATION MAP, SHEET INDEX, GENERAL NOTES, FLORIDA ADMINISTRATIVE CODE, SYMBOLS LEGEND</p> <p><b>ARCHITECTURAL:</b></p> <p>A1.0 EXISTING SITE PLAN          A2.0 DEMO FLOOR PLAN          A3.0 FOUNDATION FLOOR FRAMING, CEILING FRAMING, ROOF FRAMING PLAN          A4.0 PROPOSED FLOOR PLAN AND SCHEDULES</p> <p><b>A5.0 SECTION</b>          A6.0 PROPOSED EXTERIOR ELEVATIONS          A7.0 INTERIOR ELEVATIONS</p> <p><b>A8.0 DETAILS: FOUNDATION, DOORS AND WINDOWS</b>          A9.0 ELECTRICAL PLAN          A9.1 MECHANICAL AND PLUMBING PLAN AND NOTES          A10 STRUCTURAL NOTES</p> <p>SP1 SPECIFICATIONS</p>																																																																																																													
<p><b>ABBREVIATIONS</b></p> <table border="0"> <tr> <td>AB ANCHOR BOLT</td> <td>MIN MINIMUM</td> <td>NTS NOT TO SCALE</td> </tr> <tr> <td>ABC AGGREGATE BASE COURSE</td> <td>OA OVERALL</td> <td>OC ON CENTER</td> </tr> <tr> <td>AVC AIR CONDITIONING</td> <td>OD OUTSIDE DIAMETER</td> <td>PCF POUNDS PER CUBIC FOOT</td> </tr> <tr> <td>BLKG BLOCKING</td> <td>PL PROPETRY LINE</td> <td>PLAM PLASTIC LAMINATE</td> </tr> <tr> <td>BUR BILT UP ROOF</td> <td>PLF POUNDS PER LINEAL FOOT</td> <td>PNL PANEL</td> </tr> <tr> <td>CAB CABINET</td> <td>PT CCA PRESSURE TREATED</td> <td>PT POINT</td> </tr> <tr> <td>CER CERAMIC</td> <td>PVC POLYVINYLCHLORIDE</td> <td>R RADIUS (OR) RISER</td> </tr> <tr> <td>CL CENTER LINE</td> <td>R/R RETURN AIR</td> <td>R/A STEEL REINF. BAR</td> </tr> <tr> <td>CLG CEILING</td> <td>REFR. REFRIGERATOR</td> <td>REFR. REFRIGERATOR</td> </tr> <tr> <td>CMU CONCRETE MASONRY UNIT</td> <td>SF SQUARE FOOT (FEET)</td> <td>SS STAINLESS STEEL</td> </tr> <tr> <td>COL COLUMN</td> <td>SPEC SPECIFICATION</td> <td>T TREAD(S)</td> </tr> <tr> <td>CONC CONCRETE</td> <td>TYP TYPICAL</td> <td>UNO UNLESS NOTED OTHERWISE</td> </tr> <tr> <td>DBL DOUBLE</td> <td>VCT VINYL COMPOSITION TILE</td> <td>VERT VERTICAL</td> </tr> <tr> <td>DIAG DIAGONAL</td> <td>WD WOOD</td> <td>WHD WELDED WIRE FABRIC</td> </tr> <tr> <td>DS DOWNSPOUT</td> <td>W/F WATER HEATER</td> <td>W/WO WITHOUT</td> </tr> <tr> <td>DTL DETAIL</td> <td></td> <td></td> </tr> <tr> <td>DNR DRAINER</td> <td></td> <td></td> </tr> <tr> <td>EJ EXPANSION JOINT</td> <td></td> <td></td> </tr> <tr> <td>EL ELEVATION</td> <td></td> <td></td> </tr> <tr> <td>ELEC ELECTRIC</td> <td></td> <td></td> </tr> <tr> <td>EQ EQUAL</td> <td></td> <td></td> </tr> <tr> <td>EXH EXHAUST</td> <td></td> <td></td> </tr> <tr> <td>FV FIELD VERIFY</td> <td></td> <td></td> </tr> <tr> <td>GALV GALVANIZED</td> <td></td> <td></td> </tr> <tr> <td>GI GALVANIZED IRON</td> <td></td> <td></td> </tr> <tr> <td>HORZ HORIZONTAL</td> <td></td> <td></td> </tr> <tr> <td>HDN HARDWARE</td> <td></td> <td></td> </tr> <tr> <td>HVAC HEATING VENTILATING &amp; AIR CONDITIONING</td> <td></td> <td></td> </tr> <tr> <td>FOC FACE OF CONCRETE</td> <td></td> <td></td> </tr> <tr> <td>FOS FACE OF STUD</td> <td></td> <td></td> </tr> <tr> <td>FIN FINISH</td> <td></td> <td></td> </tr> <tr> <td>FE FIRE EXTINGUISHER</td> <td></td> <td></td> </tr> <tr> <td>FND FOUNDATION</td> <td></td> <td></td> </tr> <tr> <td>FTG FOOTING</td> <td></td> <td></td> </tr> <tr> <td>ID INSIDE DIAMETER</td> <td></td> <td></td> </tr> <tr> <td>MAX MAXIMUM</td> <td></td> <td></td> </tr> </table>	AB ANCHOR BOLT	MIN MINIMUM	NTS NOT TO SCALE	ABC AGGREGATE BASE COURSE	OA OVERALL	OC ON CENTER	AVC AIR CONDITIONING	OD OUTSIDE DIAMETER	PCF POUNDS PER CUBIC FOOT	BLKG BLOCKING	PL PROPETRY LINE	PLAM PLASTIC LAMINATE	BUR BILT UP ROOF	PLF POUNDS PER LINEAL FOOT	PNL PANEL	CAB CABINET	PT CCA PRESSURE TREATED	PT POINT	CER CERAMIC	PVC POLYVINYLCHLORIDE	R RADIUS (OR) RISER	CL CENTER LINE	R/R RETURN AIR	R/A STEEL REINF. BAR	CLG CEILING	REFR. REFRIGERATOR	REFR. REFRIGERATOR	CMU CONCRETE MASONRY UNIT	SF SQUARE FOOT (FEET)	SS STAINLESS STEEL	COL COLUMN	SPEC SPECIFICATION	T TREAD(S)	CONC CONCRETE	TYP TYPICAL	UNO UNLESS NOTED OTHERWISE	DBL DOUBLE	VCT VINYL COMPOSITION TILE	VERT VERTICAL	DIAG DIAGONAL	WD WOOD	WHD WELDED WIRE FABRIC	DS DOWNSPOUT	W/F WATER HEATER	W/WO WITHOUT	DTL DETAIL			DNR DRAINER			EJ EXPANSION JOINT			EL ELEVATION			ELEC ELECTRIC			EQ EQUAL			EXH EXHAUST			FV FIELD VERIFY			GALV GALVANIZED			GI GALVANIZED IRON			HORZ HORIZONTAL			HDN HARDWARE			HVAC HEATING VENTILATING & AIR CONDITIONING			FOC FACE OF CONCRETE			FOS FACE OF STUD			FIN FINISH			FE FIRE EXTINGUISHER			FND FOUNDATION			FTG FOOTING			ID INSIDE DIAMETER			MAX MAXIMUM			<p><b>SYMBOLS LEGEND</b></p> <p>TRUE NORTH PROJECT NORTH</p> <p>FLOOR PLANS, ETC. (THROUGHOUT DWGS.) SITE PLANS (ONCE ONLY)</p> <p><b>NORTH ARROWS</b></p> <p>LETTER FOR SECT. DESIGNATION SHEET WHERE SECTION IS SHOWN</p> <p><b>BUILDING SECTION</b></p> <p>LETTER FOR SECT. DESIGNATION SHEET WHERE SECTION IS SHOWN</p> <p><b>WALL SECTION</b></p> <p>NUMBER FOR DETAIL DESIGNATION SHEET WHERE DETAIL IS SHOWN</p> <p><b>CUT DETAIL INDICATOR</b></p> <p>NUMBER FOR DETAIL DESIGNATION SHEET WHERE DETAIL IS SHOWN</p> <p><b>BLOWN-UP DETAIL INDICATOR</b> (PERTAINS TO DETAIL PLAN INDICATOR ON SMALLER SCALE PLAN)</p>	<p><b>CROSS SECTION</b> 1/4" = 1'-0" DRAWING SCALE</p> <p><b>SECTION &amp; DETAIL DRWG. TITLES</b></p> <p>POCHE ONLY WHERE ELEVATIONS ARE INDICATED</p> <p>SHT. A-B INDICATES # OF ELEVATION</p> <p><b>WALL ELEVATION INDICATOR</b> (SHOWN WITHIN ROOM ON PLAN)</p> <p>FIRST # INDICATES FLOOR 206</p> <p><b>ROOM NUMBER INDICATOR</b> (SHOWN BESIDE OR UNDER ROOM NAME)</p> <p>NUMBERS 23 LETTERS A</p> <p><b>DOOR OPENING INDICATOR</b> (EACH OPENING SCHEDULED SEPARATELY)</p> <p>LETTERS PE</p> <p><b>WINDOW INDICATOR</b> (EACH WINDOW TYPE &amp; SIZE SCHEDULED)</p> <p><b>PARTITION/WALL TYPE INDICATOR</b> (COMMERCIAL &amp; INSTITUTIONAL PROJECTS)</p>	<p><b>MATERIAL DESIGNATIONS</b></p> <p>CONCRETE MASONRY UNITS IN PLAN CONC., STUCCO, PLASTER IN ELEV.;POURED CONC. IN PLAN METAL IN ELEVATION METAL IN SECTION FINISH WOOD IN ELEV. &amp; IN SECTION DIMENSION LUMBER IN SECTION (CONTINUOUS) WOOD BLOCKING IN SECTION (DISCONTINUOUS) GYPSUM WALL BOARD IN SECTION (LARGE SCALE) EARTH, NATURAL SUBSTRATE GRAVEL, AGGREGATE BASE COURSE, FILL FIBERGLASS BATT INSULATION RIGID INSULATION</p> <p><b>PARTITIONS &amp; WALLS</b></p> <p>CONCRETE MASONRY UNITS POURED CONCRETE WOOD FRAME METAL STUDS EXISTING CONSTRUCTION TO REMAIN EXISTING CONSTRUCTION TO BE DEMOLISHED</p>	<p><b>DESCRIPTION OF WORK:</b></p> <p>DEMOLITION OF NONCONTRIBUTING REAR STRUCTURE, TO BE REPLACED WITH OPEN PATIO AREA. RENOVATION OF MASTER BATHROOM.</p>
AB ANCHOR BOLT	MIN MINIMUM	NTS NOT TO SCALE																																																																																																														
ABC AGGREGATE BASE COURSE	OA OVERALL	OC ON CENTER																																																																																																														
AVC AIR CONDITIONING	OD OUTSIDE DIAMETER	PCF POUNDS PER CUBIC FOOT																																																																																																														
BLKG BLOCKING	PL PROPETRY LINE	PLAM PLASTIC LAMINATE																																																																																																														
BUR BILT UP ROOF	PLF POUNDS PER LINEAL FOOT	PNL PANEL																																																																																																														
CAB CABINET	PT CCA PRESSURE TREATED	PT POINT																																																																																																														
CER CERAMIC	PVC POLYVINYLCHLORIDE	R RADIUS (OR) RISER																																																																																																														
CL CENTER LINE	R/R RETURN AIR	R/A STEEL REINF. BAR																																																																																																														
CLG CEILING	REFR. REFRIGERATOR	REFR. REFRIGERATOR																																																																																																														
CMU CONCRETE MASONRY UNIT	SF SQUARE FOOT (FEET)	SS STAINLESS STEEL																																																																																																														
COL COLUMN	SPEC SPECIFICATION	T TREAD(S)																																																																																																														
CONC CONCRETE	TYP TYPICAL	UNO UNLESS NOTED OTHERWISE																																																																																																														
DBL DOUBLE	VCT VINYL COMPOSITION TILE	VERT VERTICAL																																																																																																														
DIAG DIAGONAL	WD WOOD	WHD WELDED WIRE FABRIC																																																																																																														
DS DOWNSPOUT	W/F WATER HEATER	W/WO WITHOUT																																																																																																														
DTL DETAIL																																																																																																																
DNR DRAINER																																																																																																																
EJ EXPANSION JOINT																																																																																																																
EL ELEVATION																																																																																																																
ELEC ELECTRIC																																																																																																																
EQ EQUAL																																																																																																																
EXH EXHAUST																																																																																																																
FV FIELD VERIFY																																																																																																																
GALV GALVANIZED																																																																																																																
GI GALVANIZED IRON																																																																																																																
HORZ HORIZONTAL																																																																																																																
HDN HARDWARE																																																																																																																
HVAC HEATING VENTILATING & AIR CONDITIONING																																																																																																																
FOC FACE OF CONCRETE																																																																																																																
FOS FACE OF STUD																																																																																																																
FIN FINISH																																																																																																																
FE FIRE EXTINGUISHER																																																																																																																
FND FOUNDATION																																																																																																																
FTG FOOTING																																																																																																																
ID INSIDE DIAMETER																																																																																																																
MAX MAXIMUM																																																																																																																

410 Angela Street  
Key West, Florida 33040  
Telephone (305) 296-1347  
Facsimile (305) 296-2727  
Florida License AAC002022

Bender & Associates  
ARCHITECTS  
p.a.

Project No: 1526

SITE MAP  
PROJECT DIRECTORY  
GENERAL NOTES  
ABBREVIATIONS  
SHEET INDEX  
SYMBOL LEGEND

Date: 10/01/15

**A.0**  
1 OF 13

**PROJECT STATISTICS - 1415 NEWTON STREET**

LOT DESCRIPTION: SEE SURVEY.

LOT SIZE: 55'x84.12' + 4.2'x79.97'  
LOT AREA: 4855 S.F.

PROPOSED BLDG COVERAGE AREA:  
ENCLOSED AREA: 1,561 S.F.  
ROOFED PORCHES: 329 S.F.  
TOTAL: 1,890 S.F.

FEMA FLOOD ZONE: 'X'  
FINISH FLOOR ELEVATION: T.B.D. (21" ABOVE GRADE IN ZONE 'X')  
ZONING DESIGNATION: HMDR (HISTORIC MEDIUM DENSITY RESIDENTIAL)  
LOT AREA: 4,855 S.F.  
BUILDING CONDITIONED AREA: 1,916 S.F.

**SETBACKS:**

	REQUIRED/ALLOWED	EXISTING: (NO CHANGE)	PROPOSED: (NO CHANGE)
BUILDING HEIGHT:	30' MAXIMUM	(NO CHANGE)	(NO CHANGE)
FRONT SETBACK:	10' MINIMUM	1'-2" (NO CHANGE)	1'-2" (NO CHANGE)
SIDE SETBACK:	5' MINIMUM	1'-9" (NO CHANGE)	1'-9" (NO CHANGE)
REAR SETBACK:	15' MINIMUM	9'-5" (NO CHANGE)	9'-5" (NO CHANGE)
IMPERVIOUS SURFACE:	MAX. 60% OF LOT AREA		
BUILDING COVERAGE:	MAX. 40% OF LOT AREA	4,855 S.F. / 1,916 S.F. = 39.5%	4,855 S.F. / 1,890 S.F. = 38.9%
F.A.R.:	N/A - RESIDENTIAL	N/A - RESIDENTIAL	N/A - RESIDENTIAL

**1415 NEWTON STREET  
IMPERVIOUS SURFACE ANALYSIS:**

	EXISTING	PROPOSED
LOT AREA	4,854 S.F.	4,854 S.F.
MAIN RESIDENCE	1,495 S.F.	1,328 S.F.
PORCHES	198 S.F.	198 S.F.
POOLS	204 S.F.	204 S.F.
ACCESSORY STRUCTURES	233 S.F.	233 S.F.
CONC. SLABS	1,361 S.F.	1,361 S.F.
A/C, GAS, POOL SPA EQUIP PADS	45 S.F.	45 S.F.
TOTALS:	3,536 S.F.	3,368 S.F.
% IMPERVIOUS (60% ALLOWED)	72.8%	69.4%

**NOTE:**

IMPERVIOUS AREA REDUCED FROM EXISTING. SHALES NOT REQUIRED.

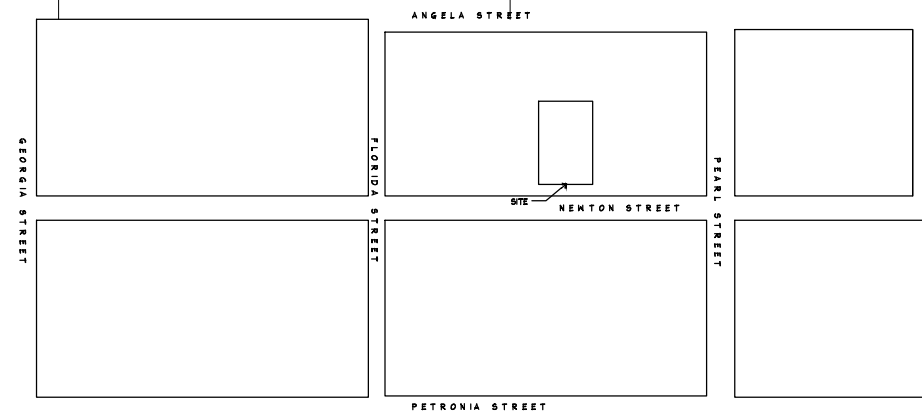

**3 LOCATION MAP**  
AI.0 SCALE: N.T.S.

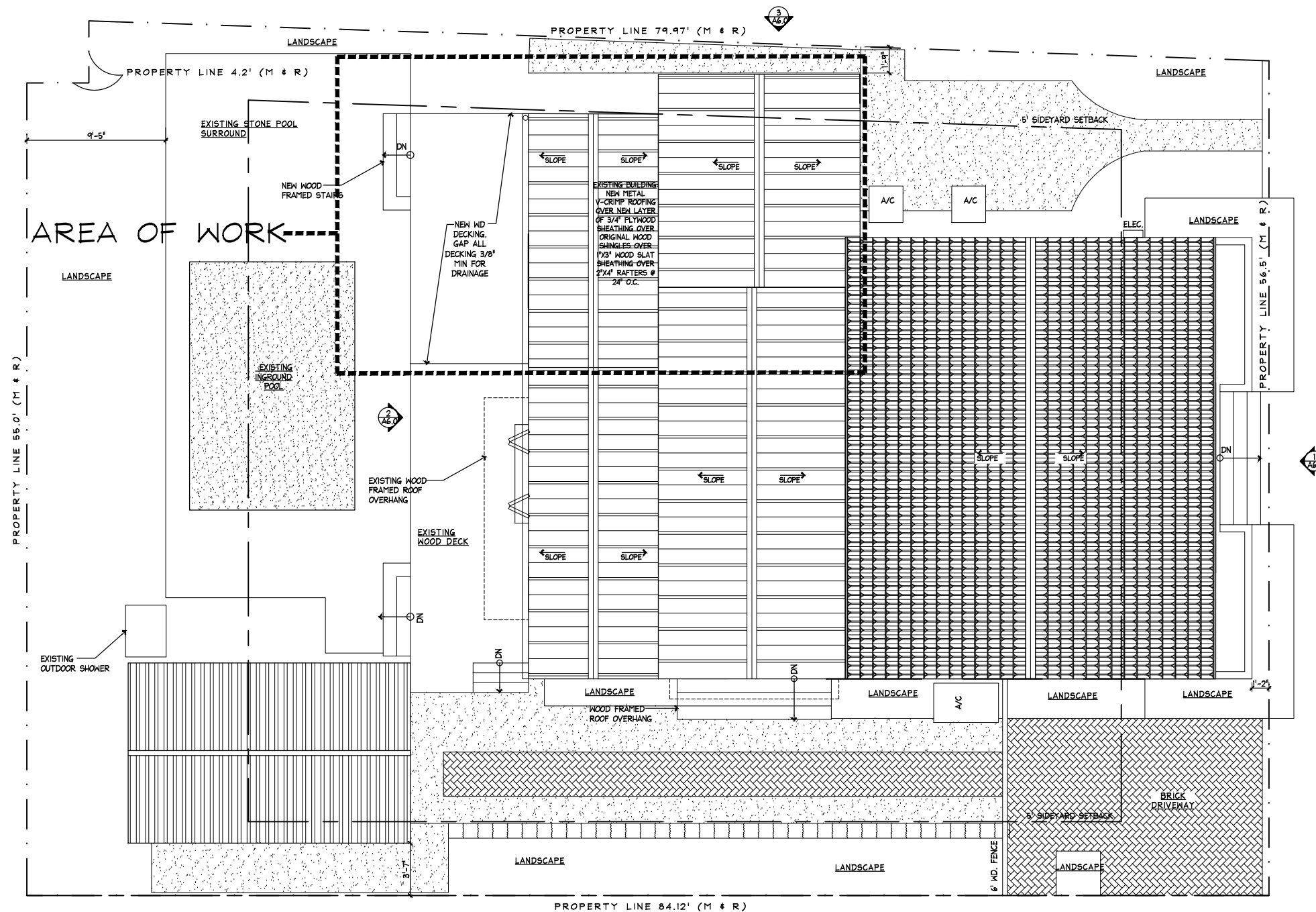
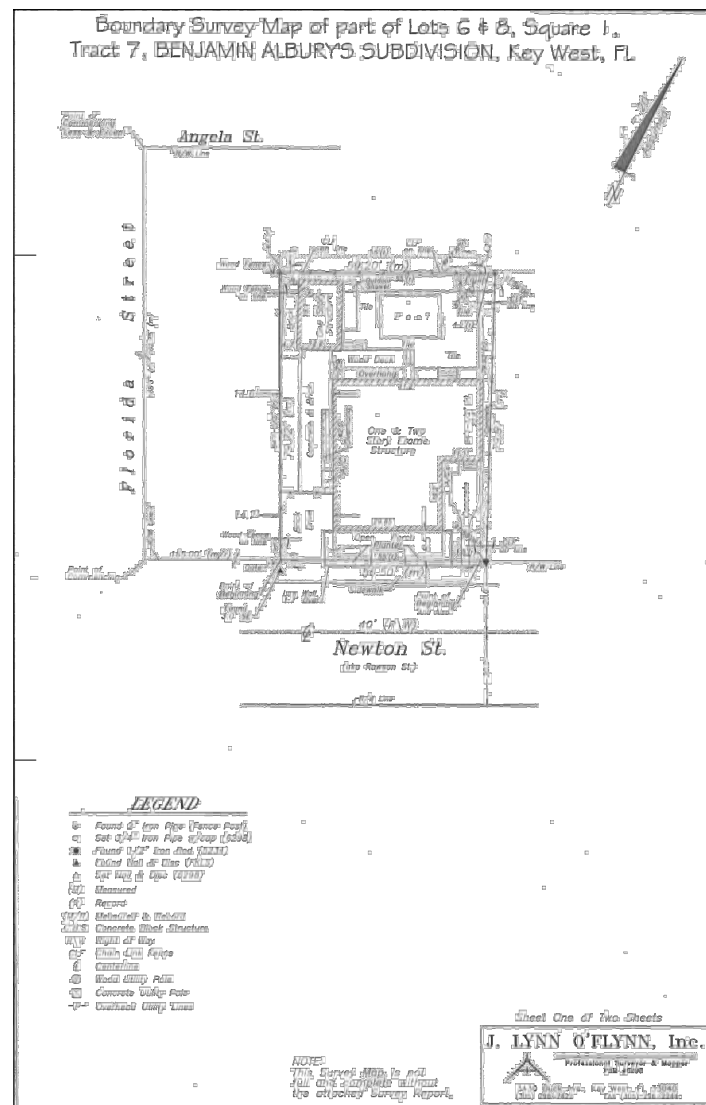

**1 PROPOSED SITE PLAN**  
AI.0 SCALE: 1/4"=1'-0"

**2 SURVEY**  
AI.0 SCALE: N.T.S.

**KRABILL AND JONES RESIDENCE**  
1415 NEWTON STREET  
KEY WEST, FLORIDA, 33040

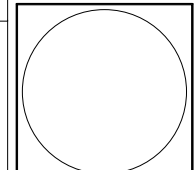

410 Angela Street  
Key West, Florida 33040  
Telephone (305) 296-1347  
Facsimile (305) 296-2727  
Florida License AAC002022

**Bender & Associates**  
**ARCHITECTS**  
p.a.

Project No: 1526  
PROPOSED SITEPLAN  
Date: 10/01/15

**A1.0**  
2 OF 13



**DEMOLITION NOTES**

1. Prior to submitting a bid, verify all existing conditions and dimensions on the job site, and also after award, but prior to the start of construction.
2. All demolished material shall become the property of the contractor, unless specifically noted otherwise, and shall be properly removed from the site. Comply with all applicable laws, codes and regulations of governmental agencies having jurisdiction over the project.
3. All costs of demolition including permit fees, disposal fees, etc. are the responsibility of the Contractor.
4. It is the Contractor's responsibility to be aware of and to conform with all applicable demolition and disposal codes, safety requirements, and environmental protection regulations of any governmental body having jurisdiction over the work.
5. Provide safety barricades as required to protect the safety of the general public and workers connected with the project.
6. Provide bracing and shoring as required to protect the safety of the general public and workers connected with the project.
7. Demolished material classified as clean fill may be distributed on site when specifically approved by the Architect in advance.

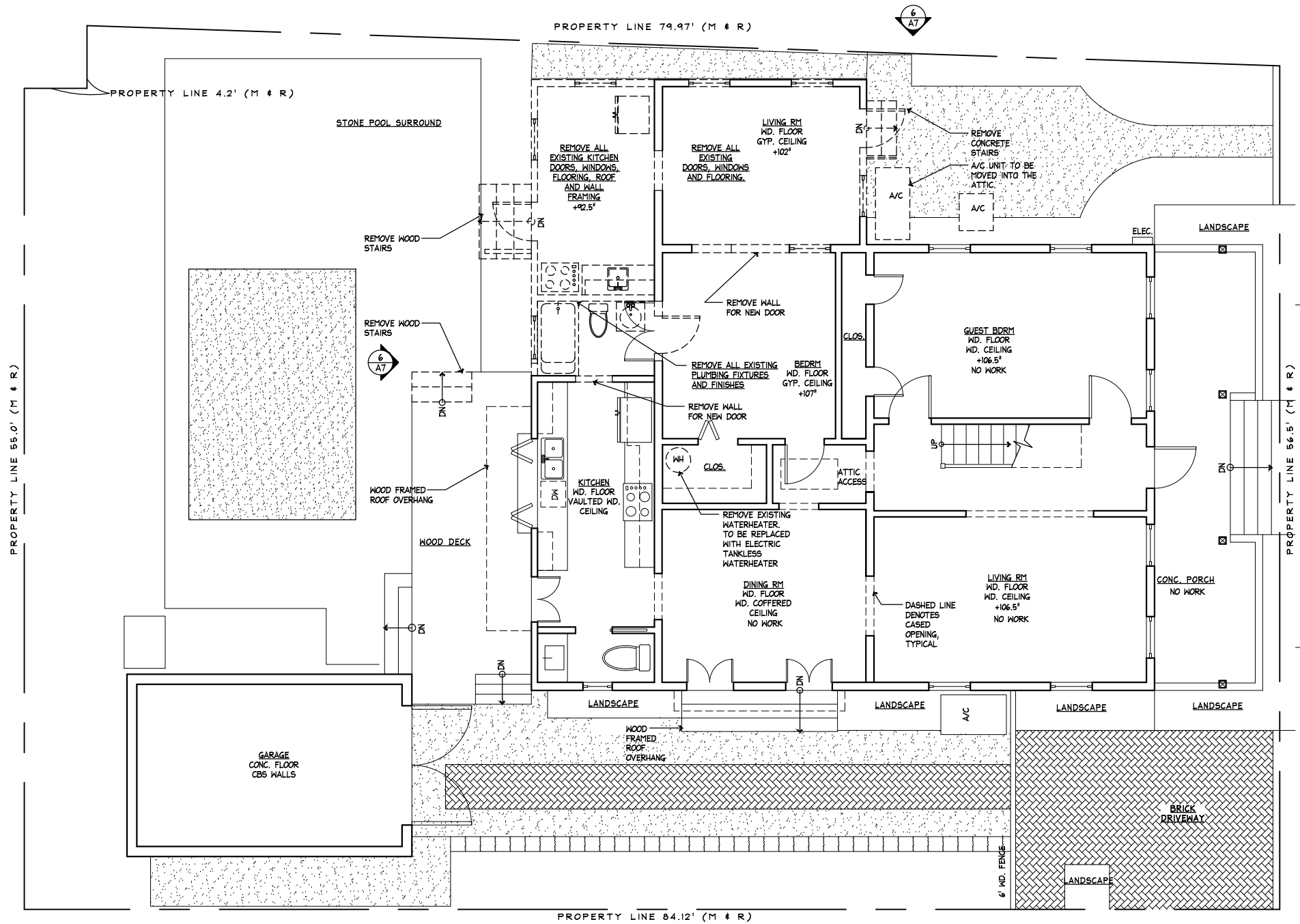

**KRABILL AND JONES RESIDENCE**  
 1415 NEWTON STREET  
 KEY WEST, FLORIDA, 33040

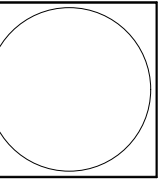

410 Angela Street  
 Key West, Florida 33040  
 Telephone (305) 296-1347  
 Facsimile (305) 296-2727  
 Florida License AAC002022

*Bender & Associates*  
**ARCHITECTS** p.a.

Project No: 1526

FIRST FLOOR DEMOLITION PLAN

Date: 10/01/15

**A1.1**

**FIRST FLOOR DEMOLITION PLAN**  
 A1.1 SCALE: 1/4"=1'-0"

**FOUNDATION & CONCRETE NOTES**

- The Contractor shall have the option of substituting solid concrete piers and/or foundations for concrete filled masonry piers or foundation walls.
- Minimum concrete strength shall be 4000 p.s.i. unless otherwise specified in these documents.
- Comply with "General Structural Notes" included elsewhere in these documents.
- Concrete protection for reinforcement:
  - The reinforcement of footings and other principal structural members in which the concrete is deposited against the ground shall have not less than 3 in. of concrete between it and the ground contact surface. If concrete surfaces after removal of the forms are to be exposed to the weather or be in contact with the ground, the reinforcement shall be protected with not less than 2" of concrete or other approved material.
  - The concrete protective covering for any reinforcement at surfaces not exposed directly to the ground or weather shall be not less than 3/4" for slabs and walls and not less than 1 1/2" for beams and girders. In concrete joint floors in which the clear distance between joists is not more than 30 in., the protection of reinforcement shall be at least 3/4".
  - Column spirals or ties shall be protected everywhere by a covering of concrete cast monolithically with the core, for which the thickness shall be not less than 1 1/2", nor less than 1 1/2" times the maximum size of the coarse aggregate.
  - Concrete protection for reinforcement shall in all cases be at least equal to the diameter of bars, except for concrete slabs and joists in (2.).
  - In extremely corrosive atmospheres or other severe exposures, the amount of protection shall be suitably increased. In the Florida Keys, increase concrete coverage by 50% of specified tolerances and in no case less than 2 inches.

**GENERAL FRAMING NOTES**

- Comply with "General Structural Notes" included elsewhere in these documents.
- Where used joists/beams etc. frame into other members, and ledgers are not provided, install Simpson "LH" series joist hangers.
- When installing into ACO pressure treated lumber, Contractor has the option of providing EITHER stainless steel joist fasteners and stainless steel fasteners, OR Simpson 2044 (C65) galvanized joist hangers with hot-dip galvanized fasteners. Contractor shall not mix stainless steel with hot-dip galvanized.
- Provide hot dip (ZMAX) galvanized hurricane clips at all rafters at bearing locations. Provide 2 x 4 minimum collar ties between rafters at ridges in attic spaces, light to ridge. Nail to each rafter with (3) 16d nails.
- Provide solid blocking at midspan of all joists and rafters for spans of 8' and over. Use 3 rows of blocking where spans exceed 16 feet.
- Firestopping shall be provided in all walls and partitions to cut off all concealed draft openings both horizontal and vertical and to form a fire barrier between floors and between the upper floor and the roof space. Firestopping shall be installed in wood frame construction in the following locations:
  - In concealed space of stud walls and partitions including furrowed spaces at ceiling and floor levels.
  - At all interconnections between concealed vertical and horizontal spaces such as occur at soffits, drop ceilings, cave ceilings, etc.
  - In concealed spaces between stair stringers at the top and bottom of the run.
  - In concealed spaces created by an assembly of floor joists, firestopping shall be provided for the full depth of the joists at the ends and over the supports.
- Firestopping shall consist of two (2) inch nominal lumber, or two (2) thicknesses of one (1) inch nominal lumber with broken lap joints, or one (1) thickness of three-fourths (3/4) inch plywood, with joints lapped by three-fourths (3/4) inch plywood, or other approved materials.
- Install all plywood wall sheathing to lap joints at Floors. Use 3/4" minimum thickness P.T. plywood nailed with 16d galvanized nails, 4" o.c. along plates, 4" o.c. along all beams top and bottom, and 8" o.c. in the field. At shear walls, use 10d nails @ 4" o.c. along panel edges and 8" o.c. at intermediate supports.
- All framing lumber and plywood shall be pressure treated.
- All pressure treated wood used on residential projects must be free of arsenic and chromium after June 2003. Use ACO or other EPA approved treated lumber on residential projects. On commercial projects, CCI treated lumber is acceptable in concealed spaces.
- ACO arsenic free lumber has been found to corrode standard electroplated galvanized nails and screws. Any metal fasteners (framing or finish) used on ACO pressure treated lumber shall be stainless steel, grade 304 or greater, or hot dip galvanized, conforming to ASTM A-193 / ASTM Standard A463 (Class C-193). Stainless steel and hot dip galvanized metals SHALL NOT come in contact with each other.
- All structural lumber, i.e. joists, girders, beams, rafters, etc., shall be southern yellow pine no. 1 dense, with a minimum Fb of 1800 psi, before pressure treatment. (Pressure treatment reduces fiber stress by 15% to 1100 P.S.I.)

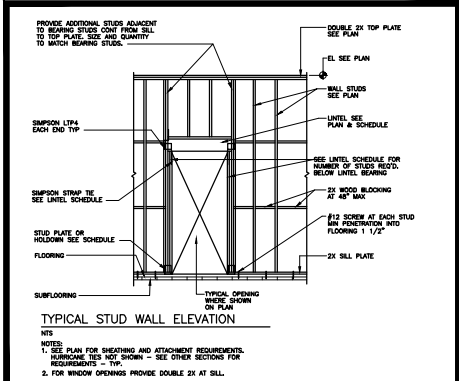

**WOOD LINTEL SCHEDULE (2X4 WALL)**

SPAN	LINTEL	BEARING STUDS	FULL HEIGHT STUDS	STUD PLATE
0'-0" x 6'-0"	2-208	2-204	2-204	L3P4
6'-0" x 6'-0"	2-208	2-204	2-204	L3P4
6'-0" x 6'-0"	2-210	2-204	2-204	L3P4
6'-0" x 6'-0"	2-212	2-204	2-204	L3P4
6'-0" x 10'-0"	2-212	2-204	2-204	MSA

**WOOD LINTEL SCHEDULE (2X6 WALL)**

SPAN	LINTEL	BEARING STUDS	FULL HEIGHT STUDS	STUD PLATE
0'-0" x 6'-0"	2-206	2-208	2-208	L3P4
6'-0" x 6'-0"	2-206	2-208	2-208	L3P4
6'-0" x 6'-0"	2-210	2-208	2-208	L3P4
6'-0" x 6'-0"	2-212	2-208	2-208	L3P4
6'-0" x 10'-0"	2-212	2-208	2-208	MSA

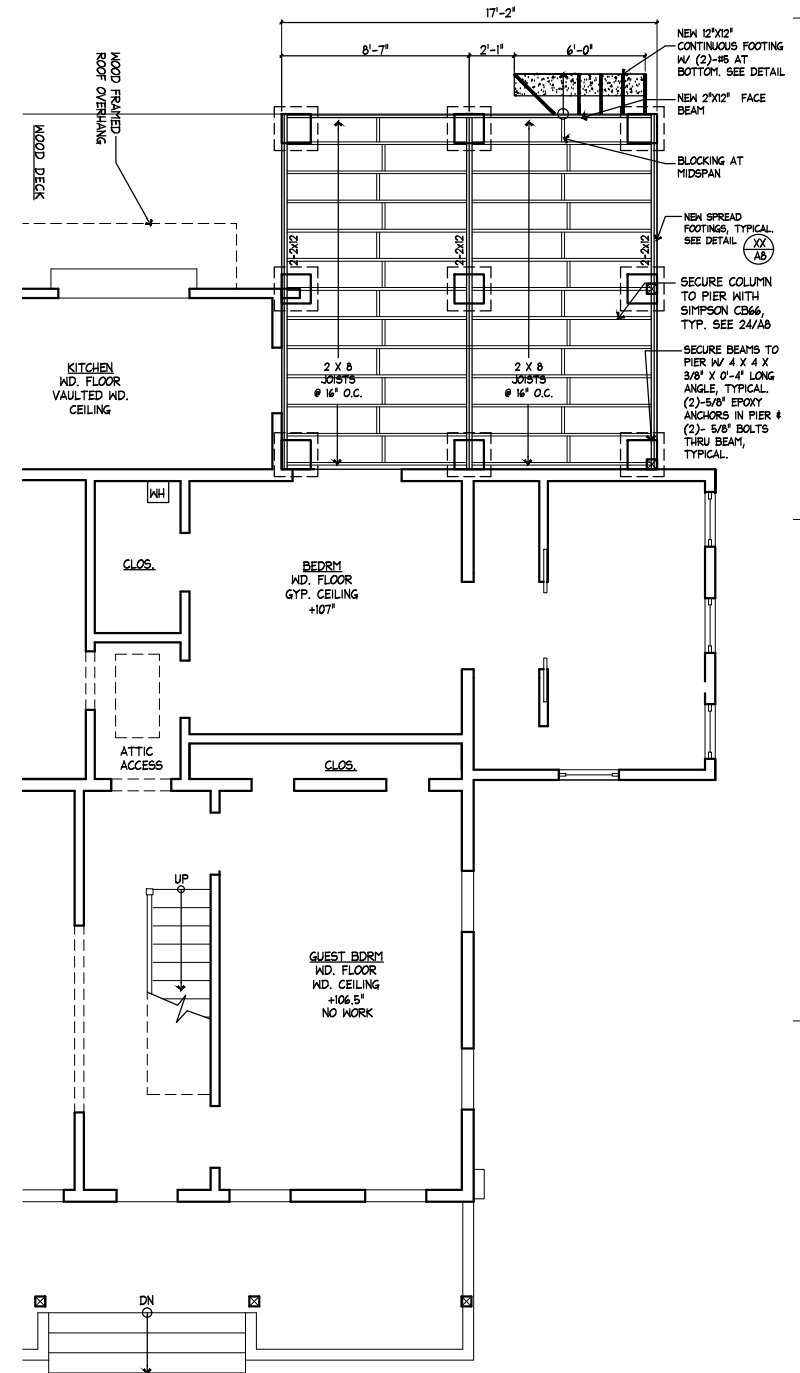
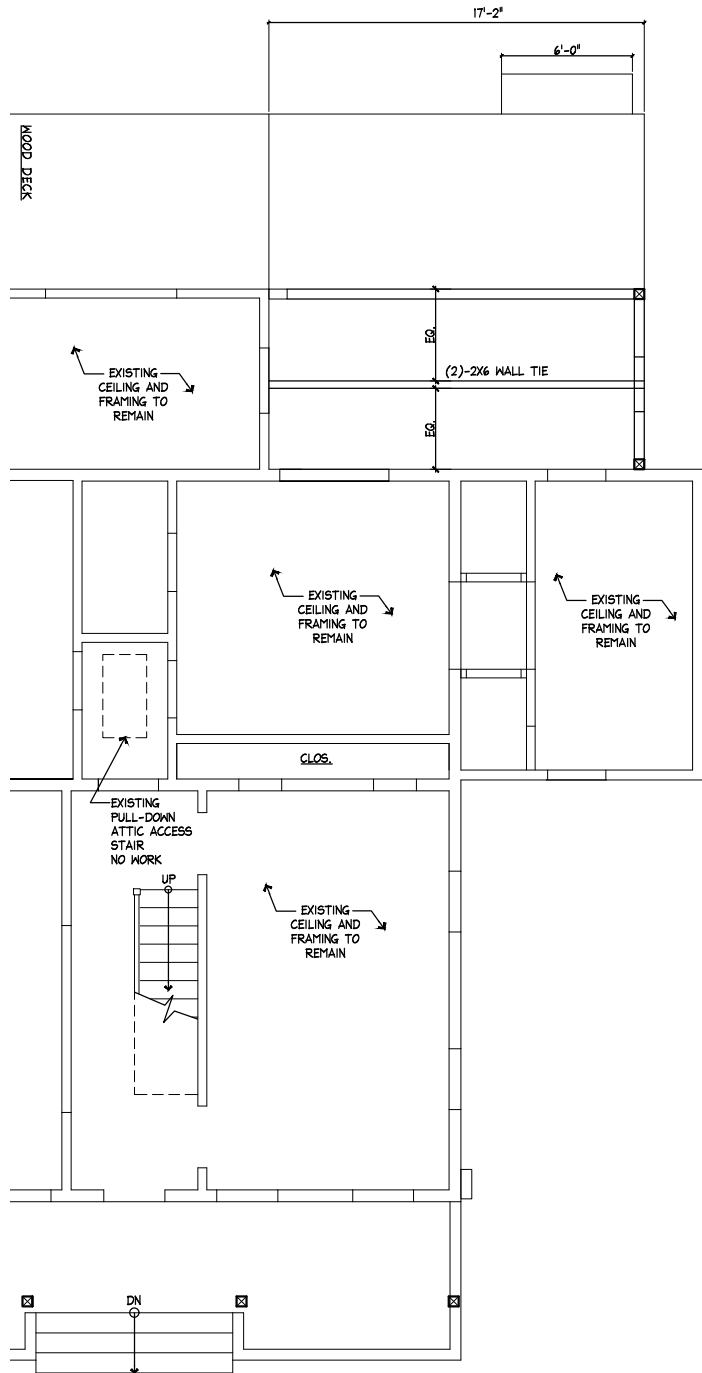
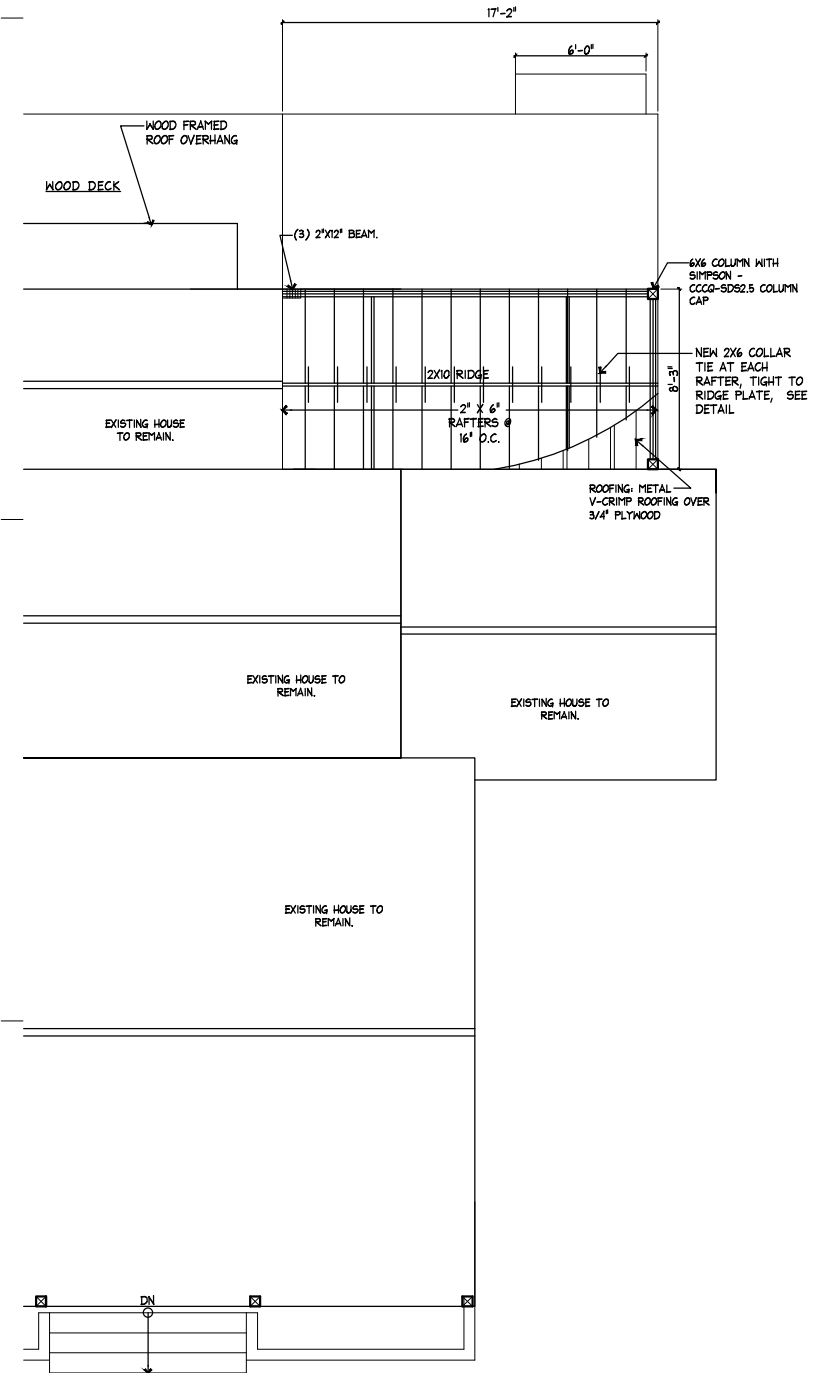

**KRABILL AND JONES RESIDENCE**  
1415 NEWTON STREET  
KEY WEST, FLORIDA, 33040

410 Angela Street  
Key West, Florida 33040  
Telephone (305) 286-1347  
Facsimile (305) 286-2727  
Florida License AAC002022

*Bender & Associates*  
**ARCHITECTS** p.c.

Project No: 1526  
FOUNDATION AND FLOOR FRAMING.  
Date: 10/01/15

**A3.0**  
4 OF 13

## ROOM FINISH SCHEDULE

NO.	ROOM NAME	FLOOR	BASE	WALLS				CEILING	CLG. HT.	REMARKS
				NORTH	EAST	SOUTH	WEST			
101	BATHROOM	CER. TILE	NEW 1X6 WITH TOP CAP	PAINTED M.R. GYP. BD.	PAINTED M.R. GYP. BD.	PAINTED M.R. GYP. BD.	PAINTED M.R. GYP. BD.	PAINTED M.R. GYP. BD.	102'	
102	CLOSET	STAINED 1X4 T&G WOOD	NEW 1X6 WITH TOP CAP	PAINTED GYP. BD.	PAINTED GYP. BD.	PAINTED GYP. BD.	PAINTED GYP. BD.	PAINTED GYP. BD.	102'	
103	CLOSET	STAINED 1X4 T&G WOOD	NEW 1X6 WITH TOP CAP		PAINTED GYP. BD.	PAINTED GYP. BD.	PAINTED GYP. BD.	1/2 V-GROOVE PAINTED WD.	102'	
104	SHOWER	CER. TILE	NEW 1X6 WITH TOP CAP	CER. TILE	CER. TILE	GLASS SHOWER ENCLOSURE	CER. TILE	PAINTED M.R. GYP. BD.	102'	PAINTED CUBAN TILES???

## DOOR HARDWARE

GROUP #1 EXTERIOR DOUBLE DOOR	GROUP #2 INTERIOR SWING CLOSET DOOR	GROUP #3 INTERIOR POCKET DOOR
(1) EXTERIOR LOCKSET (1) DEADBOLT WITH INTERIOR THUMBTURN (1) SET HEAD & FOOT BOLTS WEATHERSTRIPPING & THRESHOLD PER N.O.A.	(1 1/2) PR. BUTTS (1) MAGNETIC BALL CATCH (1) DOORSTOP ON THE HINGE	HEAVY DUTY SLIDING POCKET DOOR HARDWARE. POCKET DOOR PULLS EACH SIDE
EXTERIOR SHUTTERS: RESTORE PAIR OF EXISTING LOUVERED SHUTTERS. RESTORE EXISTING HARDWARE.	TRANSOM DOOR ABOVE: PROVIDE BALL CATCH AND 1 PAIR HINGES.	

DOOR HARDWARE NOTE: OWNER TO SELECT ALL DOOR HARDWARE. CONTRACTOR TO PROVIDE AND INSTALL.  
DOOR HARDWARE ALLOWANCE: \$500 EACH DOOR.

## WINDOW SCHEDULE

MARK	SIZE		MANUFACTURER	DETAILS	MATERIAL	FINISH	REMARKS
	WIDTH	HEIGHT					
A	2'-6"	2'-8"	MARVIN WJAWN 3032	10/A8	WOOD	PAINTED	NEW MARVIN WOOD ANNING WINDOW. NEW PAINTED WOOD BOARD SHUTTER.
B	2'-6"	2'-8"	MARVIN WJAWN 3032	10/A8	WOOD	PAINTED	NEW MARVIN WOOD ANNING WINDOW. NEW PAINTED WOOD BOARD SHUTTER.

## WINDOW TYPES

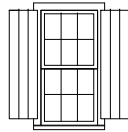

MARK A  
NEW MARVIN PAINTED WD.  
6/6 DOUBLE HUNG WINDOW.  
NEW PAINTED WD. BOARD SHUTTER. SEE  
DTL. X/A8, X/A8.

- WINDOW NOTES:  
1. SHUTTERS WITH OPERABLE LOUVERS NOTED IN WINDOW MARK 'A' SHALL MATCH EXISTING. 1 3/8" THICK SHUTTERS WITH 1-7/8" OPERABLE LOUVERS AND CENTER RAIL. WESTERN RED CEDAR. AVAILABLE FROM LARSON SHUTTER CO., WWW.LARSONSHUTTER.COM, OR ARCHITECT APPROVED ALTERNATE.  
2. QUALIFIED WINDOW RESTORERS FOR WINDOW MARK 'A' INCLUDE JIMMY WRAY (923-4778), HANSEN AND BRINGLE, AND CCS RESTORATION OF SANFORD, FL (407-928-8620). THESE WINDOWS ARE RESTORABLE.

## DOOR SCHEDULE

NO.	TYPE	SIZE			MATERIAL	FINISH	GLAZING	FRAMES		DETAILS	REMARKS	HARDWARE GROUP
		W.	H.	T.				MATERIAL	FINISH			
1	A	48"	80"	1 3/4"	WOOD	PAINTED	IMPACT	WOOD	PAINTED	INSTALL PER MIAMI DADE NOA	NEW FRENCH DOORS, IMPACT GLASS	GROUP 1
2	A	36"	80"	1 3/4"	WOOD	PAINTED	IMPACT	WOOD	PAINTED	INSTALL PER MIAMI DADE NOA	NEW FRENCH DOOR. IMPACT GLASS.	GROUP 1
3	B	30"	80"	1 3/4"	WOOD	PAINTED	NONE.	WOOD	PAINTED	5/A8	NEW SOLID CORE WOOD INTERIOR DOOR	GROUP 2
4	B	30"	80"	1 3/4"	WOOD	PAINTED	NONE.	WOOD	PAINTED	5/A8	NEW SOLID CORE WOOD INTERIOR DOOR	GROUP 2
5	C	24"	80"	1 3/8"	WOOD	PAINTED	NONE.	WOOD		14/A8	NEW 4 PANEL PAINTED WD. POCKET DOORS	GROUP 3
6	C	24"	80"	1 3/8"	WOOD	PAINTED	NONE.	WOOD		14/A8	NEW 4 PANEL PAINTED WD. POCKET DOORS	GROUP 3

## DOOR TYPES

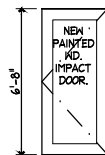

MARK A  
PAINTED WD. IMPACT FRENCH DOOR  
MARVIN SWINGING FRENCH DOOR



MARK B  
NEW SOLID CORE WOOD PAINTED 4 PANEL INTERIOR DOOR

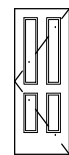

MARK C  
NEW SOLID CORE WOOD PAINTED 4 PANEL INTERIOR POCKET DOOR

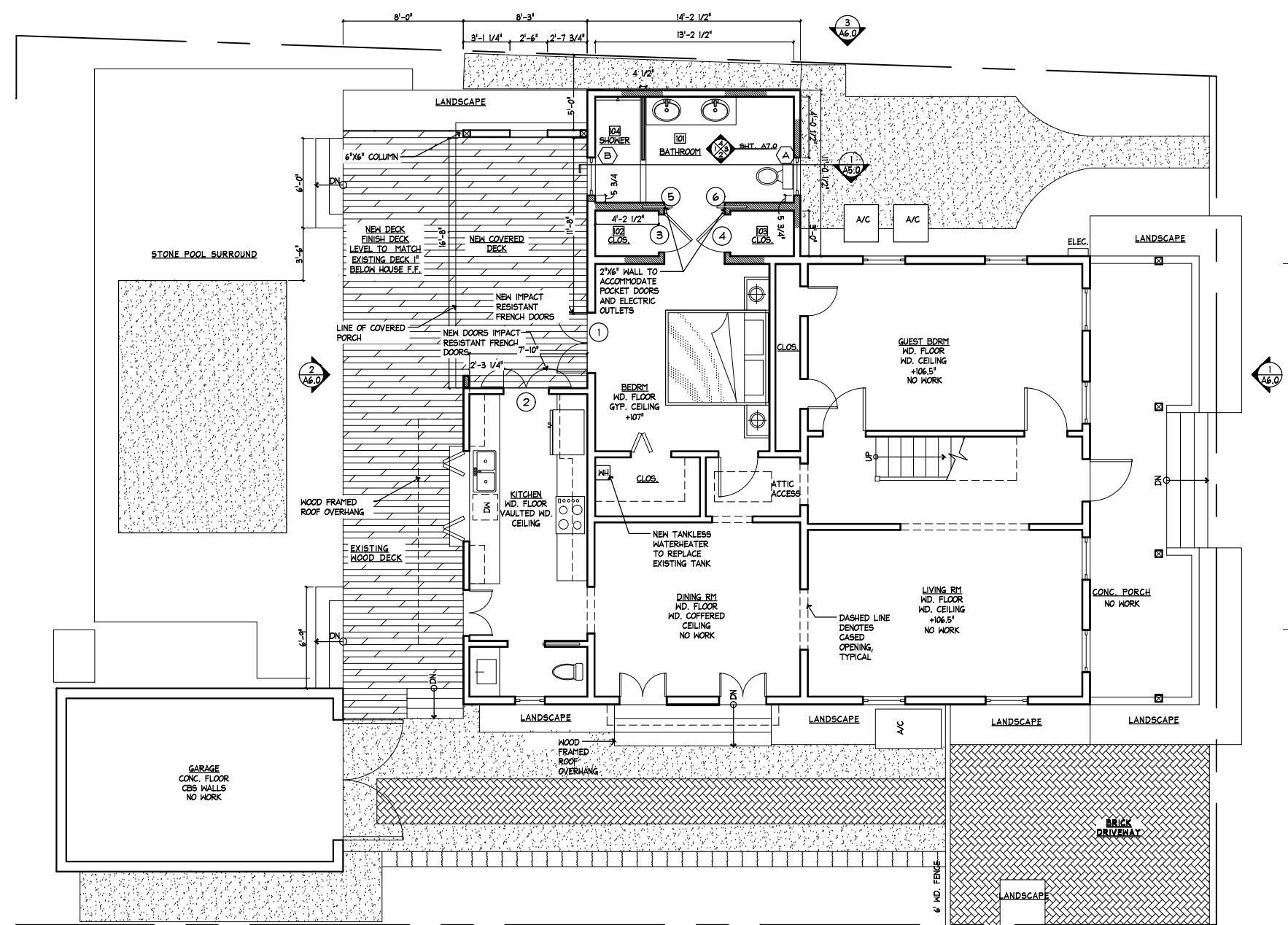

1 PROPOSED FLOOR PLAN - OPTION A  
A4.0 SCALE: 1/4"=1'-0"

KRABILL AND JONES RESIDENCE  
1415 NEWTON STREET  
KEY WEST, FLORIDA, 33040

410 Angela Street  
Key West, Florida 33040  
Telephone (305) 296-1347  
Facsimile (305) 296-2727  
Florida License AAC002022

Bender & Associates  
ARCHITECTS  
p.c.

Project No: 1526

PROPOSED FLOOR PLAN AND SCHEDULES

Date: 10/01/15

A4.0

5 OF 13

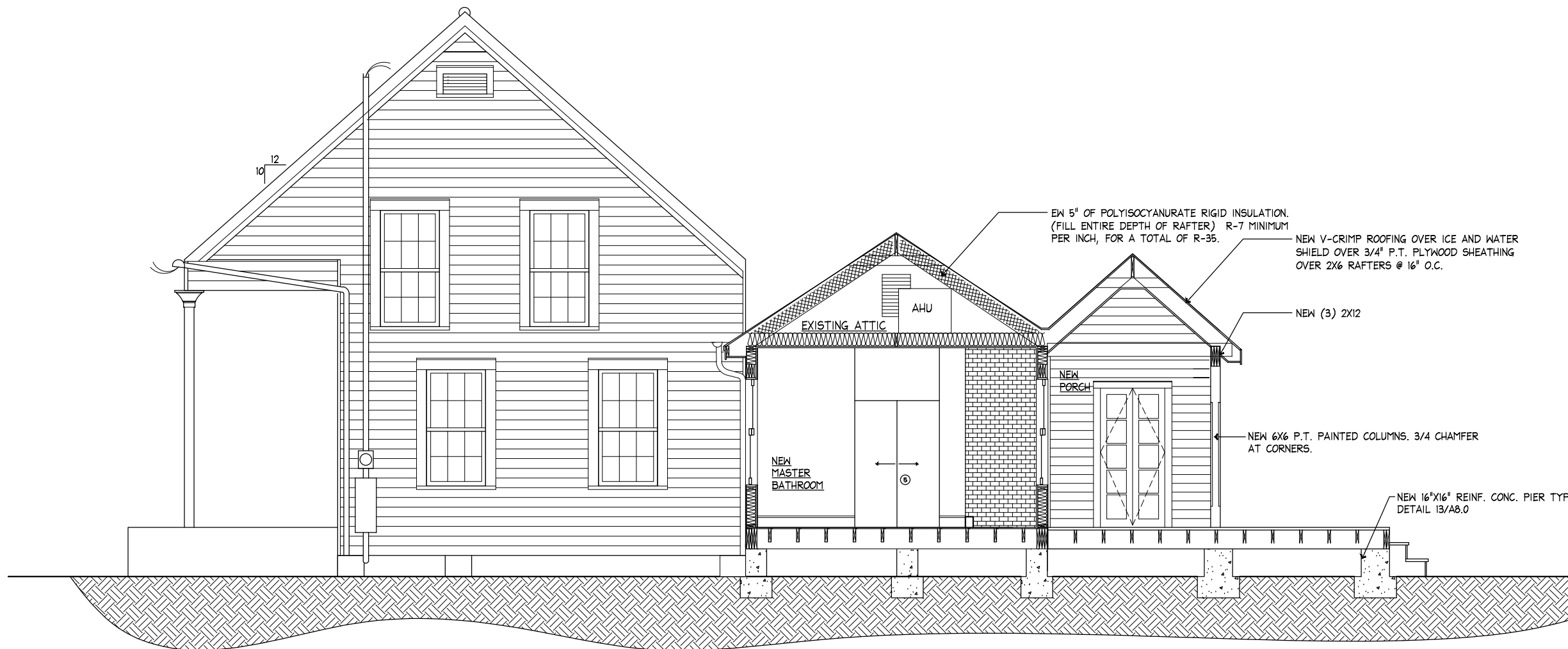

1 SECTION AT BATHROOM LOOKING WEST  
 A5.0 SCALE: 3/8"=1'-0"

KRABILL AND JONES RESIDENCE  
 1415 NEWTON STREET  
 KEY WEST, FLORIDA, 33040

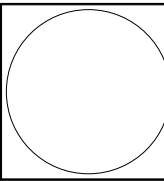

410 Angela Street  
 Key West, Florida 33040  
 Telephone (305) 296-1347  
 Facsimile (305) 296-2727  
 Florida License AAC002022

Bender & Associates  
 ARCHITECTS p.a.

Project No: 1526  
 BUILDING SECTIONS  
 Date: 10/01/15

A5.0  
 6 OF 13

**KRABILL AND JONES RESIDENCE**  
 1415 NEWTON STREET  
 KEY WEST, FLORIDA, 33040

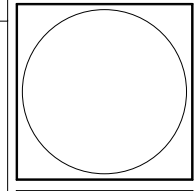

410 Angela Street  
 Key West, Florida 33040  
 Telephone (305) 296-1347  
 Facsimile (305) 296-2727  
 Florida License AAC002022

*Bender & Associates*  
**ARCHITECTS** p.a.

Project No: 1526  
 PROPOSED EXTERIOR ELEVATIONS  
 Date: 10/01/15

**A6.0**  
 7 OF 13



**3 PROPOSED EAST EXTERIOR ELEVATION**  
 A6.0 SCALE: 1/4"=1'-0"

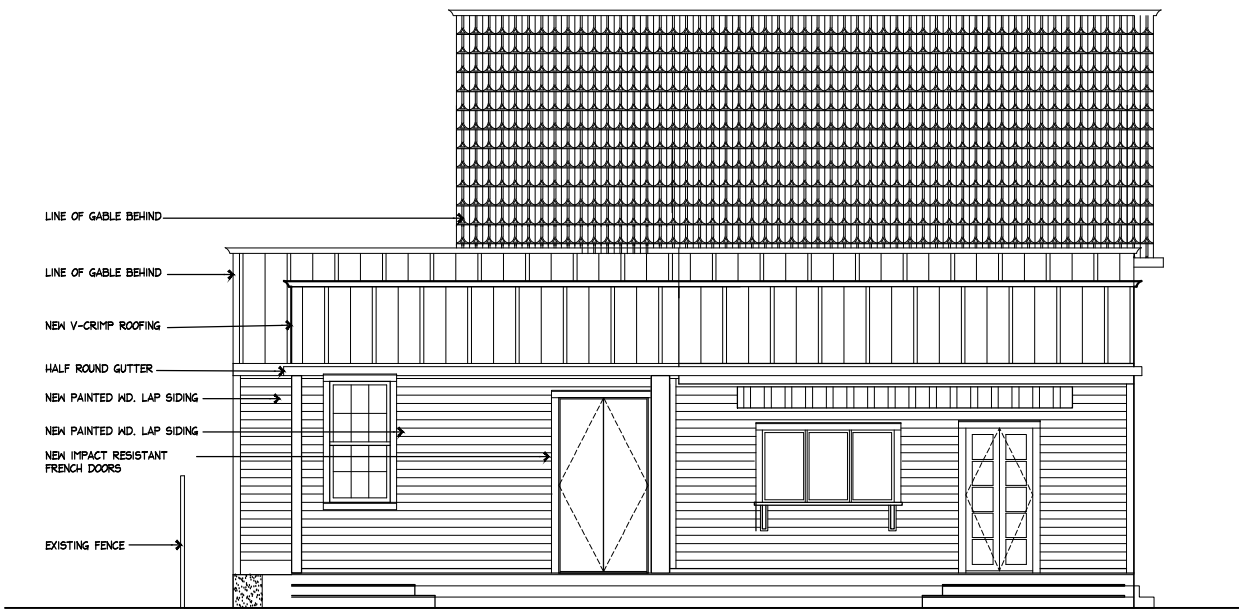

**2 PROPOSED SOUTH EXTERIOR ELEVATION**  
 A6.0 SCALE: 1/4"=1'-0"



**1 PROPOSED NORTH EXTERIOR ELEVATION**  
 A6.0 SCALE: 1/4"=1'-0"

PLUMBING SCHEDULE				
MARK	FIXTURE	MFR./CATALOG NO.	LOCATION	REMARKS
WC-1	TOILET	KOHLER - KATHRYN COMFORT HEIGHTS, COMPACT ELONGATED, 1.28/1.1 GPF FLUSH VALVE - EC (WHITE). PRODUCT # K-3940-0	SEE PLAN	--
LAV-1	WALL MOUNT SINK	KOHLER-SOLD/EXPRESSIONS/ 61" VANITY TOP WITH DOUBLE VERTICYL RECTANGULAR CUTOUT		PROVIDE 3/4" PLYWOOD BACKING AT ALL WALL MOUNT SINKS. CARRIER ARM FOR SUPPORT
F-1	FAUCET	KOHLER ALTEO CENTERSET BATHROOM SINK FAUCET WITH LEVER HANDLES	SEE INTERIOR ELEVATIONS	

NOTES:  
 - PROVIDE PLYWOOD BACKING FOR ALL WALL MOUNTED LAVATORIES, TOILET PARTITIONS AND TOILET ACCESSORIES.  
 - INSTALL LAVATORIES & TOILETS ACCORDING TO MANUFACTURERS SPECIFICATIONS TO MEET ADA REQUIREMENTS.

BATHROOM ACCESSORY SCHEDULE			
MARK	FIXTURE	MFR./CATALOG NO.	REMARKS
M-1	MIRROR	KOHLER - REVIVAL OVAL MIRROR - PRODUCT # K-1616-CP	SEE INTERIOR ELEVATIONS FOR SIZE.
VA-1	VANITY	KOHLER - DAMASK 60" VANITY WITH FURNITURE LEGS PRODUCT # K-99524-1G-1WA	PROVIDE BACKING AS REQUIRED FOR INSTALLATION
TP-1	TP HOLDER	KOHLER - ANTIQUE - POLISHED CHROME- PRODUCT # K-211-CP	PROVIDE BACKING AS REQUIRED FOR INSTALLATION
TB-1	TOWEL BAR	KOHLER - ANTIQUE 24" TOWEL BAR - PRODUCT # K-206-PC	

NOTES:  
 - PROVIDE PLYWOOD BACKING FOR ALL WALL MOUNTED LAVATORIES, TOILET PARTITIONS AND TOILET ACCESSORIES.  
 - INSTALL LAVATORIES & TOILETS ACCORDING TO MANUFACTURERS SPECIFICATIONS TO MEET ADA REQUIREMENTS.

**KRABILL AND JONES RESIDENCE**  
 1415 NEWTON STREET  
 KEY WEST, FLORIDA, 33040

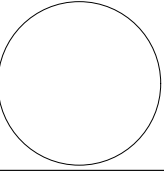

410 Angela Street  
 Key West, Florida 33040  
 Telephone (305) 296-1347  
 Facsimile (305) 296-2727  
 Florida License AAC002022

*Bender & Associates*  
**ARCHITECTS** p.d.

Project No: 1526  
 INTERIOR ELEVATIONS  
 Date: 10/01/15

**A7.0**

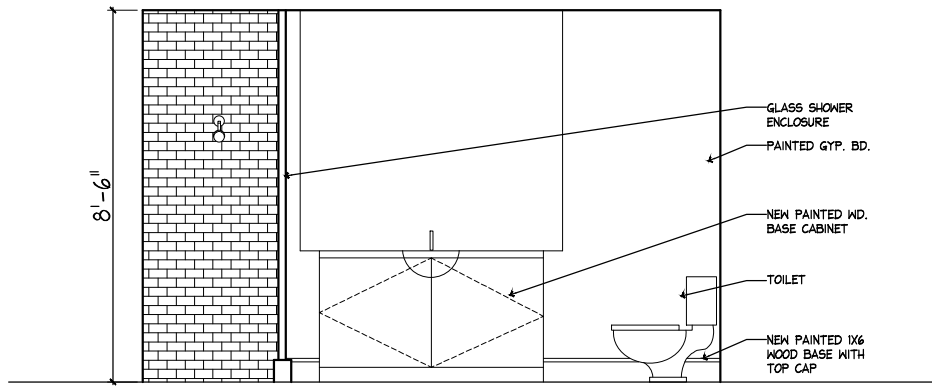

**4 SOUTH INTERIOR ELEVATION**  
 SCALE: 1/2"=1'-0"

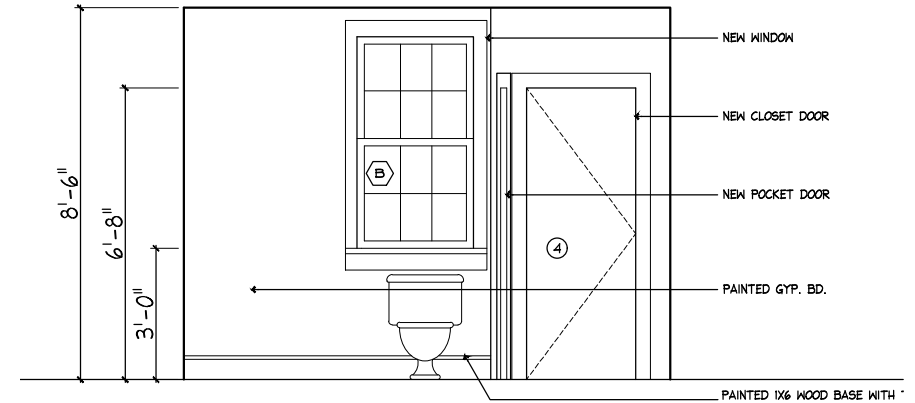

**3 WEST INTERIOR ELEVATION**  
 SCALE: 1/2"=1'-0" SCALE: 1/4"=1'-0"

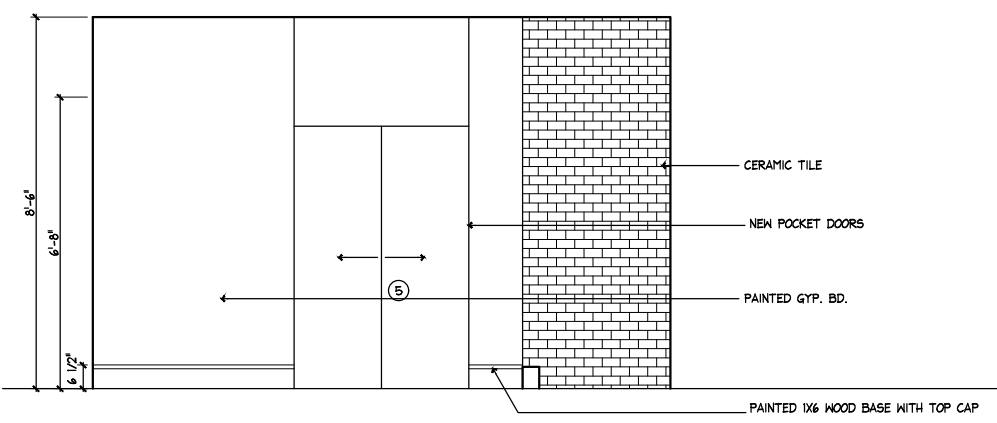

**2 NORTH INTERIOR ELEVATION**  
 SCALE: 1/2"=1'-0"

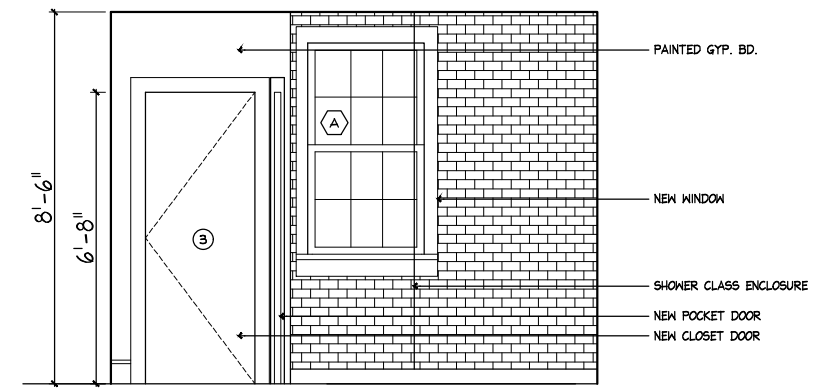

**1 EAST INTERIOR ELEVATION**  
 SCALE: 1/2"=1'-0"

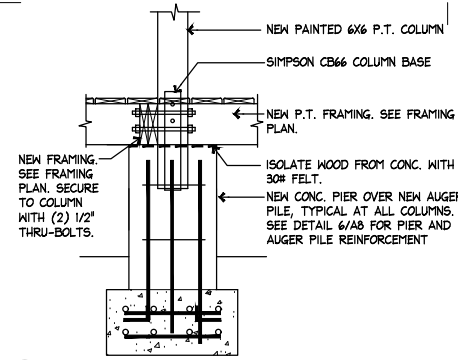

15 COLUMN - FOOTING CONNECTION  
SCALE: 3/4"=1'-0"

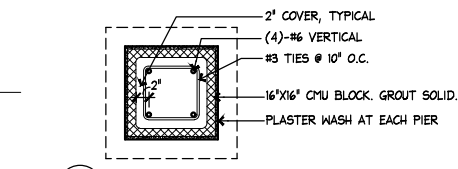

18a PIER REINFORCING

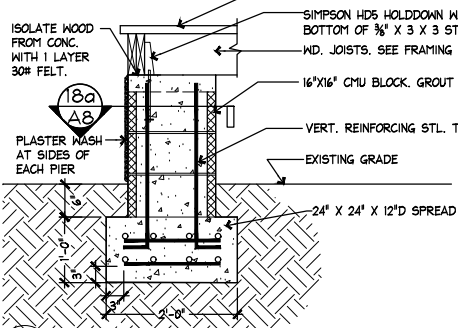

18a FOUNDATION PIER & FOOTING  
SCALE: 3/4"=1'-0"

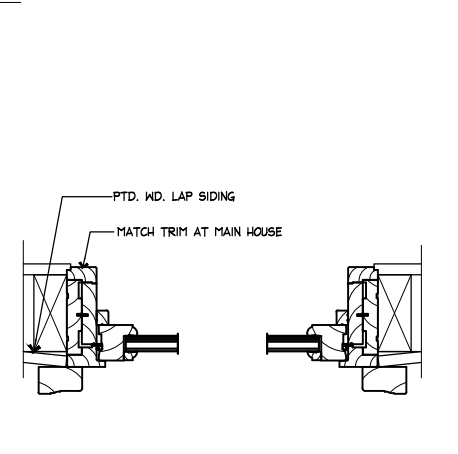

10 DH WINDOW JAMB  
SCALE: 3"=1'-0"

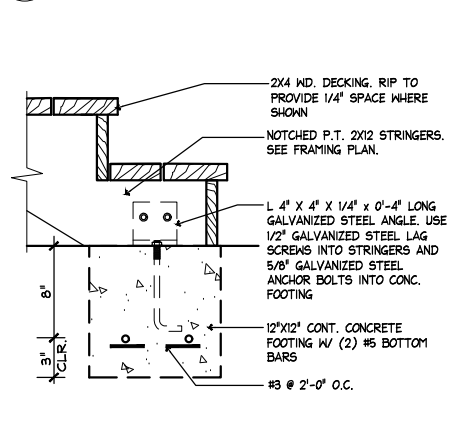

6 DETAIL  
SCALE: 1 1/2"=1'-0"



9 DH WINDOW HEAD, SILL  
SCALE: 3"=1'-0"

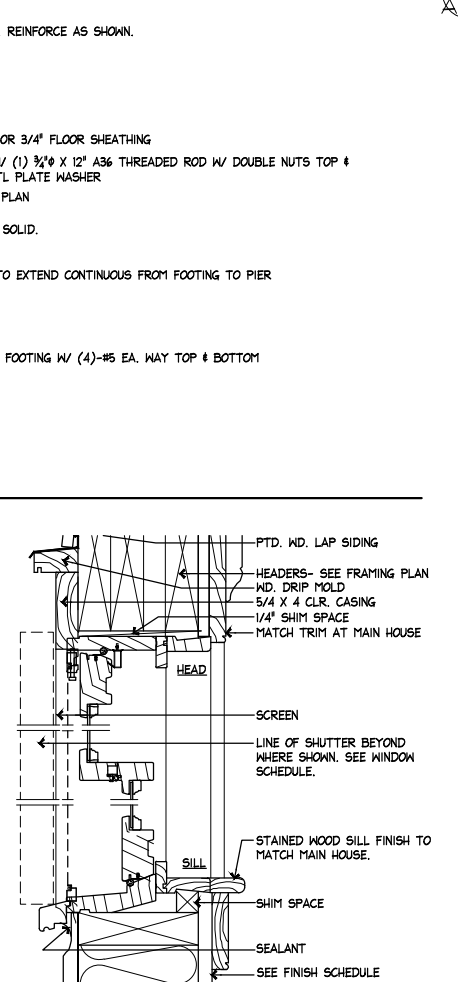

5 INTERIOR DOOR HEAD, JAMB DETAIL  
SCALE: 3"=1'-0"

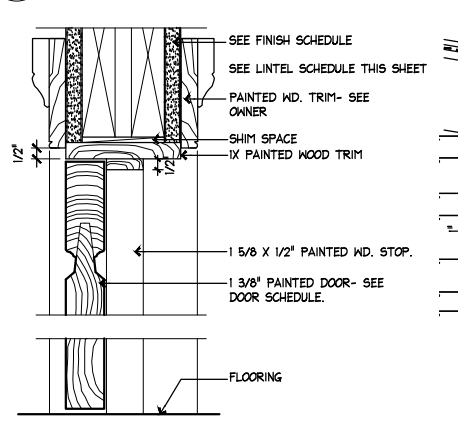

4 REAR PORCH COLUMN-BEAM  
SCALE: 1 1/2"=1'-0"

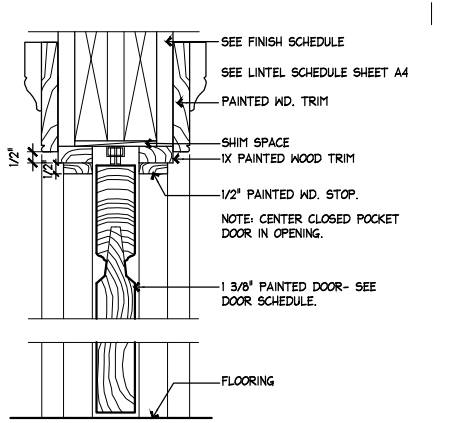

14 POCKET DOOR HEAD, JAMB DETAIL  
SCALE: 3"=1'-0"

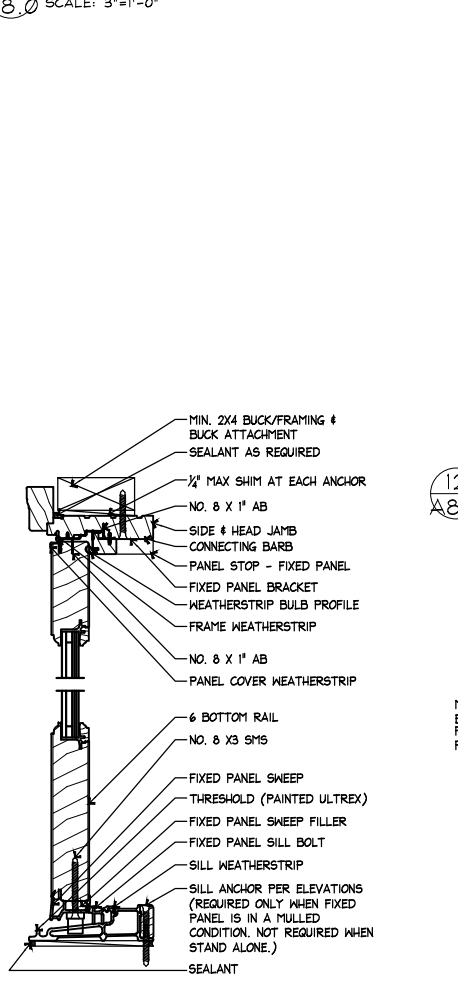

8 EXTERIOR DOOR HEAD, JAMB DETAIL  
SCALE: 3"=1'-0"

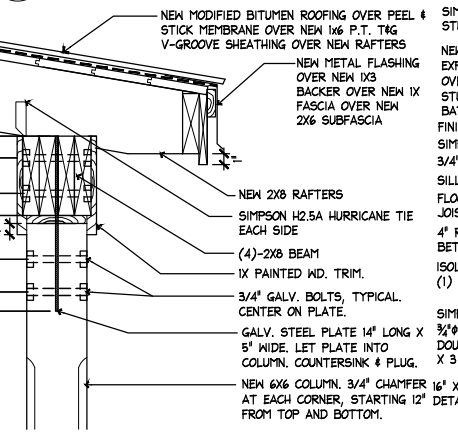

3 FLOOR - WALL DETAIL  
SCALE: 1 1/2"=1'-0"

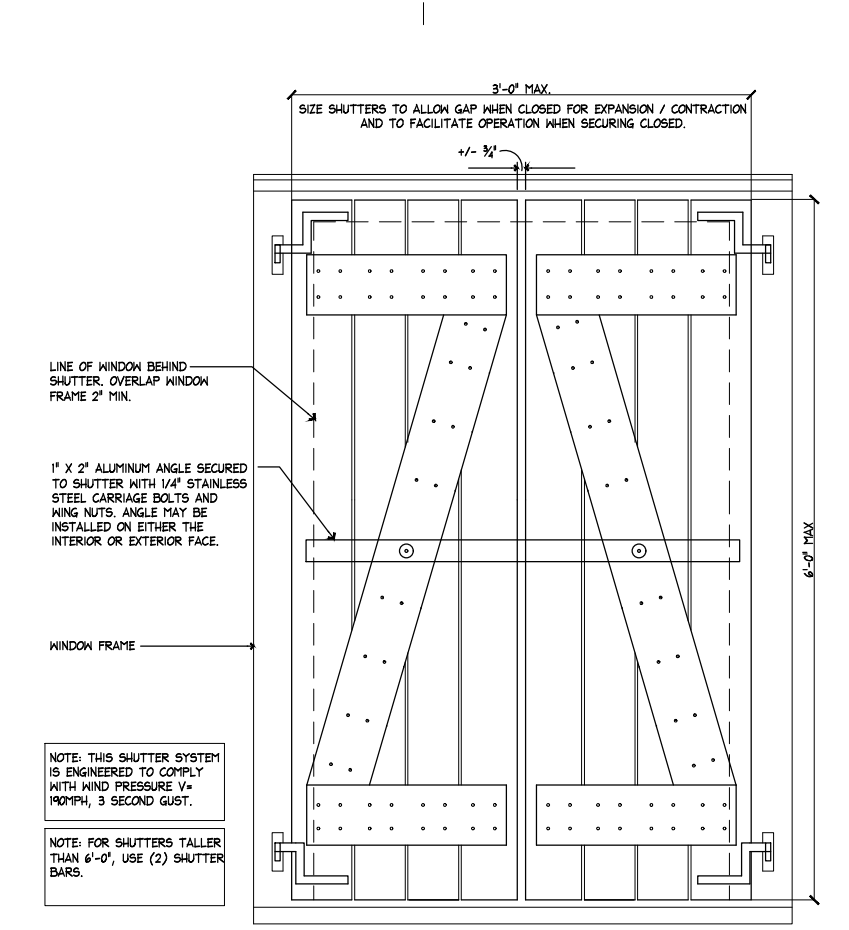

12 SHUTTER DETAIL  
SCALE: 1 1/2"=1'-0"

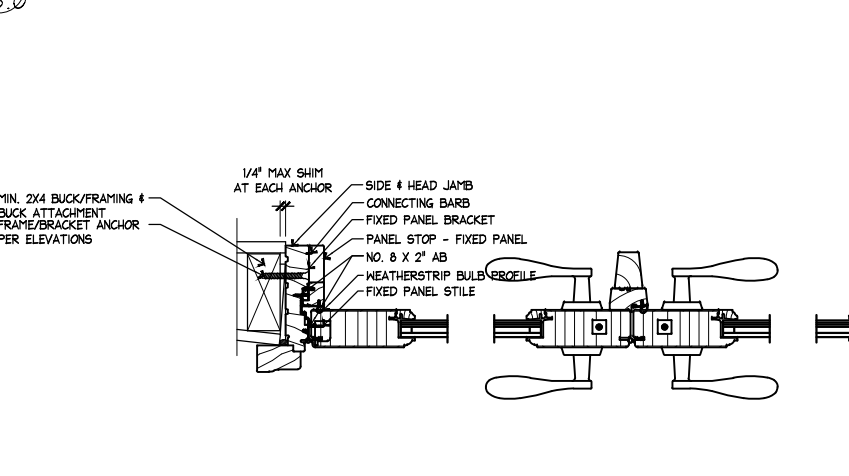

7 EXTERIOR DOOR JAMB  
SCALE: 3"=1'-0"

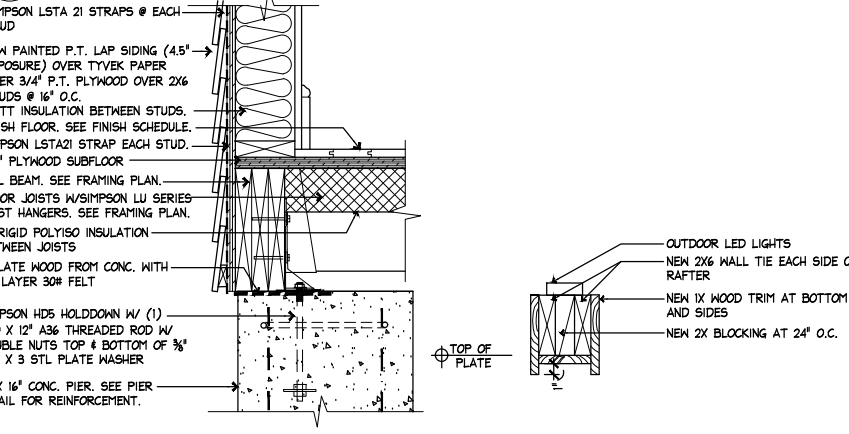

2 WALL TIE DETAIL  
SCALE: 3/4"=1'-0"

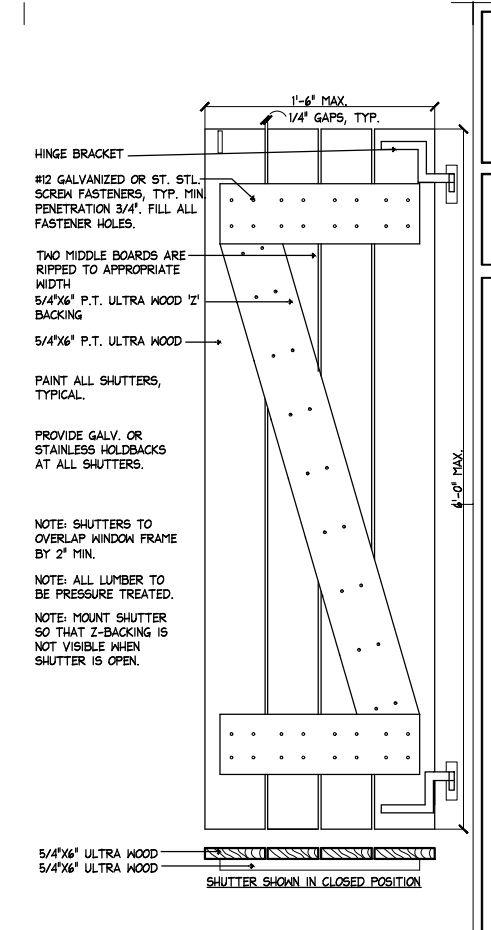

11 SHUTTER DETAIL  
SCALE: 1 1/2"=1'-0"

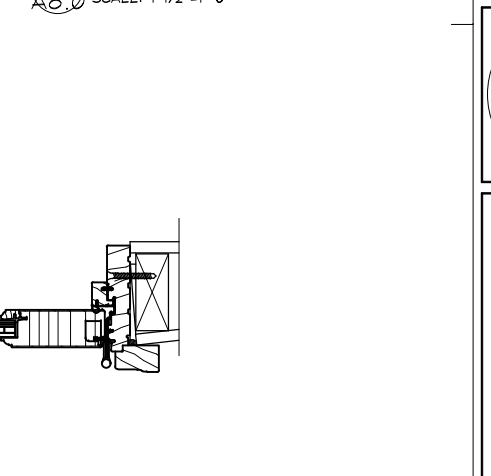

1 ROOF RIDGE DETAIL  
SCALE: 1 1/2"=1'-0"

REVISIONS:

KRABILL AND JONES RESIDENCE  
1415 NEWTON STREET  
KEY WEST, FLORIDA, 33040

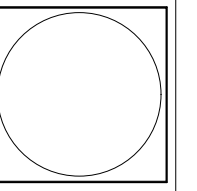

410 Angela Street  
Key West, Florida 33040  
Telephone (305) 296-1347  
Facsimile (305) 296-2727  
Florida License AAC002022

Bender & Associates  
ARCHITECTS  
p.c.

Project No: 1526  
DETAILS  
Date: 10/01/15

A8.0  
9 OF 13

ELECTRICAL SYMBOL LEGEND			
SYMBOL	DESCRIPTION	SYMBOL	DESCRIPTION
	DUPLEX CONVENIENCE RECEPTACLE OUTLET		CEILING MOUNTED INCANDESCENT OR CF FIXTURE
	WEATHERPROOF DUPLEX OUTLET		RECESSED INCANDESCENT OR CF LIGHT FIXTURE
	GROUND FAULT INTERRUPTED DUPLEX OUTLET		WALL MOUNT INCANDESCENT OR CF LIGHT FIXT.
	QUADRUPLEX RECEPTACLE OUTLET		RECESSED CEILING MOUNTED EXHAUST FAN
	SPECIAL PURPOSE OUTLET - 120V		RECESSED CEILING MOUNTED EXHAUST FAN / LIGHT COMBINATION
	SPECIAL PURPOSE OUTLET - 240V		RECESSED CEILING MOUNTED EXHAUST FAN / LIGHT / HEATER COMBINATION
	SPLIT WIRED DUPLEX RECEPTACLE OUTLET W/ TOP RECEPTACLE SWITCHED		SINGLE HEAD SWIVEL FIXTURE (EXTERIOR) W/ MOTION SENSOR DEVICE
	FLUSH FLOOR DUPLEX OUTLET W/ COVER		TWO HEAD SWIVEL FIXTURE (EXTERIOR)
	SPECIAL PURPOSE HARD WIRED CONNECTION		UNDER CABINET LIGHTS
	240V CONNECTION W/ DISCONNECT		FLUORESCENT CEILING FIXTURE
			WALL MTD. INCANDESCENT OR CF STRIP FIXTURE
			CEILING FAN AS SELECTED BY OWNER
	SINGLE POLE SWITCH		CEILING FAN W/ LIGHT KIT AS SELECTED BY OWNER
	3 WAY SWITCH (SWITCHED IN TWO LOCATIONS)		
	4 WAY SWITCH (SWITCHED IN THREE LOCATIONS)		MODULAR TELEPHONE JACK
	DIMMING DEVICE		INTERCOM STATION
	3 WAY DIMMING DEVICE		CABLE TELEVISION OUTLET
	3 SPEED FAN SWITCH		THERMOSTAT
	SPEAKER		LOW VOLTAGE PUSH BUTTON SWITCH (DOORBELL)
			SMOKE DETECTOR

ELECTRICAL FIXTURE SCHEDULE					
MARK	MANUFACTURER / CATALOG NO.	DESCRIPTION	MOUNTING	LAMPS	REMARKS
A	OWNER TO SPECIFY, CONT. TO PROVIDE & INSTALL	BATHROOM LIGHT OVER MIRROR	WALL MOUNT	--	UL DAMP LIST
B	OWNER TO SPECIFY, CONT. TO PROVIDE & INSTALL	RECESSED SHOWER LIGHT	RECESSED	--	WET LIST
C	OWNER TO SPECIFY, CONT. TO PROVIDE & INSTALL	BATHROOM FAN	CEILING	--	WET DAMP LIST
D	OWNER TO SPECIFY, CONT. TO PROVIDE & INSTALL	EXTERIOR 52" CEILING FAN WITH LIGHT	CEILING MOUNT	--	UL WET LIST
E	OWNER TO SPECIFY, CONT. TO PROVIDE & INSTALL	LED STRING LIGHTS	MOUNT ON THE WALL TIE	--	WET LIST
F	OWNER TO SPECIFY, CONT. TO PROVIDE & INSTALL	LED STRING LIGHTS	MOUNT ON THE WALL TIE	--	WET LIST
G	OWNER TO SPECIFY, CONT. TO PROVIDE & INSTALL	RECESSED CLOSET LIGHT	RECESSED	--	
H	OWNER TO SPECIFY, CONT. TO PROVIDE & INSTALL	RECESSED CLOSET LIGHT	RECESSED	--	

- ELECTRICAL NOTES**
- ALL ELECTRICAL WORK SHALL BE PERFORMED IN ACCORDANCE WITH THE NATIONAL ELECTRICAL CODE, FLORIDA BUILDING CODE AND/OR ANY LOCAL CODES AND ORDINANCES.
  - THE ELECTRICAL CONTRACTOR SHALL REFER TO THE ARCHITECTURAL PLANS FOR EXACT LOCATION OF ALL EQUIPMENT. CONTRACTOR SHALL NOT SCALE PLANS.
  - IT IS NOT THE INTENT OF THESE PLANS TO SHOW EVERY AND ALL DETAILS OF CONSTRUCTION. THE ELECTRICAL CONTRACTOR SHALL FURNISH AND INSTALL ALL ITEMS AS TO PROVIDE A COMPLETE ELECTRICAL INSTALLATION WITH ALL EQUIPMENT IN PROPER WORKING ORDER.
  - THE ELECTRICAL CONTRACTOR SHALL BE RESPONSIBLE FOR THE FULL COORDINATION OF HIS WORK WITH THAT OF THE GENERAL CONTRACTOR.
  - IT SHALL BE UNDERSTOOD THAT ALL WORK PERFORMED SHALL BE DONE SO BY A LICENSED ELECTRICAL CONTRACTOR AND IN A FIRST CLASS WORKMANLIKE MANNER.
  - ALL ELECTRICAL WORK AND MATERIAL SHALL BE GUARANTEED FOR A PERIOD OF ONE YEAR OF DATE OF ISSUE OF CERTIFICATE OF OCCUPANCY.
  - ALL POWER AND CONTROL WIRING SHALL BE DONE BY THE ELECTRICAL CONTRACTOR.
  - ALL PANELS SHALL HAVE TYPED DIRECTORIES INDICATING ALL CIRCUITS.
  - LIGHTING FIXTURES INCLUDING LAMPS SHALL BE PROVIDED AND INSTALLED BY THE ELECTRICAL CONTRACTOR.
  - ALL WIRES AND CABLES SHALL BE COPPER EXCEPT AS INDICATED. WIRES SHALL BE #12 MINIMUM SIZE (CONTROL WIRING SHALL BE #14AWG). WIRE SIZES #10 AND SMALLER SHALL BE TW SOLID. WIRE SIZES #8 AND LARGER SHALL BE THW STRANDED.
  - CONTRACTOR SHALL PROVIDE TEMPORARY POWER FOR ALL TRADES.
  - CONTRACTOR SHALL INSTALL LIGHTING FIXTURES PROVIDED BY OTHERS.
  - ALL COPPER WATER PIPE SHALL BE ELECTRICAL BONDED AND GROUNDED.
  - BALANCE LOADS IN ACCORDANCE WITH GOOD CONSTRUCTION PRACTICES.
  - THE ELECTRICAL CONTRACTOR SHALL BE RESPONSIBLE FOR VERIFYING ADEQUATE CIRCUITRY AND BREAKER SIZES WHICH ARE REQUIRED BY THIS CONTRACT.
  - THE CONTRACTOR SHALL FURNISH AND INSTALL APPROVED HARD-WIRED SMOKE DETECTORS IN ACCORDANCE WITH THE REQUIREMENTS OF THE BUILDING DEPARTMENT HAVING JURISDICTION OVER THIS PROJECT.

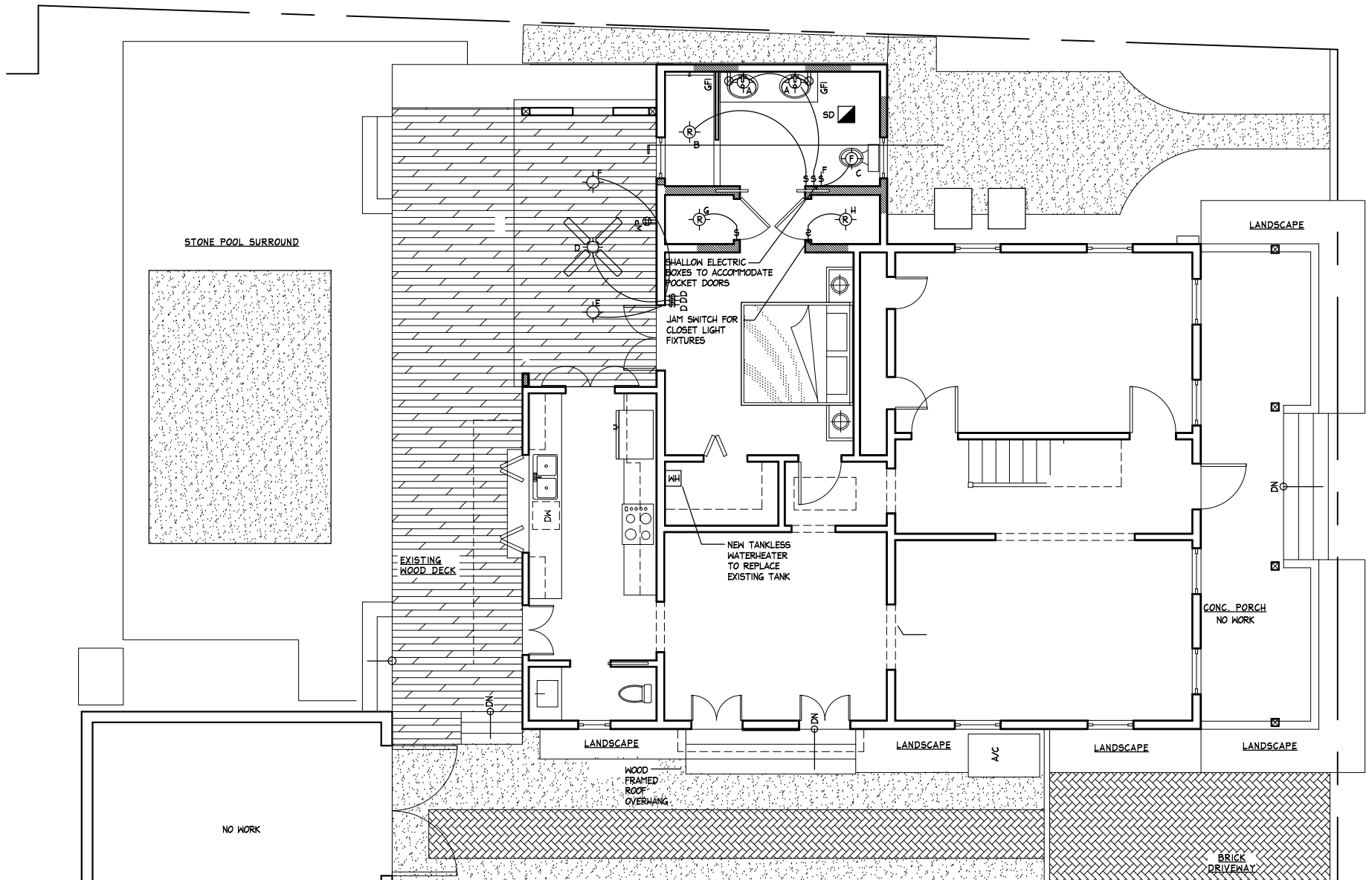
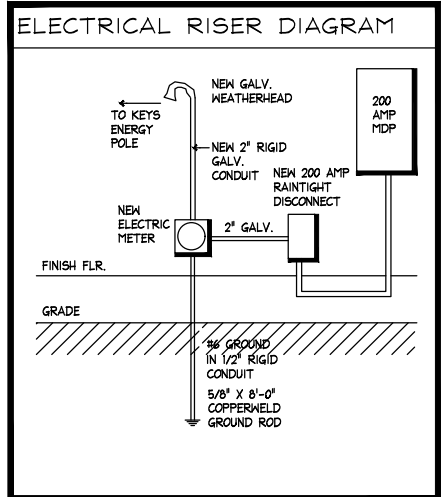

**ELECTRICAL / REFLECTED CEILING PLAN**  
 SCALE: 1/4"=1'-0"

**KRABILL AND JONES RESIDENCE**  
 1415 NEWTON STREET  
 KEY WEST, FLORIDA, 33040

410 Angela Street  
 Key West, Florida 33040  
 Telephone (305) 296-1347  
 Facsimile (305) 296-2727  
 Florida License AAC002022

*Bender & Associates*  
**ARCHITECTS**  
 p.c.

Project No: 1526  
**ELECTRICAL PLANS**  
 SCHEDULES  
 NOTES  
 Date: 10/01/15

**A9.0**  
 10 OF 13



**MECHANICAL GENERAL NOTES:**

- EXISTING CONDITIONS INDICATED ARE TAKEN FROM EXISTING CONSTRUCTION DOCUMENTS, VARIOUS SURVEYS, AND FIELD INVESTIGATIONS. UNFORESEEN CONDITIONS PROBABLY EXIST AND WORK, NEW OR EXISTING, MAY NOT BE LOCATED EXACTLY AS SHOWN ON THE DRAWINGS. COORDINATE WITH FIELD CONDITIONS TO VERIFY EXACT LOCATIONS OF PIPING, DUCTS AND EQUIPMENT. COORDINATE THE WORK OF OTHER TRADES SO THAT INTERFERENCE BETWEEN PIPING, EQUIPMENT, STRUCTURAL, AND ELECTRICAL WORK WILL BE AVOIDED. FAILURE TO COORDINATE THE WORK WILL NOT BE CONSIDERED FOR EXTRAS.
- CONTRACTOR SHALL VISIT AND CAREFULLY EXAMINE THOSE PORTIONS OF THE BUILDING AFFECTED BY THIS WORK BEFORE SUBMITTING PROPOSALS SO AS TO BECOME FAMILIAR WITH EXISTING CONDITIONS AND DIFFICULTIES THAT WILL AFFECT EXECUTION OF WORK. SUBMISSION OF A PROPOSAL WILL BE CONSTRUED AS EVIDENCE THAT SUCH EXAMINATION HAS BEEN MADE AND LATER CLAIMS FOR LABOR, EQUIPMENT OR MATERIALS REQUIRED BECAUSE OF DIFFICULTIES ENCOUNTERED WILL NOT BE RECOGNIZED.
- PROVIDE LABOR, MATERIALS, TOOLS, EQUIPMENT AND DEVICES NECESSARY TO PROVIDE A COMPLETE AND OPERATIONAL SYSTEM IN ACCORDANCE WITH THE INTENT OF THE CONTRACT DRAWINGS AND SPECIFICATION. FULLY TEST, BALANCE, CLEAN AND LEAVE SYSTEMS IN A COMPLETE AND OPERATIONAL STATUS.
- THESE DRAWINGS ARE DIAGRAMMATIC ONLY AND DO NOT SHOW ALL OFFSETS, BENDS, ELBOWS, OR OTHER SPECIFIC ELEMENTS THAT MAY BE REQUIRED FOR PROPER INSTALLATION OF THE WORK. SUCH WORK SHALL BE FIELD VERIFIED AND CAREFULLY COORDINATED WITH ALL BUILDING TRADES AT THE SITE BY THE CONTRACTOR.
- PROTECT SURROUNDING UTILITIES, WALLS, FLOORS AND CEILINGS FROM DAMAGE DURING CONSTRUCTION. THE CONTRACTOR SHALL BEAR ALL EXPENSE FOR REPAIR OR REPLACEMENT OF UTILITIES OR OTHER PROPERTY DAMAGED DURING CONSTRUCTION.
- PROVIDE WOOD, GYP. BD. AND OTHER MATERIALS FOR WALL AND CEILING REPAIR AND OTHER GENERAL WORK AS REQUIRED FOR PROPER INSTALLATION OF MECHANICAL SYSTEMS. ALL REPAIRS SHALL MATCH EXISTING.
- ALL MATERIALS AND EQUIPMENT SHALL BE NEW AND SHALL BE U.L. LISTED WHERE APPLICABLE. INSTALL IN ACCORDANCE WITH MANUFACTURER'S PRINTED INSTALLATION INSTRUCTIONS WITH ADEQUATE ACCESS FOR MAINTENANCE. INSTALLATION OF NEW EQUIPMENT SHALL NOT INTERFERE WITH REQUIRED WORKING CLEARANCES FOR EXISTING EQUIPMENT.
- PROVIDE WORK IN ACCORDANCE WITH 2007 FLORIDA BUILDING CODE - MECHANICAL, AND OTHER LOCAL CODES AND STANDARDS AS ENFORCED. COORDINATE WITH LOCAL CODE AUTHORITIES TO DETERMINE EXACT REQUIREMENTS.
- PROVIDE ALL SUPPLEMENTARY STEEL STRAPS AND FOUNDATIONS FOR SUPPORTS AND BRACING OF ALL HVAC DUCT AND PIPING. EXTERIOR STEEL SHALL BE HOT DIPPED GALVANIZED.
- THIS CONTRACTOR SHALL ARRANGE FOR AND PAY FOR NECESSARY PERMITS, INSPECTIONS, ETC. AS RELATED TO THE WORK SHOWN ON THESE DRAWINGS.
- TEST AND BALANCE SYSTEMS PER NEBB OR AABC. SUBMIT TEST AND BALANCE REPORT IN ACCORDANCE WITH NEBB OR AABC TO THE OWNER'S REPRESENTATIVE. ALL WORK SHALL COMPLY WITH ALL APPLICABLE LAWS, CODES OR INANCES OF THE CITY, COUNTY AND STATE.
- THE MECHANICAL CONTRACTOR SHALL BE RESPONSIBLE FOR VERIFYING THE ADEQUACY OF MECHANICAL SYSTEMS, EQUIPMENT. CALCULATIONS AND SIZING SHALL BE DONE IN ACCORDANCE WITH THE LATEST PUBLISHED LITERATURE OF: THE AMERICAN SOCIETY OF HEATING, VENTILATING AND AIR CONDITIONING ENGINEERS (ASHRAE) AND THE AMERICAN SOCIETY OF MECHANICAL ENGINEERS (ASME).
- WHENEVER NECESSARY FOR THE PROPER FUNCTIONING OF MECHANICAL SYSTEMS, COORDINATE UNDERCUTTING OF DOORS FOR RETURN OF AIR WITH THE GENERAL CONTRACTOR.
- COORDINATE INSTALLATION OF EQUIPMENT WITH ALL OTHER TRADES (i.e. PLUMBING AND ELECTRICAL) TO AVOID INTERFERENCE WITH OTHER EQUIPMENT AND SYSTEMS.
- 

**PLUMBING FIXTURE SCHEDULE**

MARK	FIXTURE	MANUFACTURER / CATALOG NO.	FITTINGS: MANUFACTURER / CATALOG NO.	REMARKS
L-1	BATHROOM LAV	OWNER TO SELECT, CONTRACTOR TO PROVIDE & INSTALL	OWNER TO SELECT, CONTRACTOR TO PROVIDE & INSTALL	
L-2	BATHROOM LAV	OWNER TO SELECT, CONTRACTOR TO PROVIDE & INSTALL	OWNER TO SELECT, CONTRACTOR TO PROVIDE & INSTALL	
WC-1	TOILET	OWNER TO SELECT, CONTRACTOR TO PROVIDE & INSTALL	OWNER TO SELECT, CONTRACTOR TO PROVIDE & INSTALL	
SH-1	BATHROOM SHOWER	OWNER TO SELECT, CONTRACTOR TO PROVIDE & INSTALL	OWNER TO SELECT, CONTRACTOR TO PROVIDE & INSTALL	
WH-1	ON DEMAND WATER HTR	TAKAGI OR EQUAL		

**PLUMBING GENERAL NOTES:**

- UTILITIES AND SERVICES INDICATED ARE TAKEN FROM VARIOUS OLD AND NEW SURVEYS, AS-BUILT RECORDS AND FIELD INVESTIGATIONS. UNFORESEEN CONDITIONS PROBABLY EXIST AND NEW WORK MAY NOT BE FIELD LOCATED EXACTLY AS SHOWN ON DRAWINGS. COOPERATION WITH OTHER TRADES IN ROUTING, AS DETERMINED DURING CONSTRUCTION WILL BE NECESSARY.
- FIELD VERIFY EXISTING INSTALLATIONS. MODIFY EXISTING PLUMBING SYSTEMS, WHICH ARE TO REMAIN ACTIVE, TO FACILITATE RECONNECTION AND EXTENSION OF THE NEW WORK.
- PLANS ARE NOT COMPLETELY TO SCALE. PIPE ROUTING SHOWN IS SCHEMATIC AND IS NOT INTENDED TO INDICATE EXACT ROUTING AND ANY ADDITIONAL OFFSETS AND FITTINGS REQUIRED FOR PROPER INSTALLATION AND TO MAINTAIN CLEARANCES. VERIFY STRUCTURAL, MECHANICAL AND ELECTRICAL INSTALLATION AND OTHER POTENTIAL OBSTRUCTIONS AND ROUTE PIPING TO AVOID INTERFERENCES.
- CONCEAL PIPING ABOVE CEILINGS, WITHIN WALLS OR CHASES EXCEPT AS SPECIFICALLY NOTED.
- SLEEVE AND FIRE STOP PENETRATIONS OF RATED WALLS, FLOORS, CEILING AND ROOFS.
- PROVIDE ACCESS PANELS TO ALL VALVES AND WATER HAMMER ARRESTERS LOCATED WITHIN CHASES OR NON-ACCESSIBLE CEILINGS. REFER TO ARCHITECTURAL DRAWINGS FOR CEILING TYPES.
- ALL WATER PIPING SHALL BE TYPE "L" COPPER PIPE WITH SOLDERED (95/5) JOINTS.
- SCHEDULE 40 PVC PIPE & FITTINGS: ASTM D2466-86. JOINTS: ASTM D2855-83, SOLVENT WELD.
- ESCUTCHEONS SHALL BE PROVIDED FOR ALL PIPING THRU WALLS, FLOORS AND CEILINGS WHERE PIPE IS EXPOSED TO VIEW.
- SEE ARCHITECTURAL DRAWINGS FOR FIXTURE LOCATIONS AND MOUNTING HEIGHTS.
- PROVIDE AUTOMATIC TRAP PRIMERS FOR FLOOR DRAIN TRAP SEALS.
- PROVIDE, WHEN REQUIRED BY CODE, AN AIR GAP SERVING INDIVIDUAL FIXTURES, DEVICES, APPLIANCES AND APPARATUS.
- SIZE AND LOCATION OF ANY REQUIRED CLEANOUTS SHALL BE IN ACCORDANCE WITH THE FLORIDA BUILDING CODE - PLUMBING, LATEST EDITION, AND ALL JURISDICTION REGULATIONS.
- ALL WALL MOUNTED LAVATORIES AND HAND WASHING FACILITIES SHALL BE ATTACHED TO A FLOOR MOUNTED CARRIER DESIGNED TO WITHSTAND A VERTICAL LOAD OF 250 POUNDS ON THE FRONT OF THE FIXTURE.
- PLUMBING CONTRACTOR SHALL PROVIDE SANITARY WASTE, VENT, DOMESTIC WATER, ETC., ROUGH-IN AND MAKE FINAL CONNECTIONS (INCLUDING SUPPLYING AND/OR INSTALLING ALL NECESSARY RELATED STOPS, VALVES, TRAPS, ETC. AND MAKE READY FOR USE) TO ALL EQUIPMENT WHETHER FURNISHED BY THIS CONTRACTOR OR FURNISHED BY OTHERS.
- INSULATE HOT AND COLD WATER PIPING WITH FACTORY FORMED, FIBERGLASS PIPE INSULATION FACTORY JACKETED SYSTEM 1" THICK EQUAL TO OWENS-CORNING FIBERGLASS 25/ASJ/95L.
- 

**AIR CONDITIONING SYSTEM NOTE:**

VERIFY ELECTRICAL REQUIREMENTS OF AIR CONDITIONING SYSTEM AHU'S AND CONDENSORS AND PROVIDE ACCORDINGLY. PROVIDE DEDICATED CIRCUITS FOR EACH UNIT, AND CUTOFF SWITCHES AND CONVENIENCE OUTLETS PER CODE REQUIREMENTS.

**APPLIANCE NOTE:**

VERIFY ELECTRICAL REQUIREMENTS OF ALL APPLIANCES AND WATER HEATERS AND PROVIDE ACCORDINGLY. PROVIDE DEDICATED CIRCUITS FOR EACH UNIT, AND CUTOFF SWITCHES AND CONVENIENCE OUTLETS PER CODE REQUIREMENTS.

**APPLIANCE NOTE:**

VERIFY ELECTRICAL REQUIREMENTS OF ALL APPLIANCES AND WATER HEATERS AND PROVIDE ACCORDINGLY. PROVIDE DEDICATED CIRCUITS FOR EACH UNIT, AND CUTOFF SWITCHES AND CONVENIENCE OUTLETS PER CODE REQUIREMENTS.

**MECHANICAL SCHEDULE**

PLAN MARK	MODEL	REMARKS
CU-1	A/C CONDENSOR	CARRIER EQUIPMENT OR APPROVED EQUAL. SEER RATING 15 OR BETTER
AHU-1	3 TONS COOLING. ELECTRIC HEAT STRIPS.	CARRIER EQUIPMENT OR APPROVED EQUAL. SEER RATING 15 OR BETTER

NOTES: 700 S.F. CONDITIONED AREA MAIN HOUSE.

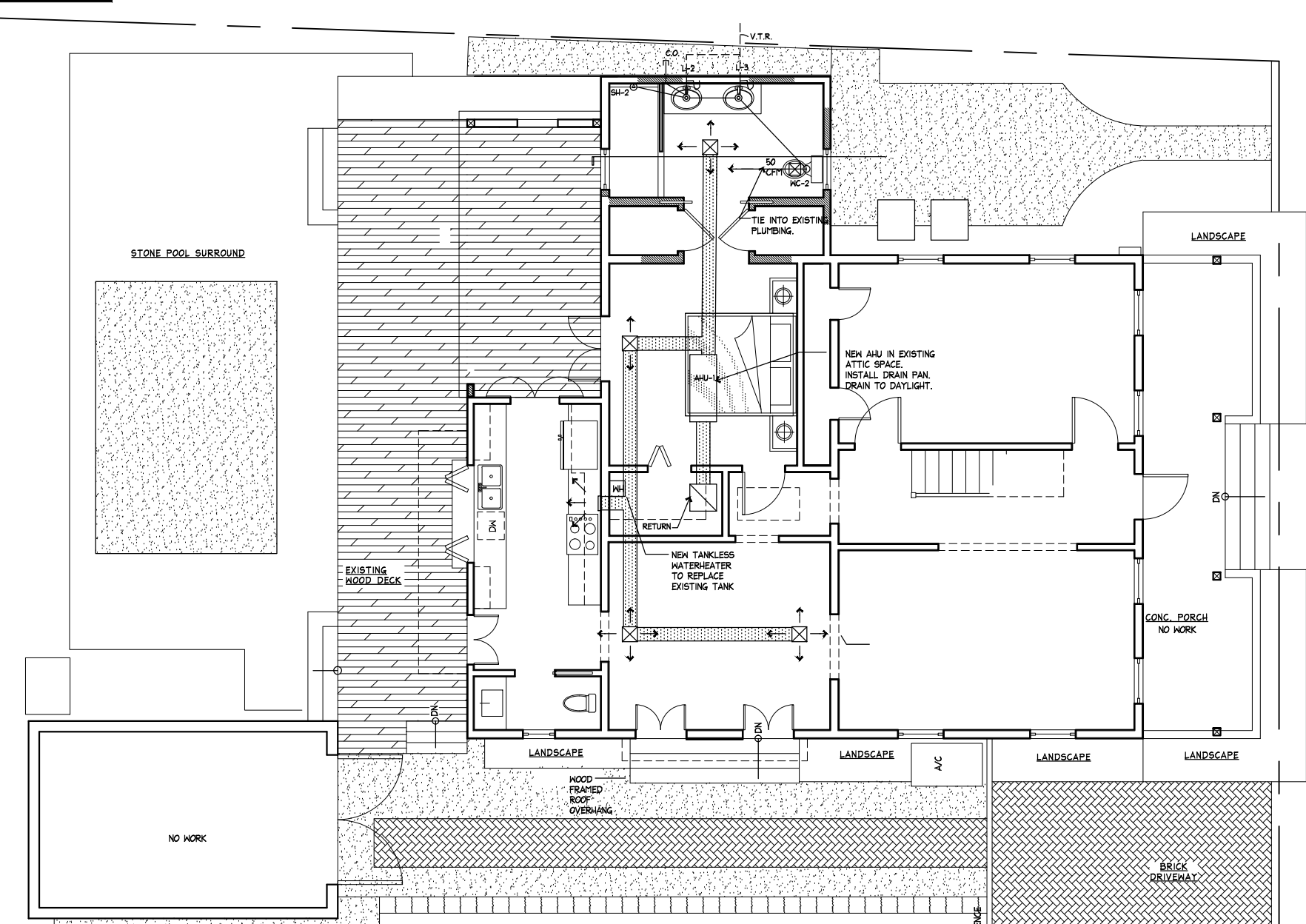

**PLUMBING / MECHANICAL PLAN**  
 SCALE: 1/4"=1'-0"

**KRABILL AND JONES RESIDENCE**  
 1415 NEWTON STREET  
 KEY WEST, FLORIDA, 33040

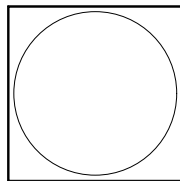

410 Angela Street  
 Key West, Florida 33040  
 Telephone (305) 296-1347  
 Facsimile (305) 296-2727  
 Florida License AAC002022

*Bender & Associates*  
**ARCHITECTS**  
 p.c.

Project No: 1526  
 MECHANICAL PLUMBING PLANS NOTES  
 Date: 10/01/15

**A9.1**  
 11 OF 13





# NOTICING

# Public Meeting Notice

The Historic Architectural Review Commission will hold a public hearing at 5:30 p.m., June 28, 2016 at Old City Hall, 510 Greene Street, Key West, Florida. The purpose of the hearing will be to consider a request for:

**NEW REAR PORCH WITH GABLE ROOF AND SIDE WALL. PARTIAL DEMOLITION OF REAR PORTION OF HOUSE INCLUDING SHED ROOF AND WALLS.**

**FOR- #1415 NEWTON STREET**

**Applicant – Bender And Associates**

**Application #H16-03-0044**

If you wish to see the application or have any questions, you may visit the Planning Department during regular office hours at 3140 Flagler Avenue, call 305-809-3975 or visit our website at [www.cityofkeywest-fl.gov](http://www.cityofkeywest-fl.gov).

**THIS NOTICE CAN NOT BE REMOVED FROM THE SITE UNTIL HARC FINAL DETERMINATION**

**ADA ASSISTANCE:** It is the policy of the City of Key West to comply with all requirements of the Americans with Disabilities Act (ADA). Please call the TTY number at 800-955-8771 or 800-955-8770 (Voice) or the ADA Coordinator at 305-809-3731 at least five business days in advance for sign language interpreters, assistive listening devices, or materials in accessible format.



**Public Meeting Notice**

NOTICE OF A PUBLIC MEETING  
CITY OF CHARLOTTE

FOR MORE INFORMATION, VISIT US AT [www.charlotte.gov](http://www.charlotte.gov) OR CALL US AT 704.375.2000.

# PROPERTY APPRAISER INFORMATION



**Scott P. Russell, CFA**  
**Property Appraiser**  
**Monroe County, Florida**

Key West (305) 292-3420  
Marathon (305) 289-2550  
Plantation Key (305) 852-7130

---

## Property Record Card -

**Maps are now launching the new map application version.**

Alternate Key: 1024180 Parcel ID: 00023390-000000

### Ownership Details

**Mailing Address:**

KRABILL MELISSA D  
1415 NEWTON ST  
KEY WEST, FL 33040-7027

**All Owners:**

JONES BARBARA R/S , KRABILL MELISSA D

### Property Details

**PC Code:** 01 - SINGLE FAMILY

**Millage Group:** 10KW

**Affordable Housing:** No

**Section-Township-Range:** 05-68-25

**Property Location:** 1415 NEWTON ST KEY WEST

**Legal Description:** KW BENJ ALBURY'S SUBD DIAGRAM I-389 LOT 8 SQR 1 TR 7 & NEWTON STREET HIATUS G48-260/261  
OR1134-2469D/C OR1205- 1311/23(TRUST) OR1347-1/8 PROB#95-49-CP-10 OR1349-1563/4R/S  
OR1364-1867/69EST OR1364-1870/71EST OR1424-2094/97F/J(LG)

**Click Map Image to open interactive viewer**



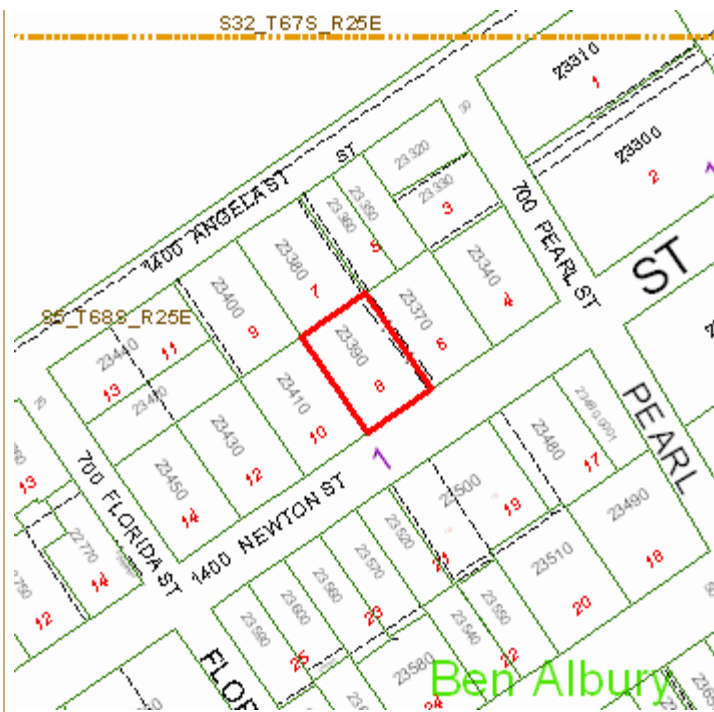

### Exemptions

Exemption	Amount
44 - ADDL HOMESTEAD	25,000.00
38 - HOMESTEAD R/S	25,000.00

### Land Details

Land Use Code	Frontage	Depth	Land Area
010D - RESIDENTIAL DRY	0	0	4,854.00 SF

## Building Summary

Number of Buildings: 1  
 Number of Commercial Buildings: 0  
 Total Living Area: 2323  
 Year Built: 1943

## Building 1 Details

Building Type R1	Condition G	Quality Grade 550
Effective Age 19	Perimeter 328	Depreciation % 26
Year Built 1943	Special Arch 0	Grnd Floor Area 2,323
Functional Obs 0	Economic Obs 0	

**Inclusions:** R1 includes 1 3-fixture bath and 1 kitchen.

Roof Type GABLE/HIP	Roof Cover METAL	Foundation WD CONC PADS
Heat 1 NONE	Heat 2 NONE	Bedrooms 3
Heat Src 1 NONE	Heat Src 2 NONE	

**Extra Features:**

2 Fix Bath 0	Vacuum 0
3 Fix Bath 1	Garbage Disposal 0
4 Fix Bath 0	Compactor 0
5 Fix Bath 0	Security 0
6 Fix Bath 0	Intercom 0
7 Fix Bath 0	Fireplaces 0
Extra Fix 0	Dishwasher 0

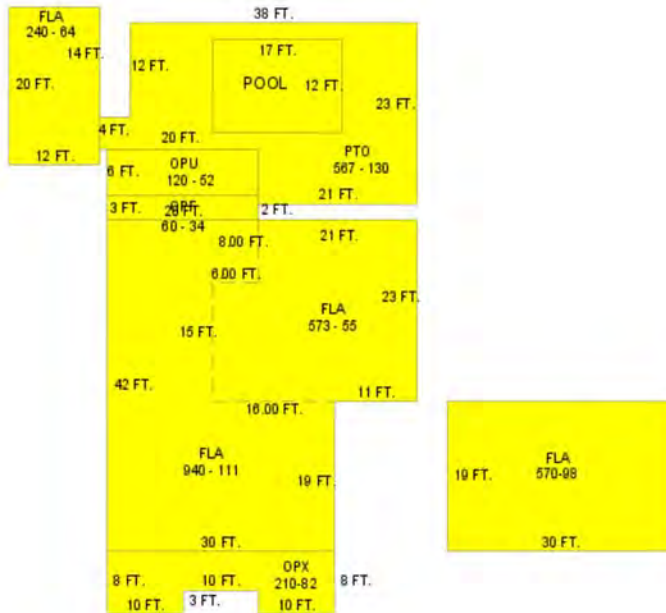

**Sections:**

Nbr	Type	Ext Wall	# Stories	Year Built	Attic A/C	Basement %	Finished Basement %	Area
0	FLA	1:WD FRAME	1	1987				240

0	<u>FLA</u>	12:ABOVE AVERAGE WOOD	1	1943					570
1	<u>FLA</u>	12:ABOVE AVERAGE WOOD	1	1943	N	Y	0.00	0.00	940
2	<u>OPX</u>		1	1943			0.00	0.00	210
3	<u>OPF</u>		1	1996			0.00	0.00	60
6	<u>FLA</u>	12:ABOVE AVERAGE WOOD	1	1996	N	N			573
7	<u>OPU</u>		1	1996					120
8	<u>PTO</u>		1	2004					567

## Misc Improvement Details

Nbr	Type	# Units	Length	Width	Year Built	Roll Year	Grade	Life
0	FN2:FENCES	354 SF	59	6	2015	2016	2	30
0	FN2:FENCES	80 SF	20	4	2015	2016	2	30
1	PT3:PATIO	122 SF	0	0	1949	1950	1	50
3	PT2:BRICK PATIO	220 SF	20	11	2015	2016	2	50
4	PO4:RES POOL	204 SF	17	12	2002	2003	5	50
5	PT3:PATIO	489 SF	0	0	1995	1996	2	50
6	FN2:FENCES	72 SF	6	12	2001	2002	2	30
7	RW2:RETAINING WALL	81 SF	54	2	1994	1995	4	50

## Appraiser Notes

2011-02-25 1997 HISTORIC FLORIDA KEYS FOUNDATION.DKRAUSE

2005 JUNE 02: INSPECTION REVEALED THAT UNIT "1415 B" AS DISPLAYED ON THE DOOR IS A SEPERATE QUARTERS FOR THE OWNER'S (M. KRABILL) MOTHER. THE UNIT HAS IT'S OWN KITCHEN, BATH AND ENTRANCE. - BKC

## Building Permits

Bldg Number	Date Issued	Date Completed	Amount	Description	Notes
10-1467	05/17/2009	02/25/2011	3,000		R&R SIDING ON EAST AND WEST SIDE OF HOUSE 500sf
13-4638	10/29/2013	02/10/2014	18,000		1200SF TEAR OFF CONCH SHINGLES INSTALL CDX , INSTALL METAL SHINGLES
15-0376	02/06/2015	03/08/2016	4,500		CONSTRUCT PICKET FENCE 6' TO 4' BETWEEN 1407 AND 1415 NEWTON
15-2469	07/02/2015	03/08/2016	2,116		REMOVE EXISTING CONCRETE ADN RED BRICK AND INSTALL OLD CHICAGO BRICK DRIVEWAY
B951612	05/01/1995	08/01/1995	500		REPL POST/REMOVE BLOCK
E951672	05/01/1995	08/01/1995	3,000		ELECTRIC WIRING
E951073	04/01/1995	08/01/1995	800		200 AMP SERVICE
P952905	09/01/1995	12/01/1995	1,600		REPLACE 3 FIXTURES
B952912	09/01/1995	12/01/1995	2,000		BUILD BATH RM WALL & SHWR
9601646	04/01/1996	09/01/1996	1,000		RENOVATIONS

9603005	07/01/1996	09/01/1996	11,000		POOL
9603728	09/01/1996	09/01/1996	1		ELECTRIC
1 9802869	10/06/1998	12/31/1998	1,500	Residential	INSTALL PINE FLOORING
04-0288	02/04/2004	10/14/2004	3,000		REPLASTER POOL

## Parcel Value History

Certified Roll Values.

[View Taxes for this Parcel.](#)

Roll Year	Total Bldg Value	Total Misc Improvement Value	Total Land Value	Total Just (Market) Value	Total Assessed Value	School Exempt Value	School Taxable Value
2015	261,221	21,764	434,267	717,252	356,568	25,000	373,671
2014	262,832	20,305	277,266	560,403	356,583	25,000	347,186
2013	242,614	20,824	257,922	521,360	342,689	25,000	334,611
2012	245,984	21,345	139,755	407,084	328,311	25,000	303,311
2011	245,984	21,864	193,485	461,333	333,953	25,000	327,583
2010	182,868	22,384	137,590	342,842	313,827	25,000	288,828
2009	203,745	22,905	376,323	602,973	380,937	25,000	355,937
2008	190,297	23,425	485,444	699,166	407,659	25,000	382,659
2007	253,983	18,999	800,983	1,073,965	506,431	25,000	481,431
2006	411,404	19,414	485,444	916,262	457,256	25,000	432,256
2005	464,331	19,826	339,811	823,968	425,568	25,000	400,568
2004	262,216	17,695	339,811	619,723	257,953	25,000	232,953
2003	262,216	18,111	150,488	430,816	253,144	25,000	228,144
2002	259,203	18,527	128,643	406,373	247,211	25,000	222,211
2001	245,655	24,462	128,643	398,760	243,070	25,000	218,070
2000	245,655	30,259	92,234	368,148	235,991	25,000	210,991
1999	216,867	27,249	92,234	336,350	229,787	25,000	204,787
1998	156,114	20,971	92,234	269,320	226,169	25,000	201,169
1997	142,340	19,555	82,525	244,419	222,389	25,000	197,389
1996	119,382	5,492	78,608	203,482	203,482	25,000	178,482
1995	95,185	4,672	78,608	178,464	178,464	0	178,464
1994	85,125	4,292	78,608	168,025	168,025	25,500	142,525
1993	83,821	1,880	78,608	164,309	164,309	25,500	138,809
1992	83,821	1,893	78,608	164,322	164,322	25,500	138,822
1991	83,821	1,906	78,608	164,335	164,335	25,000	139,335
1990	56,437	1,920	61,268	119,624	119,624	25,000	94,624
1989	51,306	1,757	60,112	113,175	113,175	25,000	88,175
1988	42,429	1,768	53,176	97,373	97,373	25,000	72,373
1987	37,746	1,780	31,674	71,200	71,200	25,000	46,200
1986	37,980	1,792	30,518	70,290	70,290	25,000	45,290
1985	36,987	1,804	18,466	57,257	57,257	25,000	32,257
1984	34,933	1,816	18,466	55,215	55,215	25,000	30,215

<b>1983</b>	34,933	1,828	18,466	55,227	55,227	25,000	30,227
<b>1982</b>	35,523	1,839	18,466	55,828	55,828	25,000	30,828

## Parcel Sales History

NOTE: Sales do not generally show up in our computer system until about two to three months after the date of sale. If a recent sale does not show up in this list, please allow more time for the sale record to be processed. Thank you for your patience and understanding.

Sale Date	Official Records Book/Page	Price	Instrument	Qualification
4/1/1995	1349 / 1563	232,500	<u>WD</u>	<u>Q</u>

This page has been visited 152,168 times.

Monroe County Property Appraiser  
 Scott P. Russell, CFA  
 P.O. Box 1176 Key West, FL 33041-1176