



COLLEGE  
OF THE  
FLORIDA KEYS

# Residential Complex Presentation

September 14, 2023

# CFK The City's Partner

## Educational Programs:

- ▶ 4 Baccalaureate Degrees
- ▶ Associate in Arts
- ▶ 10 Unique Associate Degrees in High Demand Career and Technical Education Fields
- ▶ 17 College Certificate Programs
- ▶ Emergency Medical Technician and Paramedic
- ▶ Institute for Public Safety - Law Enforcement and Corrections Academies
- ▶ CFK Academy Charter School
- ▶ Apprenticeships - Free to Residents
- ▶ Project ACCESS Program

## Additional Services:

- ▶ COVID-19 Vaccination Effort
- ▶ Staging Location Post-Hurricane
- ▶ Service Provider CareerSource South Florida
- ▶ Water Quality Monitoring
- ▶ Employs 150 Residents
- ▶ Trains Lifeguards
- ▶ Venue and Coach for Key West HS Swimming
- ▶ Coral Plantings and Monitoring
- ▶ Special Olympics

# Florida Statute 1013.40(4)

- ▶ CFK may construct dormitories for up to 340 student beds
- ▶ An additional 25 units for employees, educators, and first responders

# Lagoon Landing

## Existing Dormitory

- ▶ Opened in 2011
- ▶ 100 student bed facility
- ▶ Comprised of four- and five-bedroom suites
- ▶ Additional studio for the on-property manager
- ▶ Waitlist of potential residents since property opened
- ▶ 243 CFK applicants requested on-campus housing, but could not be accommodated
- ▶ 40 of those applicants secured off-campus housing
- ▶ Approximately 80% of Lagoon Landing residents work in our community



THE  
**COLLEGE**  
OF THE  
**FLORIDA KEYS**

# GROUND FLOOR

The ground floor will include 48 covered parking spaces, a lobby with security, dining hall, and outdoor patio.



THE COLLEGE OF THE FLORIDA KEYS

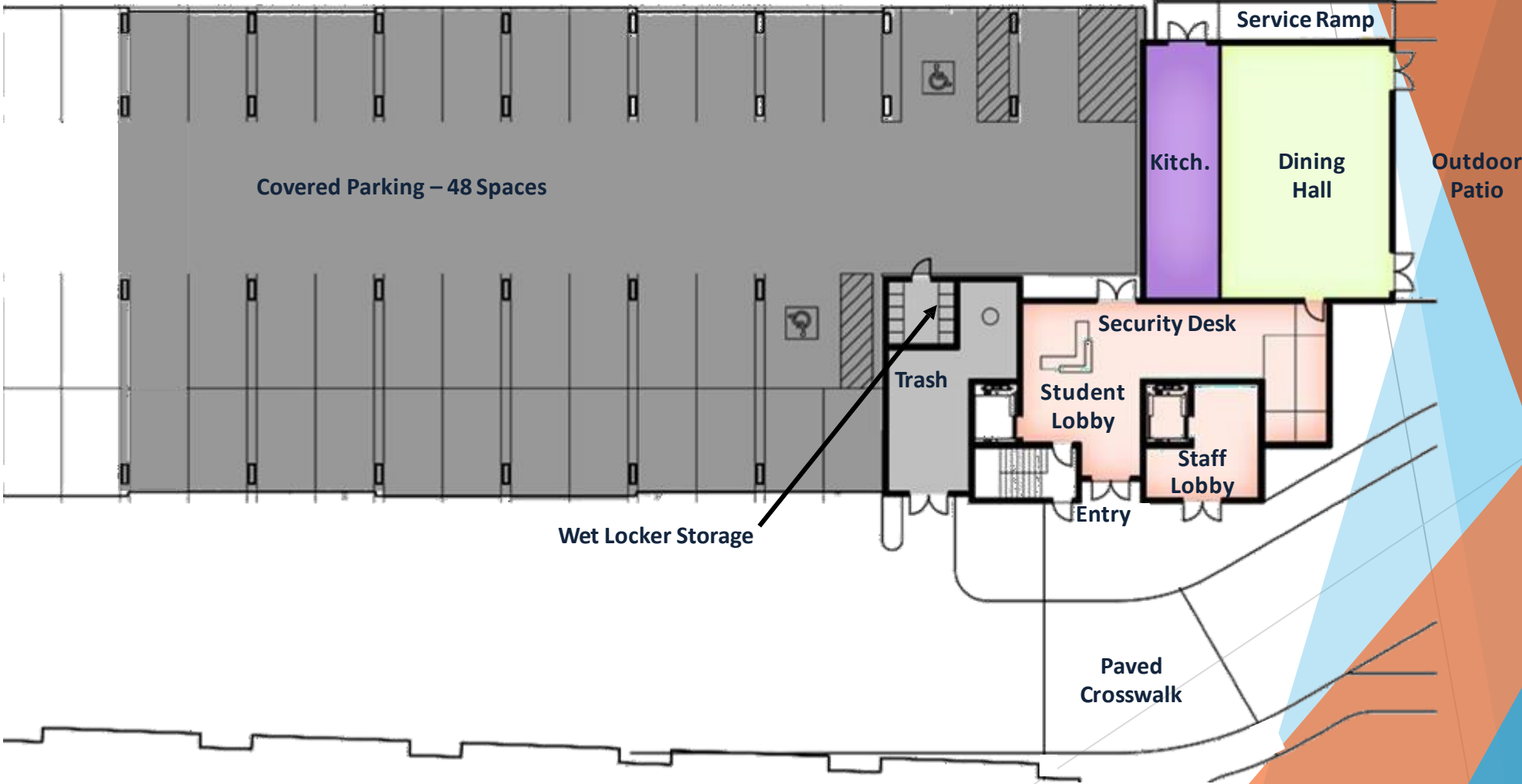

## 2<sup>ND</sup>, 3<sup>RD</sup> and 4<sup>TH</sup> FLOOR PLAN - STUDENT SUITES



THE  
COLLEGE  
OF THE  
FLORIDA KEYS

The second, third, and fourth floors will include at least eight four-bedroom/two-bathroom suites, a lounge, and a resident assistant (RA) unit. One floor will house the laundry facility. Floors two, three, and four are expected to accommodate over 200 students.

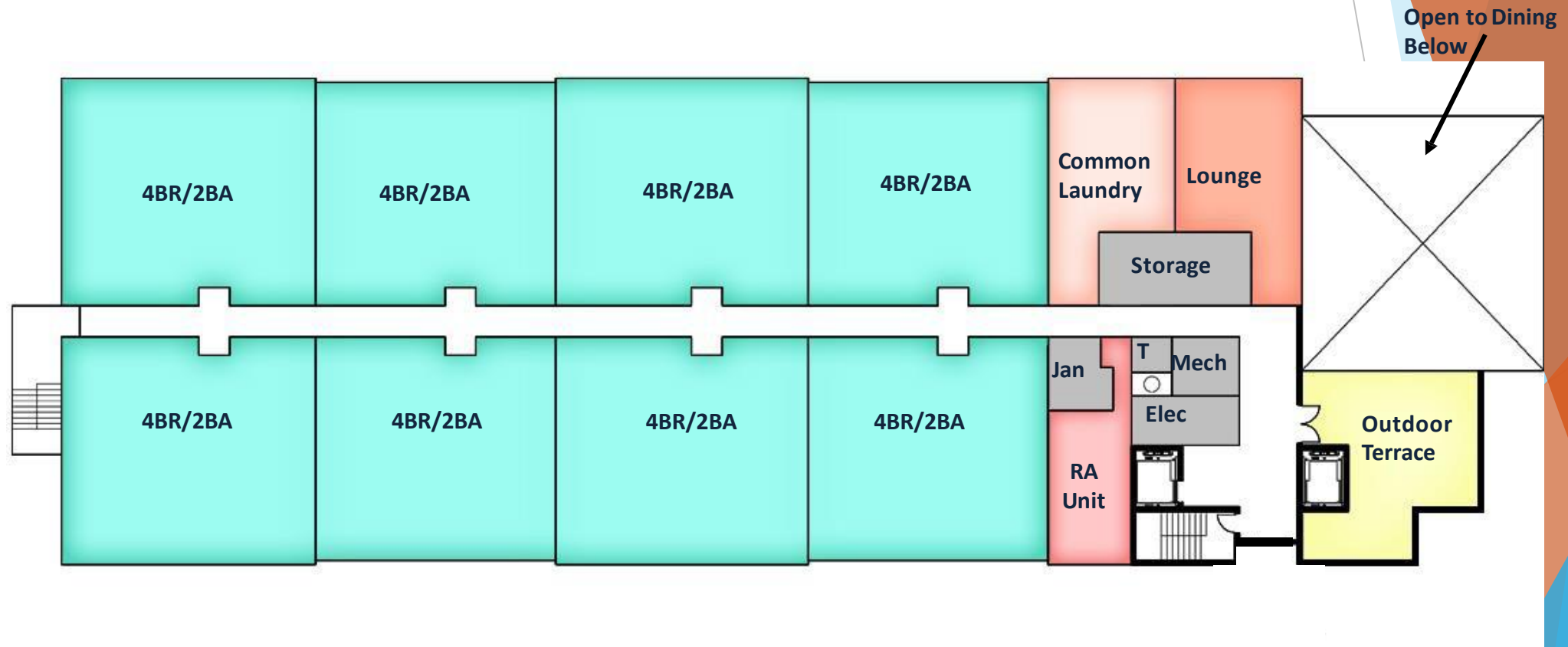

# 5<sup>TH</sup> FLOOR PLAN - EMPLOYEE SUITES



THE  
COLLEGE  
OF THE  
FLORIDA KEYS

The fifth floor will include 25 employee units with two-bedroom/one-bathroom, one-bedroom/one-bathroom, and studio options. Employees will have a designated outdoor terrace and lobby.

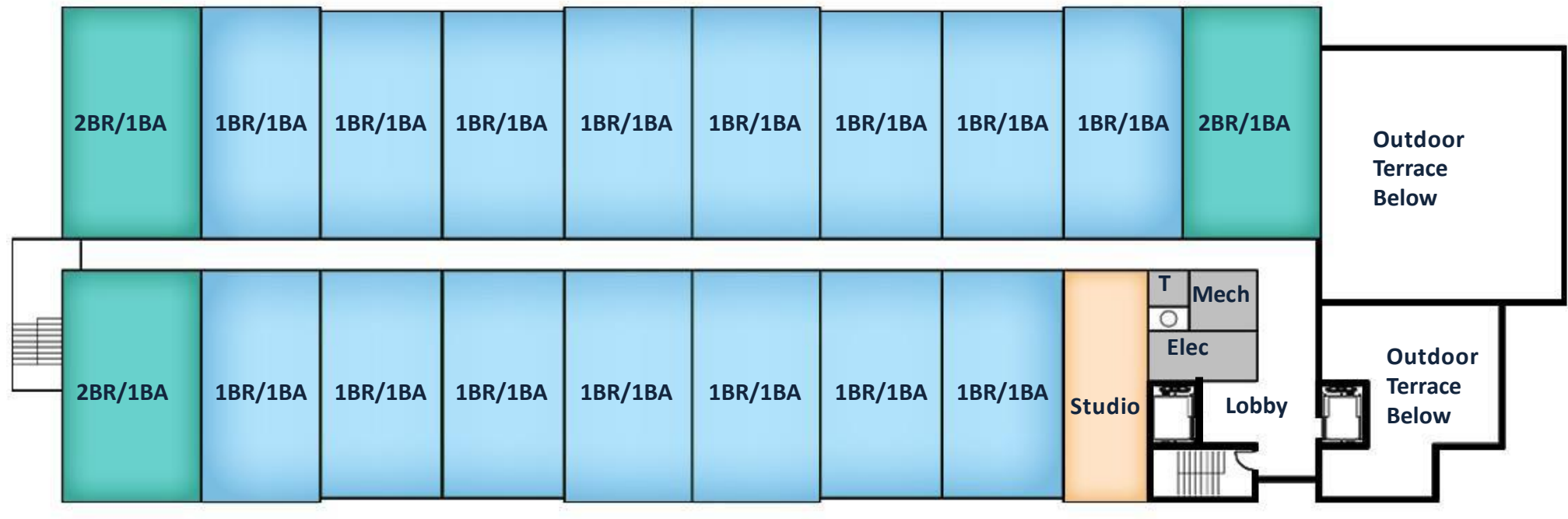

*\*The rendering above does not reflect the the total employee housing units that will be included in the final design.*



# EXAMPLE STUDENT SUITES

An example of a double occupancy four-bedroom and two-bathroom student suite.



THE  
COLLEGE  
OF THE  
FLORIDA KEYS



# EXAMPLE EMPLOYEE HOUSING UNITS

An example of the employee housing units. The fifth floor will house 25 employee units for educators and first responders.



THE COLLEGE OF THE FLORIDA KEYS

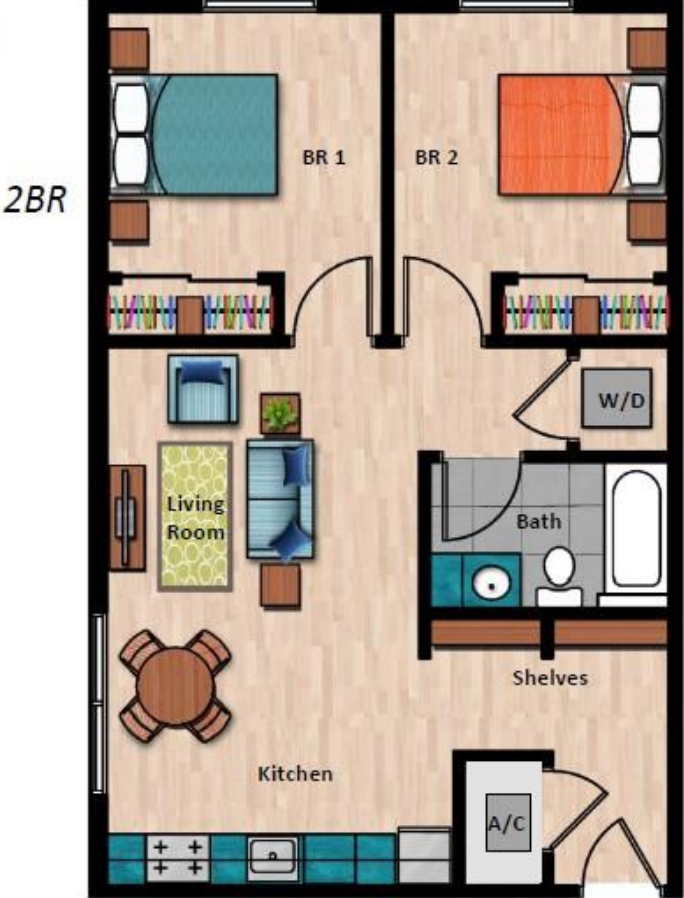
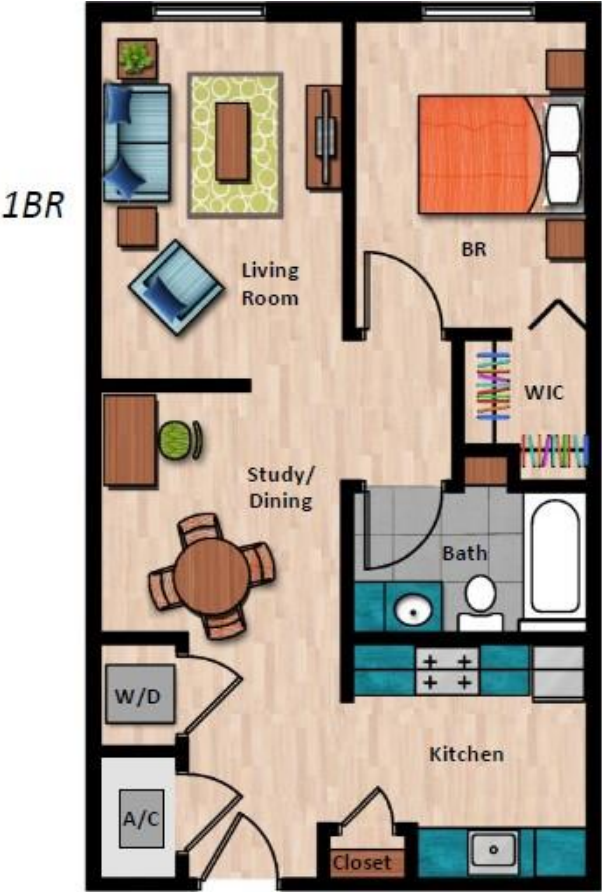
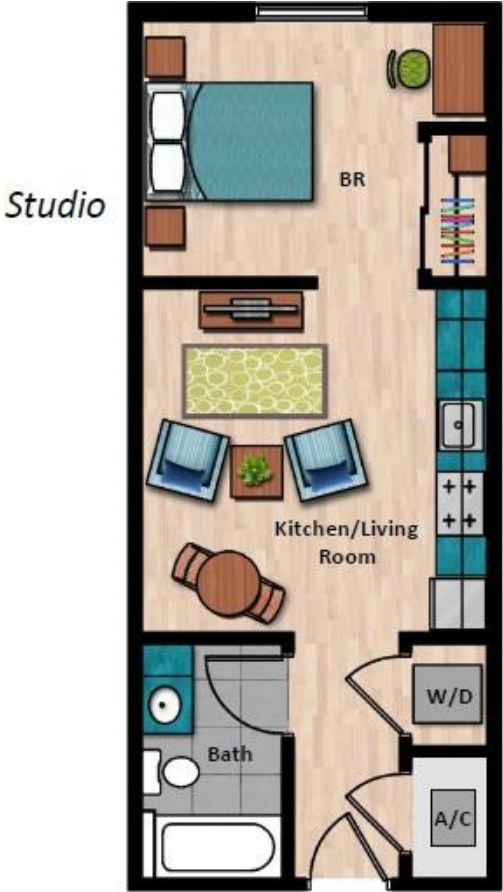

# What Does CFK need from the City?

The College of the Florida Keys (“CFK”), pursuant to Section 380.0666, F.S., is requesting five million dollars (\$5,000,000.00) from the Monroe County Land Authority (“MCLA”) for CFK’s construction of at least twenty-five (25) affordable workforce housing units for CFK employees, or when available and not provided to employees, Monroe County’s workforce (the “Project”). The Project is to be developed on CFK’s property located at 5901 College Road, Key West, Florida 33040, bearing Property ID No. 00072080-000900 (the “Property”).



For additional information contact:  
Dr. Jonathan Gueverra  
President & C.E.O.  
[Jonathan.Gueverra@cfk.edu](mailto:Jonathan.Gueverra@cfk.edu)  
305-809-3204