

NOTE TO BIDDER: Use preferably BLACK ink for completing this Proposal form.

**PROPOSAL**

To: The City of Key West  
Address: 3126 Flagler Street, Key West, Florida 33041  
Project Title: Cemetery Mausoleums

Bidder's contact person for additional information on this Proposal:

Company Name: Matt DeLuca Douglas N. Higgins, Inc.  
Contact Name & Telephone #: Matt DeLuca (941) 465-8358  
Email Address: mdeluca@mckennacontracting.com

BIDDER'S DECLARATION AND UNDERSTANDING

The undersigned, hereinafter called the Bidder, declares that the only persons or parties interested in this Proposal are those named herein, that this Proposal is, in all respects, fair and without fraud, that it is made without collusion with any official of the Owner, and that the Proposal is made without any connection or collusion with any person submitting another Proposal on this Contract.

The Bidder further declares that he has carefully examined the Contract Documents for the construction of the project, that he has personally inspected the site, that he has satisfied himself as to the quantities involved, including materials and equipment, and conditions of work involved, including the fact that the description of the quantities of work and materials, as included herein, is brief and is intended only to indicate the general nature of the work and to identify the said quantities with the detailed requirements of the Contract Documents, and that this Proposal is made according to the provisions and under the terms of the Contract Documents, which Documents are hereby made a part of this Proposal.

The Bidder further agrees that he has exercised his own judgment regarding the interpretation of subsurface information and has utilized all data which he believes pertinent from the Engineer, Owner, and other sources in arriving at his conclusions.

CONTRACT EXECUTION AND BONDS

The Bidder agrees that if this Proposal is accepted, he will, within 10 days, not including Sundays and legal holidays, after Notice of Award, sign the Contract in the form annexed hereto, and will at that time, deliver to the Owner examples of the Performance Bond and Payment Bond required herein, and evidence of holding required licenses and certificates, and will, to the extent of his Proposal, furnish all machinery, tools, apparatus, and other means of construction and do the work and furnish all the materials necessary to complete all work as specified or indicated in the Contract Documents.

CERTIFICATES OF INSURANCE

Bidder agrees to furnish the Owner, before commencing the work under this Contract, the certificates of insurance as specified in these Documents.

START OF CONSTRUCTION AND CONTRACT COMPLETION TIME

The Bidder further agrees to begin work within 10 calendar days after the date of the Notice to proceed and to complete the project, in all respects within 180 calendar days after the date of the Notice to Proceed.

LIQUIDATED DAMAGES

In the event the Bidder is awarded the Contract and shall fail to complete the work within the time limit or extended time limit agreed upon, as more particularly set forth in the Contract Documents, liquidated damages shall be paid to the Owner at the rate of \$500 per day plus the cost of engineering services for all work awarded until the work has been satisfactorily completed as provided by the Contract Documents. Sundays and legal holidays shall be excluded in determining days in default.

ADDENDA

The Bidder hereby acknowledges that he has received Addenda No's. 1, \_\_\_\_\_, \_\_\_\_\_, \_\_\_\_\_, \_\_\_\_\_, \_\_\_\_\_, \_\_\_\_\_, \_\_\_\_\_, \_\_\_\_\_, \_\_\_\_\_, \_\_\_\_\_ (Bidder shall insert No. of each Addendum received) and agrees that all addenda issued are hereby made part of the Contract Documents, and the Bidder further agrees that his Proposal(s) includes all impacts resulting from said addenda.

SALES AND USE TAXES

The Bidder agrees that all federal, state, and local sales and use taxes are included in the stated bid prices for the work.

LUMP SUM ITEMS

The Bidder further proposes to accept as full payment for the work proposed herein the amounts computed under the provisions of the Contract Documents and based on the following lump sum amounts. The Bidder agrees that the lump sum represent a true measure of the labor and materials required to perform the work, including all allowances for overhead and profit for each type and unit of work called for in these Contract Documents.



THE CITY OF KEY WEST

Post Office Box 1409 Key West, FL 33041-1409 (305) 809-3867

---

**ADDENDUM # 1**

**ITB – 13-002**

**CONSTRUCT KEY WEST CEMETERY MAUSOLEUMS – CE 1003**

December 21, 2012

To All Bidders,

The following changes and additions are hereby made a part of Project number CE 1003, Construct Key West Cemetery Mausoleums, as fully and completely as if the same were fully set forth therein:

1.) In the Scope of Work on page 66 Part 1 Item 1.1 Contractors Responsibilities please **delete**:

“A 7' -1 0" sidewalk shall be installed along the front of the crypts, and a 10' -0" sidewalk in front of the niches” and **replace with**:

Install a 10 foot long x 5'8" wide sidewalk on the south side of the mausoleums

Install a 61 foot long (the total length of the structure) x 10 foot wide sidewalk

All sidewalks are to be 4" thick 3000 psi concrete with broom finish

2.) Crypts shall include venting in accordance with the 2010 Florida Building Code

Please see two (2) attachments of Schematic Venting Diagrams for informational purposes:

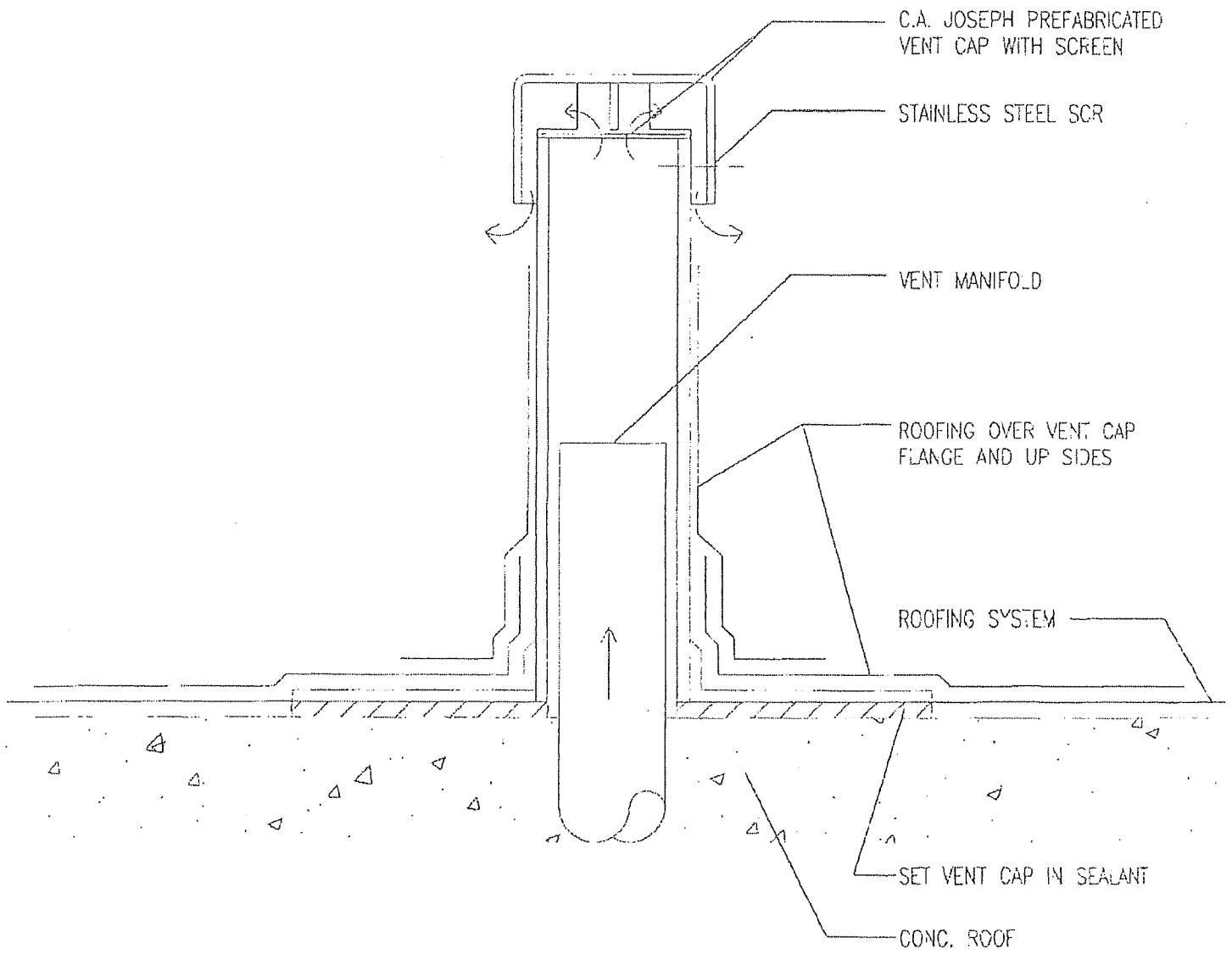

<p>SUBJECT:</p> <p>CRYPT VENT DETAIL</p>		
--	--	--

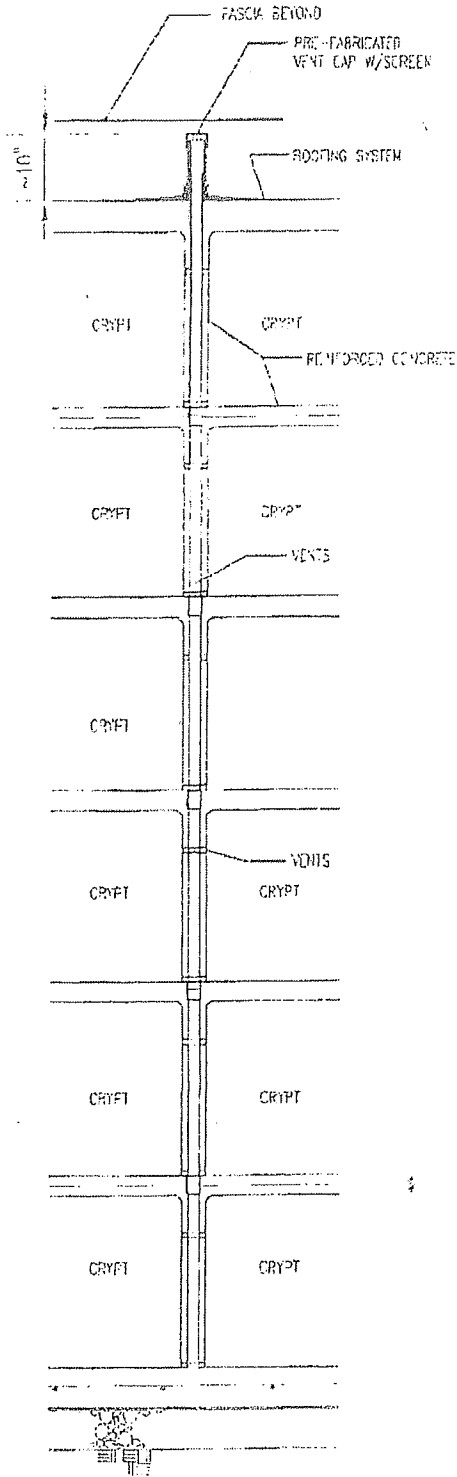

TYPICAL DETAIL OF CRYPT VENTING

Wall  
 Section  
 Sheet  
 1 / 1

Mausoleum  
 A Typical Vent  
 Detail For:

All Bidders shall acknowledge receipt and acceptance of this Addendum No. 1 by acknowledging Addendum in their proposal or by submitting the addendum with the bid package. Bids submitted without acknowledgement or without this Addendum may be considered non-responsive.

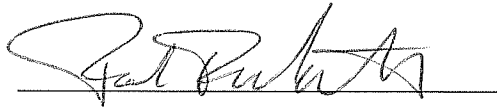

**Signature**

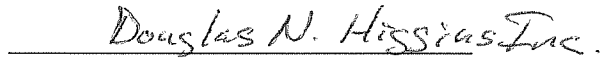

**Name of Business**

Performance and Payment Bonds

1. For First \$500,000 Worth of Construction Per / \$1,000 of Construction

1 EA \$ 4,700.00 \_\_\_\_\_ \$ 4,700.00

2. Mobilization and Demobilization, (includes, General & Supplementary Conditions)

1 LS \$ 39,000.00 \_\_\_\_\_ \$ 39,000.00

3. Signed & Sealed Drawings (includes specifications, Certified AutoCAD As-builts)

1 LS \$ 21,000.00 \_\_\_\_\_ \$ 21,000.00

4. Pour-in Place Mausoleum (Includes all labor, equipment & materials)

1 LS \$ 304,400.00 \_\_\_\_\_ \$ 304,400.00

**TOTAL OF ALL EXTENDED LINE ITEMS LISTED ABOVE:**

Total of lump sum items 1 - 4 \$ 369,100.00 \_\_\_\_\_

Three Hundred Sixty Nine Thousand One Hundred Dollars & 00 Cents  
(amount written in words)

**NOTE: THIS TOTAL WILL BE THE BASIS FOR EVALUATING LOW BIDDER AND BASIS OF AWARD**

**PROPOSAL CONTINUES ON NEXT PAGE**

**ADD /ALTERNATE (In-Lieu of Item # 4)**

5. Pre -Fabricated Mausoleum (Includes all labor, equipment & materials, Signed & Sealed Drawings Specifications, Certified AutoCAD As-builts)

1      LS      \$ 321,700.<sup>00</sup>      \$ 321,700.<sup>00</sup>

**TOTAL OF ALL EXTENDED LINE ITEMS 1, 2, 3 & 5 LISTED ABOVE:**

Total of lump sum items 1, 2, 3 & 5      \$ 386,400.<sup>00</sup>

Three Hundred Eight Six Thousand Four Hundred Dollars & ϕ Cents  
(amount written in words)

**NOTE:** THIS TOTAL WILL BE THE BASIS FOR EVALUATING LOW BIDDER AND BASIS OF AWARD

Payment for materials and equipment authorized by the ENGINEER in a written Change Order but not listed in the above Proposal will be provided at the suppliers invoice plus 10 %.



List items to be performed by CONTRACTOR's own forces and the estimated total cost of these items.  
(Use additional sheets if necessary.)

Project Management

Site Work

Utilities Connections

\$107,000.00

SUBCONTRACTORS

The Bidder further proposes that the following subcontracting firms or businesses will be awarded subcontracts for the following portions of the work in the event that the Bidder is awarded the Contract:

Bella Construction of Key West Inc.  
Name

111 US Hwy 1 Box 110, Key West, FL, 33040  
Street City State Zip

Dan Butcher Roofing  
Name

1620 SW Beverly Terrace, Stuart, FL, 34997  
Street City State Zip

Mario Ferazzoli + Son Inc.  
Name

419 NE 4th Ave, Boynton Beach, FL, 33435  
Street City State Zip

\_\_\_\_\_  
Name

\_\_\_\_\_  
Street City State Zip

SURETY

Hartford Accident & Indemnity Co. whose address is  
One Hartford Plaza T-4, Hartford, CT, 06155  
Street City State Zip

BIDDER

The name of the Bidder submitting this Proposal is

Douglas N. Higgins, Inc. doing business at  
3390 Travis Pointe Rd. Suite A, Ann Arbor, MI, 48108  
Street City State Zip

which is the address to which all communications concerned with this Proposal and with the Contract shall be sent.

The names of the principal officers of the corporation submitting this Proposal, or of the partnership, or of all persons interested in this Proposal as principals are as follows:

Douglas N. Higgins - President

R. Suzanne Hawker - Secretary / Treasurer

Daniel Higgins, William Higgins, James Sweet & Kelly

Wilkie - Vice-President

If Sole Proprietor or Partnership

IN WITNESS hereto the undersigned has set his (its) hand this \_\_\_\_\_ day of \_\_\_\_\_ 2013.

\_\_\_\_\_  
Signature of Bidder

\_\_\_\_\_  
Title

If Corporation

IN WITNESS WHEREOF the undersigned corporation has caused this instrument to be executed and its seal affixed by its duly authorized officers this 9 day of January 2013.

(SEAL)

Douglas N. Higgins, Inc.  
Name of Corporation

By Kelly A. Wilkie

Title Vice-President

Attest R. Suzanne Hawker  
Secretary

EXPERIENCE OF BIDDER

The Bidder states that he is an experienced CONTRACTOR and has completed similar projects within the last 5 years.

(List similar projects, with types, names of OWNERS, construction costs, ENGINEERS, and references with phone numbers. Use additional sheets if necessary.)

- See Attached -

\*\*\*\*\*

EXPERIENCE STATEMENT - SOUTHWEST DIVISION

<p><b>Project Name:</b> Pump Station 312.29 &amp; 312.41 Refurbishment</p> <p><b>Owner - Address - Project Manager - Phone:</b>                  Collier County Public Utilities                  3339 Tamiami Trail E., Ste. 303                  Naples, FL 34112                  Zamira Del Toro, Project Mgr.                  239-252-6279</p> <p><b>Engineer - Address - Phone:</b>                  Tetra Tech, Inc.                  10600 Chevrolet Way, Ste. 300                  Estero, FL 33928                  Danny Nelson, P.E.                  239-390-1467</p> <p><b>Contract Date:</b> August 23, 2011  <b>Final Contract Amount:</b> \$267,222.12  <b>Completion Date:</b> April 25, 2012</p> <p><b>Project Description:</b>                  PS 312.29 - Refurbishment of existing PS 312.29 to install new HDPE discharge piping, new check and plug valves, new pumps and pH probe. Also amended existing electrical control panels to allow for new components. New curbs, stone, &amp; landscaping installed.                  PS 312.41 - Refurbishment of existing PS 312.41 to install new HDPE discharge piping, check and plug valves, pumps, electrical control panels, generator with ATS, new telemetry along with new lining in pump station. Privacy slats were also installed in existing fence along with new stone landscaping.</p>	<p><b>Project Name:</b> Hendry County - Construction of CR 78 Phase 1A &amp; 1B Drainage Improvements</p> <p><b>Owner - Address - Project Manager - Phone:</b>                  Hendry County Board of County Comm.                  P.O. Box 1607                  99 East Cowboy Way                  LaBelle, FL 33975                  Shane Parker, PE                  (863) 675-5222</p> <p><b>Engineer - Address - Phone:</b>                  Johnson Engineering                  251 W. Hickpochee Ave.                  LaBelle, FL 33935                  James. V. Lofton, Jr.                  (863) 612-0594</p> <p><b>Contract Date:</b> December 1, 2011  <b>Final Contract Amount:</b> \$785,516.97  <b>Completion Date:</b> July 10, 2012</p> <p><b>Project Description:</b>                  Remove &amp; install roadway concrete box culverts and headwalls. Installed concrete sediment basin &amp; ditch block, steel sheet pile, grade work for slopes and relocation of swales and ditches, remove and replace guardrails and asphalt. Install pedestrian picket railing, rip-rap, drainage pipe, sod, signage and striping.</p>
<p><b>Project Name:</b> Traditions, Golf Residences and Villas at Grey Oaks</p> <p><b>Owner - Address - Project Manager - Phone:</b>                  CCC Traditions, LLC                  135 San Lorenzo Ave.                  Coral Gables, FL 33146</p> <p><b>Engineer - Address - Phone:</b>                  Peninsula Engineering                  2800 Golden Gate Pkwy.                  Naples, FL 34105                  C.J Brown                  239-262-2600</p> <p><b>Contract Date:</b> January 1, 2012  <b>Final Contract Amount:</b> \$363,596.00  <b>Completion Date:</b> July 13, 2012</p> <p><b>Project Description:</b>                  Modification of existing sanitary sewer system from single family home layout to multi-family home layout, new city water system, modification of existing drainage system.</p>	<p><b>Project Name:</b> Michigan Street Sidewalk Project</p> <p><b>Owner - Address - Project Manager - Phone:</b>                  City of Bonita Springs                  9101 Bonita Beach Road                  Bonita Springs, FL 34135                  (239) 949-6262                  David Liccardi</p> <p><b>Engineer - Address - Phone:</b>                  Lake Hickory Ventures, Inc.                  22210 Fairmont Ct.                  Estero, FL 33928                  (239) 898-4008</p> <p><b>Contract Date:</b> August 15, 2012  <b>Final Contract Amount:</b> \$175,734.00  <b>Completion Date:</b> September 28, 2012</p> <p><b>Project Description:</b>                  Furnish and installed Portland Cement Concrete sidewalk along the west side of Michigan Street from Bonita Beach Road to Pennsylvania Ave. Project consisted of 2220 LF of sidewalk, 15", 24", and 30" reinforced concrete pipe, mitered end sections, yard drains, vertical headwal, FDOT approved railing, fill material, sod, signage, striping, and various incidental items.</p>

EXPERIENCE STATEMENT - SOUTHWEST DIVISION

<p><b>Project Name:</b> Wyndemere Country Club Remove/Install 43 Fire Hydrants &amp; Valves</p> <p><b>Owner - Address - Project Manager - Phone:</b>                  Collier County Water Distribution                  4370 Mercantile Ave.                  Naples, FL 34104                  Pam Libby                  239-252-6239</p> <p><b>Engineer - Address - Phone:</b>                  N/A</p> <p><b>Contract Date:</b> September 5, 2011  <b>Final Contract Amount:</b> \$98,350.00  <b>Completion Date:</b> November 21, 2011</p> <p><b>Project Description:</b>                  Remove/Install 43 Fire Hydrants &amp; Valves                  Remove/Install 3 Inline Valves                  Install 1 new Inline Valves</p>	<p><b>Project Name:</b> NCWRF Compliance Assurance</p> <p><b>Owner - Address - Project Manager - Phone:</b>                  Collier County Public Utilities                  3301 E. Tamiami Trail                  Naples, FL 34112                  Peter Schait, PMP</p> <p><b>Engineer - Address - Phone:</b>                  Hole Montes, Inc.                  950 Encore Way                  Naples, FL 34110                  Clifford Pepper, P.E.                  (239) 254-2000</p> <p><b>Contract Date:</b> November 6, 2009  <b>Final Contract Amount:</b> \$8,683,000.00  <b>Completion Date:</b> November 23, 2011</p> <p><b>Project Description:</b>                  Upgrade to existing odor control system. Installation of 4 new odor control units. Construction of two HDPE lined water storage ponds. Repairs and reshaping of existing ponds. Upgrade to existing MLE Aeration basins including fine bubble diffuser systems, centrifugal blower and odor control covers. Stormwater upgrades throughout site including ponds and swales. Upgrades and modifications to existing chemical supply systems</p>
<p><b>Project Name:</b> Vanderbilt Beach MSTU, Gulf Shore Drive Utility Relocate</p> <p><b>Owner - Address - Project Manager - Phone:</b>                  Collier County Public Utilities                  3339 Tamiami Trail E., Ste. 303                  Naples, FL 34112                  Mark Sunyak, P.E. (Project Manager)</p> <p><b>Engineer - Address - Phone:</b>                  Malcolm Pirnie                  4315 Metro Pkwy, Ste. 520                  Ft. Myers, FL 33916</p> <p><b>Contract Date:</b> November 28, 2011  <b>Final Contract Amount:</b> \$72,778.50  <b>Completion Date:</b> January 27, 2012</p> <p><b>Project Description:</b></p>	<p><b>Project Name:</b> Bella Terra - Replace Existing Irrigation Main</p> <p><b>Owner - Address - Project Manager - Phone:</b>                  CCC Traditions, LLC                  135 San Lorenzo Ave.                  Coral Gables, FL 33146</p> <p><b>Engineer - Address - Phone:</b>                  Peninsula Engineering                  2600 Golden Gate Pkwy.                  Naples, FL 34105</p> <p><b>Contract Date:</b> December 5, 2011  <b>Final Contract Amount:</b> \$108,712.18  <b>Completion Date:</b> January 18, 2012</p> <p><b>Project Description:</b></p>

EXPERIENCE STATEMENT - SOUTHWEST DIVISION

<p><b>Project Name:</b> Lakes Park Water Quality Improvements</p> <p><b>Owner - Address - Project Manager - Phone:</b>  Lee County Board of County Commissioners  P.O. Box 398  Fort Myers, FL 33902-0398  Anura Karuna-Muni  239-533-8131</p> <p><b>Engineer - Address - Phone:</b>  AIM Engineering &amp; Surveying, Inc.  5300 Lee Blvd.  Lehigh Acres, FL 33971  Lee Flynn, P.E.  239-332-4569</p> <p><b>Contract Date:</b> April 26, 2011  <b>Final Contract Amount:</b> \$487,985.00  <b>Completion Date:</b> October 30, 2011</p> <p><b>Project Description:</b>  Constructing two additional control structures (CS 4 and 5) to enhance current flow patterns and reduce stagnant zones at the north and south ends of the west lake. The two existing control structures (CS 1 and 5) were modified by installing slide gates to reduce flow through these structures. The project also involved clearing and grading of four existing spoil islands to create littoral shelves by the removal of exotics and spoil material and the planting of native wetland vegetation.</p>	<p><b>Project Name:</b> East Naples/Solana Road Pump Station Improvements</p> <p><b>Owner - Address - Project Manager - Phone:</b>  City of Naples - Public Utilities Division  380 Riverside Circle  Naples, FL 34102  Dave Graff  239-213-4716</p> <p><b>Engineer - Address - Phone:</b>  Tetra Tech  201 East Pine Street, Ste. 1000  Naples, FL 34102  Jennifer Woodall, P.E.  407-839-3955</p> <p><b>Contract Date:</b> March, 2010  <b>Final Contract Amount:</b> \$2,500,000.00  <b>Completion Date:</b> February, 2011</p> <p><b>Project Description:</b>  Replacement of high services pumps, installation of electrical rooms and roof modifications, VFD installation, 600kw generator installation as well as other mechanical, structural, electrical and instrumentation improvements at two booster stations.</p>
<p><b>Project Name:</b> NCWRF Repair 5 Sludge Presses</p> <p><b>Owner - Address - Project Manager - Phone:</b>  Collier County Board of County Commissioners  3301 East Tamiami Trail  Naples, FL 34112  Claude Nesbitt, Sr. Project Mgr.  239-252-8380</p> <p><b>Engineer - Address - Phone:</b>  Kornline-Sanderson Engineering Corp.  12 Holland Ave.  Peapack, NJ 07977-0257  Steven Lukacs  908-234-1000</p> <p><b>Contract Date:</b> July 15, 2010  <b>Final Contract Amount:</b> \$143,000.00  <b>Completion Date:</b> November 14, 2011</p> <p><b>Project Description:</b>  Install sludge presses at 1, 2, 3, 5 and 6</p>	<p><b>Project Name:</b> SCRWTP Chlorination Improvements</p> <p><b>Owner - Address - Project Manager - Phone:</b>  Collier County Public Utilities  3301 E. Tamiami Trail  Naples, FL 34112  Alicia Abbott, Project Manager  239-252-5344</p> <p><b>Engineer - Address - Phone:</b>  Tetra Tech  201 East Pine Street, Ste. 1000  Naples, FL 34102  Jennifer Woodall, P.E.  407-839-3955</p> <p><b>Contract Date:</b> June 17, 2011  <b>Final Contract Amount:</b> \$98,831.00  <b>Completion Date:</b> November 3, 2011</p> <p><b>Project Description:</b></p>
<p><b>Project Name:</b> NCWRF Deep Injection Well Mag Meter Replacement</p> <p><b>Owner - Address - Project Manager - Phone:</b>  Collier County Public Utilities  3339 Tamiami Trail E., Ste. 303  Naples, FL 34112  Craig J. Pager, Project Manager  239-252-2554</p> <p><b>Engineer - Address - Phone:</b>  N/A</p> <p><b>Contract Date:</b> January 10, 2011  <b>Final Contract Amount:</b> \$24,526.72  <b>Completion Date:</b> September 13, 2011</p> <p><b>Project Description:</b>  Remove and install NCWRF DIW Magnetic Flow Meters, electrical disconnection and reconnection, provided and installed 24 inch Mega-flange</p>	<p><b>Project Name:</b> (4) 8" Gravity Line Segment Replacement along Vanderbilt Drive</p> <p><b>Owner - Address - Project Manager - Phone:</b>  Collier County Public Utilities  3301 Tamiami Trail E.  Naples, FL 34112  James Sainvilus, Project Manager  239-252-4285</p> <p><b>Engineer - Address - Phone:</b>  N/A</p> <p><b>Contract Date:</b> August 16, 2011  <b>Final Contract Amount:</b> \$158,000.00  <b>Completion Date:</b> September 23, 2011</p> <p><b>Project Description:</b>  Four 8" point repairs on Vanderbilt Drive</p>



EXPERIENCE STATEMENT - SOUTHWEST DIVISION

<p><b>Project Name:</b> Immokalee &amp; Everglades Intersection Improvements</p> <p><b>Owner - Address - Project Manager - Phone:</b>                  Collier County Board of Commissioners                  3301 Tamiami Trail East                  Naples, FL 33412</p> <p><b>Engineer - Address - Phone:</b>                  Collier County TECM                  2885 Horseshoe Dr.                  Naples, FL 34109</p> <p><b>Contract Date:</b> August 2, 2010  <b>Final Contract Amount:</b> \$50,108.00  <b>Completion Date:</b> November 8, 2010  <b>Project Description:</b>                  Subcontract Agreement with Better Roads, Inc.</p>	<p><b>Project Name:</b> Popash Creek Preserve Improvements</p> <p><b>Owner - Address - Project Manager - Phone:</b>                  Lee County Board of County Commissioners                  P.O. Box 398                  Fort Myers, FL 33902-0398                  Anura Karuna-Muni 239-533-8131</p> <p><b>Engineer - Address - Phone:</b>                  T.Y. Lin International                  2400 First St., Ste. 200                  Fort Myers, FL 33901                  Richard White Jr., P.E.                  (239) 332-4846</p> <p><b>Contract Date:</b> December 14, 2010  <b>Final Contract Amount:</b> \$1,035,426.46  <b>Completion Date:</b> June 30, 2011  <b>Project Description:</b>                  Work at Popash Creek consisted of construction external berms on three sides of the 307 acre preserve, constructing some internal berms in the South area, lowering the existing east-west berm (south of the interceptor ditch), installing 36" and 48" RCP's, channel excavation as part of Lake 1, sand cement rip rap installation, rip rap installation, sheet piling, weir gate installation as well as other misc. storm improvements.</p>
<p><b>Project Name:</b> North County Water Reclamation Facility Flow Meter Replacement, Phase 2</p> <p><b>Owner - Address - Project Manager - Phone:</b>                  Collier County Board of County Commissioners                  3301 East Tamiami Trail                  Naples, FL 34112                  Claude Nesbitt, Sr. Project Mgr.                  239-252-8380</p> <p><b>Engineer - Address - Phone:</b>                  Hole Montes                  950 Encore Way                  Naples, FL 34110                  239-254-2000</p> <p><b>Contract Date:</b> May 21, 2010  <b>Final Contract Amount:</b> \$192,994.05  <b>Completion Date:</b> December 6, 2010  <b>Project Description:</b>                  Furnish and install EQ Tank                  Furnish and install OX Ditch</p>	<p><b>Project Name:</b> Lee/Hendry County Construction of Injection Well Surface Facilities</p> <p><b>Owner - Address - Project Manager - Phone:</b>                  Lee County Board of County Commissioners                  P.O. Box 398                  Fort Myers, FL 33902-0398                  Keith Howard, Solid Waste                  239-533-8917</p> <p><b>Engineer - Address - Phone:</b>                  MWH Americas, Inc.                  14311 Metropolis Ave., Ste. 101                  Fort Myers, FL 33912                  Gordon Kennedy                  239-236-0011</p> <p><b>Contract Date:</b> January 25, 2011  <b>Final Contract Amount:</b> \$1,455,900.09  <b>Completion Date:</b> November 15, 2011  <b>Project Description:</b>                  Construction of a 2 acre injectate Storage Pond, installation of double containment HDPE piping for transfer of leachate, installation of an injection well and monitoring well, installation of an annular pressure tank fed with nitrogen, installation of monitoring well pumps, transducers and appurtenances along with injectate transfer, self-priming, non-clog, horizontal pumps. Project also involved installation of all associated electrical and complicated instrumentation system to cater for the safe transfer of leachate from various storage ponds into the injection well.</p>

EXPERIENCE STATEMENT - SOUTHWEST DIVISION

<p><b>Project Name:</b> Mackle Park Phase 3 (A) Improvements</p> <p><b>Owner - Address - Project Manager - Phone:</b>                  City of Marco Island                  50 Bald Eagle Drive                  Marco Island, FL 34145</p> <p><b>Engineer - Address - Phone:</b>                  American Engineering Consultants of Marco Island, Inc.                  573 Bald Eagle Drive                  Marco Island, FL 34145                  (239) 394-1697</p> <p><b>Contract Date:</b> January 19, 2010  <b>Final Contract Amount:</b> \$240,100.00  <b>Completion Date:</b> April 30, 2010</p> <p><b>Project Description:</b>                  Park renovations to include: New asphalt walkway around lake, new bollard lighting, new lake fountain, new polygon shelter</p>	<p><b>Project Name:</b> Isle of Capri - Phase I Water Main Improvements</p> <p><b>Owner - Address - Project Manager - Phone:</b>                  Collier County Public Utilities                  3301 Tamiami Trail East                  Naples, FL 34112                  Diana Dueri                  239-252-4218</p> <p><b>Engineer - Address - Phone:</b>                  David Schmitt, P.E.                  Q. Grady Minor                  3800 Via Del Rey                  Bonita Springs, FL 34134                  239-947-1144</p> <p><b>Contract Date:</b> April 29, 2010  <b>Final Contract Amount:</b> \$906,080.33  <b>Completion Date:</b> January 2, 2011</p> <p><b>Project Description:</b>                  Installation of new water distribution pipeline that connects to the existing 12-inch water transmission main that goes into the Isles of Capri from Collier Blvd. Includes installation of approx. 4500 LF of 12" PVC and 4500 LF of 6" PVC. Work also involves installation of new service lines and cross connection devices at each service location, along with several new fire hydrants and road restoration.</p>
<p><b>Project Name:</b> Winterberry Drive &amp; South Heathwood Drive Water Main Improvements</p> <p><b>Owner - Address - Project Manager - Phone:</b>                  City of Marco Island                  50 Bald Eagle Drive                  Marco Island, FL 34145                  Timothy E. Pinter, P.E., Public Works Director                  239-389-5000</p> <p><b>Engineer - Address - Phone:</b>                  AECOM Technical Services, Inc.                  4415 Metro Parkway, Suite 404                  Fort Myers, FL 33916                  Alfred J. Mitti, P.E.                  239-278-7996</p> <p><b>Contract Date:</b> March 4, 2010  <b>Final Contract Amount:</b> \$130,881.37  <b>Completion Date:</b> October 29, 2010</p> <p><b>Project Description:</b>                  18" Interconnect to existing 36" ductile iron watermain</p>	<p><b>Project Name:</b> MPS 104 Reclaimed Water Main Supp</p> <p><b>Owner - Address - Project Manager - Phone:</b>                  Collier County Public Utilities                  3301 E. Tamiami Trail                  Naples, FL 34112                  Shanthi Sridhar                  239-252-4285</p> <p><b>Engineer - Address - Phone:</b>                  Greeley and Hansen                  1567 Hayley Lane, Suite 201                  Fort Myers, FL 33907                  Kevin Higginson, P.E.                  239-226-9660</p> <p><b>Contract Date:</b> April 27, 2011  <b>Final Contract Amount:</b> \$245,908.88  <b>Completion Date:</b> January 21, 2011</p> <p><b>Project Description:</b>                  Construction of Approx. 240 LF of 16 inch and 18 inch reclaimed water main and improvements to a wastewater pumping station, including one horizontal directional drill roadway crossing and all pipe, fittings, appurtenances, valves, connection to existing reclaimed water main, air release valves, surface restoration, testing, and placing new reclaimed water main and pumping station improvements in service.</p>

EXPERIENCE STATEMENT - SOUTHWEST DIVISION

<p><b>Project Name:</b> SCWTP Rehab Reactor #1</p> <p><b>Owner - Address - Project Manager - Phone:</b>                      Collier County Public Utilities Planning                      &amp; Project Management                      3301 East Tamiami Trail                      Naples, FL 34112                      (239) 252-4218</p> <p><b>Engineer - Address - Phone:</b>                      N/A</p> <p><b>Contract Date:</b> July 28, 2009  <b>Final Contract Amount:</b> \$97,400.00  <b>Completion Date:</b> December 3, 2009</p>	<p><b>Project Name:</b> Master Pump Station 302 Rehabilitation</p> <p><b>Owner - Address - Project Manager - Phone:</b>                      Collier County Public Utilities Planning                      &amp; Project Management                      3301 East Tamiami Trail                      Naples, FL 34112                      (239) 252-4218</p> <p><b>Engineer - Address - Phone:</b>                      Q. Grady Minor &amp; Associates, P.A.                      David Schmitt                      3800 Via Del Rey                      Bonita Springs, FL 34134</p> <p><b>Contract Date:</b> November 10, 2008  <b>Final Contract Amount:</b> \$2,011,347.57  <b>Completion Date:</b> April 30, 2010</p> <p><b>Project Description:</b>                      Rehabilitation of Pump Station 302                      Complete Tear out of existing pumps and piping. Installed 8 new 100 HP pumps and associated 30" piping. Bypassed sanitary pump station with a 30,000 GPM bypass system in in extreme tight conditions.</p>
<p><b>Project Name:</b> Magnolia Pond Drive Stormwater Improvements</p> <p><b>Owner - Address - Project Manager - Phone:</b>                      Collier County Stormwater Dept.                      2885 S. Horseshoe Drive                      Naples, FL 34104                      Val Prince                      (239) 252-5879</p> <p><b>Engineer - Address - Phone:</b>                      Q. Grady Minor &amp; Associates                      3800 Via Del Rey                      Bonita Springs, FL 34134                      David Schmitt, P.E.                      (239) 947-1144</p> <p><b>Contract Date:</b> June 29, 2009  <b>Final Contract Amount:</b> \$86,775.00  <b>Completion Date:</b> October 2, 2009</p>	<p><b>Project Name:</b> Year 4 Sewer Districts Wastewater Lift Stations - Phase One and Two</p> <p><b>Owner - Address - Project Manager - Phone:</b>                      Marco Island Utilities                      50 Bald Eagle Drive                      Marco Island, FL 34145                      James Miller, Public Works                      (239) 394-3880</p> <p><b>Engineer - Address - Phone:</b>                      Boyle Engineering Corp.                      4415 Metro Pkwy., Ste. 404                      Ft. Myers, FL 33916                      (239) 278-7996</p> <p><b>Contract Date:</b> May 20, 2008  <b>Final Contract Amount:</b> \$1,777,185.54  <b>Completion Date:</b> April 23, 2010</p> <p><b>Project Description:</b>                      Installed reinforced concrete wet wells, valve vaults, master manholes, hatch covers &amp; 12-inch sanitary sewer from master manholes to wet well for 19 lift stations.</p>
<p><b>Project Name:</b> Master Pump Station 101 Improvements</p> <p><b>Owner - Address - Project Manager - Phone:</b>                      Collier County Public Utilities                      3301 E. Tamiami Trail, Bldg. H                      Naples, FL 34112                      (239) 252-4285</p> <p><b>Engineer - Address - Phone:</b>                      Agnoli, Barber &amp; Brundage, Inc.                      7400 Tamiami Trail N., Ste. 200                      Naples, FL 34108                      (239) 597-3111</p> <p><b>Contract Date:</b> November 30, 2009  <b>Final Contract Amount:</b> \$147,534.62  <b>Completion Date:</b> August 6, 2010</p> <p><b>Project Description:</b>                      Install forcemain and generator at MPS 101</p>	<p><b>Project Name:</b> Port of the Islands Mechanical &amp; Electrical Work at Water Well No. 3</p> <p><b>Owner - Address - Project Manager - Phone:</b>                      Port of the Island Community Improvement District</p> <p><b>Engineer - Address - Phone:</b>                      Hole Montes, Inc.                      950 Encore Way                      Naples, FL 34110                      (239) 254-2000</p> <p><b>Contract Date:</b> December 21, 2009  <b>Final Contract Amount:</b> \$169,398.99  <b>Completion Date:</b> June 2, 2010</p> <p><b>Project Description:</b>                      Mechanical &amp; Electrical work associated with new water well No. 3, including new well pump, control valve, flow meter and telemetry connection to well No. 3 system.</p>

EXPERIENCE STATEMENT - SOUTHWEST DIVISION

<p><b>Project Name:</b> SCWRF Rehabilitation Piping Odor Control Modifications</p> <p><b>Owner - Address - Project Manager - Phone:</b> Collier County Public Utilities Engineering 3301 Tamiami Trail East, Building H Naples, Florida 34112 Vaughn Williams</p> <p><b>Engineer - Address - Phone:</b> Hole Montes 950 Encore Way Naples, Florida 34110 E. Joseph Goetz, Jr. 239-254-2000</p> <p><b>Contract Date:</b> November 21, 2005 <b>Final Contract Amount:</b> \$217,900.00 <b>Completion Date:</b> July 12, 2006</p>	<p><b>Project Name:</b> Michigan Street Drainage Improvements</p> <p><b>Owner - Address - Project Manager - Phone:</b> City of Bonita Springs 9101 Bonita Beach Road Bonita Springs, Florida 34135 239-949-6262</p> <p><b>Engineer - Address - Phone:</b> Q. Grady Minor &amp; Associates 3800 Via Del Rey Bonita Springs, Florida 34134 David Schmitt</p> <p><b>Contract Date:</b> September 1, 2005 <b>Final Contract Amount:</b> \$243,610.00 <b>Completion Date:</b></p>
<p><b>Project Name:</b> Richview Court Drainage Maintenance</p> <p><b>Owner - Address - Project Manager - Phone:</b> City of Bonita Springs Public Works Department 9101 Bonita Beach Road Bonita Springs, Florida 239-949-6243.</p> <p><b>Engineer - Address - Phone:</b> City of Bonita Springs Public Works Department</p> <p><b>Contract Date:</b> December 27, 2005 <b>Final Contract Amount:</b> \$29,333.50 <b>Completion Date:</b> January 30, 2006</p>	<p><b>Project Name:</b> I-75 and Allico Road Interchange Reconst.</p> <p><b>Owner - Address - Project Manager - Phone:</b> Florida Department of Transportation Tallahassee, Florida</p> <p><b>Engineer - Address - Phone:</b> Contractor: Engineer: Thomas Boyle Kiewit Southern 239-432-2732 450 Dividend Drive 16999 James Whitehead Road Peachtree City, Georgia Fort Myers, Florida 33912</p> <p><b>Contract Date:</b> October 5, 2005 <b>Final Contract Amount:</b> \$1,288,742.63 <b>Completion Date:</b> June 2007</p>
<p><b>Project Name:</b> Culvert Replacement in the River Oaks, Palm River Subdivision</p> <p><b>Owner - Address - Project Manager - Phone:</b> Collier County Stormwater Management 2885 Horseshoe Drive Naples, Florida 34104 Margaret Bishop</p> <p><b>Engineer - Address - Phone:</b> Collier County Stormwater Management</p> <p><b>Contract Date:</b> April 4, 2005 <b>Final Contract Amount:</b> \$576,642.50 <b>Completion Date:</b> July 8, 2005</p>	<p><b>Project Name:</b> Twin Lakes Interconnect</p> <p><b>Owner - Address - Project Manager - Phone:</b> Collier County Stormwater Management 2885 Horseshoe Drive Naples, Florida 34104 Gianfranco Nicolaci</p> <p><b>Engineer - Address - Phone:</b> Agnoli Barber &amp; Brundage, Inc. 7400 Tamiami Trail North, Suite 200 Naples, Florida 34108 Roger Sandrus</p> <p><b>Contract Date:</b> September 12, 2005 <b>Final Contract Amount:</b> \$750,120.76 <b>Completion Date:</b> March 1, 2006</p>

EXPERIENCE STATEMENT - SOUTHWEST DIVISION

<p><b>Project Name:</b> Pump Station 109 and 113 Improvements</p> <p><b>Owner - Address - Project Manager - Phone:</b>                  Collier County                  Public Utilities Engineering                  3301 Tamiami Trail East, Building H                  Sandy Sridhar</p> <p><b>Engineer - Address - Phone:</b>                  Q. Grady Minor &amp; Associates                  3800 Via Del Rey                  Bonita Springs, Florida 34134                  David Schmitt</p> <p><b>Contract Date:</b> February 8, 2006  <b>Final Contract Amount:</b> \$1,229,561.25  <b>Completion Date:</b> September 29, 2006</p>	<p><b>Project Name:</b> Marco Island Wastewater Treatment Plant Expansion - Phase 1 Improvements</p> <p><b>Owner - Address - Project Manager - Phone:</b>                  City of Marco Island                  50 Bald Eagle Drive                  Marco Island, FL 34145                  Mr. Bruce Weinstein                  239-389-5182</p> <p><b>Engineer - Address - Phone:</b>                  CDM                  9311 College Parkway                  Fort Myers, FL 33919                  Adam Soblenski                  239-437-9494</p> <p><b>Contract Date:</b> May 23, 2006  <b>Final Contract Amount:</b> \$9,787,283.47  <b>Completion Date:</b> January 17, 2007</p>
<p><b>Project Name:</b> Appurtenances For Wells RO 101N and 102N</p> <p><b>Owner - Address - Project Manager - Phone:</b>                  Collier County                  Public Utilities Engineering                  3301 Tamiami Trail East, Building H                  Naples, Florida 34112                  Peter Schall</p> <p><b>Engineer - Address - Phone:</b>                  Hazen &amp; Sawyer                  2101 Corporate Boulevard, Suite 301                  Boca Raton, Florida 33431                  Albert Muniz</p> <p><b>Contract Date:</b> May 24, 2005  <b>Final Contract Amount:</b> \$597,000.00  <b>Completion Date:</b> January 27, 2006  <b>Length of Contract:</b> 240 days  <b>Project Description:</b>                  This project was to install two complete wellhead facilities. The work included structural concrete, mechanical, electrical, fiber optic line connections, and I &amp; C. The raw water pipe size was greater than 12 inches.</p>	<p><b>Project Name:</b> Construction of Wells 35 &amp; 36</p> <p><b>Owner - Address - Project Manager - Phone:</b>                  Collier County                  Public Utilities Engineering                  3301 Tamiami Trail East, Building H                  Howard Brogdon</p> <p><b>Engineer - Address - Phone:</b>                  Camp Dresser &amp; McKee, Inc.                  9311 College Parkway, Suite 1                  Fort Myers, Florida 33919                  Adam Sobolewski                  239-432-9494</p> <p><b>Contract Date:</b> August 16, 2005  <b>Final Contract Amount:</b> \$998,980.97  <b>Completion Date:</b> January 30, 2006  <b>Length of Contract:</b> 120 days  <b>Project Description:</b>                  This project was to install two complete wellhead facilities and install over 1000 LF of 24" PVC Raw Water pipe. The work included structural concrete, mechanical, electrical, fiber optic line connections, ductbank, and I &amp; C.</p>
<p><b>Project Name:</b> 12th Avenue Interconnect Booster PS</p> <p><b>Owner - Address - Project Manager - Phone:</b>                  Collier County                  Public Utilities Engineering                  3301 Tamiami Trail East, Building H                  Naples, Florida 34112                  Peter Schall</p> <p><b>Engineer - Address - Phone:</b>                  Hazen and Sawyer                  1905 South 25th Street, Suite 103                  Fort Pierce, Florida 34947                  Albert Muniz</p> <p><b>Contract Date:</b> August 8, 2005  <b>Final Contract Amount:</b> \$1,083,000.00  <b>Completion Date:</b> October 31, 2006</p>	<p><b>Project Name:</b> NCWRF Rebuild filter Set 1 Clean and Paint Filter Beds</p> <p><b>Owner - Address - Project Manager - Phone:</b>                  Collier County                  Public Utilities Engineering Department                  3301 Tamiami Trail East, Building H                  Karen Guliani</p> <p><b>Engineer - Address - Phone:</b>                  Collier County                  Public Utilities Engineering Department                  3301 Tamiami Trail East, Building H                  Karen Guliani</p> <p><b>Contract Date:</b> March 1, 2005  <b>Final Contract Amount:</b> \$354,817.00  <b>Completion Date:</b> September 14, 2005</p>

EXPERIENCE STATEMENT - SOUTHWEST DIVISION

<p><b>Project Name:</b> Tigertail Sewer District Wastewater Collection System Expansion</p> <p><b>Owner - Address - Project Manager - Phone:</b> City of Marco Island 50 Bald Eagle Drive Marco Island, FL 34145 Mr. James Miller 239-389-5011</p> <p><b>Engineer - Address - Phone:</b> Boyle Engineering 4415 Metro Parkway, Suite 104 Fort Myers, FL 33916 Fred Miltl 239-278-7996</p> <p><b>Contract Date:</b> March 7, 2006 <b>Final Contract Amount:</b> \$2,920,703.33 <b>Completion Date:</b> December 21, 2006</p>	<p><b>Project Name:</b> Pads for MBR and Equipment</p> <p><b>Owner - Address - Project Manager - Phone:</b> City of Marco Island 50 Bald Eagle Drive Marco Island, FL 34145 Mr. Bruce Weinstein 239-389-5182</p> <p><b>Engineer - Address - Phone:</b> CDM 9311 College Parkway Fort Myers, FL 33919 Adam Soblenski 239-437-9494</p> <p><b>Contract Date:</b> March 13, 2006 <b>Final Contract Amount:</b> \$183,000.00 <b>Completion Date:</b> May 13, 2006</p>
<p><b>Project Name:</b> Rosemary Park Paving &amp; Drainage Improvements</p> <p><b>Owner - Address - Project Manager - Phone:</b> City of Bonita Springs Public Works Department 9101 Bonita Beach Road Bonita Springs, Florida 239-949-6243</p> <p><b>Engineer - Address - Phone:</b> Q. Grady Minor 3800 Via Del Rey Bonita Springs 34134 David Schmitt 239-949-6243</p> <p><b>Contract Date:</b> April 5, 2006 <b>Final Contract Amount:</b> \$831,805.33 <b>Completion Date:</b> November 1, 2006</p>	<p><b>Project Name:</b> Forest Lakes MSTU Phase 2 Drainage Improvements</p> <p><b>Owner - Address - Project Manager - Phone:</b> Collier County - ATM Stormwater Department 2885 Horseshoe Drive South Naples, Florida 34104 Darryl Richard</p> <p><b>Engineer - Address:</b> Willson Miller 3200 Bailey Lane, Suite 200 Naples, Florida 34105 Craig Pejer</p> <p><b>Contract Date:</b> May 2, 2006 <b>Final Contract Amount:</b> \$193,287.00 <b>Completion Date:</b> July 19, 2006</p>
<p><b>Project Name:</b> Dortch Ave. Drainage &amp; Paving Impvs. Hampton Street Sidewalk Improvements</p> <p><b>Owner - Address - Project Manager - Phone:</b> City of Bonita Springs Public Works Department 9101 Bonita Beach Road Bonita Springs, Florida 239-949-6243</p> <p><b>Engineer - Address - Phone:</b> Q. Grady Minor 3800 Via Del Rey Bonita Springs 34134 David Schmitt 239-949-6243</p> <p><b>Contract Date:</b> March 15, 2006 <b>Final Contract Amount:</b> \$316,400.50 <b>Completion Date:</b> August 1, 2006</p>	<p><b>Project Name:</b> Lehigh Acres Interconnect with The City of Fort Myers</p> <p><b>Owner - Address - Project Manager - Phone:</b> Florida Governmental Utility Authority 280 Wekiva Springs Road, Suite 203 Longwood, Florida 32779</p> <p><b>Engineer - Address - Phone:</b> Malcom Pirnie, Inc. 2301 Maitland Center Parkway, Suite 425 Maitland, Florida 32751 Victor Hurlburt 407-659-5550</p> <p><b>Contract Date:</b> June 15, 2006 <b>Final Contract Amount:</b> \$2,884,382.00 <b>Completion Date:</b> April 2007</p>

**EXPERIENCE STATEMENT - SOUTHWEST DIVISION**

<p><b>Project Name:</b> Connection to Water Main - Marco Shores</p> <p><b>Owner - Address - Project Manager:</b>                  City of Marco Island                  Public Works                  50 Bald Eagle Drive                  Marco Island, Florida 34145                  James Miller</p> <p><b>Engineer - Address - Phone:</b></p> <p><b>Contract Date:</b> April 26, 2007  <b>Final Contract Amount:</b> \$188,000.00  <b>Completion Date:</b> August 31, 2007</p>	<p><b>Project Name:</b> Collier County NCRWTP AND SCRWTP Sand Separators</p> <p><b>Owner - Address - Project Manager - Phone:</b>                  Collier County Public Utilities                  3301 East Tamiami Trail                  Naples, Florida 34112                  Diana Dueri</p> <p><b>Engineer - Address - Phone:</b>                  Hazen and Sawyer</p> <p><b>Contract Date:</b> December 20, 2007  <b>Final Contract Amount:</b> \$1,453,249.71  <b>Completion Date:</b> July 17, 2009</p> <p><b>Project Description:</b>                  Procurement and installation of two automatic self-cleaning sand separators (custom built in Germany) including stainless steel piping, valves, instruments and control panels. Installation of system, which included two, three-chamber pump stations, submersible pumps, venturi flowmeters, etc.</p>
<p><b>Project Name:</b> SCRWTP Raw Water Transmission Main &amp; Appurtenances for Raw Water Wells 39S, 40S, 41S &amp; 42S</p> <p><b>Owner - Address - Project Manager - Phone:</b>                  Collier County                  Public Utilities Engineering Department                  3301 Tamiami Trail, Building H                  Naples, Florida 34112                  Peter Schall</p> <p><b>Engineer - Address - Phone:</b>                  Hazen &amp; Sawyer                  2101 Coporate Boulevard, Suite 301                  Boca Raton, Florida 33431                  Albert Muniz                  561-997-8070</p> <p><b>Contract Date:</b> September 26, 2006  <b>Final Contract Amount:</b> \$1,884,000.00  <b>Completion Date:</b> April 11, 2007  <b>Length of Contract:</b> 210 days</p> <p><b>Project Description:</b>                  Installed 3500 LF of 16-inch HDPE raw water transmission main and 3500 LF of Fiber Option and Electrical ductbanks, and instrumentation and Control Facilities at the four new water well facilities. This provided the plant the ability to produce sufficient capacity to meet water demands. Included installation of pigging stations and electrical enclosures.</p>	<p><b>Project Name:</b> Decommissioning of Pelican Bay Wastewater Treatment Plant</p> <p><b>Owner - Address - Project Manager - Phone:</b>                  Collier County                  Public Utilities Engineering Department                  3301 Tamiami Trail East, Building H                  Naples, Florida 34112                  Sandy Sridhar</p> <p><b>Engineer - Address - Phone:</b>                  Hazen and Sawyer                  2101 Corporate Boulevard, Suite 303                  Boca Raton, Florida 33431                  Kurt Pfeffer                  561-997-8070</p> <p><b>Contract Date:</b> February 8, 2006  <b>Final Contract Amount:</b> \$72,500.00  <b>Completion Date:</b> July 30, 2006</p>
<p><b>Project Name:</b> Pelican Bay Fire and Irrigation Water System Improvement at the Ritz Carlton</p> <p><b>Owner - Address - Project Manager:</b>                  Collier County                  Public Utilities Engineering Department                  3301 Tamiami Trail East, Building H                  Naples, Florida 34112                  Claude Nesbitt</p> <p><b>Engineer - Address - Phone:</b>                  Wilson Miller, Inc.                  3200 Bailey Lane, Suite 200                  Naples, Florida 34105                  Craig Pager                  800-649-4336</p> <p><b>Contract Date:</b> March 30, 2006  <b>Final Contract Amount:</b> \$162,723.43  <b>Completion Date:</b> February 28, 2007</p>	<p><b>Project Name:</b> Reclaimed Water Aquifer Storage and Recovery</p> <p><b>Owner - Address - Project Manager:</b>                  Collier County                  Public Utilities Engineering Department                  3301 Tamiami Trail East, Building H                  Naples, Florida 34112                  Alicia Abbott</p> <p><b>Engineer - Address:</b>                  Water Resource Solution                  1388 Colonial Boulevard                  Fort Myers, Florida 33907                  Lloyd Horvath</p> <p><b>Contract Date:</b> April 5, 2006  <b>Final Contract Amount:</b> \$4,658,515.28  <b>Completion Date:</b> June 6, 2007</p> <p><b>Project Description:</b>                  Installed a deep injection well for the storage of reclaimed water coming from Collier County water treatment plants. The Owner will have full capability to recover this reclaimed water for market and/or use for their own irrigation needs.</p>

EXPERIENCE STATEMENT - SOUTHWEST DIVISION

<p><b>Project Name:</b> Gateway Triangle Stormwater Improvements</p> <p><b>Owner - Address - Project Manager - Phone:</b>                  Collier County                  Stormwater Department                  2885 Horseshoe Drive                  Naples, Florida 34104                  Shane Cox 239-252-8192</p> <p><b>Engineer - Address:</b>                  HDR, Inc.                  200 West Forsyth Street                  Jacksonville, Florida 32202                  Laura Phillips</p> <p><b>Contract Date:</b> November 5, 2007  <b>Final Contract Amount:</b> \$1,021,336.78  <b>Completion Date:</b> July 28, 2008</p> <p><b>Project Description:</b>                  Stormwater improvements to existing area - excavation of approximately 34,000 Cy of dirt and grading to form three continuous ponds. Installation of box culverts, sheet piling, concrete ditch pavement and storm drainage structures.</p>	<p><b>Project Name:</b> Marco Island North Barfield &amp; North Marco Sanitary Sewer District</p> <p><b>Owner - Address - Project Manager - Phone:</b>                  City of Marco Island                  50 Bald Eagle Drive                  Marco Island, FL 34145                  Mr. James Miller                  239-389-5011</p> <p><b>Engineer - Address - Phone:</b>                  Bolye Engineering                  4415 Metro Parkway, Suite 104                  Fort Myers, FL 33916                  Fred Mittl                  239-278-7996</p> <p><b>Contract Date:</b> March 1, 2007</p> <p><b>Final Contract Amount:</b> North Marco \$4,644,806.99                  North Barfield \$7,270,729.37</p> <p><b>Completion Date:</b> North Marco May 11, 2008                  North Barfield March 24, 2008</p>
<p><b>Project Name:</b> NCWRF MLE Bleach Project Phase 2, Mechanical</p> <p><b>Owner - Address - Project Manager:</b>                  Collier County                  Public Utilities Engineering Department                  3301 Tamiami Trail, East, Building H                  Naples, Florida 34112                  Dianna Dueri</p> <p><b>Engineer - Address - Phone:</b>                  Hole Montes                  950 Encore Way                  Naples, Florida 34110                  Jerry Taricska 239-254-2000</p> <p><b>Contract Date:</b> September 17, 2007  <b>Final Contract Amount:</b> \$336,412.49  <b>Completion Date:</b> June 17, 2008</p> <p><b>Project Description:</b>                  Bleach piping modifications to chlorine contact chambers and modification of pump skids to have redundancy in bleach feed system.</p>	<p><b>Project Name:</b> Rehabilitation of Master Pump Station 316</p> <p><b>Owner - Address - Project Manager:</b>                  Collier County                  Public Utilities Engineering Department                  3301 Tamiami Trail East, Building H                  Naples, Florida 34112                  Sandy Sridhar</p> <p><b>Engineer - Address - Phone:</b>                  Q. Grady Minor &amp; Associates                  3800 Via Del Rey                  Bonita Springs, Florida 34134                  David Schmitt                  239-947-1144</p> <p><b>Contract Date:</b> November 16, 2007  <b>Final Contract Amount:</b> \$765,823.34  <b>Completion Date:</b> June 3, 2008</p> <p><b>Project Description:</b>                  Full rehab 800 GPM Master Pump Station</p>
<p><b>Project Name:</b> Rehabilitation of Master Pump Station 318</p> <p><b>Owner - Address - Project Manager - Phone:</b>                  Collier County                  Public Utilities Engineering Department                  3301 Tamiami Trail East, Building H                  Naples, Florida 34112                  Sandy Sridhar</p> <p><b>Engineer - Address - Phone:</b>                  Q. Grady Minor &amp; Associates                  3800 Via Del Rey                  Bonita Springs, Florida 34134                  David Schmitt                  239-947-1144</p> <p><b>Contract Date:</b> October 9, 2007  <b>Final Contract Amount:</b> \$789,070.59  <b>Completion Date:</b> June 10, 2008</p> <p><b>Project Description:</b>                  Fully rehab 3000 GPM Master Pump Station</p>	<p><b>Project Name:</b> NCRWTP Chemical Laboratory Ventilation Improvements</p> <p><b>Owner - Address - Project Manager - Phone:</b>                  Collier County                  Public Utilities Engineering Department                  3301 Tamiami Trail East, Building H                  Naples, Florida 34112                  Tom Chmelik                  239-732-2575</p> <p><b>Engineer - Address - Phone:</b>                  TLC Engineering                  1400 Colonial Boulevard, Suite 203                  Fort Myers, Florida 33907                  Nicholas L. Mancuso                  239-275-4240</p> <p><b>Contract Date:</b> March 13, 2007  <b>Final Contract Amount:</b> \$749,367.67  <b>Completion Date:</b> November 30, 2008</p> <p><b>Project Description:</b>                  Replace complete HVAC system including air handler, ductwork, exhaust fans, condenser and rehab fume hoods</p>



EXPERIENCE STATEMENT - SOUTHWEST DIVISION

<p><b>Project Name:</b> CAT Operations &amp; Administration Center Pump Station and Force Main Connection</p> <p><b>Owner - Address - Project Manager:</b> Collier County Alternative Transportation Division 2885 South Horseshoe Drive Naples, Florida 34104 Sue Faulkner</p> <p><b>Engineer:</b> Q. Grady Minor 3800 Via Del Rey Bonita Springs, Florida 34134</p> <p><b>Contract Date:</b> February 14, 2008 <b>Final Contract Amount:</b> \$133,673.04 <b>Completion Date:</b> May 1, 2008 <b>Project Description:</b> Installation of 14-inch force main, pump station and valve vault to existing CAT Operations Building.</p>	<p><b>Project Name:</b> San Marco Master Lift Station</p> <p><b>Owner - Address - Project Manager - Phone:</b> City of Marco Island Public Works 50 Bald Eagle Drive Marco Island, Florida 34145 Timothy E. Pinter, P.E.</p> <p><b>Engineer - Address - Phone:</b></p> <p><b>Contract Date:</b> January 2, 2008 <b>Final Contract Amount:</b> \$833,615.61 <b>Completion Date:</b></p> <p><b>Project Description:</b> Construct new 800 GPM Master Lift Station</p>
<p><b>Project Name:</b> Irrigation Quality Water Project</p> <p><b>Owner - Address - Project Manager:</b> Collier County Facilities Management 3301 Tamiami Trail East, Building W Naples, Florida 34112 Damon Gonzales</p> <p><b>Engineer - Address - Phone:</b> Anchor Engineering</p> <p><b>Contract Date:</b> March 14, 2007 <b>Final Contract Amount:</b> \$1,213,474.52 <b>Completion Date:</b> January 15, 2008</p>	<p><b>Project Name:</b> Golden Gate WWTP and Injection Pump Station</p> <p><b>Owner - Address - Project Manager - Phone:</b> Florida Governmental Utility Authority 280 Wekiva Springs Road, Suite 203 Longwood, Florida 32779</p> <p><b>Engineer - Address - Phone:</b> Arcadis 2092 Old Arbor Ct. Sarasota, FL 34232 813-335-1799</p> <p><b>Contract Date:</b> August 17, 2008 <b>Final Contract Amount:</b> \$2,621,907.78 <b>Completion Date:</b> May 10, 2010 <b>Project Description:</b> Expansion of Golden Gate WWTP which included the construction of a new digester, chlorine contact tank and injection well pump station, modification of clarifiers #1 and #2, installation of surge and annular pressure tanks and appurtenances.</p>
<p><b>Project Name:</b> Treeline Master Pump Station</p> <p><b>Owner - Address - Project Manager - Phone:</b> City of Fort Myers 2200 Second Street Fort Myers, Florida 33902 Ellana Hayes, E.I. (239) 332-6318</p> <p><b>Engineer - Address - Phone:</b> Johnson Engineering, Inc. 2122 Johnson Street Fort Myers, Florida 33920 David Trouteaud (239) 334-0046</p> <p><b>Contract Date:</b> July 1, 2008 <b>Final Contract Amount:</b> \$1,043,805.00 <b>Completion Date:</b> February, 2009 <b>Project Description:</b> Installation of a master pump station located along Treeline Avenue. The project entailed a jack and bore under Treeline Avenue to connect to the existing force main and construction of a 20 foot deep master pump station. A 400 KW generator and odor control unit were also installed.</p>	<p><b>Project Name:</b> PS S-127 and S-133 Pump Refurbishment and Bearing Replace.</p> <p><b>Owner - Address - Project Manager - Phone:</b> South Florida Water Management District 2101 Centrepark West Drive, Suite 110 West Palm Beach, Florida 33409 Mike Curley</p> <p><b>Engineer - Address - Phone:</b> South Florida Water Management District 3301 Gun Club Road West Palm Beach, Florida 33406 Teri Swartz</p> <p><b>Contract Date:</b> April 10, 2008 <b>Final Contract Amount:</b> \$3,947,723.00 <b>Completion Date:</b> July 2010</p>

EXPERIENCE STATEMENT - SOUTHWEST DIVISION

<p><b>Project Name:</b> City County Flow Swap</p> <p><b>Owner - Address - Project Manager - Phone:</b>                  Collier County Public Utilities Engineering                  3301 East Tamiami Trail, Building H                  Naples, Florida 34112                  Sandy Sridhar</p> <p><b>Engineer - Address - Phone:</b>                  Agnoli, Barber and Brundage                  7400 Trail Blvd.                  Naples, Florida 34102                  Dominic Amico</p> <p><b>Contract Date:</b> July 27, 2009  <b>Final Contract Amount:</b> \$132,794.26  <b>Completion Date:</b> September 9, 2009  <b>Project Description:</b>                  Installation of force main, MOV's and valve vaults to two locations which would allow bypass from Collier County to the City of Naples.</p>	<p><b>Project Name:</b> Collier County Justice Center</p> <p><b>Owner - Address - Project Manager - Phone:</b>                  Collier County Facilities Management Department                  3301 East Tamiami Trail                  Naples, Florida 34112                  John Clements</p> <p><b>Engineer - Address - Phone:</b>                  Q. Grady Minor and Associates, P.A.                  3800 Via Del Rey                  Bonita Springs, Florida 34134                  David Schmitt                  239-947-1144</p> <p><b>Contract Date:</b> March 11, 2009  <b>Final Contract Amount:</b> \$141,568.41  <b>Completion Date:</b> August, 2009  <b>Project Description:</b>                  Construction of grinder pump station (vault), installation of muffin monster (grinder/auger assembly), new sanitary sewer and manholes. Replacement of the existing sanitary sewer with a new 12-inch main and a high water alarm system.</p>
<p><b>Project Name:</b> Pump Station S-6 Gearbox Replacement</p> <p><b>Owner - Address - Project Manager - Phone:</b>                  South Florida Water Management District                  2101 Centrepark West Drive, Suite 110                  West Palm Beach, Florida 33409                  Gerard Flynn</p> <p><b>Engineer - Address - Phone:</b>                  South Florida Water Management District                  3301 Gun Club Road                  West Palm Beach, Florida 33406                  Michael Millares</p> <p><b>Contract Date:</b> December 3, 2009  <b>Final Contract Amount:</b> \$2,191,945.00  <b>Completion Date:</b> May 2010</p>	<p><b>Project Name:</b> Cove Stormwater Pump Station Imp.</p> <p><b>Owner - Address - Project Manager - Phone:</b>                  City of Naples                  Department of Streets and Stormwater                  295 Riverside Circle                  Naples, Florida 34102                  (239) 213-5000</p> <p><b>Engineer - Address - Phone:</b>                  AECOM                  4415 Metro Parkway                  Suite 404                  Fort Myers, Florida 33916                  (239) 278-7996</p> <p><b>Contract Date:</b> 2/4/09 Award, 3/16/09 NTP  <b>Final Contract Amount:</b> \$2,798,870.00  <b>Completion Date:</b> 2/8/10 (Contract)</p>
<p><b>Project Name:</b> Master Pump Station 305 Rehabilitation</p> <p><b>Owner - Address - Project Manager</b>                  Collier County                  Public Utilities Engineering Department                  3301 Tamiami Trail East, Building H                  Naples, Florida 34112                  Sandy Sridhar</p> <p><b>Engineer - Address:</b>                  Q. Grady Minor and Associates, P.A.                  3800 Via Del Rey                  Bonita Springs, Florida 34134                  David Schmitt</p> <p><b>Contract Date:</b> August 11, 2008  <b>Final Contract Amount:</b> \$444,000.00  <b>Completion Date:</b> January 16, 2009  <b>Project Description:</b>                  Fully rehab 2300 GPM Master Pump Station</p>	<p><b>Project Name:</b> Water Reuse Piping Modifications / Reuse System Upgrade</p> <p><b>Owner - Address - Project Manager - Phone:</b>                  City of Marco Island                  Public Utilities                  50 Bald Eagle Drive                  Marco Island, Florida 34145                  Bruce Weinstein                  239-389-5000</p> <p><b>Engineer:</b>                  Metcalf and Eddy</p> <p><b>Contract Date:</b> February 10, 2008  <b>Final Contract Amount:</b> \$649,171.67  <b>Completion Date:</b> November 2008  <b>Project Description:</b>                  Rehab 500,000 Gallon Tank and convert potable water facility to reuse storage facility</p>

**FLORIDA BID BOND**

BOND NO. \_\_\_\_\_

AMOUNT: \$ 5%

KNOW ALL MEN BY THESE PRESENTS, that Douglas N. Higgins, Inc.

hereinafter called the PRINCIPAL, and Hartford Fire Insurance Company

a corporation duly organized under the laws of the State of CT

having its principal place of business at One Hartford Plaza, T-4, Hartford, CT 06155

in the State of CT

and authorized to do business in the State of Florida, as SURETY, are held and firmly bound unto

City of Key West, FL

hereinafter called the OBLIGEE, in the sum of five percent of attached bid

DOLLARS (\$ 5%) for the payment for which we bind ourselves, our heirs, executors, administrators, successors, and assigns, jointly and severally, firmly by these present.

THE CONDITION OF THIS BOND IS SUCH THAT:

WHEREAS, the PRINCIPAL is herewith submitting his or its Bid Proposal for Cemetery Mausoleums, said Bid Proposal, by reference thereto, being hereby made a part hereof.

WHEREAS, the PRINCIPAL contemplates submitting or has submitted a bid to the OBLIGEE for the furnishing of all labor, materials (except those to be specifically furnished by the CITY), equipment, machinery, tools, apparatus, means of transportation for, and the performance of the work covered in the Proposal and the detailed Specifications, entitled:

KEY WEST CITY CEMETERY MAUSOLEUMS CE1003

WHEREAS, it was a condition precedent to the submission of said bid that a cashier's check, certified check, or bid bond in the amount of 5 percent of the base bid be submitted with said bid as a guarantee that the Bidder would, if awarded the Contract, enter into a written Contract with the CITY for the performance of said Contract, within 10 working days after written notice having been given of the award of the Contract.

NOW, THEREFORE, the conditions of this obligation are such that if the PRINCIPAL within 10 consecutive calendar days after written notice of such acceptance, enters into a written Contract with the OBLIGEE and furnishes the Performance and Payment Bonds, each in an amount equal to 100 percent of the base bid, satisfactory to the CITY, then this obligation shall be void; otherwise the sum herein stated shall be due and payable to the OBLIGEE and the Surety herein agrees to pay said sum immediately upon demand of the OBLIGEE in good and lawful money of the United States of America, as liquidated damages for failure thereof of said PRINCIPAL.

Signed and sealed this 9th day of January, 2013.

PRINCIPAL

Douglas N. Higgins, Inc.

By Kelly A. Wilkie  
Kelly A. Wilkie, Vice-President

Hartford Fire Insurance Company

SURETY

By Heather M. Johnson  
Attorney-In-Fact Heather M. Johnson

Dale A. Belis  
Dale A. Belis, FL Resident Agent

# POWER OF ATTORNEY

Direct Inquiries/Claims to:

THE HARTFORD

BOND, T-4

One Hartford Plaza

Hartford, Connecticut 06155

call: 888-266-3488 or fax: 860-757-5835

KNOW ALL PERSONS BY THESE PRESENTS THAT:

Agency Code: 35-350851

- Hartford Fire Insurance Company, a corporation duly organized under the laws of the State of Connecticut
- Hartford Casualty Insurance Company, a corporation duly organized under the laws of the State of Indiana
- Hartford Accident and Indemnity Company, a corporation duly organized under the laws of the State of Connecticut
- Hartford Underwriters Insurance Company, a corporation duly organized under the laws of the State of Connecticut
- Twin City Fire Insurance Company, a corporation duly organized under the laws of the State of Indiana
- Hartford Insurance Company of Illinois, a corporation duly organized under the laws of the State of Illinois
- Hartford Insurance Company of the Midwest, a corporation duly organized under the laws of the State of Indiana
- Hartford Insurance Company of the Southeast, a corporation duly organized under the laws of the State of Florida

having their home office in Hartford, Connecticut, (hereinafter collectively referred to as the "Companies") do hereby make, constitute and appoint, up to the amount of unlimited:

*Heather M. Johnson, Joel E. Speckman, Terri Mahakian, David Harlock*  
of  
*Ann Arbor, MI*

their true and lawful Attorney(s)-in-Fact, each in their separate capacity if more than one is named above, to sign its name as surety(ies) only as delineated above by , and to execute, seal and acknowledge any and all bonds, undertakings, contracts and other written instruments in the nature thereof, on behalf of the Companies in their business of guaranteeing the fidelity of persons, guaranteeing the performance of contracts and executing or guaranteeing bonds and undertakings required or permitted in any actions or proceedings allowed by law.

In Witness Whereof, and as authorized by a Resolution of the Board of Directors of the Companies on January 22, 2004 the Companies have caused these presents to be signed by its Assistant Vice President and its corporate seals to be hereto affixed, duly attested by its Assistant Secretary. Further, pursuant to Resolution of the Board of Directors of the Companies, the Companies hereby unambiguously affirm that they are and will be bound by any mechanically applied signatures applied to this Power of Attorney.



*Wesley W. Cowling*

Wesley W. Cowling, Assistant Secretary

*M. Ross Fisher*

M. Ross Fisher, Assistant Vice President

STATE OF CONNECTICUT }  
COUNTY OF HARTFORD } ss. Hartford

On this 3<sup>rd</sup> day of November, 2008, before me personally came M. Ross Fisher, to me known, who being by me duly sworn, did depose and say: that he resides in the County of Hartford, State of Connecticut; that he is the Assistant Vice President of the Companies, the corporations described in and which executed the above instrument; that he knows the seals of the said corporations; that the seals affixed to the said instrument are such corporate seals; that they were so affixed by authority of the Boards of Directors of said corporations and that he signed his name thereto by like authority.



CERTIFICATE

*Scott E. Paseka*

Scott E. Paseka  
Notary Public

My Commission Expires October 31, 2012

I, the undersigned, Assistant Vice President of the Companies, DO HEREBY CERTIFY that the above and foregoing is a true and correct copy of the Power of Attorney executed by said Companies, which is still in full force effective as of January 9, 2013.

Signed and sealed at the City of Hartford.



*Gary W. Stumper*

Gary W. Stumper, Assistant Vice President

STATE OF ~~FLORIDA~~ MICHIGAN )  
COUNTY OF ~~MONROE~~ WASHTENAW : SS )

I, the undersigned hereby duly sworn, depose and say that no portion of the sum herein bid will be paid to any employees of the City of Key West as a commission, kickback, reward or gift, directly or indirectly by me or any member of my firm or by an officer of the corporation.

By: Kellya Wilkie

Sworn and subscribed before me this 9th day of January, 2013.

NOTARY PUBLIC, State of ~~Florida~~ Michigan at Large

My Commission Expires: R. Suzanne Hawker

**R. SUZANNE HAWKER**  
Notary Public, Washtenaw County, MI  
My Commission Expires Mar 7, 2017

\*\*\*\*\*

ANTI-KICKBACK AFFIDAVIT

MICHIGAN  
STATE OF FLORIDA )  
WASHTENAW : SS  
COUNTY OF MONROE )

I, the undersigned hereby duly sworn, depose and say that no portion of the sum herein bid will be paid to any employees of the City of Key West as a commission, kickback, reward or gift, directly or indirectly by me or any member of my firm or by an officer of the corporation.

By: Kelly A. Wilkie

Sworn and subscribed before me this 9th day of January, 2013.

Michigan  
NOTARY PUBLIC, State of Florida at Large

My Commission Expires: R. Suzanne Hawker

**R. SUZANNE HAWKER**  
Notary Public, Washtenaw County, MI  
My Commission Expires Mar 7, 2017

\* \* \* \* \*

SWORN STATEMENT UNDER SECTION 287.133(3)(A)  
FLORIDA STATUTES, ON PUBLIC ENTITY CRIMES

**THIS FORM MUST BE SIGNED IN THE PRESENCE OF A NOTARY PUBLIC OR OTHER OFFICER AUTHORIZED TO ADMINISTER OATHS.**

1. This sworn statement is submitted with Bid or Proposal for ITB 13-002  
Construct Key West Cemetery Mausoleum

2. This sworn statement is submitted by Douglas N. Higgins, Inc.  
(name of entity submitting sworn statement)

whose business address is 3390 Travis Pointe Rd. Suite A  
Ann Arbor, MI 48108

and (if applicable) its Federal Employer Identification Number (FEIN) is \_\_\_\_\_  
38-1807765

(If the entity has no FEIN, include the Social Security Number of the individual signing this sworn statement \_\_\_\_\_)

3. My name is Kelly A. Wikie  
(please print name of individual signing)

and my relationship to the entity named above is Vice-President

4. I understand that a "public entity crime" as defined in Paragraph 287.133(1)(g), Florida Statutes, means a violation of any state or federal law by a person with respect to and directly related to the transaction of business with any public entity or with an agency or political subdivision of any other state or with the United States, including but not limited to, any bid or contract for goods or services to be provided to any public or an agency or political subdivision of any other state or of the United States and involving antitrust, fraud, theft, bribery, collusion, racketeering, conspiracy, material misrepresentation.

5. I understand that "convicted" or "conviction" as defined in Paragraph 287.133(1)(b), Florida Statutes, means a finding of guilt or a conviction of a public entity crime, with or without an adjudication guilt, in any federal or state trial court of record relating to charges brought by indictment information after July 1, 1989, as a result of a jury verdict, nonjury trial, or entry of a plea of guilty or nolo contendere.

6. I understand that an "affiliate" as defined in Paragraph 287.133(1)(a), Florida Statutes, means



- a. A predecessor or successor of a person convicted of a public entity crime; or
  - b. An entity under the control of any natural person who is active in the management of the entity and who has been convicted of a public entity crime. The term "affiliate" includes those officers, directors, executives, partners, shareholders, employees, members, and agents who are active in the management of an affiliate. The ownership by one person of shares constituting controlling interest in another person, or a pooling of equipment or income among persons when not for fair market value under an arm's length agreement, shall be a prima facie case that one person controls another person. A person who knowingly enters into a joint venture with a person who has been convicted of a public entity crime in Florida during the preceding 36 months shall be considered an affiliate.
7. I understand that a "person" as defined in Paragraph 287.133(1)(8), Florida Statutes, means any natural person or entity organized under the laws of any state or of the United States with the legal power to enter into a binding contract and which bids or applies to bid on contracts for the provision of goods or services let by a public entity, or which otherwise transacts or applies to transact business with public entity. The term "person" includes those officers, directors, executives, partners, shareholders, employees, members, and agents who are active in management of an entity.
8. Based on information and belief, the statement which I have marked below is true in relation to the entity submitting this sworn statement. (Please indicate which statement applies).

Neither the entity submitting this sworn statement, nor any officers, directors, executives, partners, shareholders, employees, members, or agents who are active in management of the entity, nor any affiliate of the entity have been charged with and convicted of a public entity crime subsequent to July 1, 1989, AND (Please indicate which additional statement applies.)

There has been a proceeding concerning the conviction before a hearing of the State of Florida, Division of Administrative Hearings. The final order entered by the hearing officer did not place the person or affiliate on the convicted vendor list. (Please attach a copy of the final order.)

The person or affiliate was placed on the convicted vendor list. There has been a subsequent proceeding before a hearing officer of the State of

Florida, Division of Administrative Hearings. The final order entered by the hearing officer determined that it was in the public interest to remove the person or affiliate from the convicted vendor list. (Please attach a copy of the final order.)

The person or affiliate has not been put on the convicted vendor list. (Please describe any action taken by or pending with the Department of General Services.)

Kelly A. Wilkie  
 (signature)  
January 9, 2013  
 PUBLIC ENTITY CRIMES

(date)

STATE OF Michigan

COUNTY OF Washtenaw

PERSONALLY APPEARED BEFORE ME, the undersigned authority,

Kelly A. Wilkie who, after first being sworn by me, affixed his/her  
(name of individual signing)

signature in the space provided above on this 9th day of January, 2013.

My commission expires:

**R. SUZANNE HAWKER**  
Notary Public, Washtenaw County, MI  
My Commission Expires Mar 7, 2017

R. Suzanne Hawker  
NOTARY PUBLIC

**INDEMNIFICATION**

To the fullest extent permitted by law, the CONTRACTOR expressly agrees to indemnify and hold harmless the City of Key West, their officers, directors, agents, and employees (herein called the "indemnitees") from liabilities, damages, losses and costs, including, but not limited to, reasonable attorney's fees and court costs, such legal expenses to include costs incurred in establishing the indemnification and other rights agreed to in this Paragraph, to persons or property, to the extent caused by the negligence, recklessness, or intentional wrongful misconduct of the CONTRACTOR, its Subcontractors or persons employed or utilized by them in the performance of the Contract. Claims by indemnitees for indemnification shall be limited to the amount of CONTRACTOR's insurance or \$1 million per occurrence, whichever is greater. The parties acknowledge that the amount of the indemnity required hereunder bears a reasonable commercial relationship to the Contract and it is part of the project specifications or the bid documents, if any.

The indemnification obligations under the Contract shall not be restricted in any way by any limitation on the amount or type of damages, compensation, or benefits payable by or for the CONTRACTOR under workers' compensation acts, disability benefits acts, or other employee benefits acts, and shall extend to and include any actions brought by or in the name of any employee of the CONTRACTOR or of any third party to whom CONTRACTOR may subcontract a part or all of the Work. This indemnification shall continue beyond the date of completion of the work.

CONTRACTOR: Douglas N. Higgins, Inc.  
3390 Travis Pointe Rd. Suite A  
Ann Arbor, MI 48108  
Address

SEAL:

Kelly A. Wilkie  
Signature

Kelly A. Wilkie  
Print Name

Vice-President  
Title

DATE: January 9, 2013

**CITY OF KEY WEST BUSINESS LICENSE TAX RECEIPT**

1. A City of Key West Business License Tax Receipt is required for this Project. Contractor must be general contractor or building contractor or engineering contractor.
  
2. A City of Key West Business License Tax Receipt also is required as for sub-contracting landscaping contractor, engineering services, and professional surveying.
  
3. A Business License Tax Application can be found on the City's web site.

**<http://www.keywestcity.com/egov/docs/1162843921181.htm>**

# Business License Tax Application

City of Key West  
City Hall Annex  
PO Box 1409  
Key West, FL 33041

Date Applied \_\_\_\_\_

License # \_\_\_\_\_  
Phone 305-809-3955  
Fax 305-809-3978

Business Type: \_\_\_\_\_

Business Name: \_\_\_\_\_

Business Location: \_\_\_\_\_

Business Owner: \_\_\_\_\_

State Licensed Qualifier (if applicable): \_\_\_\_\_

Mailing Address: \_\_\_\_\_

EIN / SS # \_\_\_\_\_ Phone # \_\_\_\_\_

\_\_\_\_\_  
Applicant name (printed)      Applicant signature      Date

State of Florida  
County of Monroe  
The foregoing instrument was acknowledged before me this \_\_\_\_ day of \_\_\_\_\_, 20\_\_\_\_, by \_\_\_\_\_.

\_\_\_\_\_  
Signature of Notary Public      (stamp or seal). Personally known \_\_\_\_  
Produced id \_\_\_\_\_

-----  
\_\_\_\_ Sales Tax number 3106 Flagler Ave 292-6735      City utility acct \_\_\_\_\_  
\_\_\_\_ Commercial garbage Waste Mgmt 296-8297      \_\_\_\_\_  
\_\_\_\_ Lease or deed  
\_\_\_\_ State License DBPR 850-487-1395 / Dept Ag 305-470-6900  
\_\_\_\_ Home occupation application  
\_\_\_\_ Fictitious Name registration      Previous use \_\_\_\_\_  
\_\_\_\_ Corporate or LLC registration  
\_\_\_\_ Liability / Worker's Comp      Zoning \_\_\_\_\_  
\_\_\_\_ Fire Inspector 292-8179  
\_\_\_\_ CO / final inspection on any permits      Category \_\_\_\_\_ Fee \$ \_\_\_\_\_  
\_\_\_\_ Monroe County or local licensing

Licensed in accordance with Chapter 66, Key West Code of Ordinances  
\_\_\_\_ Approved      Denied / Reason \_\_\_\_\_

\_\_\_\_\_  
Licensing Official      Date

# CITY OF KEY WEST, FLORIDA

## Business Tax Receipt

This Document is a business tax receipt

Holder must meet all City zoning and use provisions.  
P.O. Box 1409, Key West, Florida 33040 (305) 809-3955

Business Name DOUGLAS N. HIGGINS (CGC) CTLNbr:0018021  
Location Addr 3390 TRAVIS POINTE STE A RD  
Lic NBR/Class 13-00022114 CONTRACTOR - CERT GENERAL CONTRACTOR  
Issue Date: November 13, 2012 Expiration Date: September 30, 2013  
License Fee \$309.75  
Add. Charges \$0.00  
Penalty \$0.00  
Total \$0.00

Comments:

This document must be prominently displayed.

DOUGLAS N. HIGGINS, INC

DOUGLAS N. HIGGINS (CGC)  
3390 TRAVIS POINTE STE A RD

ANN ARBOR MI 48108

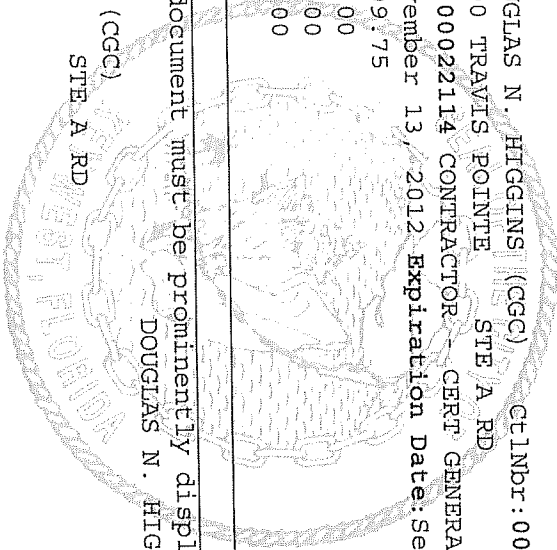



STATE OF FLORIDA

DEPARTMENT OF BUSINESS AND PROFESSIONAL REGULATION

CONSTRUCTION INDUSTRY LICENSING BOARD
1940 NORTH MONROE STREET
TALLAHASSEE FL 32399-0783

(850) 487-1395

HIGGINS, DANIEL NORMAN
DOUGLAS N HIGGINS INC
3390 TRAVIS POINTE ROAD
SUITE A
ANN ARBOR MI 48108

Congratulations! With this license you become one of the nearly one million Floridians licensed by the Department of Business and Professional Regulation.

Every day we work to improve the way we do business in order to serve you better. For information about our services, please log onto www.myfloridalicense.com.

Our mission at the Department is: License Efficiently, Regulate Fairly. We constantly strive to serve you better so that you can serve your customers.



STATE OF FLORIDA AC# 6307015
DEPARTMENT OF BUSINESS AND PROFESSIONAL REGULATION

CGC060189 08/27/12 118195796

CERTIFIED GENERAL CONTRACTOR
HIGGINS, DANIEL NORMAN
DOUGLAS N HIGGINS INC

IS CERTIFIED under the provisions of Ch.489 FS
Expiration date: AUG 31, 2014 L12082701996

DETACH HERE

THIS DOCUMENT HAS A SOLIDIFIED BACKGROUND AND CONTAINS NO INFORMATION THAT IS UNLAWFULLY OBTAINED

AC# 6307015

STATE OF FLORIDA

DEPARTMENT OF BUSINESS AND PROFESSIONAL REGULATION
CONSTRUCTION INDUSTRY LICENSING BOARD

SEQ# L12082701996

Table with 3 columns: DATE, BATCH NUMBER, LICENSE NBR. Row 1: 08/27/2012, 118195796, CGC060189

The GENERAL CONTRACTOR
Named below IS CERTIFIED
Under the provisions of Chapter 489 FS.
Expiration date: AUG 31, 2014

HIGGINS, DANIEL NORMAN
DOUGLAS N HIGGINS INC
3390 TRAVIS POINTE ROAD
SUITE A
ANN ARBOR MI 48108

RICK SCOTT
GOVERNOR

KEN LAWSON
SECRETARY

CERTIFICATE OF SECRETARY

The undersigned, being the duly elected secretary of Douglas N. Higgins, Inc., a Michigan corporation, hereby certifies that the following resolution was duly adopted by the Board of Directors of said corporation at a meeting held on May 15, 2012 and that said resolution is in full force and effect:

"RESOLVED, That the following listed persons are hereby authorized to execute, on behalf of Douglas N. Higgins, Inc., any and all contracts and documents."

Douglas N. Higgins

Daniel N. Higgins

William D. Higgins

James H. Sweet

Kelly A. Wilkie

*[Signature]*

*[Signature]*

*[Signature]*

*[Signature]*

*[Signature]*

*[Signature]*

R. Suzanne Hawker  
Secretary

Dated: May 15, 2012

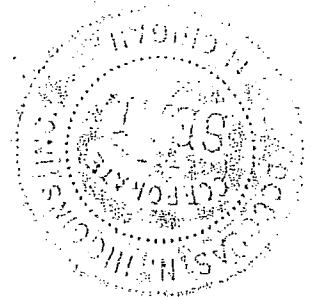



# *State of Florida*

## *Department of State*

I certify from the records of this office that DOUGLAS N. HIGGINS INC. is a corporation organized under the laws of Michigan, authorized to transact business in the State of Florida, qualified on August 1, 1973.

The document number of this corporation is 830666.

I further certify that said corporation has paid all fees due this office through December 31, 2012, that its most recent annual report was filed on January 17, 2012, and its status is active.

I further certify that said corporation has not filed a Certificate of Withdrawal.

*Given under my hand and the Great Seal of  
Florida, at Tallahassee, the Capital, this the  
Eighteenth day of January, 2012*

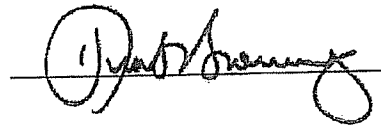

*Secretary of State*



Authentication ID: 000218635270-011812-830666

To authenticate this certificate, visit the following site, enter this ID, and then follow the instructions displayed.

<https://efile.sunbiz.org/certauthver.html>

# Licensing Division

P.O. Box 1409, Key West, FL 33041  
305.809.3955 305.809.3978 (FAX)

## REQUIREMENTS FOR STATE CERTIFIED CONTRACTOR REGISTERING TO WORK IN KEY WEST LESS THAN 30 DAYS PER FISCAL YEAR

1. NEED STATE OF FLORIDA CERTIFIED CONTRACTOR LICENSE.
2. BUSINESS LICENSE TAX RECEIPT FROM BASE LOCATION.
3. LIABILITY INSURANCE AND WORKER'S COMPENSATION  
(WITH THE CITY OF KEY WEST CERTIFICATE HOLDERS) SET  
AT STATE STUTUTE REQUIREMENTS.
4. FEDERAL I.D. NUMBER /SOCIAL SERCURITY (IF NOT  
INCORPORATED).
5. LETTER OF INTENT STATING THE FOLLOWING:

BUSINESS NAME

JOB SITE

DAYS INTENDING ON WORKING IN THE CITY

PLEASE FAX DOCUMENTS TO THE TELEPHONE NUMBER LISTED BELOW, OR MAIL TO CAROLYN  
WALKER / KIM PITA, CITY OF KEY WEST LICENSE DIVISION, P.O. BOX 1409, KEY WEST, FLORIDA 33041.

**EQUAL BENEFITS FOR DOMESTIC PARTNERS AFFIDAVIT**

MICHIGAN

STATE OF FLORIDA )

: SS

COUNTY OF WASHTENAW )

I, the undersigned hereby duly sworn, depose and say that the firm of Douglas N. Higgins, Inc. provides benefits to domestic partners of its employees on the same basis as it provides benefits to employees' spouses per City of Key West Ordinance Sec. 2-799.

By: Kellya. Ulke

Sworn and subscribed before me this

9th day of January, 2013.

\_\_\_\_\_  
NOTARY PUBLIC, State of Michigan at Large

R. Suzanne Hawker

My Commission Expires: \_\_\_\_\_  
**R. SUZANNE HAWKER**

Notary Public, Washtenaw County, MI  
My Commission Expires Mar 7, 2017

## BIDDER'S CHECKLIST

(Note: The purpose of this checklist is to serve as a reminder of major items to be addressed in submitting a bid and is not intended to be all inclusive. It does not alleviate the Bidder from the responsibility of becoming familiar with all aspects of the Contract Documents and proper completion and submission of his bid.)

1. All Contract Documents thoroughly read and understood.
2. All blank spaces in Proposal filled in, using black ink.
3. Total and unit prices added correctly.
4. Addenda acknowledged.
5. Subcontractors are named as indicated in the Proposal.
6. Experience record included.
7. Proposal signed by authorized officer.
8. Bid Bond completed and executed, including power-of-attorney dated the same date as Bid Bond.
9. Bidder familiar with federal, state, and local laws, ordinances, rules and regulations affecting performance of the work.
10. Bidder, if successful, able to obtain and/or demonstrate possession of required licenses and certificates within (10) ten calendar days after receiving a Notice of Award.
11. BID submitted intact with the volume entitled "Bidding Requirements" and "Contract Forms", 1 original, 1 copy and 2 flash drives as stated in the invitation to bid.
12. Bid Documents submitted in sealed envelope and addressed and labeled in conformance with the instructions in the Invitation to Bid.

---

**PART 2**

**CONTRACT FORMS**

---

CONTRACT

This Contract, made and entered into this \_\_\_\_\_ day of \_\_\_\_\_ 2013,  
by and between the City of Key West, hereinafter called the "Owner", and \_\_\_\_\_

\_\_\_\_\_

hereinafter called the "Contractor";

WITNESSETH:

The Contractor, in consideration of the sum to be paid him by the Owner and of the covenants and agreements herein contained, hereby agrees at his own proper cost and expense to do all the work and furnish all the materials, tools, labor, and all appliances, machinery, and appurtenances for ITB 13-002 CONSTRUCT KEY WEST CITY CEMETERY MAUSOLEUMS CE 1003, Key West, Florida to the extent of the Proposal made by the Contractor, dated the \_\_\_\_\_ day of 2013, all in full compliance with the Contract Documents referred to herein.

The CONTRACT DOCUMENTS, including the signed copy of the PROPOSAL, CONTRACT FORMS, PERFORMANCE & PAYMENT BONDS AND SCOPE OF WORK.

In consideration of the performance of the work as set forth in these Contract Documents, the Owner agrees to pay to the Contractor the amount bid in the Proposal as adjusted in accordance with the Contract Documents, or as otherwise herein provided, and to make such payments in the manner and at the times provided in the Contract Documents.

The Contractor agrees to complete the work within one hundred & eighty (180) days and to accept as full payment hereunder the amounts computed as determined by the Contract Documents and based on the said BID.

The Contractor agrees to remedy all defects appearing in the work or developing in the materials furnished and the workmanship performed under this Contract during the warranty period after the date of final acceptance of the work by the Owner, and further agrees to indemnify and save the Owner harmless from any costs encountered in remedying such defects.

It is agreed that the Contract, based upon the BID, shall be fully complete within the stated number of consecutive calendar days from the date the Notice to Proceed is issued.

In the event the Contractor fails to complete the work within the time limit or extended time limit agreed upon, as more particularly set forth in the Contract Documents, liquidated damages shall be paid at a rate of \$500 per day. Sundays and legal holidays shall be included in determining days in default.

This contract will automatically expire upon completion of the project.

IN WITNESS WHEREOF, we, the parties hereto, each herewith subscribe the same this

\_\_\_\_\_ day of \_\_\_\_\_, A.D., 2013.

CITY OF KEY WEST

By \_\_\_\_\_

Title \_\_\_\_\_

CONTRACTOR

By \_\_\_\_\_

Title \_\_\_\_\_

APPROVED AS TO FORM

\_\_\_\_\_  
Attorney for Owner

\* \* \* \*

**FLORDIA PERFORMANCE BOND**

BOND NO. \_\_\_\_\_

AMOUNT: \$ \_\_\_\_\_

**KNOW ALL MEN BY THESE PRESENTS**, that in accordance with Florida Statutes Section 255.05 \_\_\_\_\_

with offices at \_\_\_\_\_ hereinafter called the CONTRACTOR (Principal), and

\_\_\_\_\_ with offices at \_\_\_\_\_ a corporation duly organized and existing under and by virtue of the laws of the State of Florida, hereinafter called the SURETY, and authorized to transact business within the State of Florida, as SURETY, are held and firmly bound unto the **CITY OF KEY WEST**, hereinafter called the CITY (Obligee), in the sum of:

\_\_\_\_\_ DOLLARS (\$ \_\_\_\_\_), lawful money of the United States of America, for the payment of which, well and truly be made to the CITY, the CONTRACTOR and the SURETY bind themselves and each of their heirs, executors, administrators, successors, and assigns, jointly and severally, firmly by these presents as follows:

**THE CONDITION OF THE ABOVE OBLIGATION IS SUCH THAT:**

**WHEREAS**, the CONTRACTOR has executed and entered into a certain Contract hereto attached, with the CITY, dated \_\_\_\_\_, 2013, to furnish at his own cost, charges, and expense all the necessary materials, equipment, and/or labor in strict and express accordance with said Contract and the Contract Documents as defined therein, all of which is made a part of said Contract by certain terms and conditions in said Contract more particularly mentioned, which Contract, consisting of the various Contract Documents is made a part of this Bond as fully and completely as if said Contract Documents were set forth herein;

**NOW THEREFORE**, the conditions of this obligation are such that if the above bounden CONTRACTOR:

1. Shall in all respects comply with the terms and conditions of said Contract and his obligation there under, including the Contract Documents (which include the scope of work and conditions as prepared by the CITY, invitation to bid, instructions to bidders, the CONTRACTOR'S bid as accepted by the above CITY, the bid and contract performance and payment bonds, and all addenda, if any, issued prior to the opening of bids), being made a part of this bond by reference, at the times and in the manner prescribed in the contract; and



2. Promptly makes payments to all claimants, as defined in Section 255.05(1), Florida Statutes, supplying PRINCIPAL with labor, materials, or supplies, used directly or indirectly by PRINCIPAL in the prosecution of the work provided for in the contract; and

3. Pays CITY all losses, costs, expenses, damages, attorney's fees, including appellate proceedings, injury or loss of whatever kind and however arising including, without limitation, delay damages to which said CITY may be subject by reason of any wrongdoing, misconduct, want of care or skill, negligence, failure of performance, breach, failure to petition within the prescribed time, or default, including patent infringements, on the part of said CONTRACTOR, his agents or employees, in the execution or performance of said Contract; and

4. Performs the guarantee of all work and materials furnished under the contract for the time specified in the contract, then this obligation shall be void; otherwise, to remain in full force and effect for the term of said Contract.

**AND**, the said Surety for value received, hereby stipulates and agrees that no change involving any extension of time, or addition to the terms of the Contract Documents, or to the work to be performed, or materials to be furnished there under shall affect said obligation of said Surety on this Bond, and the said Surety does hereby waive notice of any such changes, extension of time, alterations, or additions of the terms of the Contract Documents, or to the work.

Any action instituted by a claimant under this bond for payment must be in accordance with the notice and time limitation provisions in Section 255.05(2), Florida Statutes.

**IN WITNESS WHEREOF**, the above parties bonded together have executed this instrument

this \_\_\_\_\_ day of \_\_\_\_\_, 2013, the name and corporate seal of each corporate party being hereto affixed and those presents duly signed by its undersigned representative, pursuant to authority of its governing body.

**CONTRACTOR**

By: \_\_\_\_\_

(SEAL)

ATTEST

**SURETY**

By: \_\_\_\_\_

(SEAL)

ATTEST

**FLORIDA PAYMENT BOND**

BOND NO. \_\_\_\_\_

AMOUNT: \$ \_\_\_\_\_

**KNOW ALL MEN BY THESE PRESENTS**, that in accordance with Florida Statutes Section 255.05, \_\_\_\_\_

with offices at \_\_\_\_\_  
hereinafter called the CONTRACTOR, (Principal), and

\_\_\_\_\_

with offices at \_\_\_\_\_

a corporation duly organized and existing under and by virtue of the laws of the State of \_\_\_\_\_

\_\_\_\_\_, hereinafter called the SURETY, and authorized to transact business within the State of Florida, as SURETY, are held and firmly bound unto CITY OF KEY WEST, hereinafter called the City (Obligee), in the sum of:

\_\_\_\_\_ DOLLARS( \_\_\_\_\_),  
lawful money of the United States of America, for the payment of which, well and truly be made to the CITY, and the CONTRACTOR and the SURETY bind themselves and each of their heirs, executors, administrators, successors, and assigns, jointly and severally, firmly by these presents as follows:

**THE CONDITION OF THE ABOVE OBLIGATION IS SUCH THAT:**

**WHEREAS**, the CONTRACTOR has executed and entered into a certain Contract for

**ITB 13-002 CONSTRUCT KEY WEST CEMETERY MAUSOLEUMS CE1003** attached hereto, with the CITY, dated

\_\_\_\_\_, 2013, to furnish at his own cost, charges, and expense the necessary materials, equipment, and/or labor in strict and express accordance with said Contract and the plans, drawings (if any), and specifications prepared by the CITY, all of which is made a part of said Contract by certain terms and conditions in said Contract more particularly mentioned, which Contract, consisting of the various Contract Documents specifically mentioned herein and relative hereto, is made a part of this Bond as fully and completely as if said Contract Documents were set forth herein.

**NOW THEREFORE**, the conditions of this obligation are such that if the above bounden CONTRACTOR shall in all respects comply with the terms and conditions of said Contract and his obligation thereunder, including the Contract Documents, which include Scope of work and conditions prepared by the CITY, invitation to bid, instructions to bidders, the

CONTRACTOR'S bid as accepted by the CITY, the bid and contract and payment bonds, and all addenda, if any, issued prior to the opening of bids), and further that if said CONTRACTOR shall promptly make payments to all persons supplying materials, equipment, and/or labor, used directly or indirectly by said CONTRACTOR or subcontractors in the prosecution of the work for said contract in accordance with Florida Statutes, Section 255.05 or Section 713.23, then this obligation shall be void; otherwise to remain in full force and effect for the term of said contract, including and all guarantee periods as specifically mentioned in said Contract Documents.

**AND**, the said SURETY for value received, hereby stipulates and agrees that no change involving any extension of time, or addition to the terms of the Contract or to the work to be performed, or materials to be furnished thereunder, or in the Contract Documents and specifications accompanying the said contract shall affect said obligation of said SURETY on this Bond, and the said SURETY does hereby waive notice of any such changes, extension of time, alternations, or additions of the terms of the Contract, or to the work, to the Contract Documents, or to the specifications.

Claimant shall give written notice to the CONTRACTOR and the SURETY as required by Section 255.05 or Section 713.23, Florida Statutes. Any action instituted against the CONTRACTOR or SURETY under this bond for payment must be in accordance with the notice and time limitation provisions in Section 255.05(2) or Section 713.23, Florida Statutes.

**IN WITNESS WHEREOF**, the above parties bounded together have executed this instrument

this \_\_\_\_\_ day of \_\_\_\_\_, 2013, the name and corporate seal of each corporate party being hereto affixed and those presents duly signed by its undersigned representative, pursuant to authority of its governing body.

**CONTRACTOR**

By: \_\_\_\_\_

(SEAL)

ATTEST

**SURETY**

By: \_\_\_\_\_

(SEAL)

ATTEST

---

---

**PART 3**

**CONDITIONS OF THE CONTRACT**

---

---

GENERAL CONDITIONS  
CONTENTS

Article

DEFINITIONS

1. AS APPROVED
2. AS SHOWN, AND AS INDICATED
3. BIDDER
4. CONTRACT DOCUMENTS
5. CONTRACTOR
6. CONTRACT COMPLETION
7. DAYS
8. DRAWINGS
9. ENGINEER
10. NOTICE
11. OR EQUAL
12. OWNER
13. PLANS
14. SPECIFICATIONS
15. NOTICE TO PROCEED
16. SUBSTANTIAL COMPLETION
17. WORK

CONTRACT DOCUMENTS

18. INTENT OF CONTRACT DOCUMENTS
19. DISCREPANCIES AND OMISSIONS
20. CHANGES IN THE WORK
21. EXAMINATION AND VERIFICATION  
OF CONTRACT DOCUMENTS
22. DOCUMENTS TO BE KEPT  
ON THE JOBSITE
23. ADDITIONAL CONTRACT  
DOCUMENTS
24. OWNERSHIP OF CONTRACT  
DOCUMENTS

THE ENGINEER

25. AUTHORITY OF THE ENGINEER
26. DUTIES AND RESPONSIBILITIES  
OF THE ENGINEER
27. LIMITATIONS ON ENGINEER'S  
RESPONSIBILITIES
28. REJECTED WORK
29. LINES AND GRADES
30. SUBMITTALS
31. DETAIL DRAWINGS AND INSTRUCTIONS

THE CONTRACTOR AND HIS EMPLOYEES

32. CONTRACTOR, AN INDEPENDENT AGENT
32. (a) ASSIGNMENT OF CONTRACT

33. SUBCONTRACTING
34. INSURANCE AND LIABILITY
  - A. GENERAL
  - B. CONTRACTOR AND SUB-  
CONTRACTOR INSURANCE
  - C. COMPENSATION AND EMPLOYER'S  
LIABILITY INSURANCE
  - D. GENERAL LIABILITY INSURANCE  
(INCLUDING AUTOMOBILE)
  - E. BUILDER'S RISK ALL RISK  
INSURANCE
  - F. NO PERSONAL LIABILITY OF PUBLIC  
OFFICIALS
35. INDEMNITY
36. EXCLUSION OF CONTRACTOR CLAIMS
37. TAXES AND CHARGES
38. REQUIREMENTS OF STATE LAW FOR  
PUBLIC WORKS PROJECTS
39. CODES, ORDINANCES, PERMITS,  
AND LICENSES
40. SUPERINTENDENCE
41. RECEPTION OF ENGINEER'S  
COMMUNICATIONS
42. SAFETY
43. PROTECTION OF WORK AND PROPERTY
44. RESPONSIBILITY OF CONTRACTOR TO ACT  
IN AN EMERGENCY
45. MATERIALS AND APPLIANCES
46. CONTRACTORS' AND MANUFACTURERS'  
COMPLIANCE WITH STATE SAFETY,  
OSHA AND OTHER CODE REQUIREMENTS
47. SUBSTITUTION OF MATERIALS
48. TESTS, SAMPLES, AND OBSERVATIONS
49. ROYALTIES AND PATENT
50. CONTRACTOR'S RIGHT TO  
TERMINATE CONTRACT
51. CORRECTION OF DEFECTIVE WORK  
DURING WARRANTY PERIOD

PROGRESS OF THE WORK

52. BEGINNING OF THE WORK
53. SCHEDULES AND PROGRESS REPORTS
54. PROSECUTION OF THE WORK
55. OWNER'S RIGHT TO RETAIN  
IMPERFECT WORK
56. OWNER'S RIGHT TO DO WORK
57. OWNER'S RIGHT TO TRANSFER  
EMPLOYMENT
58. DELAYS AND EXTENSION OF TIME
59. DIFFERING SITE CONDITION

**Article**

- 60. LIQUIDATED DAMAGES
- 61. OTHER CONTRACTS
- 62. USE OF PREMISES
- 63. SUBSTANTIAL COMPLETION DATE
- 64. PERFORMANCE TESTING
- 65. OWNER'S USE OF PORTION OF THE WORK
- 66. CUTTING AND PATCHING
- 67. CLEANING UP

**PAYMENT**

- 68. CHANGE ORDERS
  - A. UNIT PRICE
  - B. LUMP SUM
  - C. COST REIMBURSEMENT  
WORK
- 69. PARTIAL PAYMENTS
  - A. GENERAL
  - B. ESTIMATE
  - C. DEDUCTION FROM ESTIMATE
  - D. QUALIFICATIONS FOR  
PARTIAL PAYMENT FOR  
MATERIALS DELIVERED
  - E. PAYMENT
- 70. CLAIMS FOR EXTRA WORK
- 71. RELEASE OF LIENS OR CLAIMS
- 72. FINAL PAYMENT
- 73. NO WAIVER OF RIGHTS
- 74. ACCEPTANCE OF FINAL PAYMENT  
CONSTITUTES RELEASE

\*\*\*\*\*

## **DEFINITIONS**

Whenever in the Contract Documents the following terms are used, the intent and meaning shall be interpreted as follows:

### **1. AS APPROVED**

The words “as approved”, unless otherwise qualified, shall be understood to be followed by the words “by the ENGINEER for conformance with the Contract Document”.

### **2. AS SHOWN, AND AS INDICATED**

The words “as shown” and “as Indicated” shall be understood to be followed by the words “on the Drawings”.

### **3. BIDDER**

The person or persons, partnership, firm, or corporation submitting a Proposal for the work contemplated.

### **4. CONTRACT DOCUMENTS**

The “Contract Documents” consist of the Bidding Requirements, Contract Forms, Conditions of the Contract, Specifications, Drawings, all modifications thereof incorporated into the Documents before their execution, Change Orders, and all other requirements incorporated by specific reference thereto. These form the Contract.

### **5. CONTRACTOR**

The person or persons, partnership, firm, or corporation who enters into the Contract awarded him by the OWNER.

### **6. CONTRACT COMPLETION**

The “Contract Completion” is the date the OWNER accepts the entire work as being in compliance with the Contract Documents, or formally waives nonconforming work to extent of nonconformity, and issues the final payment in accordance with the requirements set forth in Article, “Final Payment” of these General Conditions.

### **7. DAYS**

Unless otherwise specifically stated, the term “days” will be understood to mean calendar days. Business day or working day means any day other than Saturday, Sunday, or legal holiday.

### **8. DRAWINGS**

The term “Drawings” refers to the official Drawings, Profiles, cross sections, elevations, details, and other working drawings and supplementary drawings, or reproductions thereof, signed by the ENGINEER, which shows the location, character, dimensions, and details of the work to be performed. Drawings may either be bound in the same book as the balance of the Contract Documents, or bound in separate sets, and are a part of the Contract Documents, regardless of the method of binding.

### **9. ENGINEER**

The person or organization identified as such in the Contract Documents. The Term “ENGINEER” means ENGINEER or his authorized representative.

### **10. NOTICE**

The term “notice” or the requirement to notify, as used in the Contract Documents or applicable state or federal statutes, shall signify a written communication delivered in person or by registered mail to the individual, or to a member of the firm, or to an officer of the corporation for whom it is intended. Certified or registered mail shall be addressed to the last business address known to him who gives the notice.

### **11. OR EQUAL**

The term “or equal” shall be understood to indicate that the “equal” Product is equivalent to or better than the Product named in function, performance, reliability, quality, and general configuration. Determination of equality in reference to the Project design requirements will be made by the ENGINEER. Such equal Products shall not be purchased or installed by the CONTRACTOR without written authorization.

### **12. OWNER**

The person, organization, or public body identified as such in the Contract Documents.

### **13. PLANS (See Drawings)**

### **14. SPECIFICATIONS**

The term “Specifications” refers to those portions of the Contract Documents consisting of written technical descriptions of materials, equipment, construction systems, standards, and workmanship as applied to the work and certain

administrative details applicable thereto. Where standard specifications, such as those of ASTM, AASHTO, etc., have been referred to, the applicable portions of such standard specifications shall become a part of these Contract Documents. If referenced specifications conflict with specifications contained herein, the requirements contained herein shall prevail.

#### **15. NOTICE TO PROCEED**

A written notice given by the OWNER to the CONTRACTOR (with a copy to the ENGINEER) fixing the date on which the Contract time will commence to run and on which the CONTRACTOR shall start to perform his obligation under the Contract Documents. The Notice to Proceed will be given within 30 days following the execution of the Contract by the OWNER.

#### **16. SUBSTANTIAL COMPLETION**

“Substantial Completion” shall be that degree of completion of the Project or a defined portion of the Project, as evidenced by the ENGINEER’s written notice of Substantial Completion, sufficient to Provide the OWNER, at his discretion, the full-time use of the Project or defined portion of the Project for the purposes for which it was intended. “Substantial Completion” of an operating facility shall be that degree of completion that has Provided a minimum of 7 continuous days of successful, trouble-free, operation, which period shall begin after all performance and acceptance testing has been successfully demonstrated to the ENGINEER. All equipment contained in the work, plus all other components necessary to enable the OWNER to operate the facility in a manner that was intended, shall be complete on the substantial completion date.

#### **17. WORK**

The word “work” within these Contract Documents shall include all material, labor, tools, and all appliances, machinery, transportation, and appurtenances necessary to perform and complete the Contract, and such additional items not specifically indicated or described which can be reasonably inferred as belonging to the item described or indicated and as required by good Practice to Provide a complete and satisfactory system or structure. As used herein, “Provide” shall be understood to mean “furnish and install, complete in-place”.

#### **CONTRACT DOCUMENTS**

#### **18. INTENT OF CONTRACT DOCUMENTS**

The Contract Documents are complementary, and what is called for by one shall be as binding as if called for by all. The

intent of the Documents is to describe a functionally complete Project (or part thereof) to be constructed in accordance with the Contract Documents. Any work, materials, or equipment that may reasonably be inferred from the Contract Documents as being required to produce the intended result shall be supplied whether or not specifically called for. When words which have a well-known technical or trade meaning are used to describe work, materials, or equipment, such words shall be interpreted in accordance with that meaning.

Reference to standard specifications, manuals, or codes of any technical society, organization or association, or to the laws or regulations of any governmental authority, whether such reference be specific or by implication, shall mean the latest standard specification, manual, code or laws or regulations in effect on the first published date of the Invitation to Bid, except as may be otherwise specifically stated. However, no Provision of any referenced standard specification, manual or code (whether or not specifically incorporated by reference in the Contract Documents) shall be effective to change the duties and responsibilities of OWNER, CONTRACTOR, or ENGINEER, or any of their consultants, agents, or employees from those set forth in the Contract Documents, nor shall it be effective to assign to ENGINEER, or any ENGINEER’s consultants, agents, or employees, any duty or authority to supervise or direct the furnishing or performance of the work or any duty or authority to undertake responsibility contrary to the Provisions of Article LIMITATIONS ON ENGINEER’S RESPONSIBILITIES.

#### **19. DISCREPANCIES AND OMISSIONS**

Any discrepancies or omissions found in the Contract Documents shall be reported to the ENGINEER immediately. The ENGINEER will clarify discrepancies or omissions, in writing, within a reasonable time.

In resolving inconsistencies among two or more sections of the Contract Documents, Precedence shall be given in the following order:

- A. CONTRACT
- B. PROPOSAL
- C. SUPPLEMENTARY CONDITIONS
- D. INVITATION TO BID
- E. INSTRUCTIONS TO BIDDERS
- F. GENERAL CONDITIONS
- G. SPECIFICATIONS
- H. DRAWINGS

Addenda shall take Precedence over all sections referenced therein. Figure dimensions on Drawings shall take precedence over scale dimensions. Detailed Drawings shall take precedence over general Drawings.



## **20. CHANGES IN THE WORK**

The OWNER, without notice to the Sureties and without invalidating the Contract, may order changes in the work within the general scope of the Contract by altering, adding to, or deducting from the work, the Contract being adjusted accordingly. All such work shall be executed under the conditions of the original Contract, except as specifically adjusted at the time of ordering such change.

In giving instructions, the ENGINEER may order minor changes in the work not involving extra cost and not inconsistent with the purposes of the Project, but otherwise, except in an emergency endangering life and Property, additions or deductions from the work shall be performed only in pursuance of an approved Change Order from the OWNER, countersigned by the ENGINEER.

If the work is reduced by alterations, such action shall not constitute a claim for damages based on loss of anticipated Profits.

## **21. EXAMINATION AND VERIFICATION OF CONTRACT DOCUMENTS**

The CONTRACTOR shall thoroughly examine and become familiar with all of the various parts of these Contract Documents and determine the nature and location of the work, the general and local conditions, and all other matters, which can in any way affect the work under this Contract. Failure to make an examination necessary for this determination shall not release the CONTRACTOR from the obligations of this Contract. No verbal agreement or conversation with any officer, agent, or employee of the OWNER or with the ENGINEER either before or after the execution of this Contract shall affect or modify any of the terms or obligations herein contained.

## **22. DOCUMENTS TO BE KEPT ON THE JOBSITE**

The CONTRACTOR shall keep one copy of the Contract Documents on the job- site, in good order, available to the ENGINEER and to his representatives.

The CONTRACTOR shall maintain on a daily basis at the jobsite, and make available to the ENGINEER on request, one current record set of the Drawings which have been accurately marked to indicate all modifications in the completed work that differ from the design information shown on the Drawings. Upon Substantial completion of the work, the CONTRACTOR shall give the ENGINEER one complete set of these marked up record Drawings.

## **23. ADDITIONAL CONTRACT DOCUMENTS**

Copies of Contract Documents or Drawings may be obtained on request from the ENGINEER and by paying the actual cost of reproducing the Contract Documents or Drawings.

## **24. OWNERSHIP OF CONTRACT DOCUMENTS**

All portions of the Contract Documents, and copies thereof furnished by the ENGINEER are instruments of service for this Project. They are not to be used on other work and are to be returned to the ENGINEER on request at the completion of the work. Any reuse of these materials without specific written verification or adaptation by the ENGINEER will be at the risk of the user and without liability or legal expense to the ENGINEER. Such user shall hold the ENGINEER harmless from any and all damages, including reasonable attorneys' fees, from any and all claims arising from any such reuse. Any such verification and adaptation shall entitle the ENGINEER to further compensation at rates to be agreed upon by the user and the ENGINEER.

## **THE ENGINEER**

### **25. AUTHORITY OF THE ENGINEER**

The ENGINEER will be the OWNER's representative during the construction period. His authority and responsibility will be limited to the Provisions set forth in these Contract Documents. The ENGINEER will have the Authority to reject work that does not conform to the Contract Documents. However, neither the ENGINEER's authority to act under this Provision, nor any decision made by him in good faith either to exercise or not to exercise such authority, shall give rise to any duty or responsibility of the ENGINEER to the CONTRACTOR, any SUBCONTRACTOR, their respective Sureties, any of their agents or employees, or any other person performing any of the work.

### **26. DUTIES AND RESPONSIBILITIES OF THE ENGINEER**

The ENGINEER will make visits to the site at intervals appropriate to the various stages of construction to observe the Progress and quality of the work and to determine, in general, if the work is proceeding in accordance with the intent of the Contract Documents. He will not make comprehensive or continuous review or observation to check quality or quantity of the work, and he will not be responsible for construction means, methods, techniques, sequences, or Procedures, or for safety Precautions and Programs in connection with the work. Visits and observations made by the ENGINEER shall not relieve the CONTRACTOR of his obligation to conduct

comprehensive inspections of the work and to furnish materials and perform acceptable work, and to provide adequate safety Precautions, in conformance with the intent of the Contract.

The ENGINEER will make recommendations to the OWNER, in writing, on all claims of the OWNER or the CONTRACTOR arising from interpretation or execution of the Contract Documents. Such recommendations will be of factual and/or technical nature, and will not include the legal interpretation of the Contract Documents. Any necessary legal interpretation of the Contract Document will be made by the OWNER. Such recommendation shall be necessary before the CONTRACTOR can receive additional money under the terms of the Contract. Changes in work ordered by the ENGINEER shall be made in compliance with Article CHANGES IN THE WORK.

One or more Project representatives may be assigned to observe the work. It is understood that such Project representatives shall have the authority to issue notice of nonconformance and make decisions within the limitations of the authority of the ENGINEER. The CONTRACTOR shall furnish all reasonable assistance required by the ENGINEER or Project representatives for Proper observation of the work. The above-mentioned Project representatives shall not relieve the CONTRACTOR of his obligations to conduct comprehensive inspections of the work and to furnish materials and perform acceptable work, and to provide adequate safety Precautions, in conformance with the intent of the Contract.

#### **27. LIMITATIONS ON ENGINEER'S RESPONSIBILITIES**

ENGINEER will not be responsible for CONTRACTOR's means, methods, techniques, sequences, or Procedures of construction, or the safety Precautions and Programs incident thereto, and ENGINEER will not be responsible for CONTRACTOR's failure to perform or furnish the work in accordance with the Contract Documents.

ENGINEER will not be responsible for the acts or omissions of CONTRACTOR or of any SUBCONTRACTOR, any supplier, or of any other person or organization performing or furnishing any of the work.

Whenever in the Contract Documents the terms "as ordered", "as directed", "as required", "as allowed", "as approved", or terms of like effect or import are used, or the adjectives "reasonable", "suitable", "acceptable", "Proper", or "satisfactory", or adjectives of like effect or import are used to describe a requirement, direction, review or judgment of ENGINEER as to the work, it is intended that such

requirement, direction, review or judgment will be solely to evaluate the work for compliance with the Contract Documents (unless there is a specific statement indicating otherwise). The use of any such term or adjective shall not be effective to assign to ENGINEER any duty or authority to supervise or direct the furnishing or performance of the work or any duty or authority to undertake responsibility contrary to the Provisions of this Article.

#### **28. REJECTED WORK**

Any defective work or nonconforming materials or equipment that may be discovered at any time prior to expiration of the warranty period shall be removed and replaced by work which shall conform to the Provisions of the Contract Documents. Any material condemned or rejected shall be removed at once from the Project site.

Failure on the part of the ENGINEER to condemn or reject bad or inferior work or to note nonconforming materials or equipment on CONTRACTOR submittals shall not be construed to imply acceptance of such work. The OWNER shall reserve and retain all of its rights and remedies at law against the CONTRACTOR and its Surety for correction of any and all latent defects discovered after the guarantee period.

#### **29. LINES AND GRADES**

Lines and grades shall be established as provided in the supplementary conditions. All stakes, marks, and other reference information shall be carefully preserved by the CONTRACTOR, and in case of their careless or unnecessary destruction or removal by him or his employees, such stakes, marks, and other information shall be replaced at the CONTRACTOR's expense.

#### **30. SUBMITTALS**

After checking and verifying all field measurements and after complying with applicable Procedures specified in Division I, GENERAL REQUIREMENTS, CONTRACTOR shall submit to ENGINEER, in accordance with the schedule for submittals for review, shop drawings, electrical diagrams, and catalog cuts for fabricated items and manufactured items (including mechanical and electrical equipment), which shall bear a stamp or specific written indication that CONTRACTOR has satisfied CONTRACTOR's responsibilities under the Contract Documents with respect to the review of the submittal. All submittals shall be identified as ENGINEER may require. The data shown shall be complete with respect to quantities, dimensions specified, performance and design criteria, materials, and similar data to enable ENGINEER to review the information. CONTRACTOR shall also submit to ENGINEER for review, with such Promptness as to cause no

delay in work, all samples required by the Contract Documents. All samples shall have been checked by and accompanied by a specific written indication that CONTRACTOR has satisfied CONTRACTOR's responsibilities under the Contract Documents with respect to the review of the submission and shall be identified clearly as to material, supplier, pertinent data such as catalog numbers and the use for which intended.

Before submission of each submittal, CONTRACTOR shall have determined and verified all quantities, dimensions, specified performance criteria, installation requirements, materials, catalog numbers, and similar data with respect thereto and reviewed or coordinated each submittal with other submittals and with the requirements of the work and the Contract Documents.

At the time of each submission, CONTRACTOR shall give ENGINEER specific written notice of each variation that the submittal may have from the requirements of the Contract Documents, and, in addition, shall cause a specific notation to be made on each shop drawing submitted to ENGINEER for review and approval of each variation.

ENGINEER will review submittals with reasonable Promptness, but ENGINEER's review will be only for conformance with the design concept of the Project and for compliance with the information given in the Contract Documents and shall not extend to means, methods, techniques, sequences, or Procedures of construction (except where a specific means, method, technique, sequence, or Procedure of construction is indicated in or required by the Contract Documents) or to safety Precautions or Programs incident thereto. The review of a separate item as such will not indicate review of the assembly in which the item functions. CONTRACTOR shall make corrections required by ENGINEER, and shall return the required number of corrected copies of shop drawings and submit as required new samples for review. CONTRACTOR shall direct specific attention in writing to revisions other than the corrections called for by ENGINEER on Previous submittals.

ENGINEER's review of submittals shall not relieve CONTRACTOR from the responsibility for any variation from the requirements of the Contract Documents unless CONTRACTOR has in writing called ENGINEER's attention to each such variation at the time of submission and ENGINEER has given written approval of each such variation by a specific written notation thereof incorporated therein or accompanying the shop drawing or sample approval; nor will any approval by ENGINEER relieve CONTRACTOR from responsibility for errors or omissions in the shop drawings or from responsibility for having complied with the Provisions herein.

Where a shop drawing or sample is required by the

specifications, any related work performed Prior to ENGINEER's review and approval of the pertinent submission shall be at the sole expense and responsibility of the CONTRACTOR.

### **31. DETAIL DRAWINGS AND INSTRUCTIONS**

The ENGINEER will furnish, with reasonable Promptness, additional instructions by means of Drawings or otherwise, if, in the ENGINEER's opinion, such are required for the Proper execution of the work. All such Drawings and instructions will be consistent with the Contract Documents, true developments thereof, and reasonably inferable there from.

### **THE CONTRACTOR AND HIS EMPLOYEES**

#### **32. CONTRACTOR, AN INDEPENDENT AGENT**

The CONTRACTOR shall independently perform all work under this Contract and shall not be considered as an agent of the OWNER or of the ENGINEER, nor shall the CONTRACTOR's SUBCONTRACTORS or employees be subagents of the OWNER or of the ENGINEER.

#### **32. (a) ASSIGNMENT OF CONTRACT**

Assignment of any part or the whole of this Contract shall be subject to review and approval of the City Commission.

#### **33. SUBCONTRACTING**

Unless modified in the Supplementary Conditions, within 10 days after the execution of the Contract, the CONTRACTOR shall submit to the ENGINEER the names of all SUBCONTRACTORS Proposed for the work, including the names of any SUBCONTRACTORS that were submitted with the Proposal. The CONTRACTOR shall not employ any SUBCONTRACTORS to which the OWNER may object to as lacking capability to properly perform work of the type and scope anticipated.

The CONTRACTOR is as fully responsible to the OWNER for the acts and omissions of his SUBCONTRACTORS and of persons either directly or indirectly employed by them as he is for the acts and omissions of persons directly employed by him.

Nothing contained in the Contract Documents shall create any contractual relationship between any SUBCONTRACTOR and the OWNER or ENGINEER.

#### **34. INSURANCE AND LIABILITY**

**A. GENERAL**

The CONTRACTOR shall provide (from insurance companies acceptable to the OWNER) the insurance coverage designated hereinafter and pay all costs before commencing work under this Contract. The CONTRACTOR shall furnish the OWNER with certificates of insurance specified herein showing the type, amount class of operations covered, effective dates, and date of expiration of policies, and containing substantially the following statement:

“The insurance covered by this certificate shall not be canceled or materially altered, except after 30 days’ written notice has been received by the OWNER.”

In case of the breach of any Provision of this Article, the OWNER, at his option, may take out and maintain, at the expense of the CONTRACTOR, such insurance as the OWNER may deem Proper and may deduct the cost of such insurance from any monies which may be due or become due the CONTRACTOR under this Contract.

**B. CONTRACTOR AND SUBCONTRACTOR INSURANCE**

The CONTRACTOR shall not commence work under this Contract until he has obtained all the insurance required hereunder and such insurance has been reviewed by the OWNER, nor shall the CONTRACTOR allow any SUBCONTRACTOR to commence work on his subcontract until insurance specified below has been obtained. Review of the insurance by the OWNER shall not relieve or decrease the liability of the CONTRACTOR hereunder.

**C. COMPENSATION AND EMPLOYER’S LIABILITY INSURANCE**

The CONTRACTOR shall maintain during the life of this Contract the statutory amount of Workmen’s Compensation Insurance, in addition, Employer’s Liability Insurance in an amount as specified in the Supplementary Conditions, for each occurrence, for all of his employees to be engaged in work on the Project under this Contract. In case any such work is subcontracted, the CONTRACTOR shall require the SUBCONTRACTOR to provide similar Workmen’s Compensation and Employer’s Liability Insurance for all of the SUBCONTRACTOR’s employees to be engaged in such work.

**D. GENERAL LIABILITY INSURANCE (INCLUDING AUTOMOBILE)**

The CONTRACTOR shall maintain during the life of this Contract such general liability, completed operations and Products liability, and automobile liability insurance as will

Provide coverage for claims for damages for personal injury, including accidental death, as well as for claims for Property damage, which may arise directly or indirectly from performance of the work under this Contract. The general liability policy shall include contractual liability assumed by the CONTRACTOR under Article **INDEMNITY**. Coverage for Property damage shall be on a “broad form” basis with no exclusions for “X, C & U”. The amount of insurance to be provided shall be as specified in the Supplementary Conditions.

In the event any work under this Contract is performed by a SUBCONTRACTOR, the CONTRACTOR shall be responsible for any liability directly or indirectly arising out of the work performed by the SUBCONTRACTOR; to the extent such liability is not covered by the SUBCONTRACTOR’s insurance.

The OWNER and ENGINEER, their officers, agents, and employees shall be named as Additional Insured’s on the CONTRACTOR’s and any SUBCONTRACTOR’s general liability and automobile liability insurance policies for any claims arising out of work performed under this Contract.

**E. BUILDERS RISK ALL RISK INSURANCE**

Unless otherwise modified in the Supplementary Conditions, the CONTRACTOR shall secure and maintain during the life of this Contract, Builders Risk All Risk Insurance coverage in an amount equal to the full value of the facilities under construction. Such insurance shall include coverage for earthquake, landslide, flood, collapse, loss due to the results of faulty workmanship or design, and all other normally covered risks, and shall provide for losses to be paid to the CONTRACTOR, OWNER, and ENGINEER as their interests may appear.

The OWNER and ENGINEER, their officers, agents, and employees shall be named as additional insured’s on the CONTRACTOR’s and any SUBCONTRACTOR’s Builders Risk All Risk insurance policies for any claims arising out of work performed under this Contract.

This insurance shall include a waiver of subrogation as to the ENGINEER, the OWNER, the CONTRACTOR, and their respective officers, agents, employees and SUBCONTRACTORS.

**F. NO PERSONAL LIABILITY OF PUBLIC OFFICIALS**

In carrying out any of the Provisions hereof in exercising any authority granted by the Contract, there will be no personal liability upon any public official.

**35. INDEMNITY**

To the maximum extent permitted by law, the CONTRACTOR shall indemnify and defend the OWNER and the ENGINEER, and their officers, employees, agents, and sub-consultants, from all claims and losses, including attorney’s fees and litigation costs arising out of Property losses or health, safety, personal injury, or death claims by the CONTRACTOR, its SUBCONTRACTORS of any tier, and their employees, agents, or invitees regardless of the fault, breach of Contract, or negligence of the OWNER or ENGINEER, excepting only such claims or losses that have been adjudicated to have been caused solely by the negligence of the OWNER or the ENGINEER and regardless of whether or not the CONTRACTOR is or can be named a party in a litigation.

**36. EXCLUSION OF CONTRACTOR CLAIMS**

In performing its obligations, the ENGINEER and its consultants may cause expense for the CONTRACTOR or its SUBCONTRACTORS and equipment or material suppliers. However, those parties and their sureties shall maintain no direct action against the ENGINEER, its officers, employees, agents, and consultants for any claim arising out of, in connection with, or resulting from the engineering services performed or required to be performed.

**37. TAXES AND CHARGES**

The CONTRACTOR shall withhold and pay any and all sales and use taxes and all withholding taxes, whether State or Federal, and pay all Social Security charges and also all State Unemployment Compensation charges, and pay or cause to be withheld, as the case may be, any and all taxes, charges, or fees or sums whatsoever, which are now or may hereafter be required to be paid or withheld under any laws.

**38. REQUIREMENTS OF STATE LAW FOR PUBLIC WORKS PROJECTS**

When the Contract Documents concern public works of the state or any county, municipality, or political subdivision created by its laws, the applicable statutes shall apply. All parties to this Contract shall determine the contents of all applicable statutes and comply with their Provisions throughout the performance of the Contract.

**39. CODES, ORDINANCES, PERMITS AND LICENSES**

The CONTRACTOR shall keep himself fully informed of all

local codes and ordinances, as well as state and federal laws, which in any manner affect the work herein specified. The CONTRACTOR shall at all times comply with said codes and ordinances, laws, and regulations, and Protect and indemnify the OWNER, the ENGINEER and their respective employees, and its officers and agents against any claim or liability arising from or based on the violation of any such laws, ordinances, or regulations. All permits, licenses and inspection fees necessary for Prosecution and completion of the work shall be secured and paid for by the CONTRACTOR, unless otherwise specified.

**40. SUPERINTENDENCE**

The CONTRACTOR shall keep at the project site, competent supervisory personnel. The CONTRACTOR shall designate, in writing, before starting work, a Project superintendent who shall be an employee of the CONTRACTOR and shall have complete authority to represent and to act for the CONTRACTOR. ENGINEER shall be notified in writing prior to any change in superintendent assignment. The CONTRACTOR shall give efficient supervision to the work, using his best skill and attention. The CONTRACTOR shall be solely responsible for all construction means, methods, techniques, and Procedures, and for providing adequate safety Precautions and coordinating all portions of the work under the Contract. It is specifically understood and agreed that the ENGINEER, its employees and agents, shall not have control or charge of and shall not be responsible for the construction means, methods, techniques, Procedures, or for providing adequate safety Precautions in connection with the work under Contract.

**41. RECEPTION OF ENGINEER’S COMMUNICATIONS**

The superintendent shall receive for the CONTRACTOR all communications from the ENGINEER. Communications of major importance will be confirmed in writing upon request from the CONTRACTOR.

The ENGINEER may schedule Project meetings for the purposes of discussing and resolving matters concerning the various elements of the work. Time and place for these meetings and the names of persons required to be Present shall be as determined by the ENGINEER. CONTRACTOR shall comply with these attendance requirements and shall also require his SUBCONTRACTORS to comply.

**42. SAFETY**

The CONTRACTOR shall be solely and completely responsible for conditions of the jobsite, including safety of all persons (including employees) and Property during performance of the work. This requirement shall apply

continuously and not be limited to normal working hours. Safety Provisions shall conform to U.S. Department of Labor (OSHA), and all other applicable federal, state, county, and local laws, ordinances, codes, and regulations. Where any of these are in conflict, the more stringent requirement shall be followed. The CONTRACTOR's failure to thoroughly familiarize himself with the aforementioned safety Provisions shall not relieve him from compliance with the obligations and penalties set forth therein.

The CONTRACTOR shall develop and maintain for the duration of this Contract, a safety Program that will effectively incorporate and implement all required safety Provisions. The CONTRACTOR shall appoint an employee who is qualified and authorized to supervise and enforce compliance with the safety Program. The duty of the ENGINEER to conduct construction review of the work does not include review or approval of the adequacy of the CONTRACTOR's safety Program, safety supervisor, or any safety measures taken in, on, or near the construction site. The CONTRACTOR, as a part of his safety Program, shall maintain at his office or other well-known place at the jobsite, safety equipment applicable to the work as Prescribed by the aforementioned authorities, all articles necessary for giving first-aid to the injured, and shall establish the Procedure for the immediate removal to a hospital or a doctor's care of persons (including employees) who may be injured on the jobsite.

If death or serious injuries or serious damages are caused, the accident shall be reported immediately by telephone or messenger to both the ENGINEER and the OWNER. In addition, the CONTRACTOR must promptly report in writing to the ENGINEER all accidents whatsoever arising out of, or in connection with, the performance of the work whether on, or adjacent to, the site, giving full details and statements of witnesses.

If a claim is made by anyone against the CONTRACTOR or any SUBCONTRACTOR on account of any accident, the CONTRACTOR shall promptly report the facts in writing to the ENGINEER, giving full details of the claim.

#### **43. PROTECTION OF WORK AND PROPERTY**

The CONTRACTOR shall at all times safely guard and Protect from damage the OWNER's Property, adjacent Property, and his own work from injury or loss in connection with this Contract. All facilities required for Protection by federal, state, or municipal laws and regulations and local conditions must be provided and maintained.

The CONTRACTOR shall Protect his work and materials from damage due to the nature of the work, the elements, carelessness of other CONTRACTORS, or from any cause whatever until the completion and acceptance of the work. All loss or damages arising out of the nature of the work to be

done under these Contract Documents, or from any unforeseen obstruction or defects which may be encountered in the Prosecution of the work, or from the action of the elements, shall be sustained by the CONTRACTOR.

#### **44. RESPONSIBILITY OF CONTRACTOR TO ACT IN AN EMERGENCY**

In case of an emergency which threatens loss or injury of Property, and/or safety of life, the CONTRACTOR shall act, without previous instructions from the OWNER or ENGINEER, as the situation may warrant. The CONTRACTOR shall notify the ENGINEER thereof immediately thereafter. Any claim for compensation by the CONTRACTOR, together with substantiating documents in regard to expense, shall be submitted to the OWNER through the ENGINEER and the amount of compensation shall be determined by agreement.

#### **45. MATERIALS AND APPLIANCES**

Unless otherwise stipulated, the CONTRACTOR shall Provide and pay for all materials, labor, water, tools, equipment, heat, light, fuel, power, transportation, construction equipment and machinery, appliances, telephone, sanitary facilities, temporary facilities and other facilities and incidentals necessary for the execution and completion of the work.

Unless otherwise specified, all materials shall be new, and both workmanship and materials shall be of good quality. The CONTRACTOR shall, if required, furnish satisfactory evidence as to the kind and quality of materials.

In selecting and/or approving equipment for installation in the Project, the OWNER and ENGINEER assume no responsibility for injury or claims resulting from failure of the equipment to comply with applicable federal, state, and local safety codes or requirements, or the safety requirements of a recognized agency, or failure due to faulty design concepts, or defective workmanship and materials.

#### **46. CONTRACTORS' AND MANUFACTURERS' COMPLIANCE WITH STATE SAFETY, OSHA, AND OTHER CODE REQUIREMENTS**

The completed work shall include all necessary permanent safety devices, such as machinery guards and similar ordinary safety items required by the state and federal (OSHA) industrial authorities and applicable local and national codes. Further, any features of the work subject to such safety regulations shall be fabricated, furnished, and installed (including OWNER-furnished equipment) in compliance with these requirements. CONTRACTORS and manufacturers of

equipment shall be held responsible for compliance with the requirements included herein. CONTRACTORS shall notify all equipment suppliers and SUBCONTRACTORS of the Provisions of this Article.

#### **47. SUBSTITUTION OF MATERIALS**

Except for OWNER-selected equipment items, and items where no substitution is clearly specified, whenever any material, article, device, Product, fixture, form, type of construction, or Process is indicated or specified by patent or Proprietary name, by name of manufacturer, or by catalog number, such specifications shall be deemed to be used for the purpose of establishing a standard of quality and facilitating the description of the material or Process desired. This Procedure

is not to be construed as eliminating from competition other Products of equal or better quality by other manufacturers where fully suitable in design, and shall be deemed to be followed by the words "or equal". The CONTRACTOR may, in such cases, submit complete data to the ENGINEER for consideration of another material, type, or Process that shall be substantially equal in every respect to that so indicated or specified. Substitute materials shall not be used unless approved in writing. The ENGINEER will be the sole judge of the substituted article or material.

#### **48. TESTS, SAMPLES, AND OBSERVATIONS**

The CONTRACTOR shall furnish, without extra charge, the necessary test pieces and samples, including facilities and labor for obtaining the same, as requested by the ENGINEER. When required, the CONTRACTOR shall furnish certificates of tests of materials and equipment made at the point of manufacture by a recognized testing laboratory.

The OWNER, ENGINEER, and authorized government agents, and their representatives shall at all times be Provided safe access to the work wherever it is in Preparation or Progress, and the CONTRACTOR shall Provide facilities for such access and for observations, including maintenance of temporary and permanent access.

If the Specifications, laws, ordinances, or any public authority require any work, to be specially tested or approved, the CONTRACTOR shall give timely notice of its readiness for observations. If any work should be covered up without approval or consent of the ENGINEER, it shall, if required by the ENGINEER, be uncovered for examination at the CONTRACTOR's expense.

Reexamination of questioned work may be ordered by the ENGINEER, and, if so ordered, the work shall be uncovered by the CONTRACTOR. If such work is found to be in accordance with the Contract Documents, the OWNER will

pay the cost of uncovering, exposure, observation, inspection, testing and reconstruction. If such work is found to be not in accordance with the Contract Documents, the CONTRACTOR shall correct the defective work, and the cost of reexamination and correction of the defective work shall be paid by the CONTRACTOR.

#### **49. ROYALTIES AND PATENTS**

The CONTRACTOR shall pay all royalty and licenses fees, unless otherwise specified. The CONTRACTOR shall defend all suits or claims for infringement of any patent rights and shall save the OWNER and the ENGINEER harmless from any and all loss, including reasonable attorneys' fees, on account thereof.

#### **50. CONTRACTOR'S RIGHT TO TERMINATE CONTRACT**

If the work should be stopped under an order of any court or other public authority for a period of more than 3 months, through no act or fault of the CONTRACTOR, its SUBCONTRACTORS, or respective employees or if the ENGINEER should fail to make recommendation for payment to the OWNER or return payment request to CONTRACTOR for revision within 30 days after it is due, or if the OWNER should fail to pay the CONTRACTOR within 30 days after time specified in Article PARTIAL PAYMENTS, any sum recommended by the ENGINEER, then the CONTRACTOR may, upon 15 days' written notice to the OWNER and the ENGINEER, stop work or terminate this Contract and recover from the OWNER payment for all acceptable work performed and reasonable termination expenses, unless said default has been remedied.

#### **51. CORRECTION OF DEFECTIVE WORK DURING WARRANTY PERIOD**

The CONTRACTOR hereby agrees to make, at his own expense, all repairs or replacements necessitated by defects in materials or workmanship, Provided under terms of this Contract, and pay for any damage to other works resulting from such defects, which become evident within 2 years after the date of final acceptance of the work or within 2 years after the date of substantial completion established by the ENGINEER for specified items of equipment, or within such longer period as may be Prescribed by law or by the terms of any applicable special guarantee required by the Contract Documents. Un-remedied defects identified for correction during the warranty period but remaining after its expiration shall be considered as part of the obligations of the warranty. Defects in material, workmanship, or equipment which are remedied as a result of obligations of the warranty shall subject the remedied portion of the work to an extended

warranty period of 2 years after the defect has been remedied.

The CONTRACTOR further assumes responsibility for a similar guarantee for all work and materials provided by SUBCONTRACTORS or manufacturers of packaged equipment components. The effective date for the start of the guarantee or warranty period for equipment qualifying as substantially complete is defined in Article SUBSTANTIAL COMPLETION, AND Article SUBSTANTIAL COMPLETION DATE, in these General Conditions.

The CONTRACTOR also agrees to hold the OWNER and the ENGINEER harmless from liability of any kind arising from damage due to said defects. The CONTRACTOR shall make all repairs and replacements promptly upon receipt of written order for same from the OWNER. If the CONTRACTOR fails to make the repairs and replacements promptly, or in an emergency where delay would cause serious risk, or loss, or damage, the OWNER may have the defective work corrected or the rejected work removed and replaced, and the CONTRACTOR and his Surety shall be liable for the cost thereof.

#### **PROGRESS OF THE WORK**

##### **52. BEGINNING OF THE WORK**

Following execution of the Contract, the CONTRACTOR shall meet with the OWNER and ENGINEER relative to his arrangements for prosecuting the work.

##### **53. SCHEDULES AND PROGRESS REPORTS**

Prior to starting the construction, the CONTRACTOR shall Prepare and submit to the ENGINEER, a Progress schedule showing the dates on which each part or division of the work is expected to be started and finished, and a Preliminary schedule for submittals. The Progress schedule for submittals shall be brought up to date and submitted to the ENGINEER at the end of each month or at such other times the ENGINEER may request.

The CONTRACTOR shall forward to the ENGINEER, at the end of each month, an itemized report of the delivery status of major and critical items of purchased equipment and material, including shop drawings and the status of shop and field fabricated work. These Progress reports shall indicate the date of the purchase order, the current percentage of completion, estimated delivery, and cause of delay, if any.

If the completion of any part of the work or the delivery of materials is behind the submitted Progress schedule, the CONTRACTOR shall submit in writing a plan acceptable to the OWNER and ENGINEER for bringing the work up to

schedule.

The OWNER shall have the right to withhold Progress payments for the work if the CONTRACTOR fails to update and submit the Progress schedule and reports as specified.

##### **54. PROSECUTION OF THE WORK**

It is expressly understood and agreed that the time of beginning, rate of Progress, and time of completion of the work are the essence of this Contract. The work shall be prosecuted at such time, and in or on such part or parts of the Project as may be required, to complete the Project as contemplated in the Contract Documents and the Progress schedule.

If the CONTRACTOR desires to carry on work at night or outside the regular hours, he shall give timely notice to the ENGINEER to allow satisfactory arrangements to be made for observing the work in Progress.

##### **55. OWNER'S RIGHT TO RETAIN IMPERFECT WORK**

If any part or portion of the work completed under this Contract shall Prove defective and not in accordance with the Drawings and Specifications, and if the imperfection in the same shall not be of sufficient magnitude or importance as to make the work dangerous or unsuitable, or if the removal of such work will create conditions which are dangerous or undesirable, the OWNER shall have the right and authority to retain such work but will make such deductions in the final payment therefore as may be just and reasonable.

##### **56. OWNER'S RIGHT TO DO WORK**

Should the CONTRACTOR neglect to Prosecute the work in conformance with the Contract Documents or neglect or refuse at his own cost to remove and replace work rejected by the ENGINEER, then the OWNER may notify the Surety of the condition, and after 10 days' written notice to the CONTRACTOR and the Surety, or without notice if an emergency or danger to the work or public exists, and without Prejudice to any other right which the OWNER may have under Contract, or otherwise, take over that portion of the work which has been improperly or non timely executed, and make good the deficiencies and deduct the cost thereof from the payments then or thereafter due the CONTRACTOR.

##### **57. OWNER'S RIGHT TO TRANSFER EMPLOYMENT**

If the CONTRACTOR should abandon the work or if he



should persistently or repeatedly refuse or should fail to make prompt payment to SUBCONTRACTORS for material or labor, or to persistently disregard laws, ordinances, or to prosecute the work in conformance with the Contract Documents, or otherwise be guilty of a substantial violation of any Provision of the Contract or any laws or ordinance, then the OWNER may, without Prejudice to any other right or remedy, and after giving the CONTRACTOR and Surety 10 days' written notice, transfer the employment for said work from the CONTRACTOR to the Surety. Upon receipt of such notice, such Surety shall enter upon the Premises and take possession of all materials, tools, and appliances thereon for the purpose of completing the work included under this contract and employ by Contract or otherwise, any qualified person or persons to finish the work and Provide the materials therefore, in accordance with the Contract Documents, without termination of the continuing full force and effect of this contract. In case of such transfer of employment to such Surety, the Surety shall be paid in its own name on estimates according to the terms hereof without any right of the CONTRACTOR to make any claim for the same or any part thereof.

If, after the furnishing of said written notice to the Surety, the CONTRACTOR and the Surety still fail to make reasonable Progress on the performance of the work, the OWNER may terminate the employment of the CONTRACTOR and take possession of the Premises and of all materials, tools, and appliances thereon and finish the work by whatever method he may deem expedient and charge the cost thereof to the CONTRACTOR and the Surety. In such case, the CONTRACTOR shall not be entitled to receive any further payment until the work is finished. If the expense of completing the Contract, including compensation for additional managerial and administrative services, shall exceed such unpaid balance, the CONTRACTOR and the Surety shall pay the difference to the OWNER.

#### **58. DELAYS AND EXTENSION OF TIME**

If the CONTRACTOR is delayed in the Progress of the work by any act or neglect of the OWNER or the ENGINEER, or by any separate CONTRACTOR employed by the OWNER, or by strikes, lockouts, fire, adverse weather conditions not reasonably anticipated, or acts of Nature, and if the CONTRACTOR, within 48 hours of the start of the occurrence, gives written notice to the OWNER of the cause of the potential delay and estimate of the possible time extension involved, and within 10 days after the cause of the delay has been remedied, the CONTRACTOR gives written notice to the OWNER of any actual time extension requested as a result of the aforementioned occurrence, then the Contract time may be extended by change order for such reasonable time as the ENGINEER determines. It is agreed that no claim

shall be made or allowed for any damages, loss, or expense which may arise out of any delay caused by the above referenced acts or occurrences other than claims for the appropriate extension of time. No extension of time will be granted to the CONTRACTOR for delays occurring to parts of the work that have no measurable impact on the completion of the total work under this Contract. No extension of time will be considered for weather conditions reasonably anticipated for the area in which the work is being performed. Reasonably anticipated weather conditions will be based on official records of monthly Precipitation and other historical data. Adverse weather conditions, if determined to be of a severity that would impact Progress of the work, may be considered as cause for an extension of Contract completion time.

Delays in delivery of equipment or material purchased by the CONTRACTOR or his SUBCONTRACTORS, including OWNER-selected equipment shall not be considered as a just cause for delay, unless the OWNER determines that for good cause the delay is beyond the control of the CONTRACTOR. The CONTRACTOR shall be fully responsible for the timely ordering, scheduling, complete the work is the per-diem rate, as stipulated in the Proposal. The said amount is hereby agreed upon as a reasonable estimate of the costs, which may be accrued by the OWNER after the expiration of the time of completion. It is expressly understood and agreed that this amount is not to be considered in the nature of a penalty, but as liquidated damages which have accrued against the CONTRACTOR. The OWNER shall have the right to deduct such damages from any amount due, or that may become due the CONTRACTOR, or the amount of such damages shall be due and collectible from the CONTRACTOR or Surety.

#### **59. DIFFERING SITE CONDITIONS**

The CONTRACTOR shall promptly, and before the conditions are disturbed, give a written notice to the OWNER and ENGINEER of:

- A. subsurface or latent physical conditions at the site which differ materially from those indicated in this contract,
- B. unknown physical conditions at the site, of an unusual nature, which differ materially from those ordinarily encountered and generally recognized as inherent in work of the character provided for in the Contract.

The ENGINEER will investigate the site conditions promptly after receiving the notice. If the conditions do materially so differ and cause an increase or decrease in the CONTRACTOR's cost of, or the time required for, performing any part of the work under this Contract, whether

or not changed as a result of the conditions, and equitable adjustment shall be made under this Article and the Contract modified in writing accordingly.

No request by the CONTRACTOR for an equitable adjustment to the Contract under this Article will be allowed, unless the CONTRACTOR has given the written notice required; Provided that the time prescribed above for giving written notice may be extended by the OWNER.

No request by the CONTRACTOR for an equitable adjustment to the Contract for differing site conditions will be allowed if made after final payment under this Contract.

#### **60. LIQUIDATED DAMAGES**

Should the CONTRACTOR fail to complete the work, or any part thereof, in the time agreed upon in the Contract or within such extra time as may have been allowed for delays by extensions granted as Provided in the Contract, the CONTRACTOR shall reimburse the OWNER for the additional expense and damage for each calendar day, Sundays and legal holidays included, that the Contract remains uncompleted after the Contract completion date. It is agreed that the amount of such additional expense and damage incurred by reason of failure to complete the work is the per diem rate, as stipulated in the Proposal. The said amount is hereby agreed upon as a reasonable estimate of the costs which may be accrued by the OWNER after the expiration of the time of completion. It is expressly understood and agreed that this amount is not to be considered in the nature of a penalty, but as liquidated damages which have accrued against the CONTRACTOR. The OWNER shall have the right to deduct such damages from any amount due, or that may become due the CONTRACTOR, or the amount of such damages shall be due and collectible from the CONTRACTOR or Surety.

#### **61. OTHER CONTRACTS**

The OWNER reserves the right to let other Contracts in connection with the work. The CONTRACTOR shall afford other CONTRACTORS reasonable opportunity for the introduction and storage of their materials and the execution of their work and shall properly connect and coordinate his work with theirs.

If any part of the work under this Contract depends for Proper execution or results upon the work of any other CONTRACTOR, utility service company or OWNER, the CONTRACTOR shall inspect and Promptly report to the ENGINEER in writing any patent or apparent defects to deficiencies in such work that render it unsuitable for such Proper execution and results. The CONTRACTOR's failure to so report shall constitute and acceptance of the work by

others as being fit and Proper for integration with work under this Contract, except for latent or non apparent defects and deficiencies in the work.

#### **62. USE OF PREMISES**

The CONTRACTOR shall confine his equipment, the storage of materials and the operation of his workers to limits shown on the Drawings or indicated by law, ordinances, permits, or directions of the ENGINEER, and shall not unreasonably encumber the Premises with his materials. The CONTRACTOR shall provide, at his own expense, the necessary rights-of-way and access to the work, which may be required outside the limits of the OWNER's Property and shall furnish the ENGINEER copies of permits and agreements for use of the Property outside that provided by the OWNER.

The CONTRACTOR shall not load nor permit any part of the structure to be loaded in any manner that will endanger the structure, nor shall CONTRACTOR subject any part of the work or adjacent Property to stresses or Pressures that will endanger it.

#### **63. SUBSTANTIAL COMPLETION DATE**

The ENGINEER may issue a written notice of substantial completion for the purpose of establishing the starting date for specific equipment guarantees, and to establish the date that the OWNER will assume the responsibility for the cost of operating such equipment. Said notice shall not be considered as final acceptance of any portion of the work or relieve the CONTRACTOR from completing the remaining work within the specified time and in full compliance with the Contract Documents. See SUBSTANTIAL COMPLETION under DEFINITIONS of these General Conditions.

#### **64. PERFORMANCE TESTING**

Operating equipment and systems shall be performance tested in the Presence of the ENGINEER to demonstrate compliance with the specified requirements. Performance testing shall be conducted under the specified design operating conditions or under such simulated operating conditions as recommended or approved by the ENGINEER. Schedule such testing with the ENGINEER at least one week in advance of the planned date for testing.

#### **65. OWNER'S USE OF PORTIONS OF THE WORK**

Following issuance of the written notice of Substantial Completion, the OWNER may initiate operation of the facility. Such use shall not be considered as final acceptance

of any portion of the work, nor shall such use be considered as cause for an extension of the Contract completion time, unless authorized by a Change Order issued by the OWNER.

**66. CUTTING AND PATCHING**

The CONTRACTOR shall do all cutting, fitting, or patching of his work that may be required to make its several parts come together Properly and fit it to receive or be received by work of other CONTRACTORS shown upon or reasonably implied by the Drawings.

**67. CLEANING UP**

The CONTRACTOR shall, at all times, keep Property on which work is in Progress and the adjacent Property free from accumulations of waste material or rubbish caused by employees or by the work. Upon completion of the construction, the CONTRACTOR shall remove all temporary structures, rubbish, and waste materials resulting from his operations.

**PAYMENT**

**68. PAYMENT FOR CHANGE ORDERS**

The OWNER's request for quotations on alterations to the work shall not be considered authorization to proceed with the work expediting, delivery, and installation of all equipment and materials. Within a reasonable period after the CONTRACTOR submits to the OWNER a written request for an extension of time, the ENGINEER will Present his written opinion to the OWNER as to whether an extension of time is justified, and, if so, his recommendation as to the number of days for time extension. The OWNER will make the final decision on all requests for extension of time.

Prior to the issuance of a formal Change Order, nor shall such request justify any delay in existing work. Quotations for alterations to the work shall include substantiating documentation with an itemized breakdown of CONTRACTOR and SUBCONTRACTOR costs, including labor, material, rentals, approved services, overhead, and profit. OWNER may require detailed cost data in order to substantiate the reasonableness of the proposed costs.

Any compensation paid in conjunction with the terms of a Change Order shall comprise total compensation due the CONTRACTOR for the work or alteration defined in the Change Order. By signing the Change Order, the CONTRACTOR acknowledges that the stipulated compensation includes payment for the work or alteration plus all payment for the interruption of schedules, extended overhead, delay, or any other impact claim or ripple effect, and

by such signing specifically waives any reservation or claim for additional compensation in respect to the subject Change Order.

At the OWNER's option, payment or credit for any alterations covered by a Change Order shall be determined by one or a combination of the methods set forth in A, B, or C below, as applicable:

**A. UNIT PRICES**

Those unit Prices stipulated in the Proposal shall be utilized where they are applicable. In the event the Change Order results in a change in the original quantity that is materially and significantly different from the original bid quantity, a new unit Price shall be negotiated upon demand of either party. Unit Prices for new items included in the Change Order shall be negotiated and mutually agreed upon.

**B. LUMP SUM**

A total lump sum for the work negotiated and mutually acceptable to the CONTRACTOR and the OWNER. Lump sum quotations for modifications to the work shall include substantiating documentation with an itemized breakdown of CONTRACTOR and SUBCONTRACTOR costs, including labor, material, rentals, approved services, overhead, and Profit, all calculated as specified under "C" below.

**C. COST REIMBURSEMENT WORK**

The term "cost reimbursement" shall be understood to mean that payment for the work will be made on a time and expense basis, that is, on an accounting of the CONTRACTOR's forces, materials, equipment, and other items of cost as required and used to do the work.

If the method of payment cannot be agreed upon Prior to the beginning of the work, and the OWNER directs by written Change Order that the work be done on a cost reimbursement basis, then the CONTRACTOR shall furnish labor, and furnish and install equipment and materials necessary to complete the work in a satisfactory manner and within a reasonable period of time. For the work performed, payment will be made for the documented actual cost of the following:

1. Labor including foremen for those hours they are assigned and participating in the cost reimbursement work (actual payroll cost, including wages, fringe benefits as established by negotiated labor agreements, labor insurance, and labor taxes as established by law). No other fixed labor burdens will be considered, unless approved in writing by the OWNER.
2. Material delivered and used on the designated work,

- including sales tax, if paid by the CONTRACTOR or his SUBCONTRACTOR.
3. Rental or equivalent rental cost of equipment, including necessary transportation for items having a value in excess of \$100. Rental or equivalent rental cost will be allowed for only those days or hours during which the equipment is in actual use. Rental and transportation allowances shall not exceed the current rental rates prevailing in the locality. The rentals allowed for equipment will, in all cases, be understood to cover all fuel, supplies, repairs, and renewals, and no further allowances will be made for those items, unless specific agreement to that effect is made.
  4. Additional bond, as required and approved by the OWNER.
  5. Additional insurance (other than labor insurance) as required and approved by the OWNER.

In addition to items 1 through 5 above, an added fixed fee for general overhead and Profit shall be negotiated and allowed for the CONTRACTOR (or approved SUBCONTRACTOR) actually executing the Cost Reimbursement work.

An additional fixed fee shall be negotiated and allowed the CONTRACTOR for the administrative handling of portions of the work that are executed by an approved SUBCONTRACTOR. No additional fixed fee will be allowed for the administrative handling of work executed by a SUBCONTRACTOR of a SUBCONTRACTOR, unless by written permission from the OWNER.

The added fixed fees shall be considered to be full compensation, covering the cost of general supervision, overhead, Profit, and any other general expense. The CONTRACTOR's records shall make clear distinction between the direct costs of work paid for on a cost reimbursement basis and the costs of other work. The CONTRACTOR shall furnish the ENGINEER report sheets in duplicate of each day's cost reimbursement work no later than the working day following the performance of said work. The daily report sheets shall itemize the materials used, and shall cover the direct cost of labor and the charges for equipment rental, whether furnished by the CONTRACTOR, SUBCONTRACTOR or other forces. The daily report sheets shall provide names or identifications and classifications of workers, the hourly rate of pay and hours worked, and also the size, type, and identification number of equipment and hours operated.

Material charges shall be substantiated by valid copies of vendors' invoices. Such invoices shall be submitted with the daily report sheets, or, if not available, they shall be submitted with subsequent daily report sheets. Said daily report sheets

shall be signed by the CONTRACTOR or his authorized agent.

The OWNER reserves the right to furnish such materials and equipment as he deems expedient and the CONTRACTOR shall have no claim for profit or added fees on the cost of such materials and equipment. To receive partial payments and final payment for cost reimbursement work, the CONTRACTOR shall submit to the ENGINEER, detailed and complete documented verification of the CONTRACTOR's and any of his SUBCONTRACTORS' actual costs involved in the cost reimbursement work. Such costs shall be submitted within 30 days after said work has been performed.

## **69. PARTIAL PAYMENTS**

### **A. GENERAL**

Nothing in this Article shall be construed to affect the right, hereby reserved, to reject the whole or any part of the aforesaid work, should such work be later found not to comply with the Provisions of the Contract Documents. All estimated quantities of work for which partial payments have been made are subject to review and correction on the final estimate. Payment by the OWNER and acceptance by the CONTRACTOR of partial payments based on periodic estimates of quantities of work performed shall not, in any way, constitute acceptance of the estimated quantities used as a basis for computing the amounts of the partial payments.

### **B. ESTIMATE**

At least 30 days before each Progress payment falls due, as specified in the Supplementary Conditions, the CONTRACTOR shall submit to the ENGINEER a detailed estimate of the amount earned during the Preceding month for the separate portions of the work, and request payment. As used in this Article, the words "amount earned" means the value, on the date of the estimate for partial payment, of the work completed in accordance with the Contract Documents, and the value of approved materials delivered to the Project site suitable stored and Protected Prior to incorporation into the work.

ENGINEER will, within 7 days after receipt of each request for payment, either indicate in writing a recommendation of payment and present the request to OWNER, or return the request to CONTRACTOR indicating in writing ENGINEER's reasons for refusing to recommend payment. In the latter case, CONTRACTOR may, within 7 days, make the necessary corrections and resubmit the request.

ENGINEER may refuse to recommend the whole or any part of any payment if, in his opinion, it would be incorrect to

make such representations to OWNER. ENGINEER may also refuse to recommend any such payment, or, because of subsequently discovered evidence or the results of subsequent inspections or tests, nullify any such payment previously recommended to such an extent as may be necessary in ENGINEER's opinion to protect the OWNER from loss because:

1. The work is defective, or completed work has been damaged requiring correction or replacement;
2. Written claims have been made against OWNER or Liens have been filed in connection with the work;
3. The Contract Price has been reduced because of Change Orders;
4. OWNER has been required to correct defective work or complete the work in accordance with Article OWNER'S RIGHT TO DO WORK;
5. Of CONTRACTOR's unsatisfactory Prosecution of the work in accordance with the Contract Documents; or
6. CONTRACTOR's failure to make payment to SUBCONTRACTORS or for labor, materials, or equipment.

**C. DEDUCTION FROM ESTIMATE**

Unless modified in the Supplementary Conditions, deductions from the estimate will be as described below:

1. The OWNER will deduct from the estimate, and retain as part security, 10 percent of the amount earned for work satisfactorily completed. A deduction and retainage of 10 percent will be made on the estimated amount earned for approved items of material delivered to and properly stored at the jobsite but not incorporated into the work. When the work is 50 percent complete, the OWNER may reduce the retainage to 5 percent of the dollar value of all work satisfactorily completed to date provided the CONTRACTOR is making satisfactory progress and there is no specific cause for a greater retainage. The OWNER may reinstate the retainage up to 10 percent if the OWNER determines, at his discretion, that the CONTRACTOR is not making satisfactory progress or where there is other specific cause for such withholding.

**D. QUALIFICATION FOR PARTIAL PAYMENT FOR MATERIALS DELIVERED**

Unless modified in the Supplementary Conditions, qualification for partial payment for materials delivered but not yet incorporated into the work shall be as described below:

1. Materials, as used herein, shall be considered to be those items which are fabricated and manufactured material and equipment. No consideration shall be given to individual purchases of less than \$200 for any one item.
2. To receive partial payment for materials delivered to the site, but not incorporated in the work, it shall be necessary for the CONTRACTOR to include a list of such materials on the Partial Payment Request. At his sole discretion, the ENGINEER may approve items for which partial payment is to be made. Partial payment shall be based on the CONTRACTOR's actual cost for the materials as evidenced by invoices from the supplier. Proper storage and Protection shall be provided by the CONTRACTOR, and as approved by the ENGINEER. Final payment shall be made only for materials actually incorporated in the work and, upon acceptance of the work, all materials remaining for which advance payments had been made shall revert to the CONTRACTOR, unless otherwise agreed, and partial payments made for these items shall be deducted from the final payment for the work.
3. CONTRACTOR warrants and guarantees that title to all work, materials, and equipment covered by any Application for Payment, whether incorporated in the Project or not, will pass to OWNER at the time of payment free and clear of all liens, claims, security interests, and encumbrances.
4. If requested by the ENGINEER, the CONTRACTOR shall provide, with subsequent pay requests, invoices receipted by the supplier showing payment in full has been made.

**E. PAYMENT**

After deducting the retainage and the amount of all previous partial payments made to the CONTRACTOR from the amount earned, the amount due will be made payable to the CONTRACTOR. Recommendations for payment received by the OWNER less than 9 days Prior to the scheduled day for payment will not be Processed or paid until the following month.

**70. CLAIMS FOR EXTRA WORK**

In any case where the CONTRACTOR deems additional time or compensation will become due him under this Contract for circumstances other than those defined in Article DELAYS AND EXTENSION OF TIME, the CONTRACTOR shall notify the ENGINEER, in writing, of his intention to make claim for such time or compensation before he begins the work on which he bases the claim, in order that such matters may be settled, if possible, or other appropriate action taken. The notice of claim shall be in duplicate, in writing, and shall state the circumstances and the reasons for the claim, but need not state the amount. If such notification is not given or if the ENGINEER is not afforded proper facilities by the CONTRACTOR for keeping strict account of actual cost, then the CONTRACTOR hereby agrees to waive the claim for such additional time or compensation. Such notice by the CONTRACTOR, and fact that the ENGINEER has kept account of the cost as aforesaid, shall not in any way be construed as proving the validity of the claim.

No extension of time will be granted to the CONTRACTOR for delays resulting from extra work that have no measurable impact on the completion of the total work under this Contract. Claims for additional time or compensation shall be made in itemized detail and submitted, in writing, to the OWNER and ENGINEER within 10 days following completion of that portion of the work for which the CONTRACTOR bases his claim. Failure to make the claim for additional compensation in the manner and within the time specified above shall constitute waiver of that claim. In case the claim is found to be just, it shall be allowed and paid for as provided in Article PAYMENT FOR CHANGE ORDERS.

#### **71. RELEASE OF LIENS OR CLAIMS**

The CONTRACTOR shall indemnify and hold harmless the OWNER from all claims for labor and materials furnished under this Contract. Prior to the final payment, the CONTRACTOR shall furnish to the OWNER, as part of his final payment request, a certification that all of the CONTRACTOR's obligations on the project have been satisfied and that all monetary claims and indebtedness have been paid. The CONTRACTOR shall furnish complete and legal effective releases or waivers, satisfactory to the OWNER, of all liens arising out of or filed in connection with the work.

#### **72. FINAL PAYMENT**

Upon completion of all the work under this Contract, the CONTRACTOR shall notify the ENGINEER, in writing, that he has completed his part of the Contract and shall request final payment. Upon receipt of such notice the ENGINEER will inspect and, if acceptable, submit to the OWNER his recommendation as to acceptance of the completed work and as to the final estimate of the amount due the CONTRACTOR. Upon approval of this final estimate by the OWNER and compliance by the CONTRACTOR with Provisions in Article **RELEASE OF LIENS OR CLAIMS**, and other Provisions as may be applicable, the OWNER shall pay to the CONTRACTOR all monies due him under the Provisions of these Contract Documents.

#### **73. NO WAIVER OF RIGHTS**

Neither the inspection by the OWNER, through the ENGINEER or any of his employees, nor any order by the OWNER for payment of money, nor any payment for, or acceptance of, the whole or any part of the work by the OWNER or ENGINEER, nor any extension of time, nor any possession taken by the OWNER or its employees, shall operate as a waiver of any Provision of this Contract, or any power herein reserved to the OWNER, or any right to damages herein Provided, nor shall any waiver of any breach in this Contract be held to be a waiver of any other or subsequent breach. Acceptance or final payment shall not be final and conclusive with regards to latent defects, fraud, or such gross mistakes as may amount to fraud, or as regards the OWNER's rights under the warranty.

#### **74. ACCEPTANCE OF FINAL PAYMENT CONSTITUTES RELEASE**

The acceptance by the CONTRACTOR of the final payment shall release the OWNER and the ENGINEER, as representatives of the OWNER, from all claims and all liability to the CONTRACTOR for all things done or furnished in connection with the work, and every act of the OWNER and others relating to or arising out of the work except claims Previously made in writing and still unsettled. No payment, however, final or otherwise, shall operate to release the CONTRACTOR or his Sureties from obligations under this Contract and the Performance Bond, Payment Bond, and other bonds and warranties, as herein provided.

## SUPPLEMENTARY CONDITIONS

The General Conditions are hereby revised as follows:

### ARTICLE 9 "ENGINEER"

Add the following:

Wherever in these Documents the word "Engineer" appears, it shall be understood to mean the ENGINEER OF RECORD.

### ARTICLE 34 "INSURANCE & LIABILITY"

Before commencing work as specified in the contract Contractor shall obtain at its own cost and expense the following insurance in insurance companies authorized in the State of Florida, with an A.M. Best rating of A-:VI or higher and shall provide evidence of such insurance to the City. The policies or certificates shall provide thirty (30) days prior to cancellation notices of same shall be given to the City by registered mail, return receipt requested, for all of the required insurance policies stated below. All notices shall name the Contractor and identify the agreement or contract number. The City of Key West, all Departments, Agencies, Boards and Commissions, its officers, agents, servants and employees are to be added as "Additional Insured" as respects liability arising out of activities performed by or on behalf of the Contractor.

Contractor shall maintain limits no less than those stated below:

CONTRACTOR is to secure, pay for, and file with the City of Key West, prior to commencing any work under the Contract, all certificates for workers' compensation, public liability, and property damage liability insurance, and such other insurance coverages as may be required by specifications and addenda thereto, in at least the following minimum amounts with specification amounts to prevail if greater than minimum amounts indicated. Notwithstanding any other provision of the Contract, the CONTRACTOR shall provide the minimum limits of liability insurance coverage as follows:

Auto Liability	\$1,000,000	Combined Single Limit
General Liability	\$2,000,000	Aggregate (Per Project)
	\$2,000,000	Products Aggregate
	\$1,000,000	Any One Occurrence
	\$1,000,000	Personal Injury
	\$ 300,000	Fire Damage/Legal
<b>Additional Umbrella Liability</b>	\$0,000,000	Occurrence / Aggregate

CONTRACTOR shall furnish an original Certificate of Insurance indicating, and such policy providing coverage to, City of Key West named as an additional insured on a PRIMARY and NON CONTRIBUTORY basis utilizing an ISO standard endorsement at least as broad as CG 2010 (11/85) or its equivalent, (combination of CG 20 10 07 04 and CG 20 37 07 04, providing coverage for completed operations, is acceptable) including a waiver of subrogation clause in favor of City of Key West on all policies. CONTRACTOR will maintain the General Liability and Umbrella Liability insurance coverages summarized above with coverage continuing in full force including the additional insured endorsement until at least 3 years beyond completion and delivery of the work contracted herein.

Notwithstanding any other provision of the Contract, the CONTRACTOR shall maintain complete workers' compensation coverage for each and every employee, principal, officer, representative, or agent of the CONTRACTOR who is performing any labor, services, or material under the Contract. Further, CONTRACTOR shall additionally maintain the following minimum limits of coverage:

Bodily Injury Each Accident	\$1,000,000
Bodily Injury by Disease Each Employee	\$1,000,000
Bodily Injury by Disease Policy Limit	\$1,000,000

If the work is being done on or near a navigable waterway, CONTRACTOR's workers compensation policy shall be endorsed to provide USL&H Act (WC 00 01 06 A) and Jones Act (WC 00 02 01 A) coverage if specified by the City of Key West. CONTRACTOR shall provide the City of Key West with a Certificate of Insurance verifying compliance with the workman's compensation coverage as set forth herein and shall provide as often as required by the City of Key West such certification which shall also show the insurance company, policy number, effective and expiration date, and the limits of workman's compensation coverage under each policy.

CONTRACTOR's insurance policies shall be endorsed to give 30 days written notice to the City of Key West in the event of cancellation or material change, using form CG 02 24, or its equivalent.

Certificates of Insurance submitted to the City of Key West will not be accepted without copies of the endorsements being requested. This includes additional insured endorsements, cancellation/material change notice endorsements, and waivers of subrogation. Copies of USL&H Act and Jones Act endorsements will also be required if necessary. PLEASE ADVISE YOUR INSURANCE AGENT ACCORDINGLY.

CONTRACTOR will comply with any and all safety regulations required by any agency or regulatory body including but not limited to OSHA. CONTRACTOR will notify City of Key West immediately by telephone at (305) 809-3867 any accident or injury to anyone that occurs on the jobsite and is related to any of the work being performed by the CONTRACTOR.



Add the following Article:

G. SURETY AND INSURER QUALIFICATIONS

All bonds, insurance contracts, and certificates of insurance shall be either executed by or countersigned by a licensed resident agent of the Surety or insurance company, having his place of business in the State of Florida, and in all ways complying with the insurance laws of the State of Florida. Further, the said Surety or Insurance Company shall be duly licensed and qualified to do business in the State of Florida. If requested, Contractor shall Provide Proof of Florida Licensure for all insurance companies. The City of Key West shall be named as Additional Insured on the insurance certificates

H. EQUAL BENEFITS FOR DOMESTIC PARTNERS

**Sec. 2-799. Requirements for City Contractors to Provide Equal Benefits for Domestic Partners.**

(a) Definitions. For purposes of this section only, the following definitions shall apply:

(1) **Benefits** means the following plan, program or policy provided or offered by a contractor to its employees as part of the employer's total compensation package: sick leave, bereavement leave, family medical leave, and health benefits.

(2) **Bid** shall mean a competitive bid procedure established by the city through the issuance of an invitation to bid, request for proposals, request for qualifications, or request for letters of interest.

(3) **Cash equivalent** means the amount of money paid to an employee with a domestic partner in lieu of providing benefits to the employee's domestic partner. The cash equivalent is equal to the employer's direct expense of providing benefits to an employee for his or her spouse.

The cash equivalent of the following benefits apply:

a. For bereavement leave, cash payment for the number of days that would be allowed as paid time off for the death of a spouse. Cash payment would be in the form of the wages of the domestic partner employee for the number of days allowed.

b. For health benefits, the cost to the contractor of the contractor's share of the single monthly premiums that are being paid for the domestic partner employee, to be paid on a regular basis while the domestic partner employee maintains such insurance in force for himself or herself.

c. For family medical leave, cash payment for the number of days that would be allowed as time off for an employee to care for a spouse who has a serious health

condition. Cash payment would be in the form of the wages of the domestic partner employee for the number of days allowed.

(4) **Contract** means any written agreement, purchase order, standing order or similar instrument entered into pursuant to the award of a bid whereby the city is committed to expend or does expend funds in return for work, labor, professional services, consulting services, supplies, equipment, materials, construction, construction related services or any combination of the foregoing.

(5) **Contractor** means any person or persons, sole proprietorship, partnership, joint venture, corporation, or other form of doing business, that is awarded a bid and enters into a covered contract with the city, and which maintains five (5) or more full-time employees.

(6) **Covered contract** means a contract between the city and a contractor awarded subsequent to the date when this section becomes effective valued at over twenty thousand dollars (\$20,000).

(7) **Domestic partner** shall mean any two adults of the same or different sex, who have registered as domestic partners with a governmental body pursuant to state or local law authorizing such registration, or with an internal registry maintained by the employer of at least one of the domestic partners. A contractor may institute an internal registry to allow for the provision of equal benefits to employees with domestic partner who do not register their partnerships pursuant to a governmental body authorizing such registration, or who are located in a jurisdiction where no such governmental domestic partnership registry exists. A contractor that institutes such registry shall not impose criteria for registration that are more stringent than those required for domestic partnership registration by the City of Key West pursuant to Chapter 38, Article V of the Key West Code of Ordinances.

(8) **Equal benefits** mean the equality of benefits between employees with spouses and employees with domestic partners, and/or between spouses of employees and domestic partners of employees.

(b) Equal benefits requirements.

(1) Except where otherwise exempt or prohibited by law, a Contractor awarded a covered contract pursuant to a bid process shall provide benefits to domestic partners of its employees on the same basis as it provides benefits to employees' spouses.

(2) All bid requests for covered contracts which are issued on or after the effective date of this section shall include the requirement to provide equal benefits in the procurement specifications in accordance with this section.

(3) The city shall not enter into any covered contract unless the contractor certifies that such contractor does not discriminate in the provision of benefits between employees with domestic partners and employees with spouses and/or between the domestic partners and spouses of such employees.

(4) Such certification shall be in writing and shall be signed by an authorized officer of the contractor and delivered, along with a description of the contractor's employee benefits plan, to the city's procurement director prior to entering into such covered contract.

(5) The city manager or his/her designee shall reject a contractor's certification of compliance if he/she determines that such contractor discriminates in the provision of benefits or if the city manager or designee determines that the certification was created, or is being used for the purpose of evading the requirements of this section.

(6) The contractor shall provide the city manager or his/her designee, access to its records for the purpose of audits and/or investigations to ascertain compliance with the provisions of this section, and upon request shall provide evidence that the contractor is in compliance with the provisions of this section upon each new bid, contract renewal, or when the city manager has received a complaint or has reason to believe the contractor may not be in compliance with the provisions of this section. This shall include but not be limited to providing the city manager or his/her designee with certified copies of all of the contractor's records pertaining to its benefits policies and its employment policies and practices.

(7) The contractor may not set up or use its contracting entity for the purpose of evading the requirements imposed by this section.

(c) Mandatory contract provisions pertaining to equal benefits. Unless otherwise exempt, every covered contract shall contain language that obligates the contractor to comply with the applicable provisions of this section. The language shall include provisions for the following:

(1) During the performance of the covered contract, the contractor certifies and represents that it will comply with this section.

(2) The failure of the contractor to comply with this section will be deemed to be a material breach of the covered contract.

(3) If the contractor fails to comply with this section, the city may terminate the covered contract and all monies due or to become due under the covered contract may be retained by the city. The city may also pursue any and all other remedies at law or in equity for any breach.

(4) If the city manager or his designee determines that a contractor has set up or used its contracting entity for the purpose of evading the requirements of this section, the city may terminate the covered contract.

(d) Enforcement. If the contractor fails to comply with the provisions of this section:

(1) The failure to comply may be deemed to be a material breach of the covered contract; or

(2) The city may terminate the covered contract; or

(3) Monies due or to become due under the covered contract may be retained by the city until compliance is achieved; or

(4) The city may also pursue any and all other remedies at law or in equity for any breach;

(5) Failure to comply with this section may also subject contractor to the procedures set forth in Division 5 of this article, entitled "Debarment of contractors from city work."

(e) Exceptions and waivers.

The provisions of this section shall not apply where:

(1) The contractor does not provide benefits to employees' spouses.

(2) The contractor is a religious organization, association, society or any non-profit charitable or educational institution or organization operated, supervised or controlled by or in conjunction with a religious organization, association or society.

(3) The contractor is a governmental entity.

(4) The sale or lease of city property.

(5) The provision of this section would violate grant requirement, the laws, rules or regulations of federal or state law (for example, The acquisition services procured pursuant to Chapter 287.055, Florida Statutes known as the "Consultants' Competitive Negotiation Act").

(6) Provided that the contractor does not discriminate in the provision of benefits, a contractor may also comply with this section by providing an employee with the cash equivalent of such benefits, if the city manager or his/her designee determines that either:

a. The contractor has made a reasonable yet unsuccessful effort to provide equal benefits. The contractor shall provide the city manager or his/her designee with sufficient proof of such inability to provide such benefit or benefits which shall include the measures taken to provide such benefits or benefits and the cash equivalent proposed, along with its certificate of compliance, as is required under this section.

(7) The city commission waives compliance of this section in the best interest of the city, including but not limited to the following circumstances:

a. The covered contract is necessary to respond to an emergency.

b. Where only one bid response is received.

c. Where more than one bid response is received, but the bids demonstrate that none of the bidders can comply with the requirements of this section.

(f) City's authority to cancel contract. Nothing in this section shall be construed to limit the city's authority to cancel or terminate a contract, deny or withdraw approval to perform a subcontract or provide supplies, issue a non-responsibility finding, issue a non-responsiveness finding, deny a person or entity prequalification, or otherwise deny a person or entity city business.

(g) Timing of application. This section shall be applicable only to covered contracts awarded pursuant to bids which are after the date when this section becomes effective.

ARTICLE 39 "CODES, ORDINANCES, PERMITS, AND LICENSES"

Add the following:

A. PERMIT FOR WORK WITHIN THE FEDERAL, COUNTY, AND/OR STATE RIGHTS-OF-WAY

The Owner will obtain from the county and/or state the necessary permit for work within the rights-of-way. A copy of the permit is available at the office of the Owner. The Contractor shall abide by all regulations and conditions stipulated in the permits, and such conditions and requirements are hereby made a part of these Supplementary Conditions, as fully and completely as though the same were fully set forth herein. The Contractor shall examine the permits granted to the Owner, by the county and/or state. Failure to do so will not relieve the Contractor from compliance with the requirements stated therein.

The Contractor shall prepare, submit, and have approved at his expense traffic maintenance plans required by federal, state, county, and local agencies having jurisdiction.

B. PERMIT FOR WORK WITHIN LOCAL RIGHTS-OF-WAY

The Contractor shall obtain from the City of Key West the necessary permits for work within the rights-of-way. The Contractor shall abide by all regulations and conditions, including maintenance of traffic.

C. NOISE ORDINANCE

City of Key West has a noise ordinance that allows working hours between 8:00 AM to 7:00 PM, Monday through Friday. No work should be performed during weekends or City Holidays, State Holidays and National Holidays. Any construction operations outside these hours and these days will require a variance from the City of Key West Commission.

D. "LICENSES"

**THE BIDDER MUST BE A LICENSED CONTRACTOR BY THE STATE OF FLORIDA AND SUBMIT PROOF OF SUCH WITH THE BID.**

1. Within 10 days of Notice of Award, the successful Bidder must represent that he holds all applicable, county, and City of Key West licenses and permits required to do business as a contractor with respect to the work described in the Contract Documents.

1. Further, the successful Bidder must, within 10 days of Notice of Award, furnish documentation showing that, as a minimum, he has complied with the provisions of Chapter 18 of the Code of Ordinances of the City of Key West in order to enter into the Agreement contained in the Contract Documents.
2. Specifically, within 10 days after Notice of Award, the successful Bidder must demonstrate that he holds, as a minimum, the following licenses and certificates:
  - a.) City of Key West Tax License Receipt;
  - b.) A valid Certificate of Competency issued by the Chief Building Official of Key West, Florida
  - c.) A valid occupational license issued by the City of Key West, Florida.

#### E. WORK DURING HOLIDAYS

There shall be no work during City Holidays, State Holidays and National Holidays. Any construction operations during these days shall be approved by the City of Key West.

#### ARTICLE 42 "SAFETY"

Add the following sub article:

##### OCCUPATIONAL SAFETY AND HEALTH

The Contractor shall observe and comply with all applicable local, state, and federal occupational safety and health regulations during the prosecution of work under this Contract. In addition, full compliance by the Contractor with the U.S. Department of Labor's Occupational Safety and Health Standards, as established in Public Law 91-596, will be required under the terms of this Contract.

#### ARTICLE 43 "PROTECTION OF WORK AND PROPERTY"

Add the following Article:

##### HISTORIC PRESERVATION

The Contractor shall comply with Florida's Archives and Historic Act (Florida Statutes, Chapter 267) and the regulations of the local historic preservation board as applicable and protect against the potential loss or destruction of significant historical or archaeological data, sites, and properties in connection with the project.

#### ARTICLE 57 "OWNERS RIGHT TO TRANSFER EMPLOYMENT"

Add the following Article:

#### TERMINATION FOR CONVENIENCE AND RIGHT OF SUSPENSION

- A. Owner shall have the right to terminate this Contract without cause by written notice of Termination to the Contractor. In the event of such termination for convenience, the Contractor's recovery against the Owner shall be limited to that portion of the Contract amount earned through the date of termination, together with any retainage withheld and reasonable termination expenses incurred. Contractor shall not be entitled to any other or further recovery against the Owner, including, but not limited to, damages or any anticipated profit on portions of the Work not performed.
- B. The Owner shall have the right to suspend all or any portions of the Work upon giving the Contractor prior written notice of such suspension. If all or any portion of the Work is so suspended, the Contractor shall be entitled to reasonable costs, expenses and time extension associated with the suspension.

#### ARTICLE 60 "LIQUIDATED DAMAGES"

Delete Article "LIQUIDATED DAMAGES" in its entirety and substitute the following:  
LIQUIDATED DAMAGES

Should the Contractor fail to complete the work or any part thereof in the time agreed upon in the Contract Documents or within such extra time as may have been allowed for delays by extensions granted as provided in the Contract, the Contractor shall reimburse the Owner for the additional expense and damage for each calendar day, Sundays and legal holidays included, that project outlined in Contract Documents remains uncompleted after the completion date. Liquidated damages shall be assessed. It is agreed that the amount of such additional expense and damage incurred by reason of failure to complete the work is the per diem rate as stipulated in the Proposal. The said amount is hereby agreed upon as a reasonable estimate of the costs which may be accrued by the Owner after the expiration of the time of completion. It is expressly understood and agreed that this amount is not to be considered in the nature of a penalty but as liquidated damages, which have accrued against the Contractor. The Owner shall have the right to deduct such damages from any amount due or that may become due the Contractor or the amount of such damages shall be due and collectible from the Contractor or Surety.

#### ARTICLE 69 "PARTIAL PAYMENTS"

Delete the first paragraph of Article "PARTIAL PAYMENTS" and substitute the following:

No more than once each month the Contractor shall submit to the Engineer a detailed estimate of the amount earned during the preceding month for the separate portions of the work and request payment. As used in this Article the words "amount earned" means the value, on the date of the estimate, for partial payment of the work completed in accordance with the Contract Documents and the value of approved materials delivered to the project site suitably stored and protected prior to incorporation into the work.

#### ARTICLE 69 "PARTIAL PAYMENTS"

Add the following:

Payment will be made by the Owner to the Contractor within 40 days receipt of the written recommendation of payment from the Engineer.

#### ARTICLE 69 "PARTIAL PAYMENT"

Delete Subarticle E "PAYMENT" in its entirety and substitute the following:

##### PAYMENT

After deducting the retainage and the amount of all previous partial payments made to the Contractor from the amount earned the amount due will be made payable to the Contractor. Recommendations for payment received by the Owner less than 40 days prior to the scheduled day for payment will not be processed or paid until the following month.

The OWNER will withhold progress payments until the Contractor has satisfied the above conditions.

#### ARTICLE 72 "FINAL PAYMENT"

Delete Article "FINAL PAYMENT" in its entirety and substitute the following:

##### FINAL PAYMENT

Upon completion of the work the Contractor shall notify the Engineer, in writing, that he has completed it and shall request final payment. The Contractor shall be responsible for keeping an accurate and detailed record of his actual construction. Upon completion of construction and before final acceptance and payment the Contractor shall furnish the Engineer as-built drawings of his construction. Upon receipt of a request for final payment and the as-built drawings the Engineer will inspect and, if acceptable, submit to the Owner his recommendation as to acceptance of the completed work



and as to the final estimate of the amount due the Contractor. Upon approval of this final estimate by the Owner and compliance by the Contractor with provisions in Article RELEASE OF LIENS OR CLAIMS, and other provisions as may be applicable, the Owner shall pay to the Contractor all monies due him under the provisions of these Contract Documents.

#### ARTICLE 72 "FINAL PAYMENT"

Add the following;

##### **A. Acceptance and Final Payment.**

Whenever the Contractor has completely performed the work provided for under the Contract and the Engineer has performed a final inspection and made final acceptance and subject to the terms of the Engineer will prepare a final estimate showing the value of the work as soon as the Engineer makes the necessary measurements and computations. The Engineer will correct all prior estimates and payments in the final estimate and payment. The OWNER will pay the estimate, less any sums that the OWNER may have deducted or retained under the provisions of the Contract, as soon as practicable after final acceptance of the work, provided the Contractor has met the requirements of (1) through (8) below.

- 1 The Contractor has agreed in writing to accept the balance due or refund the overpayment, as determined by the OWNER, as full settlement of his account under the Contract and of all claims in connection therewith, or the Contractor, accepted the balance due or refunded the overpayment, as determined by the OWNER, with the stipulation that his acceptance of such payment or the making of such refund does not constitute any bar, admission, or estoppel, or have any effect as to those payments in dispute or the subject of a pending claim between the Contractor and the OWNER. To receive payment based on a FINAL PAYMENT CERTIFICATE, The Contractor further agrees, by submitting a FINAL PAYMENT CERTIFICATE that any pending or future arbitration claim or suit is limited to those particulars, including the itemized amounts, defined in the original FINAL PAYMENT CERTIFICATE , and that he will commence with any such arbitration claim or suit within 15 calendar days from and after the time of final PAYMENT of the work and that his failure to file a formal claim within this period constitutes his full acceptance of the Engineer's final estimate and payment. The overpayment refund check from the Contractor, if required, will be considered a part of any Acceptance Letter executed.
- 2 The Contractor has properly maintained the project, as specified hereinbefore.
- 3 The Contractor has furnished a sworn affidavit to the effect that the Contractor has paid all bills and no suits are pending (other than those exceptions listed, if any) in connection with work performed under the Contract and that the Contractor has not offered or made any gift or gratuity to, or made any financial

transaction of any nature with, any employee of the OWNER in the performance of the Contract.

- 4 The surety on the contract bond consents, by completion of their portion of the affidavit and surety release subsequent to the Contractor's completion of his portion, to final payment to the Contractor and agrees that the making of such payment does not relieve the surety of any of its obligations under the bond.
- 5 The Contractor has furnished all required mill tests and analysis reports to the Engineer.

\* \* \* \* \*

---

**PART 4**

**SCOPE OF WORK**

---

**SECTION 02012**  
**SCOPE OF WORK**

**PART 1 - SCOPE OF WORK**

**1.1 CONTRACTORS RESPONSIBILITIES**

Construct 100 crypt mausoleum consisting of 100 single vaults with one vertical row of oversized vaults and 40 poured-in-place concrete niches. All poured-in-place Concrete must be 3000 PSI reinforced with grade 60 reinforcing steel.

Crypt fronts and niche fronts are to be Silver Trento polished granite. Trim and wall panels are to be Itatnba Mahogany polished granite. Match existing stone as closely as possible, submit samples for approval. Include six (6) holes per crypt front and four (4) holes per niche opening for plaques and vases (holes to be drilled at factory) all crypt front hanger systems are to be bronze.

This mausoleum will be an addition sharing the back wall of an existing mausoleum. One (1) side crypt end wall will contain the niches. (Olivia Street end) The opposite side crypt end wall and the fascia are to receive a painted concrete finish. A 7' -1 0" sidewalk shall be installed along the front of the crypts, and a 10' -0" sidewalk in front of the niches

Roof is to be Vulkem elastomeric membrane. The roof drainage system shall be installed through the crypts and 5' beyond the building. The end of drainage system pipe will be flagged so the Owner can connect to his drainage system.

Contractor will provide the Owner signed & sealed construction documents (including plans and specifications) which must meet all state and local codes. Upon completion of the project the Contractor will provide the City with signed & sealed as-built drawings in ACAD & PDF format.

Contractor is responsible to obtain all permits necessary.

Contractor is responsible for soils tests and site preparation per soil test reports.

Contractor is responsible to sod area affected by construction as directed by project manager.

Contractor will replace any adjacent sidewalk, asphalt, fences, signs, and structures damaged during construction at his own cost.

Contractor will be responsible for temporary electrical service and temporary water to jobsite.

Contractor will connect to existing drainage system

**1.2 OWNERS RESPONSIBILITIES**

Owner will supply access to jobsite.

Owner has supplied existing mausoleum plan in ATTACHMENTS for informational purposes.

PART 2 - GENERAL:

1.1 DESCRIPTION

- A. Work Included: The design and furnishing of all materials, equipment and labor for the construction of CEMETERY MAUSOLEUMS and all necessary appurtenances and record drawings, surveys, and incidental work to provide a complete and serviceable project identified as:

CE 1003 / KEY WEST CEMETERY MAUSOLEUMS

- B. Related requirements in other parts of the Contract Documents: General Conditions of the Contract for Construction.

- C. Contractor's Duties:

1. In addition to provisions stipulated in other portions of the Contract Documents, the Contractor shall:

- a. Secure permits as necessary for proper execution and completion of the work.
- b. Notify ( in writing) all residents and proprietors adjacent to construction site of work to be performed, more specifically the notice shall state the day and time construction will begin, hours of work, the name and phone number of the Contractor's Superintendent and an end date for the project.

- D. The Contractor shall be totally responsible for all permits required and shall ensure that construction complies with all applicable local, state, and federal codes.

- E. Provide an experienced, qualified, and competent Superintendent to oversee the Work and perform quality assurance inspections. Prior to starting construction, the proposed Superintendent's qualifications shall be submitted in writing to the City for approval. The approved Superintendent shall be expected to remain for the duration of the Project, unless the City or Engineer deem him/her inadequate and requests his/her removal or the Contractor cannot continue his services to the Project for a reason or reasons that shall be communicated in writing to the City.

- F. A replacement Superintendent shall be required to follow the same approval process as required for the original. The Superintendent shall provide to the City Inspector Construction Reports for each day of construction, the reports shall be in English, legible, and signed. Contractor shall provide PDF copies monthly. Reports shall include quantity control checks done daily

- G. It shall be the Contractor's responsibility to request approval for entrance to the site for work on Saturdays, Sundays, holiday, and weekday hours other than 7:00 AM until 7:00 PM. No construction can commence before 8:00 AM on weekdays.
- H. The Contractor shall provide material safety data sheets (2 copies) for chemicals, paints, coatings and materials used on-site prior to initiation of work.
- I. The Contractor shall submit a site Safety and Health Plan as per OSHA 1910.12012.

1.2 CONTRACTOR'S USE OF PREMISES

- A. Work shall be scheduled as to not interfere with on-going area activities.
- B. Coordinate use of premises and requirements for security under direction of City.
- C. Assume full responsibility for the protection and safekeeping of products under this Contract, stored on the site.
- D. Obtain and pay for the use of additional storage or work areas needed for operation.
- E. Contractor shall provide drinking water and toilet facilities for construction personnel; The City will not provide.

1.3 MAINTENANCE OF EXISTING UTILITIES OPERATION

- A. Provide at least three weeks notice prior to interruption of utility services for temporary or permanent connections.
- B. Keep interruption of utility services, and utility outages during disconnection, moving, and reconnection to a minimum.
- C. Keys Energy shall be notified two weeks in advance in writing by the contractor for any KEYS support equipment required by the Contractor during any excavation. (e.g., Power poles next to excavations requiring support, etc.) No additional payment will be paid for this coordination.

\*\*\*\*\*

---

**PART 5**  
**ATTACHMENTS**

---

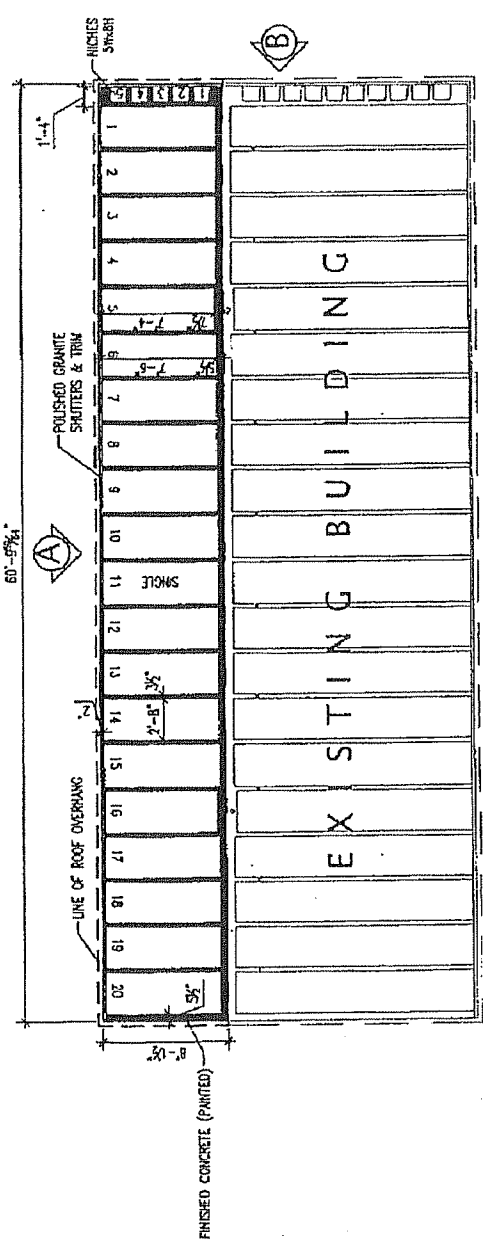

PLAN VIEW

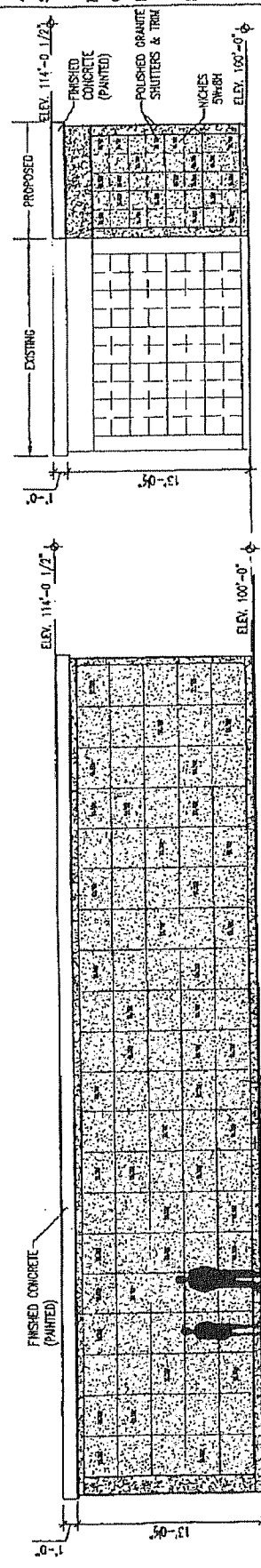

A FRONT ELEVATION

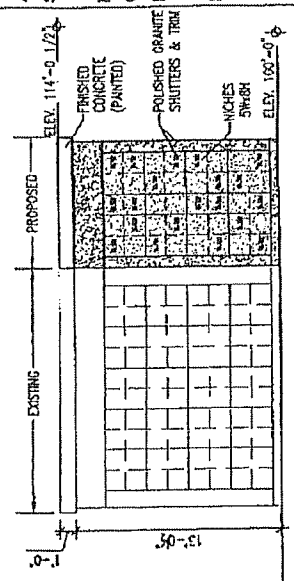

B SIDE ELEVATION

A Mausoleum  
Study Plan for:  
Key West City  
Cemetery  
Key West, FL

Floor Plan  
&  
Elevations

TOTAL CRYPT COUNT 100  
Singles 20@5h= 100  
Niches 5w x 8h = 40





# CITY OF KEY WEST

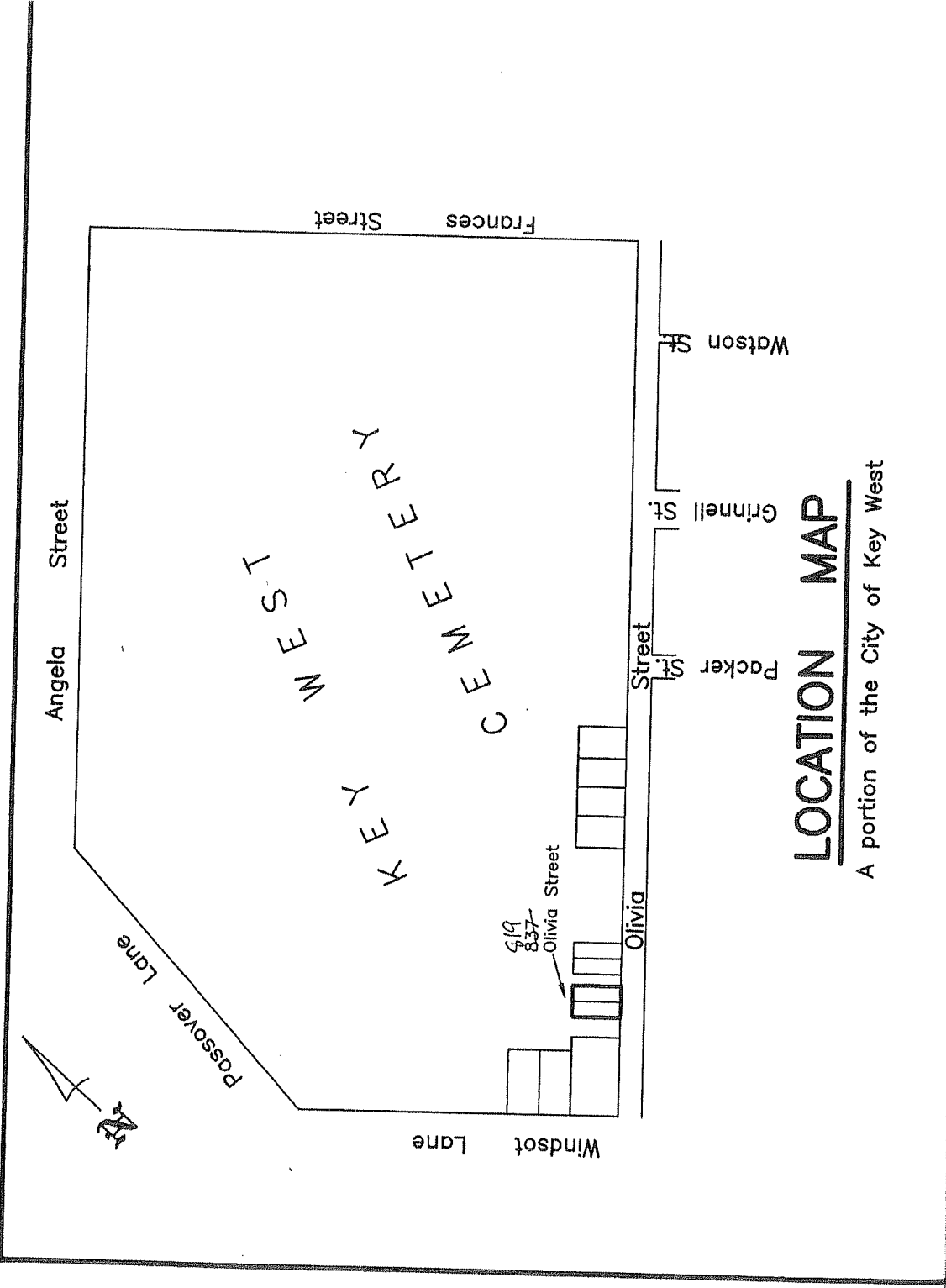

# LOCATION MAP

A portion of the City of Key West

**CITY OF KEY WEST  
CEMETARY**

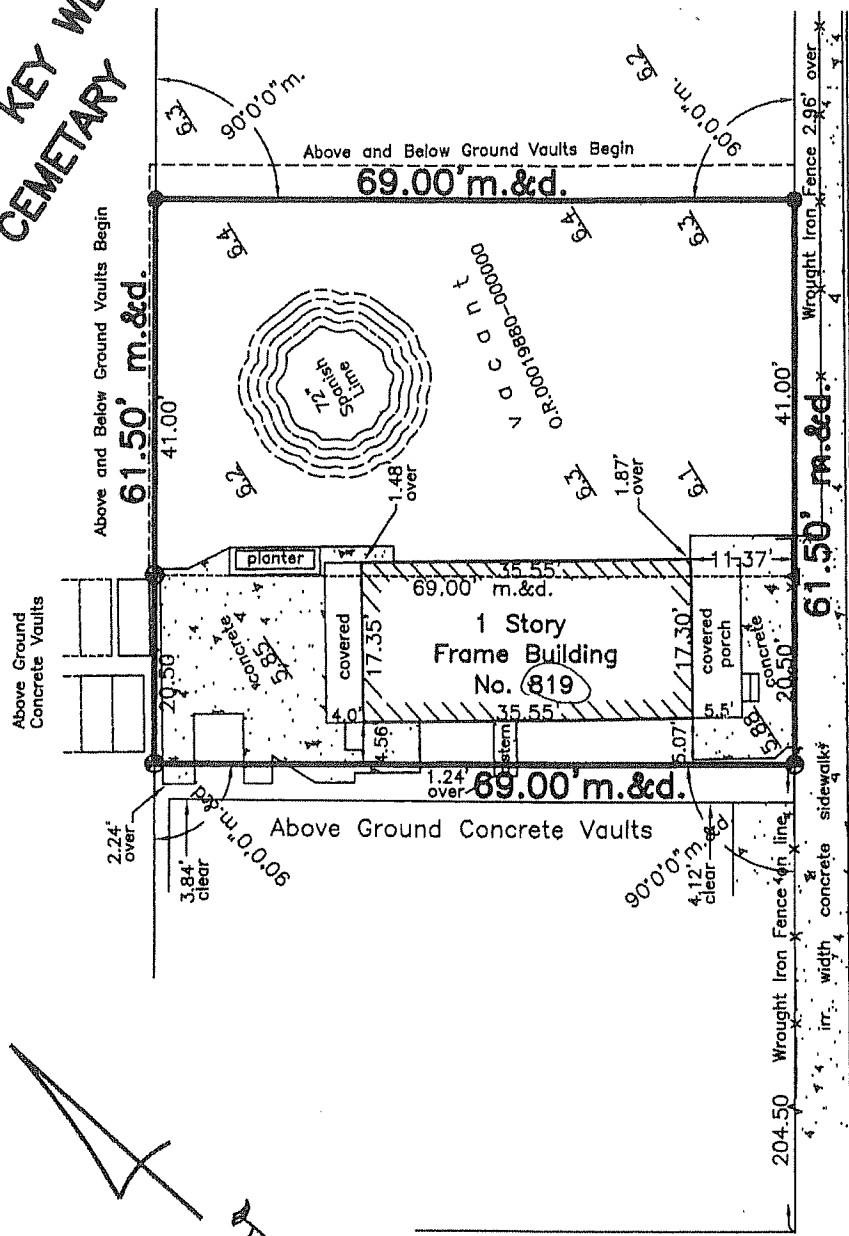

NOTE: All angles are 90°00' unless other wise noted.

NOTE: All distances are measured and deeded unless other wise noted.

**OLVIA STREET (30' R/W)**

**WINDSOR LANE  
(30' R/W)**