

CONTRACT DOCUMENTS FOR:

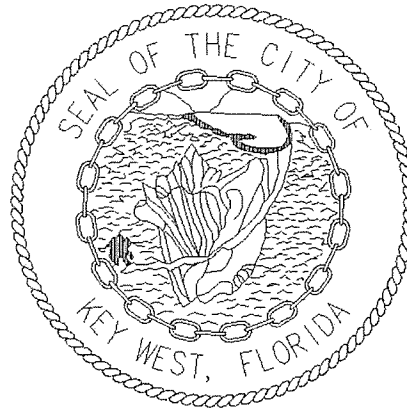

ITB #24-009
FIRE PUMPS REPLACEMENT
KEY WEST HISTORIC SEAPORT
CITY MARINA @ GARRISON BIGHT

MARCH 2024

MAYOR: TERI JOHNSTON

COMMISSIONERS:

JIMMY WEEKLEY

SAMUEL KAUFMAN

BILLY WARDLOW

GREGORY DAVILA

MARY LOU HOOVER

CLAYTON LOPEZ

PREPARED BY:
Port & Marine Services

CITY OF KEY WEST
&
CAROLINE STREET AND BAHAMA VILLAGE COMMUNITY
REDEVELOPMENT AGENCY (CRA)
KEY WEST, FLORIDA

CONTRACT DOCUMENTS

for

FIRE PUMPS REPLACEMENT
KEY WEST HISTORIC SEAPORT
CIT MARINA @ GARRISON BIGHT

CONSISTING OF:
BID REQUIREMENTS
CONTRACT FORMS
CONDITIONS OF THE CONTRACT
SCOPE OF WORK
SPECIFICATIONS
SUPPLEMENTAL INFORMATION

KEY WEST, FLORIDA

March 2024

Table of Contents

	<u>Page No.</u>
PART 1 - <u>BIDDING REQUIREMENTS</u>	
INVITATION TO BID	6
INSTRUCTIONS TO BIDDER	8
BID FORMS	15
FLORIDA BID BOND	27
ANTI – KICKBACK AFFIDAVIT.....	29
FLORIDA STATUTES, ON PUBLIC ENTITY CRIMES.....	30
INDEMNIFICATION FORM.....	32
DOMESTIC PARTNERSHIP AFFIDAVIT.....	33
CONE OF SILENCE AFFIDAVIT.....	34
NON-COLLUSION AFFIDAVIT.....	35
LOCAL VENDORS FORM	36
SCRUTINIZED COMPANIES LIST CERTIFICATION	37
BIDDER'S CHECKLIST	39
PART 2 - <u>CONTRACT</u>	
DRAFT CONTRACT	40
FLORIDA PERFORMANCE BOND.....	42
FLORIDA PAYMENT BOND	44
PART 3 - <u>CONDITIONS OF THE CONTRACT</u>	
GENERAL CONDITIONS OF THE CONTRACT.....	48
SUPPLEMENTARY CONDITIONS.....	66
PART 4 - <u>GENERAL SPECIFICATIONS</u>	
01001 GENERAL REQUIREMENTS.....	77
01010 SCOPE OF WORK.....	85
01014 ENVIRONMENTAL PROTECTION.....	88
01050 FIELD ENGINEERING.....	90
01300 SUBMITTALS.....	92
01500 BARRIERS.....	95
01700 CONTRACT CLOSEOUT.....	97
PART 5 - <u>SUPPLEMENTAL INFORMATION</u>.....	100
LOCATION MAP	
PUMP #1 - KEY WEST BIGHT FERRY TERMINAL - REQUIREMENTS AND SPECIFICATIONS	
PUMP #2 – KEY WEST BIGHT – MARGARET STREET - REQUIREMENTS AND SPECIFICATIONS	
PUMP #3 – CITY MARINA @ GARRISON BIGHT – WEST - REQUIREMENTS AND SPECIFICATIONS	
PUMP #4 – CITY MARINA @ GARRISON BIGHT – EAST - REQUIREMENTS AND SPECIFICATIONS	

PART 1
BIDDING REQUIREMENTS

INVITATION TO BID

Sealed bids for the City of Key West & City of Key West Caroline Street and Bahama Village Community Redevelopment Agency (CRA) **ITB #24-009 FIRE PUMPS REPLACEMENT, KEY WEST HISTORIC SEAPORT & CITY MARINA @ GARRISON BIGHT**, addressed to the City of Key West, will be received at the Office of the City Clerk, 1300 White St., Key West Florida, 33040 until **3:30 pm on May 2, 2024** and then will be publicly opened and read. Any bids received after the time and date specified will not be considered.

Please submit one (1) original bid package and two (2) electronic copies on USB drives with a single PDF file of the entire bid package. Bid package is to be enclosed in a sealed envelope, clearly marked on the outside **“FIRE PUMPS REPLACEMENT, KEY WEST HISTORIC SEAPORT & CITY MARINA @ GARRISON BIGHT - ITB 24-009”** addressed and delivered to the City Clerk at the address noted above.

The project consists of the removal and replacement of four (4) fire pumps with controller, four (4) jockey pumps with controller in existing locations with existing backflows at Key West Historic Seaport (2 locations) and City Marina @ Garrison Bight (2 locations) as per the Scope of Work and Supplemental Information supplied in this document.

The full Invitation to Bid may be obtained from Demand Star by Onvia and The City of Key West website. Please contact Demand Star at www.demandstar.com or call 1-800-711-1712 or www.cityofkeywest-fl.gov

A **Mandatory pre-bid meeting** will be held in the conference room at the KWHS Port and Marine Services Offices, 201 William Street, Key West, Florida on **April 18, 2024 at 2:30 p.m.**

EACH BID MUST BE SUBMITTED ON THE PRESCRIBED FORM AND ACCOMPANIED BY BID SECURITY AS PRESCRIBED IN THE INSTRUCTIONS TO BIDDERS, PAYABLE TO THE CITY OF KEY WEST, FLORIDA, IN AN AMOUNT NOT LESS THAN FIVE (5) PERCENT OF THE AMOUNT BID.

THE BIDDER MUST BE A LICENSED CONTRACTOR BY THE STATE OF FLORIDA AND SUBMIT PROOF OF SUCH WITH THE BID.

The Bidder shall furnish documentation showing that they are in compliance with the licensing requirements of the State and the provisions of Chapter 66 Section 87 of the Code of Ordinances of the City of Key West; within 10 days the following the Notice of Award and must demonstrate that he holds at a minimum, the following licenses & certificates;

- A. City of Key West License, as defined in Code of Ordinances, Chapter 66, enabling the Contractor to perform the work stated herein.
- B. City of Key West Business Tax License Receipt

All bid bonds, contract bonds, insurance contracts, and certificates of insurance shall be either executed by or countersigned by a licensed resident agent of the Surety or Insurance Company having his place of business in the State of Florida, and in all ways complying with the insurance laws of the State of Florida. Further, the said Surety or Insurance Company shall be duly licensed and qualified to do business in the State of Florida.

Before a Contract will be awarded for the work contemplated herein, the City of Key West & CRA will conduct such investigation as is necessary to determine the performance record and ability of the apparent low Bidder to perform the size and type of work specified under this Contract. Upon request, the Bidder shall submit such information as deemed necessary by the City of Key West & CRA to evaluate the Bidder's qualifications.

The City of Key West & CRA hereby notifies all Bidders that it will affirmatively ensure that in any contract entered into pursuant to this advertisement, Disadvantaged Business Enterprise will be afforded full opportunity to submit bids in response to this invitation and will not be discriminated against on the grounds of race, color, gender, religion, age, disability, marital status or national origin in consideration for an award.

For information concerning the proposed work please contact **Karen Olson, Deputy Director, Port and Marine Services** by email at kolson@cityofkeywest-fl.gov. Verbal communications, per the City's "Cone of Silence" ordinance are not allowed.

As stated above at the time of the BID submittal the Bidder must provide satisfactory documentation of State Licenses. The Bidder shall furnish documentation showing that he is in compliance with the licensing requirements of County, and City licenses as would be required within ten days of the award. The successful Bidder must also be able to satisfy the City Attorney as to such insurance coverage and legal requirements as may be demanded by the Proposal in question. The City of Key West & CRA may reject BID for any and/or all of the following reasons: (1) for budgetary reasons, (2) if the proposer misstates or conceals a material fact in its bid, (3) if the proposal does not strictly conform to the law or is non-responsive to the bid requirements, (4) if the proposal is conditional, or (5) if a change of circumstances occurs making the purpose of the proposal unnecessary to the CRA. (6) if such rejection is in the best interest of the City of Key West & CRA. The City of Key West & CRA may also waive any minor formalities or irregularities in any proposal.

The City of Key West & CRA retains the right to award bid to the bidder that best meets the needs of the City.

* * * * *

INSTRUCTIONS TO BIDDERS

1. CONTRACT DOCUMENTS

A. FORMAT

The Contract Documents are divided into parts, divisions, and sections for convenient organization and reference. Generally, there has been no attempt to divide the Specification sections into work performed by the various building trades, work by separate subcontractors, or work required for separate facilities in the Project.

B. DOCUMENT INTERPRETATION

Separate sections contained within these Contract Documents are intended to be mutually cooperative and provide all details reasonably required for the execution of proposed work.

Should there be any doubt as to the meaning or intent of said Contract Documents, the Bidder should request of the Deputy Port and Marine Services Director, in writing (at least 8 calendar days prior to Bid opening (no later than April 24, 2024)) an interpretation thereof. Any interpretation or change in said Contract Documents will be made only in writing in the form of Addenda to the Documents, which will be furnished to all registered holders of Contract Documents. Bidders shall submit with their Bids or indicate receipt of all Addenda. The Owner will not be responsible for any other explanation or interpretations of said Documents.

2. SCOPE OF SERVICES

A general description of the work to be done is contained in the Scope of Work section.

3. REQUIRED QUALIFICATIONS

The prospective Proposers must meet the statutorily prescribed requirements before award of Contract by the City of Key & CRA. Proposers must hold or obtain all licenses and/or certificates as required by the State and Local Statutes in order to bid and perform the work specified herein.

4. BIDDER'S UNDERSTANDING

Each Proposer must inform himself of the conditions relating to the execution of the work and make himself thoroughly familiar with all the Contract Documents. Failure to do so will not relieve the successful Proposer of his obligation to enter into a Contract and complete the contemplated work in strict accordance with the Contract Documents.

Each Proposer shall inform himself of, and the Proposer awarded a Contract shall comply with, federal, state, and local laws, statutes, and ordinances relative to the execution of the work. This requirement includes, but is not limited to, applicable regulations concerning minimum wage rates, nondiscrimination in the employment of labor, protection of public and employee safety and health, environmental protection, the protection of natural resources, fire protection, permits, fees, and similar subjects.

5. TYPE OF BID
UNIT PRICE

The Proposal for the work is to be submitted on a unit price basis. All items required to complete the work specified ~~or shown on the Drawings~~ but not included in the Proposal shall be considered incidental to those set forth in the Proposal. Payment to the Contractor will be made on the measurement of the work actually performed by the Contractor, as specified in the Contract Documents.

The Bidder further proposes to accept as full payment for the Work proposed herein, the amounts computed under the provisions of the Contract Documents and based on the following unit price amounts. The Bidder agrees that the unit prices include all allowances for overhead and profit for each type and unit of work called for in these Contract Documents.

Total allowable cost for Mobilization, General/Supp Conditions and Demobilization (bid schedule line item 1) **shall be 10% maximum of total construction costs (bid schedule line items 4 through 8).**

6. PREPARATION OF BIDS

A. GENERAL

All blank spaces in the BID form must be filled in for all schedules and associated parts, as required, preferably in BLACK INK. All price information shall be clearly shown in both words and figures where required. No changes shall be made in the phraseology of the forms. Written amounts shall govern in case of discrepancy between the amounts stated in writing and the amounts stated in figures. In case of discrepancy between unit prices and extended totals, unit prices shall prevail.

Any BID shall be deemed informal which contains omissions, erasures, alterations, or additions of any kind, or prices uncalled for, or in which any of the prices are obviously unbalanced, or which in any manner shall fail to conform to the conditions of the published Invitation to BID.

Only one BID from any individual, firm, partnership, or corporation, under the same or different names, will be considered. Should it appear to the Owner that any Bidder is interested in more than one BID for work contemplated, all Bids in which such Bidder is interested will be rejected.

B. DESCRIPTION OF SUPPLIERS

Any manufacturer's name, trade name, brand name, or catalog number used in the specifications is for the purpose of describing and establishing general quality levels. SUCH REFERENCES ARE NOT INTENDED TO BE RESTRICTIVE. Bids will be considered for any brand which meets the quality of the specifications for any item.

C. SIGNATURE

The Bidder shall sign his BID in the blank space provided therefore. If Bidder is a corporation, the legal name of the corporation shall be set forth above together with the signature of the officer or officers authorized to sign Contracts on behalf of the corporation. If Bidder is a partnership, the true name of the firm shall be set forth above together with the signature of the partner or partners authorized to sign Contracts on behalf of the partnership. If signature is by an agent, other than an officer of a corporation or a member of a partnership, a notarized power-of-attorney must be on file with the Owner prior to opening of Bids or submitted with the Bid otherwise the Bid will be regarded as not properly authorized.

D. SPECIAL BIDDING REQUIREMENTS

The Bidder's attention is brought to the hiring practices and licenses and permits of the City of Key West. These are defined in addition to Article 39, ORDINANCES, PERMITS, AND LICENSES, as set forth in the Supplementary Conditions.

The Bidder shall submit with his Bid his experience record showing his experience and expertise in fire pump system installation. Such experience record shall provide at least five current or recent projects of similar work, not more than 5 years old within the State Florida and preferably Monroe County. For each project the following information shall be provided:

- i. Description and location of work.
- ii. Contract amount.
- iii. Dates work was performed.
- iv. Owner.
- v. Name of Owner's contact person and phone number.
- vi. Engineer.
- vii. Name of Engineer's contact person and phone number.

The bidder shall submit at least 3 references from the above work experience.

The bidder shall submit with his bid a list of items to be performed by his own labor and that performed by subcontractors or others.

E. ATTACHMENTS

Bidder shall complete and submit the following forms with his bid:

1. Anti-Kickback Affidavit
2. Public Entity Crimes Form
3. City of Key West Indemnification Form
4. Equal Benefits for Domestic Partners Affidavit
5. Cone of Silence
6. Non-Collusion Affidavit
7. Local Vendor Certification
8. Scrutinized Companies List Certification
9. Bidders Checklist
10. Proof of Required Insurance

F. CITY OF KEY WEST LICENSE REQUIRED

Contractors are required to have a Certified or Registered General Contractors City of Key West license. License fees not to exceed \$410.00. License shall be obtained within ten (10) days of Notice of Award.

7. STATE AND LOCAL SALES AND USE TAXES

Unless the Supplementary Conditions contains a statement that the CITY is exempt from state sales tax on materials incorporated into the work due to the qualification of the work under this Contract, all state and local sales and use taxes as required by the laws and statutes of the state and its political subdivisions shall be paid by the Contractor. Prices quoted in the Bid shall include all nonexempt sales and use taxes, unless provision is made in the Bid form to separately itemize the tax.

8. SUBMISSION OF BID

All BIDS must be submitted no later than the time prescribed, at the place, and in the manner set forth in the Invitation to Bid. Bids must be made on the Bid forms provided herewith **submit one (1) ORIGINAL bid package and two (2) FLASH DRIVES containing a single PDF file of the entire bid package.**

Each Bid must be submitted in a sealed envelope, so marked as to indicate the Bidder's name and its contents without being opened and addressed in conformance with the instructions in the Invitation to Bid.

9. MODIFICATION OR WITHDRAWAL OF BID

Prior to the time and date designated for receipt of Bids, any Bid submitted may be withdrawn by notice to the party receiving Bids at the place designated for receipt of Bids. Such notice shall be in writing over the signature of the Bidder or by telegram. If by telegram, written confirmation over the signature of the Bidder shall be mailed and postmarked on or before the date and time set for receipt of Bids. No Bid may be withdrawn after the time scheduled for opening of Bids unless the time specified in paragraph AWARD OF CONTRACT of these Instructions to Bidders shall have elapsed.

10. BID SECURITY

BIDS must be accompanied by cash, a certified check, or cashier's check drawn on a bank in good standing, or a bid bond issued by a Surety authorized to issue such bonds in the state where the work is located, in the amount of five (5) percent of the total amount of the Proposal submitted. This bid security shall be given as a guarantee that the Bidder will not withdraw his BID for a period of ninety (90) days after bid opening, and that if awarded the Contract, the successful Bidder will execute the attached Contract and furnish properly executed Performance and Payment Bonds, each in the full amount of the Contract price within the time specified. Agent and Surety phone numbers must be provided.

The Attorney-in-Fact who executes this bond in behalf of the Surety must attach a notarized copy of his power-of-attorney as evidence of his authority to bind the Surety on the date of execution of the bond. Where State Statute requires, certification by a resident agent shall also be provided.

If the Bidder elects to furnish a Bid Bond, he shall use the Bid Bond form bound herewith,

or one conforming substantially thereto in form and content.

11. RETURN OF BID SECURITY

Within 15 days after the award of the Contract, the CITY will return the bid securities to all Bidders whose BIDS are not to be further considered in awarding the Contract. Retained bid securities will be held until the Contract has been finally executed, after which all bid securities, other than Bidders' bonds and any guarantees, which have been forfeited, will be returned to the respective Bidders whose Proposals they accompanied.

12. AWARD OF CONTRACT

The Award will be made under one Contract by the Owner on the basis of the Bid from the lowest, responsive, responsible Bidder. The Owner may award entire Bid or selected line items based on the City of Key West & CRA's best interest and available funds a time of Award.

Within 90 calendar days after the opening of Bids, the Owner will accept one of the Bids or will act in accordance with the following paragraphs. The acceptance of the Bid will be by written notice of award, mailed to the office designated in the Bid, or delivered to the Bidder's representative. In the event of failure of the lowest responsive, responsible Bidder to sign the Contract and provide an acceptable Performance Bond, Payment Bond, insurance certificate(s) and evidence of holding required licenses and certificates, the Owner may award the Contract to the next lowest responsive, responsible Bidder. Such award, if made, will be made within 120 days after the opening of Bids. Bidders will guarantee their Bid price(s) for up to 120 calendar days after Bid opening.

The City of Key West & CRA reserves the right to accept or reject any or all Bids and to waive any formalities and irregularities in said Bids.

13. BASIS OF AWARD

The award will be made by the Owner on the basis of the BID from the lowest, responsive, responsible BIDDER which, in the Owner's sole and absolute judgment will best serve the interest of the Owner.

14. EXECUTION OF CONTRACT

The successful Bidder shall, within 10 working days after receiving Notice of Award, sign and deliver to the Owner a Contract in the form hereto attached together with the insurance certificate examples of the bonds as required in the Contract Documents and evidence of holding required licenses and certificates. Within 10 working days after receiving the signed Contract from the successful Bidder, the Owner's authorized agent will sign the Contract. Signature by both parties constitutes execution of the Contract.

15. CONTRACT BONDS

A. PERFORMANCE AND PAYMENT BONDS

The successful Bidder shall file with the CITY, at the time of delivery of the signed Contract, a Performance Bond and Payment Bond on the form bound herewith, each in the full amount of the Contract price in accordance with the requirements of

Florida Statutes Section 255.05 or 713.23, as applicable, as security for the faithful performance of the Contract and the payment of all persons supplying labor and materials for the construction of the work, and to cover all guarantees against defective workmanship or materials, or both, during the warranty period following the date of final acceptance of the work by the CITY. The Surety furnishing this bond shall have a sound financial standing and a record of service satisfactory to the CITY, shall be authorized to do business in the State of Florida, and shall be listed on the current U.S. Department of Treasury Circular Number 570, or amendments thereto in the Federal Register, of acceptable Sureties for federal projects. The CONTRACTOR shall supply the OWNER with phone numbers, addresses, and contacts for the Surety and their agents. Pursuant to Section 255.05(7), Florida Statutes, in lieu of the bond required by law, the contractor may file with the city an alternative form of security in the form of cash, a money order, a certified check, a cashier's check or an irrevocable letter of credit.

G. POWER-OF-ATTORNEY

The Attorney-in-Fact (Resident Agent) who executes this Performance and Payment Bond in behalf of the Surety must attach a notarized copy of his power-of-attorney as evidence of his authority to bind the Surety on the date of execution of the bond. All Contracts, Performance and Payment Bonds, and respective powers-of-attorney will have the same date.

16. FAILURE TO EXECUTE CONTRACT AND FURNISH BOND

The Bidder who has a Contract awarded to him and who fails to promptly and properly execute the Contract or furnish the required Bonds shall forfeit the bid security that accompanied his bid, and the bid security shall be retained as liquidated damages by the CITY, and it is agreed that this said sum is a fair estimate of the amount of damages the CITY will sustain in case the Bidder fails to enter into a Contract or furnish the required Bonds. Bid security deposited in the form of cash, a certified check, or cashier's check shall be subject to the same requirement as a Bid Bond.

17. TIME OF COMPLETION

The time of completion of the work to be performed under this Contract is the essence of the Contract. Delays and extensions of time may only be allowed in accordance with the provisions stated in the General Conditions. Time allowed for completion of the work authorized is stated in Bid.

When the Contractor receives a Notice to Proceed, he shall commence work as soon as possible and shall complete all work within the number of calendar days stipulated in the Contract.

The term of this contract will be one hundred-twenty (120) calendar days.

18. PUBLIC RECORDS REQUIREMENTS

In addition to other contract requirements provided by law, each public agency contract for services must include a provision that requires the contractor to comply with public records laws, specifically to (a) keep and maintain public records that ordinarily and necessarily would be required by the public agency in order to perform the service; (b) provide the public with access to public records on the same terms and conditions that the public agency would provide the records and at a cost that does not exceed the cost provided in this chapter or as otherwise provided by law; (c) ensure that public records that are exempt or confidential and exempt from public records disclosure requirements are not disclosed except as authorized by law; and (d) meet all requirements for retaining public records and transfer, at no cost, to the public agency all public records in possession of the contractor upon termination of the contract and destroy any duplicate public records that exempt or confidential and exempt from public records disclosure requirements. All records stored electronically must be provided to the public agency in a format that is compatible with the information technology systems of the public agency. If a contractor does not comply with a public records request, the public agency shall enforce the contract provisions in accordance with the contract.

19. PERMITS AND FEES

The Bidder awarded this project shall procure and pay all permits and licenses, charges, and fees, and give notices necessary and incidental to the due and lawful prosecution of the work, the cost of which shall be included in the fee received for the work, except where separately agreed.

20. BIDDER'S DECLARATION AND UNDERSTANDING

The undersigned, hereinafter called the Bidder, declares that the only persons or parties interested in this Bid are those named herein, that this Bid is, in all respects, fair and without fraud, that it is made without collusion with any official of the Owner, and that the Bid is made without any connection or collusion with any person submitting another Bid on this Contract.

The Bidder further declares that he has carefully examined the Contract Documents and that this Bid is made according to the provisions and under the terms of the Contract Documents, which Documents are hereby made a part of this Bid.

21. SALES AND USE TAXES

The Bidder agrees that all federal, state, and local sales and use taxes are included in the stated unit prices for the work.

* * * * *

BID FORM

To: City of Key West, Florida
Address: 1300 White Street, Key West, Florida 33040
Project Title: **FIRE PUMPS REPLACEMENT
KEY WEST HISTORIC SEAPORT
CITY MARINA @ GARRISON BIGHT**
Project No.: **ITB #24-009**

Bidder's person to contact for additional information on this Bid:

Company Name: All in One Fire INC
Contact Name & Telephone #: William Larroche 305-481-2278
Email Address: Junior @ allinonefire.com

BIDDER'S DECLARATION AND UNDERSTANDING

The undersigned, hereinafter called the Bidder, declares that the only persons or parties interested in this Bid are those named herein, that this Bid is, in all respects, fair and without fraud, that it is made without collusion with any official of the Owner, and that the Bid is made without any connection or collusion with any person submitting another Bid on this Contract.

The Bidder further declares that he has carefully examined the Contract Documents, that he has personally inspected the Project, that he has satisfied himself as to the quantities involved, including materials and equipment, and conditions of work involved, including the fact that the description of the quantities of work and materials, as included herein, is brief and is intended only to indicate the general nature of the work and to identify the said quantities with the detailed requirements of the Contract Documents, and that this Bid is made according to the provisions and under the terms of the Contract Documents, which Documents are hereby made a part of this Proposal.

The Bidder further agrees that the Owner may "non-perform" the work in the event that the low bid is in excess of available funding. Non-performance will be determined prior to Notice of Award.

The intent of the Bid Documents is to describe a functionally complete project (or part thereof) to be constructed in accordance with the Contract Documents. Any work, materials, or equipment that may reasonably be inferred from the Contract Documents, as being required to produce the intended result shall be supplied, whether or not specifically called for in the Contract Documents.

1.0 GENERAL INSURANCE REQUIREMENTS:

1.01 During the Term of the Agreement, the Contractor shall provide, pay for, and maintain with insurance companies satisfactory to the City of Key West, Florida ("City"), the types of insurance described herein.

- 1.02 All insurance shall be from responsible insurance companies eligible to do business in the State of Florida. The required policies of insurance shall be performable in Monroe County, Florida, and shall be construed in accordance with the laws of the State of Florida.
- 1.03 The City shall be specifically included as an additional insured on the Contractor's Liability policies with the exception of the Contractor's Professional Liability policies (if required) and shall also provide the "Severability of Interest" provision (a/k/a "Separation of Insured's" provision). The City's additional insured status should be extended to all Completed Operations coverages.
- 1.04 The Contractor shall deliver to the City, prior to commencing work/activities under the Agreement, properly executed "Certificate(s) of Insurance" setting forth the insurance coverage and limits required herein. The Certificates must be signed by the authorized representative of the insurance company(s) shown on the Certificate of Insurance. In addition, certified, true, and exact copies of the insurance policies required herein shall be provided to the City, on a timely basis, if requested by the City.
- 1.05 If the Contractor fails to provide or maintain the insurance coverages required in this Agreement at any time during the Term of the Agreement and if the Contractor refuses or otherwise neglects to deliver the required Certificate(s) of Insurance signed by the authorized representative of the insurance company(s) to the City, the City may, at the City's sole discretion, terminate or suspend this Agreement and seize the amount of Contractor's performance bond, letter of credit, or other security acceptable to the City).
- 1.06 The Contractor shall take immediate steps to make up any impairment to any Aggregate Policy Limit upon notification of the impairment. If at any time the City requests a written statement from the insurance company(s) as to any impairment to the Aggregate Limit, the Contractor shall promptly authorize and have delivered such statement to the City.
- 1.07 The Contractor authorizes the City and/or its insurance consultant to confirm all information furnished to the City, as to its compliance with its Bonds and Insurance Requirements, with the Contractor's insurance agents, brokers, surety, and insurance carriers.
- 1.08 All insurance coverage of the Contractor shall be primary to any insurance or self-insurance program carried by the City. The City's insurance or self-insurance programs or coverage shall not be contributory with any insurance required of the Contractor in this Agreement.
- 1.09 The acceptance of delivery to the City of any Certificate of Insurance evidencing the insurance coverage and limits required in the Agreement does not constitute approval or agreement by the City that the insurance requirements in the Agreement have been met or that the insurance policies shown in the Certificates of Insurance are in compliance with the Agreement requirements.
- 1.10 No work/activity under this Agreement shall commence or continue unless and until the required Certificate(s) of Insurance are in effect and the written Notice to Proceed is issued by the City.
- 1.11 The insurance coverage and limits required of the Contractor under this Agreement are designed to meet the minimum requirements of the City. They are not designed as a recommended insurance program for the Contractor. The Contractor alone shall be responsible for the sufficiency of its own insurance program. Should the Contractor have any question concerning its exposures to loss under this Agreement or the possible insurance coverage needed therefore,

it should seek professional assistance.

- 1.12 During the Term of this Agreement, the City and its agents and contractors may continue to engage in necessary business activities during the operations of the Contractor. No personal property owned by City used in connection with these business activities shall be considered by the Contractor's insurance company as being in the care, custody, or control of the Contractor.
- 1.13 Should any of the required insurances specified in this Agreement provide for a deductible, self-insured retention, self-insured amount, or any scheme other than a fully insured program, the Contractor shall be responsible for all deductibles and self-insured retentions.
- 1.14 All of the required insurance coverages shall be issued as required by law and shall be endorsed, where necessary, to comply with the minimum requirements contained herein.
- 1.15 The Contractor shall provide the City thirty (30) days advance written notice of any cancellation, intent not to renew any policy and/or any change that will reduce the insurance coverage required in this Agreement, except for the application of the Aggregate Limits Provisions.
- 1.16 Renewal Certificate(s) of Insurance shall be provided to the City at least twenty (20) days prior to expiration of current coverage so that there shall be no termination of the Agreement due to lack of proof of the insurance coverage required of the Contractor.
- 1.17 If the Contractor utilizes contractors or sub-contractors to perform any operations or activities governed by this Agreement, the Contractor will ensure all contractors and sub-contractors to maintain the same types and amounts of insurance required of the Contractor. In addition, the Contractor will ensure that the contractor and sub-contractor insurances comply with all of the Insurance Requirements specified for the Contractor contained within this Agreement. The Contractor shall obtain Certificates of Insurance comparable to those required of the Contractor from all contractors and sub-contractors. Such Certificates of Insurances shall be presented to the City upon request. Contractor's obligation to ensure that all contractor's and sub-contractor's insurance as provided herein shall not exculpate Contractor from the direct primary responsibility Contractor has to the City hereunder. The City will look directly to Contractor for any such liability hereunder and shall not be obligated to seek recovery from any contractor or subcontract or under such contractor's or sub-contractor's insurance coverages.

2.0 SPECIFIC INSURANCE COVERAGES AND LIMITS:

- 2.01 All requirements in this Insurance Section shall be complied with in full by the Contractor unless excused from compliance in writing by the City.
- 2.02 The amounts and types of insurance must conform to the following minimum requirements. Current Insurance Service Office (ISO) or National Council on Compensation Insurance (NCCI) policies, forms, and endorsements or broader shall be used where applicable. Notwithstanding the foregoing, the wording of all policies, forms, and endorsements must be acceptable to the City.

Workers' Compensation and Employers' Liability Insurance shall be maintained in force during the Term of this Agreement for all employees engaged in this work under this Agreement, in accordance with the laws of the State of Florida. The minimum acceptable limits shall be:

Workers' Compensation	Florida Statutory Requirements
Employer's Liability	\$100,000.00 Limit Each Accident

\$500,000.00 Limit Disease Aggregate
\$100,000.00 Limit Disease Each
Employee

If the Contractor has less than four (4) employees and has elected not to purchase Workers' Compensation/Employers Liability coverage as permitted by *Florida Statutes*, the Contractor will be required to issue a formal letter (on the Contractor's letterhead) stating that it has less than four (4) employees and has elected not to purchase Workers' Compensation/Employers Liability coverage as permitted by *Florida Statutes*. This exception does **not** apply to firms engaged in construction activities.

Commercial General Liability Insurance shall be maintained by the Contractor on a Full Occurrence Form. Coverage shall include, but not be limited to, Premises and Operations, Personal Injury, Contractual for this Agreement, Independent Contractors, and Products & Completed Operations Coverage. The limits of such coverage shall not be less than:

Bodily Injury & Property Damage Liability	\$1,000,000.00 Combined Single Limit each Occurrence and Aggregate
--	---

Completed Operations Liability Coverage shall be maintained by the Contractor for a period of not less than four (4) years following expiration or termination of this Agreement.

The use of an Excess, Umbrella and/or Bumbershoot policy shall be acceptable if the level of protection provided by the Excess, Umbrella and/or Bumbershoot policy is equal to or more comprehensive than the Primary Commercial General Liability policy.

Business Automobile Liability Insurance shall be maintained by the Contractor as to ownership, maintenance, use, loading and unloading of all owned, non-owned, leased, or hired vehicles with limits of such coverage of not less than:

\$200,000 per Person; \$300,000 per Occurrence \$200,000 Property Damage or \$300,000 Combined Single Limit

If the Contractor does not own any vehicles, this requirement can be satisfied by having the Contractor's Commercial General Liability policy endorsed with "Non-Owned and Hired Automobile" Liability coverage.

Installation Floater Insurance shall be maintained by the Contractor that will provide coverage for machinery and equipment while being transported, installed, and tested. The minimum acceptable limits of such coverage shall be not be less than the value of the machinery or equipment being installed. **City shall be designated as the "Loss Payee" on the policy.**

SURETY AND INSURER QUALIFICATIONS

All bonds, insurance contracts, and certificates of insurance shall be either executed by or countersigned by a licensed resident agent of the Surety or insurance company, having his place of business in the State of Florida, and in all ways complying with the insurance laws of the State of

Florida. Further, the said Surety or insurance company shall be duly licensed and qualified to do business in the State of Florida.

START OF CONSTRUCTION AND CONTRACT COMPLETION TIME

The Bidder agrees to begin work within fourteen (14) calendar days after the date of the Notice to Proceed and to fully complete all work under this contract within one hundred-twenty (120) calendar days, including construction of the foundation and assembly of the structure.

LIQUIDATED DAMAGES

In the event the Bidder is awarded the Contract and fails to complete the work within the time limit or extended time limit agreed upon, as more particularly set forth in the Contract Documents, liquidated damages shall be paid to the Owner at the rate of **\$500.00** per day for all work awarded until the work has been satisfactorily completed as provided by the Contract Documents. Sundays and legal holidays shall be excluded in determining days in default.

Owner will recover such liquidated damages by deducting the amount owed from the final payment or any retainage held by Owner.

ADDENDA

The Bidder hereby acknowledges that he has received Addenda No's. 1, _____, _____, _____. (Bidder shall insert No. of each Addendum received) and agrees that all addenda issued are hereby made part of the Contract Documents, and the Bidder further agrees that his Bid(s) includes all impacts resulting from said addenda.

SALES AND USE TAXES

The Bidder agrees that all federal, state, and local sales and use taxes are included in the stated bid prices for the work.

UNIT PRICE WORK ITEMS

The Bidder further proposes to accept as full payment for the Work proposed herein the amounts computed under the provisions of the Contract Documents and based on the following unit price amounts.

The Bidder agrees that the unit price represent a true measure of labor and materials required to perform the Work, including all allowances for overhead and profit for each type of work called for in these Contract Documents. The amounts shall be shown in both words and figures. In case of discrepancy, the amount shown in words shall govern.

* * * * *



PORT & MARINE SERVICES

201 William Street
Key West, FL
33040

ADDENDUM NO. 1

FIRE PUMPS REPLACEMENT KEY WEST HISTORIC SEAPORT CITY MARINA @ GARRISON BIGHT ITB #24-009

The information contained in this Addendum adds information to be included in the Bid and is hereby made a part of the Contract Documents. The referenced bid package is hereby addended in accordance with the following items:

GENERAL NOTES:

1. Mandatory Pre-Bid sign-in sheet attached.

QUESTIONS/ CLARIFICATIONS:

1. Will all four (4) backflows be replaced as stated in the pre-bid meeting?

Yes, all four (4) existing backflows will be replaced to match existing. See attached revised Bid Schedule.

2. Evidence of an occupational license issued by the bidder's home City, or the City of Key West, is required.
3. Bid documents state that an electrical contractor must perform the electrical scope of the replacement of the pump and the panel, is the city providing the electrical contractor or will we have to provide said electrical contractor?

It is the contractor's responsibility to permit and provide all aspects of this project.

4. Bid docs state the fire pump contractor must have a Fire Protection I License, we are a Fire Protection II contractor, are we permitted to do this job under a Fire Protection II License.

Contractor awarded Bid shall hold a Fire Protection I or II license.

5. Bid documents state to replace the FDC, the fire pumps have a test header not an FDC, the FDC is separate from the fire pump, could the bid docs mean the test headers instead of the FDC's?

Contractor to provide FDC's as noted. Test Headers are part of pump package.

6. Will a Fire Watch be required during replacement?

No, however, if a circumstance arises that would require a Fire Watch payment would be made from the Allowance line item.

All other elements of the Contract and Bid documents, including the Bid Date shall remain unchanged. All Bidders shall acknowledge receipt and acceptance of this **Addendum No. 1** by submitting the addendum with their proposal. Proposals submitted without acknowledgement or without this Addendum may be considered non-responsive.



Signature

All in One Fire, INC
Name of Business

**FIRE PUMPS REPLACEMENT
KEY WEST HISTORIC SEAPORT & CITY MARINA @ GARRISON BIGHT
ITB #24-009**

Mandatory Pre-Bid Meeting SIGN-IN Sheet

April 18, 2024
2:30 PM

NAME / COMPANY	CONTACT #	EMAIL
Steve McAlearney / City of Key West	305-809-3792	smcalearney@cityofkeywest-fl.gov
Karen Olson / City of Key West	305-809-3803	kolson@cityofkeywest-fl.gov
Tim Tychan / City of Key West	305-809-3778	timothy.tychan@cityofkeywest-fl.gov

Ben Leonard / Gary's Plumbing and Fire	772-249-6324	Ben@GarysPlumbingandFire.com
James Bogoff / Florida Keys Fire	305-509-2409	FloridaKeysFire@gmail.com
Dave Henderson / Fire Pump Guy Sales	954-593-0512	dave@firepumpguy.com
MARCELLINO DE CELIS / ARUSSARY FLUID TECHNOLOGY	813-467-3179	mdecelis@arussaryfluidtechnology.com
Jesse Baker / Armstrong Fluid Technology	906-878-8496	jbaker@armstrongfluidtechnology.com
Yasser Morales / FPS	305-321-1954	yasser.morales@fps.us
Jason Brownlee / Reynolds Construction	601-344-8970	Jason.Brownlee@reynoldson.com
Jacob Long / Reynolds Construction	662-444-8042	Jacob.Long@reynoldson.com
Matthew Alaman / All in one Fire	736-981-3473	Matthew@allinonefire.com

**BID SCHEDULE
ITB #24-009**

**FIRE PUMPS REPLACEMENT
KEY WEST HISTORIC SEAPORT (KWB)
CITY MARINA @ GARRISON BIGHT (GB)**

UNIT PRICE BID

Bid unit prices stated in this proposal include all costs and expenses for labor, equipment, materials, disposal and contractor's overhead and profit. Unit prices for the various work items are intended to establish a total price for completing the project in its entirety. All work and incidental costs shall be included for payment under the several scheduled items of the overall contract, and no separate payment will be made therefore.

1. Mobilization, General/Supp Conditions and Demobilization

a.	Mobilization	1	each	\$ <u>7,500</u>
b.	General/Supp. Conditions	1	each	\$ <u>3,000</u>
c.	Demobilization	1	each	\$ <u>2,000</u>
	1	LS	(a, b, c combined) (10% of Const. Cost Max.)	\$ <u>12,500.00</u>

2. Payment and Performance Bonds

1	LS	\$ <u>20,047.78</u>
---	----	---------------------

3. Permit Fees (to be paid at cost)

1	LS	\$ <u>23,000.00</u>
---	----	---------------------

4. **Pump #1** KWB Ferry Terminal: Fire Pump, Jockey Pump, Controllers, Valves, FDC, Piping and Equipment as described in the Supplemental Information (Includes all labor, removal & disposal of existing, equipment, and materials for a complete product)

1	LS	\$ <u>77,514.12</u>
---	----	---------------------

5. **Pump #2** KWB Margaret St: Fire Pump, Jockey Pump, Controllers, Valves, FDC, Piping and Equipment as described in the Supplemental Information (Includes all labor, removal & disposal of existing, equipment, and materials for a complete product)

1	LS	\$ <u>78,835.46</u>
---	----	---------------------

6. **Pump #3 GB West:** Fire Pump, Jockey Pump, Controllers, Valves, FDC, Piping and Equipment as described in the Supplemental Information (Includes all labor, removal & disposal of existing, equipment, and materials for a complete product)

1 LS \$ 79,552.96

7. **Pump #4 GB East:** Fire Pump, Jockey Pump, Controllers, Valves, FDC, Piping and Equipment as described in the Supplemental Information (Includes all labor, removal & disposal of existing, equipment, and materials for a complete product)

1 LS \$ 79,552.96

8. Allowance (only to be used with owner's written directive)

1 LS \$ 50,000

TOTAL OF ALL EXTENDED LINE ITEMS LISTED ABOVE:

Total of lump sum items 1 - 8 \$ 421,008.28

Four hundred twenty-one thousand and three Dollars & twenty-eight Cents
(amount written in words)

NOTE: THE TOTAL BID WILL BE THE BASIS OF EVALUATING LOW BIDDER AND BASIS OF AWARD

The Bidder shall submit a Schedule of Values with the Bid. It shall be broken down by trade and type of work and it shall be used as a basis for payment. The Bidder will be considered non-responsive if Schedule of Values not included in Bid package.

Payment for materials and equipment authorized by the ENGINEER in a written Change Order but not listed in the above Bid will be provided at the supplier's invoice plus 10 %.

Total allowable cost for Mobilization, General/Supp Conditions and Demobilization (bid schedule line item 1) shall be 10% maximum of total construction costs (bid schedule line items 4 through 8).

List items to be performed by CONTRACTOR's own forces and the estimated total cost of these items.
(Use additional sheets if necessary.)

Removal and discarding of existing equipment - \$ 7,700.00 per fire pump

For lift rental - \$ 3,000.00

Installation of new equipment - 315,455.50

This includes all material, labor, and fire pump start-up for all fire pumps.

also includes the electrical disconnect and reconnect by our electrical contractor as well as the fire pump start-up.

SUBCONTRACTORS

The Bidder further proposes that the following subcontracting firms or businesses will be awarded subcontracts for the following portions of the work in the event that the Bidder is awarded the Contract:

305 Power Corp
Name

16250 SW 96th Terr, Miami, FL, 33196
Street City State Zip

Name

_____, _____, _____, _____
Street City State Zip

Name

_____, _____, _____, _____
Street City State Zip

Name

_____, _____, _____, _____
Street City State Zip

SURETY

Old Republic Surety Company whose address is
P.O. Box 1635, Milwaukee, WI, 53201
Street City State Zip

BIDDER

The name of the Bidder submitting this Proposal is

All in One Fire, Inc doing business at
8350 NW 52nd Terr. Ste 301, Doral, FL, 33166
Street City State Zip

which is the address to which all communications concerned with this Proposal and with the Contract shall be sent.

The names of the principal officers of the corporation submitting this Proposal, or of the partnership, or of all persons interested in this Proposal as principals are as follows:

Name	Title
<u>William Carroche</u>	<u>President</u>
<u>Matthew Aleman</u>	<u>Director of Sales</u>
_____	_____
_____	_____
_____	_____

If Sole Proprietor or Partnership

IN WITNESS hereto the undersigned has set his (its) hand this _____ day of _____ 2024.

Signature of Bidder

Title

If Corporation

IN WITNESS WHEREOF the undersigned corporation has caused this instrument to be executed and its seal affixed by its duly authorized officers this 1 day of May 2024.

(SEAL)

All in One Fire, Inc
Name of Corporation

By William Larroche 

Title President

Attest Renealdo Perez 
Secretary

EXPERIENCE OF BIDDER

The Bidder states that he is an experienced CONTRACTOR and has completed similar projects within the last 5 years.

(List similar projects, with types, names of OWNERS, construction costs, ENGINEERS, and references with phone numbers. Use additional sheets if necessary.)

• Miami: Dade County - Pelican Reef - The addition of fire
Hoses & Repair of Deficiencies - \$232,500.00 - Omar Rivero
305-510-6944

• Miami Dade County - Crandon Park Marina - The
Installation of Hangers onto the floating docks
& fire Sprinkler System. \$29,900.00 - Omar
Rivero 305-510-6944

• Carroll Management - Arrium Properties - The
Repair of the Deficiencies in (5) different
Arrium locations. \$328,000.00 - Sean Herl
561-531-3564

• Mendon Management - Aria Condo - The
Replacement of the Existing fire pump. \$44,000.00
Sheri Coury 954-284-3300

FLORIDA BID BOND

BOND NO. N/A

AMOUNT: \$ N/A

KNOW ALL MEN BY THESE PRESENTS, that All In One Fire, Inc.

8350 NW 52nd Terrace, Unit 301, Doral Fl 33166

hereinafter called the PRINCIPAL, and Old Republic Surety Company

a corporation duly organized under the laws of the State of Wisconsin

having its principal place of business at PO Box 1635

Milwaukee, WI 53201-1635 in the State of Wisconsin,

and authorized to do business in the State of Florida, as SURETY, are held and firmly bound unto

City of Key West 1300 White Street, Key West Florida 33040

hereinafter called the OBLIGEE, in the sum of Five Percent Of The Total Amount Bid

DOLLARS (\$5% Of The Total Amount Bid) for the payment for which we bind

ourselves, our heirs, executors, administrators, successors, and assigns, jointly and severally,

firmly by these present.

THE CONDITION OF THIS BOND IS SUCH THAT:

WHEREAS the PRINCIPAL is herewith submitting his or its Bid Proposal for **ITB #24-009
FIRE PUMPS REPLACEMENT - KEY WEST HISTORIC SEAPORT & CITY MARINA
@ GARRISON BIGHT**, said Bid Proposal, by reference thereto, being hereby made a part
hereof.

WHEREAS, the PRINCIPAL contemplates submitting or has submitted a bid to the OBLIGEE for the furnishing of all labor, materials (except those to be specifically furnished by the CITY), equipment, machinery, tools, apparatus, means of transportation for, and the performance of the work covered in the Proposal and the detailed Specifications, entitled:

ITB #24-009

FIRE PUMPS REPLACEMENT

KEY WEST HISTORIC SEAPORT & CITY MARINA @ GARRISON BIGHT

WHEREAS, it was a condition precedent to the submission of said bid that a cashier's check, certified check, or bid bond in the amount of 5 percent of the base bid be submitted with said bid as a guarantee that the Bidder would, if awarded the Contract, enter into a written Contract with the CITY for the performance of said Contract, within 10 working days after written notice having been given of the award of the Contract.

NOW, THEREFORE, the conditions of this obligation are such that if the PRINCIPAL within 10 consecutive calendar days after written notice of such acceptance, enters into a written Contract with the OBLIGEE and furnishes the Performance and Payment Bonds, each in an amount equal to 100 percent of the base bid, satisfactory to the CITY, then this obligation shall be void; otherwise the sum herein stated shall be due and payable to the OBLIGEE and the Surety herein agrees to pay said sum immediately upon demand of the OBLIGEE in good and lawful money of the United States of America, as liquidated damages for failure thereof of said PRINCIPAL.

Signed and sealed this 29th day of April, 2024.

By _____
PRINCIPAL All In One Fire, Inc.

Old Republic Surety Company
SURETY

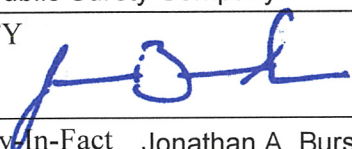
By  _____
Attorney-In-Fact Jonathan A. Bursevich





OLD REPUBLIC SURETY COMPANY

POWER OF ATTORNEY

KNOW ALL MEN BY THESE PRESENTS: That OLD REPUBLIC SURETY COMPANY, a Wisconsin stock insurance corporation, does make, constitute and appoint: **WARREN M. ALTER, DAVID T. SATINE, JONATHAN A. BURSEVICH** of MIAMI LAKES, FL

its true and lawful Attorney(s)-in-Fact, with full power and authority for and on behalf of the company as surety, to execute and deliver and affix the seal of the company thereto (if a seal is required), bonds, undertakings, recognizances or other written obligations in the nature thereof, **(other than bail bonds, bank depository bonds, mortgage deficiency bonds, mortgage guaranty bonds, guarantees of installment paper and note guaranty bonds, self-insurance workers compensation bonds guaranteeing payment of benefits, or black lung bonds)**, as follows:

ALL WRITTEN INSTRUMENTS

and to bind OLD REPUBLIC SURETY COMPANY thereby, and all of the acts of said Attorneys-in-Fact, pursuant to these presents, are ratified and confirmed. This appointment is made under and by authority of the board of directors at a special meeting held on February 18, 1982.

This Power of Attorney is signed and sealed by facsimile under and by the authority of the following resolutions adopted by the board of directors of the OLD REPUBLIC SURETY COMPANY on February 18, 1982.

RESOLVED that, the president, any vice-president or assistant vice president, in conjunction with the secretary or any assistant secretary, may appoint attorneys-in-fact or agents with authority as defined or limited in the instrument evidencing the appointment in each case, for and on behalf of the company to execute and deliver and affix the seal of the company to bonds, undertakings, recognizances, and suretyship obligations of all kinds; and said officers may remove any such attorney-in-fact or agent and revoke any Power of Attorney previously granted to such person.

RESOLVED FURTHER, that any bond, undertaking, recognizance, or suretyship obligation shall be valid and binding upon the Company

- (i) when signed by the president, any vice president or assistant vice president, and attested and sealed (if a seal be required) by any secretary or assistant secretary; or
- (ii) when signed by the president, any vice president or assistant vice president, secretary or assistant secretary, and countersigned and sealed (if a seal be required) by a duly authorized attorney-in-fact or agent; or
- (iii) when duly executed and sealed (if a seal be required) by one or more attorneys-in-fact or agents pursuant to and within the limits of the authority evidenced by the Power of Attorney issued by the company to such person or persons.

RESOLVED FURTHER that the signature of any authorized officer and the seal of the company may be affixed by facsimile to any Power of Attorney or certification thereof authorizing the execution and delivery of any bond, undertaking, recognizance, or other suretyship obligations of the company; and such signature and seal when so used shall have the same force and effect as though manually affixed.

IN WITNESS WHEREOF, OLD REPUBLIC SURETY COMPANY has caused these presents to be signed by its proper officer, and its corporate seal to be affixed this 5th day of April, 2023

Karen J. Haffner
Assistant Secretary



OLD REPUBLIC SURETY COMPANY

Alan Pavlic
President

STATE OF WISCONSIN, COUNTY OF WAUKESHA - SS

On this 5th day of April, 2023, personally came before me, Alan Pavlic and Karen J Haffner, to me known to be the individuals and officers of the OLD REPUBLIC SURETY COMPANY who executed the above instrument, and they each acknowledged the execution of the same, and being by me duly sworn, did severally depose and say: that they are the said officers of the corporation aforesaid, and that the seal affixed to the above instrument is the seal of the corporation, and that said corporate seal and their signatures as such officers were duly affixed and subscribed to the said instrument by the authority of the board of directors of said corporation.



Kathryn R. Pearson
Notary Public

My Commission Expires: September 28, 2026

(Expiration of notary's commission does not invalidate this instrument)

CERTIFICATE

I, the undersigned, assistant secretary of the OLD REPUBLIC SURETY COMPANY, a Wisconsin corporation, CERTIFY that the foregoing and attached Power of Attorney remains in full force and has not been revoked; and furthermore, that the Resolutions of the board of directors set forth in the Power of Attorney, are now in force.

92-3000



Signed and sealed at the City of Brookfield, WI this 2nd day of May, 2024

Karen J. Haffner
Assistant Secretary

ORSC 22262 (3-06)

ALTER SURETY GROUP INC

ANTI-KICKBACK AFFIDAVIT

STATE OF Florida)

: SS

COUNTY OF Miami-Dade

I, the undersigned hereby duly sworn, depose and say that no portion of the sum herein bid will be paid to any employees of the City of Key West as a commission, kickback, reward or gift, directly or indirectly by me or any member of my firm or by an officer of the corporation.

By:  _____

Sworn and subscribed before me this 1 day of May 2024.

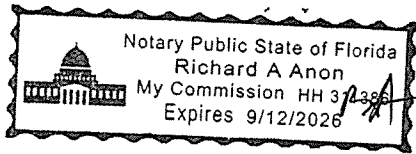

NOTARY PUBLIC, State of Florida at Large

My Commission Expires:

* * * * *

**SWORN STATEMENT UNDER SECTION 287.133(3)(A)
FLORIDA STATUTES, ON PUBLIC ENTITY CRIMES**

THIS FORM MUST BE SIGNED IN THE PRESENCE OF A NOTARY PUBLIC OR OTHER OFFICER AUTHORIZED TO ADMINISTER OATHS.

1. This sworn statement is submitted with Bid or Proposal for Fire Pump replacement ISWB City marina
ⓐ GB - ITB # 24-009

2. This sworn statement is submitted by All in One Fire, INC
(name of entity submitting sworn statement)

whose business address is 8350 NW 52nd Terr, Ste. 301,
Doral, FL 33166

and (if applicable) its Federal Employer Identification Number (FEIN) is 93-2054478

(If the entity has no FEIN, include the Social Security Number of the individual

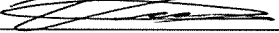
signing this sworn statement 

3. My name is William Larroche
(please print name of individual signing)

and my relationship to the entity named above is President

4. I understand that a “public entity crime” as defined in Paragraph 287.133(1)(g), Florida Statutes, means a violation of any state or federal law by a person with respect to and directly related to the transaction of business with any public entity or with an agency or political subdivision of any other state or with the United States, including but not limited to, any bid or contract for goods or services to be provided to any public or an agency or political subdivision of any other state or of the United States and involving antitrust, fraud, theft, bribery, collusion, racketeering, conspiracy, material misrepresentation.

5. I understand that “convicted” or “conviction” as defined in Paragraph 287.133(1)(b), Florida Statutes, means a finding of guilt or a conviction of a public entity crime, with or without an adjudication of guilt, in any federal or state trial court of record relating to charges brought by indictment information after July 1, 1989, as a result of a jury verdict, nonjury trial, or entry of a plea of guilty or nolo contendere.

6. I understand that an “affiliate” as defined in Paragraph 287.133(1)(a), Florida Statutes, means

- a. A predecessor or successor of a person convicted of a public entity crime; or
- b. An entity under the control of any natural person who is active in the management of the entity and who has been convicted of a public entity crime. The term “affiliate” includes those officers, directors, executives, partners, shareholders, employees, members, and agents who are active in the management of an affiliate. The ownership by one person of shares constituting controlling interest in another person, or a pooling of equipment or income among persons when not for fair market value under an arm’s length agreement, shall be a prima facie case that one person controls another person. A person who knowingly enters into a joint venture with a person who has been convicted of a public entity crime in Florida during the preceding 36 months shall be considered an affiliate.

7. I understand that a "person" as defined in Paragraph 287.133(1)(8), Florida Statutes, means any natural person or entity organized under the laws of any state or of the United States with the legal power to enter into a binding contract and which bids or applies to bid on contracts for the provision of goods or services let by a public entity, or which otherwise transacts or applies to transact business with public entity. The term "person" includes those officers, directors, executives, partners, shareholders, employees, members, and agents who are active in management of an entity.
8. Based on information and belief, the statement which I have marked below is true in relation to the entity submitting this sworn statement. (Please indicate which statement applies).

Neither the entity submitting this sworn statement, nor any officers, directors, executives, partners, shareholders, employees, members, or agents who are active in management of the entity, nor any affiliate of the entity have been charged with and convicted of a public entity crime subsequent to July 1, 1989, AND (Please indicate which additional statement applies.)

There has been a proceeding concerning the conviction before a hearing of the State of Florida, Division of Administrative Hearings. The final order entered by the hearing officer did not place the person or affiliate on the convicted vendor list. (Please attach a copy of the final order.)

The person or affiliate was placed on the convicted vendor list. There has been a subsequent proceeding before a hearing officer of the State of Florida, Division of Administrative Hearings. The final order entered by the hearing officer determined that it was in the public interest to remove the person or affiliate from the convicted vendor list. (Please attach a copy of the final order.)

The person or affiliate has not been put on the convicted vendor list. (Please describe any action taken by or pending with the Department of General Services.)



 (signature)

5/1/2024

 (date)

STATE OF Florida

COUNTY OF Miami-Dade

PERSONALLY APPEARED BEFORE ME, the undersigned authority,

William Larrache who, after first being sworn by me, affixed his/her
 (name of individual signing)

signature in the space provided above on this 1 day of May, 2024.

My commission expires:

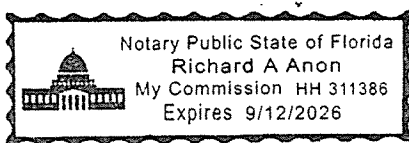

BA

 NOTARY PUBLIC

CITY OF KEY WEST INDEMNIFICATION FORM

To the fullest extent permitted by law, the CONTRACTOR expressly agrees to indemnify and hold harmless the City of Key West, their officers, directors, agents and employees *(herein called the "indemnitees") from liabilities, damages, losses and costs, including but not limited to, reasonable attorney's fees and court costs, such legal expenses to include costs incurred in establishing the indemnification and other rights agreed to in this Paragraph, to persons or property, to the extent caused by the negligence, recklessness, or intentional wrongful misconduct of the CONTRACTOR, its Subcontractors or persons employed or utilized by them in the performance of the Contract. Claims by indemnitees for indemnification shall be limited to the amount of CONTRACTOR's insurance or \$1 million per occurrence, whichever is greater. The parties acknowledge that the amount of the indemnity required hereunder bears a reasonable commercial relationship to the Contract and it is part of the project specifications or the bid documents, if any.

The indemnification obligations under the Contract shall not be restricted in any way by any limitation on the amount or type of damages, compensation, or benefits payable by or for the CONTRACTOR under Workers' Compensation acts, disability benefits acts, or other employee benefits acts, and shall extend to and include any actions brought by or in the name of any employee of the CONTRACTOR or of any third party to whom CONTRACTOR may subcontract a part or all of the Work. This indemnification shall continue beyond the date of completion of the work.

CONTRACTOR: 8350 NW 52nd Terr. Unit 301, Doral, FL 33166 SEAL:
Address

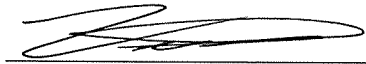
Signature

William Larroche
Print Name

President
Title

DATE: 5/1/2024

EQUAL BENEFITS FOR DOMESTIC PARTNERS AFFIDAVIT

STATE OF Florida)

: SS

COUNTY OF Miami-Dade)

I, the undersigned hereby duly sworn, depose and say that the firm of All in One Fire, INC

provides benefits to domestic partners of its employees on the same basis as it provides benefits to employees' spouses, per City of Key West Code of Ordinances Sec. 2-799.

By: [Signature]

Sworn and subscribed before me this 1 day of May 2024.

NOTARY PUBLIC, State of Florida at Large

My Commission Expires:

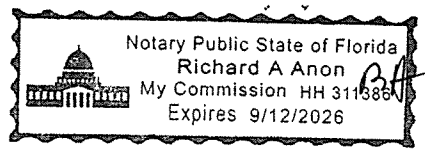

* * * * *

CONE OF SILENCE AFFIDAVIT

STATE OF Florida)

: SS

COUNTY OF Miami-Dade)

I, the undersigned hereby duly sworn, depose and say that all owner(s), partners, officers, directors, employees and agents representing the firm of All in One Fire, INC have read and understand the limitations and procedures regarding communications concerning City of Key West Code of Ordinances Sec. 2-773 Cone of Silence.

By:  _____

Sworn and subscribed before me this

1 day of May 2024.

NOTARY PUBLIC, State of Florida at Large

My Commission Expires: _____

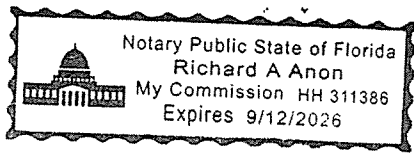

NON-COLLUSION AFFIDAVIT

STATE OF Florida)

: SS

COUNTY OF Miami-Dade

I, the undersigned hereby declares that the only persons or parties interested in this Proposal are those named herein, that this Proposal is, in all respects, fair and without fraud, that it is made without collusion with any official of the Owner, and that the Proposal is made without any connection or collusion with any person submitting another Proposal on this Contract.

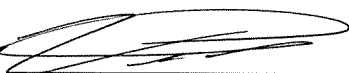
By:  _____

Sworn and subscribed before me this

1 day of May, 2024.

NOTARY PUBLIC, State of Florida at Large

My Commission Expires: _____

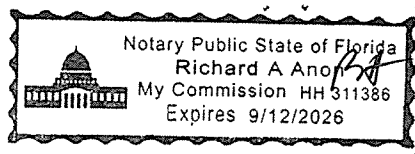

**LOCAL VENDOR CERTIFICATION
PURSUANT TO CITY OF KEY WEST CODE OF ORDINANCES SECTION 2-798**

The undersigned, as a duly authorized representative of the vendor listed herein, certifies to the best of his/her knowledge and belief, that the vendor meets the definition of a "Local Business." For purposes of this section, "local business" shall mean a business which:

- a. Principle address as registered with the FL Department of State located within 30 miles of the boundaries of the city, listed with the chief licensing official as having a business tax receipt with its principle address within 30 miles of the boundaries of the city for at least one year immediately prior to the issuance of the solicitation.
- b. Maintains a workforce of at least 50 percent of its employees from the city or within 30 miles of its boundaries.
- c. Having paid all current license taxes and any other fees due the city at least 24 hours prior to the publication of the call for bids or request for proposals.
 - Not a local vendor pursuant to Code of Ordinances Section 2-798
 - Qualifies as a local vendor pursuant to Code of Ordinances Section 2-798

If you qualify, please complete the following in support of the self-certification & submit copies of your County and City business licenses. Failure to provide the information requested will result in denial of certification as a local business.

Business Name All in One Fire, INC Phone: 305-481-2278

Current Local Address: 8350 NW 52nd Terr, Doral, FL, 33166 Fax:
(P.O Box numbers may not be used to establish status)

Length of time at this address

[Signature] 5/1/2024
Signature of Authorized Representative Date

STATE OF Florida
COUNTY OF Miami-Dade

The foregoing instrument was acknowledged before me this 1 day of MAY, 2024.
By William Larroche, of All in One Fire, INC
(Name of officer or agent, title of officer or agent) Name of corporation acknowledging)
or has produced _____ as identification
(type of identification)

Return Completed form with
Supporting documents to:
City of Key West Purchasing

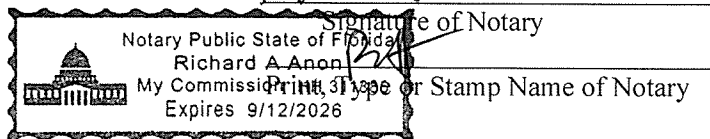

Title or Rank

VENDOR CERTIFICATION REGARDING SCRUTINIZED COMPANIES LISTS

Respondent Vendor Name: <u>All in One Fire, INC</u>
Vendor FEIN: <u>93-2054478</u>
Vendor's Authorized Representative Name and Title: <u>William Larroche, President</u>
Address: <u>8350 NW 52 Terr, Unit 301, Doral, FL 33166</u>
City: <u>Doral</u> State: <u>FL</u> Zip: <u>33166</u>
Phone Number: <u>305-481-2278</u>
Email Address: <u>Junior@allinonefire.com</u>

Section 287.135(2)(a), Florida Statutes, prohibits a company from bidding on, submitting a proposal for, or entering into or renewing a contract for goods or services of any amount if, at the time of contracting or renewal, the company is on the Scrutinized Companies that Boycott Israel List, created pursuant to section 215.4725, Florida Statutes, or is engaged in a boycott of Israel. Section 287.135(2)(b), Florida Statutes, further prohibits a company from bidding on, submitting a proposal for, or entering into or renewing a contract for goods or services over one million dollars (\$1,000,000) if, at the time of contracting or renewal, the company is on either the Scrutinized Companies with Activities in Sudan List or the Scrutinized Companies with Activities in the Iran Petroleum Energy Sector List, both created pursuant to section 215.473, Florida Statutes, or the company is engaged in business operations in Cuba or Syria.

As the person authorized to sign on behalf of Respondent, I hereby certify that the company identified above in the section entitled "Respondent Vendor Name" is not listed on either the Scrutinized Companies that Boycott Israel List, Scrutinized Companies with Activities in Sudan List or the Scrutinized Companies with Activities in the Iran Petroleum Energy Sector List I understand that pursuant to section 287.135, Florida Statutes, the submission of a false certification may subject such company to civil penalties, attorney's fees, and/or costs and termination of the contract at the option of the awarding governmental entity.

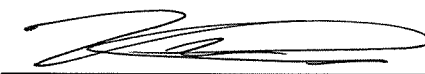
Certified By: <u>William Larroche</u> <u>President</u>
<i>Print Name</i> <i>Print Title</i>
who is authorized to sign on behalf of the above referenced company.
Authorized Signature: 

BIDDER'S CHECKLIST

(Note: The purpose of this checklist is to serve as a reminder of major items to be addressed in submitting a bid and is not intended to be all inclusive. It does not alleviate the Bidder from the responsibility of becoming familiar with all aspects of the Contract Documents and Proper completion and submission of his bid.)

1. All Contract Documents thoroughly read and understood
2. All blank spaces in Bid filled in black ink.
3. Total and unit Prices added correctly.
4. Addenda acknowledged.
5. Subcontractors are named as indicated in the Bid.
6. Experience record included.
7. Bid signed by authorized officer.
9. Bid Bond completed and executed, including power-of-attorney, dated the same date as Bid Bond.
10. Bidder familiar with federal, state, and local laws, ordinances, rules and regulations affecting performance of the work.
11. Bidder, if successful, able to obtain and/or demonstrate possession of required licenses and certificates within (10) ten days after receiving a Notice of Award.
12. Bid submitted intact with the volume containing the Bidding Requirements, Contract Forms and Conditions of the Contract, one (1) original, two (2) USB drives.
13. Bid Documents submitted in sealed envelope and addressed and labeled in conformance with the instructions in the Invitation to Bid.
14. Anti-kickback Affidavit; Public Entity Crime Form; City of Key West Indemnification Equal Benefits for Domestic Partners Affidavit; Local Vendor Certification; Non-Collusion Affidavit; Scrutinized Companies List Certification; Proof of Required Insurance

* * * * *

CITY OF KEY WEST, FLORIDA

Business Tax Receipt

This Document is a business tax receipt
Holder must meet all City zoning and use provisions.
P.O. Box 1409, Key West, Florida 33040 (305) 809-3955

Business Name ALL IN ONE FIRE INC
Location Addr 8350 NW 52ND TERRACE SUITE 301
Lic NBR/Class LIC2024-000292 CONTRACTOR STATE LICENSED NON DBPR
Issued Date 4/26/2024 **Expiration Date: September 30, 2024**

FIRE SPRINKLERS

Comments: CONTRACTOR II - FIRE SPRINKLERS

Restrictions: FL DIV OF ST FIRE MARSHALL #FPC23-000085 (6/30/24)

ALL IN ONE FIRE INC
WILLIAM LARROCHE
8350 NW 52ND TERRACE, SUITE 301
DORAL, FL 33166

This document must be prominently displayed.

ALL IN ONE FIRE INC



CERTIFICATE OF LIABILITY INSURANCE

DATE (MM/DD/YYYY)
04/23/2024

THIS CERTIFICATE IS ISSUED AS A MATTER OF INFORMATION ONLY AND CONFERS NO RIGHTS UPON THE CERTIFICATE HOLDER. THIS CERTIFICATE DOES NOT AFFIRMATIVELY OR NEGATIVELY AMEND, EXTEND OR ALTER THE COVERAGE AFFORDED BY THE POLICIES BELOW. THIS CERTIFICATE OF INSURANCE DOES NOT CONSTITUTE A CONTRACT BETWEEN THE ISSUING INSURER(S), AUTHORIZED REPRESENTATIVE OR PRODUCER, AND THE CERTIFICATE HOLDER.

IMPORTANT: If the certificate holder is an ADDITIONAL INSURED, the policy(ies) must have ADDITIONAL INSURED provisions or be endorsed. If SUBROGATION IS WAIVED, subject to the terms and conditions of the policy, certain policies may require an endorsement. A statement on this certificate does not confer rights to the certificate holder in lieu of such endorsement(s).

PRODUCER Acisure Southeast - Frank H Furman 1314 East Atlantic Blvd. P. O. Box 1927 Pompano Beach FL 33061	CONTACT NAME: Jennifer Martin PHONE (A/C, No, Ext): (954) 943-5050 FAX (A/C, No): (954) 942-6310 E-MAIL ADDRESS: jennifermartin@acisure.com	
INSURED All In One Fire Inc 8350 NW 52nd Terr Suite 301 Doral FL 33166	INSURER(S) AFFORDING COVERAGE	NAIC #
	INSURER A: Hudson Excess Insurance Company	14484
	INSURER B: Infinity Assurance Insurance Company	39497
	INSURER C: Bridgefield Casualty Ins Co	10335
	INSURER D:	
	INSURER E:	

COVERAGES **CERTIFICATE NUMBER:** 24 Auto, 23 GL & WC **REVISION NUMBER:**

THIS IS TO CERTIFY THAT THE POLICIES OF INSURANCE LISTED BELOW HAVE BEEN ISSUED TO THE INSURED NAMED ABOVE FOR THE POLICY PERIOD INDICATED. NOTWITHSTANDING ANY REQUIREMENT, TERM OR CONDITION OF ANY CONTRACT OR OTHER DOCUMENT WITH RESPECT TO WHICH THIS CERTIFICATE MAY BE ISSUED OR MAY PERTAIN, THE INSURANCE AFFORDED BY THE POLICIES DESCRIBED HEREIN IS SUBJECT TO ALL THE TERMS, EXCLUSIONS AND CONDITIONS OF SUCH POLICIES. LIMITS SHOWN MAY HAVE BEEN REDUCED BY PAID CLAIMS.

INSR LTR	TYPE OF INSURANCE	ADDL INSD	SUBR WVD	POLICY NUMBER	POLICY EFF (MM/DD/YYYY)	POLICY EXP (MM/DD/YYYY)	LIMITS
A	<input checked="" type="checkbox"/> COMMERCIAL GENERAL LIABILITY <input type="checkbox"/> CLAIMS-MADE <input checked="" type="checkbox"/> OCCUR <input checked="" type="checkbox"/> Contractual Liability <input checked="" type="checkbox"/> Professional Liability GEN'L AGGREGATE LIMIT APPLIES PER: <input type="checkbox"/> POLICY <input checked="" type="checkbox"/> PRO-JECT <input type="checkbox"/> LOC OTHER:			FSL00116501	07/06/2023	07/06/2024	EACH OCCURRENCE \$ 1,000,000 DAMAGE TO RENTED PREMISES (Ea occurrence) \$ 100,000 MED EXP (Any one person) \$ 5,000 PERSONAL & ADV INJURY \$ 1,000,000 GENERAL AGGREGATE \$ 2,000,000 PRODUCTS - COMP/OP AGG \$ 2,000,000
B	AUTOMOBILE LIABILITY <input type="checkbox"/> ANY AUTO <input type="checkbox"/> OWNED AUTOS ONLY <input checked="" type="checkbox"/> SCHEDULED AUTOS <input type="checkbox"/> HIRED AUTOS ONLY <input type="checkbox"/> NON-OWNED AUTOS ONLY			50004239801	03/14/2024	09/14/2024	COMBINED SINGLE LIMIT (Ea accident) \$ 1,000,000 BODILY INJURY (Per person) \$ BODILY INJURY (Per accident) \$ PROPERTY DAMAGE (Per accident) \$ PIP-Basic \$ 10,000
A	<input checked="" type="checkbox"/> UMBRELLA LIAB <input checked="" type="checkbox"/> OCCUR <input type="checkbox"/> EXCESS LIAB <input type="checkbox"/> CLAIMS-MADE <input type="checkbox"/> DED <input checked="" type="checkbox"/> RETENTION \$ 10,000			FSLU00065001	09/08/2023	07/06/2024	EACH OCCURRENCE \$ 3,000,000 AGGREGATE \$ 3,000,000
C	WORKERS COMPENSATION AND EMPLOYERS' LIABILITY ANY PROPRIETOR/PARTNER/EXECUTIVE OFFICER/MEMBER EXCLUDED? (Mandatory in NH) If yes, describe under DESCRIPTION OF OPERATIONS below Y/N <input checked="" type="checkbox"/> Y N/A			196-58733	08/28/2023	08/28/2024	<input checked="" type="checkbox"/> PER STATUTE <input type="checkbox"/> OTH-ER E.L. EACH ACCIDENT \$ 500,000 E.L. DISEASE - EA EMPLOYEE \$ 500,000 E.L. DISEASE - POLICY LIMIT \$ 500,000

DESCRIPTION OF OPERATIONS / LOCATIONS / VEHICLES (ACORD 101, Additional Remarks Schedule, may be attached if more space is required)

CERTIFICATE HOLDER**CANCELLATION**

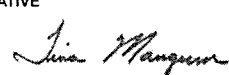
The City of Key West 1300 White Street Key West FL 33040	SHOULD ANY OF THE ABOVE DESCRIBED POLICIES BE CANCELLED BEFORE THE EXPIRATION DATE THEREOF, NOTICE WILL BE DELIVERED IN ACCORDANCE WITH THE POLICY PROVISIONS. AUTHORIZED REPRESENTATIVE 
--	--

© 1988-2015 ACORD CORPORATION. All rights reserved.

Jimmy Patronis
CHIEF FINANCIAL OFFICER
JoAnne Rice
DIVISION DIRECTOR



BUREAU CHIEF
Catherine Thrasher
SAFETY PROGRAM MANAGER

FLORIDA DEPARTMENT OF FINANCIAL SERVICES
DIVISION OF STATE FIRE MARSHAL
200 EAST GAINES STREET - Tallahassee, Florida 32399-0342
Tel. 850-413-3644

CERTIFICATE OF COMPETENCY
OFFICIAL COPY

THIS CERTIFIES THAT: William L Larroche
8350 NW 52nd Terrace, Suite 301
Doral FL 33166

BUSINESS ORGANIZATION: All In One Fire, Inc.

Contractor II is limited to the execution of contracts requiring the ability to layout, fabricate, install, inspect, alter, repair, and service water sprinkler systems, water spray systems, foam-water sprinkler systems, foam-water spray systems, standpipes, combination standpipes and sprinkler risers, all piping that is an integral part of the system beginning at the point of service, sprinkler tank heaters, air lines, thermal systems used in connection with sprinklers, and tanks and pumps connected thereto, excluding pre-engineered systems.

Issue Date: 07/11/2023
Type: 07
Class: 12
County: Miami-Dade
License/Permit #: FPC23-000085
Expiration Date: 06/30/2024



Jimmy Patronis
Chief Financial Officer

Request for Taxpayer Identification Number and Certification

Give Form to the requester. Do not send to the IRS.

► Go to www.irs.gov/FormW9 for instructions and the latest information.

1 Name (as shown on your income tax return). Name is required on this line; do not leave this line blank.

All In One Fire, Inc.

3 Check appropriate box for federal tax classification of the person whose name is entered on line 1. Check only **one** of the following seven boxes.

Individual/sole proprietor or single-member LLC C Corporation S Corporation Partnership Trust/estate

Limited liability company. Enter the tax classification (C=C corporation, S=S corporation, P=Partnership) ► _____

Note: Check the appropriate box in the line above for the tax classification of the single-member owner. Do not check LLC if the LLC is classified as a single-member LLC that is disregarded from the owner unless the owner of the LLC is another LLC that is **not** disregarded from the owner for U.S. federal tax purposes. Otherwise, a single-member LLC that is disregarded from the owner should check the appropriate box for the tax classification of its owner.

Other (see instructions) ►

4 Exemptions (codes apply only to certain entities, not individuals; see instructions on page 3):

Exempt payee code (if any) _____

Exemption from FATCA reporting code (if any) _____

(Applies to accounts maintained outside the U.S.)

5 Address (number, street, and apt. or suite no.) See instructions.

8350 NW 52nd Terr Unit 301

Requester's name and address (optional)

6 City, state, and ZIP code

Doral, FL 33166

7 List account number(s) here (optional)

Part I Taxpayer Identification Number (TIN)

Enter your TIN in the appropriate box. The TIN provided must match the name given on line 1 to avoid backup withholding. For individuals, this is generally your social security number (SSN). However, for a resident alien, sole proprietor, or disregarded entity, see the instructions for Part I, later. For other entities, it is your employer identification number (EIN). If you do not have a number, see *How to get a TIN*, later.

Note: If the account is in more than one name, see the instructions for line 1. Also see *What Name and Number To Give the Requester* for guidelines on whose number to enter.

Social security number								
			-					

or

Employer identification number									
9	3	-	2	0	5	4	4	7	8

Part II Certification

Under penalties of perjury, I certify that:

- The number shown on this form is my correct taxpayer identification number (or I am waiting for a number to be issued to me); and
- I am not subject to backup withholding because: (a) I am exempt from backup withholding, or (b) I have not been notified by the Internal Revenue Service (IRS) that I am subject to backup withholding as a result of a failure to report all interest or dividends, or (c) the IRS has notified me that I am no longer subject to backup withholding; and
- I am a U.S. citizen or other U.S. person (defined below); and
- The FATCA code(s) entered on this form (if any) indicating that I am exempt from FATCA reporting is correct.

Certification instructions. You must cross out item 2 above if you have been notified by the IRS that you are currently subject to backup withholding because you have failed to report all interest and dividends on your tax return. For real estate transactions, item 2 does not apply. For mortgage interest paid, acquisition or abandonment of secured property, cancellation of debt, contributions to an individual retirement arrangement (IRA), and generally, payments other than interest and dividends, you are not required to sign the certification, but you must provide your correct TIN. See the instructions for Part II, later.

Sign Here

Signature of U.S. person ► *William Larroche*

Date ► 01/08/2024

General Instructions

Section references are to the Internal Revenue Code unless otherwise noted.

Future developments. For the latest information about developments related to Form W-9 and its instructions, such as legislation enacted after they were published, go to www.irs.gov/FormW9.

Purpose of Form

An individual or entity (Form W-9 requester) who is required to file an information return with the IRS must obtain your correct taxpayer identification number (TIN) which may be your social security number (SSN), individual taxpayer identification number (ITIN), adoption taxpayer identification number (ATIN), or employer identification number (EIN), to report on an information return the amount paid to you, or other amount reportable on an information return. Examples of information returns include, but are not limited to, the following.

- Form 1099-INT (interest earned or paid)

- Form 1099-DIV (dividends, including those from stocks or mutual funds)
- Form 1099-MISC (various types of income, prizes, awards, or gross proceeds)
- Form 1099-B (stock or mutual fund sales and certain other transactions by brokers)
- Form 1099-S (proceeds from real estate transactions)
- Form 1099-K (merchant card and third party network transactions)
- Form 1098 (home mortgage interest), 1098-E (student loan interest), 1098-T (tuition)
- Form 1099-C (canceled debt)
- Form 1099-A (acquisition or abandonment of secured property)

Use Form W-9 only if you are a U.S. person (including a resident alien), to provide your correct TIN.

If you do not return Form W-9 to the requester with a TIN, you might be subject to backup withholding. See What is backup withholding, later.

By signing the filled-out form, you:

1. Certify that the TIN you are giving is correct (or you are waiting for a number to be issued),
2. Certify that you are not subject to backup withholding, or
3. Claim exemption from backup withholding if you are a U.S. exempt payee. If applicable, you are also certifying that as a U.S. person, your allocable share of any partnership income from a U.S. trade or business is not subject to the withholding tax on foreign partners' share of effectively connected income, and
4. Certify that FATCA code(s) entered on this form (if any) indicating that you are exempt from the FATCA reporting, is correct. See *What is FATCA reporting*, later, for further information.

Note: If you are a U.S. person and a requester gives you a form other than Form W-9 to request your TIN, you must use the requester's form if it is substantially similar to this Form W-9.

Definition of a U.S. person. For federal tax purposes, you are considered a U.S. person if you are:

- An individual who is a U.S. citizen or U.S. resident alien;
- A partnership, corporation, company, or association created or organized in the United States or under the laws of the United States;
- An estate (other than a foreign estate); or
- A domestic trust (as defined in Regulations section 301.7701-7).

Special rules for partnerships. Partnerships that conduct a trade or business in the United States are generally required to pay a withholding tax under section 1446 on any foreign partners' share of effectively connected taxable income from such business. Further, in certain cases where a Form W-9 has not been received, the rules under section 1446 require a partnership to presume that a partner is a foreign person, and pay the section 1446 withholding tax. Therefore, if you are a U.S. person that is a partner in a partnership conducting a trade or business in the United States, provide Form W-9 to the partnership to establish your U.S. status and avoid section 1446 withholding on your share of partnership income.

In the cases below, the following person must give Form W-9 to the partnership for purposes of establishing its U.S. status and avoiding withholding on its allocable share of net income from the partnership conducting a trade or business in the United States.

- In the case of a disregarded entity with a U.S. owner, the U.S. owner of the disregarded entity and not the entity;
- In the case of a grantor trust with a U.S. grantor or other U.S. owner, generally, the U.S. grantor or other U.S. owner of the grantor trust and not the trust; and
- In the case of a U.S. trust (other than a grantor trust), the U.S. trust (other than a grantor trust) and not the beneficiaries of the trust.

Foreign person. If you are a foreign person or the U.S. branch of a foreign bank that has elected to be treated as a U.S. person, do not use Form W-9. Instead, use the appropriate Form W-8 or Form 8233 (see Pub. 515, Withholding of Tax on Nonresident Aliens and Foreign Entities).

Nonresident alien who becomes a resident alien. Generally, only a nonresident alien individual may use the terms of a tax treaty to reduce or eliminate U.S. tax on certain types of income. However, most tax treaties contain a provision known as a "saving clause." Exceptions specified in the saving clause may permit an exemption from tax to continue for certain types of income even after the payee has otherwise become a U.S. resident alien for tax purposes.

If you are a U.S. resident alien who is relying on an exception contained in the saving clause of a tax treaty to claim an exemption from U.S. tax on certain types of income, you must attach a statement to Form W-9 that specifies the following five items.

1. The treaty country. Generally, this must be the same treaty under which you claimed exemption from tax as a nonresident alien.
2. The treaty article addressing the income.
3. The article number (or location) in the tax treaty that contains the saving clause and its exceptions.
4. The type and amount of income that qualifies for the exemption from tax.
5. Sufficient facts to justify the exemption from tax under the terms of the treaty article.

Example. Article 20 of the U.S.-China income tax treaty allows an exemption from tax for scholarship income received by a Chinese student temporarily present in the United States. Under U.S. law, this student will become a resident alien for tax purposes if his or her stay in the United States exceeds 5 calendar years. However, paragraph 2 of the first Protocol to the U.S.-China treaty (dated April 30, 1984) allows the provisions of Article 20 to continue to apply even after the Chinese student becomes a resident alien of the United States. A Chinese student who qualifies for this exception (under paragraph 2 of the first protocol) and is relying on this exception to claim an exemption from tax on his or her scholarship or fellowship income would attach to Form W-9 a statement that includes the information described above to support that exemption.

If you are a nonresident alien or a foreign entity, give the requester the appropriate completed Form W-8 or Form 8233.

Backup Withholding

What is backup withholding? Persons making certain payments to you must under certain conditions withhold and pay to the IRS 24% of such payments. This is called "backup withholding." Payments that may be subject to backup withholding include interest, tax-exempt interest, dividends, broker and barter exchange transactions, rents, royalties, nonemployee pay, payments made in settlement of payment card and third party network transactions, and certain payments from fishing boat operators. Real estate transactions are not subject to backup withholding.

You will not be subject to backup withholding on payments you receive if you give the requester your correct TIN, make the proper certifications, and report all your taxable interest and dividends on your tax return.

Payments you receive will be subject to backup withholding if:

1. You do not furnish your TIN to the requester,
2. You do not certify your TIN when required (see the instructions for Part II for details),
3. The IRS tells the requester that you furnished an incorrect TIN,
4. The IRS tells you that you are subject to backup withholding because you did not report all your interest and dividends on your tax return (for reportable interest and dividends only), or
5. You do not certify to the requester that you are not subject to backup withholding under 4 above (for reportable interest and dividend accounts opened after 1983 only).

Certain payees and payments are exempt from backup withholding. See *Exempt payee code*, later, and the separate Instructions for the Requester of Form W-9 for more information.

Also see *Special rules for partnerships*, earlier.

What is FATCA Reporting?

The Foreign Account Tax Compliance Act (FATCA) requires a participating foreign financial institution to report all United States account holders that are specified United States persons. Certain payees are exempt from FATCA reporting. See *Exemption from FATCA reporting code*, later, and the Instructions for the Requester of Form W-9 for more information.

Updating Your Information

You must provide updated information to any person to whom you claimed to be an exempt payee if you are no longer an exempt payee and anticipate receiving reportable payments in the future from this person. For example, you may need to provide updated information if you are a C corporation that elects to be an S corporation, or if you no longer are tax exempt. In addition, you must furnish a new Form W-9 if the name or TIN changes for the account; for example, if the grantor of a grantor trust dies.

Penalties

Failure to furnish TIN. If you fail to furnish your correct TIN to a requester, you are subject to a penalty of \$50 for each such failure unless your failure is due to reasonable cause and not to willful neglect.

Civil penalty for false information with respect to withholding. If you make a false statement with no reasonable basis that results in no backup withholding, you are subject to a \$500 penalty.

Criminal penalty for falsifying information. Willfully falsifying certifications or affirmations may subject you to criminal penalties including fines and/or imprisonment.

Misuse of TINs. If the requester discloses or uses TINs in violation of federal law, the requester may be subject to civil and criminal penalties.

Specific Instructions

Line 1

You must enter one of the following on this line; **do not** leave this line blank. The name should match the name on your tax return.

If this Form W-9 is for a joint account (other than an account maintained by a foreign financial institution (FFI)), list first, and then circle, the name of the person or entity whose number you entered in Part I of Form W-9. If you are providing Form W-9 to an FFI to document a joint account, each holder of the account that is a U.S. person must provide a Form W-9.

a. **Individual.** Generally, enter the name shown on your tax return. If you have changed your last name without informing the Social Security Administration (SSA) of the name change, enter your first name, the last name as shown on your social security card, and your new last name.

Note: ITIN applicant: Enter your individual name as it was entered on your Form W-7 application, line 1a. This should also be the same as the name you entered on the Form 1040/1040A/1040EZ you filed with your application.

b. **Sole proprietor or single-member LLC.** Enter your individual name as shown on your 1040/1040A/1040EZ on line 1. You may enter your business, trade, or “doing business as” (DBA) name on line 2.

c. **Partnership, LLC that is not a single-member LLC, C corporation, or S corporation.** Enter the entity’s name as shown on the entity’s tax return on line 1 and any business, trade, or DBA name on line 2.

d. **Other entities.** Enter your name as shown on required U.S. federal tax documents on line 1. This name should match the name shown on the charter or other legal document creating the entity. You may enter any business, trade, or DBA name on line 2.

e. **Disregarded entity.** For U.S. federal tax purposes, an entity that is disregarded as an entity separate from its owner is treated as a “disregarded entity.” See Regulations section 301.7701-2(c)(2)(iii). Enter the owner’s name on line 1. The name of the entity entered on line 1 should never be a disregarded entity. The name on line 1 should be the name shown on the income tax return on which the income should be reported. For example, if a foreign LLC that is treated as a disregarded entity for U.S. federal tax purposes has a single owner that is a U.S. person, the U.S. owner’s name is required to be provided on line 1. If the direct owner of the entity is also a disregarded entity, enter the first owner that is not disregarded for federal tax purposes. Enter the disregarded entity’s name on line 2, “Business name/disregarded entity name.” If the owner of the disregarded entity is a foreign person, the owner must complete an appropriate Form W-8 instead of a Form W-9. This is the case even if the foreign person has a U.S. TIN.

Line 2

If you have a business name, trade name, DBA name, or disregarded entity name, you may enter it on line 2.

Line 3

Check the appropriate box on line 3 for the U.S. federal tax classification of the person whose name is entered on line 1. Check only one box on line 3.

IF the entity/person on line 1 is a(n) . . .	THEN check the box for . . .
• Corporation	Corporation
• Individual • Sole proprietorship, or • Single-member limited liability company (LLC) owned by an individual and disregarded for U.S. federal tax purposes.	Individual/sole proprietor or single-member LLC
• LLC treated as a partnership for U.S. federal tax purposes, • LLC that has filed Form 8832 or 2553 to be taxed as a corporation, or • LLC that is disregarded as an entity separate from its owner but the owner is another LLC that is not disregarded for U.S. federal tax purposes.	Limited liability company and enter the appropriate tax classification. (P= Partnership; C= C corporation; or S= S corporation)
• Partnership	Partnership
• Trust/estate	Trust/estate

Line 4, Exemptions

If you are exempt from backup withholding and/or FATCA reporting, enter in the appropriate space on line 4 any code(s) that may apply to you.

Exempt payee code.

- Generally, individuals (including sole proprietors) are not exempt from backup withholding.
- Except as provided below, corporations are exempt from backup withholding for certain payments, including interest and dividends.
- Corporations are not exempt from backup withholding for payments made in settlement of payment card or third party network transactions.
- Corporations are not exempt from backup withholding with respect to attorneys’ fees or gross proceeds paid to attorneys, and corporations that provide medical or health care services are not exempt with respect to payments reportable on Form 1099-MISC.

The following codes identify payees that are exempt from backup withholding. Enter the appropriate code in the space in line 4.

- 1—An organization exempt from tax under section 501(a), any IRA, or a custodial account under section 403(b)(7) if the account satisfies the requirements of section 401(f)(2)
- 2—The United States or any of its agencies or instrumentalities
- 3—A state, the District of Columbia, a U.S. commonwealth or possession, or any of their political subdivisions or instrumentalities
- 4—A foreign government or any of its political subdivisions, agencies, or instrumentalities
- 5—A corporation
- 6—A dealer in securities or commodities required to register in the United States, the District of Columbia, or a U.S. commonwealth or possession
- 7—A futures commission merchant registered with the Commodity Futures Trading Commission
- 8—A real estate investment trust
- 9—An entity registered at all times during the tax year under the Investment Company Act of 1940
- 10—A common trust fund operated by a bank under section 584(a)
- 11—A financial institution
- 12—A middleman known in the investment community as a nominee or custodian
- 13—A trust exempt from tax under section 664 or described in section 4947

The following chart shows types of payments that may be exempt from backup withholding. The chart applies to the exempt payees listed above, 1 through 13.

IF the payment is for . . .	THEN the payment is exempt for . . .
Interest and dividend payments	All exempt payees except for 7
Broker transactions	Exempt payees 1 through 4 and 6 through 11 and all C corporations. S corporations must not enter an exempt payee code because they are exempt only for sales of noncovered securities acquired prior to 2012.
Barter exchange transactions and patronage dividends	Exempt payees 1 through 4
Payments over \$600 required to be reported and direct sales over \$5,000 ¹	Generally, exempt payees 1 through 5 ²
Payments made in settlement of payment card or third party network transactions	Exempt payees 1 through 4

¹ See Form 1099-MISC, Miscellaneous Income, and its instructions.

² However, the following payments made to a corporation and reportable on Form 1099-MISC are not exempt from backup withholding: medical and health care payments, attorneys' fees, gross proceeds paid to an attorney reportable under section 6045(f), and payments for services paid by a federal executive agency.

Exemption from FATCA reporting code. The following codes identify payees that are exempt from reporting under FATCA. These codes apply to persons submitting this form for accounts maintained outside of the United States by certain foreign financial institutions. Therefore, if you are only submitting this form for an account you hold in the United States, you may leave this field blank. Consult with the person requesting this form if you are uncertain if the financial institution is subject to these requirements. A requester may indicate that a code is not required by providing you with a Form W-9 with "Not Applicable" (or any similar indication) written or printed on the line for a FATCA exemption code.

A—An organization exempt from tax under section 501(a) or any individual retirement plan as defined in section 7701(a)(37)

B—The United States or any of its agencies or instrumentalities

C—A state, the District of Columbia, a U.S. commonwealth or possession, or any of their political subdivisions or instrumentalities

D—A corporation the stock of which is regularly traded on one or more established securities markets, as described in Regulations section 1.1472-1(c)(1)(i)

E—A corporation that is a member of the same expanded affiliated group as a corporation described in Regulations section 1.1472-1(c)(1)(i)

F—A dealer in securities, commodities, or derivative financial instruments (including notional principal contracts, futures, forwards, and options) that is registered as such under the laws of the United States or any state

G—A real estate investment trust

H—A regulated investment company as defined in section 851 or an entity registered at all times during the tax year under the Investment Company Act of 1940

I—A common trust fund as defined in section 584(a)

J—A bank as defined in section 581

K—A broker

L—A trust exempt from tax under section 664 or described in section 4947(a)(1)

M—A tax exempt trust under a section 403(b) plan or section 457(g) plan

Note: You may wish to consult with the financial institution requesting this form to determine whether the FATCA code and/or exempt payee code should be completed.

Line 5

Enter your address (number, street, and apartment or suite number). This is where the requester of this Form W-9 will mail your information returns. If this address differs from the one the requester already has on file, write NEW at the top. If a new address is provided, there is still a chance the old address will be used until the payor changes your address in their records.

Line 6

Enter your city, state, and ZIP code.

Part I. Taxpayer Identification Number (TIN)

Enter your TIN in the appropriate box. If you are a resident alien and you do not have and are not eligible to get an SSN, your TIN is your IRS individual taxpayer identification number (ITIN). Enter it in the social security number box. If you do not have an ITIN, see *How to get a TIN* below.

If you are a sole proprietor and you have an EIN, you may enter either your SSN or EIN.

If you are a single-member LLC that is disregarded as an entity separate from its owner, enter the owner's SSN (or EIN, if the owner has one). Do not enter the disregarded entity's EIN. If the LLC is classified as a corporation or partnership, enter the entity's EIN.

Note: See *What Name and Number To Give the Requester*, later, for further clarification of name and TIN combinations.

How to get a TIN. If you do not have a TIN, apply for one immediately. To apply for an SSN, get Form SS-5, Application for a Social Security Card, from your local SSA office or get this form online at www.SSA.gov. You may also get this form by calling 1-800-772-1213. Use Form W-7, Application for IRS Individual Taxpayer Identification Number, to apply for an ITIN, or Form SS-4, Application for Employer Identification Number, to apply for an EIN. You can apply for an EIN online by accessing the IRS website at www.irs.gov/Businesses and clicking on Employer Identification Number (EIN) under Starting a Business. Go to www.irs.gov/Forms to view, download, or print Form W-7 and/or Form SS-4. Or, you can go to www.irs.gov/OrderForms to place an order and have Form W-7 and/or SS-4 mailed to you within 10 business days.

If you are asked to complete Form W-9 but do not have a TIN, apply for a TIN and write "Applied For" in the space for the TIN, sign and date the form, and give it to the requester. For interest and dividend payments, and certain payments made with respect to readily tradable instruments, generally you will have 60 days to get a TIN and give it to the requester before you are subject to backup withholding on payments. The 60-day rule does not apply to other types of payments. You will be subject to backup withholding on all such payments until you provide your TIN to the requester.

Note: Entering "Applied For" means that you have already applied for a TIN or that you intend to apply for one soon.

Caution: A disregarded U.S. entity that has a foreign owner must use the appropriate Form W-8.

Part II. Certification

To establish to the withholding agent that you are a U.S. person, or resident alien, sign Form W-9. You may be requested to sign by the withholding agent even if item 1, 4, or 5 below indicates otherwise.

For a joint account, only the person whose TIN is shown in Part I should sign (when required). In the case of a disregarded entity, the person identified on line 1 must sign. Exempt payees, see *Exempt payee code*, earlier.

Signature requirements. Complete the certification as indicated in items 1 through 5 below.

1. Interest, dividend, and barter exchange accounts opened before 1984 and broker accounts considered active during 1983. You must give your correct TIN, but you do not have to sign the certification.

2. Interest, dividend, broker, and barter exchange accounts opened after 1983 and broker accounts considered inactive during 1983. You must sign the certification or backup withholding will apply. If you are subject to backup withholding and you are merely providing your correct TIN to the requester, you must cross out item 2 in the certification before signing the form.

3. Real estate transactions. You must sign the certification. You may cross out item 2 of the certification.

4. Other payments. You must give your correct TIN, but you do not have to sign the certification unless you have been notified that you have previously given an incorrect TIN. "Other payments" include payments made in the course of the requester's trade or business for rents, royalties, goods (other than bills for merchandise), medical and health care services (including payments to corporations), payments to a nonemployee for services, payments made in settlement of payment card and third party network transactions, payments to certain fishing boat crew members and fishermen, and gross proceeds paid to attorneys (including payments to corporations).

5. Mortgage interest paid by you, acquisition or abandonment of secured property, cancellation of debt, qualified tuition program payments (under section 529), ABLE accounts (under section 529A), IRA, Coverdell ESA, Archer MSA or HSA contributions or distributions, and pension distributions. You must give your correct TIN, but you do not have to sign the certification.

What Name and Number To Give the Requester

For this type of account:	Give name and SSN of:
1. Individual	The individual
2. Two or more individuals (joint account) other than an account maintained by an FFI	The actual owner of the account or, if combined funds, the first individual on the account ¹
3. Two or more U.S. persons (joint account maintained by an FFI)	Each holder of the account
4. Custodial account of a minor (Uniform Gift to Minors Act)	The minor ²
5. a. The usual revocable savings trust (grantor is also trustee) b. So-called trust account that is not a legal or valid trust under state law	The grantor-trustee ¹ The actual owner ¹
6. Sole proprietorship or disregarded entity owned by an individual	The owner ³
7. Grantor trust filing under Optional Form 1099 Filing Method 1 (see Regulations section 1.671-4(b)(2)(i)(A))	The grantor*
For this type of account:	Give name and EIN of:
8. Disregarded entity not owned by an individual	The owner
9. A valid trust, estate, or pension trust	Legal entity ⁴
10. Corporation or LLC electing corporate status on Form 8832 or Form 2553	The corporation
11. Association, club, religious, charitable, educational, or other tax-exempt organization	The organization
12. Partnership or multi-member LLC	The partnership
13. A broker or registered nominee	The broker or nominee

For this type of account:	Give name and EIN of:
14. Account with the Department of Agriculture in the name of a public entity (such as a state or local government, school district, or prison) that receives agricultural program payments	The public entity
15. Grantor trust filing under the Form 1041 Filing Method or the Optional Form 1099 Filing Method 2 (see Regulations section 1.671-4(b)(2)(i)(B))	The trust

¹ List first and circle the name of the person whose number you furnish. If only one person on a joint account has an SSN, that person's number must be furnished.

² Circle the minor's name and furnish the minor's SSN.

³ You must show your individual name and you may also enter your business or DBA name on the "Business name/disregarded entity" name line. You may use either your SSN or EIN (if you have one), but the IRS encourages you to use your SSN.

⁴ List first and circle the name of the trust, estate, or pension trust. (Do not furnish the TIN of the personal representative or trustee unless the legal entity itself is not designated in the account title.) Also see *Special rules for partnerships*, earlier.

*Note: The grantor also must provide a Form W-9 to trustee of trust.

Note: If no name is circled when more than one name is listed, the number will be considered to be that of the first name listed.

Secure Your Tax Records From Identity Theft

Identity theft occurs when someone uses your personal information such as your name, SSN, or other identifying information, without your permission, to commit fraud or other crimes. An identity thief may use your SSN to get a job or may file a tax return using your SSN to receive a refund.

To reduce your risk:

- Protect your SSN,
- Ensure your employer is protecting your SSN, and
- Be careful when choosing a tax preparer.

If your tax records are affected by identity theft and you receive a notice from the IRS, respond right away to the name and phone number printed on the IRS notice or letter.

If your tax records are not currently affected by identity theft but you think you are at risk due to a lost or stolen purse or wallet, questionable credit card activity or credit report, contact the IRS Identity Theft Hotline at 1-800-908-4490 or submit Form 14039.

For more information, see Pub. 5027, Identity Theft Information for Taxpayers.

Victims of identity theft who are experiencing economic harm or a systemic problem, or are seeking help in resolving tax problems that have not been resolved through normal channels, may be eligible for Taxpayer Advocate Service (TAS) assistance. You can reach TAS by calling the TAS toll-free case intake line at 1-877-777-4778 or TTY/TDD 1-800-829-4059.

Protect yourself from suspicious emails or phishing schemes.

Phishing is the creation and use of email and websites designed to mimic legitimate business emails and websites. The most common act is sending an email to a user falsely claiming to be an established legitimate enterprise in an attempt to scam the user into surrendering private information that will be used for identity theft.

The IRS does not initiate contacts with taxpayers via emails. Also, the IRS does not request personal detailed information through email or ask taxpayers for the PIN numbers, passwords, or similar secret access information for their credit card, bank, or other financial accounts.

If you receive an unsolicited email claiming to be from the IRS, forward this message to phishing@irs.gov. You may also report misuse of the IRS name, logo, or other IRS property to the Treasury Inspector General for Tax Administration (TIGTA) at 1-800-366-4484. You can forward suspicious emails to the Federal Trade Commission at spam@uce.gov or report them at www.ftc.gov/complaint. You can contact the FTC at www.ftc.gov/idtheft or 877-IDTHEFT (877-438-4338). If you have been the victim of identity theft, see www.IdentityTheft.gov and Pub. 5027.

Visit www.irs.gov/IdentityTheft to learn more about identity theft and how to reduce your risk.

Privacy Act Notice

Section 6109 of the Internal Revenue Code requires you to provide your correct TIN to persons (including federal agencies) who are required to file information returns with the IRS to report interest, dividends, or certain other income paid to you; mortgage interest you paid; the acquisition or abandonment of secured property; the cancellation of debt; or contributions you made to an IRA, Archer MSA, or HSA. The person collecting this form uses the information on the form to file information returns with the IRS, reporting the above information. Routine uses of this information include giving it to the Department of Justice for civil and criminal litigation and to cities, states, the District of Columbia, and U.S. commonwealths and possessions for use in administering their laws. The information also may be disclosed to other countries under a treaty, to federal and state agencies to enforce civil and criminal laws, or to federal law enforcement and intelligence agencies to combat terrorism. You must provide your TIN whether or not you are required to file a tax return. Under section 3406, payers must generally withhold a percentage of taxable interest, dividend, and certain other payments to a payee who does not give a TIN to the payer. Certain penalties may also apply for providing false or fraudulent information.

SECTION 01001
GENERAL REQUIREMENTS

1. PROJECT DESCRIPTION

1.1 GENERAL

- A. The following information though not all-inclusive, is given to assist Contractors in the evaluation of the work required to meet the project objectives.
- B. A brief description of the work is stated in the Invitation to Bid. To determine the full scope of the project or of any particular part of the project, coordinate the applicable information in the several parts of these Contract Documents.

2. SEQUENCE OF OPERATIONS

2.1 MOBILIZATION AND DEMOBILIZATION

- A. Contractor shall be responsible for mobilization and demobilization of labor, materials and equipment. Payment for mobilization and demobilization will be included in the unit price indicated in the BID.

B. DAILY REPORTS

- 1) The CONTRACTOR shall submit daily reports of construction activities for each site, including non-work days. The report shall include:
 - a) Manpower, number of men by craft
 - b) Quality Control
 - c) Equipment on the Project;
 - d) Major deliveries
 - e) Activities worked with reference to the CPM schedule activity numbers
 - f) New problems
 - g) Other pertinent information
- 2) A similar report shall be submitted for/by each Subcontractor.
- 3) The reports shall be submitted to the ENGINEER each month.

2.2 SCHEDULING

- A. Plan the work and carry it out with minimum interference to the operation of the existing facilities. Prior to starting the work, confer with the Engineer and Owner's representative to develop an approved work schedule, which will permit the facilities to function as normally as practical. It may be necessary to do certain parts of the work outside normal working hours in order to avoid undesirable conditions. The Contractor shall do this work at such times and at no additional cost to the Owner.

2.3 COORDINATION

- A. Contractors shall cooperate in the coordination of their separate activities in a manner that will provide the least interference with the Owner's operations and other contractors and

utility companies working in the area, and in the interfacing and connection of the separate elements of the overall project work.

- B. If any difficulty or dispute should arise in the accomplishment of the above, the problem shall be brought immediately to the attention of the Engineer.

2.4 WORK TO BE PERFORMED BY OTHERS

- A. During the construction period for this project, the Owner (either with his own forces or under a separate contract) may be performing work that may require the cooperation of the Contractors in scheduling and coordination to avoid conflicts.
- B. If any difficulty or dispute should arise in the accomplishment of the above, the problem shall be brought immediately to the attention of the Engineer.
- C. All Contractors working on this site are subject to this requirement for cooperation, and all shall abide by the Engineer's decision in resolving project coordination problems without additional cost to the Owner.

3. SITE CONDITIONS

3.1 SITE INVESTIGATION AND REPRESENTATION

- A. The Contractor acknowledges satisfaction as to the nature and location of the work, the general and local conditions, particularly those bearing upon availability of transportation, access to the site, disposal, handling and storage of materials, availability of labor, water, electric power, roads, and uncertainties of weather, or similar physical conditions at the site, the conformation and conditions of the ground, the character of equipment and facilities needed preliminary to and during the prosecution of the work, and all other matters which can any way affect the work or the cost thereof under this Contract.
- B. The Contractor further acknowledges satisfaction as to character, quality, and quantity of surface and subsurface materials to be encountered from his inspection of the site and from reviewing any available records of exploratory work furnished by the Owner or included in these Documents. Failure by the Contractor to become acquainted with the physical conditions of the site and all available information will not relieve the Contractor from responsibility for properly estimating the difficulty or cost of successfully performing the work.
- C. The Contractor warrants that as a result of examination and investigation of all the aforesaid data, the contractor can perform the work in a good and workmanlike manner and to the satisfaction of the Owner.
- D. The Owner assumes no responsibility for any representations made by any of its officers or agents during or prior to the execution of this Contract, unless (1) such representations are expressly stated in the Contract, and (2) the Contract expressly provides that the responsibility therefore is assumed by the Owner.

3.2 INFORMATION ON SITE CONDITIONS

- A. General: Any information obtained by the Engineer regarding site conditions, subsurface information, water level, existing construction of site facilities as applicable, and similar data will be available for inspection at the office of the Engineer upon request. Such information is offered as supplementary information only. Neither the Engineer nor the Owner assumes any responsibility for the completeness or interpretation of such supplementary information.

3.3 DIFFERING SUBSURFACE CONDITIONS

- A. The Engineer shall investigate such conditions promptly and following this investigation, the Contractor shall proceed with the work, unless otherwise instructed by the Engineer. If the Engineer finds that such conditions do so materially differ and cause an increase or decrease in the cost of, or in the time required for performing the work, the Engineer will recommend to the Owner the amount of adjustment in cost and time he considers reasonable. The Owner will make the final decision on all Change Orders to the Contract regarding any adjustment in cost or time for completion.

3.4 UTILITIES

- A. During any excavation the Contractor shall be responsible for determining, at his cost, the locations of all known utilities in the project area.
- B. Contractor shall notify utility location service (e.g. Call Sunshine 1-800-432-4770) a minimum for 48 hours prior to work order mobilization. Assigned notification number shall be maintained at the job site at all times and recorded in the daily reports.

3.5 CONTRACTOR'S RESPONSIBILITY FOR UTILITY PROPERTIES AND SERVICE

- A. Where the Contractor's operations could cause damage or inconvenience to telephone, television, gas, water, sewer, or irrigation systems, the operations shall be suspended until all arrangements necessary for the protection of these utilities and services have been made by the Contractor.
- B. Notify all utility offices, which are affected by the construction operation at least 48 hours in advance. Under no circumstances expose any utility without first obtaining permission from the appropriate agency. Once permission has been granted, locate, expose, and provide temporary support for all existing underground utilities.
- C. The Contractor shall be solely and directly responsible to the Owner and operators of such properties for any damage, injury, expense, loss, inconvenience, delay, suits, actions, or claims of any character brought because of any injuries or damage which may result from the construction operations under this Contract.
- D. Neither the Owner nor its Officers or agents shall be responsible to the Contractor for damages as a result of the Contractor's failure to protect utilities encountered in the work.

- E. In the event of interruption to domestic water, sewer, storm drain, or other utility services as a result of accidental breakage due to construction operations, promptly notify the proper authority. Cooperate with said authority in restoration of service as promptly as possible and bear all costs of repair. In no case shall interruption of any water or utility service be allowed to exist outside working hours unless prior approval is granted.
- F. In the event the Contractor encounters water service lines that interfere with trenching, he may, by obtaining prior approval of the property owner, Water Department, or Fire Department as applicable, and the Engineer, cut the service dig through, and restore service with similar and equal materials at the Contractor's expense.
- G. The Contractor shall replace, at his own expense, all existing utilities or structures removed or damaged during construction, unless otherwise provided for in these Contract Documents or ordered by the Engineer.

4. TEMPORARY CONSTRUCTION UTILITIES AND FACILITIES

4.1 TEMPORARY WATER

- A. The Contractor shall make his own arrangements to obtain suitable water for any need and shall pay all costs.

4.2 TEMPORARY ELECTRIC POWER

- A. The Contractor shall make his own arrangements to obtain and pay for electrical power used until final acceptance by the Owner.

4.3 SAFETY REQUIREMENTS FOR TEMPORARY ELECTRIC POWER

- A. Temporary electric power installation shall meet the construction Safety requirements of OSHA, State, and other governing agencies.

4.4 SANITARY FACILITIES

- A. The Contractor shall provide and maintain sanitary facilities for his employees and his subcontractor's employees that will comply with the regulations of the local and State Departments of Health and as directed by the Owner.

4.5 STORAGE OF MATERIALS

- A. Materials shall be so stored as to ensure the preservation of their quality and fitness for the work. When considered necessary, they shall be placed on wooden platforms or other clean hard surfaces and not on the ground. Stored materials shall be located so as to facilitate prompt inspection. Stored materials in the right-of-way shall be fully barricaded, with bottom height of 47" or lower and top height of 36" min., also they must be fitted and should have lights at night. Private property shall not be used for storage purposes without the written permission of the owner or lessee. Materials shall not be stored where access to any structure, plot, or road is blocked. Any material the Contractor

wishes to store on the site must be approved by the Engineer or his designee, and must be stored at the location designated by him.

- B. Delicate instruments and materials subject to vandalism shall be placed under lock cover and, if necessary, provided with temperature control as recommended by the manufacturer.

5. SAFETY AND CONVENIENCE

5.1 CONSTRUCTION SAFETY PROGRAM

- A. The Contractor shall develop and maintain for the duration of this Contract, a safety program that will effectively incorporate and implement all required safety provisions. The Contractor shall appoint an employee who is qualified and authorized to supervise and enforce compliance with the safety program.
- B. The duty of the Engineer to conduct construction review of the Contractor's performance is not intended to include a review or approval of the adequacy of the Contractor's safety supervisor, the safety program or any safety measures taken in, on, or near the construction site.
- C. The Contractor shall do all work necessary to protect the general public from hazards, including, but not limited to, surface irregularities, or unramped grade changes in pedestrian sidewalk or roadway. Barricades, lights, and proper signs shall be furnished in sufficient amount to safeguard the public and the work.
- D. The performance of all work and all completed construction, particularly with respect to ladders, platforms, structure openings, scaffolding, shoring, lagging, machinery guards and the like, shall be in accordance with the applicable governing safety authorities.
- E. During construction, the Contractor shall construct and at all times maintain satisfactory and substantial temporary chain link fencing, solid fencing, railing, barricades or steel plates, as applicable, at all openings, obstructions, or other hazards in streets, sidewalks, floors, roofs, and walkways. All such barriers shall have adequate warning lights as necessary, or required for safety. Also all barriers shall have a lower horizontal continuous frame member at a maximum of 17" above grade.

5.2 ACCIDENT REPORTS

- A. If death or serious injuries or serious damages are caused; the Contractor must promptly report by telephone or messenger to the Engineer. In addition, the Contractor must promptly report in writing to the Engineer all accidents whatsoever arising out of or in connection with, the performance of the work whether on, or adjacent, to the site, giving full details and statements of witnesses.
- B. If a claim is made against the Contractor or any subcontractor on account of any accident, the Contractor shall promptly report the facts in writing to the Engineer, giving full details of the claim.

5.3 TRAFFIC MAINTENANCE AND SAFETY

- A. Comply with all rules and regulations of the state, county, and city authorities regarding closing or restricting the use of public streets or highways. No public or private road shall be closed, except by express permission of the owner. Conduct the work so as to assure the least possible obstruction to traffic and normal commercial pursuits. Protect all obstructions within traveled roadways by installing approved signs, barricades, and lights where necessary for the safety of the public. The convenience of the general public and residents adjacent to the project and the protection of persons and property are of prime importance and shall be provided for in an adequate and satisfactory manner.
- B. Maintenance of Traffic shall be maintained at all construction sites until the work is either completed or any open trenches have been properly covered and all equipment is properly stored. Contractor shall maintain Maintenance of Traffic (MOT) signs in good repairs and required MOT lights should be operative at all times. The Owner shall stop work if MOT is not properly maintained; there shall not be any additional cost to the Owner for this downtime.
- C. When flagmen and guards are required by regulation, permits, or when deemed necessary for safety, they shall be furnished with approved orange wearing apparel and other regulation traffic-control devices. Flaggers shall be certified by State approved agency.

5.4 STREET MAINTENANCE

- A. CONTRACTOR shall notify all residents and proprietors adjacent to construction site of work to be performed, more specifically the notice shall state the day and time construction will begin, the name and phone number of the Contractor's representative responsible for the completion of the proposed improvements. Notice shall also include the Owner's representative for the project.

5.5 FIRE PREVENTION AND PROTECTION

- A. The Contractor shall perform all work in a fire-safe manner and shall supply and maintain on the site adequate fire-fighting equipment capable of extinguishing incipient fires. The Contractor shall comply with applicable federal, state, and local fire-prevention regulations. Where these regulations do not apply, applicable parts of the National Fire Prevention Standard for Safeguarding Building Construction Operations (NFPA No. 241) shall be followed.

5.6 HURRICANE PREPAREDNESS PLAN

- A. Within 30 days of the date of Notice to Proceed, the CONTRACTOR shall submit to the ENGINEER and City Representative a Hurricane Preparedness Plan. The plan should outline the necessary measures which the CONTRACTOR proposes to perform at no additional cost to the OWNER in case of a hurricane warning.
- B. In the event of inclement weather, or whenever Owners Representative shall direct, CONTRACTOR will, and will cause Subcontractors to protect carefully the Work and materials against damage or injury from the weather. If, in the opinion of Owner's

Representative, any portion of Work or materials shall have been damaged or injured by reason of failure on the part of CONTRACTOR or any Subcontractors to so protect the Work, such Work and materials shall be removed and replaced at the expense of the CONTRACTOR.

6. PRESERVATION, RESTORATION AND CLEANUP

6.1 SITE RESTORATION AND CLEANUP:

- A. At all times during the work keep the premises clean and orderly and upon completion of daily work repair all damage caused by equipment and leave the project free of rubbish or excess materials of any kind.
- B. Stockpile excavated materials in a manner that will cause the least damage to adjacent lawns, grassed areas, gardens, shrubbery, or fences regardless of whether these are on private property, or State, County, or City rights-of-way. Remove all excavated materials from grassed and planted areas, and leave these surfaces in a condition equivalent to their original condition.

6.2 FINISHING OF SITE, BORROW, AND STORAGE AREAS

- A. Upon completion of the project, all areas used by the Contractor shall be properly cleared of all temporary structures, rubbish and waste materials and properly graded to drain and blend in with the abutting property. Areas used for the deposit of waste materials shall be finished to properly drain and blend in with the surrounding terrain.

6.3 AREA CLEANUP DURING CONSTRUCTION

- A. Thoroughly clean all spilled dirt, gravel, sand, concrete, or other foreign materials caused by the construction operations from all streets and roads, grass, pathways, or concrete walkways and from adjacent areas at the conclusion of each day's operation. Wet concrete is not to be stored, dumped, or placed on the ground or other structures on any City property at any time. Truck or equipment wash down is not to be performed on City Property.

6.4 DUST PREVENTION

- A. Give all unpaved areas used in the construction area an approved dust-preventive treatment or periodically water to prevent dust during construction. Applicable environmental regulations for dust prevention shall be strictly adhered to.

7. SUBMITTALS

- A. See Submittals section of the specifications

8. PAYMENT

8.1 GENERAL

A. The cost of the work in this section is considered incidental to the contract.

SECTION 01010
SCOPE OF WORK

PART 1 - SCOPE OF WORK

1.1 DESCRIPTION

- A. Work Included: the removal and replacement of four (4) fire pumps with controller, four (4) jockey pumps with controller, four (4) FDC with signage at the Key West Historic Seaport (2 locations, supplied by existing backflow) and City Marina @ Garrison Bight (2 locations, supplied by existing backflow) along with all equipment per the Supplemental Information provided in the document and all necessary appurtenances and record drawings, surveys, and incidental work to provide a complete and serviceable project identified as:

FIRE PUMPS REPLACEMENT
KEY WEST HISTORIC SEAPORT
CITY MARINA @ GARRISON BIGHT

1. Design, installation & materials to be in accordance with NFPA 20, current edition, installation of stationary pumps for fire protection and NFPA 13, current edition, standard for the installation of sprinkler systems.
 2. All wiring of panels and controllers by Electrical Contractor.
 3. Standard for the Installation of Stationary Pumps for Fire Protection per NFPA 20, Chapter 4, current edition.
 4. Pipe stand & hangers provided where necessary to properly support the fire pump piping per NFPA 20, current edition.
 5. All grooved fittings to be standard Victaulic fittings with grooved couplings or approved equal.
 6. Fire pump to be electric fire pumps, U.L. listed and F.M. approved per attached supplemental information.
 7. Fire pump acceptance testing, performance and maintenance shall meet the requirements of NFPA 20, current edition, chapter 14.
 8. All pipe to be schedule 10 and painted REDF with non-rust paint.
 9. Remove existing fire pump and install new fire pump within existing location. Location shall meet all NFPA 20, current edition and local requirements.
 10. The fire pump contractor shall provide signed and sealed shop drawings.
 11. Fire pump contractors shall be licensed by the City of Key West, along with the State of Florida as a Fire Protection 1 contractor.
- B. The sites consist of an electric fire pump to be removed and new electric fire pump to be installed along with controller, as well as jockey pump and controller. Sites supplied by existing backflow. Contractor responsible for disposal of all removed pumps and equipment.

Provide and install new electric fire pumps to supply fire protection water to the existing locations and any sprinkler system that may be part of the system. Refer to Supplemental Information included in this document.

The existing fire pump locations are to remain and shall meet NFPA 20 requirements.

Fire Department Connections (FDC) shall be installed, as well as signage. All fire pumps are sized to meet existing conditions.

The Supplemental Information within this document provides the complete requirements for the replacement of each fire pump and equipment at all four (4) locations.

1. Key West Bight Ferry Terminal
2. Key West Bight, Margaret Street
3. City Marina West
4. City Marina East

C. Related requirements in other parts of the Contract Documents: General and Supplementary Conditions of the Contract for Construction.

D. Contractor's Duties:

1. In addition to provisions stipulated in other portions of the Contract Documents, the Contractor shall:

- a. Secure permits as necessary for proper execution and completion of the work.
- b. Notify (in writing) all residents and proprietors adjacent to construction site of work to be performed, more specifically the notice shall state the day and time construction will begin, hours of work, the name and phone number of the Contractor's Superintendent and an end date for the project.

E. The Contractor shall be totally responsible for all permits required and shall ensure that construction complies with all applicable local, state, and federal codes.

F. Provide an experienced, qualified, and competent Superintendent to oversee the Work and perform quality assurance inspections. Prior to starting construction, the proposed Superintendent's qualifications shall be submitted in writing to the City for approval. The approved Superintendent shall be expected to remain for the duration of the Project, unless the City or Engineer deem him/her inadequate and requests his/her removal or the Contractor cannot continue his services to the Project for a reason or reasons that shall be communicated in writing to the City.

G. A replacement Superintendent shall be required to follow the same approval process as required for the original. The Superintendent shall provide to the City Inspector Construction Reports for each day of construction, the reports shall be in English, legible, and signed. Contractor shall provide PDF copies monthly. Reports shall include quantity control checks done daily.

H. It shall be the Contractor's responsibility to request approval for entrance to the site for work on Saturdays, Sundays, holidays, and weekday hours other than 7:00 AM until 7:00 PM. No construction can commence before 8:00 AM on weekdays.

- I. The Contractor shall provide material safety data sheets (2 copies) for chemicals, paints, coatings, and materials used on-site prior to initiation of work.

1.2 CONTRACTOR'S USE OF PREMISES

- A. Work shall be scheduled as to not interfere with on-going area activities.
- B. Coordinate use of premises and requirements for security under direction of City.
- C. Assume full responsibility for the protection and safekeeping of products, under this Contract, stored on the site.
- D. Obtain and pay for the use of additional storage or work areas needed for operation.
- E. Contractor shall provide drinking water and toilet facilities for construction personnel; The City will not provide.

1.3 MAINTENANCE OF EXISTING UTILITIES OPERATION

- A. Provide at least three weeks' notice prior to interruption of utility services for temporary or permanent connections.
- B. Keep interruption of utility services, and utility outages during disconnection, moving, and reconnection to a minimum.
- C. All connections shall be installed and tested up to existing fire pump system. Once tested and approved, connection can be made. System down time must be limited to less than 24 hours. If down time is greater than 24 hrs. It shall be contractors' responsibility to provide Fire Watch at contractor's expense. Coordinate any fire watch needs with Lt. Michael Anderson, 305-809-3917 or michael.anderson@cityofkeywest-fl.gov.

Testing shall be approved AHJ prior to connections being made.

- D. Keys Energy shall be notified two weeks in advance in writing by the contractor for any KEYS support equipment required by the Contractor during any excavation. (e.g., Power poles next to excavations requiring support, etc.) No additional payment will be paid for this coordination.

**SECTION 01014
PROTECTION OF THE ENVIRONMENT**

PART 1 GENERAL

- A. The Contractor shall maintain all work areas within and outside the project boundaries free from environmental pollution, which would be in violation to any federal, state, or local regulations.
- B. The work specified in this Section consists of designing, providing, maintaining and removing temporary erosion and sedimentation controls as necessary.
- C. Temporary erosion controls include, but are not limited to, grassing, mulching, watering, and reseeding on-site surfaces and spoil and borrow area surfaces and providing interceptor ditches at ends of berms and at those locations which will ensure that erosion during construction will be either eliminated or maintained within acceptable limits as established by the OWNER.
- D. Temporary sedimentation controls include, but are not limited to, silt dams, traps, barriers, and appurtenances at the foot of sloped surfaces which will ensure that sedimentation pollution will be either eliminated or maintained within acceptable limits as established by the OWNER.
- E. CONTRACTOR is responsible for providing effective temporary erosion and sediment control measures during construction or until final controls become effective.

PART 2 PROTECTION OF AIR QUALITY

- A. The air pollution likely to occur due to construction operations shall be minimized by wetting down bare soils during windy periods, requiring the use of properly operating combustion emission control devices on construction vehicles and equipment used by contractors, and by encouraging the shutdown of motorized equipment not actually in use.
- B. Trash burning will not be permitted on the construction site.
- C. Contractor shall provide dust control for any asphalt / concrete removal and during the asphalt milling operations.

PART 3 CONSTRUCTION NOISE CONTROL

1 GENERAL

- A. The Contractor shall conduct all his work, use appropriate construction methods and equipment, and furnish and install acoustical barriers, all as necessary so that no noise emanating from the process or any related tool or equipment will exceed legal noise levels, as set forth in the Code of Ordinances, City of Key West, Florida.

2. MITIGATION OF CONSTRUCTION NOISE IMPACT

- A. The Contractor shall submit to the Engineer his plans to mitigate the construction noise impacts and to comply with the noise criteria specified herein, including the method of construction, the equipment to be used, and acoustical treatments if necessary.

PART 4 PAYMENT

7.1 GENERAL

- A. Payment for the work will be incidental to the contract.

* * * * *

**SECTION 01050
FIELD ENGINEERING**

PART 1 GENERAL

1.01 DESCRIPTION:

A. Work Included:

1. Provide field-engineering services required for the Project, including but not limited to:
 - a. Survey work required in execution of the Work.
 - b. Civil, Structural, or other professional engineering services specified or required to execute the Contractor's construction methods.

B. Related Work:

1. General and Supplementary Conditions of the Contract.
2. Section 01010 Scope of Work.

1.02 QUALITY ASSURANCE:

- A. Qualifications of Surveyor or Engineer: Professional Engineer and/or Surveyor currently licensed in the State of Florida.

1.03 SUBMITTALS:

- A. Submit name and address of proposed Surveyor and/or Contractor's Engineer to the City.
- B. Upon request of the City's Engineer, submit documentation to verify accuracy of field engineering work.
- C. Submit certificates signed by the Surveyor or Engineer certifying that elevations and locations of the work of this Project are in conformance, or non-conformance, with the Contract Documents.

PART 2 EXECUTION

2.01 EXAMINATION AND PREPARATION OF SITE

- A. Before starting operations, Contractor shall examine site of work to acquaint himself with conditions to be encountered.
- B. Compare actual site with drawings and specifications.
- C. Report discrepancies affecting work or cost thereof to the City.
- D. Verify exact locations of sewers, water mains, gas mains, above or below ground electrical wires and conduits and structures which may interfere with work.

- E. No extra compensation will be allowed for any extra work made necessary due to conditions or obstacles encountered during progress of work, which could have been determined by examination of site or by contacting Owners of utilities, pipelines and conduits before starting operations.
- F. Comply with State law concerning Sunshine State One Call of Florida, State Statute Title 33, Chapter 556.

2.02 LINES AND GRADES

- A. Prior to staking out work, Contractor shall verify established base line, benchmarks, and control points provided.
- B. Contractor shall furnish and maintain lines and grades.
- C. Contractor shall take immediate steps to correct errors or inconsistencies in lines and grades of work to be in conformity with Contract Documents.
- D. Contractor shall be fully responsible for accuracy of lines and grades of work and control and checking and immediate correction of it.

2.03 RESTORATION

- A. Items to remain which are disturbed, damaged, or removed when performing required work or for convenience of Contractor or to expedite his operations shall be restored, repaired, reinstalled, or replaced with new work and refinished, as appropriate, so as to be left in a good condition as existed before work commenced and such restoration shall be considered incidental to the work.
- B. Any sidewalks or pavement replaced or installed shall meet ADA requirements.
- C. Existing items to be altered, extended, salvaged, or relocated and reused, if found to be defective in any way, shall be reported to the City before items are disturbed.
- D. Materials and workmanship used in restoring work shall conform in type and quality to original existing construction.

PART 4 - PAYMENT

4.1 GENERAL

- A. Payment for work specified in this section will be incidental to the contract.

SECTION 01300
SUBMITTALS

PART 1 GENERAL

1.01 GENERAL

- A. Inquiries: Direct to ENGINEER regarding procedure, purpose, or extent of Submittal.
- B. Submittal Submission Procedures: As provided in General Conditions, as specified herein, and as may otherwise be established during the preconstruction conference.
- C. OWNER's Authorization: At any time, OWNER may authorize changes to procedures and requirements for Submittals, as necessary to accomplish specific purpose of each Submittal. Such authorization will be by Field Order or Work Change Directive.
- D. Timeliness: Make submissions in accordance with requirements of individual Specification sections, as shown on the current accepted schedule of Submittals submissions, and in such sequence as to cause no delay in Work or in work of other contractors.
- E. Identification of Submittals:
 - 1. Complete, sign, and transmit with each Submittal package, one Transmittal of CONTRACTOR's Submittal Form attached at the end of this section.
 - 2. Identify each Submittal with numbering and tracking system reviewed by ENGINEER:
 - a. Sequentially number each Submittal.
 - b. Resubmission of a Submittal will have original number with sequential alphabetic suffix.
 - 3. Show date of submission and dates of previous submissions.
 - 4. Show Project title and OWNER's contract identification and contract number.
 - 5. Show names of CONTRACTOR, Subcontractor or Supplier, and manufacturer as appropriate.
 - 6. Identify, as applicable, Contract Document section and paragraph to which Submittal applies.
 - 7. Clearly identify revisions from previous submissions.
- F. Incomplete Submittal Submissions:
 - 1. At ENGINEER's sole discretion, ENGINEER will either (i) return the entire Submittal for CONTRACTOR's revision/correction and resubmission, or (ii) retain portions of the Submittal and request submission/resubmission of specified items or as noted thereon.
 - 2. Submittals which do not clearly bear CONTRACTOR's specific written indication of CONTRACTOR review and approval of Submittal or which are transmitted with an unsigned or uncertified submission form or as may otherwise be required under Contract Documents, will be returned to

CONTRACTOR unreviewed for resubmission in accordance with Contract Documents.

3. Delays, resequencing or other impact to Work resulting from CONTRACTOR's submission of unchecked or unreviewed, incomplete, inaccurate or erroneous, or nonconforming Submittals, which will require CONTRACTOR's resubmission of a Submittal for ENGINEER's review, shall not constitute a basis of claim for adjustment in Contract Price or Contract Times.

F. Non-specified Submissions: Submissions not required under these Contract Documents and not shown on schedule of Submittals submissions will not be reviewed and will be returned to CONTRACTOR.

G. Transmit Submittals in accordance with current accepted schedule of Submittal submissions, and deliver as follows:

1. Submittals to: Designated Engineer by the General Service Department of the City of Key West.

H. Disposition of Submittals: As specified herein for administrative Submittals. ENGINEER will review, stamp, and indicate requirements for resubmission or acceptance on Submittal as follows:

1. Reviewed as Noted:
 - a. Reference the General Conditions for intent.
 - b. CONTRACTOR may proceed to perform Submittal related Work.
 - d. One copy for ENGINEER's file.
 - e. One copy returned to CONTRACTOR.
2. Revise and Resubmit (Revise/Correct or Develop Replacement and Resubmit):
 - a. Revise/correct in accordance with ENGINEER's comments and resubmit.
 - b. One copy to ENGINEER's file.
 - c. One copy returned to CONTRACTOR appropriately annotated.

I. ENGINEER's Review: ENGINEER will act upon CONTRACTOR's Submittal and transmit response to CONTRACTOR not later than 30 days after receipt, unless: (i) specified otherwise or (ii) accepted by ENGINEER as set forth in Paragraph ENGINEER's Duties below and identified on current accepted schedule of Submittals submissions. Re-submittals will be subject to the same review time.

1.02 SHOP DRAWINGS

A. Description: Reference the General Conditions.

B. Excessive Shop Drawing Review: Review of the first submission and two resubmissions of Shop Drawings will be performed by ENGINEER at no cost to CONTRACTOR.

Subsequent additional resubmissions of that Shop Drawing will be reviewed by ENGINEER, however, ENGINEER will document work hours and other expenses required to perform such additional review(s). OWNER shall deduct these costs from Contractor's contract for reimbursement to the ENGINEER.

C. Copies: Submit two (2) copies.

D. Submit Shop Drawings to ENGINEER in accordance with the General Conditions and as specifically required by individual Specification sections for equipment and materials to be furnished under these Contract Documents.

E. Identify and Indicate:

1. Pertinent Drawing sheet(s) and detail number(s), products, units and assemblies, and system or equipment identification or tag numbers.
2. Critical field dimensions and relationships to other critical features of Work.
 - a. Each deviation or variation from Contract Documents.

F. Resubmissions: Clearly identify each correction or change made.

G. Foreign Manufacturers: When proposed, include following additional information:

1. Names and addresses of at least two companies closest to Project that maintain technical service representatives.
2. Complete inventory of spare parts and accessories for each piece of equipment.

H. Preparation:

1. Format: Whenever possible, schedule for and combine Shop Drawings required for submission in each Specification section into a single Submittal package.
2. Present in a clear and thorough manner and of sufficient detail to show kind, size, arrangement, and function of components, materials, and devices and compliance with Contract Documents. Identify details by reference to sheet and detail, and schedule or room numbers shown on Drawings.

PART 4 PAYMENT

B. Payment for the work in this section will be incidental

* * * * *

SECTION 01530
BARRIERS

PART 1 - GENERAL

1.01 REQUIREMENTS

Furnish, install, and maintain suitable barriers as required to prevent public entry, and to protect the work, existing facilities, trees, and plants from construction operations; remove when no longer needed, or at completion of work.

1.02 RELATED REQUIREMENTS

A. Section 01010 Scope of Work.

PART 2 - PRODUCTS

2.01 MATERIALS - GENERAL

Materials may be new or used, suitable for the intended purpose, but must not violate requirements of applicable codes and standards.

2.02 FENCING

Minimum fence height shall be four feet. Open-mesh orange plastic fence shall be used to prohibit entry to the construction zone.

2.03 BARRIERS

Materials are Contractor's option, as appropriate to serve required purpose.

PART 3 - EXECUTION

3.01 GENERAL

- A. Install facilities of a neat and reasonably uniform appearance, structurally adequate for the required purposes.
- B. Maintain barriers during entire construction period.
- C. Relocate barriers as required by the progress of construction.

3.02 FENCES

- A. Provide and maintain fences necessary to assure security of the site during construction to keep unauthorized people and animals from the site when construction is not in progress.
- B. Provide additional security measures as deemed necessary and approved by the OWNER.

3.03 TREE AND PLANT PROTECTION

- A. Preserve and protect existing trees and plants at site which are designated to remain, and those adjacent to site.
- B. Consult with the OWNER, and remove agreed-on roots and branches which interfere with construction. Employ a qualified tree surgeon to remove branches and treat cuts.
 - B. Protect root zones of trees and plants:
 - 1. Do not allow vehicular traffic or parking.
 - 2. Do not store materials or products.
 - 3. Prevent dumping of refuse or chemically injurious materials or liquids.
 - 4. Prevent puddling or continuous running water.
- D. Carefully supervise excavating, grading and filling, and other construction operations, to prevent damage.
- E. Replace, or suitably trim trees and plants designated to remain which are damaged or destroyed due to construction operations.

3.04 REMOVAL

- A. Completely remove barricades when construction has progressed to the point that they are no longer needed and when approved by the OWNER.
- B. Repair damage caused by construction. Fill and grade areas of the site to the required elevations, and clean up the area.

SECTION 01700
CONTRACT CLOSEOUT

PART 1 - GENERAL

1.01 REQUIREMENTS

Contract completion includes substantial completion, final inspection after completion, final cleaning, contractor's closeout submittals, and final adjustment of accounts.

1.02 SUBSTANTIAL COMPLETION

- A. When Contractor considers work has reached substantial completion, he shall submit to the OWNER the following:
 - a. Written notice that the work is substantially complete in accordance with Contract Documents.
 - b. A list of items yet to be completed or corrected and explanations thereof.
- B. Within a reasonable time upon receipt of such notice, the OWNER will make an inspection, if necessary, to determine the status of completion.
- C. Should the OWNER determine that the work is not substantially complete:
 - a. The OWNER will promptly notify the Contractor in writing, giving the reasons thereof.
 - b. Contractor shall remedy the deficiencies in the work and send a second written notice of Substantial Completion to the OWNER.
 - c. Upon receipt of the second notice, the OWNER will review the work.
- D. When the OWNER finds that the Work is substantially complete he will issue a Certificate of Substantial Completion with a tentative list of items to be completed or corrected before final inspection.

1.03 FINAL INSPECTION AFTER COMPLETION

- A. When Contractor considers the Work is complete with all minor deficiencies completed or corrected, he shall submit written certification that:
 - a. Contract Document requirements have been met.

- b. Work has been inspected for compliance with Contract Documents.
 - c. Work has been completed in accordance with Contract Documents.
 - d. All minor deficiencies have been corrected or completed and the Work is ready for final inspection.
 - e. Project record documents are complete and submitted.
- B. Within a reasonable time upon receipt of such certification, the OWNER will make an inspection to verify the status of completion.
 - C. Should the OWNER determine that the work is incomplete or defective:
 - a. The OWNER will promptly notify the Contractor in writing, listing the incomplete or defective work.
 - b. Contractor shall remedy the deficiencies in the work and send a second written certification to the OWNER that the work is complete.
 - c. Upon receipt of the second certification, the OWNER will review the Work.
 - D. When the OWNER determines that the work is acceptable, under the Contract Documents, he shall request the Contractor to make closeout submittals.

1.04 FINAL CLEANING

- A. Execute final cleaning prior to final inspection.
- B. Clean site; sweep paved areas, rake clean other surfaces.
- C. Remove waste and surplus materials, rubbish, and construction facilities from the Project and from the site.

1.05 CONTRACTOR'S CLOSEOUT SUBMITTALS

- A. Project Record Documents
 - a. At Contract Closeout, submit documents with transmittal letter containing date, project title, Contractor's name and address, list of documents, and signature of Contractor.
 - b. Changes made by Field Order or by Change Order.
- B. Evidence of payment and Release of Liens.

1.06 FINAL ADJUSTMENT OF ACCOUNTS

- A. Submit a final statement of accounting to the OWNER.
- B. Statement shall reflect all adjustments to the Contract Sum.
 - a. The original Contract sum.
 - b. Additions and deductions resulting from:

- Previous change orders or written amendment.
 - Allowances
 - Unit prices
 - Deductions for uncorrected work.
 - Deductions for liquidated damages
 - Other adjustments
- c. Total contract sum as adjusted
- d. Previous payments
- e. Sum remaining due

PART 2 - PRODUCTS (not used)
PART 3 - EXECUTION (not used)

PART 5

SUPPLEMENTAL INFORMATION

PUMP LOCATION #2
KWB MARGARET ST

PUMP LOCATION #1
KWB FERRY TERMINAL

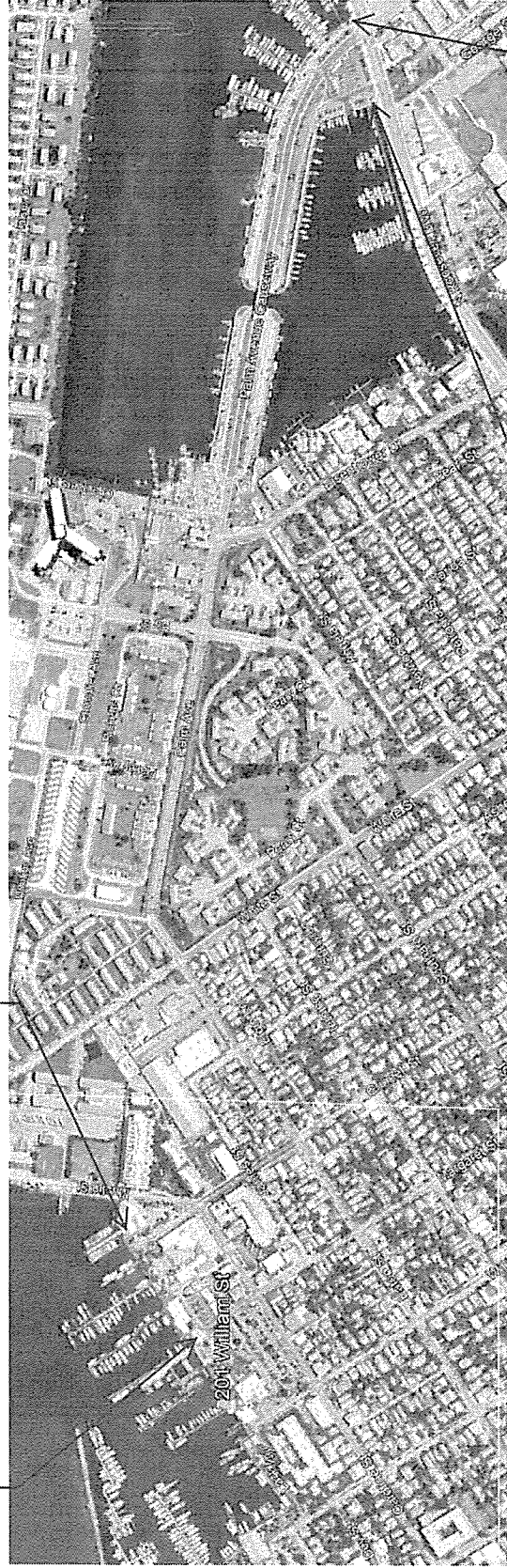

PUMP LOCATION #4
GARRISON BIGHT EAST

PUMP LOCATION #3
GARRISON BIGHT WEST

LOCATION(S) MAP

(NTS)

PUMP #1

KEY WEST BIGHT FERRY TERMINAL



City of Key West			
Project name	Bight Ferry Terminal	Quote Number / ID	A-20347-F
Customer	City of Key West	Model / Stages	5PVF7 / 1
Tag Number		Flow, rated	500 USgpm
Customer ref. / PO		Differential head / pressure, rated	55.00 psi
		Speed, rated	3520 rpm

LEAD TIME			
		Lead Time Total	8 wks

Pump	
Qty	Description
1	<p>5PVF7</p> <p>Fire Pump System</p> <p>Mount</p> <p>PumpType: New Pump</p> <p>Scope of Supply: Fire Pump with driver and controller</p> <p>Pump</p> <p>Pump model: 5PVF7</p> <p>Selected pump listing: FM/UL Listed</p> <p>Casing material: Cast Iron</p> <p>Suction flange: 125lb ANSI Flat faced</p> <p>Discharge flange: 125lb ANSI Flat faced</p> <p>Impeller material: Silicon Brass</p> <p>Impeller Wear Ring: Integral</p> <p>Rotation: Clockwise (RH)</p> <p>Shaft material: Carbon steel</p> <p>Shaft sleeve material: Bronze with O-ring</p> <p>Packing type: Standard</p> <p>Nameplate units: US</p> <p>Coating: Standard Red Enamel</p> <p>Tests & Certifications</p> <p>Performance Tests</p> <p> Non-witnessed Performance Test</p> <p>Hydrostatic Pressure Tests</p> <p> Non-witnessed Hydrostatic Test</p> <p>Driver Type</p> <p>Motor Phase: 3 Phase</p>

Driver	
Qty	Description
1	<p>Fire Pump System</p> <p>Driver Type</p> <p>Motor supplied by: Standard factory motor</p> <p>Motor voltage: 200 V</p> <p>Frequency: 60 Hz</p> <p>Starting method: Direct-on-line (DOL)</p> <p>Motor enclosure: Open Drip Proof</p> <p>Motor efficiency: Any</p> <p>Motor manufacturer: All motors</p> <p>Motor: Motor-electric, Q2536OP3VFP256JPV-S 256JPV, 25hp, 200V, 60Hz, 3600 rpm WEG, IE2, 1.15</p>



Accessories

Qty	Description
1	Jockey pump casing relief valve: None selected Casing relief valve: Valve, casing relief, ClaVal, 0.75", 20-300psi, Listing: UL/FM Gauge: -14InHg/290psi Suction, 0-300psi Discharge Hose valve head: 4", Grooved, 0-500USgpm, 400psi MWP, 2 outlets, Cla-Val Hose valve: Valve, hose angle, 2.5" NPT internal thread, National standard, 300psi MWP, Listing: UL/FM

Controller

Qty	Description
1	Controller brand: Tornatech Controller voltage: 200-208 V Transfer switch: No Controller frequency: 60 Hz Direct Ship Controller: No Controller type: Tornatech GPA Full voltage across the line starter, 25-25hp, 200-208V, 60hz Enclosure: - NEMA 2 Enclosure type: NEMA Type 2 Withstand Ratings (Controller): - Standard (see manufacturer documentation for value)

Jockey Pump

Qty	Description
1	Jockey pump supply: Grundfos CR Frequency: 60 Hz Phase: Three Voltage: 208 V Flow rate: Flow rated: 5 USgpm Total discharge head: Total discharge head: 65.00 psi Direct Ship Jockey Pump: No Jockey pump selected: CR 1-6-3ph/0.75Hp 56CFr Duty point: 6USgpm, 69.3psi, Shutoff pressure: 75.8psi, 208V, Oval flange, HQQE Seal type Jockey pump companion flange kit: 250# Flange fitting set (CR1S/1/3/5)

Jockey Pump Controller

Qty	Description
1	Jockey pump controller required: Yes Manufacturer: Tornatech Voltage: 200-208 V Frequency: 60 Hz Direct ship jockey pump controller: No Jockey pump controller selected: Tornatech Controller JP3, Across the line starter, 0.75hp, 200-208V, 3Ph, 60hz Enclosure: - NEMA 2 Enclosure type: NEMA Type 2 Application options: - None

Engineered Skid Package

Qty	Description
1	Engineered Packaged Skid: Not Required



Commercial	
Qty	Description
1	Shipping Container: Standard Skid Incoterms 2020: FCA Freight Pre-paid and add Named Place:



Pump Performance Curve

Performance based on test acceptance - Hyd Inst 14.6 Unilateral (1U)
 The rated point is the only guaranteed point (within the specified HI grade) on the performance curve.
 The published closed valve head has a +6% tolerance.

Other specified duty points, including their tolerances, shall be per separate agreement between Peerless Pump Co. and buyer.

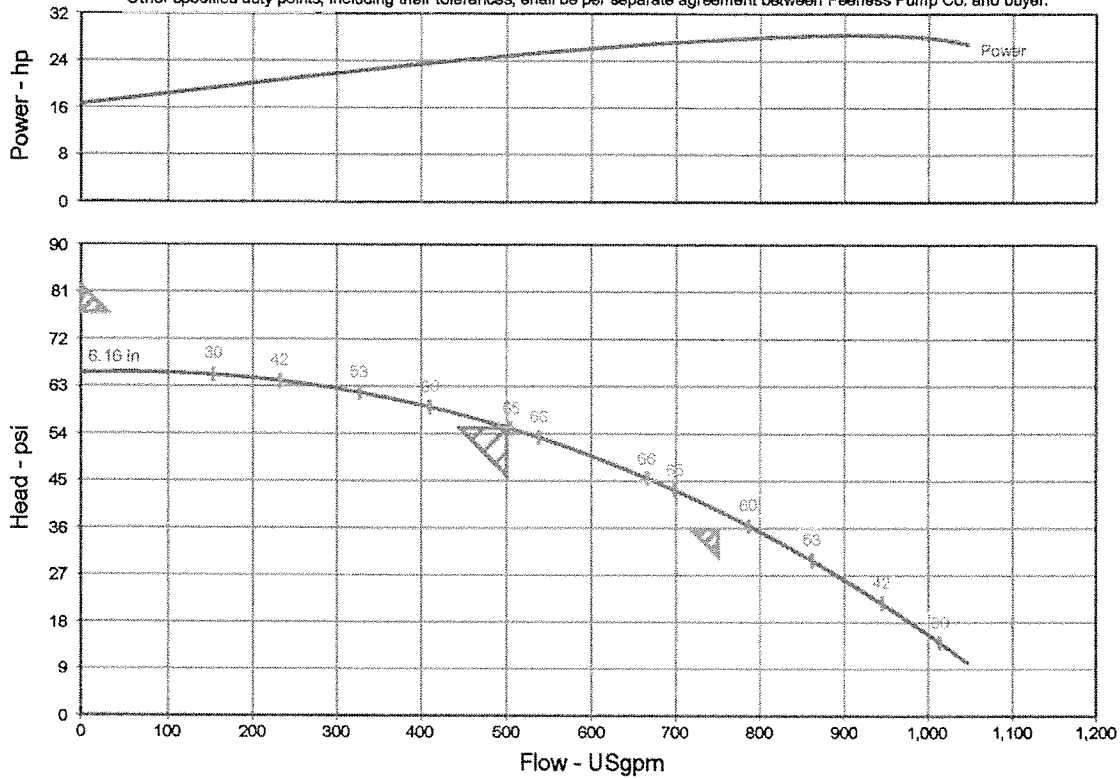

Customer	: Florida Keys Fire	Peerless Model	: 5PVF7
Customer ref. / PO	:	Stages	: 1
Tag Number	: 001	Speed, rated	: 3520 rpm
Service	:	Based on curve number	: 5PVF7-3520 Rev OCT 2020
Quantity	: 1	Efficiency	: 64.84 %
Quote Number / ID	: A-20347-F	Rated power (based on duty point)	: 24.8 hp
Date last saved	: 29 Mar 2023 1:46 PM	Max power (non-overloading)	: 28.4 hp
Flow, rated	: 500 USgpm	NPSH required	: -
Differential head / pressure, rated	: 55.00 psi	Viscosity	: 1.00 cP
Fluid density, rated / max	: 1.000 / 1.000 SG	Cq/Ch/Ce/Cn [ANSI/HI 9.6.7-2010]	: 1.00 / 1.00 / 1.00 / 1.00

Flow (USgpm)	Head (psi)	Efficiency (%)	Power (hp)	NPSHr (ft)	Thrust, total (lbf)
0	65.54	0.00	16.6	-	-
116	65.45	23.81	18.7	-	-
233	64.00	42.01	20.7	-	-
349	61.13	55.10	22.6	-	-
466	56.77	63.33	24.3	-	-
582	50.84	66.71	25.9	-	-
698	43.28	64.99	27.1	-	-
815	34.02	57.68	28.0	-	-
931	23.00	44.05	28.4	-	-
1,048	10.15	23.11	26.8	-	-



General Arrangement General Arrangement

Installing Contractor(s) To Install Equipment In Accordance With Latest Editions Of National Electric Code, Local Codes And NFPA Pamphlet No. 20 Applicable To Fire Pump Installations.

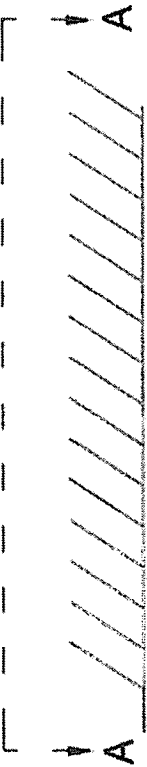

Clearance Recommended To Remove Motor

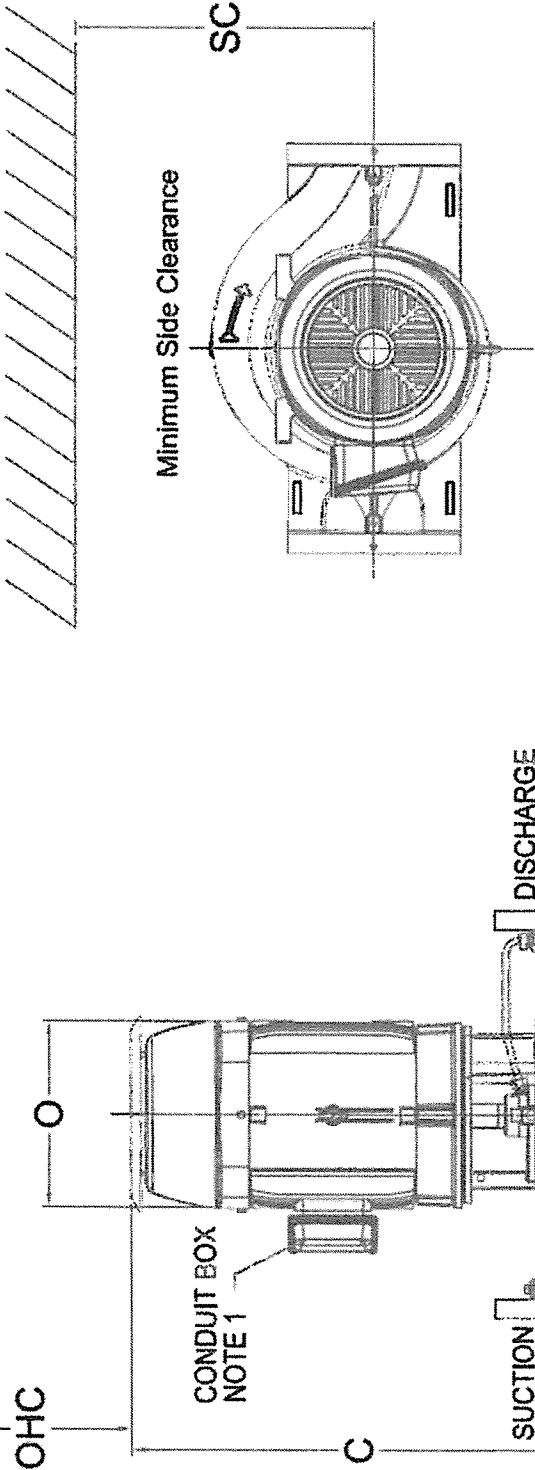

NOTE 1
CONDUIT BOX IS LOCATED 45 DEG FROM SUCCTION WHEN VIEWED FROM TOP AND MAY BE ROTATED IN 90 DEG INCREMENTS

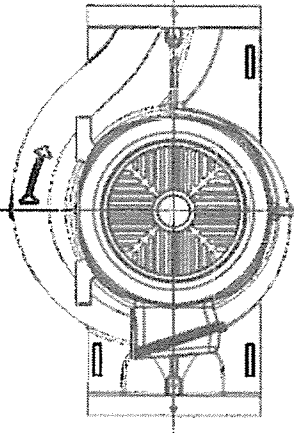

VIEW A-A

(H) = Diameter
(N) = # Of Holes
(HE) = Diameter Of Bolt Circle

OHC	22.00 in	HA	11.00 in	SC	18.00 in	Discharge	5.00 in
O	7.25 in	HG	0.56 in	H	0.50 in	Suction	5.00 in
C	37.00 in	VY	11.00 in	N	4.00 in		
VD	10.00 in	X	9.50 in	HE	9.88 in		

GENERAL	
Pump Model	5PVF7
Listing / Approval	FM/UL Listed
Rated Flow	500 USgpm
Liquid Rated	Cold Water
Pressure	55.00 psi
Specific Gravity	0.99824
Rated Speed	3520 rpm
MOTOR	
Manufacturer	WEG
Enclosure	ODP
Hp	25.0 hp
Frame	25AJPV
Volt/Ph/Hz	200V / 3Ph / 60Hz
Service Factor	1.15
Customer	
Customer	Florida Keys Fire
Quote No.	A-20047-F
Item No.	001
Project	Eight Ferry Terminal
Date	03/29/2023



City of Key West Fire Pump Replacement

FIRE PUMP GENERAL NOTES

1. DESIGN, INSTALLATION & MATERIALS TO BE IN ACCORDANCE WITH NFPA 20, 2016 EDITION, INSTALLATION OF STATIONARY PUMPS FOR FIRE PROTECTION AND NFPA 13, 2016 EDITION, STANDARD FOR THE INSTALLATION OF SPRINKLER SYSTEMS.
2. ALL WIRING OF PANELS AND CONTROLLERS BY ELECTRICAL CONTRACTOR.
3. PIPE STANDS & HANGERS PROVIDED WHERE NECESSARY TO PROPERLY SUPPORT THE FIRE PUMP PIPING PER NFPA 20, 2016 EDITION.
4. ALL GROOVED FITTINGS TO BE STANDARD VICTAULIC FITTINGS WITH GROOVED COUPLINGS OR APPROVED EQUAL.
5. FIRE PUMP TO BE CITY APPROVED ELECTRIC PEERLESS FIRE PUMPS, U.L. LISTED AND F.M. APPROVED PER SPECIFICATIONS ATTACHED.
6. FIRE PUMP ACCEPTANCE TESTING, PERFORMANCE AND MAINTENANCE SHALL MEET THE REQUIREMENTS OF NFPA 20, 2016 EDITION CHAPTER 14.
7. ALL PIPE TO BE SCHEDULE 10 AND PAINTED REDF WITH NON-RUST PAINT.
8. REMOVE EXISTING FIRE PUMP AND INSTALL NEW FIRE PUMP WITHIN EXISTING LOCATION. LOCATION SHALL MEET ALL NFPA 20, 2016 EDITION AND LOCAL REQUIREMENTS.
9. THE FIRE PUMP CONTRACTOR SHALL PROVIDE SHOP DRAWINGS.
10. FIRE PUMP CONTRACTOR SHALL BE LICENSED BY THE CITY OF KEY WEST, ALONG WITH THE STATE OF FLORIDA AS A FIRE PROTECTION 1 CONTRACTOR.

City of Key West Fire Pump Replacement

SCOPE OF WORK

THIS SITE CONSISTS OF AN EXISTING ELECTRIC FIRE PUMP TO BE REMOVED AND NEW PEERLESS FIRE PUMP WILL BE INSTALLED ALONG WITH CONTROLLER, AS WELL AS JOCKEY PUMP AND CONTROLLER. SITE SUPPLIED BY AN EXISTING BACKFLOW.

PROVIDE AND INSTALL NEW PEERLESS ELECTRIC FIRE PUMP TO SUPPLY FIRE PROTECTION WATER TO THE EXISTING LOCATION AND ANY SPRINKLER SYSTEM THAT MAYBE PART OF SYSTEM. SEE ATTACHED PEERLESS FIRE PUMP DESCRIPTION, ALONG WITH EQUIPMENT ATTACHED.

THE EXISTING FIRE PUMP LOCATION IS TO REMAIN AND SHALL MEET NFPA 20 REQUIREMENTS.

FIRE DEPARTMENT CONNECTION SHALL BE INSTALLED, AS WELL AS SIGNAGE. THE FIRE PUMP IS SIZED TO MEET THE EXISTING CONDITIONS.

FIND ATTACHED COMPLETE REQUIREMENT AND SPECIFICATIONS FOR THE REPLACEMENT OF EXISTING FIRE PUMP AT THIS LOCATION.

PUMP #2

KEY WEST BIGHT – MARGARET STREET



City of Key West			
Project name	Margaret Street	Quote Number / ID	A-20348-F
Customer	City of Key West	Model / Stages	5PVF11 / 1
Tag Number		Flow, rated	500 USgpm
Customer ref. / PO		Differential head / pressure, rated	95.00 psi
		Speed, rated	3550 rpm

LEAD TIME			
		Lead Time Total	8 wks

Pump	
Qty	Description
1	<p>5PVF11</p> <p>Fire Pump System</p> <p>Mount</p> <p>PumpType: New Pump</p> <p>Scope of Supply: Fire Pump with driver and controller</p> <p>Pump</p> <p>Pump model: 5PVF11</p> <p>Selected pump listing: UL Listed</p> <p>Casing material: Cast Iron</p> <p>Suction flange: 125lb ANSI Flat faced</p> <p>Discharge flange: 125lb ANSI Flat faced</p> <p>Impeller material: Silicon Brass</p> <p>Impeller Wear Ring: Integral</p> <p>Rotation: Clockwise (RH)</p> <p>Shaft material: Carbon steel</p> <p>Shaft sleeve material: Bronze with O-ring</p> <p>Packing type: Standard</p> <p>Nameplate units: US</p> <p>Coating: Standard Red Enamel</p> <p>Tests & Certifications</p> <p>Performance Tests</p> <p> Non-witnessed Performance Test</p> <p>Hydrostatic Pressure Tests</p> <p> Non-witnessed Hydrostatic Test</p> <p>Driver Type</p> <p>Motor Phase: 3 Phase</p>

Driver	
Qty	Description
1	<p>Fire Pump System</p> <p>Driver Type</p> <p>Motor supplied by: Standard factory motor</p> <p>Motor voltage: 460 V</p> <p>Frequency: 60 Hz</p> <p>Starting method: Direct-on-line (DOL)</p> <p>Motor enclosure: Open Drip Proof</p> <p>Motor efficiency: Any</p> <p>Motor manufacturer: All motors</p> <p>Motor: Motor-electric, 05036OP3EFP324JPV-W4 324JPV, 50hp, 460V, 60Hz, 3600 rpm WEG, IE2, 1.15</p>



Accessories

Qty	Description
1	Jockey pump casing relief valve: None selected Casing relief valve: Valve, casing relief, ClaVal, 0.75", 20-300psi, Listing: UL/FM Gauge: -14InHg/290psi Suction, 0-300psi Discharge Hose valve head: 4", Grooved, 0-500USgpm, 400psi MWP, 2 outlets, Cla-Val Hose valve: Valve, hose angle, 2.5" NPT internal thread, National standard, 300psi MWP, Listing: UL/FM

Controller

Qty	Description
1	Controller brand: Tornatech Controller voltage: 440-480 V Transfer switch: No Controller frequency: 60 Hz Direct Ship Controller: No Controller type: Tornatech GPA Full voltage across the line starter, 50-50hp, 440-480V, 60hz Enclosure: - NEMA 2 Enclosure type: NEMA Type 2 Withstand Ratings (Controller): - Standard (see manufacturer documentation for value)

Jockey Pump

Qty	Description
1	Jockey pump supply: Grundfos CR Frequency: 60 Hz Phase: Three Voltage: 460 V Flow rate: Flow rated: 5 USgpm Total discharge head: Total discharge head: 105.0 psi Direct Ship Jockey Pump: No Jockey pump selected: CR 1-9-3ph/1Hp 56CFr Duty point: 6USgpm, 103.9psi, Shutoff pressure: 112.1psi, 460V, Oval flange, HQQE Seal type Jockey pump companion flange kit: 250# Flange fitting set (CR1S/1/3/5)

Jockey Pump Controller

Qty	Description
1	Jockey pump controller required: Yes Manufacturer: Tornatech Voltage: 440-480 V Frequency: 60 Hz Direct ship jockey pump controller: No Jockey pump controller selected: Tornatech Controller JP3, Across the line starter, 1.00hp, 440-480V, 3Ph, 60hz Enclosure: - NEMA 2 Enclosure type: NEMA Type 2 Application options: - None

Engineered Skid Package

Qty	Description
1	Engineered Packaged Skid: Not Required

Commercial

Qty	Description
1	Shipping Container: Standard Skid



Commercial	
Qty	Description
	Incoterms 2020: FCA Freight Pre-paid and add Named Place:



Pump Performance Curve

Performance based on test acceptance - Hyd Inst 14.6 Unilateral (1U)
 The rated point is the only guaranteed point (within the specified HI grade) on the performance curve.
 The published closed valve head has a +6% tolerance.

Other specified duty points, including their tolerances, shall be per separate agreement between Peerless Pump Co. and buyer.

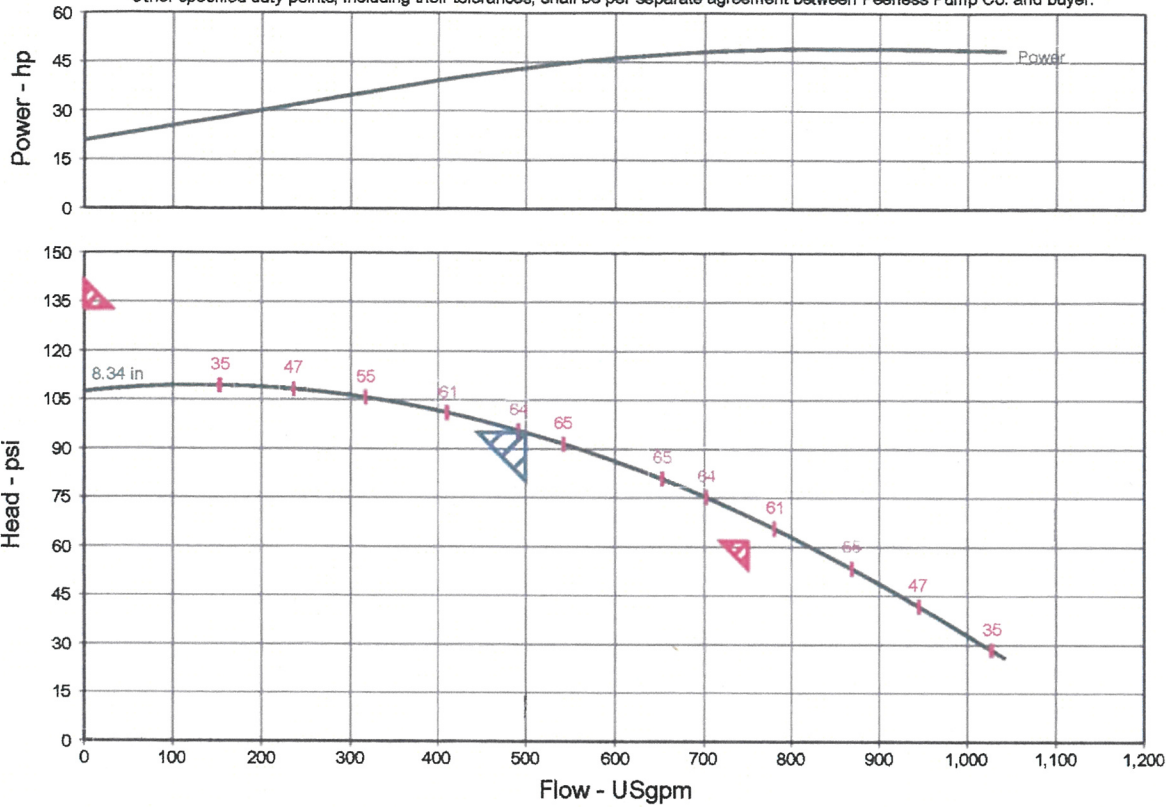

Customer	: Florida Keys Fire	Peerless Model	: 5PVF11
Customer ref. / PO	:	Stages	: 1
Tag Number	: 001	Speed, rated	: 3550 rpm
Service	:	Based on curve number	: 5PVF11-3550 Rev May 2019
Quantity	: 1	Efficiency	: 64.22 %
Quote Number / ID	: A-20348-F	Rated power (based on duty point)	: 43.1 hp
Date last saved	: 29 Mar 2023 1:57 PM	Max power (non-overloading)	: 49.2 hp
Flow, rated	: 500 USgpm	NPSH required	: -
Differential head / pressure, rated	: 95.00 psi	Viscosity	: 1.00 cP
Fluid density, rated / max	: 1.000 / 1.000 SG	Cq/Ch/Ce/Cn [ANSI/HI 9.6.7-2010]	: 1.00 / 1.00 / 1.00 / 1.00

Flow (USgpm)	Head (psi)	Efficiency (%)	Power (hp)	NPSHr (ft)	Thrust, total (lbf)
0	107.5	0.00	20.9	-	-
116	109.4	28.38	26.1	-	-
232	108.4	46.45	31.5	-	-
348	104.5	57.32	37.0	-	-
463	97.70	63.18	41.8	-	-
579	88.20	65.33	45.6	-	-
695	76.08	64.18	48.1	-	-
811	61.48	59.25	49.1	-	-
927	44.61	49.17	49.1	-	-
1,043	25.71	32.21	48.6	-	-



General Arrangement

Installing Contractor(s) To Install Equipment In Accordance With Latest Editions Of National Electric Code, Local Codes And NFPA Pamphlet No. 20 Applicable TO Fire Pump Installations.



Clearance Recommended To Remove Motor

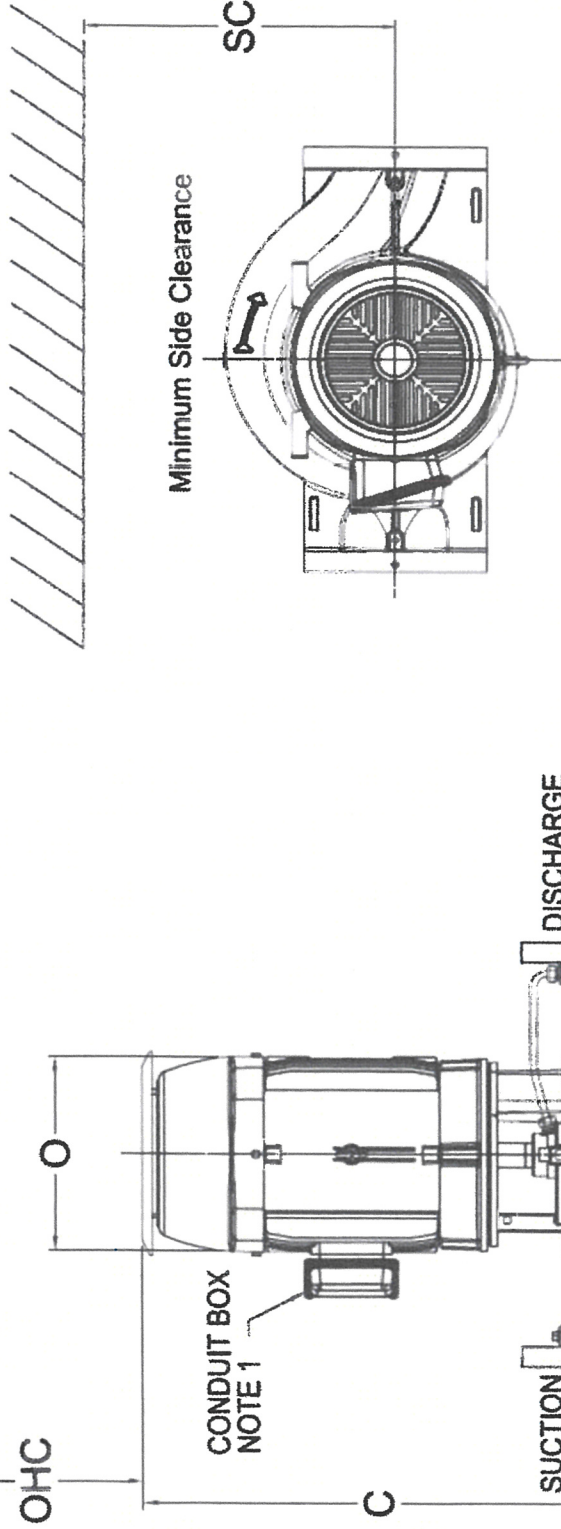

(H) = Diameter
(N) = # Of Holes
(HE) = Diameter Of Bolt Circle

NOTE 1
CONDUIT BOX IS
LOCATED 45 DEG FROM
SUCTION WHEN VIEWED
FROM TOP AND MAY
BE ROTATED IN 90 DEG
INCREMENTS

GENERAL	
Pump Model	SPVF-11
Listing / Approval	UL Listed
Rated Flow	500 USgpm
Liquid	Cold Water
Rated Pressure	95.00 psi
Specific Gravity	0.99824
Rated Speed	3550 rpm
MOTOR	
Manufacturer	WEG
Enclosure	ODP
Hp	50.0 hp
Frame	324JPV
Volt/Ph/Hz	460V / 3Ph / 60Hz
Service Factor	1.15
Customer	Florida Keys Fire
Quote No.	A-20348-F
Item No.	001
Project	Bight Marina Turtle Krawis
Date	03/29/2023

	HA	HG	Y	X	SC	Discharge	Suction
OHC	6.00 in	11.00 in	18.00 in	5.00 in		5.00 in	5.00 in
O	8.38 in	0.56 in	0.50 in				
C	41.00 in	11.63 in	4.00 in				
VD	9.81 in	11.62 in	9.88 in				



City of Key West Fire Pump Replacement

FIRE PUMP GENERAL NOTES

1. DESIGN, INSTALLATION & MATERIALS TO BE IN ACCORDANCE WITH NFPA 20, 2016 EDITION, INSTALLATION OF STATIONARY PUMPS FOR FIRE PROTECTION AND NFPA 13, 2016 EDITION, STANDARD FOR THE INSTALLATION OF SPRINKLER SYSTEMS.
2. ALL WIRING OF PANELS AND CONTROLLERS BY ELECTRICAL CONTRACTOR.
3. PIPE STANDS & HANGERS PROVIDED WHERE NECESSARY TO PROPERLY SUPPORT THE FIRE PUMP PIPING PER NFPA 20, 2016 EDITION.
4. ALL GROOVED FITTINGS TO BE STANDARD VICTAULIC FITTINGS WITH GROOVED COUPLINGS OR APPROVED EQUAL.
5. FIRE PUMP TO BE CITY APPROVED ELECTRICE PEERLESS FIRE PUMPS, U.L. LISTED AND F.M. APPROVED PER SPECIFICATIONS ATTACHED.
6. FIRE PUMP ACCEPTANCE TESTING, PERFORMANCE AND MAINTENANCE SHALL MEET THE REQUIREMENTS OF NFPA 20, 2016 EDITION CHAPTER 14.
7. ALL PIPE TO BE SCHEDULE 10 AND PAINTED REDF WITH NON-RUST PAINT.
8. REMOVE EXISTING FIRE PUMP AND INSTALL NEW FIRE PUMP WITHIN EXISTING LOCATION.LOCATION SHALL MEET ALL NFPA 20, 2016 EDITION AND LOCAL REQUIREMENTS.
9. THE FIRE PUMP CONTRACTOR SHALL PROVIDE SHOP DRAWINGS.
10. FIRE PUMP CONTRACTOR SHALL BE LICENSED BY THE CITY OF KEY WEST, ALONG WITH THE STATE OF FLORIDA AS A FIRE PROTECTION 1 CONTRACTOR.

City of Key West Fire Pump Replacement

SCOPE OF WORK

THIS SITE CONSISTS OF AN EXISTING ELECTRIC FIRE PUMP TO BE REMOVED AND NEW PEERLESS FIRE PUMP WILL BE INSTALLED ALONG WITH CONTROLLER, AS WELL AS JOCKEY PUMP AND CONTROLLER. SITE SUPPLIED BY AN EXISTING BACKFLOW.

PROVIDE AND INSTALL NEW PEERLESS ELECTRIC FIRE PUMP TO SUPPLY FIRE PROTECTION WATER TO THE EXISTING LOCATION AND ANY SPRINKLER SYSTEM THAT MAYBE PART OF SYSTEM. SEE ATTACHED PEERLESS FIRE PUMP DESCRIPTION, ALONG WITH EQUIPMENT ATTACHED.

THE EXISTING FIRE PUMP LOCATION IS TO REMAIN AND SHALL MEET NFPA 20 REQUIREMENTS.

FIRE DEPARTMENT CONNECTION SHALL BE INSTALLED, AS WELL AS SIGNAGE. THE FIRE PUMP IS SIZED TO MEET THE EXISTING CONDITIONS.

FIND ATTACHED COMPLETE REQUIREMENT AND SPECIFICATIONS FOR THE REPLACEMENT OF EXISTING FIRE PUMP AT THIS LOCATION.

PUMP #3

CITY MARINA @ GARRISON BIGHT - WEST



City of Key West			
Project name	City Marina at Garrison Bight	Quote Number / ID	A-20345-F
Customer	City of Key West	Model / Stages	5PVF7 / 1
Tag Number	West Side	Flow, rated	500 USgpm
Customer ref. / PO		Differential head / pressure, rated	70.00 psi
		Speed, rated	3520 rpm

Lead Time			
		Lead Time Total	8 wks

Pump	
Qty	Description
1	<p>5PVF7</p> <p>Fire Pump System</p> <p>Mount</p> <p>PumpType: New Pump</p> <p>Scope of Supply: Fire Pump with driver and controller</p> <p>Pump</p> <p>Pump model: 5PVF7</p> <p>Selected pump listing: FMUL Listed</p> <p>Casing material: Cast Iron</p> <p>Suction flange: 125lb ANSI Flat faced</p> <p>Discharge flange: 125lb ANSI Flat faced</p> <p>Impeller material: Silicon Brass</p> <p>Impeller Wear Ring: Integral</p> <p>Rotation: Clockwise (RH)</p> <p>Shaft material: Carbon steel</p> <p>Shaft sleeve material: Bronze with O-ring</p> <p>Packing type: Standard</p> <p>Nameplate units: US</p> <p>Coating: Standard Red Enamel</p> <p>Tests & Certifications</p> <p>Performance Tests</p> <p> Non-witnessed Performance Test</p> <p>Hydrostatic Pressure Tests</p> <p> Non-witnessed Hydrostatic Test</p> <p>Driver Type</p> <p>Motor Phase: 3 Phase</p>

Driver	
Qty	Description
1	<p>Fire Pump System</p> <p>Driver Type</p> <p>Motor supplied by: Standard factory motor</p> <p>Motor voltage: 230 V</p> <p>Frequency: 60 Hz</p> <p>Starting method: Direct-on-line (DOL)</p> <p>Motor enclosure: Open Drip Proof</p> <p>Motor efficiency: Any</p> <p>Motor manufacturer: All motors</p> <p>Motor: Motor-electric, 04036OP3EFP286JPV-W4 286JPV, 40hp, 230V, 60Hz, 3600 rpm WEG, IE2, 1.15</p>



Accessories

Qty	Description
1	<p>Jockey pump casing relief valve: None selected</p> <p>Casing relief valve: Valve, casing relief, ClaVal, 0.75", 20-300psi, Listing: UL/FM</p> <p>Gauge: -14InHg/290psi Suction, 0-300psi Discharge</p> <p>Hose valve head: 4", Grooved, 0-500USgpm, 400psi MWP, 2 outlets, Cla-Val</p> <p>Hose valve: Valve, hose angle, 2.5" NPT internal thread, National standard, 300psi MWP, Listing: UL/FM</p>

Controller

Qty	Description
1	<p>Controller brand: All manufacturers</p> <p>Controller voltage: 220-240 V</p> <p>Transfer switch: No</p> <p>Controller frequency: 60 Hz</p> <p>Direct Ship Controller: No</p> <p>Controller type: Tornatech GPA Full voltage across the line starter, 40-40hp, 220-240V, 60hz</p> <p>Enclosure: - NEMA 2</p> <p>Enclosure type: NEMA Type 2</p> <p>Withstand Ratings (Controller): - Standard (see manufacturer documentation for value)</p>

Jockey Pump

Qty	Description
1	<p>Jockey pump supply: Grundfos CR</p> <p>Frequency: 60 Hz</p> <p>Phase: Three</p> <p>Voltage: 230 V</p> <p>Flow rate: Flow rated: 5 USgpm</p> <p>Total discharge head: Total discharge head: 80.00 psi</p> <p>Direct Ship Jockey Pump: No</p> <p>Jockey pump selected: CR 1-7-3ph/0.75Hp 56CFr Duty point: 4USgpm, 86.6psi, Shutoff pressure: 86.6psi, 230V, Oval flange, HQQE Seal type</p> <p>Jockey pump companion flange kit: 250# Flange fitting set (CR1S/1/3/5)</p>

Jockey Pump Controller

Qty	Description
1	<p>Jockey pump controller required: Yes</p> <p>Manufacturer: Tornatech</p> <p>Voltage: 230-350 V</p> <p>Frequency: 60 Hz</p> <p>Direct ship jockey pump controller: No</p> <p>Jockey pump controller selected: Tornatech Controller JP3, Across the line starter, 0.75hp, 220-240V, 3Ph, 60hz</p> <p>Enclosure: - NEMA 2</p> <p>Enclosure type: NEMA Type 2</p> <p>Application options: - None</p>

Engineered Skid Package

Qty	Description
1	Engineered Packaged Skid: Not Required



Commercial

Qty	Description
1	Shipping Container: Standard Skid Incoterms 2020: FCA Freight Pre-paid and add Named Place:



Pump Performance Curve

Performance based on test acceptance - Hyd Inst 14.6 Unilateral (1U)
 The rated point is the only guaranteed point (within the specified HI grade) on the performance curve.
 The published closed valve head has a +6% tolerance.

Other specified duty points, including their tolerances, shall be per separate agreement between Peerless Pump Co. and buyer.

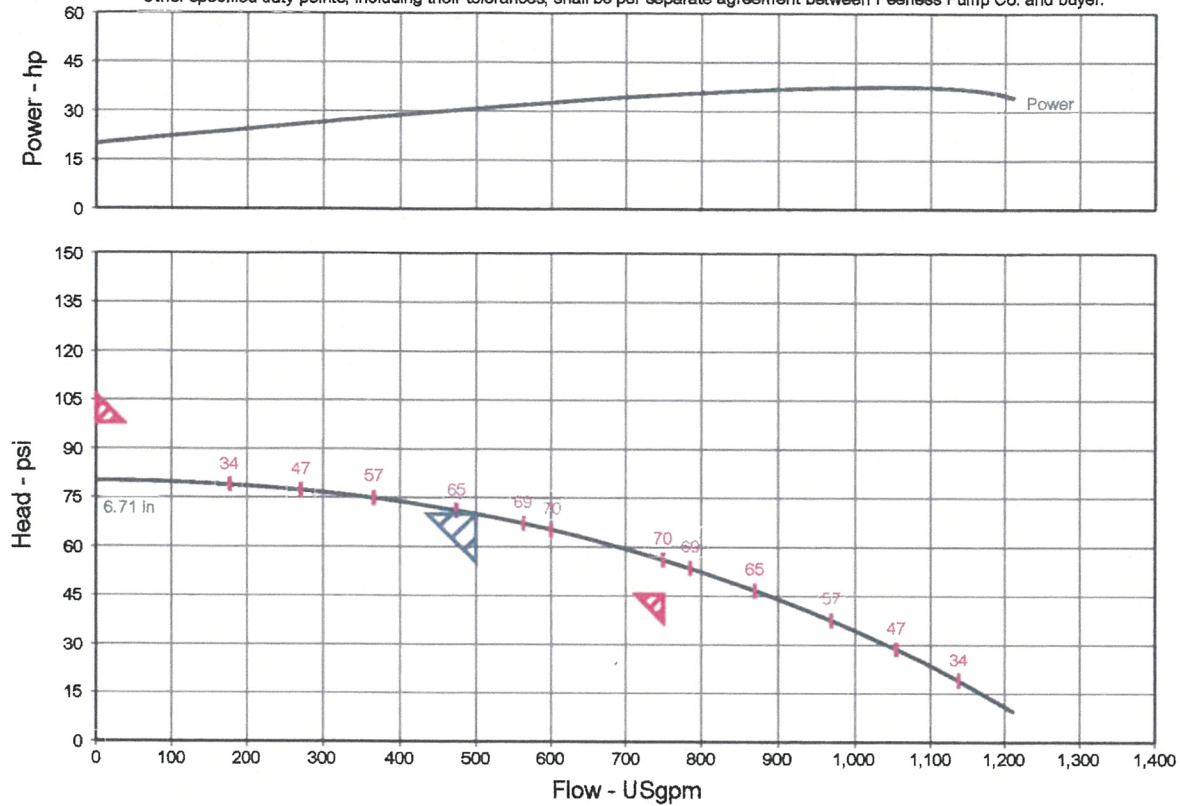

Customer	: Florida Keys Fire	Peerless Model	: 5PVF7
Customer ref. / PO	:	Stages	: 1
Tag Number	: Miami Subs side	Speed, rated	: 3520 rpm
Service	:	Based on curve number	: 5PVF7-3520 Rev OCT 2020
Quantity	: 1	Efficiency	: 66.40 %
Quote Number / ID	: A-20345-F	Rated power (based on duty point)	: 30.8 hp
Date last saved	: 29 Mar 2023 1:17 PM	Max power (non-overloading)	: 37.5 hp
Flow, rated	: 500 USgpm	NPSH required	: -
Differential head / pressure, rated	: 70.00 psi	Viscosity	: 1.00 cP
Fluid density, rated / max	: 1.000 / 1.000 SG	Cq/Ch/Ce/Cn [ANSI/HI 9.6.7-2010]	: 1.00 / 1.00 / 1.00 / 1.00

Flow (USgpm)	Head (psi)	Efficiency (%)	Power (hp)	NPSHr (ft)	Thrust, total (lbf)
0	80.17	0.00	20.1	-	-
135	79.42	27.16	23.0	-	-
269	77.31	46.83	26.0	-	-
404	73.67	60.24	28.8	-	-
539	68.31	68.14	31.5	-	-
674	61.05	70.83	33.9	-	-
808	51.70	68.14	35.8	-	-
943	40.08	59.45	37.1	-	-
1,078	26.02	43.66	37.5	-	-
1,213	9.31	19.25	34.2	-	-



General Arrangement

Installing Contractor(s) To Install Equipment In Accordance With Latest Editions Of National Electric Code, Local Codes And NFPA Pamphlet No. 20 Applicable TO Fire Pump Installations.



Clearance Recommended To Remove Motor

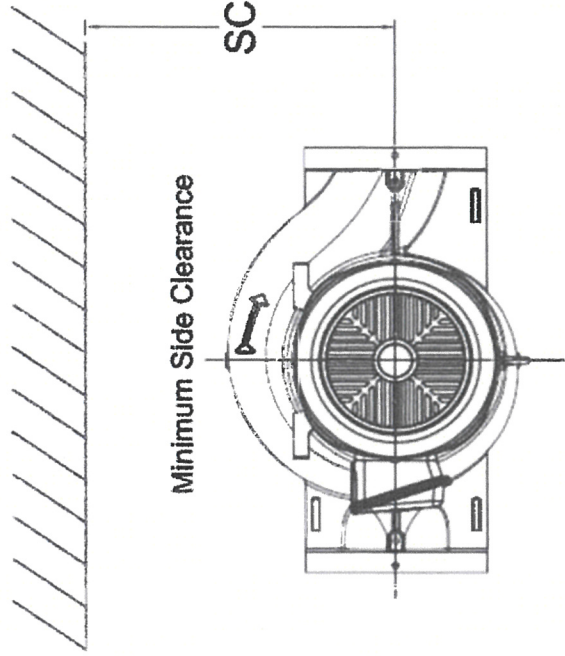
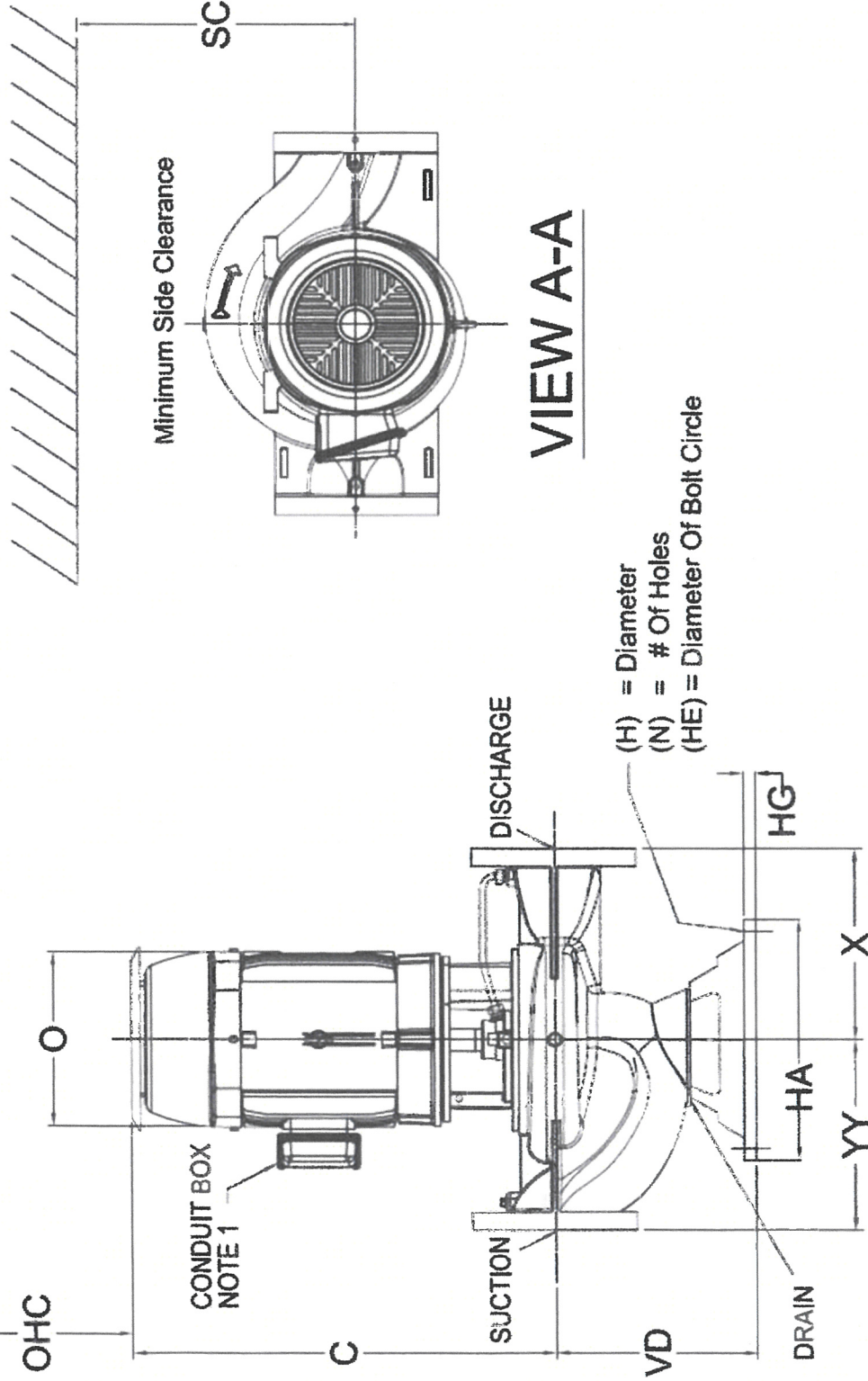

VIEW A-A

(H) = Diameter
(N) = # Of Holes
(HE) = Diameter Of Bolt Circle

NOTE 1
CONDUIT BOX IS LOCATED 45 DEG FROM SUCTION WHEN VIEWED FROM TOP AND MAY BE ROTATED IN 90 DEG INCREMENTS

GENERAL	
Pump Model	5PVF7
Listing / Approval	FM/UL Listed
Rated Flow	500 USgpm
Liquid	Cold Water
Rated Pressure	70.00 psi
Specific Gravity	0.99824
Rated speed	3520 rpm
MOTOR	
Manufacturer	WEG
Enclosure	ODP
Hp	40.0 hp
Frame	286JVP
Volt/Ph/Hz	230V / 3Ph / 60Hz
Service Factor	1.15
Customer	
Customer	Florida Keys Fire
Quote No.	A-20345-F
Item No.	Miami Subs side
Project	Garrison Bight Marina
Date	03/29/2023

OHC	22.00 in	HA	11.00 in	SC	18.00 in	Discharge	5.00 in
O	7.25 in	HG	0.56 in	H	0.50 in	Suction	5.00 in
C	40.00 in	YY	11.00 in	N	4.00 in		
VD	10.00 in	X	9.50 in	HE	9.88 in		



Customer Price Sheet Total Only			
Project name	City Marina at Garrison Bight	Quote Number / ID	A-20345-F
Customer	City of Key West	Model / Stages	5PVF7 / 1
Tag Number	West Side	Flow, rated	500 USgpm
Customer ref. / PO		Differential head / pressure, rated	70.00 psi
		Speed, rated	3520 rpm

Lead Time			
		Lead Time Total	8 wks

Pump	
Qty	Description
1	<p>5PVF7</p> <p>Fire Pump System</p> <p>Mount</p> <p>PumpType: New Pump</p> <p>Scope of Supply: Fire Pump with driver and controller</p> <p>Pump</p> <p>Pump model: 5PVF7</p> <p>Selected pump listing: FM/UL Listed</p> <p>Casing material: Cast Iron</p> <p>Suction flange: 125lb ANSI Flat faced</p> <p>Discharge flange: 125lb ANSI Flat faced</p> <p>Impeller material: Silicon Brass</p> <p>Impeller Wear Ring: Integral</p> <p>Rotation: Clockwise (RH)</p> <p>Shaft material: Carbon steel</p> <p>Shaft sleeve material: Bronze with O-ring</p> <p>Packing type: Standard</p> <p>Nameplate units: US</p> <p>Coating: Standard Red Enamel</p> <p>Tests & Certifications</p> <p>Performance Tests</p> <p> Non-witnessed Performance Test</p> <p>Hydrostatic Pressure Tests</p> <p> Non-witnessed Hydrostatic Test</p> <p>Driver Type</p> <p>Motor Phase: 3 Phase</p>

Driver	
Qty	Description
1	<p>Fire Pump System</p> <p>Driver Type</p> <p>Motor supplied by: Standard factory motor</p> <p>Motor voltage: 230 V</p> <p>Frequency: 60 Hz</p> <p>Starting method: Direct-on-line (DOL)</p> <p>Motor enclosure: Open Drip Proof</p> <p>Motor efficiency: Any</p> <p>Motor manufacturer: All motors</p> <p>Motor: Motor-electric, 04036OP3EFP286JPV-W4 286JPV, 40hp, 230V, 60Hz, 3600 rpm WEG, IE2, 1.15</p>



Accessories

Qty	Description
1	Jockey pump casing relief valve: None selected Casing relief valve: Valve, casing relief, ClaVal, 0.75", 20-300psi, Listing: UL/FM Gauge: -14InHg/290psi Suction, 0-300psi Discharge Hose valve head: 4", Grooved, 0-500USgpm, 400psi MWP, 2 outlets, Cla-Val Hose valve: Valve, hose angle, 2.5" NPT internal thread, National standard, 300psi MWP, Listing: UL/FM

Controller

Qty	Description
1	Controller brand: All manufacturers Controller voltage: 220-240 V Transfer switch: No Controller frequency: 60 Hz Direct Ship Controller: No Controller type: Tornatech GPA Full voltage across the line starter, 40-40hp, 220-240V, 60hz Enclosure: - NEMA 2 Enclosure type: NEMA Type 2 Withstand Ratings (Controller): - Standard (see manufacturer documentation for value)

Jockey Pump

Qty	Description
1	Jockey pump supply: Grundfos CR Frequency: 60 Hz Phase: Three Voltage: 230 V Flow rate: Flow rated: 5 USgpm Total discharge head: Total discharge head: 80.00 psi Direct Ship Jockey Pump: No Jockey pump selected: CR 1-7-3ph/0.75Hp 56CFr Duty point: 4USgpm, 86.6psi, Shutoff pressure: 86.6psi, 230V, Oval flange, HQQE Seal type Jockey pump companion flange kit: 250# Flange fitting set (CR1S/1/3/5)

Jockey Pump Controller

Qty	Description
1	Jockey pump controller required: Yes Manufacturer: Tomatech Voltage: 230-350 V Frequency: 60 Hz Direct ship jockey pump controller: No Jockey pump controller selected: Tomatech Controller JP3, Across the line starter, 0.75hp, 220-240V, 3Ph, 60hz Enclosure: - NEMA 2 Enclosure type: NEMA Type 2 Application options: - None

Engineered Skid Package

Qty	Description
1	Engineered Packaged Skid: Not Required



Commercial	
Qty	Description
1	Shipping Container: Standard Skid Incoterms 2020: FCA Freight Pre-paid and add Named Place:



Pump Performance Curve

Performance based on test acceptance - Hyd Inst 14.6 Unilateral (1U)
 The rated point is the only guaranteed point (within the specified HI grade) on the performance curve.
 The published closed valve head has a +6% tolerance.

Other specified duty points, including their tolerances, shall be per separate agreement between Peerless Pump Co. and buyer.

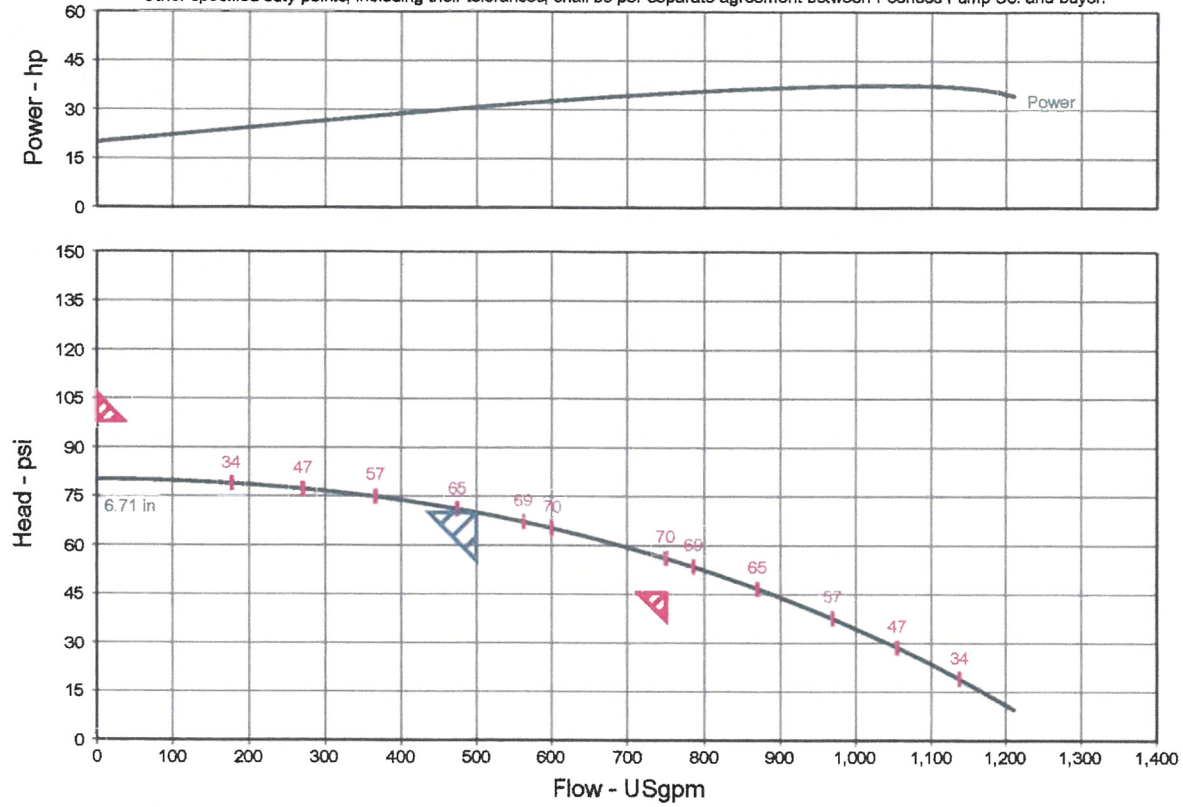

Customer	: Florida Keys Fire	Peerless Model	: 5PVF7
Customer ref. / PO	:	Stages	: 1
Tag Number	: Miami Subs side	Speed, rated	: 3520 rpm
Service	:	Based on curve number	: 5PVF7-3520 Rev OCT 2020
Quantity	: 1	Efficiency	: 66.40 %
Quote Number / ID	: A-20345-F	Rated power (based on duty point)	: 30.8 hp
Date last saved	: 29 Mar 2023 1:18 PM	Max power (non-overloading)	: 37.5 hp
Flow, rated	: 500 USgpm	NPSH required	: -
Differential head / pressure, rated	: 70.00 psi	Viscosity	: 1.00 cP
Fluid density, rated / max	: 1.000 / 1.000 SG	Cq/Ch/Ce/Cn [ANSI/HI 9.6.7-2010]	: 1.00 / 1.00 / 1.00 / 1.00

Flow (USgpm)	Head (psi)	Efficiency (%)	Power (hp)	NPSHr (ft)	Thrust, total (lbf)
0	80.17	0.00	20.1	-	-
135	79.42	27.16	23.0	-	-
269	77.31	46.83	26.0	-	-
404	73.67	60.24	28.8	-	-
539	68.31	68.14	31.5	-	-
674	61.05	70.83	33.9	-	-
808	51.70	68.14	35.8	-	-
943	40.08	59.45	37.1	-	-
1,078	26.02	43.66	37.5	-	-
1,213	9.31	19.25	34.2	-	-

General Arrangement

Installing Contractor(s) To Install Equipment in Accordance
With Latest Editions Of National Electric Code, Local Codes
And NFPA Pamphlet No. 20 Applicable TO Fire Pump
Installations.



Clearance Recommended To Remove Motor

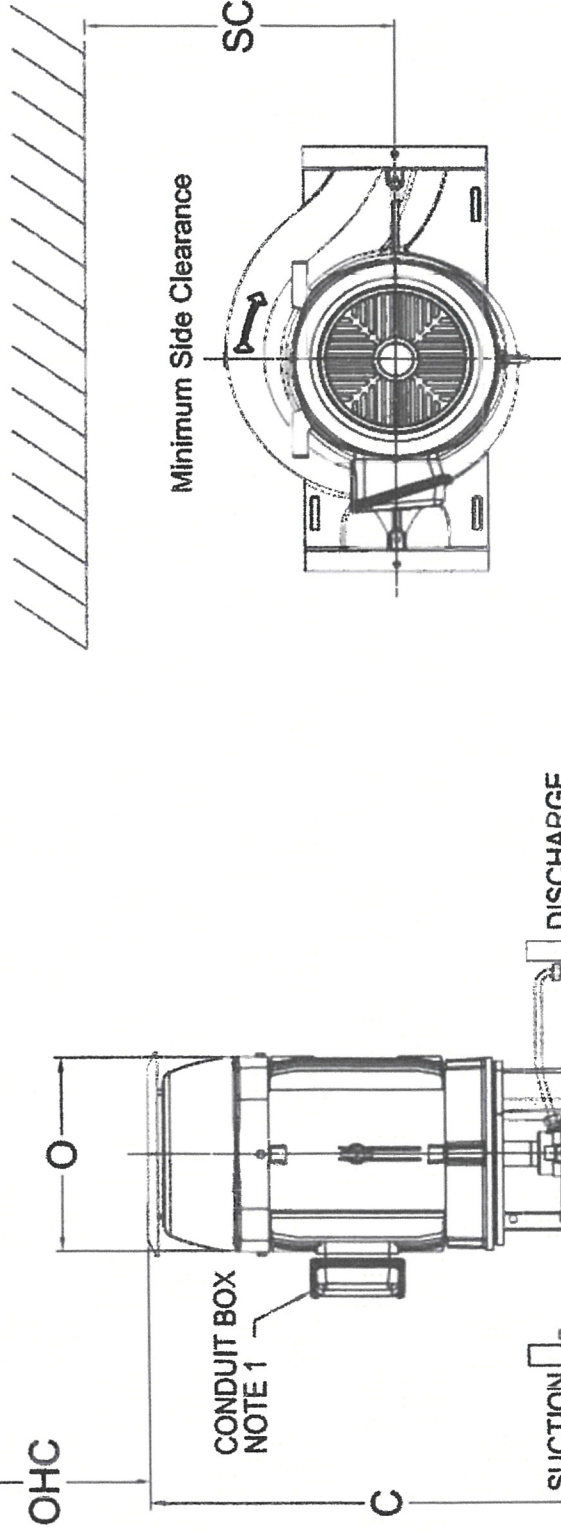

Minimum Side Clearance

VIEW A-A

(H) = Diameter
(N) = # Of Holes
(HE) = Diameter Of Bolt Circle

NOTE 1
CONDUIT BOX IS
LOCATED 45 DEG FROM
SUCTION WHEN VIEWED
FROM TOP AND MAY
BE ROTATED IN 90 DEG
INCREMENT

GENERAL	
Pump Model	5PVF7
Listing / Approval	FM/UL Listed
Rated Flow	500 USgpm
Liquid	Cold Water
Rated Pressure	70.00 psi
Specific Gravity	0.99824
Rated Speed	3520 rpm
MOTOR	
Manufacturer	WEG
Enclosure	ODP
Hp	40.0 hp
Frame	286JVP
Volt/Ph/Hz	230V / 3Ph / 60Hz
Service Factor	1.15
Customer	
Customer	Florida Keys
Quote No.	Fire
Item No.	A-20345-F
Project	Miami Subs side
Date	Garrison Bight Marina
	03/29/2023

Dimension	Value	Dimension	Value
OHC	22.00 in	SC	18.00 in
O	7.25 in	H	0.50 in
C	40.00 in	N	4.00 in
VD	10.00 in	HE	9.88 in
		Discharge	5.00 in
		Suction	5.00 in

City of Key West Fire Pump Replacement

FIRE PUMP GENERAL NOTES

1. DESIGN, INSTALLATION & MATERIALS TO BE IN ACCORDANCE WITH NFPA 20, 2016 EDITION, INSTALLATION OF STATIONARY PUMPS FOR FIRE PROTECTION AND NFPA 13, 2016 EDITION, STANDARD FOR THE INSTALLATION OF SPRINKLER SYSTEMS.
2. ALL WIRING OF PANELS AND CONTROLLERS BY ELECTRICAL CONTRACTOR.
3. PIPE STANDS & HANGERS PROVIDED WHERE NECESSARY TO PROPERLY SUPPORT THE FIRE PUMP PIPING PER NFPA 20, 2016 EDITION.
4. ALL GROOVED FITTINGS TO BE STANDARD VICTAULIC FITTINGS WITH GROOVED COUPLINGS OR APPROVED EQUAL.
5. FIRE PUMP TO BE CITY APPROVED ELECTRIC PEERLESS FIRE PUMPS, U.L. LISTED AND F.M. APPROVED PER SPECIFICATIONS ATTACHED.
6. FIRE PUMP ACCEPTANCE TESTING, PERFORMANCE AND MAINTENANCE SHALL MEET THE REQUIREMENTS OF NFPA 20, 2016 EDITION CHAPTER 14.
7. ALL PIPE TO BE SCHEDULE 10 AND PAINTED RED WITH NON-RUST PAINT.
8. REMOVE EXISTING FIRE PUMP AND INSTALL NEW FIRE PUMP WITHIN EXISTING LOCATION. LOCATION SHALL MEET ALL NFPA 20, 2016 EDITION AND LOCAL REQUIREMENTS.
9. THE FIRE PUMP CONTRACTOR SHALL PROVIDE SHOP DRAWINGS.
10. FIRE PUMP CONTRACTOR SHALL BE LICENSED BY THE CITY OF KEY WEST, ALONG WITH THE STATE OF FLORIDA AS A FIRE PROTECTION 1 CONTRACTOR.

City of Key West Fire Pump Replacement

SCOPE OF WORK

THIS SITE CONSISTS OF AN EXISTING ELECTRIC FIRE PUMP TO BE REMOVED AND NEW PEERLESS FIRE PUMP WILL BE INSTALLED ALONG WITH CONTROLLER, AS WELL AS JOCKEY PUMP AND CONTROLLER. SITE SUPPLIED BY AN EXISTING BACKFLOW.

PROVIDE AND INSTALL NEW PEERLESS ELECTRIC FIRE PUMP TO SUPPLY FIRE PROTECTION WATER TO THE EXISTING LOCATION AND ANY SPRINKLER SYSTEM THAT MAYBE PART OF SYSTEM. SEE ATTACHED PEERLESS FIRE PUMP DESCRIPTION, ALONG WITH EQUIPMENT ATTACHED.

THE EXISTING FIRE PUMP LOCATION IS TO REMAIN AND SHALL MEET NFPA 20 REQUIREMENTS.

FIRE DEPARTMENT CONNECTION SHALL BE INSTALLED, AS WELL AS SIGNAGE. THE FIRE PUMP IS SIZED TO MEET THE EXISTING CONDITIONS.

FIND ATTACHED COMPLETE REQUIREMENT AND SPECIFICATIONS FOR THE REPLACEMENT OF EXISTING FIRE PUMP AT THIS LOCATION.

PUMP #4

CITY MARINA @ GARRISON BIGHT - EAST



City of Key West

Project name	City Marina At Garrison Bight	Quote Number / ID	A-20345-F
Customer	City of Key West	Model / Stages	5PVF7 / 1
Tag Number	East Side	Flow, rated	500 USgpm
Customer ref. / PO		Differential head / pressure, rated	70.00 psi
		Speed, rated	3520 rpm

		Lead Time Total	8 wks
--	--	-----------------	-------

Pump

Qty	Description
1	<p>5PVF7</p> <p>Fire Pump System</p> <p>Mount</p> <p>PumpType: New Pump</p> <p>Scope of Supply: Fire Pump with driver and controller</p> <p>Pump</p> <p>Pump model: 5PVF7</p> <p>Selected pump listing: FM/UL Listed</p> <p>Casing material: Cast Iron</p> <p>Suction flange: 125lb ANSI Flat faced</p> <p>Discharge flange: 125lb ANSI Flat faced</p> <p>Impeller material: Silicon Brass</p> <p>Impeller Wear Ring: Integral</p> <p>Rotation: Clockwise (RH)</p> <p>Shaft material: Carbon steel</p> <p>Shaft sleeve material: Bronze with O-ring</p> <p>Packing type: Standard</p> <p>Nameplate units: US</p> <p>Coating: Standard Red Enamel</p> <p>Tests & Certifications</p> <p>Performance Tests</p> <p> Non-witnessed Performance Test</p> <p>Hydrostatic Pressure Tests</p> <p> Non-witnessed Hydrostatic Test</p> <p>Driver Type</p> <p>Motor Phase: 3 Phase</p>

Driver

Qty	Description
1	<p>Fire Pump System</p> <p>Driver Type</p> <p>Motor supplied by: Standard factory motor</p> <p>Motor voltage: 230 V</p> <p>Frequency: 60 Hz</p> <p>Starting method: Direct-on-line (DOL)</p> <p>Motor enclosure: Open Drip Proof</p> <p>Motor efficiency: Any</p> <p>Motor manufacturer: All motors</p> <p>Motor: Motor-electric, 04036OP3EFP286JPV-W4 286JPV, 40hp, 230V, 60Hz, 3600 rpm WEG, IE2, 1.15</p>



Accessories

Qty	Description
1	Jockey pump casing relief valve: None selected Casing relief valve: Valve, casing relief, ClaVal, 0.75", 20-300psi, Listing: UL/FM Gauge: -14InHg/290psi Suction, 0-300psi Discharge Hose valve head: 4", Grooved, 0-500USgpm, 400psi MWP, 2 outlets, Cla-Val Hose valve: Valve, hose angle, 2.5" NPT internal thread, National standard, 300psi MWP, Listing: UL/FM

Controller

Qty	Description
1	Controller brand: All manufacturers Controller voltage: 220-240 V Transfer switch: No Controller frequency: 60 Hz Direct Ship Controller: No Controller type: Tornatech GPA Full voltage across the line starter, 40-40hp, 220-240V, 60hz Enclosure: - NEMA 2 Enclosure type: NEMA Type 2 Withstand Ratings (Controller): - Standard (see manufacturer documentation for value)

Jockey Pump

Qty	Description
1	Jockey pump supply: Grundfos CR Frequency: 60 Hz Phase: Three Voltage: 230 V Flow rate: Flow rated: 5 USgpm Total discharge head: Total discharge head: 80.00 psi Direct Ship Jockey Pump: No Jockey pump selected: CR 1-7-3ph/0.75Hp 56CFr Duty point: 4USgpm, 86.6psi, Shutoff pressure: 86.6psi, 230V, Oval flange, HQQE Seal type Jockey pump companion flange kit: 250# Flange fitting set (CR1S/1/3/5)

Jockey Pump Controller

Qty	Description
1	Jockey pump controller required: Yes Manufacturer: Tornatech Voltage: 230-350 V Frequency: 60 Hz Direct ship jockey pump controller: No Jockey pump controller selected: Tornatech Controller JP3, Across the line starter, 0.75hp, 220-240V, 3Ph, 60hz Enclosure: - NEMA 2 Enclosure type: NEMA Type 2 Application options: - None

Engineered Skid Package

Qty	Description
1	Engineered Packaged Skid: Not Required



Commercial

Qty	Description
1	Shipping Container: Standard Skid Incoterms 2020: FCA Freight Pre-paid and add Named Place:



Pump Performance Curve

Performance based on test acceptance - Hyd Inst 14.6 Unilateral (1U)
 The rated point is the only guaranteed point (within the specified HI grade) on the performance curve.
 The published closed valve head has a +6% tolerance.

Other specified duty points, including their tolerances, shall be per separate agreement between Peerless Pump Co. and buyer.

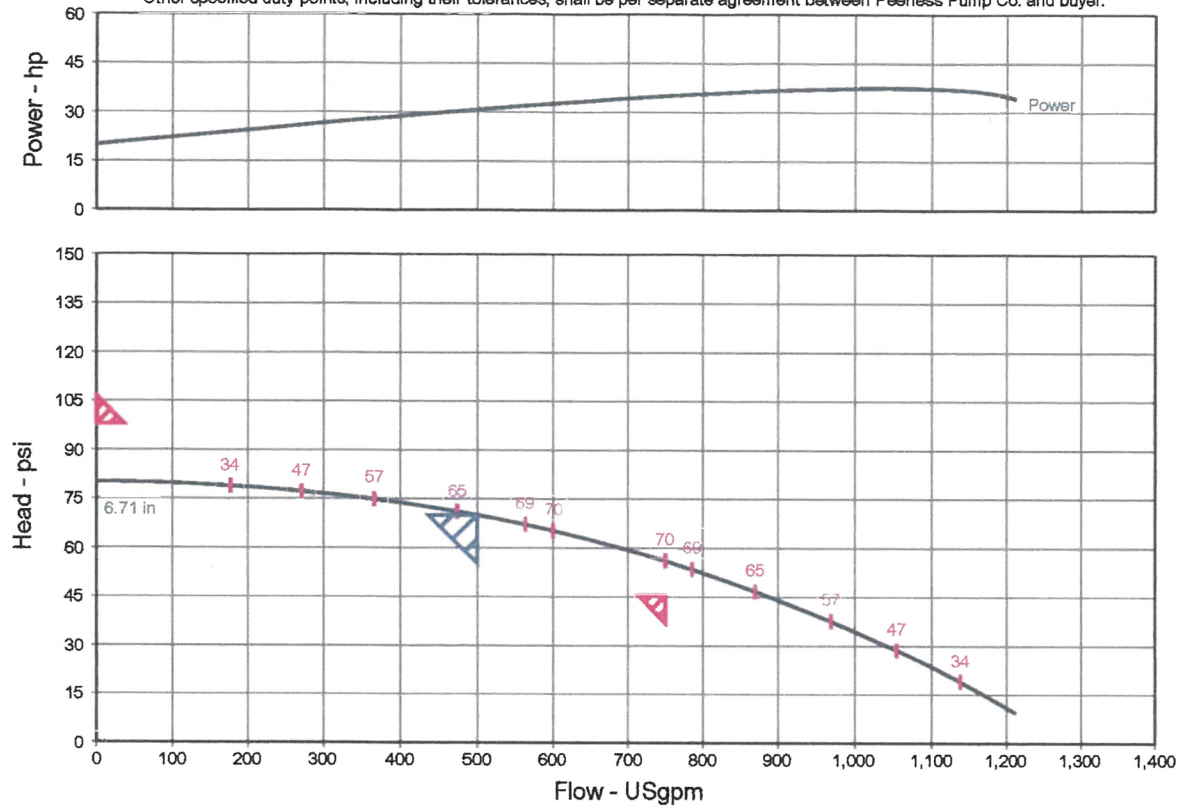

Customer	: Florida Keys Fire	Peerless Model	: 5PVF7
Customer ref. / PO	:	Stages	: 1
Tag Number	: Miami Subs side	Speed, rated	: 3520 rpm
Service	:	Based on curve number	: 5PVF7-3520 Rev OCT 2020
Quantity	: 1	Efficiency	: 66.40 %
Quote Number / ID	: A-20345-F	Rated power (based on duty point)	: 30.8 hp
Date last saved	: 29 Mar 2023 1:17 PM	Max power (non-overloading)	: 37.5 hp
Flow, rated	: 500 USgpm	NPSH required	: -
Differential head / pressure, rated	: 70.00 psi	Viscosity	: 1.00 cP
Fluid density, rated / max	: 1.000 / 1.000 SG	Cq/Ch/Ce/Cn [ANSI/HI 9.6.7-2010]	: 1.00 / 1.00 / 1.00 / 1.00

Flow (USgpm)	Head (psi)	Efficiency (%)	Power (hp)	NPSHr (ft)	Thrust, total (lbf)
0	80.17	0.00	20.1	-	-
135	79.42	27.16	23.0	-	-
269	77.31	46.83	26.0	-	-
404	73.67	60.24	28.8	-	-
539	68.31	68.14	31.5	-	-
674	61.05	70.83	33.9	-	-
808	51.70	68.14	35.8	-	-
943	40.08	59.45	37.1	-	-
1,078	26.02	43.66	37.5	-	-
1,213	9.31	19.25	34.2	-	-

General Arrangement General Arrangement

Installing Contractor(s) To Install Equipment In Accordance
With Latest Editions Of National Electric Code, Local Codes
And NFPA Pamphlet No. 20 Applicable TO Fire Pump
Installations.

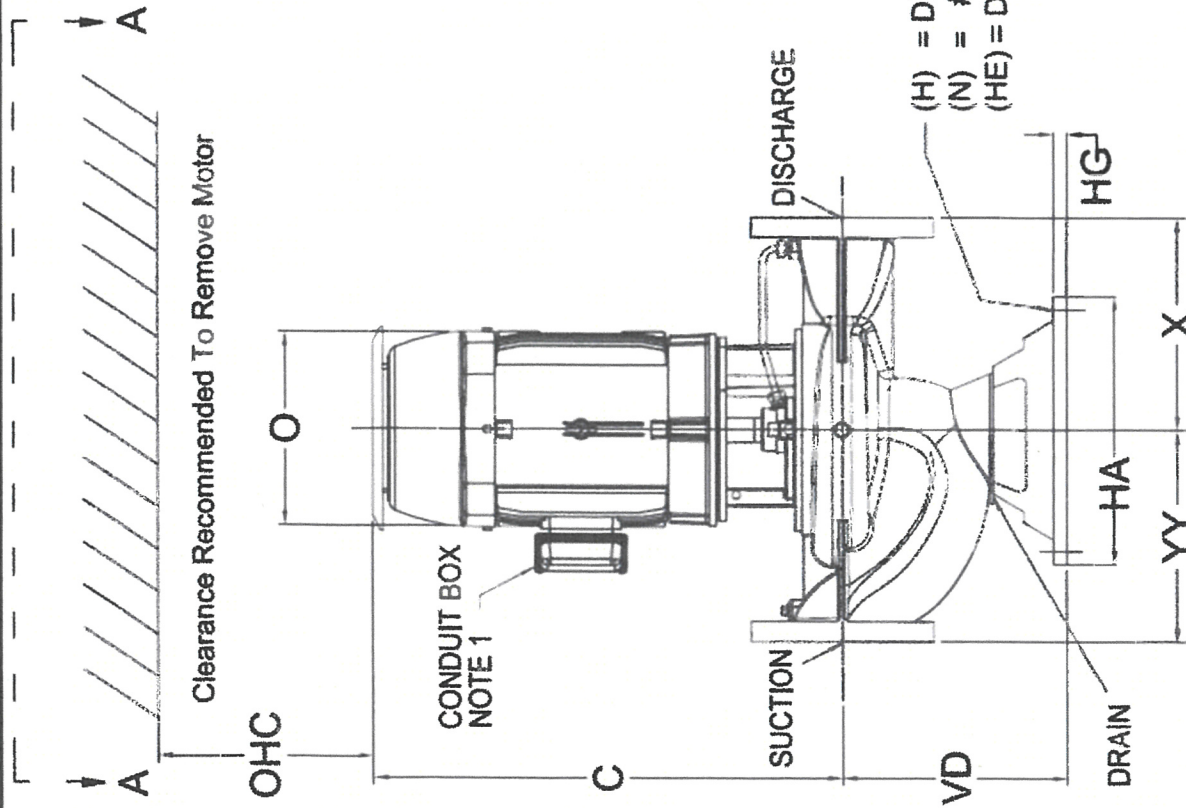

NOTE 1
CONDUIT BOX IS
LOCATED 45 DEG FROM
SUCTION WHEN VIEWED
FROM TOP AND MAY
BE ROTATED IN 90 DEG
INCREMENTS

GENERAL	
Pump Model	5PVF7
Listing / Approval	FM/UL Listed
Rated Flow	500 USgpm
Liquid	Cold Water
Rated Pressure	70.00 psi
Specific Gravity	0.99824
Rated Speed	3520 rpm
MOTOR	
Manufacturer	WEG
Enclosure	ODP
Hp	40.0 hp
Frame	286J/PV
Volt/Ph/Hz	230V / 3Ph / 60Hz
Service Factor	1.15
Customer	Florida Keys
Quote No.	A-20345-F
Item No.	Miami Subs side
Project	Garrison Bight Marina
Date	03/29/2023

OHC	22.00 in	HA	11.00 in	SC	18.00 in	Discharge	5.00 in
O	7.25 in	HG	0.56 in	H	0.50 in	Suction	5.00 in
C	40.00 in	YV	11.00 in	N	4.00 in		
VD	10.00 in	X	9.50 in	HE	9.88 in		



City of Key West			
Project name	City Marina at Garrison Bight	Quote Number / ID	A-20345-F
Customer	City of Key West	Model / Stages	5PVF7 / 1
Tag Number	West Side	Flow, rated	500 USgpm
Customer ref. / PO		Differential head / pressure, rated	70.00 psi
		Speed, rated	3520 rpm

Lead Time			
		Lead Time Total	8 wks

Pump	
Qty	Description
1	<p>5PVF7</p> <p>Fire Pump System</p> <p>Mount</p> <p>PumpType: New Pump</p> <p>Scope of Supply: Fire Pump with driver and controller</p> <p>Pump</p> <p>Pump model: 5PVF7</p> <p>Selected pump listing: FM/UL Listed</p> <p>Casing material: Cast Iron</p> <p>Suction flange: 125lb ANSI Flat faced</p> <p>Discharge flange: 125lb ANSI Flat faced</p> <p>Impeller material: Silicon Brass</p> <p>Impeller Wear Ring: Integral</p> <p>Rotation: Clockwise (RH)</p> <p>Shaft material: Carbon steel</p> <p>Shaft sleeve material: Bronze with O-ring</p> <p>Packing type: Standard</p> <p>Nameplate units: US</p> <p>Coating: Standard Red Enamel</p> <p>Tests & Certifications</p> <p>Performance Tests</p> <p> Non-witnessed Performance Test</p> <p>Hydrostatic Pressure Tests</p> <p> Non-witnessed Hydrostatic Test</p> <p>Driver Type</p> <p>Motor Phase: 3 Phase</p>

Driver	
Qty	Description
1	<p>Fire Pump System</p> <p>Driver Type</p> <p>Motor supplied by: Standard factory motor</p> <p>Motor voltage: 230 V</p> <p>Frequency: 60 Hz</p> <p>Starting method: Direct-on-line (DOL)</p> <p>Motor enclosure: Open Drip Proof</p> <p>Motor efficiency: Any</p> <p>Motor manufacturer: All motors</p> <p>Motor: Motor-electric, 04036OP3EFP286JPV-W4 286JPV, 40hp, 230V, 60Hz, 3600 rpm WEG, IE2, 1.15</p>



Accessories

Qty	Description
1	Jockey pump casing relief valve: None selected Casing relief valve: Valve, casing relief, ClaVal, 0.75", 20-300psi, Listing: UL/FM Gauge: -14InHg/290psi Suction, 0-300psi Discharge Hose valve head: 4", Grooved, 0-500USgpm, 400psi MWP, 2 outlets, Cla-Val Hose valve: Valve, hose angle, 2.5" NPT internal thread, National standard, 300psi MWP, Listing: UL/FM

Controller

Qty	Description
1	Controller brand: All manufacturers Controller voltage: 220-240 V Transfer switch: No Controller frequency: 60 Hz Direct Ship Controller: No Controller type: Tornatech GPA Full voltage across the line starter, 40-40hp, 220-240V, 60hz Enclosure: - NEMA 2 Enclosure type: NEMA Type 2 Withstand Ratings (Controller): - Standard (see manufacturer documentation for value)

Jockey Pump

Qty	Description
1	Jockey pump supply: Grundfos CR Frequency: 60 Hz Phase: Three Voltage: 230 V Flow rate: Flow rated: 5 USgpm Total discharge head: Total discharge head: 80.00 psi Direct Ship Jockey Pump: No Jockey pump selected: CR 1-7-3ph/0.75Hp 56CFr Duty point: 4USgpm, 86.6psi, Shutoff pressure: 86.6psi, 230V, Oval flange, HQQE Seal type Jockey pump companion flange kit: 250# Flange fitting set (CR1S/1/3/5)

Jockey Pump Controller

Qty	Description
1	Jockey pump controller required: Yes Manufacturer: Tornatech Voltage: 230-350 V Frequency: 60 Hz Direct ship jockey pump controller: No Jockey pump controller selected: Tornatech Controller JP3, Across the line starter, 0.75hp, 220-240V, 3Ph, 60hz Enclosure: - NEMA 2 Enclosure type: NEMA Type 2 Application options: - None

Engineered Skid Package

Qty	Description
1	Engineered Packaged Skid: Not Required



Commercial	
Qty	Description
1	Shipping Container: Standard Skid Incoterms 2020: FCA Freight Pre-paid and add Named Place:



Pump Performance Curve

Performance based on test acceptance - Hyd Inst 14.6 Unilateral (1U)
 The rated point is the only guaranteed point (within the specified HI grade) on the performance curve.
 The published closed valve head has a +6% tolerance.

Other specified duty points, including their tolerances, shall be per separate agreement between Peerless Pump Co. and buyer.

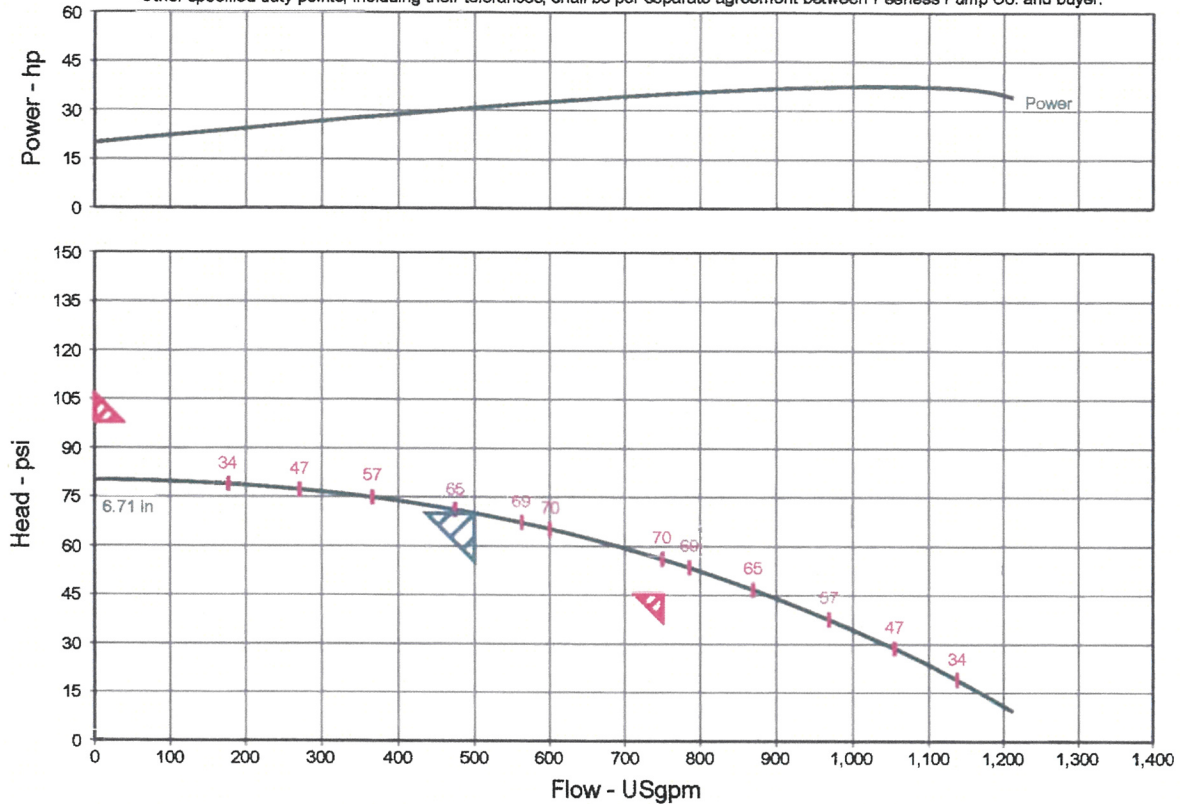

Customer	: Florida Keys Fire	Peerless Model	: 5PVF7
Customer ref. / PO	:	Stages	: 1
Tag Number	: Miami Subs side	Speed, rated	: 3520 rpm
Service	:	Based on curve number	: 5PVF7-3520 Rev OCT 2020
Quantity	: 1	Efficiency	: 66.40 %
Quote Number / ID	: A-20345-F	Rated power (based on duty point)	: 30.8 hp
Date last saved	: 29 Mar 2023 1:18 PM	Max power (non-overloading)	: 37.5 hp
Flow, rated	: 500 USgpm	NPSH required	: -
Differential head / pressure, rated	: 70.00 psi	Viscosity	: 1.00 cP
Fluid density, rated / max	: 1.000 / 1.000 SG	Cq/Ch/Ce/Cn [ANSI/HI 9.6.7-2010]	: 1.00 / 1.00 / 1.00 / 1.00

Flow (USgpm)	Head (psi)	Efficiency (%)	Power (hp)	NPSHr (ft)	Thrust, total (lbf)
0	80.17	0.00	20.1	-	-
135	79.42	27.16	23.0	-	-
269	77.31	46.83	26.0	-	-
404	73.67	60.24	28.8	-	-
539	68.31	68.14	31.5	-	-
674	61.05	70.83	33.9	-	-
808	51.70	68.14	35.8	-	-
943	40.08	59.45	37.1	-	-
1,078	26.02	43.66	37.5	-	-
1,213	9.31	19.25	34.2	-	-



General Arrangement

Installing Contractor(s) To Install Equipment In Accordance With Latest Editions Of National Electric Code, Local Codes And NFPA Pamphlet No. 20 Applicable TO Fire Pump Installations.

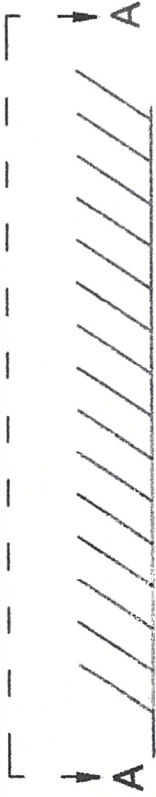

Clearance Recommended To Remove Motor

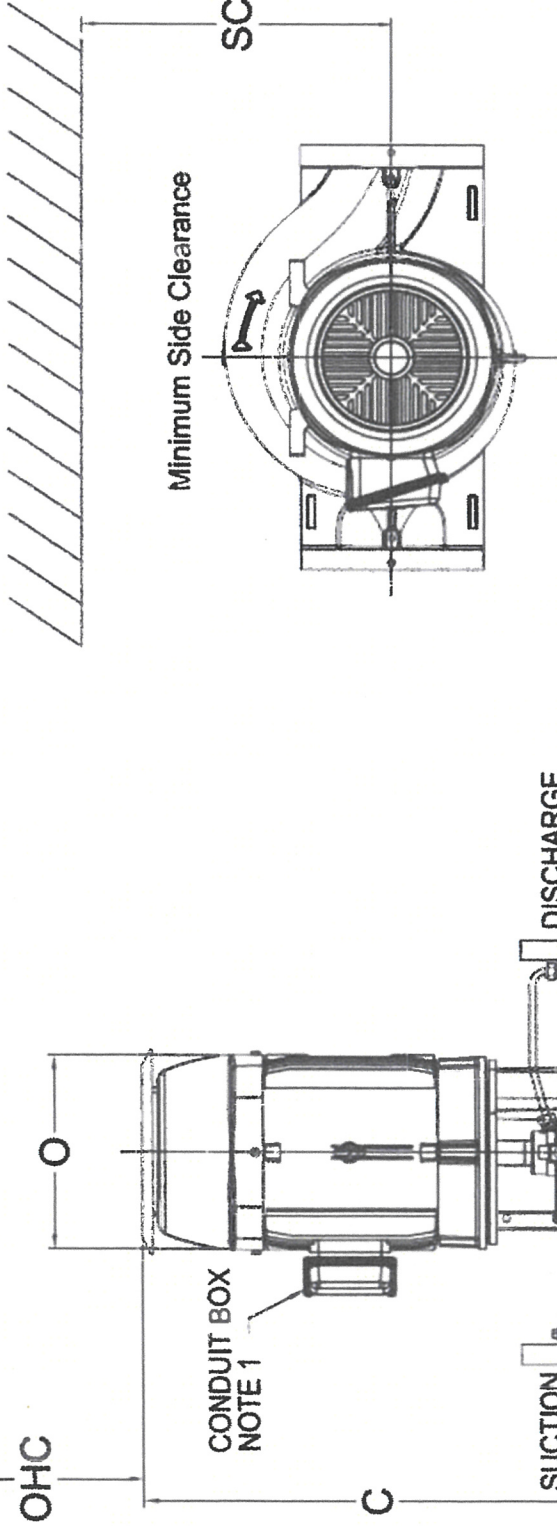

(H) = Diameter
(N) = # Of Holes
(HE) = Diameter Of Bolt Circle

NOTE 1
CONDUIT BOX IS LOCATED 45 DEG FROM SUCTION WHEN VIEWED FROM TOP AND MAY BE ROTATED IN 90 DEG INCREMENTS

GENERAL	
Pump Model	5PVF7
Listing / Approval	FM/UL Listed
Rated Flow	500 USgpm
Liquid	Cold Water
Rated Pressure	70.00 psi
Specific Gravity	0.99824
Rated Speed	3520 rpm
MOTOR	
Manufacturer	WEG
Enclosure	ODP
Hp	40.0 hp
Frame	286JPV
Volt/Ph/Hz	230V / 3Ph / 60Hz
Service Factor	1.15
Customer	
Customer	Florida Keys Fire
Quote No.	A-20345-F
Item No.	Miami Subs side
Project	Garrison Bight Marina
Date	03/29/2023

OHC	22.00 in	HA	11.00 in	SC	18.00 in	Discharge	5.00 in
O	7.25 in	HG	0.56 in	H	0.50 in	Suction	5.00 in
C	40.00 in	YY	11.00 in	N	4.00 in		
VD	10.00 in	X	9.50 in	HE	9.88 in		



City of Key West Fire Pump Replacement

SCOPE OF WORK

THIS SITE CONSISTS OF AN EXISTING ELECTRIC FIRE PUMP TO BE REMOVED AND NEW PEERLESS FIRE PUMP WILL BE INSTALLED ALONG WITH CONTROLLER, AS WELL AS JOCKEY PUMP AND CONTROLLER. SITE SUPPLIED BY AN EXISTING BACKFLOW.

PROVIDE AND INSTALL NEW PEERLESS ELECTRIC FIRE PUMP TO SUPPLY FIRE PROTECTION WATER TO THE EXISTING LOCATION AND ANY SPRINKLER SYSTEM THAT MAYBE PART OF SYSTEM. SEE ATTACHED PEERLESS FIRE PUMP DESCRIPTION, ALONG WITH EQUIPMENT ATTACHED.

THE EXISTING FIRE PUMP LOCATION IS TO REMAIN AND SHALL MEET NFPA 20 REQUIREMENTS.

FIRE DEPARTMENT CONNECTION SHALL BE INSTALLED, AS WELL AS SIGNAGE. THE FIRE PUMP IS SIZED TO MEET THE EXISTING CONDITIONS.

FIND ATTACHED COMPLETE REQUIREMENT AND SPECIFICATIONS FOR THE REPLACEMENT OF EXISTING FIRE PUMP AT THIS LOCATION.

City of Key West Fire Pump Replacement

FIRE PUMP GENERAL NOTES

1. DESIGN, INSTALLATION & MATERIALS TO BE IN ACCORDANCE WITH NFPA 20, 2016 EDITION, INSTALLATION OF STATIONARY PUMPS FOR FIRE PROTECTION AND NFPA 13, 2016 EDITION, STANDARD FOR THE INSTALLATION OF SPRINKLER SYSTEMS.
2. ALL WIRING OF PANELS AND CONTROLLERS BY ELECTRICAL CONTRACTOR.
3. PIPE STANDS & HANGERS PROVIDED WHERE NECESSARY TO PROPERLY SUPPORT THE FIRE PUMP PIPING PER NFPA 20, 2016 EDITION.
4. ALL GROOVED FITTINGS TO BE STANDARD VICTAULIC FITTINGS WITH GROOVED COUPLINGS OR APPROVED EQUAL.
5. FIRE PUMP TO BE CITY APPROVED ELECTRIC PEERLESS FIRE PUMPS, U.L. LISTED AND F.M. APPROVED PER SPECIFICATIONS ATTACHED.
6. FIRE PUMP ACCEPTANCE TESTING, PERFORMANCE AND MAINTENANCE SHALL MEET THE REQUIREMENTS OF NFPA 20, 2016 EDITION CHAPTER 14.
7. ALL PIPE TO BE SCHEDULE 10 AND PAINTED RED WITH NON-RUST PAINT.
8. REMOVE EXISTING FIRE PUMP AND INSTALL NEW FIRE PUMP WITHIN EXISTING LOCATION. LOCATION SHALL MEET ALL NFPA 20, 2016 EDITION AND LOCAL REQUIREMENTS.
9. THE FIRE PUMP CONTRACTOR SHALL PROVIDE SHOP DRAWINGS.
10. FIRE PUMP CONTRACTOR SHALL BE LICENSED BY THE CITY OF KEY WEST, ALONG WITH THE STATE OF FLORIDA AS A FIRE PROTECTION 1 CONTRACTOR.