

**PROPOSAL**

To: The City of Key West  
Address: 525 Angela Street, P.O. Box 1409  
Key West, Florida 33041  
Project Title: **College Road Enhancements  
Overseas Highway to Kokenzie Road**  
Project No.: GN- 0711

Bidder's person to contact for additional information on this Proposal:

Name: Ronald J Armstrong  
Telephone: 305 296 5606

**BIDDER'S DECLARATION AND UNDERSTANDING**

The undersigned, hereinafter called the Bidder, declares that the only persons or parties interested in this Proposal are those named herein, that this Proposal is, in all respects, fair and without fraud, that it is made without collusion with any official of the Owner, and that the Proposal is made without any connection or collusion with any person submitting another Proposal on this Contract.

The Bidder further declares that he has carefully examined the Contract Documents, that he has personally inspected the Project, that he has satisfied himself as to the quantities involved, including materials and equipment, and conditions of work involved, including the fact that the description of the quantities of work and materials, as included herein, is brief and is intended only to indicate the general nature of the work and to identify the said quantities with the detailed requirements of the Contract Documents, and that this Proposal is made according to the provisions and under the terms of the Contract Documents, which Documents are hereby made a part of this Proposal.

The Bidder further agrees that he has exercised his own judgment regarding the interpretation of subsurface information and has utilized all data which he believes pertinent from the Engineer, Owner, and other sources in arriving at his conclusions.

The Bidder further agrees, as evidenced by signing the Proposal, which if awarded a Contract, the Florida Trench Safety Act and applicable trench safety standards will be complied with.

The Bidder understands and agrees that if a Contract is awarded, the Owner may elect to award all schedules under one Contract, separately, or in any combination that best serves the interests of the Owner.

CONTRACT EXECUTION AND BONDS

The Bidder agrees that if this Proposal is accepted, he will, within 10 days, not including Sundays and legal holidays, after Notice of Award, sign the Contract in the form annexed hereto, and will at that time, deliver to the Owner examples of the Performance Bond and Payment Bond required herein, and evidence of holding required licenses and certificates, and will, to the extent of his Proposal, furnish all machinery, tools, apparatus, and other means of construction and do the work and furnish all the materials necessary to complete all work as specified or indicated in the Contract Documents.

CERTIFICATES OF INSURANCE

Bidder agrees to furnish the Owner, before commencing the work under this Contract, the certificates of insurance as specified in these Documents.

START OF CONSTRUCTION AND CONTRACT COMPLETION TIME

*The Bidder further agrees to begin work within 14 calendar days of the Notice to Proceed (NTP) and to complete the construction in all respects within 120 calendar days from the date of the NTP.*

LIQUIDATED DAMAGES

In the event the Bidder is awarded the Contract and fails to complete the work within the time limit or extended time limit agreed upon, as more particularly set forth in the Contract Documents, liquidated damages shall be paid to the Owner based on the current FDOT Standard Specifications Section 8-10 until the work has been satisfactorily completed as provided by the Contract Documents. Sundays and legal holidays shall be included in determining days in default. FDOT 8-10 Code requirements govern, and herewith made a part of the Contract.

Original Contract Amount	Daily Charge Per Calendar Day
\$50,000 and Under	\$313
Over \$50,000 but less than \$250,000	\$580
\$250,000 but less than \$500,000	\$715
\$500,000 but less than \$2,500,000	\$1,423
\$2,500,000 but less than \$5,000,000	\$2,121
\$5,000,000 but less than \$10,000,000	\$3,057

ADDENDA

The Bidder hereby acknowledges that he has received Addenda No's. 1, 1, \_\_\_\_\_, \_\_\_\_\_, \_\_\_\_\_ (Bidder shall insert No. of each Addendum received) and agrees that all addenda issued are hereby made part of the Contract Documents, and the Bidder further agrees that his Proposal(s) includes all impacts resulting from said addenda.

## SALES AND USE TAXES

The Bidder agrees that all federal, state, and local sales and use taxes are included in the stated bid prices for the work.

## UNIT PRICE ITEMS

The Bidder further proposes to accept as full payment for the work proposed herein the amounts computed under the provisions of the Contract Documents and based on the following unit price amounts, it being expressly understood that the unit prices are independent of the exact quantities involved. The Bidder agrees that the unit prices represent a true measure of the labor and materials required to perform the work, including all allowances for overhead and profit for each type and unit of work called for in these Contract Documents. The amounts shall be shown in both words and figures. In case of a discrepancy, the amount shown in words shall govern. Unit price line items may be deleted, reduced or increased as needed within the awarded contract price by the city.

## COLLEGE ROAD ENHANCEMENTS

### BID SCHEDULE

The Bidder further Proposes to accept as full payment for the work Proposed herein the amounts computed under the Provisions of the Contract Documents and based on the following unit Price amounts, it being expressly understood that the unit Prices are independent of the exact quantities involved. The Bidder agrees that the unit Prices represent a true measure of the labor and materials required to perform the work, including all allowances for overhead and Profit for each type and unit of work called for in these Contract Documents. The amounts shall be shown in both words and figures. In case of a discrepancy, the amount shown in words shall govern. . Unit price line items may be deleted, reduced or increased as needed within the awarded contract price by the city

<u>Item</u>	<u>Quant.</u>	<u>Unit</u>	<u>UP (Fig)</u>	<u>UP (Words)</u>	<u>Extended Total Amount</u>
1. Performance and Payment Bonds					
	1	LS	\$4,872.00	Four Thousand Eight Hundred Seventy Two - 00/100	\$ 4,872.00
2.) Mobilization / Demobilization, FDOT Grant Requirements, General & Supplementary Conditions, MOT, Certified AutoCAD As-Builts)					
a.) Mobilization / Field Engineering / Testing / Environmental / Construction layout/ pre -construction video (paid 25%, then on percentage of completion)					
	1	LS	\$12,500.00	Twelve Thousand Five Hundred Dollars - 00/100	\$ 12,500.00
b.) Demobilization (paid at completion of final punch list completion)					
	1	LS	\$6,250.00	Six Thousand Two Hundred Fifty Dollars - 00/100	\$ 6,250.00
c.) FDOT Grant Requirements, General & Supplementary Conditions, (paid 25%, then on percentage of completion)					
	1	LS	\$17,625.00	Seventeen Thousand Six Hundred Twenty Five Dollars - 00/100	\$ 17,625.00
d.) MOT, (paid 25%, then on percentage of completion)					
	1	LS	\$26,700.00	Twenty Six Thousand Seven Hundred Dollars - 00/100	\$ 26,700.00
e.) Certified AutoCAD As-Builts / Surveyor (paid after submission and acceptance of as-builts)					
	1	LS	\$4,375.00	Four Thousand Three Hundred Seventy Five Dollars - 00/100	\$ 4,375.00

<u>Item</u>	<u>Quant.</u>	<u>Unit</u>	<u>UP (Fig)</u>	<u>UP (Words)</u>	<u>Extended Total Amount</u>
3). Clearing and Grubbing (to be paid for as described in the current FDOT Standards and Specifications, Section 110; includes cutting back grass growing over edge of pavement; includes tree/plant relocation or transplantation; includes pruning tree roots adjacent to roadway as required)					
	0.98	AC	\$ <u>11,352.04</u>	Eleven Thousand Three Hundred Fifty Two Dollars — 04/100	\$ <u>11,125.00</u>
4). Sidewalk Installation (material and labor to install; including excavation, backfill and compaction)					
a. 4" Depth (e.g. sidewalk throughout most of project)					
	974	SY	\$ <u>54.40</u>	Fifty Four Dollars — 40/100	\$ <u>52,985.60</u>
b. 6" Depth (e.g. sidewalk crossing driveways, 6' X 12' bus stop pads)					
	199	SY	\$ <u>76.99</u>	Seventy Six Dollars — 99/100	\$ <u>15,321.01</u>
c. Thickened Edge (sections of sidewalk / driveway without curbs and as directed)					
	3,362	LF	\$ <u>11.15</u>	Eleven Dollars — 15/100	\$ <u>37,486.30</u>
d. Bridged sidewalk over ditch bottom inlet (material and labor to install; including formwork required for 6" thick concrete)					
	5	CY	\$ <u>850.00</u>	Eight Hundred Fifty Dollars — 00/100	\$ <u>4,250.00</u>
5). Curb Installation (material and labor to install; including excavation, backfill and compaction)					
a. FDOT Type "F"					
	50	LF	\$ <u>43.75</u>	Forty Three Dollars — 75/100	\$ <u>2,187.50</u>
b. Flared end curb					
	1	EA	\$ <u>250.00</u>	Two Hundred Fifty Dollars — 00/100	\$ <u>250.00</u>
6). Guardrail (e.g. for section of sidewalk bridged over ditch bottom inlet)					
	35	LF	\$ <u>140.04</u>	One Hundred Forty Dollars — 04/100	\$ <u>4,901.40</u>
7). Asphalt/sp 9.5/1.5" (e.g. for incidental damage to sections of asphalt where sidewalk is formed close to edge of pavement and where 6" sidewalk crosses driveways)					
	50	SY	\$ <u>81.25</u>	Eighty One Dollars — 25/100	\$ <u>4,062.50</u>
8). Utility Adjustments (cost for complete installation, labor and materials)					
a. Adjust water valves / boxes (FKAA) vertically and/or laterally as required (complete cost for material and labor to adjust existing utility features as required)					
	3	EA	\$ <u>312.50</u>	Three Hundred Twelve Dollars — 50/100	\$ <u>937.50</u>

<u>Item</u>	<u>Quant.</u>	<u>Unit</u>	<u>UP (Fig)</u>	<u>UP (Words)</u>	<u>Extended Total Amount</u>
9). Silt Fence (e.g. for use behind back of proposed sidewalk at wetland area, as shown on plans)					
	415	LF	\$ <u>2.50</u>	Two Dollars - 50/100	\$ <u>1,037.50</u>
10). Plastic Delineators – flexible tubing (cost for complete installation, labor, and materials)					
	20	EA	\$ <u>75.00</u>	Seventy Five Dollars - 00/100	\$ <u>1,500.00</u>
11). ADAAG Detectable Warning System (2-1/4 x 4 x 8 Endicott Red Brick Pavers (cost for complete installation, labor, and materials)					
	12	<del>SX</del> SF	\$ <u>37.50</u>	Thirty Seven Dollars - 50/100	\$ <u>450.00</u>
12). Sodding (areas disturbed by construction activity -- replace with same material)					
	3200	SY	\$ <u>5.63</u>	Five Dollars - 63/100	\$ <u>18,016.00</u>
13). Remove Existing Trees/Shrubs (0-10" Diameter). Includes all Labor, Materials, Equipment and Maintenance, and Disposal / including city permit requirements					
	4	EA	\$ <u>250.00</u>	Two Hundred Fifty Dollars - 00/100	\$ <u>1,000.00</u>
14). Remove Existing Tree (over 10" Diameter) Includes all Labor, Materials, Equipment and Maintenance, and Disposal / including city permit requirements					
	2	EA	\$ <u>625.00</u>	Six Hundred Twenty Five Dollars - 00/100	\$ <u>1,250.00</u>
15). Business Sign relocation (Includes all Labor, Materials, and Equipment to remove and replace existing signs as directed by engineer)					
	3	EA	\$ <u>375.00</u>	Three Hundred Seventy Five Dollars - 00/100	\$ <u>1,125.00</u>
16). Allowance					
		LS	\$ <u>30,000</u>	Thirty thousand	\$ <u>30,000</u>

260,207.31

TOTAL OF ALL EXTENDED UNIT PRICE ITEMS LISTED ABOVE including allowance items

Two Hundred Sixty Thousand  
 \$ Two Hundred Seven Dollars Dollars and 31 Cents  
 (Amount Written in Words has Precedence)

**ADD/ALTS 1-4**

Add Alternates are not a part of the base bid and shall only be added to the contract at the owners discretion.

<u>Item</u>	<u>Quant.</u>	<u>Unit</u>	<u>UP (Fig)</u>	<u>UP (Words)</u>	<u>Extended Total Amount</u>
1). Seepage Trench	100	LF	\$ 87.75	Eighty Seven Dollars - 75/100	\$ 8,775.00
2). Striping (White retro-reflective 6", as required)	0.6	NM	\$ 8,392.80	Eight Thousand Three Hundred	\$ 5,035.68
3). Bus Shelters	2	EA	\$ 8,728.13	Ninety Two Dollars - 80/100 Eight Thousand Seven Hundred Twenty Eight Dollars - 13/100	\$ 17,456.26
4). Gravel Stone, 1/2 inch to 3/4 inch diameter (includes cost of material and labor to excavate 6" deep shoulder, grade bottom of shoulder, and backfill. Gravel will be for use in specified areas between edge of pavement and front of sidewalk as directed by the engineer).	65	TONS	\$ 89.60	Eighty Nine Dollars - 60/100	\$ 5,824.00

\$ 37,090.94

**TOTAL OF ADD/ALT UNIT PRICE ITEMS LISTED ABOVE**

\$ Thirty Seven Thousand Ninety Dollars Dollars and 94 Cents  
 (Amount Written in Words has Precedence)

List items to be performed by Contractor's own forces and the estimated total cost of these items.  
(Use additional sheets if necessary.)

All work except Asphalt. 95%



SUBCONTRACTORS

The Bidder further proposes that the following subcontracting firms or businesses will be awarded subcontracts for the following portions of the work in the event that the Bidder is awarded the Contract:

Note to Bidder: Subcontractors shall be prequalified to perform projects for FDOT.

Asphalt  
Portion of Work  
Bee Bros Development, Inc.  
Name  
8362 Pines Blvd Ste 258  
Pembroke Pines, FL 33024  
Street City State Zip

Portion of Work

Name

Street City State Zip

Portion of Work

Name

Street City State Zip

Portion of Work

Name

Street City State Zip

SURETY

The Hanover Insurance Co whose address is  
440 Lincoln St, Worcester, MA, 01653  
Street City State Zip

BIDDER

The name of the Bidder submitting this Proposal is

**CHARLEY TOPPINO & SONS, INC.** doing business at  
P.O. Box 787 Key West, FL, 33041  
Street City State Zip

which is the address to which all communications concerned with this Proposal and with the Contract shall be sent.

The names of the principal officers of the corporation submitting this Proposal, or of the partnership, or of all persons interested in this Proposal as principals are as follows:

Name	Title
<u>Frank P. Toppino</u>	<u>President</u>
<u>Edward Toppino, Sr</u>	<u>Secretary / Treasurer</u>
<u>Daniel P. Toppino</u>	<u>Assistant Secretary</u>
_____	_____
_____	_____

If Sole Proprietor or Partnership

IN WITNESS hereto ~~the undersigned~~ has set his (its) hand this \_\_\_\_\_ day of \_\_\_\_\_ 2011.

\_\_\_\_\_  
Signature of Bidder

\_\_\_\_\_  
Title

If Corporation

IN WITNESS WHEREOF the undersigned corporation has caused this instrument to be executed and its seal affixed by its duly authorized officers this 14 day of March 2011.

(SEAL)

**CHARLEY TOPPINO & SONS, INC.**

\_\_\_\_\_  
Name of Corporation

By Frank P. Joppuro

Title President

Attest D. J. Joppuro  
Secretary

EXPERIENCE OF BIDDER

The Bidder states that he is an experienced Contractor and has completed similar projects within the last 5 years.

(List similar projects, with types, names of owners, construction costs, Engineers, and references with phone numbers. Use additional sheets if necessary.)

See Attached

---

---

---

---

---

---

---

---

---

---

---

---

---

---

---

---

---

---

---

---

---

---

---

---

\*\*\*\*\*

# CHARLEY TOPPINO & SONS, INC.

P.O. BOX 787

KEY WEST, FL 33041

305 296-5606

## PAST PROJECTS

Please note: Frank P. Toppino and Edward Toppino, Sr., president and Secretary/Treasurer for CHARLEY TOPPINO & SONS, INC. has been involved, supervised, estimated and overseen the following projects. Paul E. Toppino and Edward Toppino, Jr. have also estimated and been involved in many of the following projects. Mr. Frank P. Toppino and Mr. Edward Toppino have been in the construction business for over 60 years each. Toppino's Inc., incorporated for 21 years, had its name change to CHARLEY TOPPINO & SONS, INC. 5 years ago.

### 1.) CITY OF KEY WEST

P.O. BOX 1409

KEY WEST, FL 33040

305 809-3965

**SCOPE OF WORK:** STORM DRAINAGE, INJECTIONS WELLS, SIDEWALKS, CURBS, FOUNDATIONS, PIER REPAIR, LANDSCAPING & MAINTENANCE, ROADWORK, ASPHALT.

### PROJECTS:

RIGHT OF WAY MAINTENANCE: 1998-2009	\$2,352,000	BOND YES
CONCRETE PLACEMENT- 2002, 2005, 2007	\$2,400,000	BOND YES
WHITE STREET PIER REPAIR	\$ 88,000	BOND YES
STAPLES AVE BRIDGE	\$ 81,000	BOND YES
HOCKEY RINK	\$ 50,000	BOND YES
KAMIEN SUBDIVISION	\$1,656,000	BOND YES
SOUTHERNMOST POINT REHABILITATION	\$ 73,000	BOND YES
GENERAL SERVICES CON. 1998---2000	\$4,000,000	BOND YES
GENERAL SERVICES CON. 2002, 2005	\$2,000,000	BOND YES
GENERAL SERVICES CON. 2007	\$2,000,000	BOND YES
GENERAL SERVICES CON. 2011	\$1,000,000	BOND YES
GRAVITY INJECTION WELLS: PHASE I	\$4,800,000	BOND YES
GRAVITY INJECTION WELLS: PHASE II	\$2,236,000	BOND YES
GRAVITY INJECTION WELLS: PHASE 5	\$1,998,385	BOND YES
GRAVITY INJECTION WELLS: PHASE 6	\$1,989,225	BOND YES
JOSE MARTI VEG REMOVAL / DRAINAGE	\$ 90,000	BOND NO
SMATHERS BEACH LANDSCAPING	\$ 100,000	BOND YES
DONALD AVE DRAINAGE SWALE	\$ 61,000	BOND NO
HURRICANE GEORGES CLEANUP	\$ 431,000	BOND NO
MITIGATION FLOW PROJECT	\$2,100,000	BOND YES
HARBOR WALK KW BIGHT	\$3,040,000	BOND YES
DINGY DOCKS 2001	\$ 104,000	BOND YES
WHITE ST PIER RIP RAP	\$ 131,054	BOND YES
FLAGLER AVE PHASE 1 & 2	\$1,391,000	BOND YES
WHITE ST PUMP STATION	\$1,645,000	BOND YES
SIDEWALK ENHANCEMENTS: PHASE 1	\$ 218,890	BOND YES
SIDEWALK ENHANCEMENTS: PHASE 2	\$ 164,181	BOND YES

SIDEWALK ENHANCEMENTS: PHASE 3      \$ 253,666      BOND YES

**2.) MONROE COUNTY**  
1100 SIMONTON STREET  
KEY WEST, FL 33040  
305 292-4426

**SCOPE OF WORK:** SITE WORK, STORM DRAINAGE, INJECTIONS WELLS, SIDEWALKS, CURBS, LANDSCAPING, ROADWORK, ASPHALT, PLAYGROUNDS.

**PROJECTS:**

PALM AVE ROADWAY	\$ 931,000	BOND YES
WILHELMINA PARK	\$ 145,000	BOND YES
MARATHON AIRPORT TAXILANES, T HANGER DEV.	\$2,366,000	BOND YES
MARATHON AIRPORT SERVICE ROAD	\$ 688,000	BOND YES
KW INTN AIRPORT: EXOTIC VEGETATION REMOVE	\$ 192,000	BOND YES
KW INTN AIRPORT: PARKING LOTS	\$ 531,000	BOND YES
BIG COPPITT PARK	\$ 860,242	BOND YES
BIG PINE BASIN FILL IN AND DEMO	\$ 904,943	BOND YES
MARATHON AIRPORT APRONS	\$ 376,344	BOND YES
PRADO CIRCLE	\$ 339,000	BOND YES
PALM DR BRIDGE REPAIR	\$ 131,000	BOND NO

**3.) FLORIDA DEPT OF TRANSPORTATION**  
605 Suwannee Street  
Tallahassee, FL 32399-0450  
(850) 414-4000

**SCOPE OF WORK:** SITE WORK, DEMOLITION, STORM DRAINAGE, SANITARY SEWER, INJECTIONS WELLS, SIDEWALKS, CURBS, ROADWORK, ASPHALT, HURRICANE CLEANUP, RIP-RAP INSTALL,

TRUMAN AVE PROJECT:	\$10,500,000	BOND YES
BIG COPPITT BIKE PATH:	\$ 480,000	BOND YES
EMERGENCY ROAD REPAIRS, HURR WILMA:	\$ 185,000	BOND NO
HURRICANE GEORGES ROAD REPAIRS:	\$ 52,000	BOND NO
KNIGHTS KEY	\$ 373,000	BOND YES
BIG COPPITT BOAT RAMP & SPANISH HARBOR:	\$ 500,000	BOND NO
BIKE PATH SADDLE BUNCH KEYS	\$ 450,000	BOND YES
BOCA CHICA SEAGRASS MITIGATION	\$ 1,352,930	BOND YES

**3.) SAUER INC.**  
11223 PHILLIPS PARKWAY DR EAST  
JACKSONVILLE, FL 32256-15274  
904 262-6444

**SCOPE OF WORK:** SITE WORK, DEMOLITION, STORM DRAINAGE, SANITARY SEWER, INJECTIONS WELLS, SIDEWALKS, CURBS, ROADWORK, ASPHALT.

**PROJECTS:**

CONTROL TOWER, BOCA CHICA NAS	\$832,000	BOND YES
WEATHER STATION, KEY WEST	\$366,000	BOND YES
NAVAL RESEARCH LAB	\$100,000	BOND NO
REPAIR MARINE OPS, COAST GUARD	\$337,000	BOND NO

**4.) FLORIDA KEY AQUADUCT AUTHORITY**  
1100 KENNEDY DRIVE  
KEY WEST, FL 33040  
305 296-2454

SCOPE OF WORK: SITE WORK, STORM DRAINAGE, SIDEWALKS, CURBS, ROADWORK, ASPHALT, STEEL BUILDING, WATER MAINS, DEMOLITION.

**PROJECTS:**

FCAA CONSTRUCTION YARD BUILDING	\$ 682,000	BOND YES
PUMP STATION	\$ 377,555	BOND YES
BIG COPPITT WASTE WATER SYSTEM	\$11,078,347	BOND YES
DEMO WATER TANKS, BIG COPPITT	\$ 55,000	BOND YES
FLAGLER AVE WATERMAIN	\$ 306,861	BOND YES

**5.) GULF BUILDERS**  
P.O. BOX 668307  
POMPANO BEACH, FL 33066  
954 583-5115

SCOPE OF WORK: SITE WORK, STORM DRAINAGE, SANITARY SEWER, WATER MAINS, INJECTIONS WELLS, SIDEWALKS, CURBS, ROADWORK, PARKING LOTS, ASPHALT.

**PROJECTS:**

ROOSEVELT GARDENS HOUSING PROJECT	\$1,256,000	BOND	YES
-----------------------------------	-------------	------	-----

**6.) BJ&K CONSTRUCTION**  
970 WEST MCNAB ROAD  
FORT LAUDERDALE, FL 33309  
954 974-7744

SCOPE OF WORK: SITE WORK, DEMOLITION, STORM DRAINAGE, SANITARY SEWER, WATER MAINS, INJECTIONS WELLS, SIDEWALKS, CURBS, ROADWORK, PARKING LOTS, ASPHALT.

**PROJECTS:**

MERIDIAN WEST APARTMENTS

\$1,700,000

BOND

YES

**7.) HEERY INTERNATIONAL**  
1625 DENNIS STREET  
KEY WEST, FL 33040  
305 293-3008

**SCOPE OF WORK:** SITE WORK, DEMOLITION, STORM DRAINAGE, SANITARY SEWER, WATER MAINS, INJECTIONS WELLS, GAS LINES, SIDEWALKS, CURBS, ROADWORK, PARKING LOTS, ASPHALT.

**PROJECTS:**

KEY WEST HIGH SCHOOL REPLACEMENT: PHASES 1, 2, 3	\$633,000	BOND	YES
POINCIANA ELEMENTARY SCHOOL:	\$2,240,000	BOND	YES

**8. COASTAL CONSTRUCTION**  
5959 BLUE LAGOON DR  
STE 200  
MIAMI, FL 33126  
305 559-4900

**SCOPE OF WORK:** SITE WORK, DEMOLITION, FILL, CONCRETE FLATWORK, COLUMNS, RETAINING WALLS, CURBS, ROADWORK, PARKING LOTS, ASPHALT.

**PROJECTS:**

SUGARLOAF ELEMENTARY SCHOOL:	\$2,300,000	BOND	YES
BEACHSIDE CONDOS	\$2,665,000	BOND	YES
POINCIANA ROYALE	\$ 524,520	BOND	YES

**9.) HISTORIC TOURS OF AMERICA**  
201 FRONT STREET  
Key West, Florida 33040  
305 296-3609

**SCOPE OF WORK:** SITE WORK, DEMOLITION, STORM DRAINAGE, SANITARY SEWER, WATER MAINS, INJECTIONS WELLS, GAS LINES, SIDEWALKS, CURBS, ROADWORK, PARKING LOTS, ASPHALT.

**PROJECTS:**

PARK VILLAGE	\$ 317,000	BOND	NO
MARQUESA COURT	\$ 405,000	BOND	NO
KEY COVE LANDINGS	\$ 675,000	BOND	NO



**10.) DEMOYA GROUP**  
12209 S. DIXIE HWY  
MIAMI, FL 33156  
305 255-5713

**SCOPE OF WORK:** STORM DRAINAGE , INJECTIONS WELLS, ROAD BASE, CONCRETE WORK.

**PROJECTS:**

SOUTH ROOSEVELT BLVD. REHAB	\$1,507,000.00	BOND NO (SUB)
BIG COPPITT US 1 ROAD EXPANSION	\$ 2,157,000	BOND NO (SUB)

**11.) DL PORTER**  
6574 PALMER CIRCLE  
SARASOTA, FL 34238  
941 929-9400

**SCOPE OF WORK:** SITE WORK, DEMOLITION, STORM DRAINAGE, SANITARY SEWER, WATER MAINS, INJECTIONS WELLS, GAS LINES, SIDEWALKS, CURBS, ROADWORK, PARKING LOTS, ASPHALT.

**PROJECTS:**

HOMELAND SECURITY, KEY WEST	\$ 231,600.00	BOND NO
KEY WEST INTERNATIONAL AIRPORT	\$ 724,000.00	BOND NO
SANTA MARIA HOTEL	\$ 225,000.00	BOND NO
COUCH HARBOR	\$ 210,000.00	BOND NO
ATLANTIC SHORES DEMO & SITEWORK	\$1,011,000.00	BOND NO
TRUMAN HOTEL SITEWORK	\$ 55,000.00	BOND NO

**12.) HARRY PEPPER & ASSOCIATES**  
215 CENTURY 21 DRIVE  
JACKSONVILLE, FL 32216  
904 721-3300

**SCOPE OF WORK:** SITE WORK, DEMOLITION, STORM DRAINAGE, SANITARY SEWER, WATER MAINS, INJECTIONS WELLS, GAS LINES, SIDEWALKS, CURBS, ROADWORK, PARKING LOTS, ASPHALT.

**PROJECTS:**

REPAIR BASE OPERATIONS, BOCA CHICA	\$601,000	BOND NO
ELLISON DRIVE, TRUMBO POINT	\$ 116,000	BOND NO
BEQ, TRUMAN ANNEX	\$ 70,000	BOND NO
JIAFT EAST WAREHOUSE	\$462,000	BOND NO

**13.) BRPH**  
3275 SUNTREE BLVD  
MELBOURNE, FL 32940

**SCOPE OF WORK:** SITE WORK, DEMOLITION, STORM DRAINAGE, SANITARY SEWER, WATER MAINS, INJECTIONS WELLS, GAS LINES, SIDEWALKS, CURBS, ROADWORK, PARKING LOTS, ASPHALT.

**PROJECTS:**

ECO DISCOVERY CENTER	\$ 50,000	BOND NO
BOCA CHICA FITNESS CENTER	\$ 36,000	BOND NO
MARINA BY PASS ROAD, BOCA	\$348,000	BOND NO
TACTS BUILDING, BOCA CHICA	\$ 32,000	BOND NO
NANCY FOSTER ENVIRONMENTAL CTR	\$541,000	BOND NO
BLDG. # 324 PARKING	\$93,000	BOND NO

**14. DOOLEY MACK CONTRACTORS**  
**5800 LAKEWOOD RANCH BLVD.**  
**SARASOTA, FL 34240**  
**941 921-4636**

**SCOPE OF WORK:** SITE WORK, DEMOLITION, STORM DRAINAGE, SANITARY SEWER, WATER MAINS, INJECTIONS WELLS, GAS LINES, SIDEWALKS, CURBS, ROADWORK, PARKING LOTS, ASPHALT.

STEAMPLANT CONDOS	\$1,332,000.00	BOND YES
THE MEADOWS, KEY WEST	\$ 145,000.00	BOND NO

**15. BOTANICAL GARDENS**  
**5210 COLLEGE ROAD**  
**KEY WEST, FL 33040**  
**305 296-1504**

**SCOPE OF WORK:** DEMOLITION, , SIDEWALKS, CURBS, ROADWORK, PARKING LOTS, BOARDWALK / PILE CONSTRUCTION, BOULDER CUTTING & PLACEMENT, LAKE / POND CONSTRUCTION.

BOTANICAL GARDENS PHASE 1 POND	\$329,896.50	BOND YES
BOTANICAL GARDENS PHASE III	\$167,000.00	BOND YES

**16. BALFOUR BEATTY MILITARY HOUSING MANAGEMENT LLC**  
**10 CAMPUS BLVD.**  
**NEWTOWN SQUARE, PA 19073**  
**610 355-8051**

**SCOPE OF WORK:** DEMOLITION, , SIDEWALKS, CURBS, ROADWORK, PARKING LOTS, BOARDWALK / PILE CONSTRUCTION, BOULDER CUTTING & PLACEMENT, LAKE / POND CONSTRUCTION.

RENOVATIONS FAMILY HOUSING MEDICAL CTR	\$141,350.00	BOND NO
RENOVATIONS TO QUARTERS LB, MEDICAL CTR	\$ 39,800.00	BOND NO

**17. FL DEPT OF ENVIRONMENTAL PROTECTION**  
**3900 COMMONWEALTH BLVD.**  
**TALLAHASSEE, FL 32399-3000**  
**305 420-8432**

**SCOPE OF WORK:** BRIDGE REPAIR TO OLD OHIO BAHIA HONDA BRIDGE, MM 38.7, REPAIR ENTIRE SUPER STRUCTURE DECK, PROVIDE AND INSTALL AL PEDESTRIAN RAILING, MILL/RESURFACE AND STRIPE, SPALL / CRACK REPAIR.

OHIO BAHIA HONDA BRIDGE REPAIR: \$837,700.00 BOND YES

**18. SH MARATHON, LTD.**  
**506 FLEMING ST.**  
**KEY WEST, FL 33040**  
**305 294-6100**

**SCOPE OF WORK:** DEMOLITION AND REBUILD OF HOTEL, RESTAURANT, MARINA AND BOAT SLIPS IN MARATHON, FL. HOLIDAY INN EXPRESS.

HOLIDAY INN EXPRESS: \$8,890,227 BOND YES

**19. DORADO/CONQUISTADOR**  
**541 N. PALMATTO AVE.**  
**SUITE 104**  
**SANFORD, FL 32771**  
**407 688-0600**

**SCOPE OF WORK:** SITEWORK, FILL REMOVAL AND PROCESSING AT THE BOCA CHICA NAVAL AIR STATION AIRFIELD.

BOCA CHICA AIRFIELD VEGETATION \$1,057,126.00 BOND YES

**20. SS RAFFERTY, LLC**  
**3717 EAGLE AVE**  
**KEY WEST, FL 33040**

**SCOPE OF WORK:** DEMOLITION, SITEWORK, BUILDING.

512 DUVAL STREET BUILDING \$1,071,586.28 BOND NO



WHEREAS, it was a condition precedent to the submission of said bid that a cashier's check, certified check, or bid bond in the amount of 5 percent of the base bid be submitted with said bid as a guarantee that the Bidder would, if awarded the Contract, enter into a written Contract with the Owner for the performance of said Contract, within 10 working days after written notice having been given of the award of the Contract.

NOW, THEREFORE, the conditions of this obligation are such that if the PRINCIPAL within 10 consecutive calendar days after written notice of such acceptance, enters into a written Contract with the OBLIGEE and furnishes the Performance and Payment Bonds, each in an amount equal to 100 percent of the base bid, satisfactory to the Owner, then this obligation shall be void; otherwise the sum herein stated shall be due and payable to the OBLIGEE and the Surety herein agrees to pay said sum immediately upon demand of the OBLIGEE in good and lawful money of the United States of America, as liquidated damages for failure thereof of said PRINCIPAL.

Signed and sealed this 3rd day of March, 2011.

PRINCIPAL Charley Toppino & Sons, Inc.

By Frank D. Toppino

SURETY The Hanover Insurance Company,

By [Signature]

Attorney-In-Fact  
William L. Parker, Attorney in Fact & FL Res Agent

\*\*\*\*\*

THE HANOVER INSURANCE COMPANY  
MASSACHUSETTS BAY INSURANCE COMPANY  
CITIZENS INSURANCE COMPANY OF AMERICA

POWERS OF ATTORNEY  
CERTIFIED COPY

KNOW ALL MEN BY THESE PRESENTS: That THE HANOVER INSURANCE COMPANY and MASSACHUSETTS BAY INSURANCE COMPANY, both being corporations organized and existing under the laws of the State of New Hampshire, and CITIZENS INSURANCE COMPANY OF AMERICA, a corporation organized and existing under the laws of the State of Michigan, do hereby constitute and appoint

Charles C. Ball, Ileana M. Bauza, William F. Klels, Davor I. Mimica and/or William L. Parker

of Miami, FL and each is a true and lawful Attorney(s)-in-fact to sign, execute, seal, acknowledge and deliver for, and on its behalf, and as its act and deed any place within the United States, or, if the following line be filled in, only within the area therein designated

any and all bonds, recognizances, undertakings, contracts of indemnity or other writings obligatory in the nature thereof, as follows:  
Any such obligations in the United States, not to exceed Twenty Million and No/100 (\$20,000,000) in any single instance

and said companies hereby ratify and confirm all and whatsoever said Attorney(s)-in-fact may lawfully do in the premises by virtue of these presents. These appointments are made under and by authority of the following Resolution passed by the Board of Directors of said Companies which resolutions are still in effect:

"RESOLVED, That the President or any Vice President, in conjunction with any Assistant Vice President, be and they are hereby authorized and empowered to appoint Attorneys-in-fact of the Company, in its name and as its acts, to execute and acknowledge for and on its behalf as Surety any and all bonds, recognizances, contracts of indemnity, waivers of citation and all other writings obligatory in the nature thereof, with power to attach thereto the seal of the Company. Any such writings so executed by such Attorneys-in-fact shall be as binding upon the Company as if they had been duly executed and acknowledged by the regularly elected officers of the Company in their own proper persons." (Adopted October 7, 1981 - The Hanover Insurance Company; Adopted April 14, 1982 - Massachusetts Bay Insurance Company; Adopted September 7, 2001 - Citizens Insurance Company of America)

IN WITNESS WHEREOF, THE HANOVER INSURANCE COMPANY, MASSACHUSETTS BAY INSURANCE COMPANY and CITIZENS INSURANCE COMPANY OF AMERICA have caused these presents to be sealed with their respective corporate seals, duly attested by a Vice President and an Assistant Vice President, this 8th day of July 2009.



THE HANOVER INSURANCE COMPANY  
MASSACHUSETTS BAY INSURANCE COMPANY  
CITIZENS INSURANCE COMPANY OF AMERICA

*Mary Jeanne Anderson*  
Mary Jeanne Anderson, Vice President

*Robert K. Grennan*  
Robert K. Grennan, Assistant Vice President

THE COMMONWEALTH OF MASSACHUSETTS )  
COUNTY OF WORCESTER ) ss.

On this 8th day of July 2009, before me came the above named Vice President and Assistant Vice President of The Hanover Insurance Company, Massachusetts Bay Insurance Company and Citizens Insurance Company of America, to me personally known to be the individuals and officers described herein, and acknowledged that the seals affixed to the preceding instrument are the corporate seals of The Hanover Insurance Company, Massachusetts Bay Insurance Company and Citizens Insurance Company of America, respectively, and that the said corporate seals and their signatures as officers were duly affixed and subscribed to said instrument by the authority and direction of said Corporations.

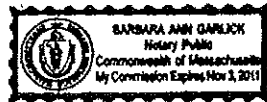

*Barbara A. Garlick*  
Notary Public

My commission expires on November 3, 2011

I, the undersigned Assistant Vice President of The Hanover Insurance Company, Massachusetts Bay Insurance Company and Citizens Insurance Company of America, hereby certify that the above and foregoing is a full, true and correct copy of the Original Power of Attorney issued by said Companies, and do hereby further certify that the said Powers of Attorney are still in force and effect.

This Certificate may be signed by facsimile under and by authority of the following resolution of the Board of Directors of The Hanover Insurance Company, Massachusetts Bay Insurance Company and Citizens Insurance Company of America.

"RESOLVED, That any and all Powers of Attorney and Certified Copies of such Powers of Attorney and certification in respect thereto, granted and executed by the President or any Vice President in conjunction with any Assistant Vice President of the Company, shall be binding on the Company to the same extent as if all signatures therein were manually affixed, even though one or more of any such signatures thereon may be facsimile." (Adopted October 7, 1981 - The Hanover Insurance Company; Adopted April 14, 1982 Massachusetts Bay Insurance Company; Adopted September 7, 2001 - Citizens Insurance Company of America)

GIVEN under my hand and the seals of said Companies, at Worcester, Massachusetts, this 3rd day of March, 2011

THE HANOVER INSURANCE COMPANY  
MASSACHUSETTS BAY INSURANCE COMPANY  
CITIZENS INSURANCE COMPANY OF AMERICA

*Stephen L. Breull*  
Stephen L. Breull, Assistant Vice President

ANTI-KICKBACK AFFIDAVIT

STATE OF FLORIDA

SS:

COUNTY OF MONROE

THIS FORM MUST BE SIGNED AND SWORN TO IN THE PRESENCE OF A NOTARY PUBLIC OR OTHER OFFICIAL AUTHORIZED TO ADMINISTER OATHS,

This sworn statement is submitted to the City of Key West, Florida, by Frank P. Toppino President (print individual's name and title)  
for CHARLEY TOPPINO & SONS, INC.  
(print name of entity submitting sworn statement)

whose business address is P.O. Box 287, Key West, FL 33041  
and (if applicable) its Federal Employer Identification Number (FEIN) is

592426906 (if the entity has no FEIN, include the Social Security Number of the individual signing this sworn statement):

I, the undersigned, being hereby duly sworn, depose and say that no sum has been paid and no sum will be paid to any employee or elected official of the City of Key West as a commission, kickback, reward or gift, directly or indirectly, by me or any member of my firm, or by any officer or agent of the corporation.

BY: Frank P. Toppino  
TITLE: President

sworn and prescribed before me this 14 day of 3, 2011

Ronald J. Armstrong  
NOTARY PUBLIC, State of Florida  
My commission expires:

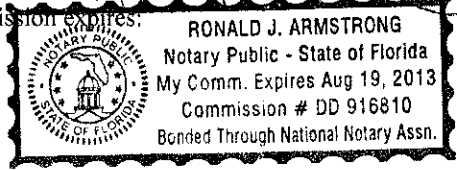

PUBLIC ENTITY CRIMES CERTIFICATION

THIS FORM MUST BE SIGNED AND SWORN TO IN THE PRESENCE OF A NOTARY PUBLIC OR OTHER OFFICIAL AUTHORIZED TO ADMINISTER OATHS,

1. This sworn statement is submitted to the City of Key West, Florida, by Frank P. Toppino President (print individual's name and title) for CHARLEY TOPPINO & SONS, INC. (print name of entity submitting sworn statement) whose business address is P.O. Box 7907 Key West, FL 33041 and (if applicable) its Federal Employer Identification Number (FEIN) is 59 2426 906 (If the entity has no FEIN, include the Social Security Number of the individual signing this sworn statement \_\_\_\_\_):

2. I understand that a "public entity crime" as defined in Paragraph 287.133(1)(g), Florida Statutes, means a violation of any state or federal law by a person with respect to and \_\_\_\_\_ directly related to the transaction of business with any public entity or with an agency or political subdivision of any other state or of the United States, including, but not limited to, any bid or contract for goods or services to be provided to any public entity or an agency or political subdivision of any other state or of the United States and involving antitrust, fraud, theft, bribery, collusion, racketeering, conspiracy, or material misrepresentation.

3. I understand that "conviction" as defined in Paragraph 287.133(1)(g), Florida Statutes, means a finding of guilt or a conviction of a public entity crime, with or without an adjudication of guilt, in any federal or state trial court of record relating to charges brought by indictment or information after July 1, 1989, as a result of a jury verdict, nonjury trial, or entry of a plea of guilty or nolo contendere.

4. I understand that an "affiliate" as defined in Paragraph 287.133(1)(a), Florida Statutes, means:

1. A predecessor or successor of a person convicted of a public entity crime: or
2. An entity under the control of any natural person who is active in the management of the entity and who has been convicted of a public entity crime. The term "affiliate" includes those officers, directors, executives, partners, shareholders, employees, members and agents who are active in the management of an affiliate. The ownership by one person of shares constituting a controlling interest in another person, \_\_\_\_\_ or a pooling of equipment of income among persons when not for fair market value under an arm's length agreement, shall be a prima facie case that one person controls another person. A person who knowingly enters into a joint venture with a person who has been convicted of a public entity crime in Florida during the preceding 36 months shall be considered an affiliate.

5. I understand that a "person" as defined in Paragraph 287.133(1)(e), Florida Statutes, means any natural person or entity organized under the laws of any state or of the United States with the legal power to enter into a binding contract and which bids or applies to bid on contracts for the provision of goods or services let by a public entity, or which otherwise transacts or applies to transact business with a public entity. The term "person" includes those officers, directors, executives, partners, shareholders, employees, members, and agents who are active in management of an entity.

6. Based on information and belief, the statement which I have marked below is true in relation to the entity submitting this sworn statement (indicate which statement applies).

Neither the entity submitting this sworn statement, or any of its officers, directors, executives, partners, shareholders, employees, members, or agents who are active in the management of the entity, nor any affiliate of the entity has been charged with and convicted of a public entity crime subsequent to July 1, 1989.



\_\_\_ The entity submitting this sworn statement, or one or more of its officers, directors, executives, partners, shareholders, employees, members, or agents who are active in the management of the entity, or an affiliate of the entity has been charged with and convicted of a public entity crime subsequent to July 1, 1989.

\_\_\_ The entity submitting this sworn statement, or one or more of its officers, directors, executives, partners, shareholders, employees, members, or agents who are active in the management of the entity, or an affiliate of the entity has been charged with and convicted of a public entity crime subsequent to July 1, 1989. However, there has been a subsequent proceeding before an Administrative Law Judge of the State of Florida, Division of Administrative Hearings and the Final Order entered by the Administrative Law Judge determined that it was not in the public interest to place the entity submitting this sworn statement on the convicted vendor list. (attach a copy of the final order)

I UNDERSTAND THAT THE SUBMISSION OF THIS FORM TO THE CONTRACTING OFFICER FOR THE PUBLIC ENTITY IDENTIFIED IN PARAGRAPH ONE (1) ABOVE IS FOR THAT PUBLIC ENTITY ONLY AND, THAT THIS FORM IS VALID THROUGH DECEMBER 31 OF THE CALENDAR YEAR IN WHICH IT IS FILED. I ALSO UNDERSTAND THAT I AM REQUIRED TO INFORM THE PUBLIC ENTITY PRIOR TO ENTERING INTO A CONTRACT IN EXCESS OF THE THRESHOLD AMOUNT PROVIDED IN SECTION 287.017, FLORIDA STATUTES, FOR CATEGORY TWO OF ANY CHANGE IN THE INFORMATION CONTAINED IN THIS FORM.

Frank P. Jappew (SIGNATURE)  
3/14/11  
(DATE)

STATE OF FL  
COUNTY OF Monroe

PERSONALLY APPEARED BEFORE ME, the undersigned authority Frank P. Toppino who, after first being sworn by me, Frank P. Toppino (name of individual) affixed his/her signature in the space provided above on this 14 day of March, 2011.

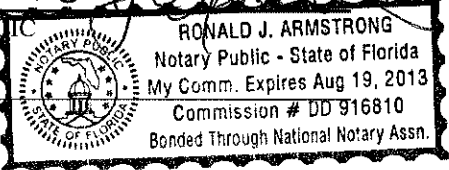
Ronald J. Armstrong  
NOTARY PUBLIC  
Printed Name 

My commission expires:

SUSPENSION AND DEBARMENT CERTIFICATION

CERTIFICATION REGARDING DEBARMENTS, SUSPENSION, INELIGIBILITY AND VOLUNTARY EXCLUSION-LOWER TIER FEDERALLY FUNDED TRANSACTIONS

1. The undersigned hereby certifies that neither it nor its principals is presently debarred, suspended, proposed for debarment, declared ineligible, or voluntarily excluded from participation in this transaction by any Federal department or agency.

2. The undersigned also certifies that it and its principals:

(a) Have not within a three-year period preceding this certification been convicted of or had a civil judgment rendered against them for commission of fraud or a criminal offense in connection with obtaining, attempting to obtain, or performing a public (Federal, State or local) transaction or contract under a public transaction; violation of Federal or State anti-trust statutes or commission of embezzlement, theft, forgery, bribery, falsification or destruction of records, making false statements, or receiving stolen property.

(b) Are not presently indicted for or otherwise criminally or civilly charged by a governmental entity (Federal, State or local) with commission of any of the offenses enumerated in paragraph 2.(a) of this Certification; and

(c) Have not within a three-year period preceding this certification had one or more public transactions (Federal, State or local) terminated for cause or default.

3. Where the undersigned is unable to certify to any of the statements in this certification, an explanation shall be attached to this certification.

Dated this 14 day of March, 2011.

By [Signature] Authorized Signature/Contractor

Frank P. Toppino President  
Typed Name/Title

CHARLEY TOPPINO & SONS, INC.

Contractor's Firm Name

P.O. Box 787 Key West, FL 33041  
Street Address

Building, Suite Number

Key West FL 33041  
City/State/Zip Code

Area Code/Telephone Number

305 296 5606

**DISCLOSURE OF LOBBYING ACTIVITIES**

Complete this form to disclose lobbying activities pursuant to 31 U.S.C. 1352  
(See reverse for public burden disclosure.)

<p><b>1. Type of Federal Action:</b></p> <p><input type="checkbox"/></p> <p>a. contract b. grant c. cooperative agreement d. loan e. loan guarantee f. loan insurance</p>	<p><b>2. Status of Federal Action:</b></p> <p><input type="checkbox"/></p> <p>a. bid/offer/application b. initial award c. post-award</p>	<p><b>3. Report Type:</b></p> <p><input type="checkbox"/></p> <p>a. initial filing b. material change</p> <p><b>For Material Change Only:</b></p> <p>year _____ quarter _____ date of last report _____</p>
<p><b>4. Name and Address of Reporting Entity:</b></p> <p><input type="checkbox"/> Prime <input type="checkbox"/> Subawardee Tier _____, if known:</p> <p><b>Congressional District, if known:</b></p>	<p><b>5. If Reporting Entity in No. 4 is Subawardee, Enter Name and Address of Prime:</b></p> <p style="text-align: center; font-size: 2em; margin: 20px 0;">MA</p> <p><b>Congressional District, if known:</b></p>	
<p><b>6. Federal Department/Agency:</b></p>	<p><b>7. Federal Program Name/Description:</b></p> <p>CFDA Number, if applicable: _____</p>	
<p><b>8. Federal Action Number, if known:</b></p>	<p><b>9. Award Amount, if known:</b></p> <p style="text-align: center;">\$</p>	
<p><b>10. a. Name and Address of Lobbying Entity</b> <i>(if individual, last name, first name, MI):</i></p>	<p><b>b. Individuals Performing Services</b> <i>(including address if different from No. 10a)</i> <i>(last name, first name, MI):</i></p>	
<p><i>(attach Continuation Sheet(s) SF-LLA, if necessary)</i></p>		
<p><b>11. Information requested through this form is</b></p>		
<p><b>Signature:</b></p>		

authorized by title 31 U.S.C. section 1352. This disclosure of lobbying activities is a material representation of fact upon which reliance was placed by the tier above when this transaction was made or entered into. This disclosure is required pursuant to 31 U.S.C. 1352. This information will be reported to Congress semi-annually and will be available for public inspection. Any person who fails to file the required disclosure shall be subject to a civil penalty of not less than \$10,000 and not more than \$100,000 for each such failure.

Print Name: Frank P. Toppino

Frank P. Toppino

Title: President

Telephone No.: 305 296 5606

Date: 3/14/11

Federal Use Only:

Authorized for Local Reproduction  
Standard Form - LLL (Rev 7 - 97)

Form DEP 55-221 (01/01)

## INSTRUCTIONS FOR COMPLETION OF SELF DISCLOSURE OF LOBBYING ACTIVITIES

This disclosure form shall be completed by the reporting entity, whether subawardee or prime Federal recipient, at the initiation or receipt of a covered Federal action, or a material change to a previous filing, pursuant to title 31 U.S.C. section 1352. The filing of a form is required for each payment or agreement to make payment to any lobbying entity for influencing or attempting to influence an officer or employee of any agency, a Member of Congress, an officer or employee of Congress, or an employee of a Member of Congress in connection with a covered Federal action. Complete all items that apply for both the initial filing and material change report. Refer to the implementing guidance published by the Office of Management and Budget for additional information.

1. Identify the type of covered Federal action for which lobbying activity is and/or has been secured to influence the outcome of a covered Federal action.
2. Identify the status of the covered Federal action.
3. Identify the appropriate classification of this report. If this is a follow up report caused by a material change to the information previously reported, enter the year and quarter in which the change occurred. Enter the date of the last previously submitted report by the reporting entity for this covered Federal action.
4. Enter the full name, address, city, state and zip code of the reporting entity. Include Congressional District, if known. Check the appropriate classification of the reporting entity that designates if it is or expects to be, a prime or subaward recipient. Identify the tier of the subawardee, e.g., the first subawardee of the prime is the 1st tier. Subawards include but are not limited to subcontracts, subgrants and contract awards under grants.
5. If the organization filing the report in item 4 checks "Subawardee", then enter the full name, address, city, state and zip code of the prime Federal recipient. Include Congressional District, if known.
6. Enter the name of the Federal agency making the award or loan commitment. Include at least one organizational level below agency name, if known. For example, Department of Transportation, United States Coast Guard.
7. Enter the Federal program name or description for the covered Federal action (item 1). If known, enter the full Catalog of Federal Domestic Assistance (CFDA) number for grants, cooperative agreements, loans, and loan commitments.
8. Enter the most appropriate Federal identifying number available for the Federal action identified in item 1 (e.g., Request for Proposal (RFP) number; Invitation for Bid (IFB) number; grant announcement number; the contract, grant, or loan award number; the application/proposal control number assigned by the Federal agency). Include prefixes, e.g., "RFP-DE-90-001."
9. For a covered Federal action where there has been an award or loan commitment by the Federal agency, enter the Federal amount of the award/loan commitment for the prime entity identified in item 4 or 5.
10. (a) Enter the full name, address, city, state and zip code of the lobbying entity engaged by the reporting entity identified in item 4 to influence the covered Federal action.  
  
(b) Enter the full names of the individual(s) performing services, and include full address if different from 10 (a). Enter Last Name, First Name, and Middle Initial (MI).
11. The certifying official shall sign and date the form, print his/her name, title and telephone number.

According to the Paperwork Reduction Act, as amended, no persons are required to respond to a collection of information unless it displays a valid OMB Control Number. The valid OMB control number for this information collection is OMB No. 0348-0046. Public reporting burden for this collection of information is estimated to average 30 minutes per response, including time for reviewing instructions, searching existing data sources, gathering and maintaining the data needed, and completing and reviewing the collection of information. Send comments regarding the burden estimate or any other aspect of this collection of information, including suggestions for reducing this burden, to the Office of Management and Budget, Paperwork Reduction Project (0348-0046), Washington, D.C. 20503.

Form DEP 55-221 (01/01)

**NON-COLLUSION DECLARATION AND  
COMPLIANCE WITH 49 CFR §29.**  
STATE OF FLORIDA DEPARTMENT OF TRANSPORTATION

ITEM/SEGMENT NO.: \_\_\_\_\_  
F.A.P. NO.: 421 379-1  
PARCEL NO.: \_\_\_\_\_  
COUNTY OF: Monroe  
BID LETTING OF: March 24, 2011

I, Frank P. Toppino, hereby  
declare that I am President (NAME) of CHARLEY TOPPINO & SONS, INC.  
Of Key West, FL (TITLE) (CITY AND STATE) (FIRM)

and that I am the person responsible within my firm for the final decision as to the price(s) and amount of this Bid on this State Project.

I further declare that:

1. The prices(s) and amount of this bid have been arrived at independently, without consultation, communication or agreement, for the purpose of restricting competition with any other contractor, bidder or potential bidder.

2. Neither the price(s) nor the amount of this bid have been disclosed to any other firm or person who is a bidder or potential bidder on this project, and will not be so disclosed prior to the bid opening.

3. No attempt has been made or will be made to solicit, cause or induce any other firm or person to refrain from bidding on this project, or to submit a bid higher than the bid of this firm, or any intentionally high or non-competitive bid or other form of complementary bid.

4. The bid of my firm is made in good faith and not pursuant to any agreement or discussion with, or inducement from, any firm or person to submit a complementary bid.

5. My firm has not offered or entered into a subcontract or agreement regarding the purchase of materials or services from any firm or person, or offered, promised or paid cash or anything of value to any firm or person, whether in connection with this or any other project, in consideration for an agreement or promise by any firm or person to refrain from bidding or to submit a complementary bid on this project.

6. My firm has not accepted or been promised any subcontract or agreement regarding the sale of materials or services to any firm or person, and has not been promised or paid cash or anything of value by any firm or person, whether in connection with this or any other project, in consideration for my firm's submitting a complementary bid, or agreeing to do so, on this project.

7. I have made a diligent inquiry of all members, officers, employees, and agents of my firm with responsibilities relating to the preparation, approval or submission of my firm's bid on this project and have been advised by each of them that he or she has not participated in any communication, consultation, discussion, agreement, collusion, act or other conduct inconsistent with any of the statements and representations made in this Declaration.

8. As required by Section 337.165, Florida Statutes, the firm has fully informed the Department of Transportation in writing of all convictions of the firm, its affiliates (as defined in Section 337.165(l)(a), Florida Statutes), and all directors, officers, and employees of the firm and its affiliates for violation of state or federal antitrust laws with respect to a public contract or for violation of any state or federal law involving fraud, bribery, collusion, conspiracy or material misrepresentation with respect to a public contract. This includes disclosure of the names of current employees of the firm or affiliates who were convicted of contract crimes while in the employ of another company.

9. I certify that, except as noted below, neither my firm nor any person associated therewith in the capacity of owner, partner, director, officer, principal, investigator, project director, manager, auditor, and/or position involving the administration of Federal funds:

(a) is presently debarred, suspended, proposed for debarment, declared ineligible, or voluntarily excluded from covered transactions, as defined in 49 CFR §29.110(a), by any Federal department or agency;

(b) has within a three-year period preceding this certification been convicted of or had a civil judgment rendered against him or her for: commission of fraud or a criminal offense in connection with obtaining, attempting to obtain, or performing a Federal, State or local government transaction or public contract; violation of Federal or State antitrust statutes; or commission of embezzlement, theft, forgery, bribery, falsification or destruction of records, making false statements or receiving stolen property;

(c) is presently indicted for or otherwise criminally or civilly charged by a Federal, State or local governmental entity with commission of any of the offenses enumerated in paragraph 9(b) of this certification; and

(d) has within a three-year period preceding this certification had one or more Federal, State or local government public transactions terminated for cause or default..

10. I(We), certify that I(We), shall not knowingly enter into any transaction with any subcontractor, material supplier, or vendor who is debarred, suspended, declared ineligible, or voluntarily excluded from participation in this contract by any Federal Agency unless authorized by the Department.

Where I am unable to declare or certify as to any of the statements contained in the above stated paragraphs numbered (1) through (10), I have provided an explanation in the "Exceptions" portion below or by attached separate sheet.

EXCEPTIONS:

(Any exception listed above will not necessarily result in denial of award, but will be considered in determining bidder responsibility. For any exception noted, indicate to whom it applies, initiating agency and dates of agency action.

Providing false information may result in criminal prosecution and/or administrative sanctions.)

I declare under penalty of perjury that the foregoing is true and correct.

CONTRACTOR: (Seal)

BY: Frank P. Toppino President WITNESS: Ronald J Armstrong  
NAME AND TITLE PRINTED

BY: Frank P. Toppino WITNESS: Ronald J Armstrong  
SIGNATURE

Executed on this 14 day of March, 2011

**FAILURE TO FULLY COMPLETE AND EXECUTE THIS DOCUMENT  
MAY RESULT IN THE BID BEING DECLARED NONRESPONSIVE**

**CITY OF KEY WEST INDEMNIFICATION FORM**

The Contractor shall indemnify and hold harmless the City of Key West, its officers, and employees, from liabilities, damages, losses and costs, including, but not limited to reasonable attorney's fees, to the extent caused by the negligence, recklessness or intentional wrongful misconduct of Contractor and persons employed or utilized by Contractor in the performance of this agreement. Except as specifically provided herein, this agreement does not require Contractor to indemnify the City of Key West, its employees, officers, directors, or agents from any liability, damage, loss, claim, action or proceeding.

These indemnifications shall survive the term of this agreement. In the event that any action or proceeding is brought against the City of Key West by reason of such claim or demand, Contractor shall, upon written notice from the City of Key West, resist and defend such action or proceeding by counsel satisfactory to the City of Key West.

The indemnification provided above shall obligate Contractor to defend at its own expense to and through appellate, supplemental or bankruptcy proceeding, or to provide for such defense, at the City of Key West's option, any and all claims of liability and all suits and actions of every name and description covered above which may be brought against the City of Key West whether performed by Contractor, or persons employed or utilized by Contractor.

The Contractor's obligation under this provision shall not be limited in any way by the agreed upon Contract Price as shown in this agreement, or the Contractor's limit of or lack of sufficient insurance protection.

CONTRACTOR: **CHARLEY TOPPINO & SONS, INC.**  
*Frank P. Toppino* SEAL:  
P.O. Box 787 Key West, FL 33041  
Address  
Frank P. Toppino  
Signature  
Frank P. Toppino  
Print Name  
President  
Title  
DATE: 3/14/11



## BIDDER'S CHECKLIST

(Note: The purpose of this checklist is to serve as a reminder of major items to be addressed in submitting a bid and is not intended to be all inclusive. It does not alleviate the Bidder from the responsibility of becoming familiar with all aspects of the Contract Documents and Proper completion and submission of his bid.)

1. All Contract Documents thoroughly read and understood
2. All blank spaces in Proposal filled in, using black ink.
3. Total and unit Prices added correctly.
4. Addenda acknowledged.
5. Subcontractors are named as indicated in the Proposal.
6. Experience record included.
7. Proposal signed by authorized officer.
8. Bid Bond completed and executed, including power-of-attorney dated the same date as Bid Bond.
9. Bidder familiar with federal, state, and local laws, ordinances, rules and regulations affecting performance of the work.
10. Bidder shall demonstrate possession of required licenses and certificates to bid the job.
11. Proposal submitted intact with the volume entitled "Proposal" and Contract Forms, submit 1 original & 2 copies and 2 CD-Roms or flash drives each with one PDF file of the full Proposal.
12. Bid Documents submitted in sealed envelope and addressed and labeled in conformance with the instructions in the Invitation to Bid.
13. Bidder submitted FDOT Pre-certification paperwork
14. Bidder signed and submitted the suspension and debarment certification
15. Bidder signed and submitted Non-Collusion Declaration and Compliance with 49 CFR §29 form
16. Bidder signed and submitted the Prohibited Interests Form
17. Remainder of required forms.

---

---

**STATEMENT OF NO PROPOSAL**

Note: If you do not intend to submit a Proposal, please return this form ONLY.

TO: "College Road Enhancements, Overseas Highway to Kokenzie Road" GN 0711  
Office of the City Clerk  
City of Key West P.O. Box 1409  
Key West, FL. 33041-1409

We, the undersigned, have declined to submit a Proposal on the above-noted Request for Proposal for the following reasons:

- Insufficient time to respond to the Request for Proposal
- Do not offer this Product
- Our schedule will not permit us to perform
- Unable to meet specifications
- Specifications unclear (Please explain below)
- Remove us from the City of Key West's, "Bidder's Mailing List"
- Other (Please specify below)

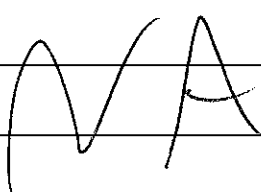
REMARKS: \_\_\_\_\_  
\_\_\_\_\_   
\_\_\_\_\_

We understand that if a "no Proposal" statement is not returned, our name may be removed from the bidder's list of the City of Key West.

COMPANY NAME: \_\_\_\_\_

SIGNATURE: \_\_\_\_\_

DATE: \_\_\_\_\_ TELEPHONE: \_\_\_\_\_

AC# 4482291

STATE OF FLORIDA

DEPARTMENT OF BUSINESS AND PROFESSIONAL REGULATION  
CONSTRUCTION INDUSTRY LICENSING BOARD

SEQ# L09072300719

DATE	BATCH NUMBER	LICENSE NBR
07/23/2009	090047121	QB64716

The BUSINESS ORGANIZATION  
Named below IS QUALIFIED  
Under the provisions of Chapter 489 FS  
Expiration date: AUG 31, 2011  
(THIS IS NOT A LICENSE TO PERFORM WORK. THIS ALLOWS THE  
COMPANY TO DO BUSINESS ONLY IF IT HAS A QUALIFIER.)

CHARLEY TOPPINO & SONS INC  
PO BOX 787  
KEY WEST FL 33040

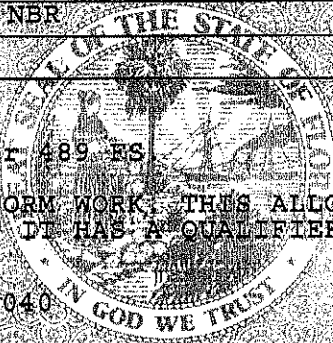

CHARLIE CRIST  
GOVERNOR

DISPLAY AS REQUIRED BY LAW

CHARLES W. DRAGO  
SECRETARY

AC# 4482179

STATE OF FLORIDA

DEPARTMENT OF BUSINESS AND PROFESSIONAL REGULATION  
CONSTRUCTION INDUSTRY LICENSING BOARD

SEQ# L09072300607

DATE	BATCH NUMBER	LICENSE NBR
07/23/2009	090047095	RG0045369

The GENERAL CONTRACTOR  
Named below HAS REGISTERED  
Under the provisions of Chapter 489 FS  
Expiration date: AUG 31, 2011  
(INDIVIDUAL MUST MEET ALL LOCAL LICENSING  
REQUIREMENTS PRIOR TO CONTRACTING IN ANY AREA)

TOPPINO, FRANK P  
CHARLEY TOPPINO & SONS INC  
POST OFFICE BOX 787  
KEY WEST FL 33041-0787

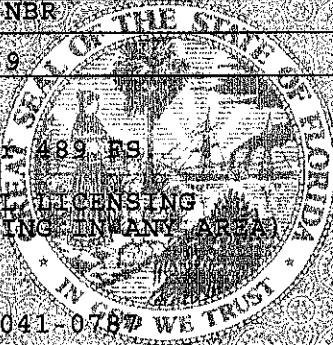

CHARLIE CRIST  
GOVERNOR

DISPLAY AS REQUIRED BY LAW

CHARLES W. DRAGO  
SECRETARY

CITY OF KEY WEST  
CERTIFICATE OF COMPETENCY

# 121 THIS IS TO CERTIFY THAT

Frank Toppino  
is duly registered as a  
General Contractor

in conformity with the regulations of the City of Key West

Date Issued: 10/01/09 Exp Date: 09/30/11

By: John P. Wood  
CHIEF BUILDING OFFICIAL

CITY OF KEY WEST  
CERTIFICATE OF COMPETENCY

# 3064 THIS IS TO CERTIFY THAT

Frank Toppino  
is duly registered as a  
Engineering Contractor

in conformity with the regulations of the City of Key West

Date Issued: 10/01/09 Exp Date: 09/30/11

By: John P. Wood  
CHIEF BUILDING OFFICIAL

# CITY OF KEY WEST, FLORIDA

## Business Tax Receipt

This Document is a business tax receipt  
Holder must meet all City zoning and use provisions.  
P.O. Box 1409, Key West, Florida 33040 (305) 809-3955

Business Name CHARLEY TOPPINO & SONS (EDWAR) CtlNbr:0005358  
Location Addr MM 8 1/2 ROCKLAND KEY  
Lic NBR/Class 11-00017557 CONTRACTOR REG ENGINEERING I  
Issue Date: September 10, 2010 Expiration Date: September 30, 2011  
License Fee \$309.75  
Add. Charges \$0.00  
Penalty \$0.00  
Total \$309.75

Comments:

This document must be prominently displayed.

CHARLEY TOPPINO & SONS, INC.

CHARLEY TOPPINO & SONS (EDWAR)  
EDWARD TOPPINO  
P.O. BOX 787  
KEY WEST FL 33041

Original Licensee Type: CC Drawn: 1  
Date: 9/10/10 51 Receipt nr: 100775  
DR 17557  
CASH 115 00000000 1 \$309.75  
CASH 51532 \$309.75  
Total Payment \$309.75  
Trans Date: 9/12/10 Time: 13:56:24

# CITY OF KEY WEST, FLORIDA

## Business Tax Receipt

This Document is a business tax receipt  
 Holder must meet all City zoning and use provisions.  
 P.O. Box 1409, Key West, Florida 33040 (305) 809-3955

Business Name	CHARLEY TOPPINO & S (FRANK ENG	CtlNbr:0010428
Location Addr	2011 FLAGLER AVE	
Lic NBR/Class	11-00023995 CONTRACTOR - REG ENGINEERING I	
Issue Date:	September 15, 2010	Expiration Date: September 30, 2011
License Fee	\$309.75	
Add. Charges	\$0.00	
Penalty	\$0.00	
Total	\$309.75	
Comments:		

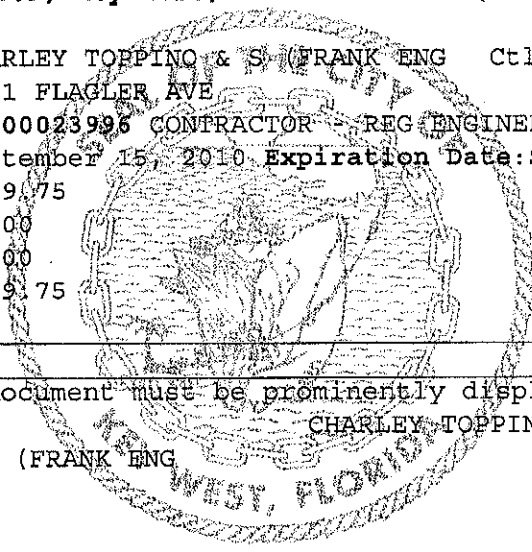

This document must be prominently displayed.

CHARLEY TOPPINO & SONS, INC.

CHARLEY TOPPINO & S (FRANK ENG  
 FRANK TOPPINO  
 P.O. BOX 787  
 KEY WEST FL 33041

Date: 9/16/10 55  
 2096  
 LEO GONZALEZ  
 TRANS NUMBER: 51556  
 CK CHECK  
 TYPE: DC  
 RECEIPT NO: 11294  
 4089.75  
 3399.75  
 4089.75  
 12:44:21

# CITY OF KEY WEST, FLORIDA

## Business Tax Receipt

This Document is a business tax receipt  
Holder must meet all City zoning and use provisions.  
P.O. Box 1409, Key West, Florida 33040 (305) 809-3955

Business Name CHARLEY TOPPINO & S (FRANK RG) CtlNbr:0005344  
Location Addr 2011 FLAGLER AVE  
Lic NBR/Class 11-00023997 CONTRACTOR - REG GENERAL  
Issue Date: September 15, 2010 Expiration Date: September 30, 2011  
License Fee \$309.75  
Add. Charges \$0.00  
Penalty \$0.00  
Total \$309.75  
Comments:

This document must be prominently displayed.

FRANK P. TOPPINO

CHARLEY TOPPINO & S (FRANK RG)  
POB 787

KEY WEST FL 33041

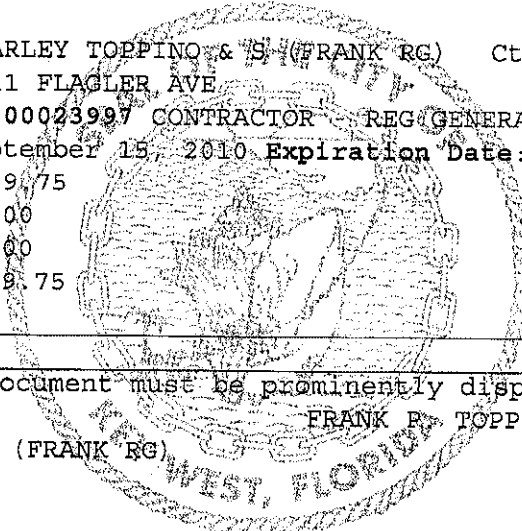

Printed: 9/15/10 11:24:19  
Date: 9/15/10 11:24:19  
Lic Nbr: 11-00023997  
Lic Class: CONTRACTOR - REG GENERAL  
Lic Fee: \$309.75  
Lic Status: ACTIVE  
Lic Expiration: 9/30/11  
Lic Issued: 9/15/10  
Lic Renewal: 9/15/11  
Lic Renewal Fee: \$309.75  
Lic Renewal Date: 9/15/11  
Lic Renewal Status: PENDING  
Lic Renewal Reason: LIC EXPIRED  
Lic Renewal Date: 9/15/11  
Lic Renewal Status: PENDING  
Lic Renewal Reason: LIC EXPIRED

**2010 / 2011  
MONROE COUNTY BUSINESS TAX RECEIPT  
EXPIRES SEPTEMBER 30, 2011**

RECEIPT# 30140-89799

Business Name: CHARLEY TOPPINO & SONS, INC.

Owner Name: FRANK TOPPINO  
Mailing Address: BOX 787  
KEY WEST, FL 33040

Business Location: MM 8-9 US HWY 1

Business Phone:  
Business Type: CONTRACTORS (GEN CONT/ENGINEERING  
CONT)

Rooms      Seats      Employees      Machines      Stalls

	Number of Machines	For Vending Business Only	Vending Type:				
Tax Amount	Transfer Fee	Sub Total	Penalty	Prior Years	Collection Cost	Total Paid	
250.00	0.00	250.00	0.00	0.00	0.00	250.00	

Paid 122-09-00006408 09/08/2010 250.00

**THIS RECEIPT MUST BE POSTED CONSPICUOUSLY IN YOUR PLACE OF BUSINESS**

THIS BECOMES A TAX RECEIPT  
WHEN VALIDATED

**Danise D. Henriquez, CFC, Tax Collector**  
PO Box 1129, Key West, FL 33041

THIS IS ONLY A TAX.  
YOU MUST MEET ALL  
COUNTY AND/OR  
MUNICIPALITY PLANNING  
AND ZONING REQUIREMENTS.



**2010 / 2011  
MONROE COUNTY BUSINESS TAX RECEIPT  
EXPIRES SEPTEMBER 30, 2011**

RECEIPT# 39140-67814

Business Name: MONROE CONCRETE PRODUCTS, INC.

Owner Name: FRANK AND GEORGE TOPPING  
Mailing Address: PO DRAWER 1149  
KEY WEST, FL 33041

Business Location: MM 9 ROCKLAND KEY

Business Phone: 305-296-9164  
Business Type: MANUFACTURING (MANUFACTURING CONCRETE)

**Rooms      Seats      Employees      Machines      Stalls**

Tax Amount	Transfer Fee	Sub Total	Penalty	Prior Years	Collection Cost	Total Paid
30.00	0.00	30.00	0.00	0.00	0.00	30.00

Paid 122-09-00006413      09/08/2010      30.00

**THIS RECEIPT MUST BE POSTED CONSPICUOUSLY IN YOUR PLACE OF BUSINESS**

THIS BECOMES A TAX RECEIPT  
WHEN VALIDATED

**Danise D. Henriquez, CFC, Tax Collector**  
PO Box 1129, Key West, FL 33041

THIS IS ONLY A TAX.  
YOU MUST MEET ALL  
COUNTY AND/OR  
MUNICIPALITY PLANNING  
AND ZONING REQUIREMENTS.

**2010 / 2011  
MONROE COUNTY BUSINESS TAX RECEIPT  
EXPIRES SEPTEMBER 30, 2011**

RECEIPT# 30140-9142

Business Name: TOPPINO FRANK P

Owner Name: FRANK P TOPPINO

Mailing Address: PO BOX 787  
KEY WEST, FL 33040

Business Location: US HWY 1

Business Phone: 305-296-5606

Business Type: CONTRACTORS (GENERAL/ENGINEERING CONTRACTOR)

Rooms      Seats      Employees      Machines      Stalls

RG0045369 GC152A ENG I I32A

		For Vending Business Only			Vending Type:			
Tax Amount	Transfer Fee	Subtotal	Penalty	Prior Year	Collection Cost	Total Paid		
125.00	0.00	125.00	0.00	0.00	0.00	125.00		

Paid 122-09-00006407 09/08/2010 125.00

**THIS RECEIPT MUST BE POSTED CONSPICUOUSLY IN YOUR PLACE OF BUSINESS**

THIS BECOMES A TAX RECEIPT  
WHEN VALIDATED

**Danise D. Henriquez, CFC, Tax Collector**  
PO Box 1129, Key West, FL 33041

THIS IS ONLY A TAX.  
YOU MUST MEET ALL  
COUNTY AND/OR  
MUNICIPALITY PLANNING  
AND ZONING REQUIREMENTS.

**2010 / 2011  
MONROE COUNTY BUSINESS TAX RECEIPT  
EXPIRES SEPTEMBER 30, 2011**

RECEIPT# 46110-89800

Business Name: CHARLEY TOPPINO & SONS, INC.

Owner Name: EDWARD TOPPINO, SR.  
Mailing Address: P O BOX 787  
KEY WEST, FL 33041

Business Location: 8.5 ROCKLAND KEY

Business Phone: \_\_\_\_\_  
Business Type: PROFESSIONALS (ENG CLASS I CC 749 A)

Rooms                      Seats                      Employees                      Machines                      Stalls

Tax Amount	Transfer Fee	Supplemental	Penalty	Prior Years	Collection Cost	Total Paid
30.00	0.00	0.00	0.00	0.00	0.00	30.00

Paid 122-09-00006409 09/08/2010 30.00

**THIS RECEIPT MUST BE POSTED CONSPICUOUSLY IN YOUR PLACE OF BUSINESS**

THIS BECOMES A TAX RECEIPT  
WHEN VALIDATED

**Danise D. Henriquez, CFC, Tax Collector**  
PO Box 1129, Key West, FL 33041

THIS IS ONLY A TAX.  
YOU MUST MEET ALL  
COUNTY AND/OR  
MUNICIPALITY PLANNING  
AND ZONING REQUIREMENTS.

**2010 / 2011  
MONROE COUNTY BUSINESS TAX RECEIPT  
EXPIRES SEPTEMBER 30, 2011**

RECEIPT# 30140-7153

Business Name: TOPPINO CONSTRUCTION CO, INC

Owner Name: EDWARD TOPPINO SR  
Mailing Address: PO BOX 787  
KEY WEST, FL 33041

Business Location: ROCKLAND KEY

Business Phone: 305-296-5606  
Business Type: CONTRACTORS (ENGINEERING CONTRACTOR (B1A))

Rooms      Seats      Employees      Machines      Stalls

10

EC 131A/10/05

Number of Machines		For Vending Business Only		Vending Type:			
Tax Amount	Transfer Fee	Sub-Total	Penalty	Prior Years	Collection Cost	Total Paid	
25.00	0.00	25.00	0.00	0.00	0.00	0.00	25.00

Paid 122-09-00006410 09/08/2010 25.00

**THIS RECEIPT MUST BE POSTED CONSPICUOUSLY IN YOUR PLACE OF BUSINESS**

THIS BECOMES A TAX RECEIPT  
WHEN VALIDATED

**Danise D. Henriquez, CFC, Tax Collector  
PO Box 1129, Key West, FL 33041**

THIS IS ONLY A TAX.  
YOU MUST MEET ALL  
COUNTY AND/OR  
MUNICIPALITY PLANNING  
AND ZONING REQUIREMENTS.

**2010 / 2011  
MONROE COUNTY BUSINESS TAX RECEIPT  
EXPIRES SEPTEMBER 30, 2011**

RECEIPT# 53110-25514

Business Name: ROCKLAND RECYCLING CENTER ENERGY  
COMMONS INC DBA

Owner Name: FRANK & EDWARD & GEORGE TOPPING  
Mailing Address: P O BOX 1149  
KEY WEST, FL 33041

Business Location: MM 8.5 US HWY 1

Business Phone: 305-296-5606

Business Type: WHOLESALE SALES (RECYCLING CONST  
DEBRIS)

**Rooms      Seats      Employees      Machines      Stalls**

		For Vending Business Only							
		Number of Machines				Vending Type:			
Tax Amount	Transfer Fee	Sub Total	Penalty	Prior Year	Collection Cost	Total Paid			
30.00	0.00	30.00	0.00	0.00	0.00	0.00	30.00		

Paid 122-09-00006411      09/08/2010      30.00

**THIS RECEIPT MUST BE POSTED CONSPICUOUSLY IN YOUR PLACE OF BUSINESS**

THIS BECOMES A TAX RECEIPT  
WHEN VALIDATED

**Danise D. Henriquez, CFC, Tax Collector  
PO Box 1129, Key West, FL 33041**

THIS IS ONLY A TAX.  
YOU MUST MEET ALL  
COUNTY AND/OR  
MUNICIPALITY PLANNING  
AND ZONING REQUIREMENTS.



## Florida Department of Transportation

CHARLIE CRIST  
GOVERNOR

605 Suwannee Street  
Tallahassee, FL 32399-0450

STEPHANIE C. KOPELOUSOS  
SECRETARY

May 17, 2010

CHARLEY TOPPINO & SONS, INC.  
PO BOX 787  
KEY WEST FLORIDA 33041

RE: CERTIFICATE OF QUALIFICATION

Dear Sir/Madam:

The Department of Transportation has qualified your company for the amount and the type of work indicated below. Unless your company is notified otherwise, this rating will expire 6/30/2011. However, the new application is due 4/30/2011.

In accordance with S.337.14 (1) F.S. your next application must be filed within (4) months of the ending date of the applicant's audited annual financial statements and, if applicable, the audited interim financial statements. Section 337.14 (4) F.S. provides that your certificate will be valid for 18 months after your financial statement date. This gives a two month period to allow you to bid on jobs as we process your new application for qualification. To remain qualified with the Department, a new application must be submitted subsequent to any significant change in the financial position or the structure of your firm as described in Section 14-22.005(3), Florida Administrative Code.

MAXIMUM CAPACITY RATING: \$392,950,000.00

**FDOT APPROVED WORK CLASSES:**

DEBRIS REMOVAL (EMERGENCY), DRAINAGE, FLEXIBLE PAVING, GRADING, GRASSING, SEEDING AND SODDING, INTERMEDIATE BRIDGES, MINOR BRIDGES, ROADWAY SIGNING

**FDOT APPROVED SPECIALITY CLASSES OF WORK:**

UNDERGROUND UTILITIES, SIDEWALKS CONCRETE CURB.

Please be advised the Department of Transportation has considered your company's qualification in all work classes requested. We have evaluated your company's organization, management, work experience, work performance and adequacy of equipment as directed by section 14-22.003, Florida Administrative Code. Based on this evaluation, the Department is not able, at this time, to prequalify your company for the work classes: R&R INTERMEDIATE BRIDGES, R&R MINOR BRIDGES.

CHARLEY TOPPINO & SONS, INC.

May 17, 2010

Page two

You may apply, in writing, for a Revised Certificate of Qualification at any time prior to the expiration date of this certificate according to Section 14-22.0041(3), Florida Administrative Code. Please be advised if certification in additional classes of work is desired, documentation is needed to show that your company has done such work with your own forces and equipment or that experience was gained with another contractor and that you have the necessary equipment for each additional class of work requested.

Sincerely,

A handwritten signature in cursive script that reads "Juanita Moore".

Juanita Moore, Manager  
Contracts Administration Office

JM:cj



## THE CITY OF KEY WEST

Post Office Box 1409 Key West, FL 33041-1409 (305) 809-3867

### ADDENDUM # 1 COLLEGE ROAD ENHANCEMENTS – GN 0711

March 28, 2011

To All Bidders,

The following changes are hereby made a part of Project number GN 0711, College Road Enhancements, as fully as completely as if the same were fully set forth therein:

#### Question/Response:

1. **Question:** Will detectable warnings also be included in the area where the 4-foot wide section leading from the bus pad meets the edge of the street?

**Response:** Yes, it will. Detectable warnings will have an area of 2-ft. deep x 4-ft. wide and will be placed approximately 6 to 8-inches back from the edge of pavement.

2. **Question:** Bridging over structure. Will any wire mesh or equivalent reinforcement be required?

**Response:** Yes, there will. Longitudinally, #6 bars should be spaced every 6". They should extend 1-foot into the thickened portion before the bridged section. Transversely, #6 bars should be spaced every 12". Please refer to attached sketch below.

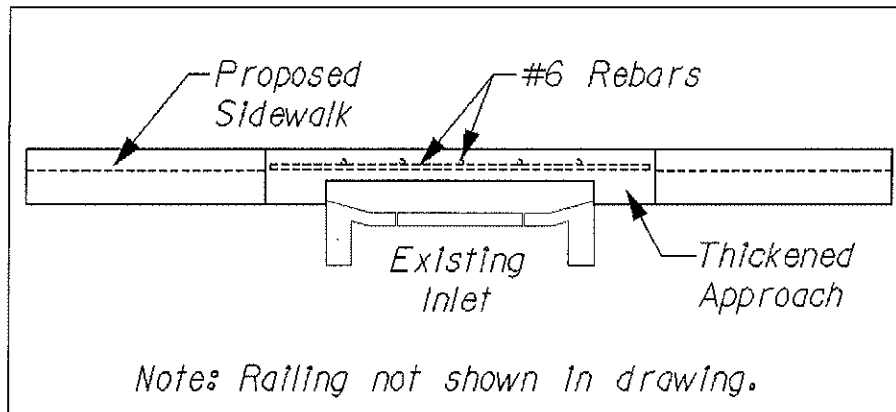

3. **Question:** Will a curb be required on the inside for wheelchair occupants?

**Response:** No. Please refer to the General Notes, item #1.



**General Notes:**

1. Sheet C-12: Construction Details show the use of an aluminum pipe guiderail. This will be changed to an aluminum pedestrian/bicycle picket railing as per 2010 FDOT Design Standards 860, Sheet no. 2 of 5. Height shall be 3'-6" (42"). Please refer to drawing below and the .

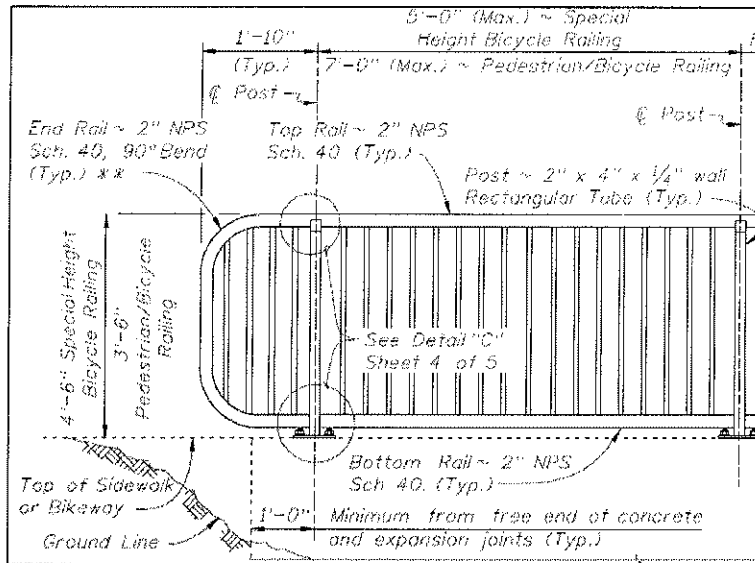

2. An additional Add/Alternate item will be gravel (1/2" to 3/4") with a quantity of **65** Tons. Please refer to following sheet which will replace page 21 of the Bid Documents package. In addition, please refer to sheets C-07 and C-08 at end of addendum denoting where swales will be incorporated.

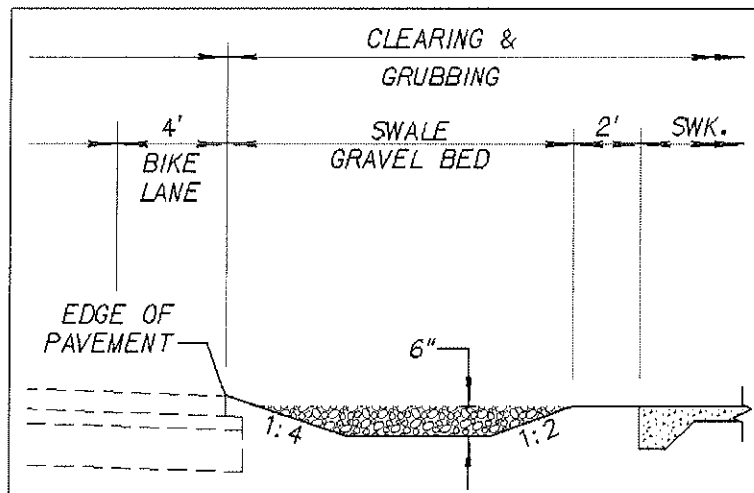

3. Please note that the number of shelters has been reduced from six (6) to two (2). These shelters are located at Sta. 18+71.60 and Sta. 24+95.80.
4. Please note that the 26.65-ft. long 5-ft. wide path leading to the bus stop at station 10+65.10 on sheet C-05 is no longer required. This item may be removed from the total quantity of concrete required.

*Key to the Caribbean – average yearly temperature 77 ° Fahrenheit.*

**ADD/ALTS 1-4**

Add Alternates are not a part of the base bid and shall only be added to the contract at the owners discretion.

<u>Item</u>	<u>Quant.</u>	<u>Unit</u>	<u>UP (Fig)</u>	<u>UP (Words)</u>	<u>Extended Total Amount</u>
1). Seepage Trench					
	100	LF	\$ _____	_____	\$ _____
2). Striping (White retro-reflective 6", as required)					
	0.6	NM	\$ _____	_____	\$ _____
3). Bus Shelters					
	2	EA	\$ _____	_____	\$ _____
4). Gravel Stone, 1/2 inch to 3/4 inch diameter (includes cost of material and labor to excavate 6" deep shoulder, grade bottom of shoulder, and backfill. Gravel will be for use in specified areas between edge of pavement and front of sidewalk as directed by the engineer).					
	65	TONS	\$ _____	_____	\$ _____

**TOTAL OF ADD/ALT UNIT PRICE ITEMS LISTED ABOVE**

\$ \_\_\_\_\_ Dollars and \_\_\_\_\_ Cents  
(Amount Written in Words has Precedence)

All Bidders shall acknowledge receipt and acceptance of this Addendum NO. 1 by acknowledging Addendum in their proposal or by submitting the addendum with the bid package. Bids submitted without acknowledgement or without this Addendum may be considered non-responsive.

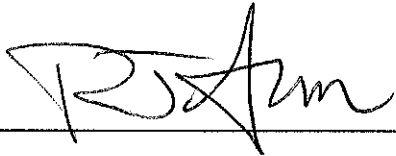
A handwritten signature in black ink, appearing to be 'R. J. Am', written over a horizontal line.

Signature

**CHARLEY TOPPINO & SONS, INC.**

Name of Business



THE CITY OF KEY WEST

Post Office Box 1409 Key West, FL 33041-1409 (305) 809-3867

**ADDENDUM # 1  
COLLEGE ROAD ENHANCEMENTS – GN 0711**

March 29, 2011

To All Bidders,

The following changes are hereby made a part of Project number GN 0711, College Road Enhancements, as fully as completely as if the same were fully set forth therein:

The bid opening date has been extended to WEDNESDAY APRIL 13, 2011 at 3:30 p.m.

**Question/Response:**

1. **Question:** Will detectable warnings also be included in the area where the 4-foot wide section leading from the bus pad meets the edge of the street?

**Response:** Yes, it will. Detectable warnings will have an area of 2-ft. deep x 4-ft. wide and will be placed approximately 6 to 8-inches back from the edge of pavement.

2. **Question:** Bridging over structure. Will any wire mesh or equivalent reinforcement be required?

**Response:** Yes, there will. Longitudinally, #6 bars should be spaced every 6". They should extend 1-foot into the thickened portion before the bridged section. Transversely, #6 bars should be spaced every 12". Please refer to attached sketch below.

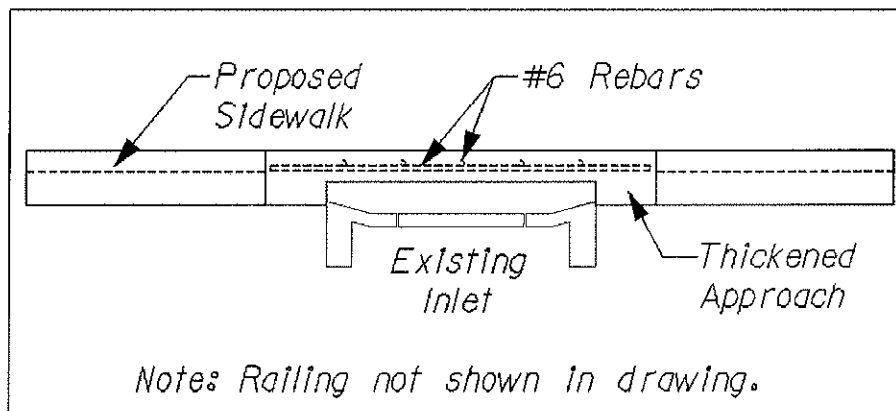

3. **Question:** Will a curb be required on the inside for wheelchair occupants?

**Response:** No. Please refer to the General Notes, item #1.

**General Notes:**

1. Sheet C-12: Construction Details show the use of an aluminum pipe guiderail. This will be changed to an aluminum pedestrian/bicycle picket railing as per 2010 FDOT Design Standards 860, Sheet no. 2 of 5. Height shall be 3'-6" (42"). Please refer to drawing below and the .

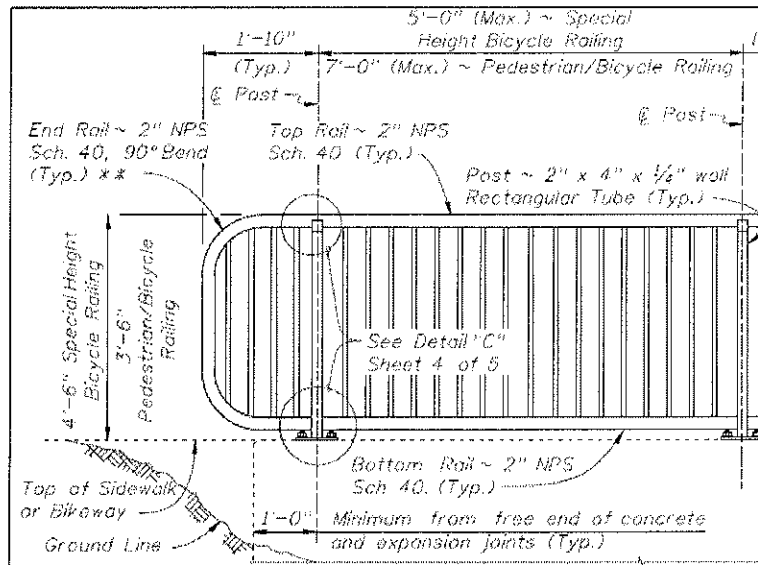

2. An additional Add/Alternate item will be gravel (1/2" to 3/4") with a quantity of **65** Tons. Please refer to following sheet which will replace page 21 of the Bid Documents package. In addition, please refer to sheets C-07 and C-08 at end of addendum denoting where swales will be incorporated.

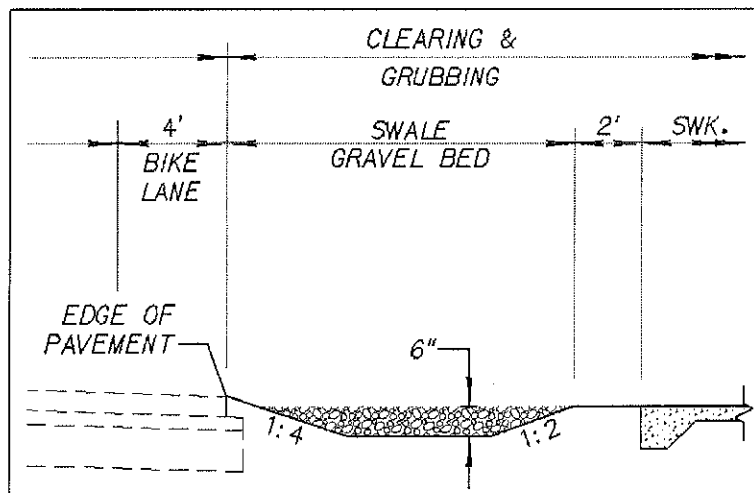

*Key to the Caribbean — average yearly temperature 77 ° Fahrenheit.*

3. Please note that the number of shelters has been reduced from six (6) to two (2). These shelters are located at Sta. 18+71.60 and Sta. 24+95.80.
4. Please note that the 26.65-ft. long 5-ft. wide path leading to the bus stop at station 10+65.10 on sheet C-05 is no longer required. This item may be removed from the total quantity of concrete required.

**ADD/ALTS 1-4**

**Add Alternates are not a part of the base bid and shall only be added to the contract at the owners discretion.**

<u>Item</u>	<u>Quant.</u>	<u>Unit</u>	<u>UP (Fig)</u>	<u>UP (Words)</u>	<u>Extended Total Amount</u>
1). Seepage Trench					
	100	LF	\$ _____	_____	\$ _____
2). Striping (White retro-reflective 6", as required)					
	0.6	NM	\$ _____	_____	\$ _____
3). Bus Shelters					
	2	EA	\$ _____	_____	\$ _____
4). Gravel Stone, 1/2 inch to 3/4 inch diameter (includes cost of material and labor to excavate 6" deep shoulder, grade bottom of shoulder, and backfill. Gravel will be for use in specified areas between edge of pavement and front of sidewalk as directed by the engineer).					
	65	TONS	\$ _____	_____	\$ _____

**TOTAL OF ADD/ALT UNIT PRICE ITEMS LISTED ABOVE**

\$ \_\_\_\_\_ Dollars and \_\_\_\_\_ Cents  
 (Amount Written in Words has Precedence)



SCALE: 1"=40'

660 SF x 0.5 Ft = 330 CF = 18.2 CY  
 USE 16 CY  
 15 CY = 1.5 TONS = 19.5 TONS

Tree/Species	Botanical Nomenclature	Common Name	Removal/Retain/Relocate
1	<i>Azadirachta indica</i>	Life Oak (Indistiflora)	Remove
4	<i>Coccoloba erecta</i>	Green Buttonwood	Remove
5	<i>Coccoloba erecta</i>	Green Buttonwood	Remove
6	<i>Coccoloba erecta var. sericea</i>	Silver Buttonwood	Remove

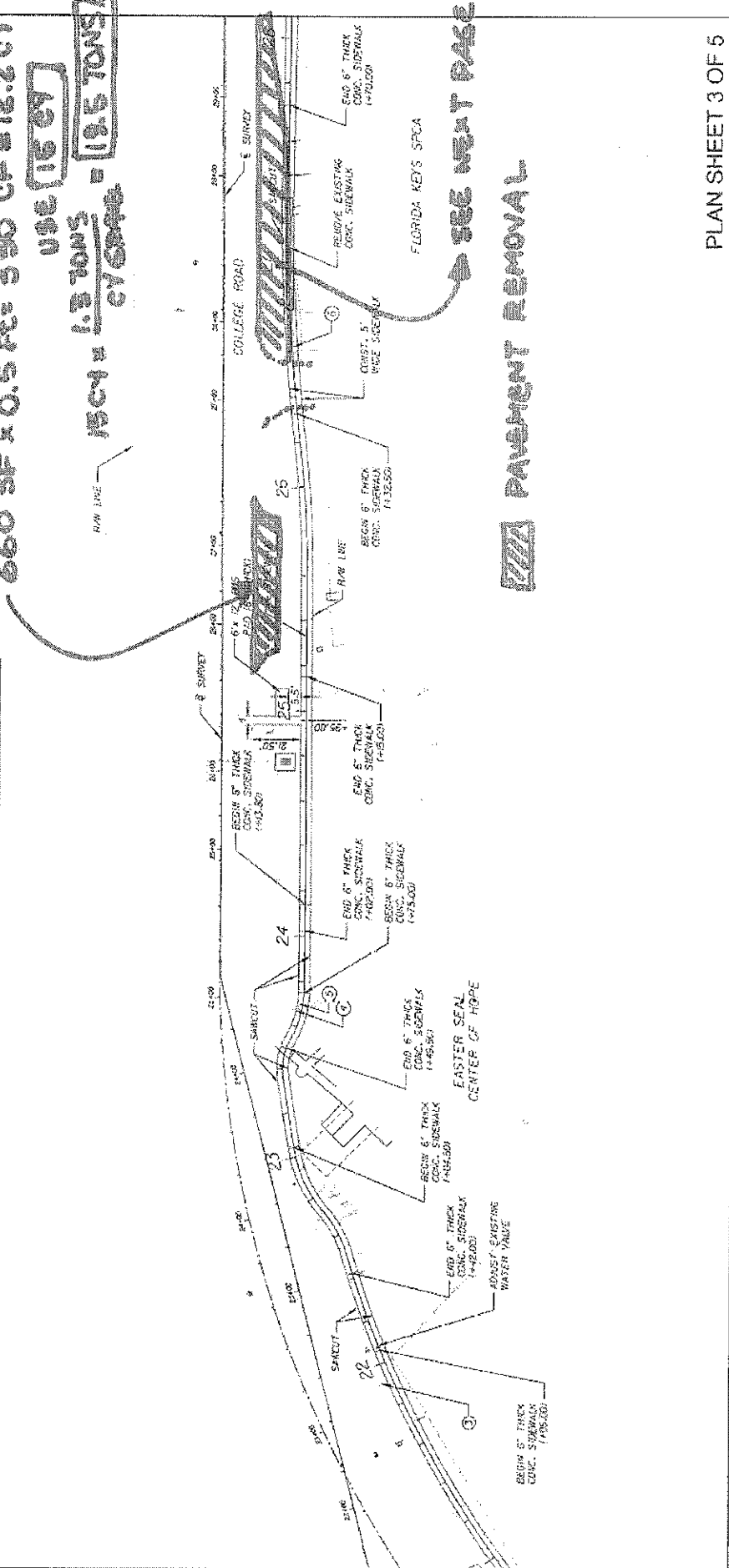

SEE NEXT PAGE  
 PAVEMENT REMOVAL

APPROVED BY: _____ DATE: _____ FRANK L. BOSSY, P.E. REGISTERED ENGINEER NO. 31253 STATE OF FLORIDA		SHEET NO. C-07	
DESCRIPTION: _____ _____ _____ _____		COLLEGE ROAD ENHANCEMENTS	
BERTELLO ALVAREZ & PARTNERS, INC. ARCHITECTURAL - ENGINEERING - PLANNING LANDSCAPE ARCHITECTURE - INTERIOR DESIGN 2801 S. BAYSHORE DRIVE, 3RD FLOOR MIAMI, FL 33133 (305) 853-2660 FAX: (305) 689-3774			
DRAWN: JAY CHECKED: JAY CADD FILE:		PROJECT NO. 2012-0111 FILED # 2012-0111	
CORR. NO.: 1519120 SCALE: 1"=20' DATE: 07/02/12 DRAWN: JAY CHECKED: JAY CADD FILE:		PROJECT NO. 2012-0111 FILED # 2012-0111	

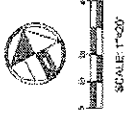

SUNSET MARINA ROAD

1790 SF x 0.5 FEET THICK = 895 CY → USE 35 CY  
 1.0 TONS = 45.5 TONS  
 35 CY x 1.0 TONS = 45.5 TONS

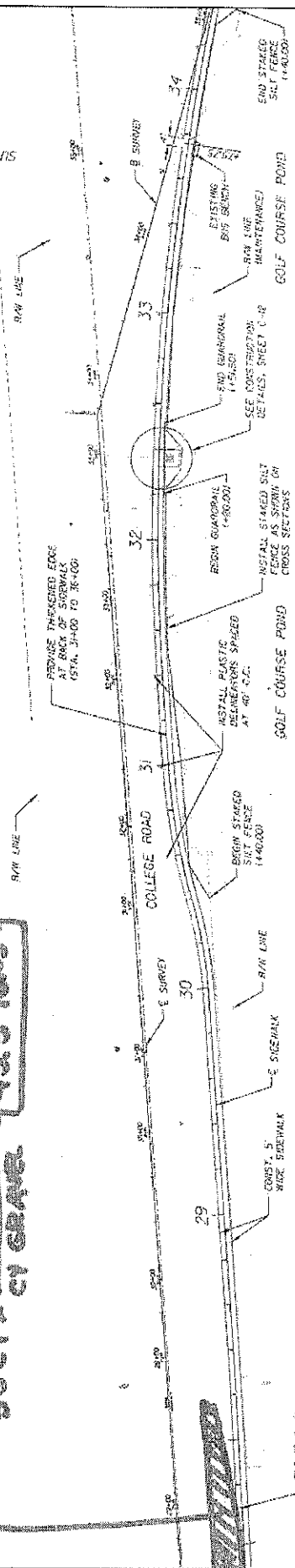

**PAVEMENT REMOVAL** KEY WEST GOLF CLUB

PLAN SHEET 4 OF 5

SHEET NO. <b>C-08</b>	
COLLEGE ROAD ENHANCEMENTS	
PROJECT NO.: 10078205 SCALE: 1" = 30' DATE: 07/02/10 DRAWN BY: JH CHECKED BY: JEN/JAL DATE FILE:	
BERNELO AMMIL & PARTNERS, INC. ARCHITECTURE - ENGINEERING - PLANNING LANDSCAPE ARCHITECTURE - INTERIOR DESIGN 2901 S. SAWSHORE DRIVE, 3RD FLOOR MIAMI FL, 33133 (305) 852-0005 FAX (305) 862-3778	
<b>ba</b>	
APPROVED BY: FRANTZ L. TASSY, P.E. REGISTERED ENGINEER NO. 61955 STATE OF FLORIDA DATE:	REVISIONS: 1. DESCRIPTION: DATE:

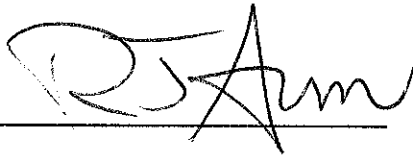

All Bidders shall acknowledge receipt and acceptance of this Addendum NO. 1 by acknowledging Addendum in their proposal or by submitting the addendum with the bid package. Bids submitted without acknowledgement or without this Addendum may be considered non-responsive.

A handwritten signature in black ink, appearing to read "R. J. Am", written over a horizontal line.

**Signature**

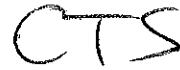
The handwritten letters "CTS" in black ink, written over a horizontal line.

**Name of Business**