



**Historic Architectural Review Commission
Staff Report for Item 7b**

To: Chairman Bryan Green and Historic Architectural Review Commission Members

From: Enid Torregrosa, MSHP
Historic Preservation Planner

Meeting Date: December 15, 2015

Applicant: William P. Horn, Architect

Application Number: H15-01-1677

Address: #1024-1026 Thomas Street

Description of Work:

New one and a half-story frame accessory structure at rear of property.

Site Facts:

The main house in the site is a non-contributing resource to the historic district. The site has three detached structures, the main house, built ca. 1964-1965, a corner ancillary structure, and a carport. All three structures are one-story. The site is located on the northwest corner of Thomas and Virginia Streets. The carport faces Virginia Street.

Ordinances Cited on Review

- Section 102-217 (2), demolition for non-contributing and non-historic structures of the Land Development Regulations.

Staff Analysis

The Certificate of Appropriateness in review is for the demolition of a non-historic and non-contributing carport. The carport is made of cbs walls and its roof is made of wood, covered with metal v-crimp. The structure has several cracks in the walls.

By reviewing the Sanborn maps, it is clear that this specific structure is not historic. It is staff's opinion that the carport cannot qualify as a contributing resource to the historic district in a near future.

The historic architectural review commission shall not issue permits that would result in:

- (1) Removing buildings or structures that are important in defining the overall historic character of a district or neighborhood so that the character is diminished;

It is staff's opinion that the removal of the non-historic carport will not diminish the historic character of the neighborhood.

- (2) Removing historic buildings or structures and thus destroying the historic relationship between buildings or structures and open space;

The carport is not a historic structure.

- (3) Removing an historic building or structure in a complex; or removing a building facade; or removing a significant later addition that is important in defining the historic character of a site or the surrounding district or neighborhood.

The non-historic carport is not a significant structure that defines historic character of the site to which is located.

- (4) Removing buildings or structures that would otherwise qualify as contributing, as set forth in section 102-62(3).

It is staff's opinion that the non-historic carport cannot qualify to be a contributing structure in the historic district.

Consistency with the Ordinance for Demolition

It is staff's opinion that the proposed demolition meets the criteria for demolition of non-historic and non-contributing structures.

APPLICATION

COMBINATION APPLICATION: FLOODPLAIN, CONSTRUCTION AND HARC

\$50.00 APPLICATION FEE NON-REFUNDABLE



City of Key West

3140 FLAGLER AVENUE
KEY WEST, FLORIDA 33040

Phone: 305.809.3956

www.cityofkeywest.fl.gov

HARC PERMIT NUMBER 15-01-1077	BUILDING PERMIT NUMBER 15-4456	INITIAL & DATE DS/15
FLOODPLAIN PERMIT		REVISION #
FLOOD ZONE	PANEL #	ELEV. L. FL.
SUBSTANTIAL IMPROVEMENT		YES NO %

ADDRESS OF PROPOSED PROJECT:

1024 & 1026 THOMAS STREET

OF UNITS

1

RE # OR ALTERNATE KEY:

#2675

NAME ON DEED:

PHONE / IMF

305-293-8983

OWNER'S MAILING ADDRESS:

**1024 & 1026 THOMAS ST.
KEY WEST, FL. 33040**

EMAIL

OWEN@OWENTRAVEL.COM

CONTRACTOR COMPANY NAME:

NA

PHONE NUMBER

CONTRACTOR'S CONTACT PERSON:

EMAIL

ARCHITECT / ENGINEER'S NAME:

WILLIAM P. HOW ARCHITECT, P.A.

PHONE NUMBER

305-296-8302

ARCHITECT / ENGINEER'S ADDRESS:

915 CATON ST.

EMAIL

WPHOW@AOL.COM

HARC: PROJECT LOCATED IN HISTORIC DISTRICT OR IS CONTRIBUTING: YES NO (SEE PART C FOR HARC APPLICATION.)

CONTRACT PRICE FOR PROJECT OR ESTIMATED TOTAL FOR MAT'L., LABOR & PROFIT:

FLORIDA STATUTE 837.06: WHOEVER KNOWINGLY MAKES A FALSE STATEMENT IN WRITING AND WITH THE INTENT TO MISLEAD A PUBLIC SERVANT IN THE PERFORMANCE OF HIS OR HER OFFICIAL DUTY SHALL BE GUILTY OF A MISDEMEANOR OF THE SECOND DEGREE PUNISHABLE PER SECTION 775.082 OR 775.083.

PROJECT TYPE: ONE OR TWO FAMILY MULTI-FAMILY COMMERCIAL NEW REMODEL
 CHANGE OF USE / OCCUPANCY ADDITION SIGNAGE WITHIN FLOOD ZONE **AG+7.0'**
 DEMOLITION SITE WORK INTERIOR EXTERIOR AFTER-THE-FACT

DETAILED PROJECT DESCRIPTION INCLUDING QUANTITIES, SQUARE FOOTAGE ETC.,

ADDITION OF A 1 1/2 STORY ACCESSORY STRUCTURE AT THE REAR OF PROPERTY, DEMOLITION OF CARPORT.

I'VE OBTAINED ALL NECESSARY APPROVALS FROM ASSOCIATIONS, GOVT AGENCIES AND OTHER PARTIES AS APPLICABLE TO COMPLETE THE DESCRIBED PROJECT:	
OWNER PRINT NAME: Owen Trepanier & Richard Pente	QUALIFIER PRINT NAME:
OWNER SIGNATURE: <i>[Signature]</i>	QUALIFIER SIGNATURE:
Notary Signature as to owner: <i>[Signature]</i>	Notary Signature as to qualifier:
STATE OF FLORIDA; COUNTY OF MONROE, SWORN TO AND SCRIBED BEFORE ME THIS 29 DAY OF September , 20 15 .	STATE OF FLORIDA; COUNTY OF MONROE, SWORN TO AND SCRIBED BEFORE ME THIS _____ DAY OF _____, 20 _____.
	Oper: KEYWBLD Type: BP Drawer: Date: 10/28/15 50 Receipt no: 2350 2015 4456 as identification.
Personally known or produced	as identification. Personally known or produced

planning Approved 11/12/15 mto

PT * BUILDING PERMITS-NEW
 1.00 \$50.00
 Trans number: 3071461
 MULTIPLE TENDER
 Trans date: 10/28/15 Time: 7:43:55

41747
 No cr @ Cox...
 34620/3295

PART B: SUPPLEMENTARY PROJECT DETAILS TO AVOID DELAYS / CALL-BACKS

PROPERTY STRUCTURES AFFECTED BY PROJECT: MAIN STRUCTURE ACCESSORY STRUCTURE SITE

ACCESSORY STRUCTURES: GARAGE / CARPORT DECK FENCE OUTBUILDING / SHED

FENCE STRUCTURES: 4 FT. 6 FT. SOLID 6 FT. / TOP 2 FT. 50% OPEN

POOLS: INGROUND ABOVE GROUND SPA / HOT TUB PRIVATE PUBLIC
 PUBLIC POOLS REQUIRE BD. OF HEALTH LICENSE APPLICATION AT TIME OF CITY APPLICATION.
 PUBLIC POOLS REQUIRE BD. OF HEALTH LICENSE PRIOR TO RECEIVING THE CITY CERTIFICATE OF OCCUPANCY.

ROOFING: NEW ROOF-OVER TEAR-OFF REPAIR AWNING
 5 V METAL ASPLT. SHGLS. METAL SHGLS. BLT. UP TPO OTHER

FLORIDA ACCESSIBILITY CODE: 20% OF PROJECT FUNDS INVESTED IN ACCESSIBILITY FEATURES.

SIGNAGE: # OF SINGLE FACE # OF DOUBLE FACE REPLACE SKIN ONLY BOULEVARD ZONE
 POLE WALL PROJECTING AWNING HANGING WINDOW
 SQ. FT. OF EACH SIGN FACE: _____

SUBCONTRACTORS / SPECIALTY CONTRACTORS SUPPLEMENTARY INFORMATION:

MECHANICAL: DUCTWORK COMMERCIAL EXH. HOOD INTAKE / EXH. FANS LPG TANKS
 A / C: COMPLETE SYSTEM AIR HANDLER CONDENSER MINI-SPLIT

ELECTRICAL: LIGHTING RECEPTACLES HOOK-UP EQUIPMENT LOW VOLTAGE
 SERVICE: OVERHEAD UNDERGROUND 1 PHASE 3 PHASE _____ AMPS

PLUMBING: ONE SEWER LATERAL PER BLDG. INGROUND GREASE INTCPTRS. LPG TANKS.
 RESTROOMS: MEN'S WOMEN'S UNISEX ACCESSIBLE

PART C: HARC APPLICATION FOR A CERTIFICATE OF APPROPRIATENESS

APPLICATION FEES: PAINTING SINGLE FAMILY: \$10 STAFF APPROVAL: \$50 COMMISSION REVIEW \$100
 PLEASE ATTACH APPROPRIATE VARIANCES / RESOLUTIONS FROM HARC, PLANNING BOARD OR TREE COMMISSION.
 ATTENTION: NO BUILDING PERMITS WILL BE ISSUED PRIOR TO HARC APPROVAL.

PLEASE SEND ELECTRONIC SUBMISSIONS TO: harc@cityofkeywest-fl.gov

INDICATE TYPE OF CERTIFICATE. OF APPROPRIATENESS: GENERAL DEMOLITION SIGN PAINTING OTHER

ADDITIONAL INFORMATION: _____

PROJECT SPECIFICATIONS: PLEASE PROVIDE PHOTOS OF EXISTING CONDITIONS, PLANS, PRODUCT SAMPLES, TECHNICAL DATA		
ARCHITECTURAL FEATURES TO BE ALTERED:	ORIGINAL MATERIAL:	PROPOSED MATERIAL:
DEMO CAR PORT	MASONRY / WOOD	
NEW ACCESSORY STRUCTURE		WOOD FRAME

DEMOLITION: PLEASE FILL OUT THE HARC APPENDIX FOR PROPOSED DEMOLITION.

DEMOLITION OF HISTORIC STRUCTURES IS NOT ENCOURAGED BY THE HISTORIC ARCHITECTURAL REVIEW COMMISSION.

SIGNAGE: (SEE PART B) BUSINESS SIGN BRAND SIGN OTHER: _____

BUSINESS LICENSE # _____ IF FAÇADE MOUNTED, SQ. FT. OF FAÇADE _____

Open: KEYWBLD Type: BP Drawer: 1
 Date: 10/28/15 50 Receipt no: 2350
 2015 1001677
 PT * BUILDING PERMITS-NEW
 1.00 \$100.00
 Trans number: 3071450
 MULTIPLE TENDER
 Trans date: 10/28/15 Time: 7:43:55

SIGN SPECIFICATIONS		
SIGN COPY:	PROPOSED MATERIALS:	SIGNS WITH ILLUMINATION:
		TYPE OF LTG.:
		LTG. LINEAL FTG.:
MAX. HGT. OF FONTS:		COLOR AND TOTAL LUMENS:
IF USING LIGHT FIXTURES PLEASE INDICATE HOW MANY: INCLUDE SPEC. SHEET WITH LOCATIONS AND COLORS.		

OFFICIAL USE ONLY: HARC STAFF OR COMMISSION REVIEW		
<input type="checkbox"/> APPROVED / <input type="checkbox"/> NOT APPROVED / <input type="checkbox"/> DEFERRED FOR FUTURE CONSIDERATION / <input type="checkbox"/> TABLED FOR ADD'L. INFO.		
HARC MEETING DATE:	HARC MEETING DATE:	HARC MEETING DATE:
REASONS OR CONDITIONS:		
STAFF REVIEW COMMENTS:		
<i>Main building on site is not contributing. Guidelines for accessory structures / new construction.</i>		
HARC PLANNER SIGNATURE AND DATE:		HARC CHAIRPERSON SIGNATURE AND DATE:

PART D: STATE OF FLORIDA OFFICIAL NOTIFICATIONS AND WARNINGS

FLORIDA STATUTE 713.135: WARNING TO OWNER: YOUR FAILURE TO RECORD A 'NOTICE OF COMMENCEMENT' MAY RESULT IN YOUR PAYING TWICE FOR IMPROVEMENTS TO YOUR PROPERTY. A NOTICE OF COMMENCEMENT MUST BE RECORDED WITH THE COUNTY RECORDER AND A COPY POSTED ON THE JOB SITE BEFORE THE FIRST INSPECTION. IF YOU INTEND TO OBTAIN FINANCING CONSULT WITH YOUR LENDER OR AN ATTORNEY BEFORE RECORDING A NOTICE.

FLORIDA STATUTE 469: ABESTOS ABATEMENT. AS OWNER / CONTRACTOR / AGENT OF RECORD FOR THE CONSTRUCTION APPLIED FOR IN THIS APPLICATION, I AGREE THAT I WILL COMPLY WITH THE PROVISIONS F. S. 469.003 AND TO NOTIFY THE FLORIDA D. E. P. OF MY INTENT TO DEMOLISH / REMOVE ASBESTOS. IN ADDITION TO THE REQUIREMENTS OF THIS PERMIT APPLICATION, THERE MAY BE DEED RESTRICTIONS AND / OR ADDITIONAL RESTRICTIONS APPLICABLE TO THIS PROPERTY THAT MAY BE FOUND IN THE PUBLIC RECORDS OF MONROE COUNTY AND THERE MAY BE ADDITIONAL PERMITS REQUIRED FROM OTHER GOVERNMENT ENTITIES SUCH AS AQUADUCT ATHORITY, FLORIDA DEP OR OTHER STATE AGENCIES; ARMY CORPS OF ENGINEERS OR OTHER FEDERAL AGENCIES.

FEDERAL LAW REQUIRES LEAD PAINT ABATEMENT PER THE STANDARDS OF THE USDEP ON STRUCTURES BUILT PRIOR TO 1978.

OFFICIAL USE ONLY BY PLANS EXAMINER OR CHIEF BUILDING OFFICIAL:				CBO OR PL. EXAM. APPROVAL:
HARC FEES:	BLDG. FEES:	FIRE MARSHAL FEE:	IMPACT FEES:	
				DATE:



CITY OF KEY WEST
CERTIFICATE OF APPROPRIATENESS
APPENDIX FOR DEMOLITIONS
 APPLICATION NUMBER H- H-15-01-1077
1024 + 1026 THOMAS STREET

This document applies only to those properties located within the City of Key West Historic Zoning Districts, properties outside the historic zoning districts which are listed as contributing in the Historic Architectural Survey and or properties listed in the National Register of Historic Places.

Applications must meet or exceed the requirements outlined by the Secretary of the Interior's Standards for Rehabilitation and Guidelines for Rehabilitation and the Key West's Historic Architectural Guidelines. Once submitted, the application shall be reviewed by staff for completeness and scheduled for presentation to the Historic Architectural Review Commission for the next available meeting, unless the demolition request is for a *bona fide* Code Compliance case, in which case staff may review and approve the demolition request. **The applicant must be present at this meeting. Any person that makes changes to an approved Certificate of Appropriateness must submit a new application with such modifications.**

The filing of this application does not ensure approval as submitted. Applications that do not possess the required submittals or documentation will be considered incomplete and will not be reviewed for approval.

CRITERIA FOR DEMOLITIONS

Before any Certificate of Appropriateness may be issued for a demolition request, the Historic Architectural Review Commission must find that the following requirements are met (please review and comment on each criterion that applies):

- (1) If the subject of the application is a contributing or historic building or structure, then it should not be demolished unless its condition is irrevocably compromised by extreme deterioration or it does not meet any of the following criteria:
 - (a) The existing condition of the building or structure is irrevocably compromised by extreme deterioration.

OR THAT THE BUILDING OR STRUCTURE;

- (a) Embodies no distinctive characteristics of a type, period, or method of construction of aesthetic or historic significance in the city and is not a significant and distinguishable building entity whose components may lack individual distinction.
THE STRUCTURE IS A CONCRETE BLOCK + PLYWOOD CARPORT THAT IS NOT HISTORIC. THE PLYWOOD IS ROTTING AND THE CONCRETE IS SPALLING.
- (b) Is not specifically associated with events that have made a significant contribution to local, state, or national history.
N/A

- (c) Has no significant character, interest, or value as part of the development, heritage, or cultural characteristics of the city, state or nation, and is not associated with the life of a person significant in the past.

N/A

- (d) Is not the site of a historic event with a significant effect upon society.

N/A

- (e) Does not exemplify the cultural, political, economic, social, or historic heritage of the city.

N/A

- (f) Does not portray the environment in an era of history characterized by a distinctive architectural style.

N/A

- (g) If a part of or related to a square, park, or other distinctive area, nevertheless should not be developed or preserved according to a plan based on the area's historic, cultural, natural, or architectural motif.

N/A

- (h) Does not have a unique location or singular physical characteristic which represents an established and familiar visual feature of its neighborhood or of the city, and does not exemplify the best remaining architectural type in a neighborhood.

N/A

- (i) Has not yielded, and is not likely to yield, information important in history.

N/A

CITY OF KEY WEST
CERTIFICATE OF APPROPRIATENESS
APPENDIX FOR DEMOLITIONS
APPLICATION NUMBER H- _____



(2) For a contributing historic or noncontributing building or structure, a complete construction plan for the site is approved by the Historic Architectural Review Commission.

(a) A complete construction plan for the site is included in this application

____ Yes Number of pages and date on plans _____

No Reason HARC DESIGN DRAWINGS

The following criteria will also be reviewed by the Historic Architectural Review Commission for proposed demolitions. The Commission shall not issue a Certificate of Appropriateness that would result in the following conditions (please review and comment on each criterion that applies):

(1) Removing buildings or structures that are important in defining the overall historic character of a district or neighborhood so that the character is diminished.

THIS IS A NON-HISTORIC CARPORT THAT IS FALLING DOWN.

(2) Removing historic buildings or structures and thus destroying the historic relationship between buildings or structures and open space; and

N/A

AND

(3) Removing an historic building or structure in a complex; or removing a building facade; or removing a significant later addition that is important in defining the historic character of a site or the surrounding district or neighborhood.

N/A

(4) Removing buildings or structures that would otherwise qualify as contributing.

N/A

Nothing in this application is intended to alter the authority of the Building Official to condemn for demolition dangerous buildings, as provided in Section 102-218 of the Land Development Regulations and Chapter 14 of the Code of Ordinances.

*I hereby certify I am the owner of record and that the work shall conform to all applicable laws of this jurisdiction. By receiving a Certificate of Appropriateness, I realize that this project will require a Building Permit, approval **PRIOR** to proceeding with the work outlined above and that there will be a final inspection required under this application. I also understand that any changes to an approved Certificate of Appropriateness must be submitted for review.*

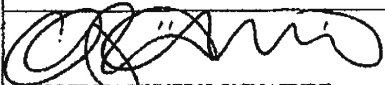
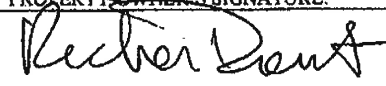
 PROPERTY OWNER'S SIGNATURE:	10/27/15 Owen Trepanier DATE AND PRINT NAME:
	10-27-15 Richard Poente

OFFICE USE ONLY

BUILDING DESCRIPTION:			
<input type="checkbox"/> Contributing	Year built _____	Style _____	Listed in the NRHP _____ Year _____
<input type="checkbox"/> Not listed	Year built _____	Comments _____	

<input type="checkbox"/> Reviewed by Staff on _____ <input type="checkbox"/> Notice of hearing posted _____ First reading meeting date _____ Second Reading meeting date _____ TWO YEAR EXPIRATION DATE _____	Staff Comments
--	------------------------------------

SANBORN MAPS

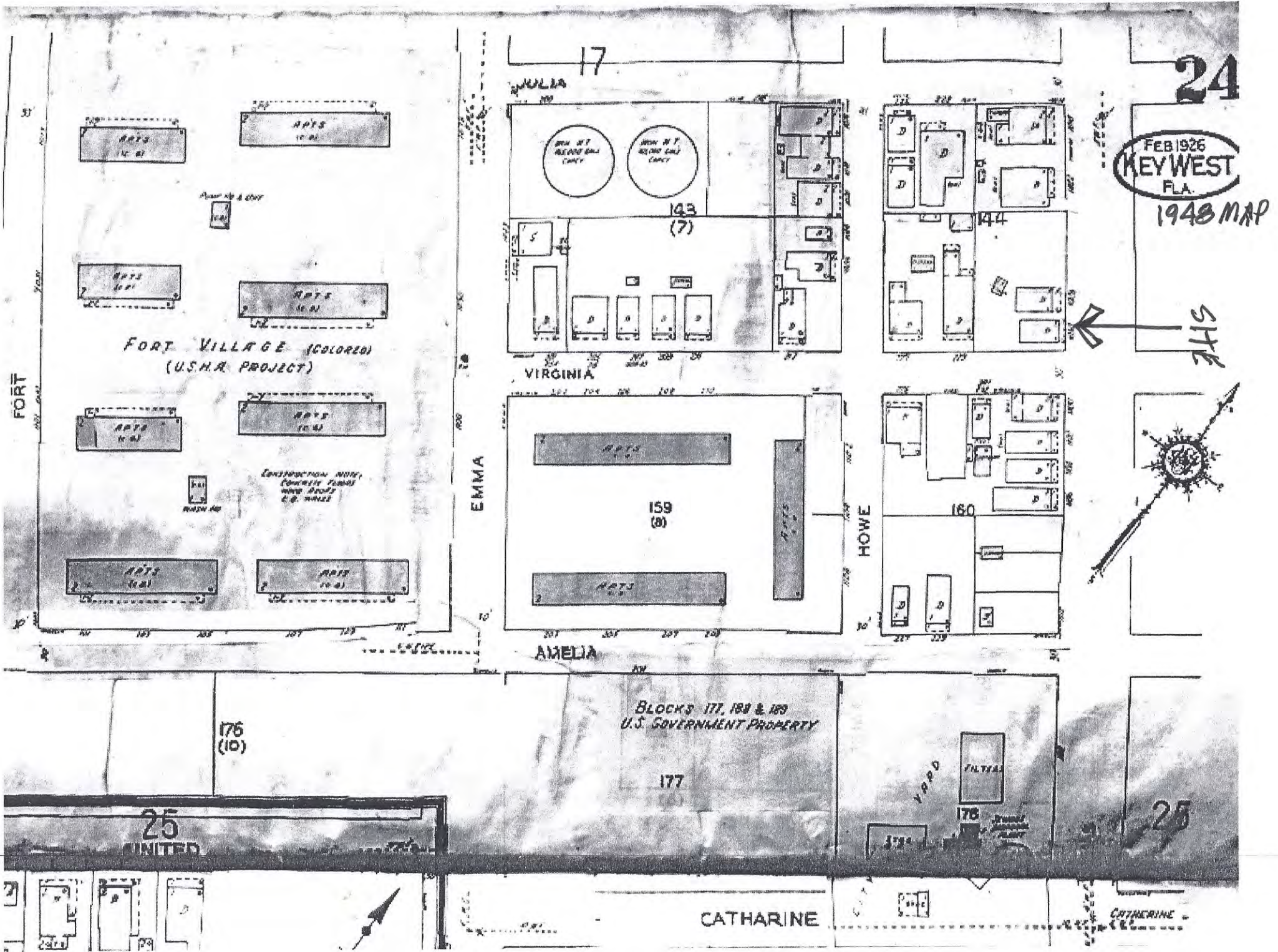

FEB 1926
KEY WEST
FLA.

1948 MAP

← SITE

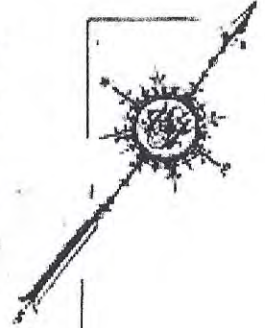

17

24

FORT VILLAGE (COLORED)
(U.S.A. PROJECT)

VIRGINIA

EMMA

HOWE

AMELIA

CATHARINE

CATHERINE

176
(10)

25
UNITED

BLOCKS 177, 188 & 189
U.S. GOVERNMENT PROPERTY

177

178

25

CONSTRUCTION NOTE:
Concrete Foundations
with roofs
e.g. walls

NEW W.P.
RESIDUAL ONLY
CANTY

NEW W.P.
RESIDUAL ONLY
CANTY

173
(7)

174

159
(8)

160

APTS
15-21

APTS
16-21

APTS
16-21

APTS
16-21

APTS
16-21

APTS
16-21

APTS
16-21

APTS
16-21

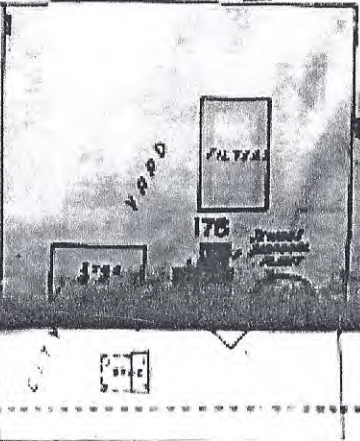
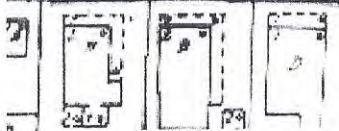
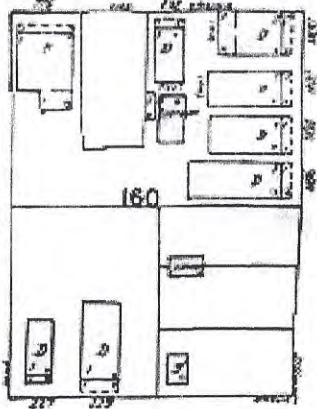
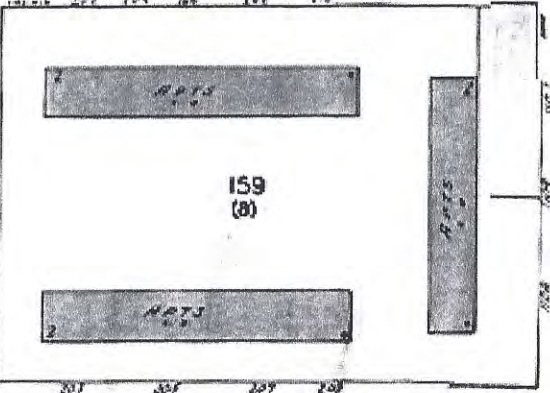
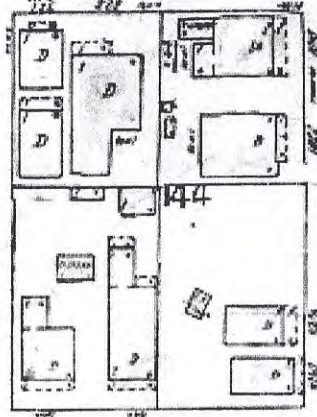
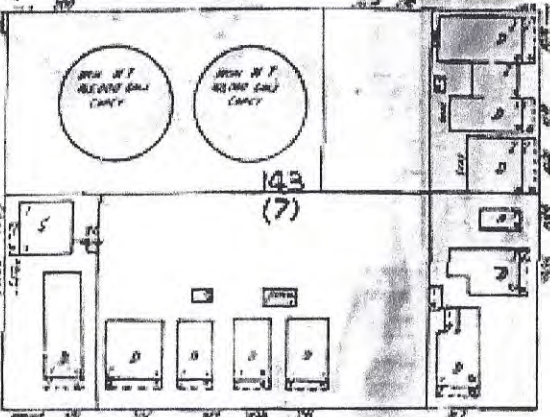

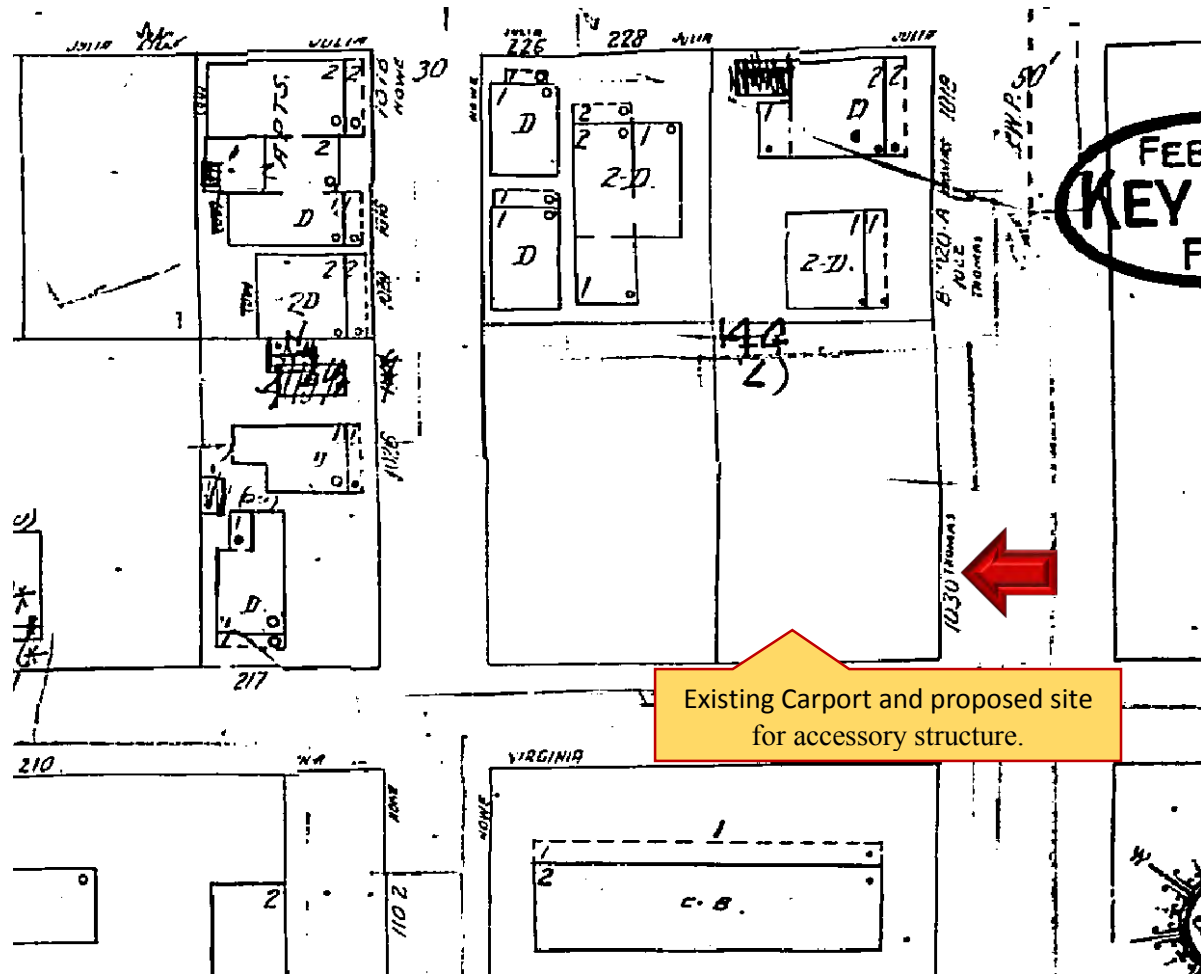

#1024-1026 Thomas Street Sanborn map 1962

PROJECT PHOTOS

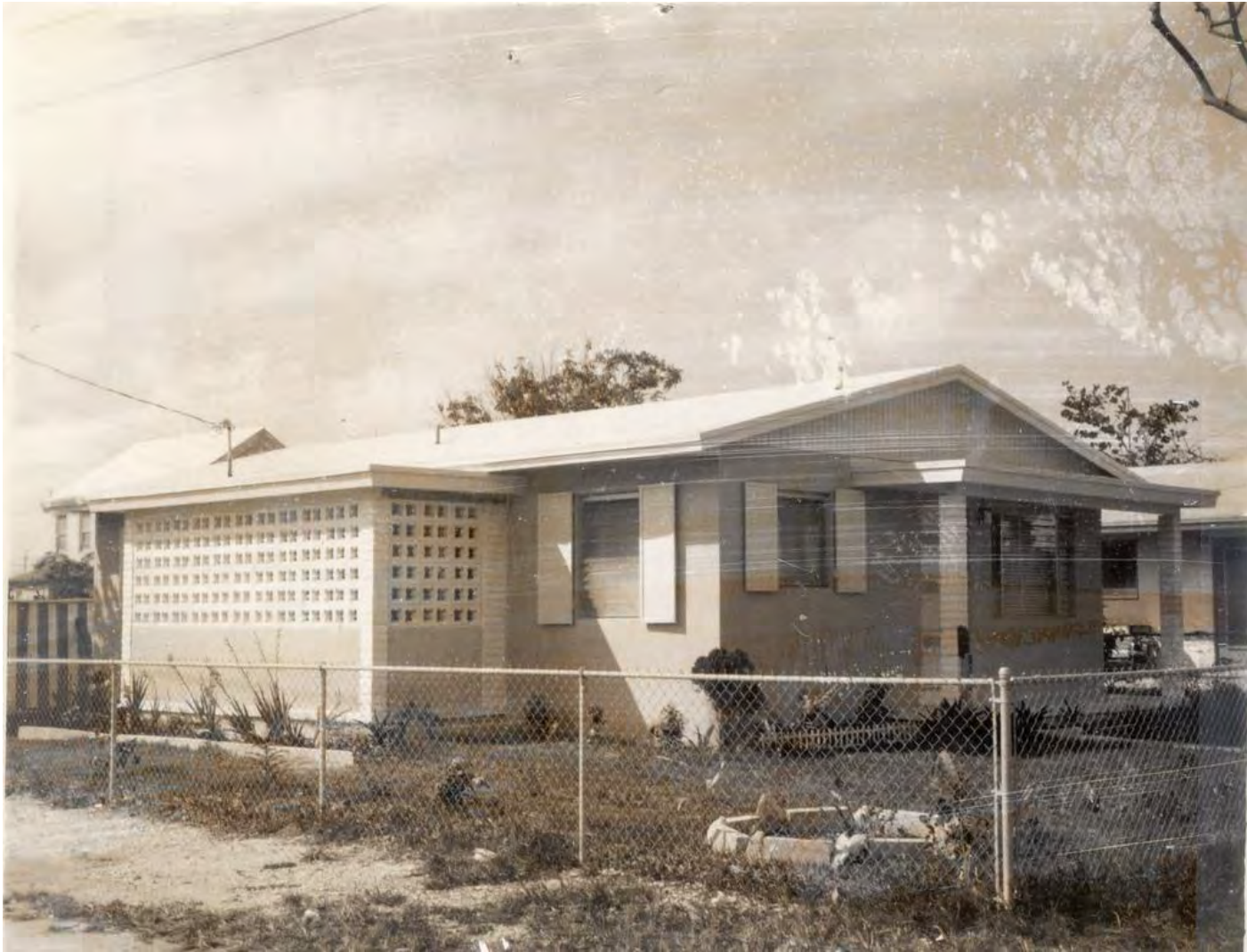

#1024 Thomas Street circa 1965. Monroe County Library.



VIEW FROM THOMAS ST.

WILLIAM P. HORN ARCHITECT, PA.

915 EATON ST., KEY WEST, FL. 33040 TEL. 305-296-8302 WWW.WILLIAMPHORNARCHITECTPA.COM

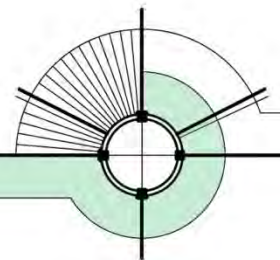



SURROUNDINGS

WILLIAM P. HORN ARCHITECT, PA.

915 EATON ST., KEY WEST, FL. 33040 TEL. 305-296-8302 WWW.WILLIAMPHORNARCHITECTPA.COM

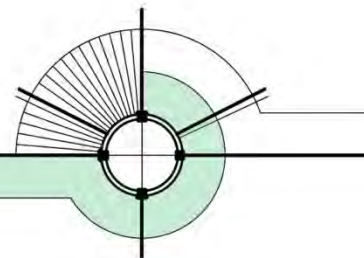



VIEW FROM THOMAS ST.

WILLIAM P. HORN ARCHITECT, PA.

915 EATON ST., KEY WEST, FL. 33040 TEL. 305-296-8302 WWW.WILLIAMPHORNARCHITECTPA.COM

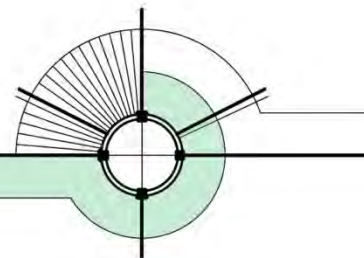



VIEW FROM VIRGINIA ST.

WILLIAM P. HORN ARCHITECT, PA.

915 EATON ST., KEY WEST, FL. 33040 TEL. 305-296-8302 WWW.WILLIAMPHORNARCHITECTPA.COM

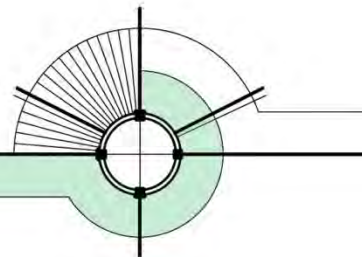



VIEW FROM VIRGINIA ST.

WILLIAM P. HORN ARCHITECT, PA.

915 EATON ST., KEY WEST, FL. 33040 TEL. 305-296-8302 WWW.WILLIAMPHORNARCHITECTPA.COM

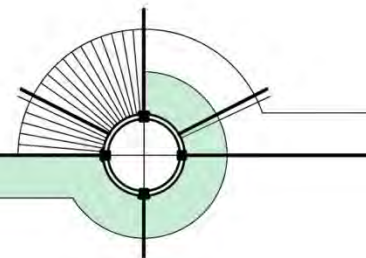



SURROUNDINGS

WILLIAM P. HORN ARCHITECT, PA.

915 EATON ST., KEY WEST, FL. 33040 TEL. 305-296-8302 WWW.WILLIAMPHORNARCHITECTPA.COM

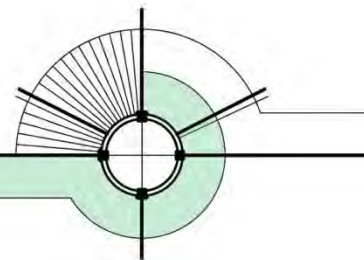



SURROUNDINGS

WILLIAM P. HORN ARCHITECT, PA.

915 EATON ST., KEY WEST, FL. 33040 TEL. 305-296-8302 WWW.WILLIAMPHORNARCHITECTPA.COM

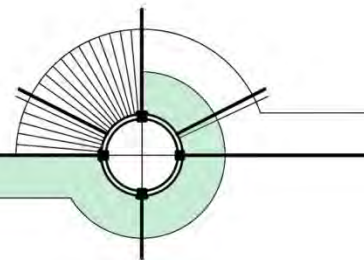

SURVEY

Boundary Survey Map of part of Lots 7 & 8, Square 6, Tract 10, Island of Key West, Florida

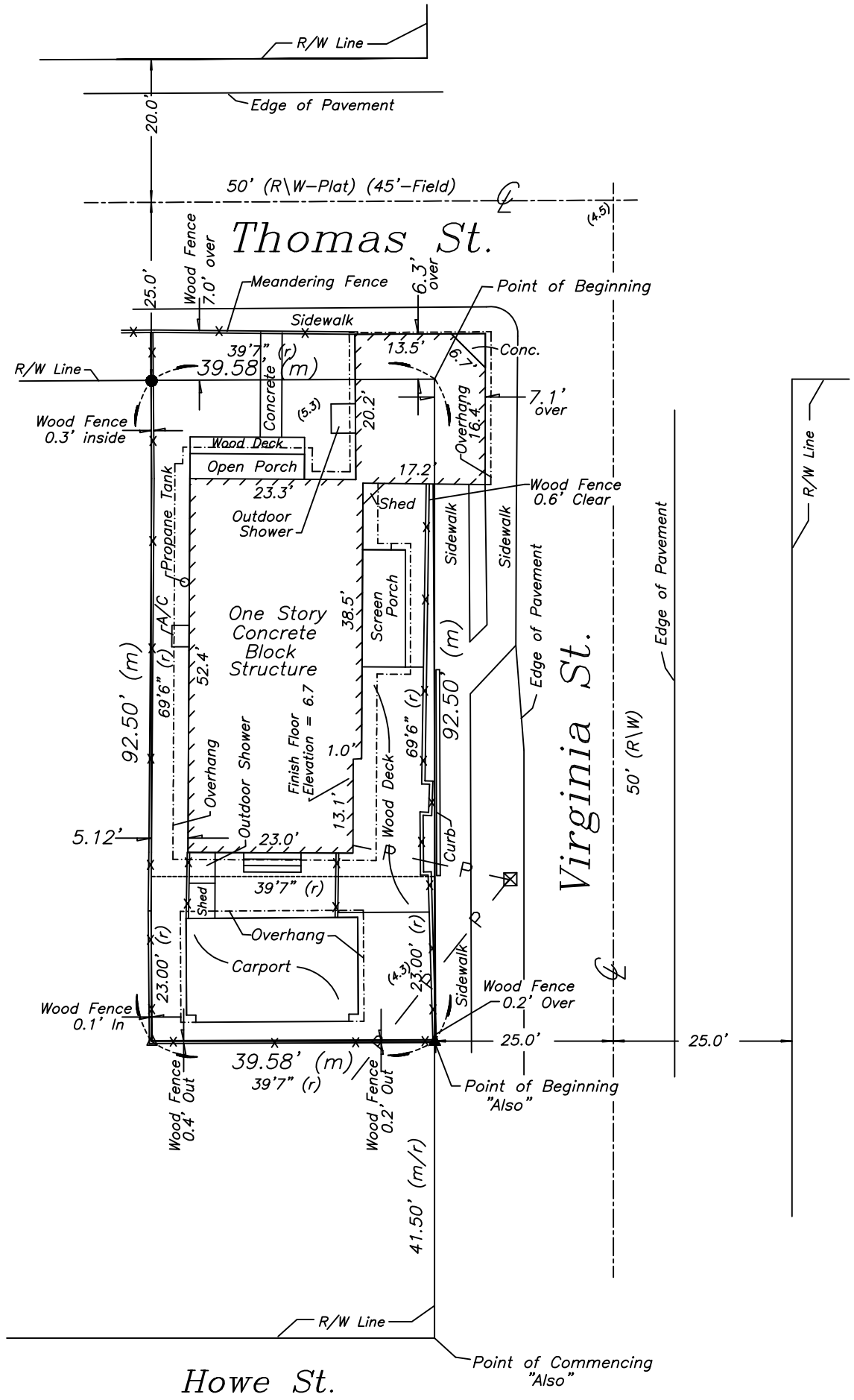
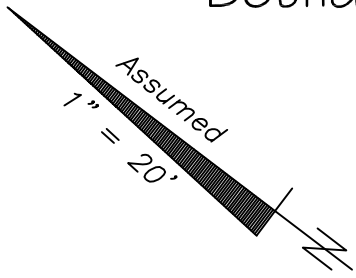

LEGEND

- ⊙ Found 1" Iron Pipe (No ID)
- Set 3/4" Iron Pipe w/cap (6298)
- Found 1/2" Iron Rod (RER)
- ▲ Found Nail & Disc (6298)
- △ Set Nail & Disc (6298)
- (M) Measured
- (R) Record
- (M/R) Measured & Record
- C.B.S. Concrete Block Structure
- R\W Right of Way
- CLF Chain Link Fence
- ⊕ Centerline
- ⊗ Wood Utility Pole
- ⊠ Concrete Utility Pole
- P- Overhead Utility Lines
- (4.5) Spot Elevation (Typical)

Note:
This Survey Map is not full
and complete without the
attached Survey Report.

Sheet One of Two Sheets

J. LYNN O'FLYNN, Inc.



Professional Surveyor & Mapper
PSM #6298

3430 Duck Ave., Key West, FL 33040
(305) 296-7422 FAX (305) 296-2244

Boundary Survey Report of part of Lots 7 & 8, Square 6,
Tract 10, Island of Key West, Florida

NOTES:

1. The legal descriptions shown hereon were furnished by the client or their agent.
2. Underground foundations and utilities were not located.
3. All angles are 90° (Measured & Record) unless otherwise noted.
4. Street address: 1024 & 1026 Thomas Street, Key West, FL.
5. This survey is not valid without the signature and the original raised seal of a Florida licensed surveyor and mapper.
6. Lands shown hereon were not abstracted for rights-of-way, easements, ownership, or other instruments of record.
7. North Arrow is assumed and based on the legal description.
8. Adjoiners are not furnished.
9. Date of field work: June 30, 2015 and August 31, 2015.
10. Ownership of fences is undeterminable, unless otherwise noted.
11. Elevations are shown in parenthesis and refer to Mean Sea Level, N.G.V.D. 1929 Datum.
12. Benchmark utilized: BASIC
13. Flood Insurance Rate Map Zone: AE (EL 7); Community Panel #120168; 1516 K, 2-18-05.

BOUNDARY SURVEY OF: All that lot or parcel of land situate, lying and being in the City of Key West, County of Monroe, and State of Florida, known on William A. Whitehead's map of said Island of Key West delineated in February, A.D. 1829, as a part of Tract 10, but better known and described by a diagram made by E.C. Howe of said Tract 10 as part of Lot 7 in Square 6 and more particularly described as commencing at the corner of Thomas and Virginia Streets and running thence in a NW'ly direction along Thomas Street 39 feet and 7 inches; thence at right angles in a SW'ly direction 69 feet and 6 inches; thence at right angles in a SE'ly direction 39 feet and 7 inches to the NW'ly side of Virginia Street; thence in a NE'ly direction along the NW'ly side of Virginia Street to the said corner, the Point or Place of Beginning.

ALSO

On the Island of Key West and known as part of Lot 8 in Square 6 of Tract 10 according to C.W. Tift's map of the City of Key West, Florida, delineated in 1874; Commence at the intersection of the Northeasterly right of way line of Howe Street and the Northwesterly right of way line of Virginia Street; thence in a Northeasterly direction along the said right of way line of Virginia Street for 41.50 feet to the Point of Beginning; thence continue in a Northeasterly direction along the said Northwesterly right of way line of Virginia Street for 23.00 feet; thence at right angles in a Northwesterly direction for a distance of 39.58 feet; thence at right angles in a Southwesterly direction for 23.00 feet; thence at right angles and in a Southeasterly direction for 39.58 feet to the said Northwesterly right of way line of Virginia Street and the Point of Beginning.

BOUNDARY SURVEY FOR: Owen John Trepanier and Richard Puente;

I HEREBY CERTIFY that this survey was made under my responsible charge and meets the Standard of Practice as set forth by the Florida Board of Professional Surveyors & Mappers in Chapter 5J-17, Florida Administrative Code, pursuant to Section 472.027, Florida Statutes.

J. LYNN O'FLYNN, INC.

J. Lynn O'Flynn, PSM
Florida Reg. #6298

June 30, 2015
Updated 8/31/15 to add elevations and overhangs
Updated 9/9/15 to add flood zone

Sheet Two of Two Sheets

J. LYNN O'FLYNN, Inc.

Professional Surveyor & Mapper
PSM #6298
3430 Duck Ave., Key West, FL 33040
(305) 296-7422 FAX (305) 296-2244

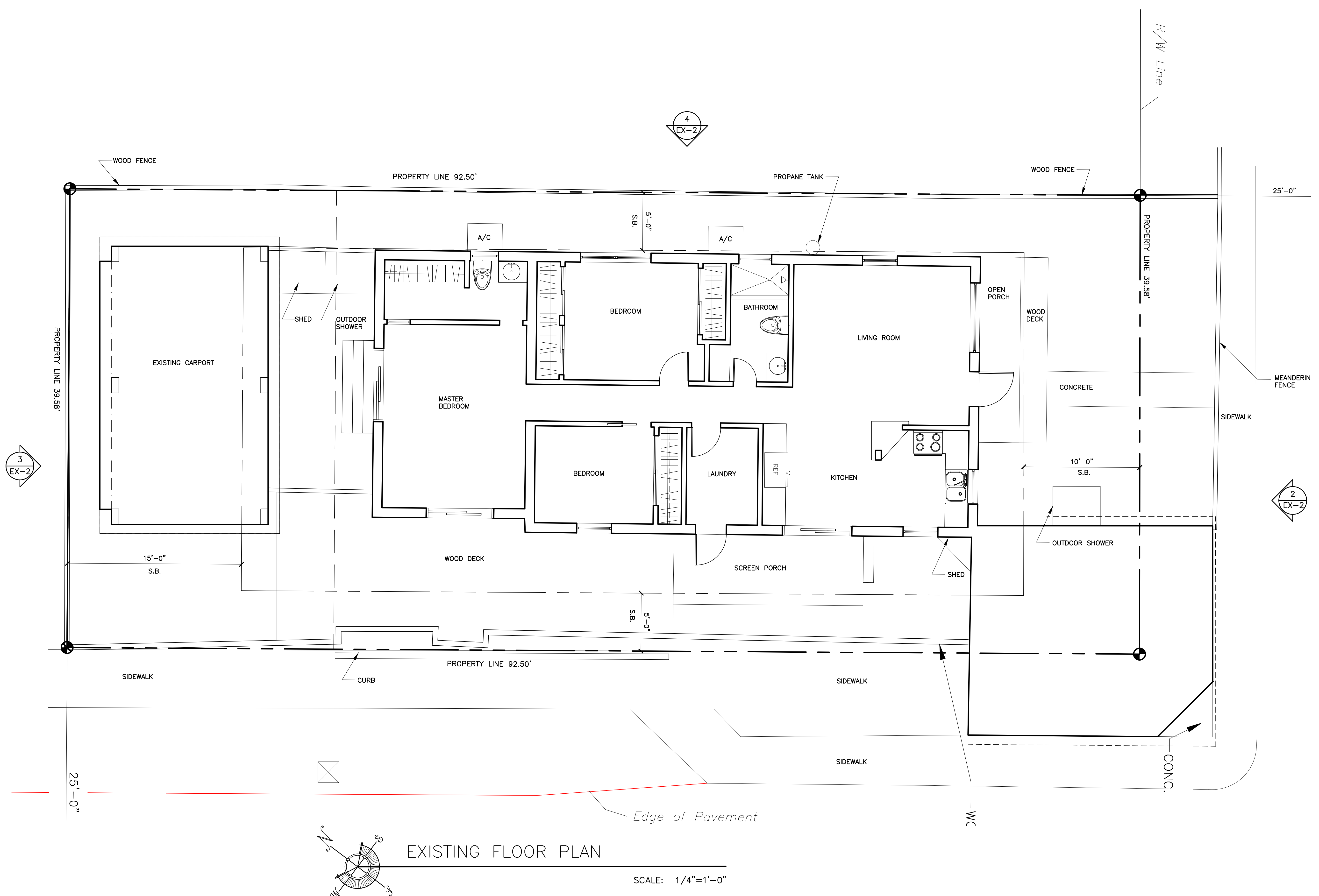
PROPOSED DESIGN



3
EX-2

4
EX-2

2
EX-2

SEAL

DATE
07-13-15

REVISIONS

DRAWN BY
JW

PROJECT NUMBER
1517

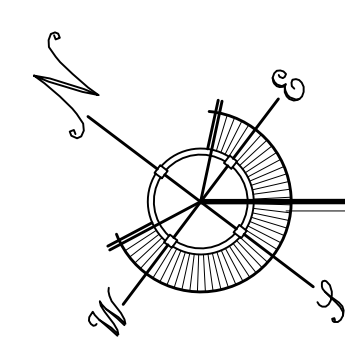

EXISTING FLOOR PLAN

SCALE: 1/4"=1'-0"

PUENTE-TREPANIER RESIDENCE

1024 & 1026 THOMAS STREET
KEY WEST, FLORIDA

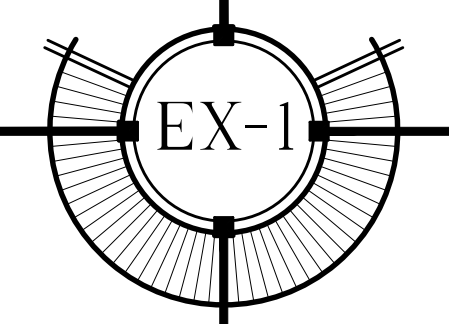

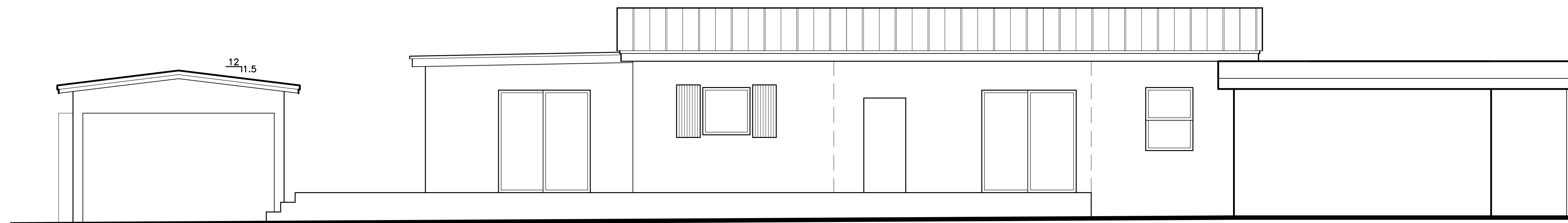

1
EX-2
EXISTING SIDE ELEVATION

SCALE: 1/4"=1'-0"

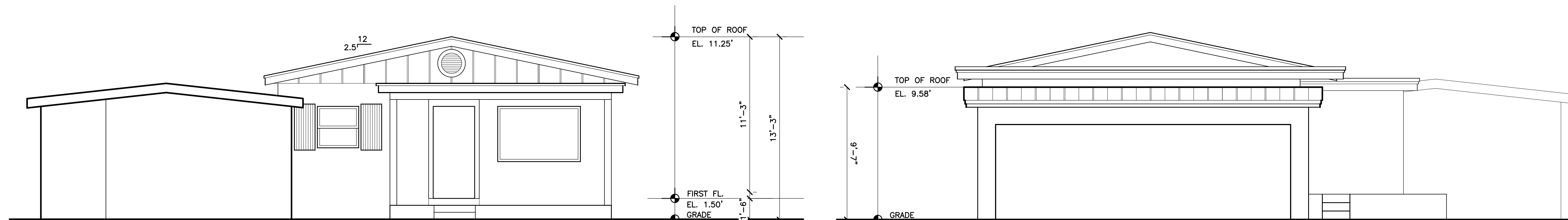

2
EX-2
EXISTING FRONT ELEVATION

SCALE: 1/4"=1'-0"

3
EX-2
EXISTING REAR ELEVATION

SCALE: 1/4"=1'-0"

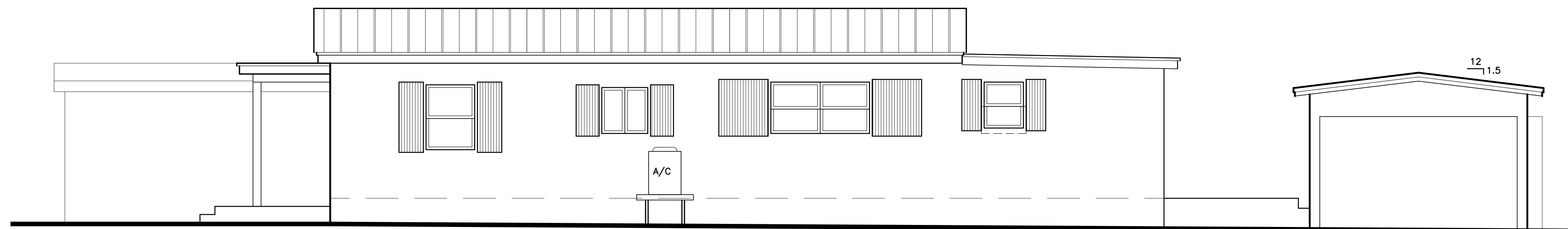

4
EX-2
EXISTING SIDE ELEVATION

SCALE: 1/4"=1'-0"

SEAL

DATE
07-13-15

REVISIONS

DRAWN BY
JW

PROJECT
NUMBER
1517

PUENTE-TREPANIER RESIDENCE

1024 & 1026 THOMAS STREET
KEY WEST, FLORIDA

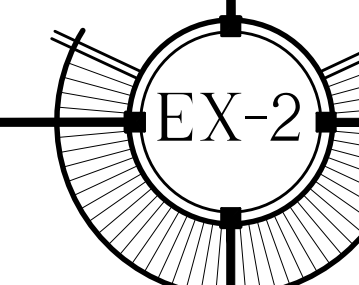

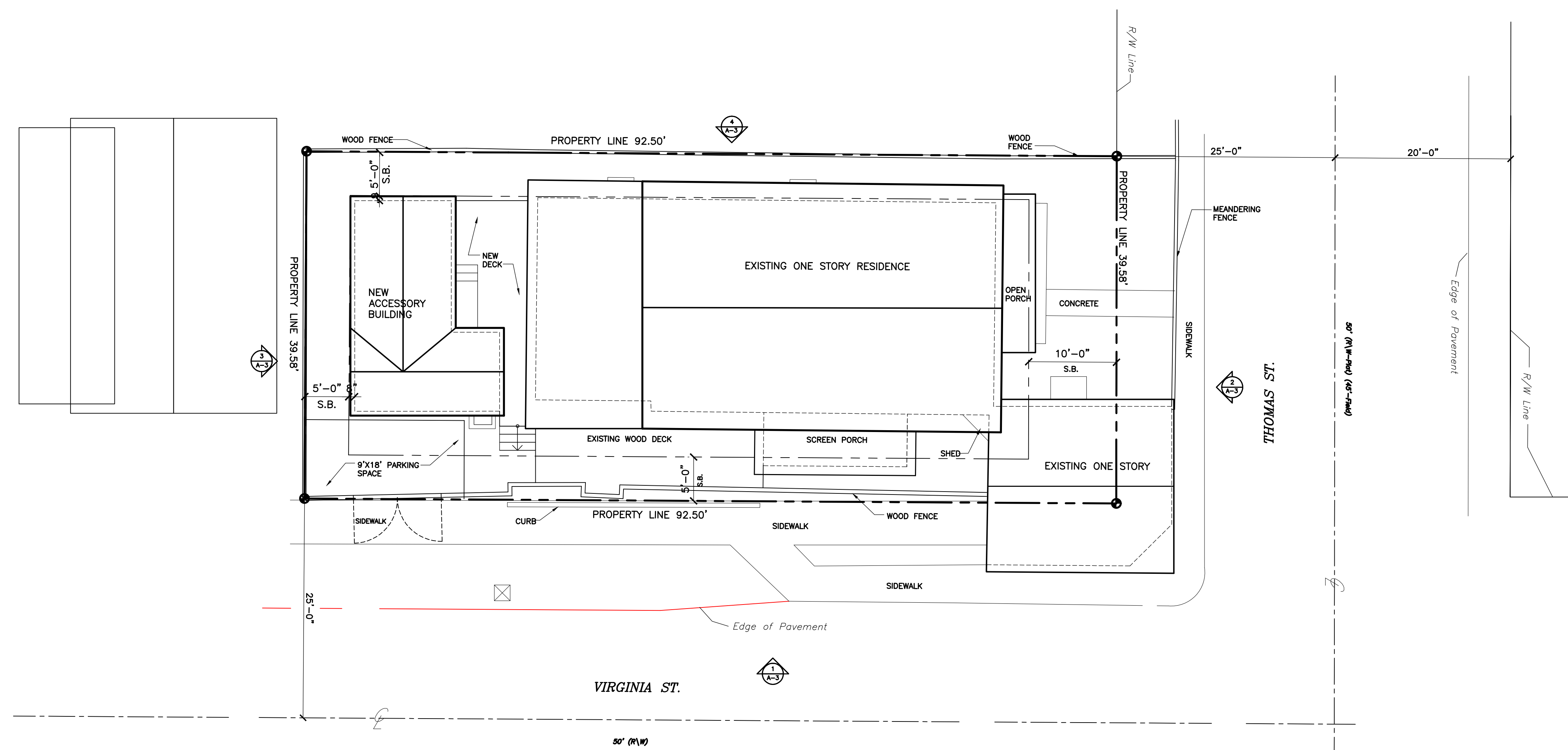

SITE DATA	
LAND USE	: HMDR
FLOOD ZONE	: ZONE 'AE' +7.0'
SITE AREA	: 3,661.15 S.F. (0.084 ACRES)
HEIGHT	: ALLOWED = 30' MAX. EXISTING = 13'-3" PROPOSED = 19'-1"
SETBACKS	:
FRONT SETBACK:	REQUIRED = 10'-0" EXISTING = 0'-0" PROPOSED = 0'-0"
SIDE SETBACK:	REQUIRED = 5'-0" EXISTING = 3'-3" PROPOSED = 3'-3"
STREET SIDE:	REQUIRED = 7'-6" EXISTING = 0'-0" PROPOSED = 0'-0"
REAR SETBACK:	REQUIRED = 15'-0" EXISTING = 2'-8" PROPOSED = 5'-0"
LOT COVERAGE AREA:	
ALLOWED	: 7,608 S.F. (40% MAX.)
EXISTING	: 2,286 S.F. (62%)
PROPOSED	: 2,219 S.F. (60%)
IMPERVIOUS AREA:	
ALLOWED	: 11,411 S.F. (60% MAX.)
EXISTING	: 2,450.5 S.F. (67%)
PROPOSED	: 2,405.5 S.F. (66%)
LANDSCAPE AREA:	
REQUIRED	: 6,656 S.F. (35% MIN.)
EXISTING	: 1,070.15 S.F. (29%)
PROPOSED	: 1,093.15 S.F. (30%)
OPEN SPACE AREA:	
REQUIRED	: 6,656 S.F. (35% MIN.)
EXISTING	: 1,070.15 S.F. (29%)
PROPOSED	: 1,093.15 S.F. (30%)
PARKING	: 1 SPACE PER UNIT

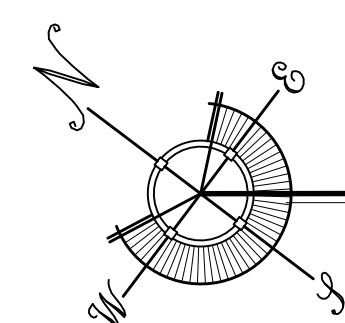

PROPOSED ROOF PLAN

SCALE: 1/8"=1'-0"

SEAL

DATE
07-13-15
10-01-15 HARC

REVISIONS

DRAWN BY
JW
EMA
PROJECT NUMBER
1517

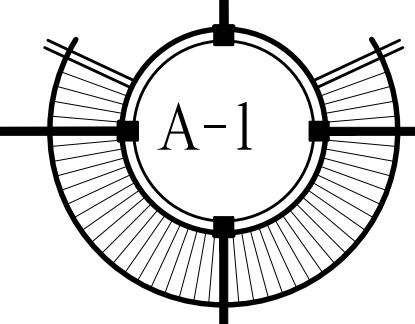

PUENTE-TREPANIER RESIDENCE

1024 & 1026 THOMAS STREET
KEY WEST, FLORIDA

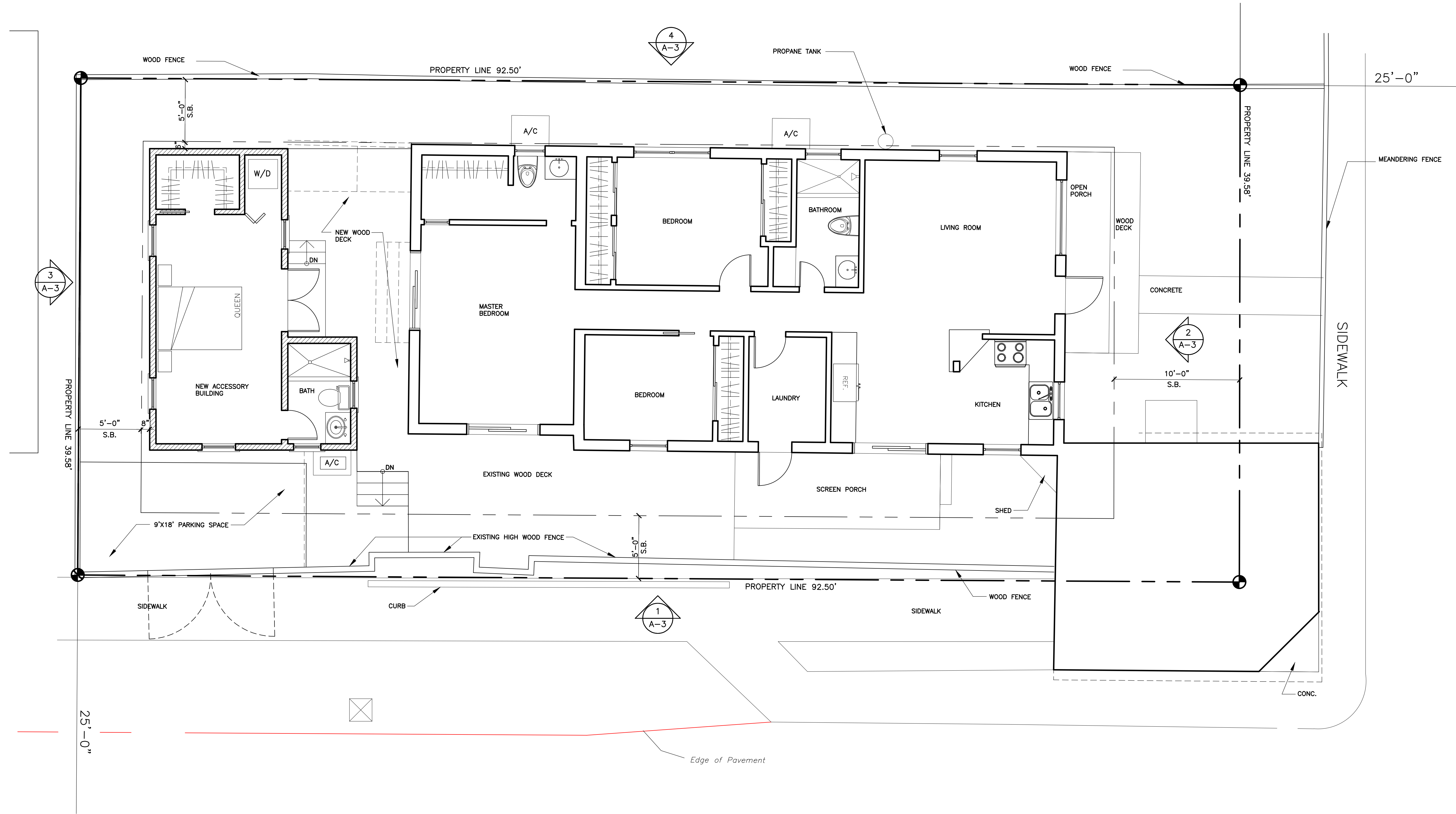

SEAL _____

DATE
07-13-15
10-01-15 HARC

REVISIONS _____

DRAWN BY
JW
EMA
PROJECT NUMBER
1517

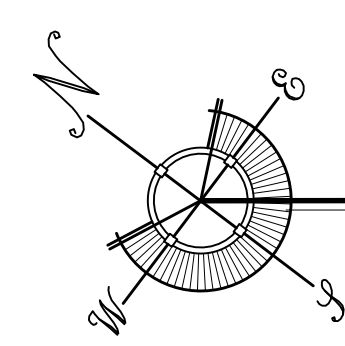

PROPOSED PLAN

SCALE: 1/4"=1'-0"

WALL LEGEND	
	EXISTING WALL CONST.
	NEW WALL
	EXISTING TO BE REMOVED

PUENTE-TREPANIER RESIDENCE

1024 & 1026 THOMAS STREET
KEY WEST, FLORIDA

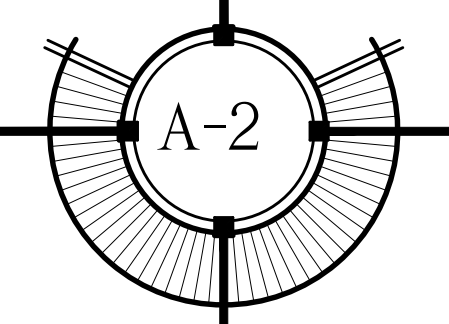

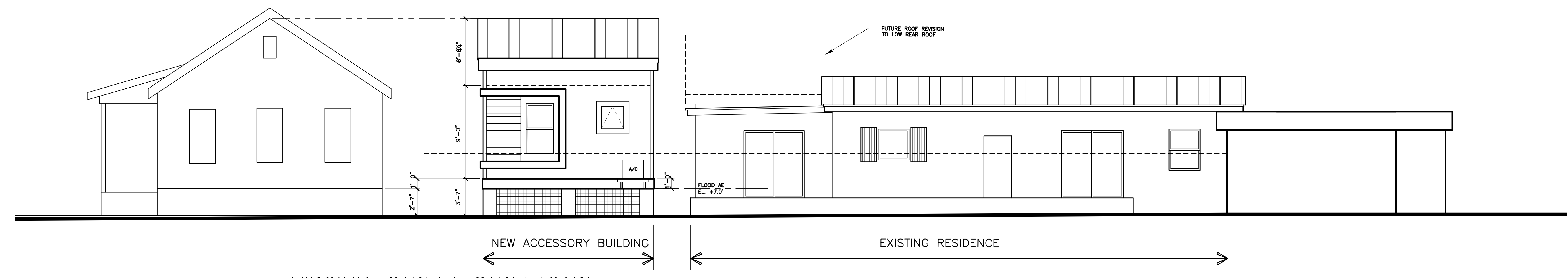

1 VIRGINIA STREET STREETCAPE
A-3 SCALE: 3/16"=1'-0"

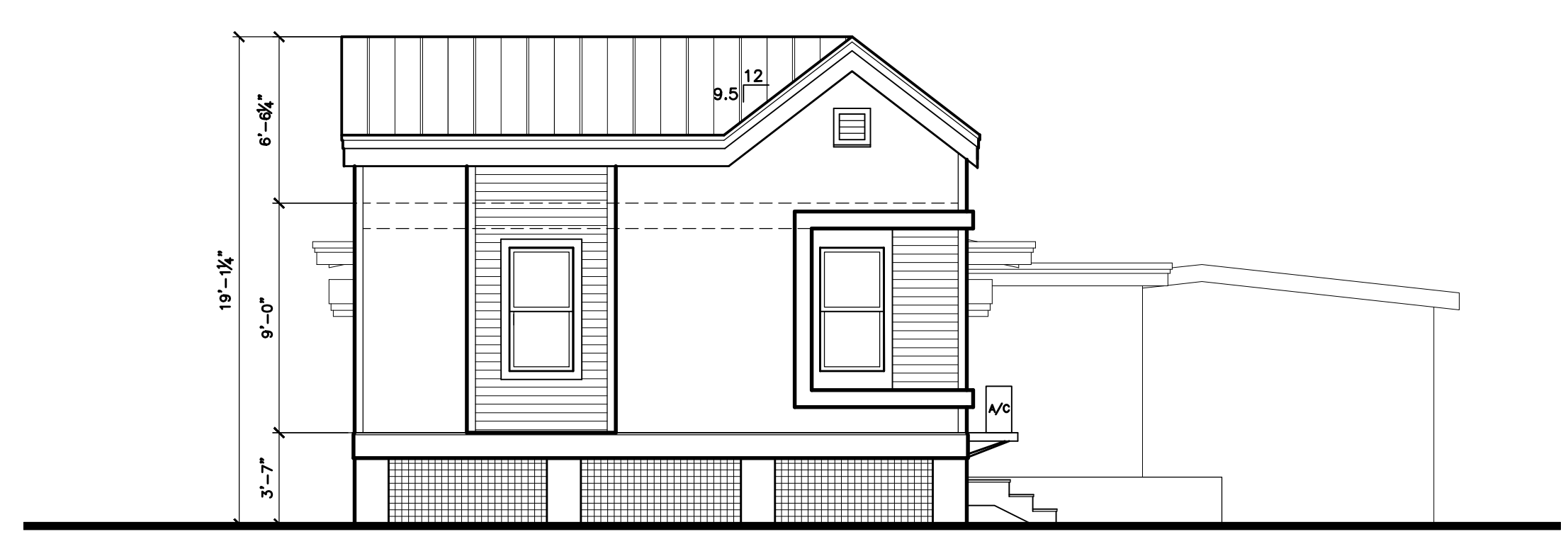

3 REAR ELEVATION
A-3 SCALE: 3/16"=1'-0"

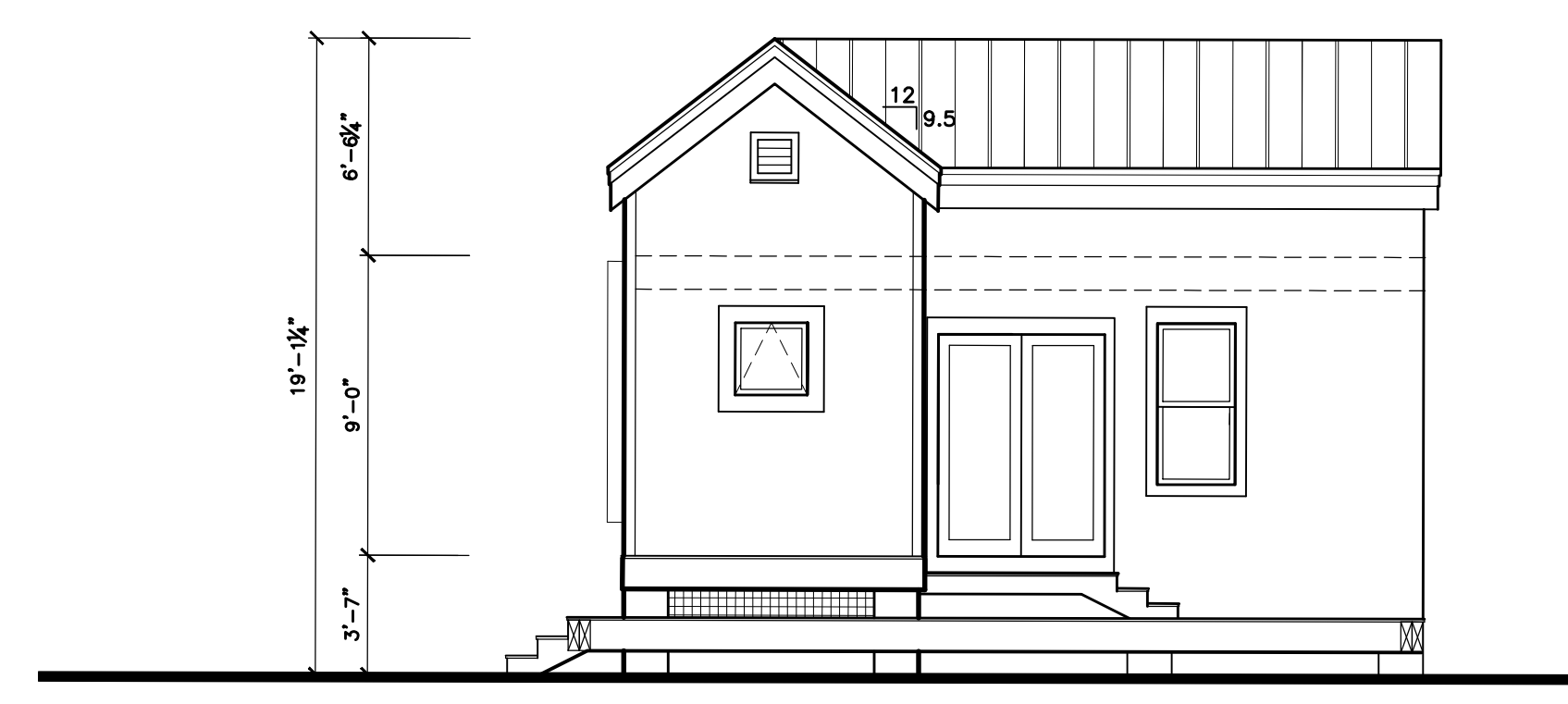

5 INNER ELEVATION
A-3 SCALE: 3/16"=1'-0"

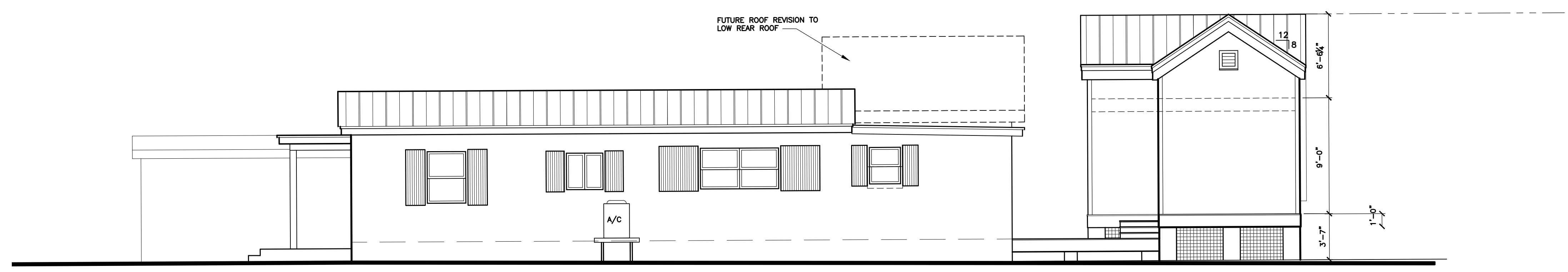

4 SIDE ELEVATION
A-3 SCALE: 3/16"=1'-0"

SEAL

DATE
07-13-15
10-01-15 HARC

REVISIONS

DRAWN BY
JW
EMA
PROJECT NUMBER
1517

PUENTE-TREPANIER RESIDENCE

1024 & 1026 THOMAS STREET
KEY WEST, FLORIDA

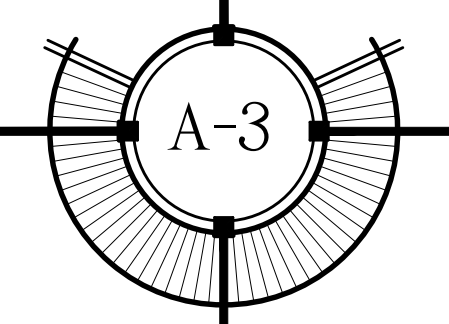

NOTICING

Public Meeting Notice

The Historic Architectural Review Commission will hold a public hearing at 5:30 p.m., December 15, 2015 at Old City Hall, 510 Greene Street, Key West, Florida. The purpose of the hearing will be to consider a request for:

NEW ONE AND A HALF STORY FRAME ACCESSORY STRUCTURE AT REAR OF PROPERTY. DEMOLITION OF EXISTING CARPORT.

FOR- #1024-1026 THOMAS STREET

Applicant – William P. Horn

Application #H15-01-1677

If you wish to see the application or have any questions, you may visit the Planning Department during regular office hours at 3140 Flagler Avenue, call 305-809-3975 or visit our website at www.cityofkeywest-fl.gov.

THIS NOTICE CAN NOT BE REMOVED FROM THE SITE UNTIL HARC FINAL DETERMINATION

ADA ASSISTANCE: It is the policy of the City of Key West to comply with all requirements of the Americans with Disabilities Act (ADA). Please call the TTY number at 800-955-8771 or 800-955-8770 (Voice) or the ADA Coordinator at 305-809-3731 at least five business days in advance for sign language interpreters, assistive listening devices, or materials in accessible format.



1024

Public Meeting Notice

HARC POSTING AFFIDAVIT

STATE OF FLORIDA:
COUNTY OF MONROE:

BEFORE ME, the undersigned authority, personally appeared JOANNA WALCZAK, who, first being duly sworn, on oath, depose and says that the following statements are true and correct to the best of his/her knowledge and belief:

1. That a legal notice for Public Notice of Hearing of the Historic Architectural Review Commission (HARC) was placed on the following address: 1024-1026 THOMAS STREET on the 8 day of DECEMBER, 2015.

This legal notice(s) contained an area of at least 8.5"x11".

The property was posted to notice a public hearing before the Key West Historic Architectural Review Commission to be held on DECEMBER 15, 2015.

The legal notice(s) is/are clearly visible from the public street adjacent to the property.

The Certificate of Appropriateness number for this legal notice is H15-01-1677

2. A photograph of that legal notice posted in the property is attached hereto.

Signed Name of Affiant:

Joanna Walczak
Date: 12/10/15
Address: 915 EATON ST.
City: KEY WEST
State, Zip: FL, 33040

The forgoing instrument was acknowledged before me on this 10th day of December, 2015.

By (Print name of Affiant) Joanna Walczak who is ~~personally known to me or~~ has produced Drivers License as identification and who did take an oath.

NOTARY PUBLIC

Sign Name: Jo Bennett
Print Name: Jo Bennett
Notary Public - State of Florida (seal)
Mv Commission Expires:

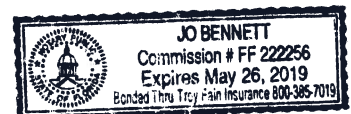

PROPERTY APPRAISER INFORMATION

- [» Tax Collector](#)

Monroe County Cities

- [» City of Key West](#)
- [» City of Marathon](#)
- [» City of Key Colony Beach](#)
- [» City of Layton](#)
- [» Islamorada, Village of Islands](#)

First Time Home Buyer (IRS)

- [» Cancellation of Debt Flyer \(English\)](#)
- [» Cancellation of Debt Flyer \(Spanish\)](#)
- [» 1st Time Homebuyers Fact Sheet](#)
- [» 1st Time Homebuyers Basic Information](#)
- [» 1st Time Homebuyers Scenarios](#)
- [» 1st Time Homebuyers Q& A's](#)

IRS Links

- [» Make Work Pay Credit](#)
- [» Energy Conservation Credit](#)

Other Links

- [» FL Dept Rev - Property Tax Oversight](#)
- [» Census Info](#)

Property Record Card -

Maps are now launching the new map application version.

[Return to Search Results](#) | [Modify Search](#) | [New Search](#) | [Send Email to MCPA Regarding this Parcel](#) | [Estimate Taxes on this Parcel](#)

Previous Record **Alternate Key: 1027545 Parcel ID: 00026750-000000** Next Record

Ownership Details

Mailing Address:

TREPANIER OWEN JOHN
1024-1026 THOMAS ST
KEY WEST, FL 33040

All Owners:

PUENTE RICHARD R/S, TREPANIER OWEN JOHN

Property Details

PC Code: 12 - STORE/OFF/RES OR COMBINATION
 Millage Group: 11KW
 Affordable Housing: No
 Section-Township-Range: 06-68-25
 Property Location: 1026 THOMAS ST KEY WEST
 1024 THOMAS ST KEY WEST
 Subdivision: Tracts 10 and 15
 Legal Description: KW PB1-25-40 PT LOTS 7 & 8 SQR 6 TR 10 XX-59 OR237-562/563 OR505-661/662 OR1372-592D/C OR2071-350/352P/R

[Click Map Image to open interactive viewer](#)

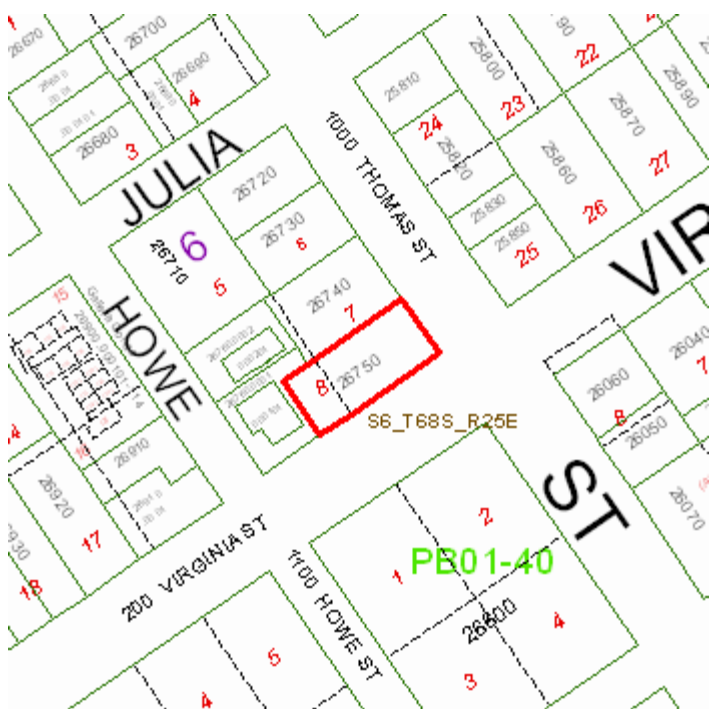

Exemptions

Exemption	Amount
44 - ADDL HOMESTEAD	25,000.00
38 - HOMESTEAD R/S	25,000.00

Land Details

Land Use Code	Frontage	Depth	Land Area
100D - COMMERCIAL DRY	40	88	3,463.25 SF

Building Summary

Number of Buildings: 1

Number of Commercial Buildings: 1

Total Living Area: 1604

Year Built: 1969

Building 1 Details

Building Type		Condition	A	Quality Grade	450
Effective Age	20	Perimeter	226	Depreciation %	23
Year Built	1969	Special Arch	0	Grnd Floor Area	1,604
Functional Obs	0	Economic Obs	0		

Inclusions:

Roof Type		Roof Cover		Foundation	
Heat 1		Heat 2		Bedrooms	0
Heat Src 1		Heat Src 2			

Extra Features:

2 Fix Bath	0	Vacuum		0
3 Fix Bath	0	Garbage Disposal		0
4 Fix Bath	0	Compactor		0
5 Fix Bath	0	Security		0
6 Fix Bath	0	Intercom		0
7 Fix Bath	0	Fireplaces		0
Extra Fix	7	Dishwasher		0

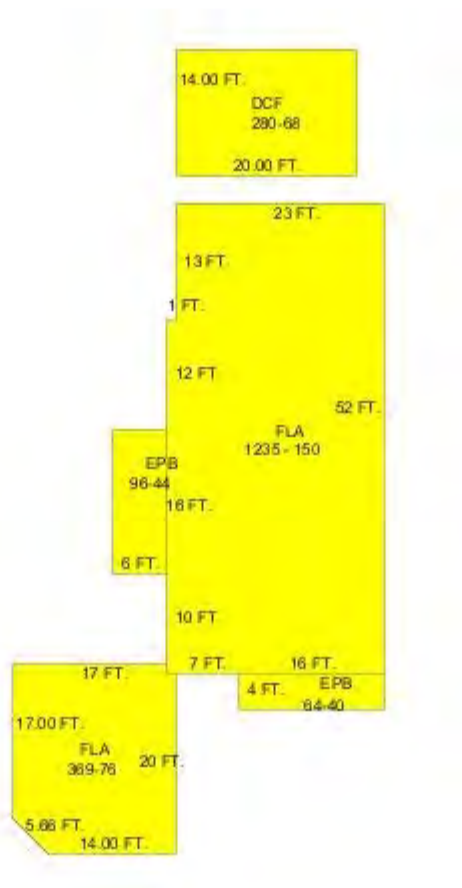

Sections:

Nbr	Type	Ext Wall	# Stories	Year Built	Attic	A/C	Basement %	Finished Basement %	Area
1	FLA		1	1969					1,235
2	EPB		1	1994					64
3	FLA		1	1969					369
4	EPB		1	1994					96
5	DCF		1	1975					280

Interior Finish:

Section Nbr	Interior Finish Nbr	Type	Area %	Sprinkler	A/C
	3732	APARTMENTS	100	N	N
	3734	1 STORY STORES	100	N	N

Exterior Wall:

Interior Finish Nbr	Type	Area %
989	C.B.S.	100

Misc Improvement Details

Nbr	Type	# Units	Length	Width	Year Built	Roll Year	Grade	Life
1	FN2:FENCES	360 SF	0	0	1975	1976	2	30

2	PT3:PATIO	45 SF	15	3	1968	1969	2	50
3	CL2:CH LINK FENCE	20 SF	5	4	1968	1969	1	30
4	FN2:FENCES	240 SF	40	6	2005	2006	2	30
5	FN2:FENCES	240 SF	40	6	2000	2001	2	30
6	AC2:WALL AIR COND	1 UT	0	0	1984	1985	1	20

Appraiser Notes

OWEN TREPANIER & ASSC.

Building Permits

Bldg Number	Date Issued	Date Completed	Amount	Description	Notes
9700582	03/01/1997	08/01/1997	2,600	Commercial	ROOF
9602937	07/01/1996	08/01/1997	7,000	Commercial	REPAIR/REMODELING
9701285	04/01/1997	08/01/1997	3,500	Commercial	ELECTRICAL
9901357	04/26/1999	11/24/1999	1,500	Commercial	CLEAN & PAINT THE EXTERIO
9904090	12/17/1999	08/10/2000	1,800	Commercial	ROOFING
05-0836	03/16/2005	12/13/2005	400	Commercial	ELECTRICAL
05-2080	05/29/2005	12/13/2005	1,400	Commercial	INSTALL SECURITY LIGHTS AROUND THE HOUSE
05-2090	06/01/2005	12/13/2005	250	Commercial	INSTALL 35'x6' PICKET FGENCE
06-5606	10/10/2006	12/19/2006	100	Commercial	REPAIR FENCE.

Parcel Value History

Certified Roll Values.

[View Taxes for this Parcel.](#)

Roll Year	Total Bldg Value	Total Misc Improvement Value	Total Land Value	Total Just (Market) Value	Total Assessed Value	School Exempt Value	School Taxable Value
2015	195,616	2,040	396,883	594,539	520,489	25,000	495,851
2014	195,616	1,914	382,709	580,239	506,029	25,000	489,705
2013	195,616	1,973	292,347	489,936	489,935	25,000	464,936
2012	205,778	2,023	292,347	500,148	500,148	25,000	475,148
2011	205,778	2,082	389,796	597,656	572,342	25,000	547,343
2010	215,940	2,141	339,175	557,256	557,255	25,000	532,256
2009	215,940	2,191	412,829	630,960	580,181	25,000	555,182
2008	215,940	2,250	432,906	651,096	583,963	25,000	558,963
2007	149,048	2,307	398,274	549,629	549,629	25,000	524,629
2006	139,393	1,853	294,376	560,000	560,000	25,000	535,000
2005	137,137	3,206	242,428	560,000	560,000	0	560,000
2004	111,158	3,294	207,795	322,247	322,247	0	322,247
2003	111,158	3,381	103,898	218,437	218,437	0	218,437
2002	111,158	3,478	55,412	170,048	138,549	25,500	113,049

2001	111,158	3,566	55,412	170,136	137,003	25,500	111,503
2000	111,158	1,298	48,486	160,942	131,222	25,500	105,722
1999	111,158	1,334	35,742	148,234	113,414	25,500	87,914
1998	74,278	1,372	35,742	111,392	103,691	25,500	78,191
1997	71,384	1,228	30,636	103,248	100,513	25,500	75,013
1996	64,895	1,263	30,636	96,794	96,794	25,500	71,294
1995	64,895	1,299	30,636	96,830	96,830	25,000	71,830
1994	64,895	1,335	30,636	96,866	96,866	25,000	71,866
1993	64,895	1,184	30,636	96,715	96,715	25,000	71,715
1992	64,895	1,220	30,636	96,751	96,751	25,000	71,751
1991	64,895	1,256	30,636	96,787	96,787	25,000	71,787
1990	51,108	1,420	22,339	74,867	74,867	25,000	49,867
1989	51,108	1,420	21,701	74,229	74,229	25,000	49,229
1988	45,272	1,420	17,871	64,563	64,563	25,000	39,563
1987	44,561	1,420	9,127	55,108	55,108	25,000	30,108
1986	44,766	1,420	8,425	54,611	54,611	25,000	29,611
1985	43,048	1,420	8,450	52,918	52,918	25,000	27,918
1984	41,094	1,420	8,450	50,964	50,964	25,000	25,964
1983	41,130	1,420	8,450	51,000	51,000	25,000	26,000
1982	24,123	1,420	6,266	31,809	31,809	25,000	6,809

Parcel Sales History

NOTE: Sales do not generally show up in our computer system until about two to three months after the date of sale. If a recent sale does not show up in this list, please allow more time for the sale record to be processed. Thank you for your patience and understanding.

Sale Date	Official Records Book/Page	Price	Instrument	Qualification
12/21/2004	2071 / 350	655,000	WD	Q

This page has been visited 131,590 times.

Monroe County Property Appraiser
 Scott P. Russell, CFA
 P.O. Box 1176 Key West, FL 33041-1176