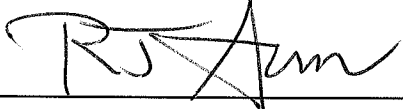

NOTE TO BIDDER: Use BLACK ink for completing this Bid form.

BID

To: The City of Key West
Address: 525 Angela Street, Key West, Florida 33040
Project Title: General Services Contract 2010
Project: ITB #10-015

BIDDER'S INFORMATION

Name: CHARLEY TOPPINO & SONS, INC.
Address: P.O. Box 787
Key West, FL 33041
Contact Name: Ronald J. Armstrong
Email: TOPPKW @ AOL.com
Telephone: 305 296 5606
Fax: 305 296 5199
Signature:  **Date:** 9/27/10

BIDDER'S DECLARATION AND UNDERSTANDING

The undersigned, hereinafter called the Bidder, declares that the only persons or parties interested in this Bid are those named herein, that this Bid is, in all respects, fair and without fraud, that it is made without collusion with any official of the Owner, and that the Bid is made without any connection or collusion with any person submitting another Bid on this Contract.

The Bidder further declares that for each Work Order he/she will carefully examine the Work Order Documents for the construction of the project, that he/she will personally inspected the site, that he/she will satisfied himself/herself as to the quantities involved, including materials and equipment, and conditions of work involved.

The Bidder further agrees that he/she will exercise his/her own judgment regarding the interpretation of job conditions for a Work Order and has utilized all data, which he/she believes pertinent from the Project Manager, Owner, and other sources in arriving at his/her conclusions.

The intent of the Work Order is to describe a functionally complete project (or part thereof) to be constructed in accordance with the Contract Documents. Any work, materials, or equipment that may reasonably be inferred from the Work Order, as being required to produce the intended result shall be supplied whether or not specifically called for.

The Bidder understands and agrees that the OWNER may elect to award all schedules under one Contract, separately, or in any combination that best serves the interests of the OWNER.

CONTRACT EXECUTION AND BONDS

The Bidder agrees that if a Work Order is issued he/she will, within ten (10) calendar days after issuance, sign the Work Order in the form annexed hereto, will attach all required licenses and certificates, and will, to the extent of his BID, furnish all equipment, materials, and labor necessary to complete all work as specified or indicated in the Contract Documents. Performance and Payment Bonds in an amount equal to 100% of Work Order value will be required as part of this contract.

CERTIFICATES OF INSURANCE

Bidder agrees to furnish the Owner, before commencing the work under this Contract, the certificates of insurance as specified in these Documents.

START OF CONSTRUCTION AND CONTRACT COMPLETION TIME

The Bidder further agrees to complete the construction of all items in the Work Order, in all respects, within the specified time of the Work Order

LIQUIDATED DAMAGES

In the event the Bidder is issued a Work Order and shall fail to complete the work within the time limit or extended time limit agreed upon as more particularly set forth in the Contract Documents, liquidated damages shall be paid to the Owner at the rate of five hundred dollars (\$500.00) per day for the work awarded under this Work Order until the work has been satisfactorily completed as provided by the Contract Documents. Sundays and legal holidays shall be included in determining days in default.

ADDENDA

The Bidder hereby acknowledges that he has received Addenda No's. , , , , , , (Bidder shall insert No. of each Addendum received) and agrees that all addenda issued are hereby made part of the Contract Documents, and the Bidder further agrees that his Bid(s) includes all impacts resulting from said addenda.

SALES AND USE TAXES

The Bidder agrees that all federal, state, and local sales and use taxes are included in the stated Bid prices for the work.

PUBLIC ENTITY CRIMES

“A person or affiliate who has been placed on the convicted vendor list following a conviction for a public entity crime may not submit a Bid on a contract to provide any goods or services to a public entity, may not submit a Bid on a contract with a public entity for the construction or repair of a public building or public work, may not submit Bids on leases of real property to a public entity, may not be awarded or perform work as a contractor, supplier, subcontractor, or consultant under a contract with any public entity and may not transact business with any public entity in excess of the threshold amount provided in Section 287.017, for CATEGORY TWO for a period of 36 months from the date of being placed on the convicted vendor list.”

List items to be performed by CONTRACTOR's own forces
(Use additional sheets if necessary.)

All: except Asphalt	

SUBCONTRACTORS

The Owner reserves the right to prohibit use of a subcontractor do to past substandard performance history with the City.

The Bidder further proposes that the following subcontracting firms or businesses will be awarded subcontracts for the following portions of the work in the event that the Bidder is awarded the Contract (additional subcontractors may be added at a later date):

Portion of Work: Asphalt
Name: Bee Bros
Address: 8362 Pines Blvd Pembroke Pines, FL 33024

Portion of Work: _____

Name: _____

Address: _____

Portion of Work: _____

Name: _____

Address: _____

BIDDER

The name of the Bidder submitting this Bid is: CHARLEY TOPPINO & SONS, INC.

Doing business at P.O. Box 787

City Key West State FL Zip 33041

Telephone No. 305 296 5606

This address is where all communications concerning this Bid shall be sent.

The names of the principal officers of the Corporation submitting this Bid, or of the Partnership, or of all persons interested in this Bid as Principals are as follows:

Name	Title
Frank P. Toppino	President
Edward Toppino, Sr	Secretary Treasurer
Paul E. Toppino	Director

If Corporation

IN WITNESS WHEREOF the undersigned corporation has caused this instrument to be executed and its seal affixed by its duly authorized officers this 27 day of Sept, 2010.

(SEAL)

Name of Corporation **CHARLEY TOPPINO & SONS, INC.**

By: Frank P. Toppino

Title: President

Attest: Paul E. Toppino
Secretary

If Sole Proprietor or Partnership

IN WITNESS hereto the undersigned has set his/her/its hand this _____ day of _____, 2010.

Signature of Bidder _____

Title _____

UNIT PRICE BID FORM

The Bidder agrees to accept as full payment for the work issued in a Work Order herein the amounts computed under the provisions of the Contract Documents, the City's Standard Contract Conditions, and based on the following unit price amounts. The Bidder agrees that the unit prices represent a true measure of the labor and materials required to perform the work meeting or exceeding the City of Key West's standard specifications, including all allowances for overhead/profit/insurance, etc. for each type and unit of work called for in these Contract Documents. Should there be any questions concerning the required standard, Bidder shall request clarification from the Engineer. The amounts shall be shown in both words and figures. In case of a discrepancy, the amount shown in words shall govern.

Payment for materials and equipment authorized by the ENGINEER in a written Work Order but not listed in the Bid Form will be provided at the suppliers invoice plus 20%.

BID FORM

#	ITEM	Unit	Per Unit \$	Per Unit Word
1	Performance and Payment Bonds			
a	For First \$100,000 Worth Of Construction Per/\$1,000 of Construction	ea	14.40	FOURTEEN DOLLARS & 40/100
b	For First \$400,000 Worth Of Construction Per/\$1,000 of Construction	ea	14.40	FOURTEEN DOLLARS & 40/100
c	For First \$2,000,000 Worth Of Construction Per/\$1,000 of Construction	ea	9.60	NINE DOLLARS & 60/100
d	For First \$2,500,000 Worth Of Construction Per/\$1,000 of Construction	ea	7.80	SEVEN DOLLARS & 80/100
e	For First \$2,500,000 Worth Of Construction Per/\$1,000 of Construction	ea	7.20	SEVEN DOLLARS & 20/100
2	Job/Demob			
a	Mobilization & Demobilization, % of Work Order (includes M.O.T., General & Supplementary Conditions, Certified AutoCAD As-builts)	%	5.00	Five
b	Project signs	EA	700.00	SEVEN HUNDRED DOLLARS & 00/100
3	Personnel			
a	Superintendent	hr	80.73	EIGHTY DOLLARS & 73/100
b	Foreman	hr	60.55	SIXTY DOLLARS & 55/100
c	Operator	hr	38.75	THIRTY EIGHT DOLLARS & 75/100
d	Laborer	hr	27.90	TWENTY SEVEN DOLLARS & 90/100
e	Mason	hr	46.50	FORTY SIX DOLLARS & 50/100
f	Licensed Surveyor	hr	77.50	SEVENTY SEVEN DOLLARS & 50/100
4	Equipment			
a	Backhoe, with Rock Bucket, without Operator, Cat 426, or Equal	day	765.00	SEVEN HUNDRED SIXTY FIVE DOLLARS & 00/100
b	Backhoe, with Rock Bucket, without Operator, Cat 320, or Equal	day	810.00	EIGHT HUNDRED TEN DOLLARS & 00/100
c	Wheel Front End Loader, without Operator, Cat 950, or Equal	day	810.00	EIGHT HUNDRED TEN DOLLARS & 00/100
d	Air compressor, 165 C.F.M.	day	225.00	TWO HUNDRED TWENTY FIVE DOLLARS & 00/100
e	Dump Truck, 15 CY without Operator	day	630.00	SIX HUNDRED THIRTY DOLLARS & 00/100
f	Flatbed Dump Truck, without Operator	day	450.00	FOUR HUNDRED FIFTY DOLLARS & 00/100
g	Backhoe, Rubber Tire, Various Attachments, without Operator, Ackerman HTMC, or equal	day	1,125.00	ONE THOUSAND, ONE HUNDRED TWENTY FIVE DOLLARS & 00/100
h	Trailer, Scow, off-road sand truck, without Operator, 24CY minimum	day	720.00	SEVEN HUNDRED TWENTY DOLLARS & 00/100
i	Pavement Saw	day	180.00	ONE HUNDRED EIGHTY DOLLARS & 00/100
j	3-inch Trash Pump	day	180.00	ONE HUNDRED EIGHTY DOLLARS & 00/100
k	4-inch Trash Pump	day	270.00	TWO HUNDRED SEVENTY DOLLARS & 00/100

l	6-inch Hydraulic Pump	day	\$ 720.00	SEVEN HUNDRED TWENTY DOLLARS & 00/100
m	1000 Gallon Sediment Box	day	\$ 180.00	ONE HUNDRED EIGHTY DOLLARS & 00/100
n	Jet Truck (Cleaning)	day	\$ 1,350.00	ONE THOUSAND, THREE HUNDRED FIFTY DOLLARS & 00/100
o	Laser	day	\$ 45.00	FORTY FIVE DOLLARS & 00/100
p	Vibratory Roller	day	\$ 495.00	FOUR HUNDRED NINETY FIVE DOLLARS & 00/100
q	Plate Compactor	day	\$ 90.00	NINETY DOLLARS & 00/100
r	Dozer	day	\$ 765.00	SEVEN HUNDRED SIXTY FIVE DOLLARS & 00/100
s	Road Grader	day	\$ 900.00	NINE HUNDRED DOLLARS & 00/100
t	Bob Cat or Equivalent	day	\$ 405.00	FOUR HUNDRED FIVE DOLLARS & 00/100
u	Water Truck	day	\$ 450.00	FOUR HUNDRED FIFTY DOLLARS & 00/100
v	Huber Grader	day	\$ 675.00	SIX HUNDRED SEVENTY FIVE DOLLARS & 00/100
w	18" Auger Truck	day	\$ 3,600.00	THREE THOUSAND SIX HUNDRED DOLLARS & 00/100
5	Materials			
a	Crushed Rock	ton	\$ 35.00	THIRTY FIVE DOLLARS & 00/100
b	No. 57 Rock	ton	\$ 35.00	THIRTY FIVE DOLLARS & 00/100
c	No. 89 Rock	ton	\$ 40.00	FORTY DOLLARS & 00/100
d	Screening Sand	ton	\$ 35.00	THIRTY FIVE DOLLARS & 00/100
e	Ortona Sand (0.35 - 0.65 grain size)	ton	\$ 65.00	SIXTY FIVE DOLLARS & 00/100
f	Coral Sand	ton	\$ 35.00	THIRTY FIVE DOLLARS & 00/100
g	No. 4 Rock	ton	\$ 35.00	THIRTY FIVE DOLLARS & 00/100
h	Sod	sf	\$ 0.50	FIFTY CENTS
	Trench Excavation & Backfill Per Detail 3123-110			
6	Pipe 12 inches and Under			
a	0-6 feet Deep	If	\$ 70.77	SEVENTY DOLLARS & 77/100
b	6-8 feet Deep	If	\$ 92.56	NINETY TWO DOLLARS & 56/100
c	8-10 feet Deep	If	\$ 115.79	ONE HUNDRED FIFTEEN DOLLARS & 79/100
d	10-12 feet Deep	If	\$ 149.54	ONE HUNDRED FORTY NINE DOLLARS & 54/100
7	Pipe 15 inches through 24 inches			
a	0-6 feet Deep	If	\$ 78.77	SEVENTY EIGHT DOLLARS & 77/100
b	6-8 feet Deep	If	\$ 81.06	EIGHTY ONE DOLLARS & 06/100
c	8-10 feet Deep	If	\$ 119.47	ONE HUNDRED NINETEEN DOLLARS & 47/100
d	10-12 feet Deep	If	\$ 146.72	ONE HUNDRED FORTY SIX DOLLARS & 72/100

8	Pipe 30 inches through 36 inches						ONE HUNDRED THIRTY DOLLARS & 22/100
a	0-6 feet Deep	If	\$	130.22			ONE HUNDRED THIRTY DOLLARS & 22/100
b	6-8 feet Deep	If	\$	148.53			ONE HUNDRED FORTY EIGHT DOLLARS & 53/100
c	8-10 feet Deep	If	\$	207.79			TWO HUNDRED SEVEN DOLLARS & 79/100
d	10-12 feet Deep	If	\$	372.10			THREE HUNDRED SEVENTY TWO DOLLARS & 10/100
9	Pipe 42 inches through 48 inches						
a	0-6 feet Deep	If	\$	156.66			ONE HUNDRED FIFTY SIX DOLLARS & 66/100
b	6-8 feet Deep	If	\$	197.19			ONE HUNDRED NINETY SEVEN DOLLARS & 19/100
c	8-10 feet Deep	If	\$	262.93			TWO HUNDRED SIXTY TWO DOLLARS & 93/100
d	10-12 feet Deep	If	\$	379.25			THREE HUNDRED SEVENTY NINE DOLLARS & 25/100
10	Pipe 54 inches through 60 inches						
a	0-6 feet Deep	If	\$	173.25			ONE HUNDRED SEVENTY THREE DOLLARS & 25/100
b	6-8 feet Deep	If	\$	215.71			TWO HUNDRED FIFTEEN DOLLARS & 71/100
c	8-10 feet Deep	If	\$	287.61			TWO HUNDRED EIGHTY SEVEN DOLLARS & 61/100
d	10-12 feet Deep	If	\$	429.33			FOUR HUNDRED TWENTY NINE DOLLARS & 33/100
11	During Sewer Service Lateral Installation, Not Part of Sewer Main Installation Pipe 6 inches						
a	0-6 feet Deep	If	\$	50.00			FIFTY DOLLARS & 00/100
b	6-8 feet Deep	If	\$	75.00			SEVENTY FIVE DOLLARS & 00/100
c	8-10 feet Deep	If	\$	100.00			ONE HUNDRED DOLLARS & 00/100
d	10-12 feet Deep	If	\$	120.00			ONE HUNDRED TWENTY DOLLARS & 00/100
12	Foundation Stabilization						
a	Foundation Stabilization	cy	\$	50.00			FIFTY DOLLARS & 00/100
13	Trench Safety Systems (s)						
a	Trench Safety Systems - OSHA Compliance	If	\$	50.00			FIFTY DOLLARS & 00/100

14	Surface Restoration							
		Change to SY						
a	Lime Rock Base	SY	\$	18.00	EIGHTEEN DOLLARS & 00/100			
b	Lime Rock Base over Sewer Trenches, Pipe 12 inches through 24 inches	lf	\$	30.00	THIRTY DOLLARS & 00/100			
c	Lime Rock Base over Sewer Trenches, Pipe 30 inches through 48 inches	lf	\$	45.00	FORTY FIVE DOLLARS & 00/100			
d	Lime Rock Base over Sewer Service Lines	lf	\$	30.00	THIRTY DOLLARS & 00/100			
e	Asphalt Surface Repair	SY						
f	Flowable Fill (500 psi)	CY	\$	180.00	ONE HUNDRED EIGHTY DOLLARS & 00/100			
15	Pavement							
a	Removal of Bituminus Surface	SF	\$	0.50	FIFTY CENTS			
b	Raise Manhole Lids	ea	\$	250.00	TWO HUNDRED FIFTY DOLLARS & 00/100			
c	Raise Water Valve	ea	\$	300.00	THREE HUNDRED DOLLARS & 00/100			
d	Raise Stormwater Inlet Grates	ea	\$	250.00	TWO HUNDRED FIFTY DOLLARS & 00/100			
e	Asphalt Concrete Overlay	ton	\$	516.00	FIVE HUNDRED SIXTEEN DOLLARS & 00/100			
f	Rework Existing Base	SY	\$	4.80	FOUR DOLLARS & 80/100			
g	Asphalt Concrete Leveling Course	ton	\$	507.60	FIVE HUNDRED SEVEN DOLLARS & 60/100			
h	Asphalt Milling (angle milling machine) for amall patchwork (less than 400SF patches)	SY	\$	110.40	ONE HUNDRED TEN DOLLARS & 40/100			
i	Asphalt Milling (road or curbside or large sections)	SY	\$	49.20	FORTY NINE DOLLARS & 20/100			
j	Asphalt Imprinting / Asphalt Coloring	SY	\$	100.00	ONE HUNDRED DOLLARS & 00/100			
k	Saw Cut Asphalt 0" - 6"	lf	\$	1.00	ONE DOLLAR & 00/100			
l	Saw Cut Asphalt > 6"	lf	\$	2.00	TWO DOLLARS & 00/100			
m	Saw Cut Concrete 0" - 6"	lf	\$	2.00	TWO DOLLARS & 00/100			
n	Saw Cut Concrete > 6"	lf	\$	5.00	FIVE DOLLARS & 00/100			
16	Sidewalk Installation							
a	4 inches depth	SF	\$	7.50	SEVEN DOLLARS & 50/100			
b	6 inches depth	SF	\$	8.90	EIGHT DOLLARS & 90/100			
c	Rebar # 4	lb	\$	1.50	ONE DOLLAR & 50/100			
d	Concrete sidewalk and curb repairs	CY	\$	400.00	FOUR HUNDRED DOLLARS & 00/100			
e	Thickened Edge	lf	\$	6.00	SIX DOLLARS & 00/100			
17	Curb Installation							
92	FDOT Type D	lf	\$	21.00	TWENTY ONE DOLLARS & 00/100			
93	FDOT Type F	lf	\$	25.00	TWENTY FIVE DOLLARS & 00/100			
94	FDOT Drop Curb	lf	\$	22.00	TWENTY TWO DOLLARS & 00/100			

18	Formed Concrete, placed						SIX HUNDRED FIFTY DOLLARS & 00/100
a	Misc. Formed Concrete, places (i.e.: small retaining walls, etc.)	cy	\$	650.00			00/100
b	Concrete Band (12" X 18" with steel)	cy	\$	600.00			SIX HUNDRED DOLLARS & 00/100
19	Pigmentation of concrete (Lambert Southwest Dry Cement Colors, integral, or equal						
a	All Colors	sf	\$	10.00			TEN DOLLARS & 00/100
20	Stamped Concrete						
a	Stamping Concrete	sf	\$	10.00			TEN DOLLARS & 00/100
99	Sealer - Lambert Colorseal (one coat), or equal	sf	\$	3.00			THREE DOLLARS & 00/100
21	Detectable Warning Paver						
a	2-1/4 X 3-5/8 X 7-5/8 Brick Pavers with ADAAG Detectable Warning System -	sf	\$	25.00			TWENTY FIVE DOLLARS & 00/100
b	2-1/4 X 4 X 8 Brick Pavers with ADAAG Detectable Warning System -	sf	\$	27.00			TWENTY SEVEN DOLLARS & 00/100
22	Pavement Markings						
a	Crosswalk	lf	\$	10.00			TEN DOLLARS & 00/100
b	STOP	ea	\$	100.00			ONE HUNDRED DOLLARS & 00/100
c	Arrow	ea	\$	100.00			ONE HUNDRED DOLLARS & 00/100
d	Seperation Of Lanes	lf	\$	2.00			TWO DOLLARS & 00/100
e	White line	lf	\$	1.20			ONE DOLLAR & 20/100
23	Brick						
a	Brick Installed (ASTM Specification Heavy Vehicular Paving Brick Type II)	sf	\$	15.00			FIFTEEN DOLLARS & 00/100
b	Brick Installed (ASTM Specification Pedestrian Paving Brick Type I)	sf	\$	10.00			TEN DOLLARS & 00/100
24	Stormwater Gravity Injection Well Construction						
	Baffle Box with Injection Well						
a	Install 100' Gravity Injection Well with Triple Chamber Baffle Box, with One Inlet Grate & Two Manhole Lids with a minimum of 60' of 24" PVC Schedule 80	ea	\$	69,000.00			SIXTY NINE THOUSAND DOLLARS & 00/100
b	Install 100' Gravity Injection Well with Triple Chamber Baffle Box, with Three Manhole Lids with a minimum of 60' of 24" PVC Schedule 80 grouted casing	ea	\$	68,000.00			SIXTY EIGHT THOUSAND DOLLARS & 00/100
25	Catch Basin and Inlets						
	Curb Inlets						
a	Type 1 Top, Type P Bottom with 4 ft Diameter Alternate A, 0 6-foot depth	ea	\$	3,411.20			THREE THOUSAND FOUR HUNDRED ELEVEN DOLLARS & 20/100
b	Type 2 Top, Type P Bottom with 4 ft Diameter Alternate A, 0 6-foot depth	ea	\$	4,066.40			FOUR THOUSAND SIXTY SIX DOLLARS & 40/100
c	Type 9 Top, Type P Bottom with 4 ft Diameter Alternate A, 0 6-foot depth	ea	\$	1,467.70			ONE THOUSAND FOUR HUNDRED SIXTY SEVEN DOLLARS & 70/100
d	Type F-3 Top, Type P Bottom with 4 ft Diameter Alternate A, 0 6-foot depth	ea	\$	2,600.00			TWO THOUSAND SIX HUNDRED DOLLARS & 00/100
e	Additional Depth over 6 foot for Type 1, Type 2 or Type 9 Curb Inlet, Type P Bottom with 4 foot Diameter Alternate A	vf	\$	260.00			TWO HUNDRED SIXTY DOLLARS & 00/100

26	Ditch Bottom Inlet			\$	-	NINE HUNDRED FOUR DOLLARS & 80/100
a	Type C, 0 6 foot	ea	\$	904.80	TWO HUNDRED SIXTY DOLLARS & 00/100	
b	Additional Depth over 6 foot Depth for Ditch Bottom Inlet, Type C	vf	\$	260.00	ONE THOUSAND SEVEN HUNDRED SIXTY ONE DOLLARS & 50/100	
c	Type J, 0 6 foot depth	ea	\$	1,761.50	TWO HUNDRED SIXTY DOLLARS & 00/100	
d	Additional Depth over 6 foot Depth for Ditch Bottom Inlet Type J	vf	\$	260.00	ONE THOUSAND THREE HUNDRED DOLLARS & 00/100	
e	Removal of Existing Inlets or Storm Manholes Structures, Unclassified Depth	ea	\$	1,300.00		
27	ADS Polyethylene Pipe		\$	-		
a	12 inches	If	\$	8.71	EIGHT DOLLARS & 71/100	
b	15 inches	If	\$	11.90	ELEVEN DOLLARS & 90/100	
c	18 inches	If	\$	14.77	FOURTEEN DOLLARS & 77/100	
d	24 inches	If	\$	25.82	TWENTY FIVE DOLLARS & 82/100	
e	36 inches	If	\$	47.23	FORTY SEVEN DOLLARS & 23/100	
f	42 inches	If	\$	-		
28	Reinforced Concrete Pipe		\$	-		
a	15 inches	If	\$	12.19	TWELVE DOLLARS & 19/100	
b	18 inches	If	\$	16.97	SIXTEEN DOLLARS & 97/100	
c	24 inches	If	\$	25.84	TWENTY FIVE DOLLARS & 84/100	
29	Reinforced Concrete Pipe Class IV		\$	-		
a	24 inches	If	\$	33.59	THIRTY THREE DOLLARS & 59/100	
b	30 inches	If	\$	48.37	FORTY EIGHT DOLLARS & 37/100	
c	36 inches	If	\$	67.42	SIXTY SEVEN DOLLARS & 42/100	
d	48 inches	If	\$	102.60	ONE HUNDRED TWO DOLLARS & 60/100	
30	PVC Sch 40		\$	-		
a	1/2 inch	If	\$	0.44	FORTY FOUR CENTS	
b	3/4 inch	If	\$	0.74	SEVENTY FOUR CENTS	
c	1 inch	If	\$	1.25	ONE DOLLAR & 25/100	
d	2 inch	If	\$	1.01	ONE DOLLAR & 01/100	
e	4 inch	If	\$	2.43	TWO DOLLARS & 43/100	
f	6 inch	If	\$	7.96	SEVEN DOLLARS & 96/100	
31	PVC Sch 80		\$	13.44	THIRTEEN DOLLARS & 44/100	

a	1/2 inch	If	\$	0.96	NINETY SIX CENTS
b	3/4 inch	If	\$	1.00	ONE DOLLAR & 00/100
c	1 inch	If	\$	1.13	ONE DOLLAR & 13/100
d	2 inch	If	\$	2.11	TWO DOLLARS & 11/100
e	4 inch	If	\$	6.20	SIX DOLLARS & 20/100
f	6 inch	If	\$	14.04	FOURTEEN DOLLARS & 04/100
32	C-900 Pipe DR18		\$	-	
a	4 inch	If	\$	3.64	THREE DOLLARS & 64/100
b	6 inch	If	\$	7.28	SEVEN DOLLARS & 28/100
c	8 inch	If	\$	12.61	TWELVE DOLLARS & 61/100
d	10 inch	If	\$	18.88	EIGHTEEN DOLLARS & 88/100
e	12 inch	If	\$	26.65	TWENTY SIX DOLLARS & 65/100
33	C-900 Pipe DR25		\$	-	
a	4 inch	If	\$	2.60	TWO DOLLARS & 60/100
b	6 inch	If	\$	5.33	FIVE DOLLARS & 33/100
c	8 inch	If	\$	8.91	EIGHT DOLLARS & 91/100
d	10 inch	If	\$	13.72	THIRTEEN DOLLARS & 72/100
e	12 inch	If	\$	19.37	NINETEEN DOLLARS & 37/100
34	C 905 Pipe DR 25		\$	-	
a	14 inch	If	\$	24.70	TWENTY FOUR DOLLARS & 70/100
b	16 inch	If	\$	31.81	THIRTY ONE DOLLARS & 81/100
c	18 inch	If	\$	40.11	FORTY DOLLARS & 11/100
d	20 inch	If	\$	49.10	FORTY NINE DOLLARS & 10/100
e	24 inch	If	\$	70.51	SEVENTY DOLLARS & 51/100
f	30 inch	If	\$	117.40	ONE HUNDRED SEVENTEEN DOLLARS & 40/100
g	36 inch	If	\$	180.91	ONE HUNDRED EIGHTY DOLLARS & 91/100
h	42 inch	If	\$	330.81	THREE HUNDRED THIRTY DOLLARS & 81/100
i	48 inch	If	\$	431.21	FOUR HUNDRED THIRTY ONE DOLLARS & 21/100
35	C 905 Pipe DR41		\$	-	
a	14 inch	If	\$	19.01	NINETEEN DOLLARS & 01/100

b	16 inch	If	\$	20.01	TWENTY DOLLARS & 01/100
c	18 inch	If	\$	30.00	THIRTY DOLLARS & 00/100
d	20 inch	If	\$	30.51	THIRTY DOLLARS & 51/100
e	24 inch	If	\$	44.51	FORTY FOUR DOLLARS & 51/100
f	30 inch	If	\$	72.67	SEVENTY TWO DOLLARS & 67/100
g	36 inch	If	\$	112.50	ONE HUNDRED TWELVE DOLLARS & 50/100
h	42 inch	If	\$	206.80	TWO HUNDRED SIX DOLLARS & 80/100
i	48 inch	If	\$	269.62	TWO HUNDRED SIXTY NINE DOLLARS & 62/100
36	Joints		\$	-	
a	Mechanically Restrained Joints for PVC Pipe 4"	ea	\$	44.11	FORTY FOUR DOLLARS & 11/100
b	Mechanically Restrained Joints for PVC Pipe 6"	ea	\$	57.94	FIFTY SEVEN DOLLARS & 94/100
c	Mechanically Restrained Joints for PVC Pipe 8"	ea	\$	95.62	NINETY FIVE DOLLARS & 62/100
d	Mechanically Restrained Joints for PVC Pipe 10"	ea	\$	166.35	ONE HUNDRED SIXTY SIX DOLLARS & 35/100
e	Mechanically Restrained Joints for PVC Pipe 12"	ea	\$	181.99	ONE HUNDRED EIGHTY ONE DOLLARS & 99/100
f	Mechanically Restrained Joints for PVC Pipe 16"	ea	\$	433.43	FOUR HUNDRED THIRTY THREE DOLLARS & 43/100
g	Mechanically Restrained Joints for PVC Pipe 18"	ea	\$	496.86	FOUR HUNDRED NINETY SIX DOLLARS & 86/100
h	Mechanically Restrained Joints for PVC Pipe 20"	ea	\$	735.05	SEVEN HUNDRED THIRTY FIVE DOLLARS & 05/100
i	Mechanically Restrained Joints for PVC Pipe 24"	ea	\$	859.86	EIGHT HUNDRED FIFTY NINE DOLLARS & 86/100
j	Mechanically Restrained Joints for PVC Pipe 30"	ea	\$	1,744.44	ONE THOUSAND SEVEN HUNDRED FORTY FOUR DOLLARS & 44/100
k	Mechanically Restrained Joints for PVC Pipe 36"	ea	\$	2,162.36	TWO THOUSAND ONE HUNDRED SIXTY TWO DOLLARS & 36/100
l	Mechanically Restrained Joints for PVC Pipe 42"	ea	\$	2,522.00	TWO THOUSAND FIVE HUNDRED TWENTY TWO DOLLARS & 00/100
m	Mechanically Restrained Joints for PVC Pipe 48"	ea	\$	3,201.41	THREE THOUSAND TWO HUNDRED ONE DOLLARS & 41/100
37	Other				
a	Removal of Existing Storm Drain Pipe, Unclassified Depth and Diameter	If	\$	25.00	TWENTY FIVE DOLLARS & 00/100
b	Additional Cost for Exfiltration Trench	If	\$	150.00	ONE HUNDRED FIFTY DOLLARS & 00/100
c	Seepage Trench	If	\$	150.00	ONE HUNDRED FIFTY DOLLARS & 00/100
d	French Drain	Lf	\$	150.00	ONE HUNDRED FIFTY DOLLARS & 00/100
38	Manhole and Miscellaneous Concrete Construction				
	Manholes				
a	Standard 4 foot Diameter Manholes, 0 6-foot Depth	ea	\$	3,494.40	THREE THOUSAND FOUR HUNDRED NINETY FOUR DOLLARS & 40/100
b	Standard 4 foot Diameter Manholes, 0 over 6-foot Depth	vf	\$	345.80	THREE HUNDRED FORTY FIVE DOLLARS & 80/100

c	Drop Manhole Assemblies	vf	\$ 156.00	ONE HUNDRED FIFTY SIX DOLLARS & 00/100
d	Additional Cost to provide Watertight Manhole Frame and Cover in Lieu of Standard Frame & Cover	ea	\$ 156.00	ONE HUNDRED FIFTY SIX DOLLARS & 00/100
e	Conflict Manholes (6-foot Diameter), 0-6 foot Depth	ea	\$ 1,982.50	ONE THOUSAND NINE HUNDRED EIGHTY TWO DOLLARS & 50/100
f	Conflict Manholes (6-foot Diameter), Over 6 foot Depth	vf	\$ 156.00	ONE HUNDRED FIFTY SIX DOLLARS & 00/100
39	Service Connection Pipe Stub outs			
a	6 inches	ea	\$ 500.00	FIVE HUNDRED DOLLARS & 00/100
b	Connections to Existing Manholes	ea	\$ 800.00	EIGHT HUNDRED DOLLARS & 00/100
c	Removal of Existing Manholes, Unclassified Depth	ea	\$ 850.00	EIGHT HUNDRED FIFTY DOLLARS & 00/100
d	Adjusting Existing Manholes	ea		
40	Sewer Connection Services			
a	Sewer Service Connection Pipe	ea	\$ 500.00	FIVE HUNDRED DOLLARS & 00/100
b	Cleanouts	ea	\$ 300.00	THREE HUNDRED DOLLARS & 00/100
c	Cleanout Box	ea	\$ 300.00	THREE HUNDRED DOLLARS & 00/100
41	During Sewer Service Lateral Installation, Not Part of Sewer Main Installation			
a	PVC Wye Installation Any Size	ea	\$ 250.00	TWO HUNDRED FIFTY DOLLARS & 00/100
b	Inserta Tee 6"	ea	\$ 500.00	FIVE HUNDRED DOLLARS & 00/100
42	Cleaning and Internal Inspection of Existing Sewers			
a	6-10 Inch Diameter Pipe	lf	\$ 4.80	FOUR DOLLARS & 80/100
b	12-15 Inch Diameter Pipe	lf	\$ 7.20	SEVEN DOLLARS & 20/100
c	18-24 Inch Diameter Pipe	lf	\$ 13.20	THIRTEEN DOLLARS & 20/100
d	36-42 Inch Diameter Pipe	lf	\$ 15.60	FIFTEEN DOLLARS & 60/100
e	Manhole, Any Diameter	lf		
43	PVC Wye Fittings or Connections			
a	6 X 6	ea	\$ 45.86	FORTY FIVE DOLLARS & 86/100
b	8 X 6	ea	\$ 59.59	FIFTY NINE DOLLARS & 59/100
c	10 X 6	ea	\$ 200.60	TWO HUNDRED DOLLARS & 60/100
d	12 X 6	ea	\$ 273.23	TWO HUNDRED SEVENTY THREE DOLLARS & 23/100
e	15 X 6	ea	\$ 461.39	FOUR HUNDRED SIXTY ONE DOLLARS & 39/100
f	Ductile Iron or Cast Iron Fittings, Complete with Cement Mortar Lining & Thrust Bio	lb	\$ 1,676.25	ONE THOUSAND SIX HUNDRED SEVENTY SIX DOLLARS & 25/100

44	Connections to Dissimilar Gravity Pipe			\$	-	
a	8 inches	ea		\$	27.25	TWENTY SEVEN DOLLARS & 25/100
b	10 inches	ea		\$	40.50	FORTY DOLLARS & 50/100
c	12 inches	ea		\$	47.26	FORTY SEVEN DOLLARS & 26/100
d	15 inches	ea		\$	81.06	EIGHTY ONE DOLLARS & 06/100
e	Removal of Existing Sanitary Sewer Lines, Unclassified Depth & Diameter	lf		\$	62.50	SIXTY TWO DOLLARS & 50/100
f	Concrete Encasement with steel	cy		\$	300.00	THREE HUNDRED DOLLARS & 00/100
	Manually Operated Viaves and Check Valves			\$	-	
45	Installation of Plug Valves and Valve Boxes			\$	-	
a	4 inches depth	ea		\$	1,250.00	ONE THOUSAND TWO HUNDRED FIFTY DOLLARS & 00/100
b	6 inches	ea		\$	1,750.00	ONE THOUSAND SEVEN HUNDRED FIFTY DOLLARS & 00/100
c	8 inches	ea		\$	2,187.50	TWO THOUSAND ONE HUNDRED EIGHTY SEVEN DOLLARS & 50/100
d	10 inches	ea		\$	3,500.00	THREE THOUSAND FIVE HUNDRED DOLLARS & 00/100
e	12 inches	ea		\$	4,625.00	FOUR THOUSAND SIX HUNDRED TWENTY FIVE DOLLARS & 00/100
f	18 inches	ea		\$	8,945.00	EIGHT THOUSAND NINE HUNDRED FORTY FIVE DOLLARS & 00/100
46	Environmental Protection			\$	-	
a	Turbidity Screen	lf		\$	12.50	TWELVE DOLLARS & 50/100
b	Silt Barrier	lf		\$	2.50	TWO DOLLARS & 50/100
c	Concrete Encasement with steel	cy		\$	375.00	THREE HUNDRED SEVENTY FIVE DOLLARS & 00/100
d	Dewatering Trench 4 ft deep	LS		\$	625.00	SIX HUNDRED TWENTY FIVE DOLLARS & 00/100
e	Dewatering Trench 6 ft deep	LS		\$	937.50	NINE HUNDRED THIRTY SEVEN DOLLARS & 50/100
f	Dewatering Trench 8 ft deep	LS		\$	1,250.00	ONE THOUSAND TWO HUNDRED FIFTY DOLLARS & 00/100
g	Dewatering Trench 10 ft deep	LS		\$	1,875.00	ONE THOUSAND EIGHT HUNDRED SEVENTY FIVE DOLLARS & 00/100
h	Dewatering Trench 12 ft deep	LS		\$	2,500.00	TWO THOUSAND FIVE HUNDRED DOLLARS & 00/100
i	Dewatering Pit Excavation	LS		\$	2,500.00	TWO THOUSAND FIVE HUNDRED DOLLARS & 00/100
47	Waterline Relocation			\$	-	
a	4 inch			\$	5,400.00	FIVE THOUSAND FOUR HUNDRED DOLLARS & 00/100
b	6 inch			\$	7,200.00	SEVEN THOUSAND TWO HUNDRED DOLLARS & 00/100
c	8 inch			\$	9,600.00	NINE THOUSAND SIX HUNDRED DOLLARS & 00/100
d	10 inch			\$	12,000.00	TWELVE THOUSAND DOLLARS & 00/100

e	12 inch			\$ 15,600.00	FIFTEEN THOUSAND SIX HUNDRED DOLLARS & 00/100
f	14 inch			\$ 18,000.00	EIGHTEEN THOUSAND DOLLARS & 00/100
g	16 inch			\$ 21,600.00	TWENTY ONE THOUSAND SIX HUNDRED DOLLARS & 00/100
h	18 inch			\$ 24,000.00	TWENTY FOUR THOUSAND DOLLARS & 00/100
48	Permitting				
a	Waterline Install - FKAA			\$ 1,500.00	ONE THOUSAND FIVE HUNDRED DOLLARS & 00/100
b	FDEP			\$ 2,000.00	TWO THOUSAND DOLLARS & 00/100
49	Testing				
a	Bacterial Test-waterline	ea		\$ 1,725.00	ONE THOUSAND SEVEN HUNDRED TWENTY FIVE DOLLARS & 00/100
b	Compaction Testing for soil	ea		\$ 287.50	TWO HUNDRED EIGHTY SEVEN DOLLARS & 50/100
c	Gravity Sewerline Pressure Test	ea		\$ 1,380.00	ONE THOUSAND THREE HUNDRED EIGHTY DOLLARS & 00/100
d	Forcemain Sewerline Pressure Test	ea		\$ 1,380.00	ONE THOUSAND THREE HUNDRED EIGHTY DOLLARS & 00/100
e	Infiltration Test for Manholes	ea		\$ 1,380.00	ONE THOUSAND THREE HUNDRED EIGHTY DOLLARS & 00/100
f	Waterline Pressure Test	ea		\$ 1,380.00	ONE THOUSAND THREE HUNDRED EIGHTY DOLLARS & 00/100
50	Landscaping				
a	Transplant Existing Tree (0-10" in diameter) includes all labor, materials, equipment & maintenance	ea		\$ 500.00	FIVE HUNDRED DOLLARS & 00/100
b	Plant New Tree (0-10" diameter) includes all labor, materials, equipment & maintenance	ea		\$ 1,000.00	ONE THOUSAND DOLLARS & 00/100
c	Transplant Existing Tree (over 10" in diameter) includes all labor, materials, equipment & maintenance	ea		\$ 1,000.00	ONE THOUSAND DOLLARS & 00/100
d	Plant New Tree (over 10" diameter) includes all labor, materials, equipment & maintenance	ea		\$ 2,000.00	TWO THOUSAND DOLLARS & 00/100
e	Sod Removal	sf		\$ 0.45	FORTY FIVE CENTS
f	Sod Replacement	sf		\$ 0.50	FIFTY CENTS
g	Seeding	sf		\$ 0.50	FIFTY CENTS
h	Debris Removal and hauling to an acceptable certified landfill	ton		\$ 100.00	ONE HUNDRED DOLLARS & 00/100
i	Tree removal: 8"-10" Diameter Pine	ea		\$ 500.00	FIVE HUNDRED DOLLARS & 00/100
j	Fence: 6' Chain Link w/ 3 strand Barbed wire: remove & reinstall (Changed to LF)	lf		\$ 15.00	FIFTEEN DOLLARS & 00/100

51	Roadway Signs						
a	F.D.O.T. Sign Installation (includes sign, post and installation)	ea	\$	500.00	FIVE HUNDRED DOLLARS & 00/100		
52	Other						
a	Markup Allowed - materials, equipment, testing, etc. not listed above	%		15%	Fifteen		
53	HDPE DR 17						
a	12 inch	If	\$	39.16	THIRTY NINE DOLLARS & 16/100		
b	18 Inch	If	\$	78.43	SEVENTY EIGHT DOLLARS & 43/100		
c	24 inch	If	\$	140.14	ONE HUNDRED FORTY DOLLARS & 14/100		
d	30 inch	If	\$	217.80	TWO HUNDRED SEVENTEEN DOLLARS & 80/100		
54	HDPE DR 21						
a	12 inch	If	\$	39.16	THIRTY NINE DOLLARS & 16/100		
b	18 Inch	If	\$	78.43	SEVENTY EIGHT DOLLARS & 43/100		
c	24 inch	If	\$	140.14	ONE HUNDRED FORTY DOLLARS & 14/100		
d	30 inch	If	\$	217.80	TWO HUNDRED SEVENTEEN DOLLARS & 80/100		
55	Ductile Iron Pipe						
a	4 inch	If	\$	20.70	TWENTY DOLLARS & 70/100		
b	6 inch	If	\$	22.34	TWENTY TWO DOLLARS & 34/100		
c	8 inch	If	\$	27.86	TWENTY SEVEN DOLLARS & 86/100		
d	10 inch	If	\$	35.98	THIRTY FIVE DOLLARS & 98/100		
e	12 inch	If	\$	46.10	FORTY SIX DOLLARS & 10/100		
f	18 inch	If	\$	94.46	NINETY FOUR DOLLARS & 46/100		
g	24 inch	ea	\$	145.67	ONE HUNDRED FORTY FIVE DOLLARS & 67/100		
h	30 inch	ea	\$	222.80	TWO HUNDRED TWENTY TWO DOLLARS & 80/100		

**SWORN STATEMENT UNDER SECTION 287.133(3)(a)
FLORIDA STATUTES, ON PUBLIC ENTITY CRIMES**

PROJECT ITB #10-015: GENERAL SERVICES CONTRACT

THIS FORM MUST BE SIGNED IN THE PRESENCE OF A NOTARY PUBLIC OR OTHER OFFICE AUTHORIZED TO ADMINISTER OATHS.

1. This sworn statement is submitted with Bid, Bid or Contract No. 10-015 for General Services Contract

2. This sworn statement is submitted by CHARLEY TOPPINO & SONS, INC.
(Name of entity submitting sworn statement)
whose business address is P.O. Box 787 Key West, FL 32044
and (if applicable) its Federal Employer Identification Number (FEIN) is 592426906 (If the entity has no FEIN, include the Social Security Number of the individual signing this sworn statement.)

3. My name is Frank P. Toppino and my relationship to
(Please print name of individual signing)
the entity named above is President

4. I understand that a "public entity crime" as defined in Paragraph 287.133(1)(g), Florida Statutes, means a violation of any state or federal law by a person with respect to and directly related to the transaction of business with any public entity or with an agency or political subdivision of any other state or with the United States, including but not limited to, any Bid or contract for goods or services to be provided to any public entity or an agency or political subdivision of any other state or of the United States and involving antitrust, fraud, theft, bribery, collusion, racketeering, conspiracy, material misrepresentation.

5. I understand that "convicted" or "conviction" as defined in Paragraph 287.133(1)(b), Florida Statutes, means a finding of guilt or a conviction of a public entity crime, with or without an adjudication of guilt, in any federal or state trial court of record relating to charges brought by indictment information after July 1, 1989, as a result of a jury verdict, nonjury trial, or entry of a plea of guilty or nolo contendere.

6. I understand that an "affiliate" as defined in Paragraph 287.133(1)(a), Florida Statutes, means
 1. A predecessor or successor of a person convicted of a public entity crime: or
 2. An entity under the control of any natural person who is active in the management of the entity and who has been convicted of a public entity crime. The term "affiliate" includes those officers, directors, executives, partners, shareholders, employees, members, and agents who are active in the management of an affiliate. The ownership by one person of shares constituting controlling interest in another person, or a pooling of equipment or income among persons when not for fair market value under an arm's length agreement, shall be a prima facie case that one person controls another person. A person who knowingly enters into a joint venture with a person who has been convicted of a public entity crime in Florida during the preceding 36 months shall be considered an affiliate.

7. I understand that a "person" as defined in Paragraph 287.133(1)(8), Florida Statutes, means any natural person or entity organized under the laws of any state or of the United States with the legal power to enter into a binding contract and which Bids or applies to Bid on contracts for the provision of goods or services

let by a public entity, or which otherwise transacts or applies to transact business with a public entity. The term "person" includes those officers, directors, executives, partners, shareholders, employees, members, and agents who are active in management of an entity.

8. Based on information and belief, the statement, which I have marked below, is true in relation to the entity submitting this sworn statement. (Please indicate which statement applies.)

Neither the entity submitting this sworn statement, nor any officers, directors, executives, partners, shareholders, employees, members, or agents who are active in management of the entity, nor any affiliate of the entity have been charged with and convicted of a public entity crime subsequent to July 1, 1989.

The entity submitting this sworn statement, or one or more of the officers, directors, executives, partners, shareholders, employees, members, or agents who are active in management of the entity, or an affiliate of the entity has been charged with no convicted of a public entity crime subsequent to July 1, 1989, AND (Please indicate which additional statement applies.)

There has been a proceeding concerning the conviction before a hearing of the State of Florida, Division of Administrative Hearings. The final order entered by the hearing officer did not place the person or affiliate on the convicted vendor list. (Please attach a copy of the final order.)

The person or affiliate was placed on the convicted vendor list. There has been a subsequent proceeding before a hearing officer of the State of Florida, Division of Administrative Hearings. The final order entered by the hearing officer determined that it was in the public interest to remove the person or affiliate from the convicted vendor list. (Please attach a copy of the final order.)

The person or affiliate has not been put on the convicted vendor list. (Please describe any action taken by or pending with the Department of General Services.)

Frank P. Toppino
(Signature)
Sept. 27, 2010
(Date)

STATE OF FL
COUNTY OF Monroe

PERSONALLY APPEARED BEFORE ME, the undersigned authority,

Frank P. Toppino who, after first being sworn by me, affixed his/her signature in the
(Name of individual signing)

space provided above on this 27 day of Sept, 2010.

My commission

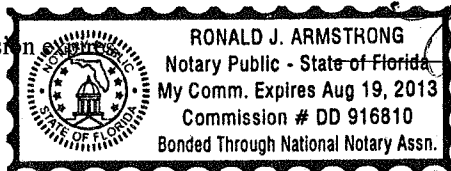

Ronald J. Armstrong
NOTARY PUBLIC

ANTI-KICKBACK AFFIDAVIT

PROJECT ITB #10-015: GENERAL SERVICES CONTRACT

STATE OF FLORIDA)
 : SS
COUNTY OF MONROE)

I, the undersigned hereby duly sworn, depose and say that no portion of the sum herein Bid will be paid to any employees of the City of Key West as a commission, kickback, reward or gift, directly or indirectly by me or any member of my firm or by an officer of the corporation.

By: Frank P. Jappese

Sworn and subscribed before me this

27 day of Sept, 2010.

Ronald J. Armstrong
NOTARY PUBLIC, State of Florida at Large

My Commission Expires: _____

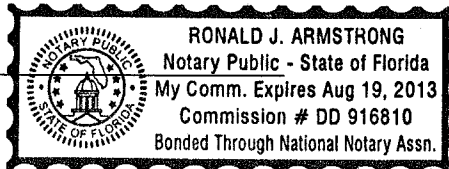

**LOCAL VENDOR CERTIFICATION PURSUANT TO CKW ORDINANCE 09-22
SECTION 2-798**

The undersigned, as a duly authorized representative of the vendor listed herein, certifies to the best of his/her knowledge and belief, that the vendor meets the definition of a "Local Business." For purposes of this section, "local business" shall mean a business which:

- a. Principle address as registered with the FL Department of State located within 30 miles of the boundaries of the city, listed with the chief licensing official as having a business tax receipt with its principle address within 30 miles of the boundaries of the city for at least one year immediately prior to the issuance of the solicitation.
- b. Maintains a workforce of at least 50 percent of its employees from the city or within 30 miles of its boundaries.
- c. Having paid all current license taxes and any other fees due the city at least 24 hours prior to the publication of the call for bids or request for proposals.
 - Not a local vendor pursuant to Ordinance 09-22 Section 2-798
 - Qualifies as a local vendor pursuant to Ordinance 09-22 Section 2-798

If you qualify, please complete the following in support of the self certification & submit copies of your County and City business licenses. Failure to provide the information requested will result in denial of certification as a local business.

Business Name **CHARLEY TOPPINO & SONS, INC.** Phone: 305 296 5606

Current Local Address: (P.O Box numbers may not be used to establish status) Fax: 305 296 5189

US Hwy #1, MM 8.5 Rockland Key
Key West, FL 33040
Length of time at this address 20 yrs

Frank P. Toppino 9/27/10
Signature of Authorized Representative Date

STATE OF FL
COUNTY OF Monroe

The foregoing instrument was acknowledged before me this 27 day of Sept, 2010.
By Frank P. Toppino, of CHARLEY TOPPINO & SONS, INC.
(Name of officer or agent, title of officer or agent) Name of corporation acknowledging)
or has produced _____ as identification

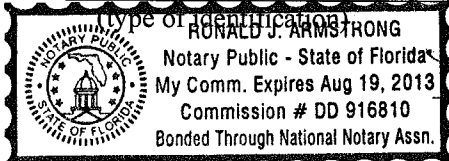

Ronald J. Armstrong
Signature of Notary
Ronald J. Armstrong
Print, Type or Stamp Name of Notary

Return Completed form with Supporting documents to:
City of Key West Purchasing

Title or Rank

CITY OF KEY WEST INDEMNIFICATION FORM

The CONTRACTOR shall indemnify and hold harmless the City of Key West, its officers, and employees, from liabilities, damages, losses and costs, including, but not limited to reasonable attorney's fees, to the extent caused by the negligence, recklessness or intentional wrongful misconduct of CONTRACTOR and persons employed or utilized by CONTRACTOR in the performance of this agreement. Except as specifically provided herein, this agreement does not require CONTRACTOR to indemnify the City of Key West, its employees, officers, directors, or agents from any liability, damage, loss, claim, action or proceeding.

These indemnifications shall survive the term of this agreement. In the event that any action or proceeding is brought against the City of Key West by reason of such claim or demand, CONTRACTOR shall, upon written notice from the City of Key West, resist and defend such action or proceeding by counsel satisfactory to the City of Key West.

The indemnification provided above shall obligate CONTRACTOR to defend at its own expense to and through appellate, supplemental or bankruptcy proceeding, or to provide for such defense, at the City of Key West's option, any and all claims of liability and all suits and actions of every name and description covered above which may be brought against the City of Key West whether performed by CONTRACTOR, or persons employed or utilized by CONTRACTOR.

The CONTRACTOR's obligation under this provision shall not be limited in any way by the agreed upon Contract Price as shown in this agreement, or the CONTRACTOR's limit of or lack of sufficient insurance protection.

CHARLEY TOPPINO & SONS, INC.

CONTRACTOR:

SEAL:

P.O. Box 787 Key West, FL
Address 33041

Frank P. Toppino
Signature

Frank P. Toppino
Print Name

President
Title

DATE:

Sept 27, 2010

CITY OF KEY WEST, FLORIDA

Business Tax Receipt

This Document is a business tax receipt
Holder must meet all City zoning and use provisions.
P.O. Box 1409, Key West, Florida 33040 (305) 809-3955

Business Name CHARLEY TOPPINO & S (FRANK RG) CTINbr:0005344
Location Addr MM 8 1/2 ROCKLAND KEY
Lic NBR/Class 10-00005340 CONTRACTOR - REG GENERAL
Issue Date: August 12, 2009 Expiration Date: September 30, 2010
License Fee \$309.75
Add. Charges \$0.00
Penalty \$0.00
Total \$309.75
Comments:

This document must be prominently displayed.

FRANK P. TOPPINO
CHARLEY TOPPINO & S (FRANK RG)
POB 787
KEY WEST FL 33041
Type: OC Drawer: 1
Date: 8/12/09 54 Receipt no: 101254
OR LIC OCCUPATIONAL 1 \$309.75
Trans number: 47678 2376119
CK CHECK \$309.75
Trans date: 8/12/09 Time: 9:58:17

CITY OF KEY WEST, FLORIDA

Business Tax Receipt

This Document is a business tax receipt

Holder must meet all City zoning and use provisions.

P.O. Box 1409, Key West, Florida 33040 (305) 809-3955

Business Name	CHARLEY TOPPINO & S. (FRANK ENG	CTINbr:0010428
Location Addr	MM 8 1/2 ROCKLAND KEY	
Lic NBR/Class	10-00017556 CONTRACTOR - REG ENGINEERING I	
Issue Date:	August 10, 2009	Expiration Date:September 30, 2010
License Fee	\$309.75	
Add. Charges	\$0.00	
Penalty	\$0.00	
Total	\$309.75	

This document must be prominently displayed.

CHARLEY TOPPINO & S (FRANK ENG
FRANK TOPPINO
P.O. BOX 787
KEY WEST FL 33041

CHARLEY TOPPINO & SONS, INC.

Oper: KENWBLD Type: OC Drawer: 1
Date: 8/10/09 54 Receipt no: 93867
2010 17556
OR LIC OCCUPATION# 1 \$309.75
Trans number: 2374376
CK CHECK 47679 \$309.75
Trans date: 8/10/09 Time: 10:27:11

CITY OF KEY WEST
CERTIFICATE OF COMPETENCY

121 THIS IS TO CERTIFY THAT

Frank Toppino
is duly registered as a
General Contractor

in conformity with the regulations of the City of Key West

Date Issued: 10/01/09 Exp. Date: 09/30/11

By: [Signature]
CHIEF BUILDING OFFICIAL

CITY OF KEY WEST
CERTIFICATE OF COMPETENCY

3064 THIS IS TO CERTIFY THAT

Frank Toppino
is duly registered as a
Engineering Contractor

in conformity with the regulations of the City of Key West

Date Issued: 10/01/09 Exp. Date: 09/30/11

By: [Signature]
CHIEF BUILDING OFFICIAL

**2009 / 2010
MONROE COUNTY BUSINESS TAX RECEIPT
EXPIRES SEPTEMBER 30, 2010**

RECEIPT# 30140-9142

Business Name: TOPPINO FRANK P

Owner Name: FRANK P TOPPINO

Mailing Address: PO BOX 787

KEY WEST, FL 33040

Business Location: US HWY 1

KEY WEST, FL 33040

305-296-5606

CONTRACTORS
(GENERAL/ENGINEERING
CONTRACTOR)

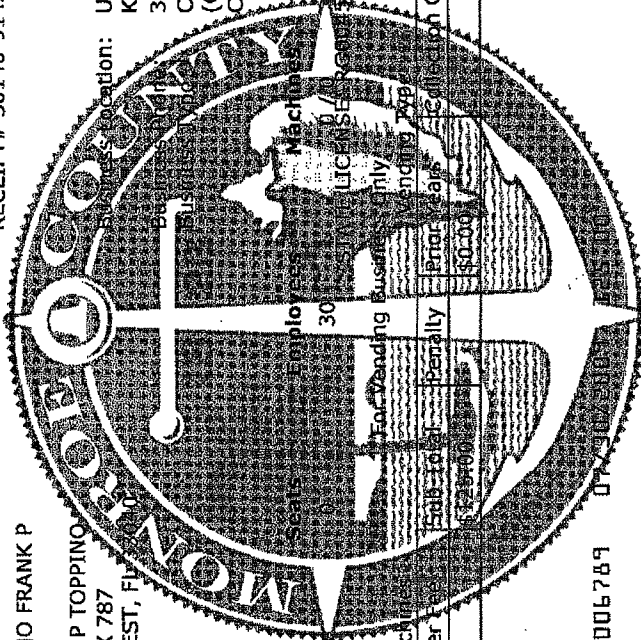

Rooms

0

Stalls

30

0
369/GC152A/ENG I 132A

Number of Machines	0	License Fee	\$0.00	Total Paid	\$125.00
Transfer Fee	\$0.00	Penalty	\$0.00	Business Cost	
Tax Amount	\$125.00	For Wandering Business	\$0.00		

PAID-105-08-00006789

THIS RECEIPT MUST BE POSTED CONSPICUOUSLY IN YOUR PLACE OF BUSINESS

THIS BECOMES A TAX RECEIPT
WHEN VALIDATED

Danise D. Henriquez, CFC, Tax Collector
PO Box 1129, Key West, FL 33041

THIS IS ONLY A TAX. YOU MUST
MEET ALL COUNTY AND/OR
MUNICIPALITY PLANNING AND
ZONING REQUIREMENTS.

MONROE COUNTY BUSINESS TAX RECEIPT

**2009 / 2010
MONROE COUNTY BUSINESS TAX RECEIPT
EXPIRES SEPTEMBER 30, 2010**

RECEIPT # 30140-89799

Business Name: CHARLEY TOPPINO & SONS, INC.

Owner Name: FRANK TOPPINO

Mailing Address: BOX 787

KEY WEST, FL 33040

Business Location:

MM 8-9 US HWY 1
KEY WEST, FL 33040

CONTRACTORS (GEN
CONT/ENGINEERING CONT)

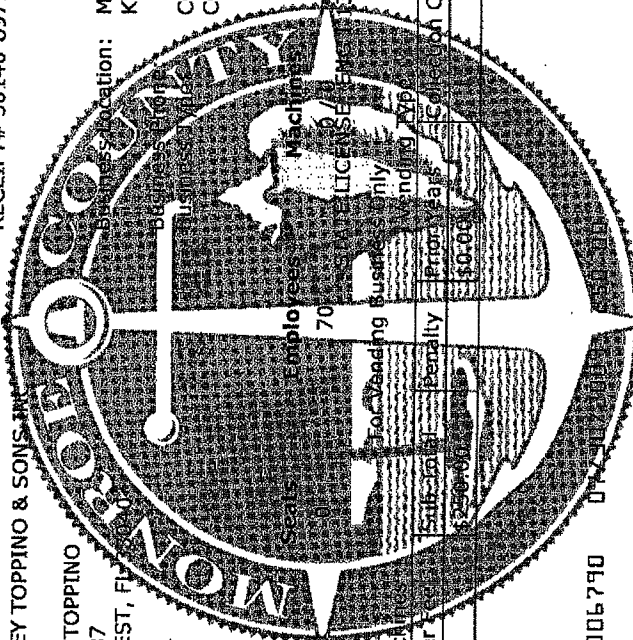

Rooms

0

Employees

70

Washing

0

Stalls

0

LICENSE # EM 131A

Number of Machines					
Transfer					
Tax Amount	\$250.00	Subtotal	\$250.00	Priority	\$0.00
		Penalty		Other	
		Cost		Total Paid	\$250.00

PAID-105-08-00006790

THIS RECEIPT MUST BE POSTED CONSPICUOUSLY IN YOUR PLACE OF BUSINESS

THIS BECOMES A TAX RECEIPT
WHEN VALIDATED

Danise D. Henriquez, CFC, Tax Collector
PO Box 1129, Key West, FL 33041

THIS IS ONLY A TAX. YOU MUST
MEET ALL COUNTY AND/OR
MUNICIPALITY PLANNING AND
ZONING REQUIREMENTS.

AC# 4482179

STATE OF FLORIDA

DEPARTMENT OF BUSINESS AND PROFESSIONAL REGULATION
CONSTRUCTION INDUSTRY LICENSING BOARD

SEQ# 109072300607

DATE	BATCH NUMBER	LICENSE NBR
07/23/2009	090041095	RG0045369

The GENERAL CONTRACTOR
Named below HAS REGISTERED
Under the provisions of Chapter 489, FS
Expiration date: AUG 31, 2011
(INDIVIDUAL MUST MEET ALL LOCAL LICENSING
REQUIREMENTS PRIOR TO CONTRACTING IN ANY AREA)

LOPPING, FRANK P
CHARLEY LOPPING & SONS INC
POST OFFICE BOX 187
KEY WEST

FL 33041-0787 WE TRUST

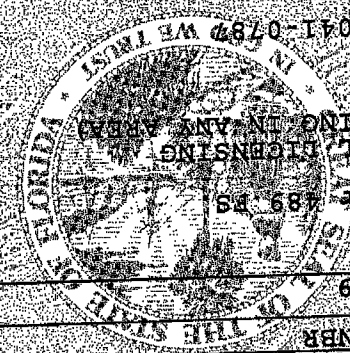

CHARLIE CRIST
GOVERNOR

DISPLAY AS REQUIRED BY LAW

CHARLES W. DRAGO
SECRETARY

AC# 4482291

STATE OF FLORIDA

DEPARTMENT OF BUSINESS AND PROFESSIONAL REGULATION
CONSTRUCTION INDUSTRY LICENSING BOARD

SEQ# 109072300719

DATE	BATCH NUMBER	LICENSE NBR
07/23/2009	090041121	0964716

The BUSINESS ORGANIZATION
Named below IS QUALIFIED
Under the provisions of Chapter 489, FS
Expiration date: AUG 31, 2011
(THIS IS NOT A LICENSE TO PERFORM WORK. THIS ALLOWS THE
COMPANY TO DO BUSINESS ONLY IF IT HAS A QUALIFIER.)

CHARLEY LOPPING & SONS INC
PO BOX 187
KEY WEST

FL 33040

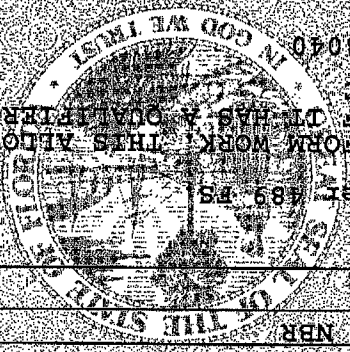

CHARLIE CRIST
GOVERNOR

DISPLAY AS REQUIRED BY LAW

CHARLES W. DRAGO
SECRETARY

1



THE CITY OF KEY WEST

525 Angela Street
Key West, FL 33040

**ADDENDUM 1:
GENERAL SERVICES CONTRACT, INVITATION TO BID # 10-015
September 24, 2010**

This addendum is issued as supplemental information to the bid package for clarification of certain matters of both a general and a technical nature. The referenced bid package is hereby addended in accordance with the following items:

1. The bid opening has been rescheduled to October 6, 2010 at 3:00 p.m.
2. A revised Bid Form is attached. Bidders shall use this form when submitting their bid.
3. A draft quantities sheet for the Pump Station F Forcemain is attached. The bidder is not required to complete this form. The form will be completed based on the unit prices bidder submits in their bid. Any item on the quantities sheet that is not listed in the Bid Form will be provided at the suppliers invoice plus 15%. Bidder will be required to submit suppliers quote prior to issuance of a Work Order.
4. Details of a Typical Trench (3123-10) and Typical Asphalt Surface repair for Trench (3123-115) are attached.

All Proposers shall acknowledge receipt and acceptance of this Addendum No. 1 by submitting the addendum with their proposal. Proposals submitted without acknowledgement or without this Addendum may be considered non-responsive.



Signature

CHARLEY TOPPINO & SONS, INC.

Name of Business

UNIT PRICE BID FORM

The Bidder agrees to accept as full payment for the work issued in a Work Order herein the amounts computed under the provisions of the Contract Documents, the City's Standard Contract Conditions, and based on the following unit price amounts. The Bidder agrees that the unit prices represent a true measure of the labor and materials required to perform the work meeting or exceeding the City of Key West's standard specifications, including all allowances for overhead/profit/insurance, etc. for each type and unit of work called for in these Contract Documents. Should there be any questions concerning the required standard, Bidder shall request clarification from the Engineer. The amounts shall be shown in both words and figures. In case of a discrepancy, the amount shown in words shall govern.

Payment for materials, equipment, testing, etc authorized by the ENGINEER in a written Work Order but not listed in the Bid Form will be provided at the suppliers invoice plus 15%.

CHARLEY TOPPINO & SONS, INC.

P.O. BOX 787

KEY WEST, FL 33041

305 296-5606

PAST PROJECTS

Please note: Frank P. Toppino and Edward Toppino, Sr., president and Secretary/Treasurer for CHARLEY TOPPINO & SONS, INC. has been involved, supervised, estimated and overseen the following projects. Paul E. Toppino and Edward Toppino, Jr. have also estimated and been involved in many of the following projects. Mr. Frank P. Toppino and Mr. Edward Toppino have been in the construction business for over 60 years each. Toppino's Inc., incorporated for 21 years, had its name change to CHARLEY TOPPINO & SONS, INC. 4 years ago.

1.) CITY OF KEY WEST
P.O. BOX 1409
KEY WEST, FL 33040
305 809-3965

SCOPE OF WORK: STORM DRAINAGE, INJECTIONS WELLS, SIDEWALKS, CURBS, FOUNDATIONS, PIER REPAIR, LANDSCAPING & MAINTENANCE, ROADWORK, ASPHALT.

PROJECTS:

RIGHT OF WAY MAINTENANCE: 1998-2009	\$2,352,000	BOND YES
CONCRETE PLACEMENT- 2002, 2005, 2007	\$2,400,000	BOND YES
WHITE STREET PIER REPAIR	\$ 88,000	BOND YES
STAPLES AVE BRIDGE	\$ 81,000	BOND YES
HOCKEY RINK	\$ 50,000	BOND YES
KAMIEN SUBDIVISION	\$1,656,000	BOND YES
SOUTHERNMOST POINT REHABILITATION	\$ 73,000	BOND YES
GENERAL SERVICES CON. 1998---2000	\$4,000,000	BOND YES
GENERAL SERVICES CON. 2002, 2005	\$2,000,000	BOND YES
GENERAL SERVICES CON. 2007	\$2,000,000	BOND YES
GRAVITY INJECTION WELLS: PHASE I	\$4,800,000	BOND YES
GRAVITY INJECTION WELLS: PHASE II	\$2,236,000	BOND YES
GRAVITY INJECTION WELLS: PHASE 5	\$1,998,385	BOND YES
GRAVITY INJECTION WELLS: PHASE 6	\$1,989,225	BOND YES
JOSE MARTI VEG REMOVAL / DRAINAGE	\$ 90,000	BOND NO
SMATHERS BEACH LANDSCAPING	\$ 100,000	BOND YES
DONALD AVE DRAINAGE SWALE	\$ 61,000	BOND NO
HURRICANE GEORGES CLEANUP	\$ 431,000	BOND NO
MITIGATION FLOW PROJECT	\$2,100,000	BOND YES
HARBOR WALK KW BIGHT	\$3,040,000	BOND YES
DINGY DOCKS 2001	\$ 104,000	BOND YES
WHITE ST PIER RIP RAP	\$ 131,054	BOND YES
FLAGLER AVE PHASE 1 & 2	\$1,391,000	BOND YES
WHITE ST PUMP STATION	\$1,645,000	BOND YES

2.) MONROE COUNTY
1100 SIMONTON STREET
KEY WEST, FL 33040
305 292-4426

SCOPE OF WORK: SITE WORK, STORM DRAINAGE, INJECTIONS WELLS, SIDEWALKS, CURBS, LANDSCAPING, ROADWORK, ASPHALT, PLAYGROUNDS.

PROJECTS:

PALM AVE ROADWAY	\$ 931,000	BOND YES
WILHELMINA PARK	\$ 145,000	BOND YES
MARATHON AIRPORT TAXILANES, T HANGER DEV.	\$2,366,000	BOND YES
MARATHON AIRPORT SERVICE ROAD	\$ 688,000	BOND YES
KW INTN AIRPORT: EXOTIC VEGETATION REMOVE	\$ 192,000	BOND YES
KW INTN AIRPORT: PARKING LOTS	\$ 531,000	BOND YES
BIG COPPITT PARK	\$ 860,242	BOND YES
BIG PINE BASIN FILL IN AND DEMO	\$ 904,943	BOND YES
MARATHON AIRPORT APRONS	\$ 376,344	BOND YES
PRADO CIRCLE	\$ 339,000	BOND YES
PALM DR BRIDGE REPAIR	\$ 131,000	BOND NO

3.) FLORIDA DEPT OF TRANSPORTATION
605 Suwannee Street
Tallahassee, FL 32399-0450
(850) 414-4000

SCOPE OF WORK: SITE WORK, DEMOLITION, STORM DRAINAGE, SANITARY SEWER, INJECTIONS WELLS, SIDEWALKS, CURBS, ROADWORK, ASPHALT, HURRICANE CLEANUP, RIP-RAP INSTALL,

TRUMAN AVE PROJECT:	\$10,500,000	BOND YES
BIG COPPITT BIKE PATH:	\$ 480,000	BOND YES
EMERGENCY ROAD REPAIRS, HURR WILMA:	\$ 185,000	BOND NO
HURRICANE GEORGES ROAD REPAIRS:	\$ 52,000	BOND NO
KNIGHTS KEY	\$ 373,000	BOND YES
BIG COPPITT BOAT RAMP & SPANISH HARBOR:	\$ 500,000	BOND NO
BIKE PATH SADDLE BUNCH KEYS	\$ 450,000	BOND YES
BOCA CHICA SEAGRASS MITIGATION	\$ 1,352,930	BOND YES

3.) SAUER INC.
11223 PHILLIPS PARKWAY DR EAST
JACKSONVILLE, FL 32256-15274
904 262-6444

SCOPE OF WORK: SITE WORK, DEMOLITION, STORM DRAINAGE, SANITARY SEWER, INJECTIONS WELLS, SIDEWALKS, CURBS, ROADWORK, ASPHALT.

PROJECTS:

CONTROL TOWER, BOCA CHICA NAS	\$832,000	BOND YES
WEATHER STATION, KEY WEST	\$366,000	BOND YES
NAVAL RESEARCH LAB	\$100,000	BOND NO
REPAIR MARINE OPS, COAST GUARD	\$337,000	BOND NO

4.) FLORIDA KEY AQUADUCT AUTHORITY
1100 KENNEDY DRIVE
KEY WEST, FL 33040
305 296-2454

SCOPE OF WORK: SITE WORK, STORM DRAINAGE, SIDEWALKS, CURBS, ROADWORK, ASPHALT, STEEL BUILDING, WATER MAINS, DEMOLITION.

PROJECTS:

FCAA CONSTRUCTION YARD BUILDING	\$ 682,000	BOND YES
PUMP STATION	\$ 377,555	BOND YES
BIG COPPITT WASTE WATER SYSTEM	\$11,078,347	BOND YES
DEMO WATER TANKS, BIG COPPITT	\$ 55,000	BOND YES
FLAGLER AVE WATERMAIN	\$ 306,861	BOND YES

5.) GULF BUILDERS
P.O. BOX 668307
POMPANO BEACH, FL 33066
954 583-5115

SCOPE OF WORK: SITE WORK, STORM DRAINAGE, SANITARY SEWER, WATER MAINS, INJECTIONS WELLS, SIDEWALKS, CURBS, ROADWORK, PARKING LOTS, ASPHALT.

PROJECTS:

ROOSEVELT GARDENS HOUSING PROJECT	\$1,256,000	BOND	YES
-----------------------------------	-------------	------	-----

6.) BJ&K CONSTRUCTION
970 WEST MCNAB ROAD
FORT LAUDERDALE, FL 33309
954 974-7744

SCOPE OF WORK: SITE WORK, DEMOLITION, STORM DRAINAGE, SANITARY SEWER, WATER MAINS, INJECTIONS WELLS, SIDEWALKS, CURBS, ROADWORK, PARKING LOTS, ASPHALT.

PROJECTS:

MERIDIAN WEST APARTMENTS	\$1,700,000	BOND	YES
--------------------------	-------------	------	-----

7.) HEERY INTERNATIONAL
1625 DENNIS STREET
KEY WEST, FL 33040
305 293-3008

SCOPE OF WORK: SITE WORK, DEMOLITION, STORM DRAINAGE, SANITARY SEWER, WATER MAINS, INJECTIONS WELLS, GAS LINES, SIDEWALKS, CURBS, ROADWORK, PARKING LOTS, ASPHALT.

PROJECTS:

KEY WEST HIGH SCHOOL REPLACEMENT: PHASES 1, 2, 3	\$633,000	BOND YES
POINCIANA ELEMENTARY SCHOOL:	\$2,240,000	BOND YES

8. COASTAL CONSTRUCTION
5959 BLUE LAGOON DR
STE 200
MIAMI, FL 33126
305 559-4900

SCOPE OF WORK: SITE WORK, DEMOLITION, FILL, CONCRETE FLATWORK, COLUMNS, RETAINING WALLS, CURBS, ROADWORK, PARKING LOTS, ASPHALT.

PROJECTS:

SUGARLOAF ELEMENTARY SCHOOL:	\$2,300,000	BOND YES
BEACHSIDE CONDOS	\$2,665,000	BOND YES
POINCIANA ROYALE	\$ 524,520	BOND YES

9.) HISTORIC TOURS OF AMERICA
201 FRONT STREET
Key West, Florida 33040
305 296-3609

SCOPE OF WORK: SITE WORK, DEMOLITION, STORM DRAINAGE, SANITARY SEWER, WATER MAINS, INJECTIONS WELLS, GAS LINES, SIDEWALKS, CURBS, ROADWORK, PARKING LOTS, ASPHALT.

PROJECTS:

PARK VILLAGE	\$ 317,000	BOND NO
MARQUESA COURT	\$ 405,000	BOND NO
KEY COVE LANDINGS	\$ 675,000	BOND NO

10.) DEMOYA GROUP
12209 S. DIXIE HWY
MIAMI, FL 33156
305 255-5713

SCOPE OF WORK: STORM DRAINAGE , INJECTIONS WELLS, ROAD BASE, CONCRETE WORK.

PROJECTS:

SOUTH ROOSEVELT BLVD. REHAB	\$1,507,000.00	BOND NO (SUB)
BIG COPPITT US 1 ROAD EXPANSION	\$ 2,157,000	BOND NO (SUB)

11.) DL PORTER
6574 PALMER CIRCLE
SARASOTA, FL 34238
941 929-9400

SCOPE OF WORK: SITE WORK, DEMOLITION, STORM DRAINAGE, SANITARY SEWER, WATER MAINS, INJECTIONS WELLS, GAS LINES, SIDEWALKS, CURBS, ROADWORK, PARKING LOTS, ASPHALT.

PROJECTS:

HOMELAND SECURITY, KEY WEST	\$ 231,600.00	BOND NO
KEY WEST INTERNATIONAL AIRPORT	\$ 724,000.00	BOND NO
SANTA MARIA HOTEL	\$ 225,000.00	BOND NO
COUCH HARBOR	\$ 210,000.00	BOND NO
ATLANTIC SHORES DEMO & SITEWORK	\$1,011,000.00	BOND NO
TRUMAN HOTEL SITEWORK	\$ 55,000.00	BOND NO

12. HARRY PEPPER & ASSOCIATES
215 CENTURY 21 DRIVE
JACKSONVILLE, FL 32216
904 721-3300

SCOPE OF WORK: SITE WORK, DEMOLITION, STORM DRAINAGE, SANITARY SEWER, WATER MAINS, INJECTIONS WELLS, GAS LINES, SIDEWALKS, CURBS, ROADWORK, PARKING LOTS, ASPHALT.

PROJECTS:

REPAIR BASE OPERATIONS, BOCA CHICA	\$601,000	BOND NO
ELLISON DRIVE, TRUMBO POINT	\$ 116,000	BOND NO
BEQ, TRUMAN ANNEX	\$ 70,000	BOND NO
JIAFT EAST WAREHOUSE	\$462,000	BOND NO

13. BRPH
3275 SUNTREE BLVD
MELBOURNE, FL 32940

SCOPE OF WORK: SITE WORK, DEMOLITION, STORM DRAINAGE, SANITARY SEWER, WATER MAINS, INJECTIONS WELLS, GAS LINES, SIDEWALKS, CURBS, ROADWORK, PARKING LOTS, ASPHALT.

PROJECTS:

ECO DISCOVERY CENTER	\$ 50,000	BOND NO
BOCA CHICA FITNESS CENTER	\$ 36,000	BOND NO
MARINA BY PASS ROAD, BOCA	\$348,000	BOND NO
TACTS BUILDING, BOCA CHICA	\$ 32,000	BOND NO
NANCY FOSTER ENVIRONMENTAL CTR	\$541,000	BOND NO
BLDG. # 324 PARKING	\$93,000	BOND NO

14. DOOLEY MACK CONTRACTORS
5800 LAKEWOOD RANCH BLVD.
SARASOTA, FL 34240
941 921-4636

SCOPE OF WORK: SITE WORK, DEMOLITION, STORM DRAINAGE, SANITARY SEWER, WATER MAINS, INJECTIONS WELLS, GAS LINES, SIDEWALKS, CURBS, ROADWORK, PARKING LOTS, ASPHALT.

STEAMPLANT CONDOS	\$1,332,000.00	BOND YES
THE MEADOWS, KEY WEST	\$ 145,000.00	BOND NO

15. BOTANICAL GARDENS
5210 COLLEGE ROAD
KEY WEST, FL 33040
305 296-1504

SCOPE OF WORK: DEMOLITION, , SIDEWALKS, CURBS, ROADWORK, PARKING LOTS, BOARDWALK / PILE CONSTRUCTION, BOULDER CUTTING & PLACEMENT, LAKE / POND CONSTRUCTION.

BOTANICAL GARDENS PHASE 1 POND	\$329,896.50	BOND YES
BOTANICAL GARDENS PHASE III	\$167,000.00	BOND YES

16. BALFOUR BEATTY MILITARY HOUSING MANAGEMENT LLC
10 CAMPUS BLVD.
NEWTOWN SQUARE, PA 19073
610 355-8051

SCOPE OF WORK: DEMOLITION, , SIDEWALKS, CURBS, ROADWORK, PARKING LOTS, BOARDWALK / PILE CONSTRUCTION, BOULDER CUTTING & PLACEMENT, LAKE / POND CONSTRUCTION.

RENOVATIONS FAMILY HOUSING MEDICAL CTR	\$141,350.00	BOND NO
RENOVATIONS TO QUARTERS LB, MEDICAL CTR	\$ 39,800.00	BOND NO

**17. FL DEPT OF ENVIRONMENTAL PROTECTION
3900 COMMONWEALTH BLVD.
TALLAHASSEE, FL 32399-3000
305 420-8432**

SCOPE OF WORK: BRIDGE REPAIR TO OLD OHIO BAHIA HONDA BRIDGE, MM 38.7, REPAIR ENTIRE SUPER STRUCTURE DECK, PROVIDE AND INSTALL AL PEDESTRIAN RAILING, MILL/RESURFACE AND STRIPE, SPALL / CRACK REPAIR.

OHIO BAHIA HONDA BRIDGE REPAIR: \$837,700.00 BOND YES

**18. SH MARATHON, LTD.
506 FLEMING ST.
KEY WEST, FL 33040
305 294-6100**

SCOPE OF WORK: DEMOLITION AND REBUILD OF HOTEL, RESTAURANT, MARINA AND BOAT SLIPS IN MARATHON, FL. HOLIDAY INN EXPRESS.

HOLIDAY INN EXPRESS: \$8,890,227 BOND YES

**19. DORADO/CONQUISTADOR
541 N. PALMATTO AVE.
SUITE 104
SANFORD, FL 32771
407 688-0600**

SCOPE OF WORK: SITEWORK, FILL REMOVAL AND PROCESSING AT THE BOCA CHICA NAVAL AIR STATION AIRFIELD.

BOCA CHICA AIRFIELD VEGETATION \$1,057,126.00 BOND YES

**20. SS RAFFERTY, LLC
3717 EAGLE AVE
KEY WEST, FL 33040**

SCOPE OF WORK: DEMOLITION, SITEWORK, BUILDING.

512 DUVAL STREET BUILDING \$1,071,586.28 BOND NO

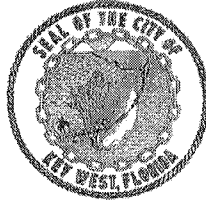

THE CITY OF KEY WEST

525 Angela Street
Key West, FL 33040

**ADDENDUM 1:
GENERAL SERVICES CONTRACT, INVITATION TO BID # 10-015
September 24, 2010**

This addendum is issued as supplemental information to the bid package for clarification of certain matters of both a general and a technical nature. The referenced bid package is hereby addended in accordance with the following items:

1. The bid opening has been rescheduled to October 6, 2010 at 3:00 p.m.
2. A revised Bid Form is attached. Bidders shall use this form when submitting their bid.
3. A draft quantities sheet for the Pump Station F Forcemain is attached. The bidder is not required to complete this form. The form will be completed based on the unit prices bidder submits in their bid. Any item on the quantities sheet that is not listed in the Bid Form will be provided at the suppliers invoice plus 15%. Bidder will be required to submit suppliers quote prior to issuance of a Work Order.
4. Details of a Typical Trench (3123-10) and Typical Asphalt Surface repair for Trench (3123-115) are attached.

All Proposers shall acknowledge receipt and acceptance of this Addendum No. 1 by submitting the addendum with their proposal. Proposals submitted without acknowledgement or without this Addendum may be considered non-responsive.

A handwritten signature in black ink, appearing to read "R. J. Am", is written over a horizontal line.

Signature

CHARLEY TOPPINO & SONS, INC.

Name of Business

UNIT PRICE BID FORM

The Bidder agrees to accept as full payment for the work issued in a Work Order herein the amounts computed under the provisions of the Contract Documents, the City's Standard Contract Conditions, and based on the following unit price amounts. The Bidder agrees that the unit prices represent a true measure of the labor and materials required to perform the work meeting or exceeding the City of Key West's standard specifications, including all allowances for overhead/profit/insurance, etc. for each type and unit of work called for in these Contract Documents. Should there be any questions concerning the required standard, Bidder shall request clarification from the Engineer. The amounts shall be shown in both words and figures. In case of a discrepancy, the amount shown in words shall govern.

Payment for materials, equipment, testing, etc authorized by the ENGINEER in a written Work Order but not listed in the Bid Form will be provided at the suppliers invoice plus 15%.

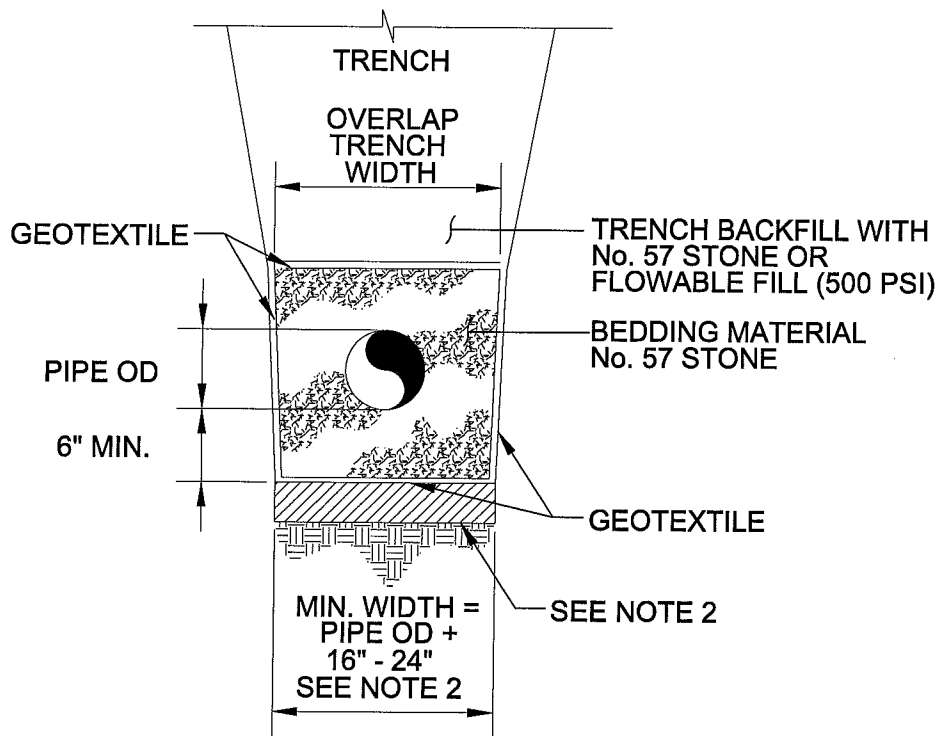

NOTES:

1. GEOTEXTILE MATERIAL SHALL BE PLACED AROUND BEDDING MATERIAL.
2. IF MUCK IS ENCOUNTERED IN TRENCH BED OVEREXCAVATE AND BACKFILL WITH A MINIMUM OF 2 FEET OF No. 57 ROCK OR FLOWABLE FILL (500 PSI).

TYPICAL TRENCH

NTS

3123-110

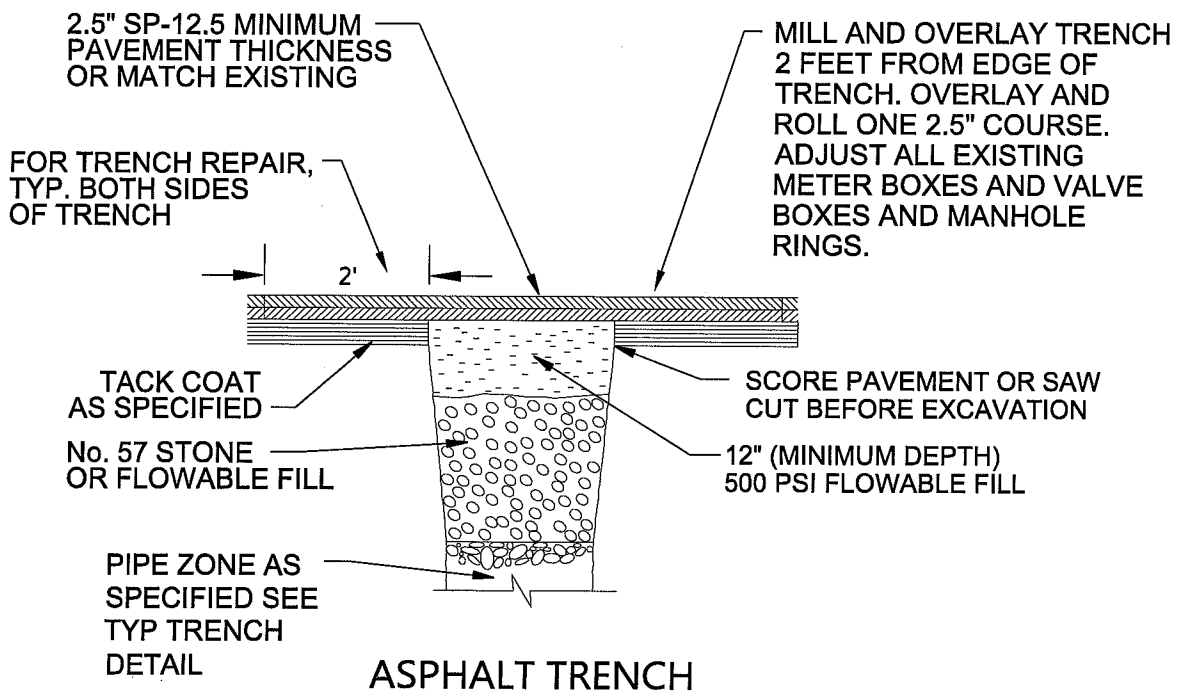

ASPHALT SURFACE REPAIR FOR TRENCH

NTS

3123-115



THE CITY OF KEY WEST

525 Angela Street
Key West, FL 33040

**ADDENDUM 2:
GENERAL SERVICES CONTRACT, INVITATION TO BID # 10-015
October 1, 2010**

This addendum is issued as supplemental information to the bid package for clarification of certain matters of both a general and a technical nature. The referenced bid package is hereby addended in accordance with the following items:

1. Attached is a an Supplementary section to the Bid Form that must be completed and submitted with the bid package
2. Draft quantities sheets for three (3) future Work Orders are attached. The Work Orders are for proposed forcemain work at Wastewater Treatment Plant Headworks and forcemain work with the George Street Stormwater Basin Improvement. The bidder is not required to complete this form. The form will be completed based on the unit prices bidder submits in their bid. Any item on the quantities sheet that is not listed in the Bid Form will be provided at the suppliers invoice plus 15%. Bidder will be required to submit suppliers quote prior to issuance of a Work Order.

All Proposers shall acknowledge receipt and acceptance of this Addendum No. 2 by submitting the addendum with their proposal. Proposals submitted without acknowledgement or without this Addendum may be considered non-responsive.

A handwritten signature in black ink, appearing to read "R. Toppino", is written over a horizontal line.

Signature

CHARLEY TOPPINO & SONS, INC.

Name of Business

SUPPLEMENTARY BID FORM

#	Item	Unit	Per Unit \$	Per Unit Word
50	Landscaping			
i	Tree removal: 8" - 10" Diameter Pine	ea		
j	Fence: 6' Chain Link w/ 3 strand Barbed wire: remove & reinstall	ea		
53	HDPE DR 17			
a	12 inch	lf		
b	18 inch	lf		
c	24 inch	lf		
d	30 inch	lf		
54	HDPE DR 21			
a	12 inch	lf		
b	18 inch	lf		
c	24 inch	lf		
d	30 inch	lf		
55	Ductile Iron Pipe			
a	4 inch	lf		

#	Item	Unit	Per Unit \$	Per Unit Word
b	6 inch	lf		
c	8 inch	lf		
d	10 inch	lf		
e	12 inch	lf		
f	18 inch	lf		
g	24 inch	ea		
h	30 inch	ea		

CONSTRUCTION ESTIMATED QUANTITIES AND BID FORM

	UNIT	QUANTITY	UNIT PRICE	TOTAL
Work Order: Headworks Piping Raw Sewage Pipeline				
Tree removal: 8"-10" Diameter Pine	EA	6		
Fence: 6' Chain Link w/ 3 strand Barbed wire: remove & reinstall	LF	456		
HDPE 30" DR 17	LF	940		
HDPE 30" DR 17 - 45 degree bend	EA	2		
Tie-in to 30" Conc encased 30" HDPE Pipe	LS	1		
Work Order: Headworks Piping Eaton & White Street				
20" Plug Valve MJ	EA	2		
20" X 20" MJ Tee	EA	1		
20" PVC C-905 SDR 25	LF	50		
30" HDPE DR-17 adapter & ring	EA	2		
30" Plug Valve MJ	EA	1		
30" x 20" MJ Tee	EA	1		
30" DI Pipe	LF	15		
Work Order: George Street Stormwater Basin Improvements				
30" C-905 PVC DR41 pipe	LF	1000		
Fitting Restraint: JCM "Sur-Grip" Restraint System Series 610	EA	10		
Joint Restraint: JCM "Sur-Grip" Restraint System Series 620/621.	EA	10		
45 degree bends	EA	10		