

**Attachment 2C**  
**ARCOSA Design and Installation Standards**

RAINWATER CATCHMENT DESIGN  
AND  
INSTALLATION STANDARDS

by

Chairman  
E. W. Bob Boulware, P.E.

Contributors:  
Timothy Pope - Dennis Lye, PhD- Billy A. Kniffen  
Joseph Wheeler - William Morris - Richard Jennings  
Jack Shultz, P.E. - Will Ed Winters, P.E. - Cado Daily- John Kight, P.E.

January 20, 2009

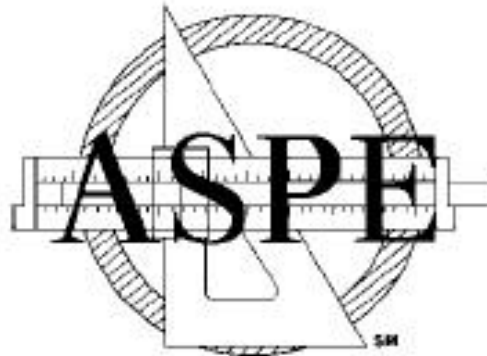

# RAINWATER CATCHMENT DESIGN AND INSTALLATION STANDARDS

## TABLE OF CONTENTS

- 1.0 General
  - 1.1 Scope
  - 1.2 Performance Objectives
  - 1.3 Units of Measurement
  - 1.4 Related Standards
  
- 2.0 Acceptable Material and Components
  - 2.1 General
  - 2.2 Related Standards
    - 2.2.1 American National Standards Institute (ANSI)
    - 2.2.2 American Society of Testing and Materials (ASTM)
    - 2.2.3 American Water Works Association (AWWA)
    - 2.2.4 Cast Iron Soil Pipe Institute (CISPI)
    - 2.2.5 American Society of Mechanical Engineers (ASME)
    - 2.2.6 Copper Development Association (CDA)
    - 2.2.7 Crane Technical Paper No. 410
    - 2.2.8 International Organization for Standardization (ISO)
    - 2.2.9 National Weather Service
    - 2.2.10 NOAA Technical Memorandums
    - 2.2.11 NSF International
    - 2.2.12 American Public Health Association
  
- 3.0 Design And Installation Requirements
  - 3.1 Collection parameters
  - 3.2. Conveyance Systems
  - 3.3 Cisterns Storage
  - 3.4 Pumping
  - 3.5 Filtration
  - 3.6 Piping
  - 3.7 Potable Rainwater Applications
  
- 4.0 Definitions
  
- 5.0 Accepted Piping Schematics

## APPENDIX

- I. Maintenance Form
- II. Calculation Format
- III. Average Rainfall Data

## RAINWATER CATCHMENT DESIGN AND INSTALLATION STANDARDS

### 1.0 SCOPE

#### 1.1 General

1.1.1 Rainwater Catchment System is defined as a system that utilizes the principal of collecting and using precipitation from a rooftop or other manmade, above ground collection surface.

1.1.2 This Rainwater Catchment Design and Installation Standard, (hereinafter referred to as the *Standard*) has been developed by a joint effort of the American Rainwater Catchment Systems Association (ARCISA) and the American Society of Plumbing Engineers (ASPE). The purpose of this standard is to assist engineers, designers, plumbers, builders / developers, local government, and end users in safely implementing a rainwater catchment system. This standard is intended to apply to new rainwater catchment installations, as well as alterations, additions, maintenance and repairs to existing installations.

1.1.3 The standards mentioned herein are intended to be consistent with, and complimentary to, the requirements of the Uniform Plumbing Code, International Plumbing Code, National Institute of Health, and local Board of Health. However, installers are advised to consult with the plumbing authority regarding local conditions, requirements and restrictions.

#### 1.2 PERFORMANCE OBJECTIVES

1.2.1 Rainwater systems are capable of producing high quality water, to levels meeting public utility standards, but only if properly maintained by the system owner or operator. The objectives of this Standard are to provide guidance in how to provide and maintain a healthy alternative to utility provided water, and to optimize rainwater utilization, while ensuring that:

- A. Consumers of rainwater are safeguarded from illness as a consequence of poor design, installation, maintenance or illegal work.
- B. The public is safeguarded from injury or loss of amenity due to a failure of the supply, installation, maintenance, or operation of the rainwater catchment system.
- C. The Rainwater System will serve to maintain and enhance the quality of the environment while ensuring compliance with the intent of relevant regulations and government officials.

1.2.2 This Standard applies to the following applications

- A. Non-Potable
- B. Potable
- C. Fire Protection
- D. Agricultural
- E. Industrial

#### 1.3 UNITS OF MEASUREMENT

1.3.1 Values are stated in U.S. Customary Units and shall be considered as the standard.

## RAINWATER CATCHMENT DESIGN AND INSTALLATION STANDARDS

### 1.4 RELATED STANDARDS

1.4.1 NSF International Protocol P151: Health Effects From Rainwater Catchment System Components.

1.4.2 NSF / ANSI 61: Drinking Water System Health Effects.

## RAINWATER CATCHMENT DESIGN AND INSTALLATION STANDARDS

### 2.0 ACCEPTABLE MATERIALS AND COMPONENTS

#### 2.1 General

2.1.1 The following standards are referenced in this document.

2.1.2 The listing of a reference in this consensus standard shall imply the application of the latest issue, revision or affirmation, including all referenced documents listed therein.

#### 2.2 Related Standards

##### 2.2.1 American National Standards Institute (ANSI)

- A. ANSI A21.10 ANSI Standards for Ductile-Iron and Gray-Iron Fittings.
- B. ANSI B16.22 Wrought Copper and Copper Alloy Solder Joint Pressure Fittings.

##### 2.2.2 ASTM International (ASTM)

- A. ASTM B 32 Specifications for Solder Metal.
- B. ASTM B 75 Specifications for Seamless Copper Tub.
- C. ASTM B 828 Practice for Making Capillary Joints by Soldering of Copper and Copper Alloy Tube and Fittings
- D. ASTM B 638 Test Method for Tensile Properties of Plastics.
- E. ASTM B 695 Test Method for Compressive Properties of Rigid Plastics.
- F. ASTM D 1599 Test Method for Resistance to Short-Time Hydraulic Pressure of Plastic Pipe, Tube and Fittings.
- G. ASTM D 1600 Terminology for Abbreviated Terms Relating to Plastics.
- H. ASTM 1785 Standard Specification for Poly Vinyl Chloride (PVC) Plastic Pipe, Schedule 40, 80, and 120.
- I. ASTM D 2104 Specification for Polyethylene (PE) Plastic Pipe, Schedule 40.
- J. ASTM D 2241 Specification for Poly Vinyl Chloride (PVC) Pressure Plastic Pipe.
- K. ASTM D 2282 Specification for Acrylonitrile-Butadiene-Styrene (ABS) Plastic Pipe (SDR-PR).
- L. ASTM 2466 Standard Specification for Poly Vinyl Chloride (PVC) Plastic Fittings, schedule 40.
- M. ASTM 2467 Standard Specification for Poly Vinyl Chloride (PVC) Plastic Fittings, Schedule 80.

## RAINWATER CATCHMENT DESIGN AND INSTALLATION STANDARDS

- N. ASTM D 2447 Specification for Polyethylene (PE) Plastic Pipe, Schedules 40 and 80, Based on Outside Diameter.
- O. ASTM D 2468 Specification for Acrylonitrile-Butadiene-Styrene (ABS) Plastic Pipe Fittings, Schedule 40.3838
- P. ASTM D 2657 Practice for Heat-Joining Polyolefin Pipe and Fittings.
- Q. ASTM D 2661 Specification for Acrylonitrile-Butadiene-Styrene (ABS) Schedule 40 Plastic Drain, Waste, and Vent Pipe and Fittings.
- R. ASTM D 2665 Specification for Poly (Vinyl Chloride) (PVC) Plastic Drain, Waste, and Vent Pipe and Fittings.
- S. ASTM D 2855 Practice for Making Solvent-Cemented Joints with Poly (Vinyl Chloride) (PVC) Pipe and Fittings.
- T. ASTM D 2949 Specification for 3.25-in. Outside Diameter Poly (Vinyl Chloride)(PVC) Plastic Drain, Waste, and Vent Pipe and Fittings.
- U. ASTM D 3261 Specification for Butt Heat Fusion Polyethylene (PE) Plastic Fittings for Polyethylene (PE) Plastic Pipe and Tubing.
- V. ASTM D 3311 Specification for Drain, Waste, and Vent (DWV) Plastic Fittings.
- W. ASTM D 3350 Specification for Polyethylene Plastics Pipe and Fittings Materials.
- X. ASTM E 84 Test Method for Surface Burning Characteristics of Building Materials.
- Y. ASTM E 412 Terminology Relating to Plastic Piping Systems.
- Z. ASTM F 628 Specification for Acrylonitrile-Butadiene-Styrene (ABS) Schedule 40 Plastic Drain, Waste, and Vent Pipe With a Cellular Core.
- Aa. ASTM F 714 Specification for Polyethylene (PE) Plastic Pipe (SDR-PR) Based on Outside Diameter.
- Bb. ASTM F 1866 Specification for Poly (Vinyl Chloride) (PVC) Plastic Schedule 40 Drainage and DWV Fabricated Fittings.
- Cc. ASTM F 1901 Specification for Polyethylene (PE) Pipe and Fittings for Roof Drain Systems.

### 2.2.3 American Water Works Association (AWWA)

- A. AWWA C110 Standard for Ductile-Iron and Gray-Iron Fittings, 3 in. - 48 in. (76 mm-1,219 mm), for Water C606 Grooved and Shouldered Joints.
- B. AWWA C.606 Grooved and Shoulder Joints.

## RAINWATER CATCHMENT DESIGN AND INSTALLATION STANDARDS

- 2.2.4 Cast Iron Soil Pipe Institute (CISPI)
  - A. CISPI 301 Standard Specification for Hubless Cast Iron Soil Pipe and Fittings for Sanitary and Storm Drain, Waste and Vent Piping Applications (ASTM B 888).
  - B. CISPI 310 Specification for Couplings for Use In Connection With Hubless Cast Iron Soil Pipe and Fittings For Sanitary and Storm Drain Waste and Vent Piping Applications.
- 2.2.5 American Society of Mechanical Engineers (ASME)
  - A. ASME A 112.6.4 Roof, Deck and Balcony Drains.
- 2.2.6 Copper Development Association (CSA)
  - A. Copper Tube Handbook.
- 2.2.7 Crane Technical Paper No. 410, - Flow of Fluids Through Valves, Fittings and Pipe, @ 1988.
- 2.2.8 International Organization for Standardization (ISO)
  - A. ISO 899 Plastics- Determination of Tensile Creep Behavior.
- 2.2.9 National Weather Service
  - A. NWS HYDRO-35 Five to Sixty Minute Precipitation Frequency of the Eastern and Central United States.
  - B. National Climate Data Center <http://www.ncdc.noaa.gov/oa/ncdc.html>
- 2.2.10 NOAA Technical Memorandum
  - A. NOAA Short Duration Rainfall Frequency Relations for California.
  - B. NOAA Short Duration Rainfall Frequency Relations for the Western United States.
- 2.2.11 NSF International
  - A. Protocol P151: Health Effects from Rainwater Catchment System Components.
  - B. NSF / ANSI Standard 14: Plastic Piping System Components and Related Materials.
  - C. NSF / ANSI Standard 42: Drinking Water Treatment Units--Aesthetic Effects.
  - D. NSF / ANSI Standard 53: Drinking Water Treatment Units-- Health Effects.



## RAINWATER CATCHMENT DESIGN AND INSTALLATION STANDARDS

- E. NSF / ANSI Standard 55: Ultraviolet Microbiological Water Treatment Systems.
- F. NSF / ANSI Standard 58: Reverse Osmosis Drinking Water Treatment Systems.
- G. NSF / ANSI Standard 60: Drinking Water System Chemicals Health Effects.
- H. NSF / ANSI Standard 61: Drinking Water System Components Health Effects

### 2.2.12 American Public Health Association

- A. Standard Methods for the Examination of Water and Wastewater.

## RAINWATER CATCHMENT DESIGN AND INSTALLATION STANDARDS

### 3.0 DESIGN AND INSTALLATION REQUIREMENTS

#### 3.1 Collection Parameters.

3.1.1 All piping and plumbing component materials used in the installation of a rainwater harvesting system shall be as approved for the specific use per local plumbing code, or be listed by an ANSI/ NSF accredited product certification program as available.

- A. Collection roofing, gutters, piping, fittings, valves, screens, down spouts, leaders, flushing devices, tanks, and liners, shall be approved for the intended use.
- B. All tank interior surfaces, and equipment shall be washed clean before they are put into service.
- C. For water storage volumes less than 200 gallons, or intended for minor utility, irrigation and garden use, no treatment is required.
- D. Water level control devices that control pumps, makeup water valves, etc, in contact with the water supply, shall be mercury free devices.
- E. Overhanging vegetation and proximity to air borne pollution sources are to be avoided.
- F. These standards do not apply to the collection of rainwater from vehicular parking or other similar surfaces.

3.1.2 For non-potable water applications,

- A. The collection surface may be constructed of any aboveground, hard surface, impervious material.
- B. Harvested rainwater must be filtered or treated to an appropriate quality suitable for intended use. No treatment is required for sub surface irrigation, agricultural, or garden use. For above surface Irrigation, the local authority having jurisdiction should be consulted regarding required water quality.

#### 3.2 Conveyance System

3.2.1 The Roof Drainage System. Gutters and downspouts used to collect rainwater shall comply with the following:

- A. All piping, plumbing components, and material used shall be manufactured of material approved for the intended application, conforming to the standards described herein in Chapter 2, and meeting the intent of applicable Building and Plumbing Codes.
- B. Gutter and down spout systems leading to the cistern shall be fitted with debris excluder or equivalent device.

## RAINWATER CATCHMENT DESIGN AND INSTALLATION STANDARDS

3.2.2 Washers and Pre-filtration. All collected rainwater, for potable water application, shall pass through a roof washer or pre-filtration system before the water enters the cistern(s). Roof washer systems shall meet the following design requirements:

- A. A sufficient amount of rainwater shall be wasted, and not allowed to enter the cistern, to wash accumulated debris from collection surface. Approximate amount of rainfall to be wasted shall be adjustable as necessary to minimize cistern water contamination. (See Chapter Five, *Acceptable Piping Schematics*, for guidance in determining pre-wash water volume)
- B. The inlet to the roof washer shall be provided with a debris screen that protects the roof washer from the intrusion of waste and vermin. The debris screen shall be corrosion resistant and shall have openings no larger than 0.5 inches and no smaller than 0.25 inches nominal. Pre-filters which have a self-cleaning design are not required to have the aforementioned debris screen.

Exception: This item is not required for pre-filters which provide their own method of diverting the prescribed first flush.

- C. Water drained from the first-flush diverter or pre-filter will be piped away from the storage tank and terminate in a location which will not cause damage to property or cause erosion.
- D. If more than one cistern is used a screen, roof washer or pre-filtration system shall be provided for each cistern.  
  
Exception: Where cisterns are interconnected to supply water in series, a single pre filter will be permitted.
- E. First flush diverters and pre-filters shall be provided with an automatic means of self draining between rain events.
- F. Roof washers shall be readily accessible for regular maintenance.
- G. Pre-filtration screens or filters shall be maintained consistent with manufacturer's specifications.

3.3 CISTERNS / STORAGE. The following are the minimum requirements for cisterns:

3.3.1 General:

- A. Cisterns may be used as storm-water collection points that help to minimize flood damage, while providing a reservoir for later use. Cisterns shall have access to allow inspection and cleaning.

## RAINWATER CATCHMENT DESIGN AND INSTALLATION STANDARDS

- 3.3.2 Installation: Cisterns may be installed either above or below grade
- A. Tank shall comply with the Administrative Authority having jurisdiction, local building codes and ordinances, and / or as certified by a structural engineer.
  - B. Above grade plastic tanks shall be certified by the manufacturer for intended application.
  - C. Above grade cisterns shall be protected from direct sunlight and shall:
    - 1. Be constructed using opaque, UV resistant, materials: i.e. heavily tinted plastic, lined metal, concrete, wood, or painted to prevent algae growth,  

or
    - 2. Have specially constructed sun barriers e.g. installed in garages, crawlspaces, sheds, etc.
  - D. Below grade cisterns, located outside of the building, shall be provided with manhole risers a minimum of 4 inches above surrounding grade and / or installed in such a way as to prevent surface or ground water from entering through the top of any fittings.
  - E. Where the installation requires a foundation, the foundation shall be flat and shall be designed to support the cistern weight when the cistern is full consistent with bearing capability of adjacent soil.
  - F. In areas where sustained freezing temperatures occur, provisions will be made to keep cistern and the related piping from freezing.
  - G. All cisterns shall be installed in accordance with the manufacturer's installation instructions.
    - 1. Underground tanks shall comply with OSHA's construction Industry Standards Part 1926 Subpart P, Fall protection rules and regulations and any local codes relating to excavation and backfill technique or safety.
    - 2. Above grade tanks shall be installed on a sturdy and level, foundation or platform, adequately secured with adequate drainage.
  - H. In a situation where the soil can become saturated, an underground tanks shall be ballasted, or otherwise secured, to prevent the tank from floating out of the ground when empty. The combined weight of the tank and hold down ballast should meet or exceed the buoyancy force of the tank, calculated as follows:

## RAINWATER CATCHMENT DESIGN AND INSTALLATION STANDARDS

Example:

1. Buoyant force of Cistern (lbs) =

Cistern Volume (cubic feet) x 62.4 (lbs / cubic foot) e.g.

For 1000 gallon tank, Buoyant force will be 1000 gallons x

(1 cubic foot / 7.48 gallons) x 62.4 ( lbs / cubic foot)

= 8342 lbs

2. If concrete used as ballast, the volume needed will be:

Volume (cubic feet) = 8342 lbs x cubic feet / 150 lbs

= 55.6 cubic feet (2.1 cubic yards)

- I. Cisterns shall be provided with a means for draining and cleaning.
- J. All cistern openings shall be protected from unintentional entry by humans or vermin. Manhole covers shall be provided and shall be secured to prevent tampering.
  1. Where an opening is provided that could allow the entry of personnel, the opening shall be marked,

"DANGER - CONFINED SPACE".

### 3.3.3 Inlets, Outlets and Openings.

- A. Cistern inlets shall be provided to permit water to enter tank with minimum turbulence.
- B. The overflow outlet, or flap valve, shall be protected with a screen having openings no greater than 0.125 inches, or as otherwise appropriate, for preventing entrance of insects or vermin entering the cistern.
  1. Overflow outlet shall be sized in accordance with prevailing gutter and down spout requirements.
  2. Water from the cistern overflow shall be discharged in a manner consistent with local storm water runoff requirements and as approved by the local authority having jurisdiction, or may be allowed to infiltrate excess collected water into the aquifer.

## RAINWATER CATCHMENT DESIGN AND INSTALLATION STANDARDS

### 3.4 PUMP.

- 3.4.1 Where a pump is provided in conjunction with the rainwater harvesting system, the pump shall meet the following provisions:
- A. The pump and all other pump components shall be listed and approved for use with potable water systems.
  - B. The pump shall be capable of delivering a minimum of 15-psig residual pressure at the highest and / or most remote outlet served. Minimum pump pressure shall allow for friction and other pressure losses. Maximum pressures shall not exceed 80 psig. A pressure-reducing valve shall be provided at water branch distribution piping if the pump is capable of exceeding 75 psig.

### 3.5 FILTRATION. Filtration shall meet the following provisions

- 3.5.1 Where rainwater is used for non-potable use and for non-critical operations, such as irrigation, wash down, etc., a final stage filtration system is not required.
- 3.5.2 Where rainwater is used for non-potable use, interior to an occupied facility, for makeup for laundry, toilets, process, etc.; the water is to be filtered as a safeguard against sediment or discoloration, and for proper operation of valves or other devices.

### 3.6 PIPING

- 3.6.1 There shall be no direct connection of any rainwater harvesting pipe system and a public utility- provided domestic potable water pipe system without an approved back flow device.
- 3.6.2 Separation shall be maintained between potable and non-potable water systems at all times. Cross connections, without proper protection in accordance with local applicable plumbing code, will not be permitted.
- A. All material used as part of a rainwater harvesting system shall be as listed for the purpose intended, as designated by local applicable code.
  - B. Where rainwater harvesting pipe and potable water pipe are installed in the same trench, wall cavity, or other location, the potable water pipe shall be separated by a minimum distance of twelve inches (12") above the rainwater -harvesting pipe. Both pipes shall be installed below local frost depth.
- 3.6.3 Piping Materials.
- A. Rainwater distribution water piping, fittings and other related system components shall be suitable for domestic water application as indicated in the applicable local building and / or plumbing code, or as otherwise described in Section 2.
  - B. Plastic piping shall be protected from UV radiation by a factory apply protective coating, or painted with a compatible latex paint. Piping and solvent cements shall be approved for the intended use.

## RAINWATER CATCHMENT DESIGN AND INSTALLATION STANDARDS

- 3.6.4 Labeling. If a Rainwater Harvesting System is applied to any building, facility or residence, it shall be so indicated as follows:
- A. All rainwater-supplied fixtures, not specifically treated for potable water use, shall be prominently labeled  

“NON-POTABLE - DO NOT DRINK”
  - B. Non-potable water piping shall be designated by colored bands and solid color piping as specified by the authority having jurisdiction or national code agencies, and labeled:  

“NON POTABLE - RAINWATER”
  - C. Outlets and fixtures served with harvested rainwater shall be easily recognizable by color or a symbol for non-potable water.
- 3.6.5 Inspections. Rainwater harvesting systems are considered a private water system under the responsibility of the building owner / operator, and shall be minimally inspected according to the following schedule:
- A. Inspection of all elements before they are covered (rough-in inspection)
  - B. Final inspection including testing.
  - C. In addition to testing required by the code for plumbing systems, the following also apply:
    - 1. Testing and Commissioning
    - 2. Piping. A flow test shall be performed through the system to the point of water distribution and disposal. In addition, the water distribution system shall be tested and proved tight at the operating pressure. Where the manufacturer permits, a 50-psi hydrostatic test may substitute for the test above. All lines and components shall be watertight.
  - D. Other inspections as needed to assure proper system operation.
- 3.6.6 System Maintenance. It is the property owner's responsibility to maintain the system components according to manufacturer's written recommendations.
- 3.6.7 Rainwater harvesting systems shall be maintained in functioning order for the life of the system.
- A. Filtration and Disinfection systems shall be serviced in accordance with manufactures recommendations.
  - B. System Abandonment. If the owner of a rainwater harvesting system elects to cease use of, or fails to properly maintain such system, they shall abandon the system. To abandon the system, the system owner shall minimally:

## RAINWATER CATCHMENT DESIGN AND INSTALLATION STANDARDS

1. Remove or disable all system connecting piping to utility provided water system.
2. Replace the rainwater harvesting pipe system with an approved potable water supply pipe system. Where an existing potable pipe system is already in place, fixtures may be re-connected to the existing system.
3. Secure cistern from accidental access by sealing or locking tank inlets and access points, and / or filling with sand or equivalent.

### 3.7 POTABLE RAINWATER APPLICATIONS

3.7.1 Collection Surfaces for potable water applications shall be as noted in 3.1.1 above but shall also be made of non-toxic material.

- A. Painted surfaces are only acceptable if paint has been certified to ensure the toxicity level of the paint is acceptable for drinking water contact. Lead, chromium or zinc based paints are not permitted.
- B. Enameled Steel.
- C. Flat Roofs: Roof products shall be certified to NSF Protocol P151.
- D. Collection of water from vehicular parking surfaces is prohibited.

Not approved for potable water

- E. Wood / Cedar shake roofing.
- F. Copper roofing materials.
- G. Lead flashing is not approved for potable water.

Not Recommended for Potable Water or to be used with caution.

- H. Bitumen / Composition roofing.
- I. Galvanized, zinc-coated metal.

3.7.2 Cistern Inlets:

- A. Methodology of water entering cistern shall be to maintain a quiet flow A in the cistern by minimizing splashing and disturbance of sediment in bottom of cistern.
- B. For potable water applications, and recommended for maintaining good water quality, the pipe entering the cistern shall terminate in a return bend elbow pointed upward at the bottom of the tank, or equivalent calming device.



## RAINWATER CATCHMENT DESIGN AND INSTALLATION STANDARDS

- 3.7.3 Cistern outlets shall be provided with floating inlet to draw water from the cistern just below the water surface.
- A. Alternate: Cistern outlet to be located at least 4 inches above the bottom of the cistern.
- 3.7.4 Cisterns shall be intended for potable water use.
- A. Cisterns shall be certified for use with potable water with NSF, or recognized equivalent. Plastic tanks shall be constructed of virgin plastic and shall adhere to requirements of NSF / ANSI Standard 61.
  - B. Cisterns shall not be connected directly to a public or community water supply without approved back-flow protection. Make-up water to rainwater storage tanks, when provided, may be made through a reverse pressure principle back flow device or an air gap per local plumbing codes.
  - C. If installed below grade, cisterns shall be separated from sanitary waste piping a distance as recommended by local authority having jurisdiction, or local plumbing codes, and up gradient from septic field piping where applicable.
- 3.7.5 Filtration
- A. Carbon filtration may be provided for reduction of taste, odor and organic chemicals.
  - B. Filtration and Disinfection systems shall be located after water storage tank and as close to the final point of use as possible.
  - C. All particulate filtration shall be installed upstream of disinfection systems.
  - D. Filters shall be adequate size to extend service time and must be comply with NSF / ANSI Standard 53.
- 3.7.6 Water Disinfection
- A. Chlorination: Chlorination may be used with an automated demand feed system, and if used, shall enable adequate contact time and residual according to local health authorities.
  - B. Ozone: Ozone may be used with an approved ozone system ensuring adequate contact time with the ozone. Provision must be made to off- gas ozone to a safe environment.
  - C. Ultra-violet disinfection may be used and shall be provided between final filtration (5 micron maximum) and final point of use.

## RAINWATER CATCHMENT DESIGN AND INSTALLATION STANDARDS

### 3.7.7 Operation and Maintenance

- A. After several cycles of rain harvesting, an initial sample of the resultant accumulated water shall be tested for compliance according to procedures listed in the latest edition of Standard Methods for the Examination of Water and Wastewater (ALPHA).
- B. For a Private System, prior to placing the water system into service, water quality testing, at a minimum shall be performed for E. Coli, Total Coliform, and heterotrophic bacteria. Subsequent periodic testing to assess the ongoing integrity of this system is recommended.
- C. For a Public System (defined as a system where 25 different persons consume water from the system over a 60 day period): In addition to the above tests, water shall be tested for cryptosporidium. Subsequent annual tests shall be made for Total Coliform, E Coli, Heterotrophic bacteria and any chemicals of concern. . Records of test results shall be maintained for at least two (2) years.

## RAINWATER CATCHMENT DESIGN AND INSTALLATION STANDARDS

### 4.0 DEFINITIONS

In addition to definitions used in the Uniform and International Plumbing Codes, the following definitions apply to rainwater harvesting systems:

1. AUXILIARY SUPPLY: Water supply that is arranged and protected from contamination that is available to provide an alternate means of filling a cistern.
2. CALMING INLET: A device that permits water to enter a storage tank with minimal disturbance to particles that may have settled to bottom of the tank. See Quiescent Flow.
3. CISTERN : The central storage component of the rainwater harvesting system. Protection and maintenance of the cistern is essential for the health of the system.
4. CODE: Refers to the local written authority i.e. the Uniform Plumbing Code, International Plumbing Code, NSF International, etc.
5. COLLECTION AREA: Area from which rainwater is collected for use in a rainwater harvesting system (e.g. roof area).
6. DEBRIS EXCLUDER: A screen or other device installed on the gutter or down spout system to prevent the accumulation of leaves, needles, or other debris in the system.
7. DISINFECTION: Reduction of viable micro-organisms to a level that is deemed suitable for the intended application. Typical units of measure are Colony Forming Units per deca-liter (cfu / dl).
8. DRY RUN PROTECTION: System for protecting the water pump against running dry.
9. EVAPORATION FIELD: Element in the ground that is filled with gravel, ballast or special non-permeable plastic elements and that stores rainwater that is fed into it on an intermediate basis before the water evaporates into the atmosphere or seeps into the surrounding soil.
10. FILTRATION: Physical removal of liquid-borne contaminants by means of separation from the output flow. Particulate filtration removes suspended particles (measured in units of Total Suspended Solids (TSS)); while other forms of filtration, such as carbon / absorption filtration, removes dissolved compounds measured in units of Total Dissolved Solids (TDS).
11. GROUND WATER: Water that saturates into the ground and no longer flows across the surface, it is considered "Groundwater"

## RAINWATER CATCHMENT DESIGN AND INSTALLATION STANDARDS

12. FIRE SPRINKLER RESERVE: Volume of water needed for fire protection that is not available for any other use and accessible only by the fire pump
13. FLAT: Having a slope no greater than 1 in 50.
14. HARVESTED WATER: Process water system for utilizing rainwater for potable, non-potable, industrial or irrigation application.
15. LEACH FIELD, EVAPORATION / TRANSPIRATION FIELD: Element in the ground that is filled with gravel, ballast or special permeable plastic elements and that stores rainwater that is fed into it on an intermediate basis before the water seeps into the surrounding soil.
16. MINIMUM WATER VOLUME: Recoverable water volume that is constrained by the process such that neither sediment nor scum can be sucked into the deliverable water.
17. OVERFLOW LEVEL: The highest level that water from a drainage system can rise to.
18. OVERFLOW LINE: Line for leading away rainwater when the rainwater reservoir is full, e.g. into the sewage system or a seepage system
19. PIPING SYSTEM: Pipes that conveys the harvested rainwater and distributes it to various fixtures.
20. POINT OF USE: A point in a domestic water system, nearest to a water consuming plumbing fixture, where water is used.
21. PRECIPITATION: Water that has precipitated from the atmosphere (e.g. rain, snow, mist, dew)
22. PRECIPITATION CHARACTERISTICS: Characteristics of a precipitation event (e.g. intensity, duration)
23. PRIVATE WATER SYSTEM: System used by less than 25 persons over a 60 day period.
24. PROCESS WATER: Water to be used for household and commercial applications.
25. PROCESS WATER LINE: System of lines from the process water pump to the individual points at which water is drawn.
26. PROCESS WATER PUMP: Pumps process water from the rainwater reservoir to the points at which it is drawn.

## RAINWATER CATCHMENT DESIGN AND INSTALLATION STANDARDS

27. PROCESS WATER REQUIREMENTS: Planning value for the process water amount that is expected to be required in a specified period of time.
28. PUBLIC WATER SYSTEM: System that is used by 25 or more different persons over a 60 day period.
29. QUANTITY OF PRECIPITATION: Precipitation at a certain place, expressed as the water height over a horizontal area for a span of time under consideration .
30. QUIESCENT INFLOW: Routing of rainwater into rainwater reservoirs so that the existing sediment is not activated in the rainwater reservoir and an immediate sedimentation of solids is possible.
31. RAINWATER : Water from natural precipitation that was not contaminated by use.
32. RAINWATER HARVESTING SYSTEM: Water system for utilizing rainwater, consisting of a cistern(s), pipe, fittings, pumps and/or other plumbing appurtenances, required for and/or used to harvest and distribute rainwater.
33. RAINWATER LINE: Supply, drainage, overflow and emptying lines of a rainwater harvesting system.
34. RAINWATER YIELD: Net water volume (water inflow) ,determined over a certain period of time, available for use as process water. Typically this is approximately 80% of theoretical collectable rainwater.
35. RETURN ELBOW : A section of pipe with a 180-degree bend.
36. ROOF DRAINAGE SYSTEM: A system, comprised of roof drains, overflow drains, scuppers, gutters and down spouts, used to convey the rainwater from the roof surface to the roof washer and the cistern.
37. ROOF SURFACE : The surface rainwater harvesting systems rely on for the collection of rainwater that has fallen on a building roof.
38. ROOF WASH OR ROOF WASHER: A device or method for removal of sediment and debris from collection surface by diverting initial rainfall from entry into the cistern(s). Also called a First Flush Device
39. SCREEN: A filtration device, constructed of corrosion resistant wire or other approved mesh, having openings in determined sizes.
40. SEDIMENTATION: Separation of solids from the water via gravity.

## RAINWATER CATCHMENT DESIGN AND INSTALLATION STANDARDS

41. SLOPE OR SLOPING: Having a slope greater than 1 in 50.
42. SUB-SURFACE IRRIGATION: Water that is applied below ground level, and is not directly exposed to the above ground surface and/or surrounding air.
43. SUCTION LINE: Water pump inlet piping.
44. SUN BARRIERS : A cover, or erected structure, specifically to shelter a cistern from the direct rays of the sun.
45. SUPPLEMENTAL SUPPLY: Equipment for providing a supplemental supply of drinking water or non-drinking water into process water systems
46. SURFACE IRRIGATION: Water that is applied above ground level and is directly exposed to the above ground surface and/or air.
47. SURFACE WATER: Any rain water that touches the ground and flows across the surface of the ground (roadway, parking surface, gully, creeks, streams etc.) to be termed "surface water".
48. SYSTEM CONTROL UNIT: Control unit for the automatic operation of the rainwater harvesting system .
49. TRANSFER PUMP: A mechanical device to transfer collected water from down spouts to remote cisterns.
50. USEFUL VOLUME: Volume that can be completely used during operation (Typically .80 - .90 of storage volume).
51. YIELD COEFFICIENT: Ratio of the rainwater annually flowing into the rainwater harvesting system to the total amount of rainwater in the accompanying precipitation area , allowing for leakage, splashing, evaporation, etc. (Typically .75 - .90).

## RAINWATER CATCHMENT DESIGN AND INSTALLATION STANDARDS

### 5.0 ACCEPTABLE PIPING SCHEMATICS

Figure 1: Potable and / or Non-Potable Water

Figure shows an above ground application in a non-freeze environment. In an environment where freezing is possible, tank should be moved to a heated environment or buried below the frost line, as shown in the following details.

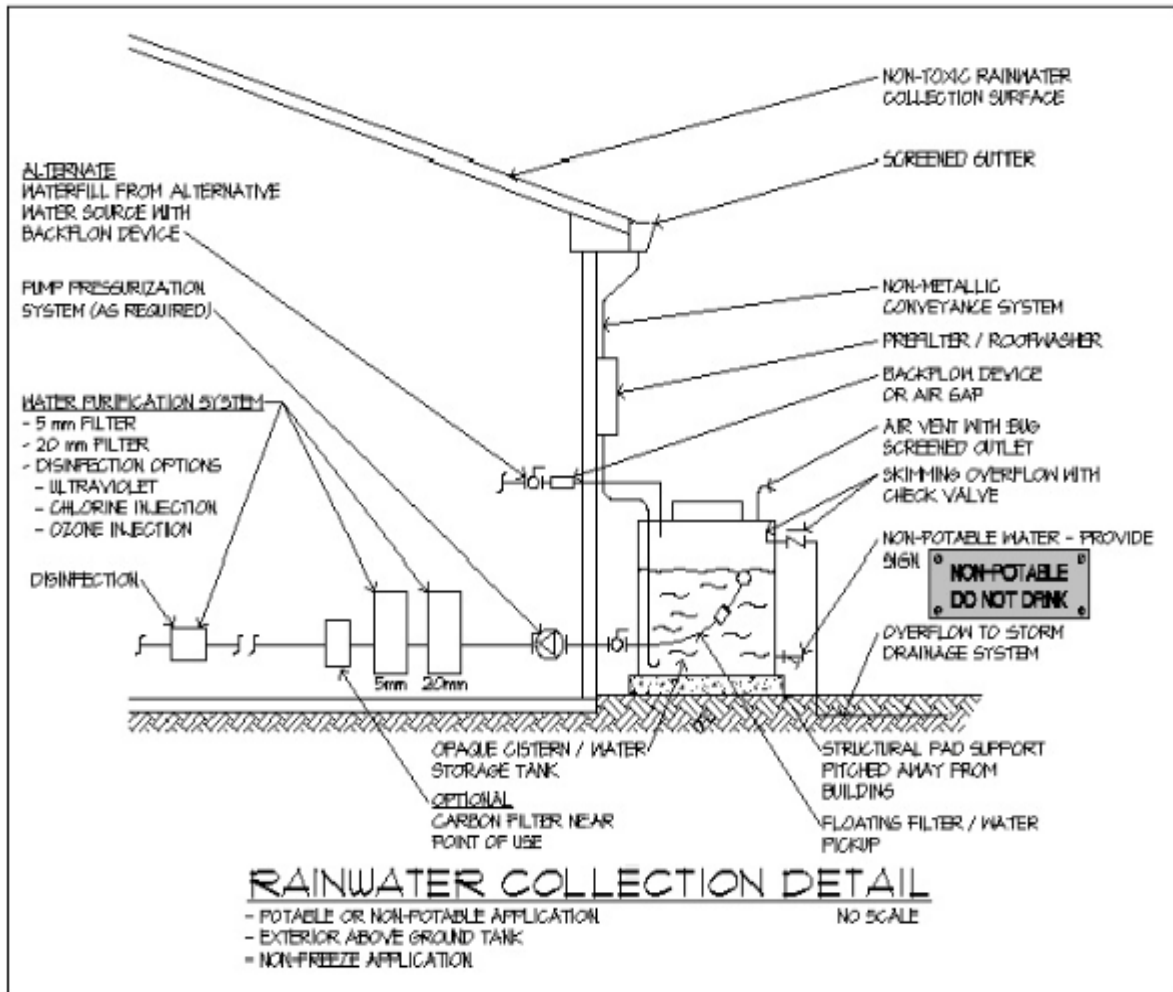

**Figure 1**

## RAINWATER CATCHMENT DESIGN AND INSTALLATION STANDARDS

Figure 2: Underground Exterior Cistern for Potable Application.

Where carbon filters are used, they may be put down stream of chlorine and ozone disinfection systems, but are recommended to be upstream of Ultraviolet disinfection systems. Where soil saturation is a possibility, it is recommended that the combined weight of the tank and ballast must meet or exceed the buoyancy upward force of an empty cistern. This buoyance force (lbs.) is equal to the volume of the tank (cubic feet) x 62.4 lbs / cubic feet, or tank volume ( gallons) x 8.34 lbs / gallon water

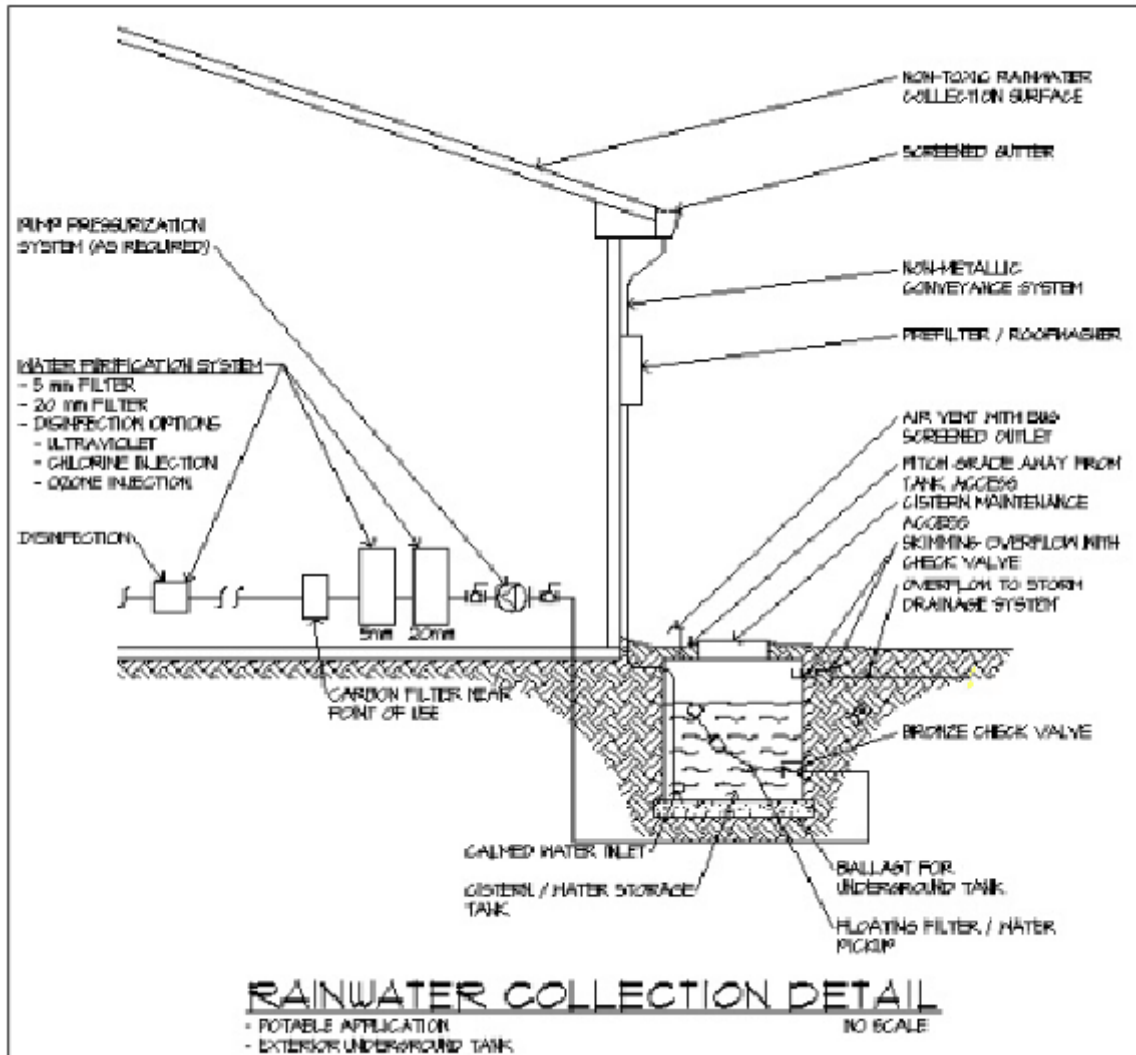

Figure 2



## RAINWATER CATCHMENT DESIGN AND INSTALLATION STANDARDS

**Figure 3: Non-Potable Water**

This application is suitable for lawn and plant irrigation or process water makeup. Filters to remove particulate may be added to improve water quality in order to avoid problems with sprinkler or process devices.

Signage marking water outlets as “ Non-Potable, Do Not Drink “ are required in a public environment and highly recommended elsewhere.

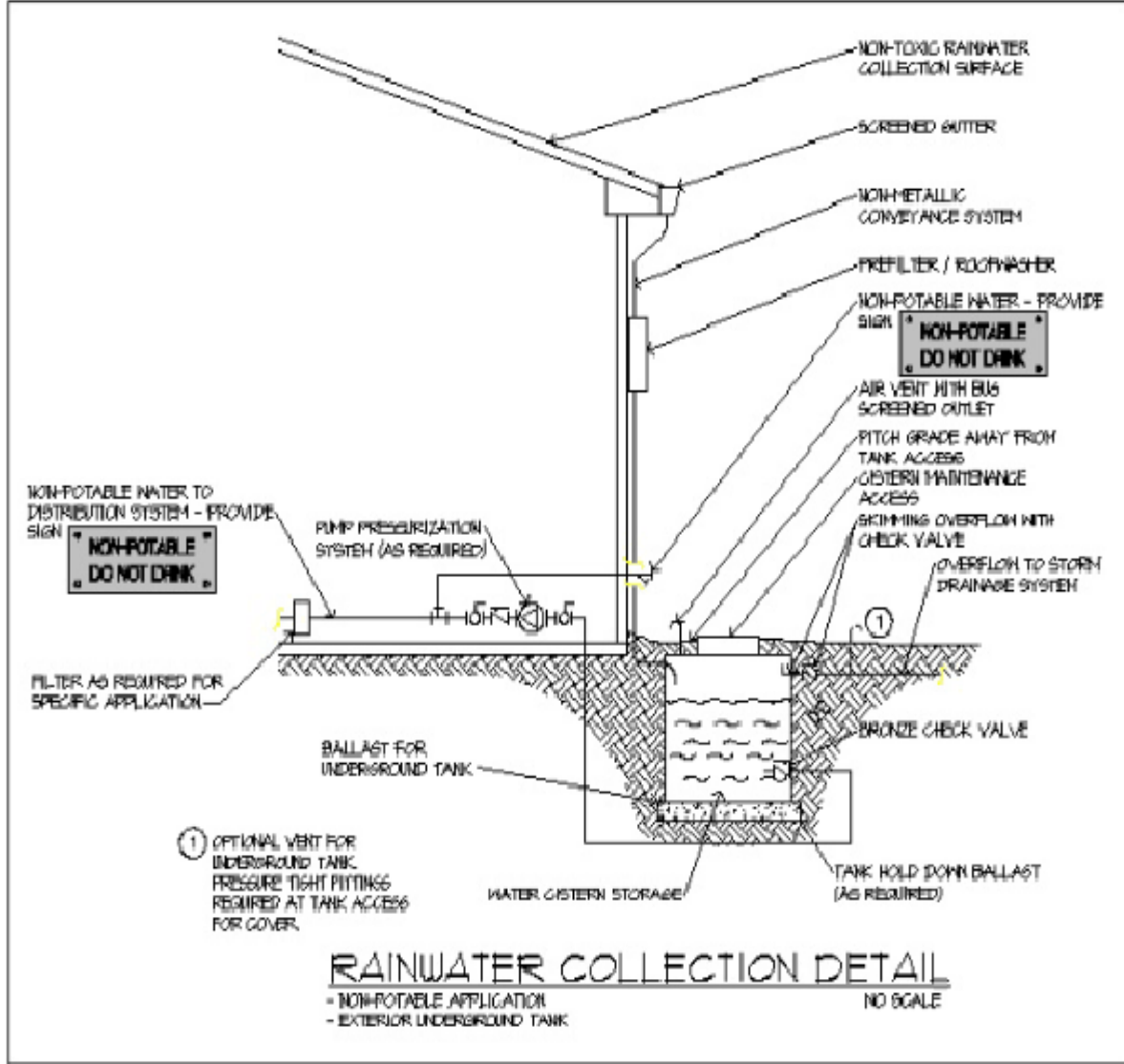

**Figure 3.**

## RAINWATER CATCHMENT DESIGN AND INSTALLATION STANDARDS

Figure 4: Potable and Non-Potable Water

Installing a water storage tank in a heated environment is preferred for an installation subject to freezing. Appropriate signage is necessary to label non-potable water outlets.

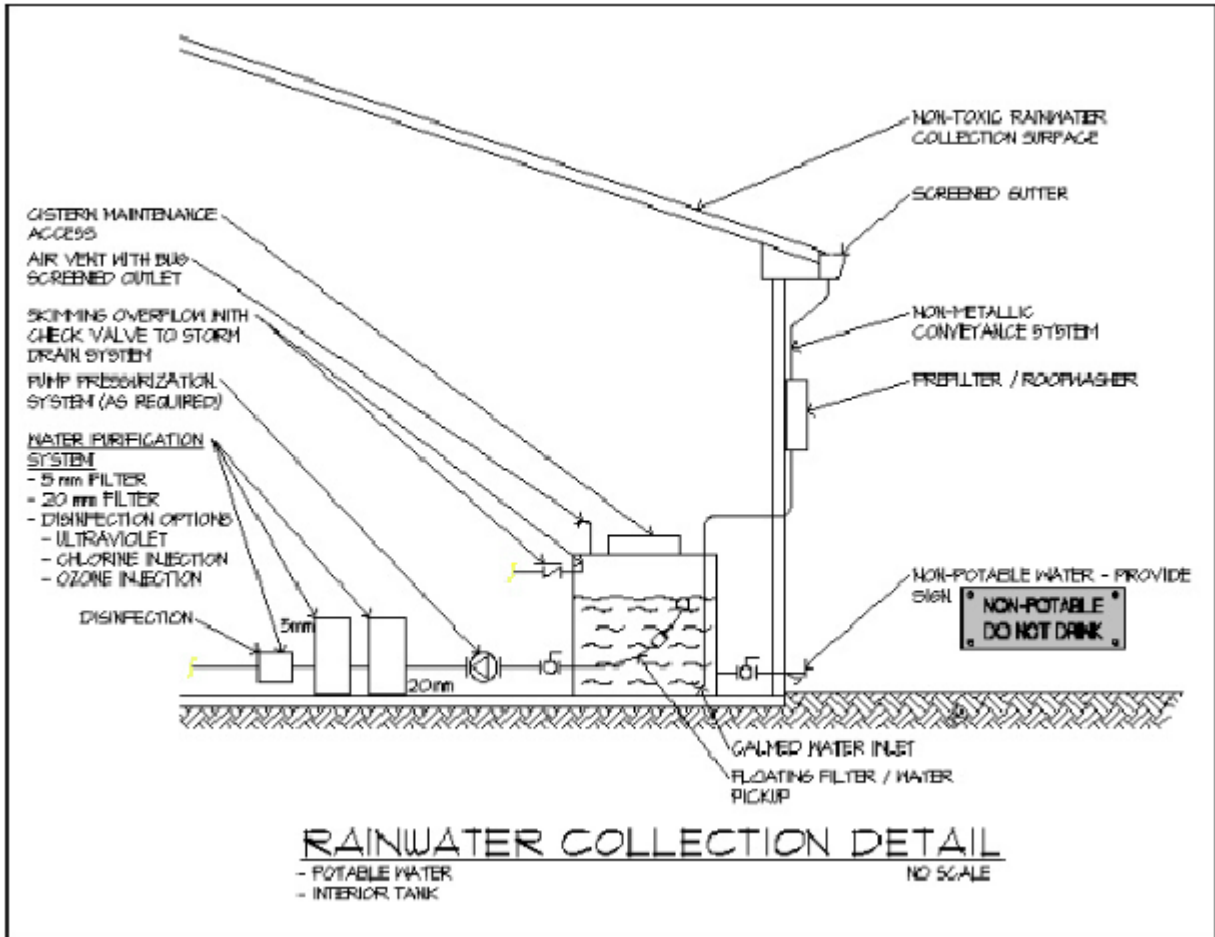

Figure 4.

## RAINWATER CATCHMENT DESIGN AND INSTALLATION STANDARDS

### 5.1 ROOF WASHER

Roof Washers are commonly used to waste the initial water coming off the collection surface before being allowed to fill the cistern. Commonly used roof wash amounts are indicated below, but may be varied to reflect actual site and seasonal conditions.

<u>Estimated Roof Contamination Potential</u>		
<u>High Contamination</u> <sup>1</sup>	<u>Medium Contamination</u>	<u>Low Contamination</u> <sup>2</sup>
.03" / 8mm	.01" / 2 mm	.002" / .5mm
Notes:		
(1) High Contamination is considered to have high content of organic debris from animal waste, adjacent trees, and / or airborne contamination.		
(2) Low Contamination is considered to either have frequent rainfall to keep collection surface clean, and / or minimal non toxic contamination.		
(3) Sample Calculation: 1000 square foot collection surface, medium contamination:		
Gallons = .01" rain x 1000 Square Feet x .623 gallons / square foot - inch:		
= 6.23 gallons		
<b>Figure 5.</b>		

## RAINWATER CATCHMENT DESIGN AND INSTALLATION STANDARDS

There are many different styles of roof wash devices. The simplest versions involve filling a stand pipe section of piping that contains adequate volume, that once full, then overflows into the cistern. ( See Figure 6). A short coming of this concept is that it allows mixing from the contaminated pre-wash volume and the water to be saved in the cistern.

Another commercially available first flush diverter (See Figure 7.) attempts to address the mixing issue by using a stand pipe and floating ball. Once the standpipe is filled with the pre-wash water, a floating ball seals off the remaining flow preventing the pre-wash water from being mixed with the remaining flow. The remaining rainfall is then diverted to the cistern. This device has a drain at the bottom that allows diverted water to slowly drain after each rainfall event and a clean-out plug to clean out any accumulated debris.

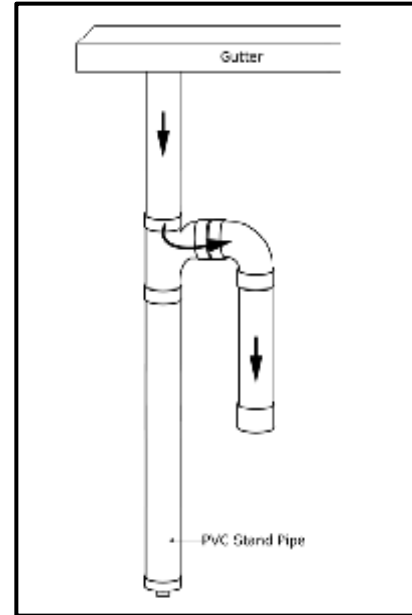

Figure 6.

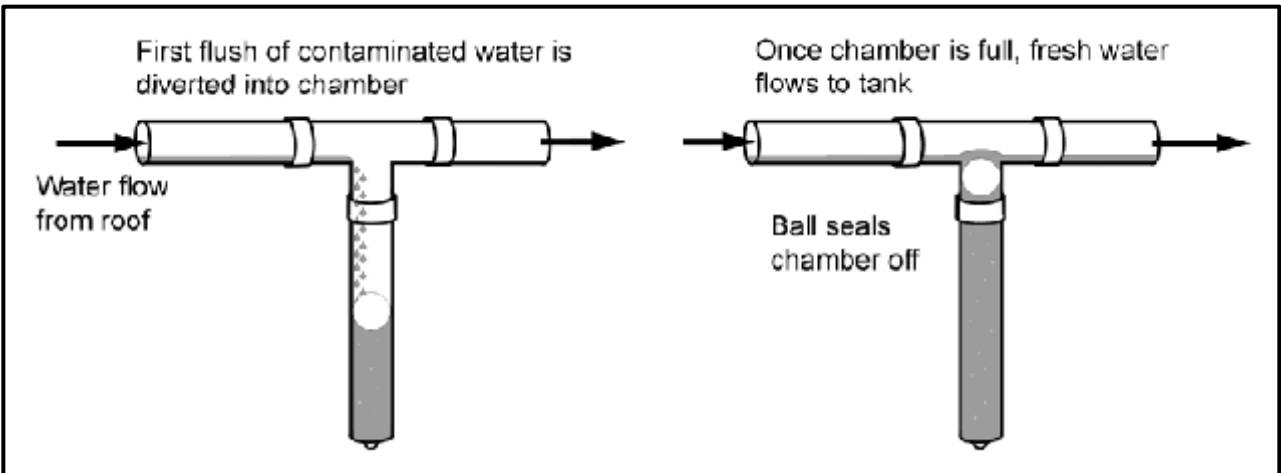

Figure 7.

Other commercially available combination pre-filter and roof wash devices are available to help maintain the water quality of the rainwater harvesting system.

## RAINWATER CATCHMENT DESIGN AND INSTALLATION STANDARDS

The volume of pre-wash for a nominal 4" (4.046 inch actual) diameter PVC pipe can be determined as follows in Figure 8a.

<b>4" PVC Pipe Storage Volume</b>	
<u>Length : feet (meters)</u>	<u>Volume: gallons (liters)</u>
1 (.3)	.7 (2.6)
3 (.9)	2.0 (7.6)
5 (4.6)	3.3 (12.5)
10 (3.0)	6.7 (25.4)
15 (4.6)	15.0 (56.8)

**Figure 8a.**

The volume of pre-wash for a nominal 6" (6.065 inch actual) diameter PVC pipe can be seen in Figure 8b.

### **6" PVC Pipe Storage Volume**

<u>Length : feet (meters)</u>	<u>Volume: gallons (liters)</u>
1 (.3)	1.5 (5.7)
3 (.9)	4.5 (17.0)
5 (4.6)	7.5 (28.4)
10 (3.0)	15.0 (56.8)
15 (4.6)	22.5 (85.2)

**Figure 8b.**

Maintenance Worksheet for \_\_\_\_\_

	Change UV light	Change of Rinse Filters	Test For Bacteria	Clean First Flush	Check for leaks	Test for Giardia/Cryptosporidium
Frequency:	Annually	Quarterly or as needed	Quarterly	Quarterly or after each rain	After Each Rain or Quarterly	initially and as required
Date Done						
Date Done						
Date Done						
Date Done						

Date	Meter Reading	Date	Meter Reading	Date	Meter Reading	Date	Meter Reading

Installer: name; Phone \_\_\_\_\_  
 Test Water: \_\_\_\_\_ Health Department; address/phone \_\_\_\_\_ (retain all records)  
 Order UV Light From (Size): \_\_\_\_\_  
 Order Filters (Size and Specs) \_\_\_\_\_ From \_\_\_\_\_

## RAINWATER CATCHMENT DESIGN AND INSTALLATION STANDARDS

### Calculation Procedure

#### Step 1: Estimate demand:

Interior Water Requirement\*: On average, a conserving American household uses 45.2 gallons per person/day to operate toilets, showers, clothes washers, sinks, and other water -using fixtures and appliances. Water demand can be minimized by using water efficient water fixtures. An example of how to estimate water demand is shown as follows:

#### Residential Indoor Water Use

Fixture	Flow Rate (per use or min) **	Average # uses/day or min/day per person	Daily Demand / person (gal)	Number of people in household	Household Total Daily Demand/ (gal)	Household Total Monthly demand (gal)	Household Total Yearly demand (gal)
Toilets	1.6	5.1	8.16	3	24.48	742	8,935
Shower (based on 2.5 gal/min)	1.66	5.3	8.80	3	26.39	800	9,634
Faucets (based on 2.5 gal/min)	1.66	8.1	13.45	3	40.34	1,222	14,723
Dishwasher (1997- 2001) (gal/use)	4.5	0.1	0.45	3	1.35	41	493
Clothes washer (1998 - 2001) (gal/use)	27	0.37	9.99	3	29.97	908	10,939
<b>Total Demand</b>					<b>122.5</b>	<b>3,713</b>	<b>44,724</b>

\*Source: "Handbook of Water Use and Conservation" Amy Vickers, 2001, Waterplow Press, Amherst, MA, ISBN I-931579-07-5

\*\* Actual Flow (MFR)

## RAINWATER CATCHMENT DESIGN AND INSTALLATION STANDARDS

Irrigation Water Requirement: Water used to irrigate landscaping often equals or exceeds interior water use. Supplemental irrigation water requirements can be greatly reduced by the use of 3 inches or more of top mulch, selecting native plants or plants that thrive in regions with similar climate, and using passive rainwater techniques. Because plant water needs vary greatly depending on soils, climate, plant size, etc. it is recommended that a calculator for your region be referenced. For calculators, visit the ARCSA website at: [www.arcsa.org](http://www.arcsa.org).

### Step 2: Sizing the Collection System

The collection surface is often dictated by architectural constraints, such as roof area, etc. The amount of surface area, based on the needed water volume, is described as follows:

Surface Area (Square Feet) = Demand (Gallons) / 0.623 x Precipitation Density (inches) x system efficiency

Note:

- 0.623 (gallons / square foot / inch) conversion factor = 7.48 (gallons / cubic foot) / 12 (inches per foot). 1 inch of water covering 1 square foot of surface area = 0.623 gallons
- Surface area is horizontal projection of roof surface and not actual surface area (measure the area the roof covers, not the actual roof).
- Precipitation Density period consistent with time period being considered ( monthly, yearly, etc)
- This coefficient accounts for collection system loss from leakage, evaporation, roof composition, etc. Roof coefficients are approximately 0.90

### Step 3: Sizing the Storage<sup>1</sup>

Once the area of roof catchment has been determined and the average rainfall has been established the maximum amount of rain that can be collected can be calculated using the formula:

$$\text{Run-off (Gallons)} = A \times (\text{Rainfall} - B) \times \text{Roof Area}$$

**A** is the efficiency of collection and values of 0.80-0.85 (i.e. 80-85% efficiency) have been used.

**B** is the loss associated with adsorption and wetting of surfaces and a value of .08 inches per month (2.0 inches per year) has been used (eg Martin, 1980).

**Rainfall** should be expressed in Inches and **Roof Area** in Square Feet

---

<sup>1</sup>Adapted from Martin, T.J. (1980). *Supply aspects of domestic rainwater tanks*. South Australian Department of Environment, Adelaide.



## RAINWATER CATCHMENT DESIGN AND INSTALLATION STANDARDS

The maximum volumes of rainwater that can be collected from various areas of roof and at a range of average annual rainfalls are shown in Appendix III. This information should only be used as an initial guide. If the maximum volumes are less than the annual water demand then either the catchment area will need to be increased or water demand will need to be reduced.

The next step is to calculate the size of the tank. The tank needs to be large enough to ensure that:

1. The required volume of water can be collected by the tank.
2. The volume of water in the tank will be sufficient to meet demand during the drier months or through periods of low or no rainfall.

The simplest way of checking a tank size estimated to provide water throughout an average year is to use monthly rainfall data and to assume that at the start of the wetter months the tank is empty. The following formula should then be used for each month:

$$Vt = V t-1 + (\text{Run-off} - \text{Demand})$$

$Vt$  = theoretical volume of water remaining in the tank at the end of the month

$V t-1$  = volume of water left in the tank from the previous month.

**Run-off** should be calculated as discussed above ( $A = 0.80$ ,  $B = .08$  inches).

Starting with the tank empty then  $Vt-1 = 0$ . If after any month  $Vt$  exceeds the volume of the tank then water will be lost to overflow. If  $Vt$  is ever a negative figure then demand exceeds the available water. Providing the calculated annual run-off exceeds the annual water demand,  $Vt$  will only be negative if periodical overflows reduce the amount of water collected so that it is less than the demand.

Tank size is not necessarily based on collecting total roof run-off. For example, the maximum water that can be collected from a roof area of 20 square feet with an monthly rainfall of 4.0 inches, will be about 40 gallons.

If the water demand is less than this, some overflow may occur while demand is still met. If water demand is to be met throughout the month, the tank should be large enough so that  $Vt$  is never negative.

Calculations should be repeated using various tank sizes until  $Vt$  is 0 at the end of every month. The greater the values of  $Vt$  over the whole year, the greater the security of meeting water demand when rainfalls are below average or when dry periods are longer than normal.

*The greater the security, the higher the cost of the tank.*

### Step 4: System Adjustment

To optimize performance and cost, going back through the calculation modifying surface area and the cistern storage capacity is recommended.

RAINWATER CATCHMENT DESIGN AND INSTALLATION STANDARDS

<b>NORMALS 1971-2000</b>	<b>YRS</b>	<b>JAN</b>	<b>FEB</b>	<b>MAR</b>	<b>APR</b>	<b>MAY</b>	<b>JUN</b>	<b>JUL</b>	<b>AUG</b>	<b>SEP</b>	<b>OCT</b>	<b>NOV</b>	<b>DEC</b>	<b>ANN</b>
BIRMINGHAM AP,AL	30	5.45	4.21	6.10	4.67	4.83	3.78	5.09	3.48	4.05	3.23	4.63	4.47	53.99
HUNTSVILLE, AL	30	5.52	4.95	6.68	4.54	5.24	4.22	4.40	3.32	4.29	3.54	5.22	5.59	57.51
MOBILE, AL	30	5.75	5.10	7.20	5.06	6.10	5.01	6.54	6.20	6.01	3.25	5.41	4.66	66.29
MONTGOMERY, AL	30	5.04	5.45	6.39	4.38	4.14	4.13	5.31	3.63	4.22	2.58	4.53	4.97	54.77
ANCHORAGE, AK	30	0.68	0.74	0.65	0.52	0.70	1.06	1.70	2.93	2.87	2.09	1.09	1.05	16.08
ANNETTE, AK	30	9.67	8.05	7.96	7.37	5.73	4.72	4.26	6.12	9.49	13.86	12.21	11.39	100.83
BARROW, AK	30	0.12	0.12	0.09	0.12	0.12	0.32	0.87	1.04	0.69	0.39	0.16	0.12	4.16
BETHEL, AK	30	0.62	0.51	0.67	0.65	0.85	1.60	2.03	3.02	2.31	1.43	1.37	1.12	16.18
BETTLES,AK	30	0.84	0.61	0.55	0.38	0.85	1.43	2.10	2.54	1.82	1.08	0.90	0.87	13.97
BIG DELTA,AK	30	0.34	0.41	0.22	0.20	0.77	2.38	2.77	2.11	1.03	0.73	0.59	0.39	11.94
COLD BAY,AK	30	3.08	2.59	2.48	2.30	2.65	2.89	2.53	3.59	4.51	4.54	4.79	4.33	40.28
FAIRBANKS, AK	30	0.56	0.36	0.28	0.21	0.60	1.40	1.73	1.74	1.12	0.92	0.68	0.74	10.34
GULKANA,AK	30	0.45	0.52	0.36	0.22	0.59	1.54	1.82	1.80	1.44	1.02	0.67	0.97	11.40
HOMER, AK	30	2.61	2.04	1.82	1.21	1.07	0.96	1.45	2.28	3.37	2.77	2.87	3.00	25.45
JUNEAU, AK	30	4.81	4.02	3.51	2.96	3.48	3.36	4.14	5.37	7.54	8.30	5.43	5.41	58.33
KING SALMON, AK	30	1.03	0.72	0.79	0.94	1.35	1.70	2.15	2.89	2.81	2.10	1.54	1.39	19.41
KODIAK, AK	30	8.17	5.72	5.22	5.48	6.31	5.38	4.12	4.48	7.84	8.36	6.63	7.64	75.35
KOTZEBUE, AK	30	0.55	0.42	0.38	0.41	0.33	0.57	1.43	2.00	1.70	0.95	0.71	0.60	10.05
MCGRATH, AK	30	1.04	0.74	0.81	0.66	1.02	1.45	2.32	2.75	2.36	1.46	1.46	1.44	17.51
NOME, AK	30	0.92	0.75	0.60	0.65	0.74	1.14	2.15	3.23	2.51	1.58	1.28	1.01	16.56
ST. PAUL ISLAND, AK	30	1.74	1.25	1.12	1.12	1.21	1.41	1.91	2.96	2.79	2.70	2.87	2.13	23.21
TALKEETNA, AK	30	1.45	1.28	1.26	1.22	1.64	2.41	3.24	4.53	4.35	3.06	1.78	1.96	28.18
UNALAKLEET, AK	30	0.40	0.31	0.39	0.35	0.55	1.25	2.15	2.92	2.10	0.89	0.66	0.47	12.44
VALDEZ, AK	30	6.02	5.53	4.49	3.55	3.08	3.01	3.84	6.62	9.59	8.58	5.51	7.59	67.41
YAKUTAT, AK	30	13.18	10.99	11.41	10.80	9.78	7.17	7.88	13.27	20.88	24.00	15.17	15.85	160.38
FLAGSTAFF, AZ	30	2.18	2.56	2.62	1.29	0.80	0.43	2.40	2.89	2.12	1.93	1.86	1.83	22.91
PHOENIX, AZ	30	0.83	0.77	1.07	0.25	0.16	0.09	0.99	0.94	0.75	0.79	0.73	0.92	8.29
TUCSON, AZ	30	0.99	0.88	0.81	0.28	0.24	0.24	2.07	2.30	1.45	1.21	0.67	1.03	12.17
WINSLOW, AZ	30	0.46	0.53	0.61	0.27	0.36	0.30	1.18	1.31	1.02	0.90	0.55	0.54	8.03
YUMA, AZ	30	0.38	0.28	0.27	0.09	0.05	0.02	0.23	0.61	0.26	0.26	0.14	0.42	3.01
FORT SMITH, AR	30	2.37	2.59	3.94	3.91	5.29	4.28	3.19	2.56	3.61	3.94	4.80	3.39	43.87
LITTLE ROCK, AR	30	3.61	3.33	4.88	5.47	5.05	3.95	3.31	2.93	3.71	4.25	5.73	4.71	50.93
NORTH LITTLE ROCK, AR	30	3.37	3.27	4.88	5.03	5.40	3.51	3.15	2.97	3.53	3.81	5.74	4.53	49.19
BAKERSFIELD, CA	30	1.18	1.21	1.41	0.45	0.24	0.12	0.00	0.08	0.15	0.30	0.59	0.76	6.49
BISHOP, CA	30	0.88	0.97	0.62	0.24	0.26	0.21	0.17	0.13	0.28	0.20	0.44	0.62	5.02
EUREKA, CA.	30	5.97	5.51	5.55	2.91	1.62	0.65	0.16	0.38	0.86	2.36	5.78	6.35	38.10
FRESNO, CA	30	2.16	2.12	2.20	0.76	0.39	0.23	0.01	0.01	0.26	0.65	1.10	1.34	11.23
LONG BEACH, CA	30	2.95	3.01	2.43	0.60	0.23	0.08	0.02	0.10	0.24	0.40	1.12	1.76	12.94
LOS ANGELES AP, CA	30	2.98	3.11	2.40	0.63	0.24	0.08	0.03	0.14	0.26	0.36	1.13	1.79	13.15
LOS ANGELES C.O., CA	30	3.33	3.68	3.14	0.83	0.31	0.06	0.01	0.13	0.32	0.37	1.05	1.91	15.14
MOUNT SHASTA, CA	30	7.06	6.45	5.81	2.65	1.87	0.99	0.39	0.43	0.87	2.21	5.08	5.35	39.16
REDDING, CA	30	6.50	5.49	5.15	2.40	1.66	0.69	0.05	0.22	0.48	2.18	4.03	4.67	33.52
SACRAMENTO, CA	30	3.84	3.54	2.80	1.02	0.53	0.20	0.05	0.06	0.36	0.89	2.19	2.45	17.93
SAN DIEGO, CA	30	2.28	2.04	2.26	0.75	0.20	0.09	0.03	0.09	0.21	0.44	1.07	1.31	10.77
SAN FRANCISCO AP, CA	30	4.45	4.01	3.26	1.18	0.38	0.11	0.03	0.07	0.20	1.04	2.49	2.89	20.11

**RAINWATER CATCHMENT DESIGN AND INSTALLATION STANDARDS**

<b>NORMALS 1971-2000</b>	<b>YRS</b>	<b>JAN</b>	<b>FEB</b>	<b>MAR</b>	<b>APR</b>	<b>MAY</b>	<b>JUN</b>	<b>JUL</b>	<b>AUG</b>	<b>SEP</b>	<b>OCT</b>	<b>NOV</b>	<b>DEC</b>	<b>ANN</b>
SAN FRANCISCO C.O., CA	30	4.72	4.15	3.40	1.25	0.54	0.13	0.04	0.09	0.28	1.19	3.31	3.18	22.28
SANTA BARBARA, CA	30	3.57	4.28	3.51	0.63	0.23	0.05	0.03	0.11	0.42	0.52	1.32	2.26	16.93
SANTA MARIA, CA	30	2.64	3.23	2.94	0.91	0.32	0.05	0.03	0.05	0.31	0.45	1.24	1.84	14.01
STOCKTON, CA	30	2.71	2.46	2.28	0.96	0.50	0.09	0.05	0.05	0.33	0.82	1.77	1.82	13.84
ALAMOSA, CO	30	0.25	0.21	0.46	0.54	0.70	0.59	0.94	1.19	0.89	0.67	0.48	0.33	7.25
COLORADO SPRINGS, CO	30	0.28	0.35	1.06	1.62	2.39	2.34	2.85	3.48	1.23	0.86	0.52	0.42	17.40
DENVER, CO	30	0.51	0.49	1.28	1.93	2.32	1.56	2.16	1.82	1.14	0.99	0.98	0.63	15.81
GRAND JUNCTION, CO	30	0.60	0.50	1.00	0.86	0.98	0.41	0.66	0.84	0.91	1.00	0.71	0.52	8.99
PUEBLO, CO	30	0.33	0.26	0.97	1.25	1.49	1.33	2.04	2.27	0.84	0.64	0.58	0.39	12.39
BRIDGEPORT, CT	30	3.73	2.92	4.15	3.99	4.03	3.57	3.77	3.75	3.58	3.54	3.65	3.47	44.15
HARTFORD, CT	30	3.84	2.96	3.88	3.86	4.39	3.85	3.67	3.98	4.13	3.94	4.06	3.60	46.16
WILMINGTON, DE	30	3.43	2.81	3.97	3.39	4.15	3.59	4.28	3.51	4.01	3.08	3.19	3.40	42.81
WASHINGTON DULLES AP, D.C		3.05	2.77	3.55	3.22	4.22	4.07	3.57	3.78	3.82	3.37	3.31	3.07	41.80
WASHINGTON NAT'L AP, D.C.	30	3.21	2.63	3.60	2.77	3.82	3.13	3.66	3.44	3.79	3.22	3.03	3.05	39.35
APALACHICOLA, FL	30	4.87	3.76	4.95	3.00	2.62	4.30	7.31	7.29	7.10	4.18	3.62	3.51	56.51
DAYTONA BEACH, FL	30	3.13	2.74	3.84	2.54	3.26	5.69	5.17	6.09	6.61	4.48	3.03	2.71	49.29
FORT MYERS, FL	30	2.23	2.10	2.74	1.67	3.42	9.77	8.98	9.54	7.86	2.59	1.71	1.58	54.19
GAINESVILLE, FL	30	3.51	3.39	4.26	2.86	3.23	6.78	6.10	6.63	4.37	2.50	2.17	2.56	48.36
JACKSONVILLE, FL	30	3.69	3.15	3.93	3.14	3.48	5.37	5.97	6.87	7.90	3.86	2.34	2.64	52.34
KEY WEST, FL	30	2.22	1.51	1.86	2.06	3.48	4.57	3.27	5.40	5.45	4.34	2.64	2.14	38.94
MIAMI, FL	30	1.88	2.07	2.56	3.36	5.52	8.54	5.79	8.63	8.38	6.19	3.43	2.18	58.53
ORLANDO, FL	30	2.43	2.35	3.54	2.42	3.74	7.35	7.15	6.25	5.76	2.73	2.32	2.31	48.35
PENSACOLA, FL	30	5.34	4.68	6.40	3.89	4.40	6.39	8.02	6.85	5.75	4.13	4.46	3.97	64.28
TALLAHASSEE, FL	30	5.36	4.63	6.47	3.59	4.95	6.92	8.04	7.03	5.01	3.25	3.86	4.10	63.21
TAMPA, FL	30	2.27	2.67	2.84	1.80	2.85	5.50	6.49	7.60	6.54	2.29	1.62	2.30	44.77
VERO BEACH, FL	30	2.89	2.45	4.20	2.88	3.80	6.03	6.53	6.04	6.84	5.04	3.04	2.19	51.93
WEST PALM BEACH, FL	30	3.75	2.55	3.68	3.57	5.39	7.58	5.97	6.65	8.10	5.46	5.55	3.14	61.39
ATHENS, GA	30	4.69	4.39	4.99	3.35	3.86	3.94	4.41	3.78	3.53	3.47	3.71	3.71	47.83
ATLANTA, GA	30	5.03	4.68	5.38	3.62	3.95	3.63	5.12	3.67	4.09	3.11	4.10	3.82	50.20
AUGUSTA, GA	30	4.50	4.11	4.61	2.94	3.07	4.19	4.07	4.48	3.59	3.20	2.68	3.14	44.58
COLUMBUS, GA	30	4.78	4.48	5.75	3.84	3.62	3.51	5.04	3.78	3.07	2.33	3.97	4.40	48.57
MACON, GA	30	5.00	4.55	4.90	3.14	2.98	3.54	4.32	3.79	3.26	2.37	3.22	3.93	45.00
SAVANNAH, GA	30	3.95	2.92	3.64	3.32	3.61	5.49	6.04	7.20	5.08	3.12	2.40	2.81	49.58
HILO, HI	30	9.74	8.86	14.35	12.54	8.07	7.36	10.71	9.78	9.14	9.64	15.58	10.50	126.27
HONOLULU, HI	30	2.73	2.35	1.89	1.11	0.78	0.43	0.50	0.46	0.74	2.18	2.27	2.85	18.29
KAHULUI, HI	30	3.74	2.36	2.35	1.75	0.66	0.23	0.49	0.53	0.39	1.05	2.17	3.08	18.80
LIHUE, HI	30	4.59	3.26	3.58	3.00	2.87	1.82	2.12	1.91	2.69	4.25	4.70	4.78	39.57
BOISE, ID	30	1.39	1.14	1.41	1.27	1.27	0.74	0.39	0.30	0.76	0.76	1.38	1.38	12.19
LEWISTON, ID	30	1.14	0.95	1.12	1.31	1.56	1.16	0.72	0.75	0.81	0.96	1.21	1.05	12.74
POCATELLO, ID	30	1.14	1.01	1.38	1.18	1.51	0.91	0.70	0.66	0.89	0.97	1.13	1.10	12.58
CHICAGO, IL	30	1.75	1.63	2.65	3.68	3.38	3.63	3.51	4.62	3.27	2.71	3.01	2.43	36.27
MOLINE, IL	30	1.58	1.51	2.92	3.82	4.25	4.63	4.03	4.41	3.16	2.80	2.73	2.20	38.04
PEORIA, IL	30	1.50	1.67	2.83	3.56	4.17	3.84	4.02	3.16	3.12	2.77	2.99	2.40	36.03
ROCKFORD, IL	30	1.41	1.34	2.39	3.62	4.03	4.80	4.10	4.21	3.47	2.57	2.63	2.06	36.63
SPRINGFIELD, IL	30	1.62	1.80	3.15	3.36	4.06	3.77	3.53	3.41	2.83	2.62	2.87	2.54	35.56
EVANSVILLE, IN	30	2.91	3.10	4.29	4.48	5.01	4.10	3.75	3.14	2.99	2.78	4.18	3.54	44.27
FORT WAYNE, IN	30	2.05	1.94	2.86	3.54	3.75	4.04	3.58	3.60	2.81	2.63	2.98	2.77	36.55
INDIANAPOLIS, IN	30	2.48	2.41	3.44	3.61	4.36	4.13	4.42	3.82	2.88	2.76	3.61	3.03	40.95
SOUTH BEND, IN	30	2.27	1.98	2.89	3.62	3.50	4.19	3.73	3.98	3.79	3.27	3.39	3.09	39.70
DES MOINES, IA	30	1.03	1.19	2.21	3.58	4.25	4.57	4.18	4.51	3.15	2.62	2.10	1.33	34.72

**RAINWATER CATCHMENT DESIGN AND INSTALLATION STANDARDS**

<b>NORMALS 1971-2000</b>	<b>YRS</b>	<b>JAN</b>	<b>FEB</b>	<b>MAR</b>	<b>APR</b>	<b>MAY</b>	<b>JUN</b>	<b>JUL</b>	<b>AUG</b>	<b>SEP</b>	<b>OCT</b>	<b>NOV</b>	<b>DEC</b>	<b>ANN</b>
DUBUQUE, IA	30	1.28	1.42	2.57	3.49	4.12	4.08	3.73	4.59	3.56	2.50	2.49	1.69	35.52
SIOUX CITY, IA	30	0.59	0.62	2.00	2.75	3.75	3.61	3.30	2.90	2.42	1.99	1.40	0.66	25.99
WATERLOO, IA	30	0.84	1.05	2.13	3.23	4.15	4.82	4.20	4.08	2.95	2.49	2.10	1.11	33.15
CONCORDIA, KS	30	0.66	0.73	2.35	2.45	4.20	3.95	4.20	3.24	2.50	1.84	1.45	0.86	28.43
DODGE CITY, KS	30	0.62	0.66	1.84	2.25	3.00	3.15	3.17	2.73	1.70	1.45	1.01	0.77	22.35
GOODLAND, KS	30	0.43	0.44	1.20	1.51	3.46	3.30	3.54	2.49	1.12	1.05	0.82	0.40	19.76
TOPEKA, KS	30	0.95	1.18	2.56	3.14	4.86	4.88	3.83	3.81	3.71	2.99	2.31	1.42	35.64
WICHITA, KS	30	0.84	1.02	2.71	2.57	4.16	4.25	3.31	2.94	2.96	2.45	1.82	1.35	30.38
GREATER CINCINNATI AP	30	2.92	2.75	3.90	3.96	4.59	4.42	3.75	3.79	2.82	2.96	3.46	3.28	42.60
JACKSON, KY	30	3.56	3.68	4.38	3.79	5.16	4.67	4.59	4.13	3.77	3.18	4.20	4.27	49.38
LEXINGTON, KY	30	3.34	3.27	4.41	3.67	4.78	4.58	4.81	3.77	3.11	2.70	3.44	4.03	45.91
LOUISVILLE, KY	30	3.28	3.25	4.41	3.91	4.88	3.76	4.30	3.41	3.05	2.79	3.81	3.69	44.54
PADUCAH KY	30	3.47	3.93	4.27	4.95	4.75	4.51	4.45	2.99	3.56	3.45	4.53	4.38	49.24
BATON ROUGE, LA	30	6.19	5.10	5.07	5.56	5.34	5.33	5.96	5.86	4.84	3.81	4.76	5.26	63.08
LAKE CHARLES, LA	30	5.52	3.28	3.54	3.64	6.06	6.07	5.13	4.85	5.95	3.94	4.61	4.60	57.19
NEW ORLEANS, LA	30	5.87	5.47	5.24	5.02	4.62	6.83	6.20	6.15	5.55	3.05	5.09	5.07	64.16
SHREVEPORT, LA	30	4.60	4.21	4.18	4.42	5.25	5.05	3.99	2.71	3.21	4.45	4.68	4.55	51.30
CARIBOU, ME	30	2.97	2.06	2.57	2.64	3.28	3.31	3.89	4.15	3.27	2.99	3.12	3.19	37.44
PORTLAND, ME	30	4.09	3.14	4.14	4.26	3.82	3.28	3.32	3.05	3.37	4.40	4.72	4.24	45.83
BALTIMORE, MD	30	3.47	3.02	3.93	3.00	3.89	3.43	3.85	3.74	3.98	3.16	3.12	3.35	41.94
BLUE HILL, MA	30	4.78	4.06	4.79	4.32	3.79	3.93	3.74	4.06	4.13	4.42	4.64	4.56	51.22
BOSTON, MA	30	3.92	3.30	3.85	3.60	3.24	3.22	3.06	3.37	3.47	3.79	3.98	3.73	42.53
WORCESTER, MA	30	4.07	3.10	4.23	3.92	4.35	4.02	4.19	4.09	4.27	4.67	4.34	3.80	49.05
ALPENA, MI	30	1.76	1.35	2.13	2.31	2.61	2.53	3.17	3.50	2.80	2.33	2.08	1.83	28.40
DETROIT, MI	30	1.91	1.88	2.52	3.05	3.05	3.55	3.16	3.10	3.27	2.23	2.66	2.51	32.89
FLINT, MI	30	1.57	1.35	2.22	3.13	2.74	3.07	3.17	3.43	3.76	2.34	2.65	2.18	31.61
GRAND RAPIDS, MI	30	2.03	1.54	2.59	3.48	3.35	3.67	3.56	3.78	4.28	2.80	3.35	2.70	37.13
HOUGHTON LAKE, MI	30	1.61	1.25	2.05	2.29	2.57	2.93	2.75	3.72	3.11	2.26	2.14	1.75	28.43
LANSING, MI	30	1.61	1.45	2.33	3.09	2.71	3.60	2.68	3.46	3.48	2.29	2.66	2.17	31.53
MARQUETTE, MI	30	2.60	1.85	3.13	2.79	3.07	3.21	3.01	3.55	3.74	3.66	3.27	2.43	36.31
MUSKEGON, MI	30	2.22	1.58	2.36	2.91	2.95	2.58	2.32	3.77	3.52	2.80	3.23	2.64	32.88
SAULT STE. MARIE, MI	30	2.64	1.60	2.41	2.57	2.50	3.00	3.14	3.47	3.71	3.32	3.40	2.91	34.67
DULUTH, MN	30	1.12	0.83	1.69	2.09	2.95	4.25	4.20	4.22	4.13	2.46	2.12	0.94	31.00
INTERNATIONAL FALLS, MN	30	0.84	0.64	0.96	1.38	2.55	3.98	3.37	3.14	3.03	1.98	1.36	0.70	23.93
MINNEAPOLIS-ST. PAUL, MN	30	1.04	0.79	1.86	2.31	3.24	4.34	4.04	4.05	2.69	2.11	1.94	1.00	29.41
ROCHESTER, MN	30	0.94	0.75	1.88	3.01	3.53	4.00	4.61	4.33	3.12	2.20	2.01	1.02	31.40
SAINT CLOUD, MN	30	0.76	0.59	1.50	2.13	2.97	4.51	3.34	3.93	2.93	2.24	1.54	0.69	27.13
JACKSON, MS	30	5.67	4.50	5.74	5.98	4.86	3.82	4.69	3.66	3.23	3.42	5.04	5.34	55.95
MERIDIAN, MS	30	5.92	5.35	6.93	5.62	4.87	3.99	5.45	3.34	3.64	3.28	4.95	5.31	58.65
TUPELO, MS	30	5.14	4.68	6.30	4.94	5.80	4.82	3.65	2.67	3.35	3.38	5.01	6.12	55.86
COLUMBIA, MO	30	1.73	2.20	3.21	4.16	4.87	4.02	3.80	3.75	3.42	3.18	3.47	2.47	40.28
KANSAS CITY, MO	30	1.15	1.31	2.44	3.38	5.39	4.44	4.42	3.54	4.64	3.33	2.30	1.64	37.98
ST. LOUIS, MO	30	2.14	2.28	3.60	3.69	4.11	3.76	3.90	2.98	2.96	2.76	3.71	2.86	38.75
SPRINGFIELD, MO	30	2.11	2.28	3.82	4.31	4.57	5.02	3.56	3.37	4.83	3.47	4.46	3.17	44.97
BILLINGS, MT	30	0.81	0.58	1.12	1.74	2.48	1.89	1.28	0.85	1.34	1.26	0.75	0.67	14.77
GLASGOW, MT	30	0.35	0.26	0.47	0.75	1.72	2.20	1.78	1.25	0.98	0.71	0.39	0.37	11.23
GREAT FALLS, MT	30	0.68	0.51	1.01	1.40	2.53	2.24	1.45	1.65	1.23	0.93	0.59	0.67	14.89
HAVRE, MT	30	0.47	0.36	0.70	0.87	1.84	1.90	1.51	1.20	1.03	0.62	0.45	0.51	11.46
HELENA, MT	30	0.52	0.38	0.63	0.91	1.78	1.82	1.34	1.29	1.05	0.66	0.48	0.46	11.32
KALISPELL, MT	30	1.47	1.15	1.11	1.22	2.04	2.30	1.41	1.25	1.20	0.96	1.45	1.65	17.21

**RAINWATER CATCHMENT DESIGN AND INSTALLATION STANDARDS**

<b>NORMALS 1971-2000</b>	<b>YRS</b>	<b>JAN</b>	<b>FEB</b>	<b>MAR</b>	<b>APR</b>	<b>MAY</b>	<b>JUN</b>	<b>JUL</b>	<b>AUG</b>	<b>SEP</b>	<b>OCT</b>	<b>NOV</b>	<b>DEC</b>	<b>ANN</b>
MISSOULA, MT	30	1.06	0.77	0.96	1.09	1.95	1.73	1.09	1.15	1.08	0.83	0.96	1.15	13.82
GRAND ISLAND, NE	30	0.54	0.68	2.04	2.61	4.07	3.72	3.14	3.08	2.43	1.51	1.41	0.66	25.89
LINCOLN, NE	30	0.67	0.66	2.21	2.90	4.23	3.51	3.54	3.35	2.92	1.94	1.58	0.86	28.37
NORFOLK, NE	30	0.57	0.76	1.97	2.59	3.92	4.25	3.74	2.80	2.25	1.72	1.44	0.65	26.66
NORTH PLATTE, NE	30	0.39	0.51	1.24	1.97	3.34	3.17	3.17	2.15	1.32	1.24	0.76	0.40	19.66
OMAHA EPPLEY AP, NE	30	0.77	0.80	2.13	2.94	4.44	3.95	3.86	3.21	3.17	2.21	1.82	0.92	30.22
OMAHA (NORTH), NE	30	0.76	0.77	2.25	3.07	4.57	3.84	3.75	2.93	3.03	2.49	1.67	0.95	30.08
SCOTTSBLUFF, NE	30	0.54	0.58	1.16	1.79	2.70	2.65	2.13	1.19	1.22	1.01	0.80	0.56	16.33
VALENTINE, NE	30	0.30	0.48	1.11	1.97	3.20	3.01	3.37	2.20	1.61	1.22	0.72	0.33	19.52
ELKO, NV	30	1.14	0.88	0.98	0.81	1.08	0.67	0.30	0.36	0.68	0.71	1.05	0.93	9.59
ELY, NV	30	0.74	0.75	1.05	0.90	1.29	0.66	0.60	0.91	0.94	1.00	0.63	0.50	9.97
LAS VEGAS, NV	30	0.59	0.69	0.59	0.15	0.24	0.08	0.44	0.45	0.31	0.24	0.31	0.40	4.49
RENO, NV	30	1.06	1.06	0.86	0.35	0.62	0.47	0.24	0.27	0.45	0.42	0.80	0.88	7.48
WINNEMUCCA, NV	30	0.83	0.62	0.86	0.85	1.06	0.69	0.27	0.35	0.53	0.66	0.80	0.81	8.33
CONCORD, NH	30	2.97	2.36	3.04	3.07	3.33	3.10	3.37	3.21	3.16	3.46	3.57	2.96	37.60
MT. WASHINGTON, NH	30	8.52	7.33	9.42	8.43	8.21	8.36	8.02	8.08	8.55	7.66	10.49	8.84	101.91
ATLANTIC CITY AP, NJ	30	3.60	2.85	4.06	3.45	3.38	2.66	3.86	4.32	3.14	2.86	3.26	3.15	40.59
ATLANTIC CITY C.O.,NJ	30	3.44	2.88	3.79	3.25	3.16	2.46	3.36	4.16	3.02	2.71	2.96	3.18	38.37
NEWARK, NJ	30	3.98	2.96	4.21	3.92	4.46	3.40	4.68	4.02	4.01	3.16	3.88	3.57	46.25
ALBUQUERQUE, NM	30	0.49	0.44	0.61	0.50	0.60	0.65	1.27	1.73	1.07	1.00	0.62	0.49	9.47
CLAYTON, NM	30	0.30	0.27	0.62	0.99	2.08	2.21	2.81	2.69	1.56	0.74	0.54	0.32	15.13
ROSWELL, NM	30	0.39	0.41	0.35	0.58	1.30	1.62	1.99	2.31	1.98	1.29	0.53	0.59	13.34
ALBANY, NY	30	2.71	2.27	3.17	3.25	3.67	3.74	3.50	3.68	3.31	3.23	3.31	2.76	38.60
BINGHAMTON, NY	30	2.58	2.46	2.97	3.49	3.55	3.80	3.49	3.35	3.59	3.02	3.32	3.03	38.65
BUFFALO, NY	30	3.16	2.42	2.99	3.04	3.35	3.82	3.14	3.87	3.84	3.19	3.92	3.80	40.54
ISLIP, NY	30	4.27	3.33	4.76	4.13	3.90	3.71	2.93	4.48	3.39	3.63	3.86	4.13	46.52
NEW YORK C.PARK, NY	30	4.13	3.15	4.37	4.28	4.69	3.84	4.62	4.22	4.23	3.85	4.36	3.95	49.69
NEW YORK (JFK AP), NY	30	3.62	2.70	3.79	3.75	4.13	3.59	3.92	3.64	3.50	3.03	3.48	3.31	42.46
NEW YORK (LAGUARDIA AP), NY	30	3.56	2.75	3.93	3.68	4.16	3.57	4.41	4.09	3.77	3.26	3.67	3.51	44.36
ROCHESTER, NY	30	2.34	2.04	2.58	2.75	2.82	3.36	2.93	3.54	3.45	2.60	2.84	2.73	33.98
SYRACUSE, NY	30	2.60	2.12	3.02	3.39	3.39	3.71	4.02	3.56	4.15	3.20	3.77	3.12	40.05
ASHEVILLE, NC	30	4.06	3.83	4.59	3.50	4.42	4.38	3.87	4.30	3.72	3.18	3.82	3.40	47.07
CAPE HATTERAS, NC	30	5.84	3.94	4.95	3.29	3.92	3.82	4.95	6.56	5.68	5.31	4.93	4.56	57.75
CHARLOTTE, NC	30	4.00	3.55	4.39	2.95	3.66	3.42	3.79	3.72	3.83	3.66	3.36	3.18	43.51
GREENSBORO-WNSTN-SALM-NC	30	3.54	3.10	3.85	3.43	3.95	3.53	4.44	3.71	4.30	3.27	2.96	3.06	43.14
RALEIGH, NC	30	4.02	3.47	4.03	2.80	3.79	3.42	4.29	3.78	4.26	3.18	2.97	3.04	43.05
WILMINGTON, NC	30	4.52	3.66	4.22	2.94	4.40	5.36	7.62	7.31	6.79	3.21	3.26	3.78	57.07
BISMARCK, ND	30	0.45	0.51	0.85	1.46	2.22	2.59	2.58	2.15	1.61	1.28	0.70	0.44	16.84
FARGO, ND	30	0.76	0.59	1.17	1.37	2.61	3.51	2.88	2.52	2.18	1.97	1.06	0.57	21.19
GRAND FORKS, ND	30	0.68	0.58	0.89	1.23	2.21	3.03	3.06	2.72	1.96	1.70	0.99	0.55	19.60
WILLISTON, ND	30	0.54	0.39	0.74	1.05	1.88	2.36	2.28	1.48	1.35	0.87	0.65	0.57	14.16
AKRON, OH	30	2.49	2.28	3.15	3.39	3.96	3.55	4.02	3.65	3.43	2.53	3.04	2.98	38.47
CLEVELAND, OH	30	2.48	2.29	2.94	3.37	3.50	3.89	3.52	3.69	3.77	2.74	3.38	3.14	38.71
COLUMBUS, OH	30	2.53	2.20	2.89	3.25	3.88	4.08	4.62	3.72	2.92	2.31	3.19	2.93	38.52
DAYTON, OH	30	2.60	2.29	3.29	4.03	4.17	4.21	3.75	3.49	2.65	2.72	3.30	3.08	39.58
MANSFIELD, OH	30	2.63	2.17	3.36	4.17	4.42	4.52	4.23	4.60	3.44	2.68	3.76	3.26	43.24
TOLEDO, OH	30	1.93	1.88	2.62	3.24	3.14	3.80	2.80	3.19	2.84	2.35	2.78	2.64	33.21
YOUNGSTOWN, OH	30	2.34	2.03	3.05	3.33	3.45	3.91	4.10	3.43	3.89	2.46	3.07	2.96	38.02
OKLAHOMA CITY, OK	30	1.28	1.56	2.90	3.00	5.44	4.63	2.94	2.48	3.98	3.64	2.11	1.89	35.85
TULSA, OK	30	1.60	1.95	3.57	3.95	6.11	4.72	2.96	2.85	4.76	4.05	3.47	2.43	42.42

**RAINWATER CATCHMENT DESIGN AND INSTALLATION STANDARDS**

<b>NORMALS 1971-2000</b>	<b>YRS</b>	<b>JAN</b>	<b>FEB</b>	<b>MAR</b>	<b>APR</b>	<b>MAY</b>	<b>JUN</b>	<b>JUL</b>	<b>AUG</b>	<b>SEP</b>	<b>OCT</b>	<b>NOV</b>	<b>DEC</b>	<b>ANN</b>
ASTORIA, OR	30	9.62	7.87	7.37	4.93	3.28	2.57	1.16	1.21	2.61	5.61	10.50	10.40	67.13
BURNS,OR	30	1.18	1.11	1.24	0.85	1.05	0.66	0.40	0.45	0.50	0.72	1.11	1.30	10.57
EUGENE, OR	30	7.65	6.35	5.80	3.66	2.66	1.53	0.64	0.99	1.54	3.35	8.44	8.29	50.90
MEDFORD, OR	30	2.47	2.10	1.85	1.31	1.21	0.68	0.31	0.52	0.78	1.31	2.93	2.90	18.37
PENDLETON, OR	30	1.45	1.22	1.26	1.13	1.22	0.78	0.41	0.56	0.63	0.99	1.63	1.48	12.76
PORTLAND, OR	30	5.07	4.18	3.71	2.64	2.38	1.59	0.72	0.93	1.65	2.88	5.61	5.71	37.07
SALEM, OR	30	5.84	5.09	4.17	2.76	2.13	1.45	0.57	0.68	1.43	3.03	6.39	6.46	40.00
SEXTON SUMMIT, OR	30	4.71	4.29	3.92	2.38	1.35	0.94	0.35	0.61	1.20	2.93	5.32	5.18	33.18
ALLENTOWN, PA	30	3.50	2.75	3.56	3.49	4.47	3.99	4.27	4.35	4.37	3.33	3.70	3.39	45.17
ERIE, PA.	30	2.53	2.28	3.13	3.38	3.34	4.28	3.28	4.21	4.73	3.92	3.96	3.73	42.77
HARRISBURG, PA	30	3.18	2.88	3.58	3.31	4.60	3.99	3.21	3.24	3.65	3.06	3.53	3.22	41.45
MIDDLETOWN/HARRISBURG APT	30	3.18	2.88	3.58	3.31	4.60	3.99	3.21	3.24	3.65	3.06	3.53	3.22	41.45
PHILADELPHIA, PA	30	3.52	2.74	3.81	3.49	3.89	3.29	4.39	3.82	3.88	2.75	3.16	3.31	42.05
PITTSBURGH, PA	30	2.70	2.37	3.17	3.01	3.80	4.12	3.96	3.38	3.21	2.25	3.02	2.86	37.85
AVOCA, PA	30	2.46	2.08	2.69	3.28	3.69	3.97	3.74	3.10	3.86	3.02	3.12	2.55	37.56
WILLIAMSPORT, PA	30	2.85	2.61	3.21	3.49	3.79	4.45	4.08	3.38	3.98	3.19	3.62	2.94	41.59
BLOCK IS.,RI	30	3.68	3.04	3.99	3.72	3.40	2.77	2.62	3.00	3.19	3.04	3.77	3.57	39.79
PROVIDENCE, RI	30	4.37	3.45	4.43	4.16	3.66	3.38	3.17	3.90	3.70	3.69	4.40	4.14	46.45
CHARLESTON AP,SC	30	4.08	3.08	4.00	2.77	3.67	5.92	6.13	6.91	5.98	3.09	2.66	3.24	51.53
CHARLESTON C.O.,SC	30	3.62	2.62	3.83	2.44	2.77	4.96	5.50	6.54	6.13	3.02	2.18	2.78	46.39
COLUMBIA, SC	30	4.66	3.84	4.59	2.98	3.17	4.99	5.54	5.41	3.94	2.89	2.88	3.38	48.27
GREENV'L-SPARTANB'RG AP, SC	30	4.41	4.24	5.31	3.54	4.59	3.92	4.65	4.08	3.97	3.88	3.79	3.86	50.24
ABERDEEN, SD	30	0.48	0.48	1.34	1.83	2.69	3.49	2.92	2.42	1.81	1.63	0.75	0.38	20.22
HURON, SD	30	0.49	0.57	1.67	2.29	3.00	3.28	2.86	2.07	1.80	1.59	0.89	0.39	20.90
RAPID CITY, SD	30	0.37	0.46	1.03	1.86	2.96	2.83	2.03	1.61	1.10	1.37	0.61	0.41	16.64
SIOUX FALLS, SD	30	0.51	0.51	1.81	2.65	3.39	3.49	2.93	3.01	2.58	1.93	1.36	0.52	24.69
BRISTOL-JOHNSON CTY TN	30	3.52	3.40	3.91	3.23	4.32	3.89	4.21	3.00	3.08	2.30	3.08	3.39	41.33
CHATTANOOGA, TN	30	5.40	4.85	6.19	4.23	4.28	3.99	4.73	3.59	4.31	3.26	4.88	4.81	54.52
KNOXVILLE, TN	30	4.57	4.01	5.17	3.99	4.68	4.04	4.71	2.89	3.04	2.65	3.98	4.49	48.22
MEMPHIS, TN	30	4.24	4.31	5.58	5.79	5.15	4.30	4.22	3.00	3.31	3.31	5.76	5.68	54.65
NASHVILLE, TN	30	3.97	3.69	4.87	3.93	5.07	4.08	3.77	3.28	3.59	2.87	4.45	4.54	48.11
OAK RIDGE,TN	30	5.13	4.50	5.72	4.32	5.14	4.64	5.16	3.39	3.75	3.02	4.86	5.42	55.05
ABILENE, TX	30	0.97	1.13	1.41	1.67	2.83	3.06	1.70	2.63	2.91	2.90	1.30	1.27	23.78
AMARILLO, TX	30	0.63	0.55	1.13	1.33	2.50	3.28	2.68	2.94	1.88	1.50	0.68	0.61	19.71
AUSTIN/CITY, TX	30	1.89	1.99	2.14	2.51	5.03	3.81	1.97	2.31	2.91	3.97	2.68	2.44	33.65
AUSTIN/BERGSTROM, TX	30	2.21	2.02	2.36	2.63	5.12	3.42	2.03	2.51	2.88	3.99	3.02	2.53	34.72
BROWNSVILLE, TX	30	1.36	1.18	0.93	1.96	2.48	2.93	1.77	2.99	5.31	3.78	1.75	1.11	27.55
CORPUS CHRISTI, TX	30	1.62	1.84	1.74	2.05	3.48	3.53	2.00	3.54	5.03	3.94	1.74	1.75	32.26
DALLAS-FORT WORTH, TX 30		1.90	2.37	3.06	3.20	5.15	3.23	2.12	2.03	2.42	4.11	2.57	2.57	34.73
DALLAS-LOVE FIELD, TX	30	1.89	2.31	3.13	3.46	5.30	3.92	2.43	2.17	2.65	4.65	2.61	2.53	37.05
DEL RIO, TX	30	0.57	0.96	0.96	1.71	2.31	2.34	2.02	2.16	2.06	2.00	0.96	0.75	18.80
EL PASO, TX	30	0.45	0.39	0.26	0.23	0.38	0.87	1.49	1.75	1.61	0.81	0.42	0.77	9.43
GALVESTON, TX	30	4.08	2.61	2.76	2.56	3.70	4.04	3.45	4.22	5.76	3.49	3.64	3.53	43.84
HOUSTON, TX	30	3.68	2.98	3.36	3.60	5.15	5.35	3.18	3.83	4.33	4.50	4.19	3.69	47.84
LUBBOCK, TX	30	0.50	0.71	0.76	1.29	2.31	2.98	2.13	2.36	2.57	1.70	0.71	0.67	18.69
MIDLAND-ODESSA, TX	30	0.53	0.58	0.42	0.73	1.79	1.71	1.89	1.77	2.31	1.77	0.65	0.65	14.80
PORT ARTHUR, TX	30	5.69	3.35	3.75	3.84	5.83	6.58	5.23	4.85	6.10	4.67	4.75	5.25	59.89
SAN ANGELO, TX	30	0.82	1.18	0.99	1.60	3.09	2.52	1.10	2.05	2.95	2.57	1.10	0.94	20.91

**RAINWATER CATCHMENT DESIGN AND INSTALLATION STANDARDS**

<b>NORMALS 1971-2000</b>	<b>YRS</b>	<b>JAN</b>	<b>FEB</b>	<b>MAR</b>	<b>APR</b>	<b>MAY</b>	<b>JUN</b>	<b>JUL</b>	<b>AUG</b>	<b>SEP</b>	<b>OCT</b>	<b>NOV</b>	<b>DEC</b>	<b>ANN</b>
SAN ANTONIO, TX	30	1.66	1.75	1.89	2.60	4.72	4.30	2.03	2.57	3.00	3.86	2.58	1.96	32.92
VICTORIA, TX	30	2.44	2.04	2.25	2.97	5.12	4.96	2.90	3.05	5.00	4.26	2.64	2.47	40.10
WACO, TX	30	1.90	2.43	2.48	2.99	4.46	3.08	2.23	1.85	2.88	3.67	2.61	2.76	33.34
WICHITA FALLS, TX	30	1.12	1.58	2.27	2.62	3.92	3.69	1.58	2.39	3.19	3.11	1.68	1.68	28.83
MILFORD, UT	30	0.73	0.77	1.21	0.99	0.94	0.44	0.76	1.04	0.92	1.12	0.77	0.58	10.27
SALT LAKE CITY, UT	30	1.37	1.33	1.91	2.02	2.09	0.77	0.72	0.76	1.33	1.57	1.40	1.23	16.50
BURLINGTON, VT	30	2.22	1.67	2.32	2.88	3.32	3.43	3.97	4.01	3.83	3.12	3.06	2.22	36.05
LYNCHBURG, VA	30	3.54	3.10	3.83	3.46	4.11	3.79	4.39	3.41	3.88	3.39	3.18	3.23	43.31
NORFOLK, VA	30	3.93	3.34	4.08	3.38	3.74	3.77	5.17	4.79	4.06	3.47	2.98	3.03	45.74
RICHMOND, VA	30	3.55	2.98	4.09	3.18	3.96	3.54	4.67	4.18	3.98	3.60	3.06	3.12	43.91
ROANOKE, VA	30	3.23	3.08	3.84	3.61	4.24	3.68	4.00	3.74	3.85	3.15	3.21	2.86	42.49
OLYMPIA, WA	30	7.54	6.17	5.29	3.58	2.27	1.78	0.82	1.10	2.03	4.19	8.13	7.89	50.79
QUILLAYUTE, WA	30	13.65	12.35	10.98	7.44	5.51	3.50	2.34	2.67	4.15	9.81	14.82	14.50	101.72
SEATTLE C.O., WA	30	5.24	4.09	3.92	2.75	2.03	1.55	0.93	1.16	1.61	3.24	5.67	6.06	38.25
SEATTLE SEA-TAC AP, WA	30	5.13	4.18	3.75	2.59	1.78	1.49	0.79	1.02	1.63	3.19	5.90	5.62	37.07
SPOKANE, WA	30	1.82	1.51	1.53	1.28	1.60	1.18	0.76	0.68	0.76	1.06	2.24	2.25	16.67
WALLA WALLA WA	30	2.25	1.97	2.20	1.83	1.95	1.15	0.73	0.84	0.83	1.77	2.85	2.51	20.88
YAKIMA, WA	30	1.17	0.80	0.70	0.53	0.51	0.62	0.22	0.36	0.39	0.53	1.05	1.38	8.26
BECKLEY, WV	30	3.23	2.96	3.63	3.43	4.39	3.92	4.78	3.45	3.23	2.64	2.88	3.09	41.63
CHARLESTON, WV	30	3.25	3.19	3.90	3.25	4.30	4.09	4.86	4.11	3.45	2.67	3.66	3.32	44.05
ELKINS, WV	30	3.43	3.20	3.92	3.53	4.77	4.61	4.84	4.26	3.83	2.86	3.42	3.44	46.11
HUNTINGTON, WV	30	3.21	3.09	3.83	3.33	4.41	3.88	4.46	3.88	2.80	2.73	3.32	3.37	42.31
GREEN BAY, WI	30	1.21	1.01	2.06	2.56	2.75	3.43	3.44	3.77	3.11	2.17	2.27	1.41	29.19
LA CROSSE, WI	30	1.19	0.99	2.00	3.38	3.38	4.00	4.25	4.28	3.40	2.16	2.10	1.23	32.36
MADISON, WI	30	1.25	1.28	2.28	3.35	3.25	4.05	3.93	4.33	3.08	2.18	2.31	1.66	32.95
MILWAUKEE, WI	30	1.85	1.65	2.59	3.78	3.06	3.56	3.58	4.03	3.30	2.49	2.70	2.22	34.81
CASPER, WY	30	0.58	0.64	0.90	1.52	2.38	1.43	1.29	0.73	0.98	1.14	0.82	0.62	13.03
CHEYENNE, WY	30	0.45	0.44	1.05	1.55	2.48	2.12	2.26	1.82	1.43	0.75	0.64	0.46	15.45
LANDER, WY	30	0.52	0.54	1.24	2.07	2.38	1.15	0.84	0.57	1.14	1.37	0.99	0.61	13.42
SHERIDAN, WY	30	0.77	0.57	1.00	1.77	2.41	2.02	1.11	0.80	1.38	1.41	0.80	0.68	14.72
GUAM, PC	30	5.58	5.11	4.24	4.16	6.39	6.28	11.66	16.17	13.69	11.88	9.34	6.11	100.61
JOHNSTON ISLAND, PC	30	1.64	1.29	2.01	1.86	1.14	0.87	1.40	2.07	2.46	2.78	4.78	2.70	25.00
KOROR, PC	30	11.20	9.65	8.79	9.45	11.27	17.54	16.99	14.47	11.65	13.41	11.62	12.33	148.37
KWAJALEIN, MARSHALL IS., PC	30	5.12	3.73	3.82	7.63	8.62	8.86	10.24	10.42	11.82	11.46	10.74	7.94	100.40
MAJURO, MARSHALL IS., PC	30	8.09	6.86	8.43	11.30	11.53	11.09	12.41	11.95	11.96	13.73	12.81	11.50	131.66
PAGO PAGO, AMER SAMOA, PC	30	14.02	12.14	11.15	11.16	10.43	5.94	5.76	6.43	7.36	10.03	11.16	13.38	118.96
POHNPEI, CAROLINE IS., PC	30	12.52	9.78	13.96	16.94	19.41	17.06	16.72	16.37	14.94	16.30	14.74	15.87	184.61
CHUUK, E. CAROLINE IS., PC	30	8.58	8.77	8.15	10.94	11.29	12.82	12.45	15.09	13.12	10.69	11.09	10.98	133.97
WAKE ISLAND, PC	30	1.40	1.89	2.38	2.11	1.70	1.95	3.44	5.62	4.82	4.27	2.78	1.87	34.23
YAP, W CAROLINE IS., PC	30	7.24	5.45	6.14	5.58	8.15	13.46	13.25	14.41	13.53	12.25	8.82	9.34	117.62
SAN JUAN, PR	30	3.02	2.30	2.14	3.71	5.29	3.52	4.16	5.22	5.60	5.06	6.17	4.57	50.76