

CONTRACT DOCUMENTS

for the construction of the

REPAIR OF THE
ADMINISTRATION BUILDING ROOF
AT THE
RICHARD A. HEYMAN
ENVIRONMENTAL PROTECTION FACILITY



Prepared for the
City of Key West
Key West, Florida

Specifications and Drawings

For information regarding
this project, contact:

ANDREW SMYTH, P.E.
6410 5th Street, Suite 2-A
Key West, FL 33040
305-294-1645

CH2MHILL

EB0000072 AAC001992

CH2M Hill Project No. 650974

AUGUST 2015

KEY WEST PROJECT No. SE1402

ITB # 15-018

BID DOCUMENTS

**CITY OF KEY WEST
KEY WEST, FLORIDA**

BID DOCUMENTS

for construction of the

**REPAIR OF THE ADMINISTRATION BUILDING ROOF
AT THE RICHARD A. HEYMAN EPF**

CONSISTING OF:
BIDDING REQUIREMENTS
CONTRACT FORMS
CONDITIONS OF THE CONTRACT
TECHNICAL SPECIFICATIONS
DRAWINGS

CH2M HILL
Key West, FL
August 2015

TABLE OF CONTENTS**PART 1—PROCUREMENT REQUIREMENTS**

00 11 13	Invitation to Bid	1-	3
00 11 13.01	Statement of No Bid.....	1-	1
00 21 13	Instructions to Bidders	1-	8
00 41 13	Bid Form	1-	6
00 43 13	Florida Bid Bond	1-	2
00 43 16	Anti-Kickback Affidavit.....	1-	1
00 43 17	Public Entity Crimes Form	1-	2
00 43 18	City of Key West Indemnification Form	1-	1
00 43 19	Equal Benefits for Domestic Partners Affidavit.....	1-	5
00 43 20	City of Key West Business License Tax Receipt/Application	1-	2
00 43 21	Cone of Silence Affidavit	1-	5
00 43 22	Local Vendor Certification	1-	1
00 44 00	Bidders Checklist.....	1-	1
00 44 01	Disclosure of Lobbying Activities Form	1-	4
00 44 02	Non-Collusion Declaration and Compliance Form	1-	3
00 44 04	Suspension and Debarment Certification	1-	1

PART 2—CONTRACTING REQUIREMENTS**CONTRACTING FORMS**

00 52 13	Agreement.....	1-	2
----------	----------------	----	---

PROJECT FORMS

00 61 13.13	Performance Bond	1-	3
00 61 13.16	Payment Bond.....	1-	2
00 62 00	Notice of Award.....	1-	1
00 62 01	Certificate of Substantial Completion.....	1-	1
00 62 02	Certificate of Final Completion	1-	1
00 62 04	Notice to Proceed.....	1-	1
00 63 00	Payment Application and Certificate.....	1-	1
00 63 01	Construction Compliance Certification with Specifications and Plans	1-	1
00 63 02	Certificate of Final Payment.....	1-	2

	<u>Pages</u>
<u>CONDITIONS OF THE CONTRACT</u>	
00 72 00	General Conditions 1- 40
00 73 00	Supplementary Conditions..... 1- 11
	Exhibit A: Certificate of Liability Insurance
	Exhibit B: Additional Insured-Owner’s, Lessees or Contractors- Scheduled Person or Organization
	Exhibit C: Additional Insured-Owner’s, Lessees or Contractors- Completed Operations
	Exhibit D: Earlier Notice of Cancellation Provided by Us
	Exhibit E: Waiver of Transfer of Rights of Recovery Against Others to Us
	Exhibit F: Waiver of Our Right to Recover from Others Endorsement
	Exhibit G: Rapid Gate: Tenant Brief: NAS Key West

PART 3—SPECIFICATIONS**DIVISION 1—GENERAL REQUIREMENTS**

01 01 00	General Requirements 1- 10
01 11 00	Summary of Work..... 1- 1
01 29 00	Payment Procedures..... 1- 3
01 31 19	Project Meetings 1- 3
01 32 00	Progress Schedules 1- 6
01 33 00	Submittals 1- 9
	Transmittal of Contractor’s Submittal
01 42 13	Abbreviations..... 1- 3
01 43 33	Manufacturers’ Field Services 1- 3
	Manufacturer’s Certificate of Compliance Form
	Manufacturer’s Certificate of Proper Installation Form
01 50 00	Construction Facilities and Temporary Controls..... 1- 5
01 77 00	Contract Closeout 1- 4

DIVISION 2—EXISTING CONDITIONS (NOT USED)**DIVISION 3—CONCRETE**

03 30 10	Reinforced Concrete 1- 7
----------	--------------------------------

DIVISION 4—MASONRY (NOT USED)**DIVISION 5—METALS**

05 50 00	Metal Fabrications - Ladders 1- 10
----------	--

Pages

DIVISION 6—WOOD, PLASTICS, AND COMPOSITES (NOT USED)

DIVISION 7—THERMAL AND MOISTURE PROTECTION

07 52 17	Modified Bitumen Sheet Roofing Over Concrete Substrate ...	1-	13
07 62 00	Sheet Metal Flashing	1-	7
07 70 01	Roof Specialties and Accessories	1-	4

DIVISIONS 8 THROUGH 25 (NOT USED)

DIVISION 26 – ELECTRICAL

26 41 00	Facility Lightning Protection	1-	6
----------	-------------------------------------	----	---

DIVISIONS 27 THROUGH 49 (NOT USED)

PART 4—DRAWINGS

END OF SECTION

PART 1

PROCUREMENT REQUIREMENTS

INVITATION TO BID

Sealed Bids for the **City of Key West Repair of the Administration Building Roof at the Richard A. Heyman EPF (ITB#15-018)**, addressed to the City of Key West, will be received at the Office of the City Clerk, City of Key West, 3126 Flagler Avenue, Key West Florida, 33040, until **3:00 p.m., local time, September 23, 2015**, and then will be publicly opened and read. Any Bids received after the time and date specified will not be considered.

Please submit two (2) originals and two (2) USB Drives with one single PDF file of the entire bid package on each USB Drive. Bid package is to be enclosed in a sealed envelope, clearly marked on the outside “**BID FOR REPAIR OF THE ADMINISTRATION BUILDING ROOF AT THE RICHARD A. HEYMAN EPF**” addressed and delivered to the City Clerk at the address noted above.

The Project contemplated consists of items of Work required for roof repair to the Administration Building including demolition of the existing roof systems, roof membrane, walk pad, metal flashing installations, removal and re-installation of the lightning protection, and all Work associated with the construction. The location of the Work is at the Richard A. Heyman Environmental Protection Facility in the City of Key West.

Drawings and Specifications may be obtained from Demand Star by Onvia. Please contact Demand Star at www.demandstar.com or call 1-800-711-1712. Also available on the City website: www.CityofKeyWest-fl.gov.

A **Mandatory** Pre-Bid Conference will, be held in at **10:00 a.m.** on **September 3, 2015**, at the City of Key West Richard A. Heyman EPF on Fleming Key, Trumbo Point Annex, Key West, FL. Meeting attendees shall assemble at guard shelter parking lot. All attendees are required to obtain a day pass from the Navy. A day pass requires a vehicle inspection at the Boca Chica Commercial Gate: hours of operation are from 7:00 a.m. to 10:00 a.m., Monday through Friday. **Attendees are encouraged to contact RAPID GATE at 1-877-RAPID Gate to answer any questions.**

Each Bid must be submitted on the prescribed form and accompanied by Bid security as prescribed in the Instructions to Bidders, payable to the City of Key West, Florida, in an amount not less than (5) five percent of the amount of the Bid. The Contractor shall be a licensed contractor by the State of Florida and submit proof of such with the Bid.

The Successful Bidder will be required to furnish the necessary additional bond(s) for the faithful performance of the Contract, as prescribed in the Bidding Documents. The Bidder will also be required to furnish documentation showing that they are in compliance with the licensing requirements of the State and the provisions of Chapter 66 Section 87 of the Code of Ordinances of the City of Key West. Compliance with these provisions is required before the Contractor can enter into the agreement contained in the Contract Documents.

Specifically, Bidder shall demonstrate that they hold, as a minimum, the following licenses and certificates required by State Statute and local codes.

EACH BID MUST BE SUBMITTED ON THE PRESCRIBED FORM AND ACCOMPANIED BY BID SECURITY AS PRESCRIBED IN THE INSTRUCTIONS TO BIDDERS, PAYABLE TO THE CITY OF KEY WEST, FLORIDA, IN AN AMOUNT NOT LESS THAN FIVE (5) PERCENT OF THE AMOUNT BID.

THE BIDDER MUST BE A LICENSED CONTRACTOR BY THE STATE OF FLORIDA AND SUBMIT PROOF OF SUCH WITH THE BID.

The Bidder shall furnish documentation showing that he is in compliance with the licensing requirements of the provisions of Chapter 66 Section 87 of the Code of Ordinances of the City of Key West; within 10 days the following the Notice of Award and the following documentation:

1. City of Key West Tax License Receipt.

All Bid bonds, contract bonds, insurance contracts, and certificates of insurance shall be either executed by or countersigned by a licensed resident agent of the Surety or Insurance Company having his place of business in the State of Florida, and in all ways complying with the insurance laws of the State of Florida. Further, the said Surety or Insurance Company shall be duly licensed and qualified to do business in the State of Florida.

Before a Contract will be awarded for the Work contemplated herein, the City will conduct such investigation as is necessary to determine the performance record and ability of the Apparent Low Bidder to perform the size and type of work specified under this Contract. Upon request, the Bidder shall submit such information as deemed necessary by the City to evaluate the Bidder's qualifications.

For information concerning the proposed work or for appointment to visit the Site of the proposed work, contact the designated Engineer by the General Services and Utilities Department of the City of Key West.

As stated above at the time of the Bid submittal the Bidder must provide satisfactory documentation of State Licenses. The Bidder shall furnish documentation showing that they are in compliance with the licensing requirements of County, and City licenses as would be required within 10 days of the Award. The Successful Bidder must also be able to satisfy the City Attorney as to such insurance coverage and legal requirements as may be demanded by the Bid in question.

The City may reject Bids for any and/or all of the following reasons: 1) for budgetary reasons; 2) if the Bidder misstates or conceals a material fact in its Bid, 3) if the Bid does not strictly conform to the law or is non-responsive to the bid requirements; 4) if the Bid is conditional; 5) if a change of circumstances occurs making the purpose of the Bid unnecessary to the City; or 6) if such rejection is in the best interest of the City. The City may also waive any minor formalities or irregularities in any Bid.

Dated this _____ day of _____, 20__

CITY OF KEY WEST

By _____
Jim Scholl, City Manager

END OF SECTION

STATEMENT OF NO BID #ITB

**REPAIR OF THE ADMINISTRATION BUILDING ROOF
AT THE RICHARD A. HEYMAN EPF**

NOTE: IF YOU DO NOT INTEND TO BID, PLEASE RETURN THIS FORM ONLY

CITY OF KEY WEST
FINANCE DEPARTMENT
P.O. BOX 1409
KEY WEST, FLORIDA 33040
ATTN: S. SNIDER

We, the undersigned have declined to bid on the above-noted Invitation to Bid for the following reason(s):

- Insufficient time to respond to Invitation to Bid
- Do not offer this product
- Our schedule will not permit us to perform
- Unable to meet specifications
- Specifications unclear (please explain below)
- Remove us from your "Bidder Mailing List"
- Other (Please specify below)

We understand that if a "No Bid" statement is not returned, our name may be removed from the Bidder's list of the City of Key West.

COMPANY
NAME: _____

AUTHORIZED
AGENT _____

COMPANY
ADDRESS _____

DATE: _____ TELEPHONE: _____

INSTRUCTIONS TO BIDDERS

1. CONTRACT DOCUMENTS

1.1. Format: The Contract Documents are divided into parts, divisions, and sections for convenient organization and reference. Generally, there has been no attempt to divide the Specification sections into work performed by the various building trades, Work by separate subcontractors, or work required for separate facilities in the Project.

1.2. Document Interpretation:

1.2.1. The separate sections contained within these Contract Documents are intended to be mutually cooperative and to provide all details reasonably required for the execution of the proposed Work.

1.2.2. Should there be any doubt as to the meaning or intent of said Contract Documents, the Bidder should request of the Engineer, in writing (at least 6 working days prior to Bid opening) an interpretation thereof. Any interpretation or change in said Contract Documents will be made only in writing, in the form of Addenda to the Documents which will be furnished to all registered holders of Contract Documents. Bidders shall submit with their Bid, or indicate receipt of, all Addenda. The Owner will not be responsible for any other explanation or interpretations of said Documents.

1.3. Drawings: Details of construction are attached.

2. GENERAL DESCRIPTION OF THE PROJECT

2.1. A general description of the Work to be done is contained in the Invitation to Bid. The scope is specified in applicable parts of these Contract Documents.

3. QUALIFICATION OF CONTRACTORS

3.1. The prospective Bidders must meet the statutorily prescribed requirements before award of Contract by the Owner.

3.2. Bidders must hold or obtain all licenses or certificates required by federal, state, or local statutes, or regulations in order to Bid and perform the Work specified herein.

3.3. Prior to Award of Contract:

3.3.1. Letter from the proposed primary roofing manufacturer confirming that identified Subcontractor is an acceptable Contractor authorized to install the proposed system.

3.3.2. Letter from the primary roofing manufacturer stating that the proposed application will comply with Specifications and that application will comply with manufacturer's requirement in order to qualify the Project for the guarantee.

3.3.3. Administrative Submittals: Proposed maintenance agreement and proposed sample warranty.

4. BIDDER'S UNDERSTANDING

4.1. Each Bidder must inform himself of the conditions relating to the execution of the Work, and it is assumed that he will inspect the site and make himself thoroughly familiar with all the Contract Documents. Failure to do so will not relieve the successful Bidder of his obligation to enter into a Contract and complete the contemplated Work in strict accordance with the Contract Documents. It shall be the Bidder's obligation to verify for himself and to his complete satisfaction all information concerning site and subsurface conditions.

4.2. The Owner will make available to prospective Bidders upon request and at the office of the Engineer, prior to Bid opening, any information that he may have as to subsurface conditions and surface topography at the Work Site.

4.3. Information derived from inspection of topographic maps, or from Drawings showing location of utilities and structures will not in any way relieve the Contractor from any risk, or from properly examining the Site and making such additional investigations as he may elect, or from properly fulfilling all the terms of the Contract Documents.

4.4. Each Bidder shall inform himself of, and the Bidder awarded a Contract shall comply with, federal, state, and local laws, statutes, and ordinances relative to the execution of the Work. This requirement includes, but is not limited to, applicable regulations concerning minimum wage rates, nondiscrimination in the employment of labor, protection of public and employee safety and health, environmental protection, the protection of natural resources, fire protection, burning and non-burning requirements, permits, fees, and similar subjects.

5. TYPE OF PROPOSAL

5.1. Lump Sum:

5.1.1. The Proposal for the Work is to be submitted on a lump sum basis. All items required to complete the Work specified or shown on the Drawings but not included in the Proposal shall be considered incidental to those set forth in the Proposal. Payment to the Contractor will be made on the measurement of the Work actually performed by the Contractor as specified in the Contract Documents.

6. PREPARATION OF PROPOSALS

6.1. General:

6.1.1. All blank spaces in the Bid form must be filled in for all schedules and associated parts, as required, preferably in BLACK ink. All price information shall be clearly shown in figures where required. No changes shall be made in the phraseology of the forms. In case of discrepancy between unit prices and extended totals, unit prices shall prevail.

6.1.2. Any Bid shall be deemed informal which contains omissions, erasures, alterations, or additions of any kind, or prices uncalled for, or in which any of the prices are obviously unbalanced, or which in any manner shall fail to conform to the conditions of the published Invitation to Bid.

6.1.3. Only one Bid from any individual, firm, partnership, or corporation, under the same or different names, will be considered. Should it appear to the Owner that any Bidder is interested in more than one Bid for work contemplated, all Bids in which such Bidder is interested will be rejected.

6.2. Description of Suppliers: The manufacturer name, trade name, brand name, or catalog number used in the Specifications is for the purpose of describing and establishing equipment that has been presented for this Project. Other equipment will not be accepted.

6.3. Signature: The Bidder shall sign his Bid in the blank space provided therefore. If Bidder is a corporation, the legal name of the corporation shall be set forth above, together with the signature of the officer or officers authorized to sign Contracts on behalf of the corporation. If Bidder is a partnership, the true name of the firm shall be set forth above, together with the signature of the partner or partners authorized to sign Contracts in behalf of the partnership. If signature is by an agent, other than an officer of a corporation or a member of a partnership, a notarized power-of-attorney must be on file with the Owner prior to opening of Bids or submitted with the Bid, otherwise the Bid will be regarded as not properly authorized.

6.4. Special Bidding Requirements:

6.4.1. The Bidder's attention is brought to the hiring practices and licenses and permits of the City of Key West.

6.4.2. The Bidder shall submit with his Bid his experience record showing his experience and expertise roof repair, demolition and construction for restoration work (e.g., pavement, curbing, landscaping, etc.). Such experience record shall provide at least five current or recent projects of similar work, preferably within Florida or the southeastern United States. For each project the following information shall be provided:

- 6.4.2.1. Description and location of work.
- 6.4.2.2. Contract amount.
- 6.4.2.3. Dates work was performed.
- 6.4.2.4. Owner.
- 6.4.2.5. Name of Owner's contact person and phone number.
- 6.4.2.6. Engineer.
- 6.4.2.7. Name of Engineer's contact person and phone number.

6.5. Attachments:

- 6.5.1. Bidder shall complete and submit the following forms with this Bid:
 - 6.5.1.1. Anti-Kickback Affidavit.
 - 6.5.1.2. Public Entity Crimes.
 - 6.5.1.3. Key West Indemnification Form.
 - 6.5.1.4. Disclosure of Lobbying Activities.
 - 6.5.1.5. Non-Collusion Declaration and Compliance with 49 CFR §29.
 - 6.5.1.6. Suspension and Debarment Certification.
 - 6.5.1.7. Equal Benefits for Domestic Partners Affidavit.
 - 6.5.1.8. Cone of Silence.

6.6. Public Entity Crimes: A person or affiliate who has been placed on the convicted vendor list following a conviction for a public entity crime may not submit a Bid on a contract to provide any goods or services to a public entity, may not submit a Bid on a contract with a public entity for the construction or repair of a public building or public work, may not submit Bids on leases of real property to a public entity, may not be awarded or perform work as a Contractor, Supplier, Subcontractor, or consultant under a contract with any public entity and may not transact business with any public entity in excess of the threshold amount provided in Section 287.017, for CATEGORY TWO for a period of 36 months from the date of being placed on the convicted vendor list.”

- 6.7. City of Key West License Required: Contractor is required to have a Certified or registered Electrical Contractors City of Key West license and a Certified or Registered General Contractors City of Key West license. License fees not to exceed \$350.00. License shall be obtained within 10 (ten) days of Notice of Award.
- 6.8. Anti-Kickback Affidavit: The Bidder shall submit a signed and notarized Anti-Kickback Affidavit with Bid on the form provided herein.
- 6.9. FALL PROTECTION: The Scope of Work, includes but is not limited to, replacement of parapets, removal of roof equipment and repair of roof openings. The General Contractor shall provide appropriate fall protection for workers according to OSHA and Florida Safety and Fall Protection, as appropriate.
7. STATE AND LOCAL SALES AND USE TAXES
- 7.1. Unless the Supplementary Conditions contains a statement that the Owner is exempt from state sales tax on materials incorporated into the work due to the qualification of the Work under this Contract, all state and local sales and use taxes, as required by the laws and statutes of the state and its political subdivisions, shall be paid by the Contractor. Prices quoted in the Bid shall include all nonexempt sales and use taxes, unless provision is made in the Bid form to separately itemize the tax.
8. SUBMISSION OF PROPOSALS
- 8.1. All Bids must be submitted not later than the time prescribed, at the place, and in the manner set forth in the Invitation to Bid. Bids must be made on the Bid forms provided herewith. The Bidder shall submit TWO (2) ORIGINALS and TWO (2) ELECTRONIC COPIES ON USB DRIVES WITH A SINGLE PDF FILE OF THE FULL PROPOSAL and all required bonds, attachments, and forms.
- 8.2. Each Bid must be submitted in two sealed envelope one within the other, so marked as to indicate the Bidder's name and its contents without being opened, and addressed in conformance with the instructions in the Invitation to Bid.
9. MODIFICATION OR WITHDRAWAL OF PROPOSALS
- 9.1. Prior to the time and date designated for receipt of Bids, any Bid submitted may be withdrawn by notice to the party receiving Bids at the place designated for receipt of Bids. Such notice shall be in writing over the signature of the Bidder or by telegram. If by telegram, written confirmation over the signature of the Bidder shall be mailed and postmarked on or before the date and time set for receipt of Bids. No Bid may be withdrawn after the time scheduled for opening of Bids, unless the time specified in paragraph Award of Contract of these Instructions to Bidders shall have elapsed.

10. BID SECURITY

10.1. Bids must be accompanied by cash, a certified check, or cashier's check drawn on a bank in good standing, or a Bid bond issued by a Surety authorized to issue such bonds in the state where the work is located, in the amount of 5 percent of the total amount of the Bid submitted. This Bid security shall be given as a guarantee that the Bidder will not withdraw his Bid for a period of 180 days after Bid opening, and that if awarded the Contract, the successful Bidder will execute the attached Contract and furnish properly executed Performance and Payment Bonds, each in the full amount of the Contract price within the time specified.

10.2. The Attorney-in-Fact who executes this bond in behalf of the Surety must attach a notarized copy of his power-of-attorney as evidence of his authority to bind the Surety on the date of execution of the bond. Where State Statute requires, certification by a resident agent shall also be provided.

10.3. If the Bidder elects to furnish a Bid Bond, he shall use the Bid Bond form bound herewith, or one conforming substantially thereto in form and content.

11. RETURN OF BID SECURITY

11.1. Within 15 days after the award of the Contract, the Owner will return the Bid securities to all Bidders who's Bids are not to be further considered in awarding the Contract. Retained Bid securities will be held until the Contract has been finally executed, after which all Bid securities, other than Bidders' bonds and any guarantees which have been forfeited, will be returned to the respective Bidders whose Bids they accompanied.

12. AWARD OF CONTRACT

12.1. The Award will be made under one Contract by the Owner on the basis of the Bid from the lowest, responsive, responsible Bidder. The Owner may award entire Bid or selected line items based on the City's best interest and available funds at time of Award.

12.2. Within 90 calendar days after the opening of Bids, the Owner will accept one of the Bids or will act in accordance with the following paragraphs. The acceptance of the Bid will be by written notice of award, mailed to the office designated in the Bid, or delivered to the Bidder's representative. In the event of failure of the lowest responsive, responsible Bidder to sign the Contract and provide an acceptable Performance Bond, Payment Bond, insurance certificate(s) and evidence of holding required licenses and certificates, the Owner may award the Contract to the next lowest responsive, responsible Bidder. Such award, if made, will be made within 105 days after the opening of Bids. Bidders will guarantee their Bid price(s) for up to 105 calendar days after Bid opening.

12.3. The Owner reserves the right to accept or reject any or all Bids, and to waive any informalities and irregularities in said Bids.

13. EXECUTION OF CONTRACT

13.1. The successful Bidder shall, within 10 working days after receiving Notice of Award, sign and deliver to the Owner a Contract in the form hereto attached, together with the insurance certificate examples of the bonds as required in the Contract Documents and evidence of holding required licenses and certificates. Within 10 working days after receiving the signed Contract from the successful Bidder, the Owner's authorized agent will sign the Contract. Signature by both parties constitutes execution of the Contract.

14. CONTRACT BONDS

14.1. Performance and Payment Bonds: The successful Bidder shall file with the Owner, at the time of delivery of the signed Contract, a Performance Bond and Payment Bond on the form bound herewith, each in the full amount of the Contract price in accordance with the requirements of Florida Statutes Section 255.05 or Section 713.23, as applicable, as security for the faithful performance of the Contract and the payment of all persons supplying labor and materials for the construction of the work, and to cover all guarantees against defective workmanship or materials, or both, during the warranty period following the date of final acceptance of the work by the Owner. The Surety furnishing this bond shall have a sound financial standing and a record of service satisfactory to the Owner, shall be authorized to do business in the State of Florida, and shall be listed on the current U.S. Department of Treasury Circular Number 570, or amendments thereto in the Federal Register, of acceptable Sureties for federal projects.

14.2. Power-of-Attorney:

14.2.1.1. The Attorney-in-Fact (Resident Agent in state which work is being performed) who executes this Performance and Payment Bond in behalf of the Surety must attach a notarized copy of his power-of-attorney as evidence of his authority to bind the Surety on the date of execution of the bond.

14.2.1.2. All Contracts, Performance and Payment Bonds, and respective powers-of-attorney will have the same date.

15. FAILURE TO EXECUTE CONTRACT AND FURNISH BOND

15.1. The Bidder who has a Contract awarded to him and who fails to promptly and properly execute the Contract or furnish the required Bonds shall forfeit the Bid security that accompanied his Bid, and the Bid security shall be retained as liquidated damages by the Owner, and it is agreed that this said sum is a fair estimate of the amount of damages the Owner will sustain in case the Bidder fails to enter into a

Contract or furnish the required Bonds. Bid security deposited in the form of cash, a certified check, or cashier's check shall be subject to the same requirement as a Bid Bond.

16. TIME OF COMPLETION

16.1. The time of completion of the work to be performed under this Contract is the essence of the Contract. Delays and extensions of time may be allowed in accordance with the provisions stated in the General Conditions. The time allowed for the completion of the work authorized is stated in the Bid.

17. LOCAL PREFERENCE

17.1. City of Key West Policy of Local Preference is applied to Bids submitted by qualified local business, per City Code Section 02-798.

18. MANDATORY PRE-BID CONFERENCE

18.1. A mandatory Pre-Bid Conference will be held by the City of Key West on **September 3, 2015**. The meeting will take place at the Richard A. Heyman Environmental Protection Facility on Fleming Key, Trumbo Annex, Key West, Florida. **Meeting attendees shall assemble at the guard shelter parking lot beginning at 10:00 a.m. All attendees are required to obtain a day pass from the Navy. The day pass requires a vehicle inspection at the Boca Chica Commercial Gate during the hours of operation: 07:00 a.m. to 10:00 a.m., Monday through Friday.** The City of Key West requires attendance by all prospective Bidders. The purpose of the meeting will be to discuss particular requirements and answer questions of the prospective Bidders relative to completing this project. Bids from Bidders that do not attend this Pre-bid Conference will be considered non-responsive and not accepted for consideration of this work by the City of Key West.

END OF SECTION

NOTE TO BIDDER: Use preferably BLACK ink for completing this Bid form.

BID FORM

To: The City of Key West

Address: 3126 Flagler Avenue, Key West, Florida 33040

Project Title: ITB #15-018 Repair of the Administration Building Roof at
the Richard A. Heyman EPF

CH2M HILL Project No.: 650974

City of Key West Project No.: SE 1402

Bidder's person to contact for additional information on this Bid:

Company Name: _____

Contact Name: _____

Telephone: _____

1. BIDDER'S DECLARATION AND UNDERSTANDING

1.1. The undersigned, hereinafter called the Bidder, declares that the only persons or parties interested in this Bid are those named herein, that this Bid is, in all respects, fair and without fraud, that it is made without collusion with any official of the Owner, and that the Bid is made without any connection or collusion with any person submitting another Bid on this Contract.

1.2. The Bidder further declares that he has carefully examined the Contract Documents for the construction of the project, that he has personally inspected the site, that he has satisfied himself as to the quantities involved, including materials and equipment, and conditions of work involved, including the fact that the description of the quantities of work and materials, as included herein, is brief and is intended only to indicate the general nature of the Work and to identify the said quantities with the detailed requirements of the Contract Documents, and that this Bid is made according to the provisions and under the terms of the Contract Documents, which Documents are hereby made a part of this Bid.

1.3. The Bidder further agrees, as evidenced by signing the Bid, that if awarded a Contract, the Florida Trench Safety Act and applicable trench safety standards will be complied with.

2. CONTRACT EXECUTION AND BONDS

2.1. The Bidder agrees that if this Bid is accepted, he will, within 10 days, not including Sundays and legal holidays, after Notice of Award, sign the Contract in the form annexed hereto, and will at that time, deliver to the Owner examples of the Performance Bond and Payment Bond required herein, and evidence of holding required licenses and certificates, and will, to the extent of his Bid, furnish all machinery, tools, apparatus, and other means of construction and do the Work and furnish all the materials necessary to complete all work as specified or indicated in the Contract Documents.

3. CERTIFICATES OF INSURANCE

3.1. Bidder agrees to furnish the Owner, before commencing the Work under this Contract, the certificates of insurance as specified in these Documents.

4. START OF CONSTRUCTION AND CONTRACT COMPLETION TIMES

4.1. The Bidder agrees to begin work within 10 calendar days after the date of the Notice to Proceed and to achieve Substantial Completion within 120 calendar days for both roofs from the date when the Contract Times commence to run as provided in paragraph 2.03.A of the General Conditions, and Work will be completed and ready for final payment and acceptance in accordance with paragraph 14.07 of the General Conditions within 150 calendar days from the date when the Contract Times commence to run.

5. LIQUIDATED DAMAGES

5.1. In the event the Bidder is awarded the Contract, Owner and Bidder recognize that time is of the essence of this Agreement and that Owner will suffer financial loss if the Work is not completed within the times specified in paragraph Start of Construction and Contract Completion Times above, plus any extensions thereof allowed in accordance with Article 12 of the General Conditions. Owner and Bidder also recognize the delays, expense, and difficulties involved in proving in a legal or other dispute resolution proceeding the actual loss suffered by Owner if the Work is not completed on time. Accordingly, instead of requiring any such proof, Owner and Bidder agree that as liquidated damages for delay (but not as a penalty) Bidder shall pay Owner \$3,000.00 per day for each day that expires after the time specified for each substantial completion.

5.2. After Substantial Completion, if Bidder neglects, refuses, or fails to complete the remaining Work within the Contract Times or any Owner-granted extension thereof, Bidder shall pay Owner \$1,000.00 for each day that expires after the time specified in paragraph Start of Construction and Contract Completion Times, above for completion and readiness for final payment. Liquidated damages shall run concurrent.

5.3. Owner will recover such liquidated damages by deducting the amount owed from the final payment or any retainage held by Owner.

6. ADDENDA

6.1. The Bidder hereby acknowledges that he has received Addenda Nos. _____, _____, _____, _____, (Bidder shall insert No. of each Addendum received) and agrees that all addenda issued are hereby made part of the Contract Documents, and the Bidder further agrees that his Bid(s) includes all impacts resulting from said addenda.

7. SALES AND USE TAXES

7.1. The Bidder agrees that all federal, state, and local sales and use taxes are included in the stated Bid Prices for the Work. Cash allowances DO NOT include any sales and use tax. Equipment allowance includes taxes as shown in Equipment Suppliers' Bid.

8. PUBLIC ENTITY CRIMES

8.1. "A person or affiliate who has been placed on the convicted vendor list following a conviction for a public entity crime may not submit a bid on a contract to provide any goods or services to a public entity, may not submit a bid on a contract with a public entity for the construction or repair of a public building or public work, may not submit bids on leases of real property to a public entity, may not be awarded or perform work as a contractor, supplier, subcontractor, or consultant under a contract with any public entity and may not transact business with any public entity in excess of the threshold amount provided in Section 287.017, for Category Two for a period of 36 months from the date of being placed on the convicted vendor list."

9. LUMP SUM ITEMS

9.1. The Bidder further proposes to accept as full payment for the Work proposed herein the amounts computed under the provisions of the Contract Documents and based on the following lump sum amounts. The Bidder agrees that the lump sums represent a true measure of labor and materials required to perform the Work, including all allowances for overhead and profit for each type and unit of work called for in these Contract Documents.

Lump Sum Bid Price

A. Administration Building \$ _____

TOTAL BASE BID \$ _____
(Numerals)

_____ Dollars

(Amount written in words has precedence)

and _____ Cents

ADDITIVE ALTERNATE NO. 1

This alternative is for demolition of the existing roof systems, roof membrane, walk pad, metal flashing installations, removal and re0installation of the lightning protection and all Work associated with the construction of the Chlorine Building Roof at the Richard A. Heyman EPF as shown on the Drawings. The alternative includes all material, labor, equipment, and necessary appurtenances.

\$ _____

10. SUBCONTRACTORS

10.1. The Bidder further proposes that the following subcontracting firms or businesses will be awarded subcontracts for the following portions of the Work in the event that the Bidder is awarded the Contract:

Name

Street City State Zip

Name

Street City State Zip

Name

Street City State Zip

Name

Street

City

State

Zip

Surety

whose address is

Street

City

State

Zip

Bidder

The name of the Bidder submitting this Bid is _____

doing business at

Street

City

State

Zip

which is the address to which all communications concerned with this Bid and with the Contract shall be sent.

The names of the principal officers of the corporation submitting this Bid, or of the partnership, or of all persons interested in this Bid as principals are as follows:

If Sole Proprietor or Partnership

IN WITNESS hereto the undersigned has set his (its) hand this _____ day of _____, 20_____.

Signature of Bidder

Title

If Corporation

IN WITNESS WHEREOF the undersigned corporation has caused this instrument to be executed and its seal affixed by its duly authorized officers this __ day of _____, 20__.

(SEAL)

Name of Corporation

By: _____

Title: _____

Attest: _____
Secretary

END OF SECTION

FLORIDA BID BOND

BOND NO. _____

AMOUNT: \$ _____

KNOW ALL MEN BY THESE PRESENTS, that _____

_____ hereinafter called the Contractor (Principal), and _____

_____ a corporation duly organized and existing under and by virtue of the laws of the State of Florida, hereinafter called the Surety, and authorized to transact business within the State of Florida, as Surety, are held and firmly bound unto The City of Key West as Owner.

(Obligee), in the sum of: _____

_____ DOLLARS (\$ _____), for the payment for which we bind ourselves, our heirs, executors, administrators, successors, and assigns, jointly and severally, firmly by these presents.

THE CONDITION OF THIS BOND IS SUCH THAT:

WHEREAS, the Principal is herewith submitting his or its Bid Proposal for Repair of the Administration Building Roof at the Richard A. Heyman EPF, Key West, Florida, said Bid Proposal, by reference thereto, being hereby made a part hereof.

WHEREAS, the Principal contemplates submitting or has submitted a bid to the Obligee for the furnishing of all labor, materials (except those to be specifically furnished by the Owner), equipment, machinery, tools, apparatus, means of transportation for, and the performance of the work covered in the Proposal and the detailed Drawings and Specifications, entitled:

Repair of the Administration Building Roof at the Richard A. Heyman EPF

WHEREAS, it was a condition precedent to the submission of said bid that a cashier's check, certified check, or bid bond in the amount of 5 percent of the base bid be submitted with said bid as a guarantee that the Bidder would, if awarded the Contract, enter into a written Contract with the Owner for the performance of said Contract, within 10 working days after written notice having been given of the award of the Contract.

NOW, THEREFORE, the conditions of this obligation are such that if the Principal within 10 consecutive calendar days after written notice of such acceptance, enters into a written Contract with the Oblige and furnishes the Performance and Payment Bonds, each in an amount equal to 100 percent of the awarded base bid, satisfactory to the Owner, then this obligation shall be void; otherwise the sum herein stated shall be due and payable to the Oblige and the Surety herein agrees to pay said sum immediately upon demand of the Oblige in good and lawful money of the United States of America, as liquidated damages for failure thereof of said Principal.

Signed and sealed this _____ day of _____, 20_____.

Principal

By: _____

Surety

By: _____

Attorney-In-Fact

END OF SECTION

**SWORN STATEMENT UNDER SECTION 287.133(3)(A)
FLORIDA STATUTES, ON PUBLIC ENTITY CRIMES**

*THIS FORM MUST BE SIGNED IN THE PRESENCE OF A NOTARY PUBLIC OR OTHER OFFICER
AUTHORIZED TO ADMINISTER OATHS.*

1. This sworn statement is submitted with Bid or Proposal for Repair of the Administration Building Roof at the Richard A. Heyman EPF, City of Key West, Florida
2. This sworn statement is submitted by _____
(name of entity submitting sworn statement)

whose business address is _____

_____ and (if applicable) its Federal Employer
Identification Number (FEIN) is _____

(If the entity has no FEIN, include the Social Security Number of the individual signing this
sworn statement _____)
3. My name is _____
(please print name of individual signing)

and my relationship to the entity named above is _____
4. I understand that a "public entity crime" as defined in Paragraph 287.133(1)(g), Florida Statutes, means a violation of any state or federal law by a person with respect to and directly related to the transaction of business with any public entity or with an agency or political subdivision of any other state or with the United States, including but not limited to, any bid or contract for goods or services to be provided to any public or an agency or political subdivision of any other state or of the United States and involving antitrust, fraud, theft, bribery, collusion, racketeering, conspiracy, material misrepresentation.
5. I understand that "convicted" or "conviction" as defined in Paragraph 287.133(1)(b), Florida Statutes, means a finding of guilt or a conviction of a public entity crime, with or without an adjudication guilt, in any federal or state trial court of record relating to charges brought by indictment information after July 1, 1989, as a result of a jury verdict, nonjury trial, or entry of a plea of guilty or nolo contendere.
6. I understand that an "affiliate" as defined in Paragraph 287.133(1)(a), Florida Statutes, means
 1. A predecessor or successor of a person convicted of a public entity crime; or
 2. An entity under the control of any natural person who is active in the management of the entity and who has been convicted of a public entity crime. The term "affiliate" includes those officers, directors, executives, partners, shareholders, employees, members, and agents who are active in the management of an affiliate. The ownership by one person of shares constituting controlling interest in another person, or a pooling of equipment or income among persons when not for fair market value under an arm's length agreement, shall be a prima facie case that one person controls another person. A person who knowingly enters into a joint venture with a person who has been convicted of a public entity crime in Florida during the preceding 36 months shall be considered an affiliate.

- 7. I understand that a "person" as defined in Paragraph 287.133(1)(8), Florida Statutes, means any natural person or entity organized under the laws of any state or of the United States with the legal power to enter into a binding contract and which bids or applies to bid on contracts for the provision of goods or services let by a public entity, or which otherwise transacts or applies to transact business with public entity. The term "person" includes those officers, directors, executives, partners, shareholders, employees, members, and agents who are active in management of an entity.
- 8. Based on information and belief, the statement which I have marked below is true in relation to the entity submitting this sworn statement. (Please indicate which statement applies).

____ Neither the entity submitting this sworn statement, nor any officers, directors, executives, partners, shareholders, employees, members, or agents who are active in management of the entity, nor any affiliate of the entity have been charged with and convicted of a public entity crime subsequent to July 1, 1989, AND (Please indicate which additional statement applies.)

____ There has been a proceeding concerning the conviction before a hearing of the State of Florida, Division of Administrative Hearings. The final order entered by the hearing officer did not place the person or affiliate on the convicted vendor list. (Please attach a copy of the final order.)

____ The person or affiliate was placed on the convicted vendor list. There has been a subsequent proceeding before a hearing officer of the State of Florida, Division of Administrative Hearings. The final order entered by the hearing officer determined that it was in the public interest to remove the person or affiliate from the convicted vendor list. (Please attach a copy of the final order.)

____ The person or affiliate has not been put on the convicted vendor list. (Please describe any action taken by or pending with the Department of General Services.)

(signature)

(date)

STATE OF _____

COUNTY OF _____

PERSONALLY APPEARED BEFORE ME, the undersigned authority,

_____ who, after first being sworn by me, affixed his/her
(name of individual signing)

signature in the space provided above on this ____ of _____, 20____.

My commission expires:

NOTARY PUBLIC

CITY OF KEY WEST INDEMNIFICATION FORM

To the fullest extent permitted by law, the CONTRACTOR expressly agrees to indemnify and hold harmless the City of Key West, their officers, directors, agents and employees *(herein called the "indemnitees") from liabilities, damages, losses and costs, including but not limited to, reasonable attorney's fees and court costs, such legal expenses to include costs incurred in establishing the indemnification and other rights agreed to in this Paragraph, to persons or property, to the extent caused by the negligence, recklessness, or intentional wrongful misconduct of the CONTRACTOR, its Subcontractors or persons employed or utilized by them in the performance of the Contract. Claims by indemnitees for indemnification shall be limited to the amount of CONTRACTOR's insurance or \$1 million per occurrence, whichever is greater. The parties acknowledge that the amount of the indemnity required hereunder bears a reasonable commercial relationship to the Contract and it is part of the Project Specifications or the Bid Documents, if any.

The indemnification obligations under the Contract shall not be restricted in any way by any limitation on the amount or type of damages, compensation, or benefits payable by or for the CONTRACTOR under Workers' Compensation acts, disability benefits acts, or other employee benefits acts, and shall extend to and include any actions brought by or in the name of any employee of the CONTRACTOR or of any third party to whom CONTRACTOR may subcontract a part or all of the Work. This indemnification shall continue beyond the date of completion of the Work.

CONTRACTOR: _____

SEAL:

Address

Signature

Print Name

Title

DATE: _____

City Ordinance Sec. 2-799
Requirements for City Contractors to Provide Equal Benefits for Domestic Partners

(a) Definitions. For purposes of this section only, the following definitions shall apply:

- (1) **Benefits** means the following plan, program or policy provided or offered by a contractor to its employees as part of the employer's total compensation package: sick leave, bereavement leave, family medical leave, and health benefits.
- (2) **Bid** shall mean a competitive bid procedure established by the city through the issuance of an invitation to bid, request for proposals, request for qualifications, or request for letters of interest.
- (3) **Cash equivalent** means the amount of money paid to an employee with a domestic partner in lieu of providing benefits to the employee's domestic partner. The cash equivalent is equal to the employer's direct expense of providing benefits to an employee for his or her spouse.

The cash equivalents of the following benefits apply:

- a. For bereavement leave, cash payment for the number of days that would be allowed as paid time off for the death of a spouse. Cash payment would be in the form of the wages of the domestic partner employee for the number of days allowed.
 - b. For health benefits, the cost to the contractor of the contractor's share of the single monthly premiums that are being paid for the domestic partner employee, to be paid on a regular basis while the domestic partner employee maintains such insurance in force for himself or herself.
 - c. For family medical leave, cash payment for the number of days that would be allowed as time off for an employee to care for a spouse who has a serious health condition. Cash payment would be in the form of the wages of the domestic partner employee for the number of days allowed.
- (4) **Contract** means any written agreement, purchase order, standing order or similar instrument entered into pursuant to the award of a bid whereby the city is committed to expend or does expend funds in return for work, labor, professional services, consulting services, supplies, equipment, materials, construction, construction related services or any combination of the foregoing.
 - (5) **Contractor** means any person or persons, sole proprietorship, partnership, joint venture, corporation, or other form of doing business, that is awarded a bid and enters into a covered contract with the city, and which maintains five (5) or more full-time employees.
 - (6) **Covered contract** means a contract between the city and a contractor awarded subsequent to the date when this section becomes effective valued at over twenty thousand dollars (\$20,000).

- (7) ***Domestic partner*** shall mean any two adults of the same or different sex, who have registered as domestic partners with a governmental body pursuant to state or local law authorizing such registration, or with an internal registry maintained by the employer of at least one of the domestic partners. A contractor may institute an internal registry to allow for the provision of equal benefits to employees with domestic partner who do not register their partnerships pursuant to a governmental body authorizing such registration, or who are located in a jurisdiction where no such governmental domestic partnership registry exists. A contractor that institutes such registry shall not impose criteria for registration that are more stringent than those required for domestic partnership registration by the City of Key West pursuant to Chapter 38, Article V of the Key West Code of Ordinances.
- (8) ***Equal benefits*** mean the equality of benefits between employees with spouses and employees with domestic partners, and/or between spouses of employees and domestic partners of employees.
- (b) Equal benefits requirements.
- (1) Except where otherwise exempt or prohibited by law, a Contractor awarded a covered contract pursuant to a bid process shall provide benefits to domestic partners of its employees on the same basis as it provides benefits to employees' spouses.
 - (2) All bid requests for covered contracts which are issued on or after the effective date of this section shall include the requirement to provide equal benefits in the procurement specifications in accordance with this section.
 - (3) The city shall not enter into any covered contract unless the contractor certifies that such contractor does not discriminate in the provision of benefits between employees with domestic partners and employees with spouses and/or between the domestic partners and spouses of such employees.
 - (4) Such certification shall be in writing and shall be signed by an authorized officer of the contractor and delivered, along with a description of the contractor's employee benefits plan, to the city's procurement director prior to entering into such covered contract.
 - (5) The city manager or his/her designee shall reject a contractor's certification of compliance if he/she determines that such contractor discriminates in the provision of benefits or if the city manager or designee determines that the certification was created, or is being used for the purpose of evading the requirements of this section.

- (6) The contractor shall provide the city manager or his/her designee, access to its records for the purpose of audits and/or investigations to ascertain compliance with the provisions of this section, and upon request shall provide evidence that the contractor is in compliance with the provisions of this section upon each new bid, contract renewal, or when the city manager has received a complaint or has reason to believe the contractor may not be in compliance with the provisions of this section. This shall include but not be limited to providing the city manager or his/her designee with certified copies of all of the contractor's records pertaining to its benefits policies and its employment policies and practices.
 - (7) The contractor may not set up or use its contracting entity for the purpose of evading the requirements imposed by this section.
- (c) Mandatory contract provisions pertaining to equal benefits. Unless otherwise exempt, every covered contract shall contain language that obligates the contractor to comply with the applicable provisions of this section. The language shall include provisions for the following:
- (1) During the performance of the covered contract, the contractor certifies and represents that it will comply with this section.
 - (2) The failure of the contractor to comply with this section will be deemed to be a material breach of the covered contract.
 - (3) If the contractor fails to comply with this section, the city may terminate the covered contract and all monies due or to become due under the covered contract may be retained by the city. The city may also pursue any and all other remedies at law or in equity for any breach.
 - (4) If the city manager or his designee determines that a contractor has set up or used its contracting entity for the purpose of evading the requirements of this section, the city may terminate the covered contract.
- (d) Enforcement. If the contractor fails to comply with the provisions of this section:
- (1) The failure to comply may be deemed to be a material breach of the covered contract; or
 - (2) The city may terminate the covered contract; or
 - (3) Monies due or to become due under the covered contract may be retained by the city until compliance is achieved; or
 - (4) The city may also pursue any and all other remedies at law or in equity for any breach;
 - (5) Failure to comply with this section may also subject contractor to the procedures set forth in Division 5 of this article, entitled "Debarment of contractors from city work."

(e) Exceptions and waivers.

The provisions of this section shall not apply where:

- (1) The contractor does not provide benefits to employees' spouses.
- (2) The contractor is a religious organization, association, society or any non-profit charitable or educational institution or organization operated, supervised or controlled by or in conjunction with a religious organization, association or society.
- (3) The contractor is a governmental entity.
- (4) The sale or lease of city property.
- (5) The provision of this section would violate grant requirement, the laws, rules or regulations of federal or state law (for example, The acquisition services procured pursuant to Chapter 287.055, Florida Statutes known as the "Consultants' Competitive Negotiation Act").
- (6) Provided that the contractor does not discriminate in the provision of benefits, a contractor may also comply with this section by providing an employee with the cash equivalent of such benefits, if the city manager or his/her designee determines that either:
 - a. The contractor has made a reasonable yet unsuccessful effort to provide equal benefits. The contractor shall provide the city manager or his/her designee with sufficient proof of such inability to provide such benefit or benefits which shall include the measures taken to provide such benefits or benefits and the cash equivalent proposed, along with its certificate of compliance, as is required under this section.
- (7) The city commission waives compliance of this section in the best interest of the city, including but not limited to the following circumstances:
 - a. The covered contract is necessary to respond to an emergency.
 - b. Where only one bid response is received.
 - c. Where more than one bid response is received, but the bids demonstrate that none of the bidders can comply with the requirements of this section.
- (f) City's authority to cancel contract. Nothing in this section shall be construed to limit the city's authority to cancel or terminate a contract, deny or withdraw approval to perform a subcontract or provide supplies, issue a non-responsibility finding, issue a non-responsiveness finding, deny a person or entity prequalification, or otherwise deny a person or entity city business.
- (g) Timing of application. This section shall be applicable only to covered contracts awarded pursuant to bids which are after the date when this section becomes effective.

CITY OF KEY WEST BUSINESS LICENSE TAX RECEIPT

1. A City of Key West Business License Tax Receipt is required for this Project. Contractor must be general contractor or building contractor or engineering contractor. Fee not to exceed \$309.75.

2. A City of Key West Business License Tax Receipt also is required as for sub-contracting landscaping contractor, engineering services, and professional surveying.

3. A Business License Tax Application can be found on the City's web site.

<http://www.keywestcity.com/egov/docs/1162843921181.htm>

Business License Tax Application

City of Key West
City Hall Annex
PO Box 1409
Key West, FL 33041

Date Applied _____

License # _____

Phone 305-809-3955
Fax 305-809-3978

Business Type: _____

Business Name: _____

Business Location: _____

Business Owner: _____

State Licensed Qualifier (if applicable): _____

Mailing Address: _____

EIN / SS # _____ Phone # _____

Applicant name (printed)

Applicant signature

Date

State of Florida
County of Monroe

The foregoing instrument was acknowledged before me this ____ day of _____, 20____, by _____.

Signature of Notary Public (stamp or seal). Personally known ____
Produced id _____

____ Sales Tax number 3106 Flagler Ave 292-6735 City utility acct _____

____ Commercial garbage Waste Mgmt 296-8297 _____

____ Lease or deed

____ State License DBPR 850-487-1395 / Dept Ag 305-470-6900

____ Home occupation application

____ Fictitious Name registration Previous use _____

____ Corporate or LLC registration

____ Liability / Worker's Comp Zoning _____

____ Fire Inspector 292-8179

____ CO / final inspection on any permits Category _____ Fee \$ _____

____ Monroe County or local licensing

Licensed in accordance with Chapter 66, Key West Code of Ordinances

____ Approved _____ Denied / Reason _____

Licensing Official

Date

CONE OF SILENCE AFFIDAVIT

STATE OF _____)
: SS
COUNTY OF _____)

I the undersigned hereby duly sworn depose and say that all owner(s), partners, officers, directors, employees and agents representing the firm of _____ have read and understand the limitations and procedures regarding communications concerning City of Key West issued competitive solicitations pursuant to City of Key West Ordinance Section 2-773 Cone of Silence (attached).

Sworn and subscribed before me this

_____ day of _____, 20__.

NOTARY PUBLIC, State of _____ at Large

My Commission Expires: _____

Sec. 2-773. Cone of Silence

(a) Definitions. For purposes of this section, reference to one gender shall include the other, use of the plural shall include the singular, and use of the singular shall include the plural. The following definitions apply unless the context in which the word or phrase is used requires a different definition:

- 1) *Competitive Solicitation* means a formal process by the City of Key West relating to the acquisition of goods or services, which process is intended to provide an equal and open opportunity to qualified persons and entities to be selected to provide the goods or services. Competitive Solicitation shall include request for proposals ("RFP"), request for qualifications ("RFQ"), request for letters of interest ("RFLI"), invitation to bid ("ITB") or any other advertised solicitation.
- 2) *Cone of Silence* means a period of time during which there is a prohibition on communication regarding a particular Competitive Solicitation.
- 3) *Evaluation or Selection Committee* means a group of persons appointed or designated by the City to evaluate, rank, select, or make a recommendation regarding a Vendor or the Vendor's response to the Competitive Solicitation. A member of such a committee shall be deemed a city official for the purposes of subsection (c) below.
- 4) *Vendor* means a person or entity that has entered into or that desires to enter into a contract with the City of Key West or that seeks an award from the City to provide goods, perform a service, render an opinion or advice, or make a recommendation related to a Competitive Solicitation for compensation or other consideration.
- 5) *Vendor's Representative* means an owner, individual, employee, partner, officer, or member of the board of directors of a Vendor, or a consultant, lobbyist, or actual or potential subcontractor or sub consultant who acts at the behest of a Vendor in communicating regarding a Competitive Solicitation.

(b) Prohibited Communications: A Cone of Silence shall be in effect during the course of a Competitive Solicitation and prohibit:

- 1) Any communication regarding a particular Competitive Solicitation between a potential Vendor or Vendor's Representative and the City's administrative staff including, but not limited to, the city manager and his or her staff;
- 2) Any communication regarding a particular Competitive Solicitation between a potential Vendor or Vendor's Representative and the Mayor, City Commissioners, or their respective staff;

- 3) Any communication regarding a particular Competitive Solicitation between a potential Vendor or Vendor's Representative and any member of a City evaluation and/or selection committee therefore; and
- 4) Any communication regarding a particular Competitive Solicitation between the Mayor, City Commissioners, or their respective staff, and a member of a City evaluation and/or selection committee therefore.

(c) Permitted Communications: Notwithstanding the foregoing, nothing contained herein shall prohibit:

- 1) Communication between members of the public who are not Vendors or a Vendor's representative and any city employee, official or member of the City Commission;
- 2) Communications in writing at any time with any city employee, official or member of the City Commission, unless specifically prohibited by the applicable Competitive Solicitation.

(A) However, any written communication must be filed with the City Clerk. Any City employee, official or member of the City Commission receiving or making any written communication must immediately file it with the City Clerk.

(B) The City Clerk shall include all written communication as part of the agenda item when publishing information related to a particular Competitive Solicitation.

- 3) Oral communications at duly noticed pre-bid conferences;
- 4) Oral presentations before publically noticed evaluation and/or selection committees;
- 5) Contract discussions during any duly noticed public meeting;
- 6) Public presentations made to the City Commission or advisory body thereof during any duly noticed public meeting;
- 7) Contract negotiations with city staff following the award of a Competitive Solicitation by the City Commission; or
- 8) Purchases exempt from the competitive process pursuant to section 2-797 of these Code of Ordinances.

(d) Procedure

- 1) The Cone of Silence shall be imposed upon each Competitive Solicitation at the time of Public Notice of such solicitation as provided by section 2-826 of this Code. Public notice of the Cone of Silence shall be included in the notice of the Competitive Solicitation. The city manager shall issue a written notice of the release of each Competitive Solicitation to the affected departments, with a copy thereof to each Commission member, and shall include in any public solicitation for goods and services a statement disclosing the requirements of this ordinance.
- 2) The Cone of Silence shall terminate at the time the City Commission or other authorized body makes final award or gives final approval of a contract, rejects all bids or responses to the Competitive Solicitation, or takes other action which ends the Competitive Solicitation.
- 3) Any City employee, official or member of the City Commission that is approached concerning a Competitive Solicitation while the Cone of Silence is in effect shall notify such individual of the prohibitions contained in this section. While the Cone of Silence is in effect, any City employee, official or member of the City Commission who is the recipient of any oral communication by a potential Vendor or Vendor's Representative in violation of this section shall create a written record of the event. The record shall indicate the date of such communication, the persons with whom such communication occurred, and a general summation of the communication.

(e) Violations/penalties and procedures.

- 1) A sworn complaint alleging a violation of this ordinance may be filed with the City Attorney's office. In each such instance, an initial investigation shall be performed to determine the existence of a violation. If a violation is found to exist, the penalties and process shall be as provided in section 1-15 of this Code.
- 2) In addition to the penalties described herein and otherwise provided by law, a violation of this ordinance shall render the Competitive Solicitation void at the discretion of the City Commission.
- 3) Any person who violates a provision of this section shall be prohibited from serving on a City of Key West advisory board, evaluation and/or selection committee.
- 4) In addition to any other penalty provided by law, violation of any provision of this ordinance by a City of Key West employee shall subject said employee to disciplinary action up to and including dismissal.

- 5) If a Vendor is determined to have violated the provisions of this section on two more occasions it shall constitute evidence under City Code section 2-834 that the Vendor is not properly qualified to carry out the obligations or to complete the work contemplated by any new Competitive Solicitation. The City's Purchasing Agent shall also commence any available debarment from city work proceeding that may be available upon a finding of two or more violations by a Vendor of this section.

**LOCAL VENDOR CERTIFICATION PURSUANT TO CKW ORDINANCE 09-22
SECTION 2-798**

The undersigned, as a duly authorized representative of the vendor listed herein, certifies to the best of his/her knowledge and belief, that the vendor meets the definition of a "Local Business." For purposes of this section, "local business" shall mean a business which:

- a. Principle address as registered with the FL Department of State located within 30 miles of the boundaries of the city, listed with the chief licensing official as having a business tax receipt with its principle address within 30 miles of the boundaries of the city for at least one year immediately prior to the issuance of the solicitation.
- b. Maintains a workforce of at least 50 percent of its employees from the city or within 30 miles of its boundaries.
- c. Having paid all current license taxes and any other fees due the city at least 24 hours prior to the publication of the call for bids or request for proposals.
 - Not a local vendor pursuant to Ordinance 09-22 Section 2-798
 - Qualifies as a local vendor pursuant to Ordinance 09-22 Section 2-798

If you qualify, please complete the following in support of the self certification & submit copies of your County and City business licenses. Failure to provide the information requested will result in denial of certification as a local business.

Business Name

Phone:

Current Local Address:
(P.O Box numbers may not be used to establish status)

Fax:

Length of time at this address

Signature of Authorized Representative

Date

STATE OF _____
COUNTY OF _____

The foregoing instrument was acknowledged before me this _____ day of _____, 20__.

By _____, of _____
(Name of officer or agent, title of officer or agent) Name of corporation acknowledging)
or has produced _____ as identification
(type of identification)

Signature of Notary

Print, Type or Stamp Name of Notary

Title or Rank

Return Completed form with
Supporting documents to:
City of Key West Purchasing

BIDDER'S CHECKLIST

(Note: The purpose of this checklist is to serve as a reminder of major items to be addressed in submitting a Bid and is not intended to be all inclusive. It does not alleviate the Bidder from the responsibility of becoming familiar with all aspects of the Contract Documents and proper completion and submission of their Bid.)

- | | |
|--|-----|
| 1. All Contract Documents thoroughly read and understood. | [] |
| 2. All blank spaces in Bid Form filled in, using black ink. | [] |
| 3. Total and unit prices added correctly. | [] |
| 4. Addenda acknowledged. | [] |
| 5. Subcontractors are named as indicated in the Bid Form. | [] |
| 6. Experience record included. | [] |
| 7. Bid signed by authorized officer. | [] |
| 8. Bid Bond completed and executed, including power-of-attorney dated the same date as Bid Bond. | [] |
| 9. Bidder familiar with federal, state, and local laws, ordinances, rules and regulations affecting performance of the work. | [] |
| 10. Bidder, if successful, able to obtain and/or demonstrate possession of required licenses and certificates within (10) ten calendar days after receiving a Notice of Award. | [] |
| 11. Bid submitted intact with the volume containing the Bidding Requirements, Contract Forms, and Conditions of the Contract and two copies. | [] |
| 12. Bid Documents submitted in sealed envelope and addressed and labeled in conformance with the instructions in the Invitation to Bid. | [] |
| 13. Bidder must provide satisfactory documentation of State Licenses. | [] |

END OF SECTION

DISCLOSURE OF LOBBYING ACTIVITIES

Complete this form to disclose lobbying activities pursuant to 31 U.S.C. 1352
(See reverse for public burden disclosure.)

<p>1. Type of Federal Action:</p> <input type="checkbox"/> a. contract b. grant c. cooperative agreement d. loan e. loan guarantee f. loan insurance	<p>2. Status of Federal Action:</p> <input type="checkbox"/> a. bid/offer/application b. initial award c. post-award	<p>3. Report Type:</p> <input type="checkbox"/> a. initial filing b. material change
<p>4. Name and Address of Reporting Entity:</p> <input type="checkbox"/> Prime <input type="checkbox"/> Subawardee Tier _____, <i>if known:</i> <p>Congressional District, if known:</p>		<p>5. If Reporting Entity in No. 4 is Subawardee, Enter Name and Address of Prime:</p> <p>Congressional District, if known:</p>
<p>6. Federal Department/Agency:</p>	<p>7. Federal Program Name/Description:</p> <p>CFDA Number, <i>if applicable:</i></p> <hr/>	
<p>8. Federal Action Number, if known:</p>	<p>9. Award Amount, if known:</p> <p>\$</p>	

<p>10. a. Name and Address of Lobbying Entity <i>(if individual, last name, first name, MI):</i></p> <p style="text-align: center;"><i>(attach Continuation Sheet(s))</i></p>	<p>b. Individuals Performing Services <i>(including address if different from No. 10a)</i> <i>(last name, first name, MI):</i></p> <p style="text-align: center;"><i>SF-LLLA, if necessary)</i></p>
<p>11. Information requested through this form is authorized by title 31 U.S.C. section 1352. This disclosure of lobbying activities is a material representation of fact upon which reliance was placed by the tier above when this transaction was made or entered into. This disclosure is required pursuant to 31 U.S.C. 1352. This information will be reported to Congress semi-annually and will be available for public inspection. Any person who fails to file the required disclosure shall be subject to a civil penalty of not less than \$10,000 and not more than \$100,000 for each such failure.</p>	<p>Signature: _____ _____</p> <p>Print Name: _____ _____</p> <p>Title: _____ _____</p> <p>Telephone No.: _____ Date: _____ _____</p>
<p>Federal Use Only:</p>	<p>Authorized for Local Reproduction Standard Form – LLL (Rev 7 – 97)</p>

FORM DEP 55-221 (01/01)

INSTRUCTIONS FOR COMPLETION OF SF-LLL, DISCLOSURE OF LOBBYING ACTIVITIES

This disclosure form shall be completed by the reporting entity, whether subawardee or prime Federal recipient, at the initiation or receipt of a covered Federal action, or a material change to a previous filing, pursuant to title 31 U.S.C. section 1352. The filing of a form is required for each payment or agreement to make payment to any lobbying entity for influencing or attempting to influence an officer or employee of any agency, a Member of Congress, an officer or employee of Congress, or an employee of a Member of Congress in connection with a covered Federal action. Complete all items that apply for both the initial filing and material change report. Refer to the implementing guidance published by the Office of Management and Budget for additional information.

- 1. Identify the type of covered Federal action for which lobbying activity is and/or has been secured to influence the outcome of a covered Federal action.**
- 2. Identify the status of the covered Federal action.**
- 3. Identify the appropriate classification of this report. If this is a follow up report caused by a material change to the information previously reported, enter the year and quarter in which the change occurred. Enter the date of the last previously submitted report by the reporting entity for this covered Federal action.**
- 4. Enter the full name, address, city, state and zip code of the reporting entity. Include Congressional District, if known. Check the appropriate classification of the reporting entity that designates if it is or expects to be, a prime or subaward recipient. Identify the tier of the subawardee, e.g., the first subawardee of the prime is the 1st tier. Subawards include but are not limited to subcontracts, subgrants and contract awards under grants.**
- 5. If the organization filing the report in item 4 checks "Subawardee", then enter the full name, address, city, state and zip code of the prime Federal recipient. Include Congressional District, if known.**
- 6. Enter the name of the Federal agency making the award or loan commitment. Include at least one organizational level below agency name, if known. For example, Department of Transportation, United States Coast Guard.**
- 7. Enter the Federal program name or description for the covered Federal action (item 1). If known, enter the full Catalog of Federal Domestic Assistance (CFDA) number for grants, cooperative agreements, loans, and loan commitments.**

8. Enter the most appropriate Federal identifying number available for the Federal action identified in item 1 (e.g., Request for Proposal (RFP) number; Invitation for Bid (IFB) number; grant announcement number; the contract, grant, or loan award number; the application/proposal control number assigned by the Federal agency). Include prefixes, e.g., "RFP-DE-90-001."
9. For a covered Federal action where there has been an award or loan commitment by the Federal agency, enter the Federal amount of the award/loan commitment for the prime entity identified in item 4 or 5.
10. (a) Enter the full name, address, city, state and zip code of the lobbying entity engaged by the reporting entity identified in item 4 to influence the covered Federal action.

(b) Enter the full names of the individual(s) performing services, and include full address if different from 10 (a). Enter Last Name, First Name, and Middle Initial (MI).
11. The certifying official shall sign and date the form, print his/her name, title and telephone number.

According to the Paperwork Reduction Act, as amended, no persons are required to respond to a collection of information unless it displays a valid OMB Control Number. The valid OMB control number for this information collection is OMB No. 0348-0046. Public reporting burden for this collection of information is estimated to average 30 minutes per response, including time for reviewing instructions, searching existing data sources, gathering and maintaining the data needed, and completing and reviewing the collection of information. Send comments regarding the burden estimate or any other aspect of this collection of information, including suggestions for reducing this burden, to the Office of Management and Budget, Paperwork Reduction Project (0348-0046), Washington, D.C. 20503.

Form DEP 55-221 (01/01)

NON-COLLUSION DECLARATION AND COMPLIANCE WITH 49 CFR §29.

ITEM/SEGMENT NO.: _____
F.A.P. NO.: _____
PARCEL NO.: _____
COUNTY OF: _____
BID LETTING OF: _____, _____

I, _____, hereby
(NAME)
declare that I am _____ of _____
(TITLE) (FIRM)
Of _____
(CITY AND STATE)

and that I am the person responsible within my firm for the final decision as to the price(s) and amount of this Bid on this State Project.

I further declare that:

- 1. The prices(s) and amount of this bid have been arrived at independently, without consultation, communication or agreement, for the purpose of restricting competition with any other contractor, bidder or potential bidder.
- 2. Neither the price(s) nor the amount of this bid have been disclosed to any other firm or person who is a bidder or potential bidder on this project, and will not be so disclosed prior to the bid opening.
- 3. No attempt has been made or will be made to solicit, cause or induce any other firm or person to refrain from bidding on this project, or to submit a bid higher than the bid of this firm, or any intentionally high or non-competitive bid or other form of complementary bid.
- 4. The bid of my firm is made in good faith and not pursuant to any agreement or discussion with, or inducement from, any firm or person to submit a complementary bid.
- 5. My firm has not offered or entered into a subcontract or agreement regarding the purchase of materials or services from any firm or person, or offered, promised or paid cash or anything of value to any firm or person, whether in connection with this or any other project, in consideration for an agreement or promise by any firm or person to refrain from bidding or to submit a complementary bid on this project.
- 6. My firm has not accepted or been promised any subcontract or agreement regarding the sale of materials or services to any firm or person, and has not been promised or paid cash or anything of value by any firm or person, whether in connection with this or any other project, in consideration for my firm's submitting a complementary bid, or agreeing to do so, on this project.
- 7. I have made a diligent inquiry of all members, officers, employees, and agents of my firm with responsibilities relating to the preparation, approval or submission of my firm's bid on this project and have been advised by each of them that he or she has not participated in any communication, consultation, discussion, agreement, collusion, act or other conduct inconsistent with any of the statements and representations made in this Declaration.

8. As required by Section 337.165, Florida Statutes, the firm has fully informed the Department of Transportation in writing of all convictions of the firm, its affiliates (as defined in Section 337.165(l)(a), Florida Statutes), and all directors, officers, and employees of the firm and its affiliates for violation of state or federal antitrust laws with respect to a public contract or for violation of any state or federal law involving fraud, bribery, collusion, conspiracy or material misrepresentation with respect to a public contract. This includes disclosure of the names of current employees of the firm or affiliates who were convicted of contract crimes while in the employ of another company.

9. I certify that, except as noted below, neither my firm nor any person associated therewith in the capacity of owner, partner, director, officer, principal, investigator, project director, manager, auditor, and/or position involving the administration of Federal funds:

(a) is presently debarred, suspended, proposed for debarment, declared ineligible, or voluntarily excluded from covered transactions, as defined in 49 CFR §29.110(a), by any Federal department or agency;

(b) has within a three-year period preceding this certification been convicted of or had a civil judgment rendered against him or her for: commission of fraud or a criminal offense in connection with obtaining, attempting to obtain, or performing a Federal, State or local government transaction or public contract; violation of Federal or State antitrust statutes; or commission of embezzlement, theft, forgery, bribery, falsification or destruction of records, making false statements or receiving stolen property;

(c) is presently indicted for or otherwise criminally or civilly charged by a Federal, State or local governmental entity with commission of any of the offenses enumerated in paragraph 9(b) of this certification; and

(d) has within a three-year period preceding this certification had one or more Federal, State or local government public transactions terminated for cause or default..

10. I(We), certify that I(We), shall not knowingly enter into any transaction with any subcontractor, material supplier, or vendor who is debarred, suspended, declared ineligible, or voluntarily excluded from participation in this contract by any Federal Agency unless authorized by the Department.

Where I am unable to declare or certify as to any of the statements contained in the above stated paragraphs numbered (1) through (10), I have provided an explanation in the "Exceptions" portion below or by attached separate sheet.

EXCEPTIONS: (Any exception listed above will not necessarily result in denial of award, but will be considered in determining bidder responsibility. For any exception noted, indicate to whom it applies, initiating agency and dates of agency action.

Providing false information may result in criminal prosecution and/or administrative sanctions.)

I declare under penalty of perjury that the foregoing is true and correct.

CONTRACTOR: _____ (Seal)

BY: _____ WITNESS: _____
NAME AND TITLE PRINTED

BY: _____ WITNESS: _____
SIGNATURE

Executed on this _____ day of _____, _____

***FAILURE TO FULLY COMPLETE AND EXECUTE THIS DOCUMENT
MAY RESULT IN THE BID BEING DECLARED NONRESPONSIVE***

SUSPENSION AND DEBARMENT CERTIFICATION

CERTIFICATION REGARDING DEBARMENTS, SUSPENSION, INELIGIBILITY AND VOLUNTARY EXCLUSION-LOWER TIER FEDERALLY FUNDED TRANSACTIONS

1. The undersigned hereby certifies that neither it nor its principals is presently debarred, suspended, proposed for debarment, declared ineligible, or voluntarily excluded from participation in this transaction by any Federal department or agency.

2. The undersigned also certifies that it and its principals:

(a) Have not within a three-year period preceding this certification been convicted of or had a civil judgment rendered

against them for commission of fraud or a criminal offense in connection with obtaining, attempting to obtain, or performing a public (Federal, State or local) transaction or contract under a public transaction; violation of Federal or State anti-trust statutes or commission of embezzlement, theft, forgery, bribery, falsification or destruction of records, making false statements, or receiving stolen property.

(b) Are not presently indicted for or otherwise criminally or civilly charged by a governmental entity (Federal, State or local) with commission of any of the offenses enumerated in paragraph 2.(a) of this Certification; and

(c) Have not within a three-year period preceding this certification had one or more public transactions (Federal, State or local) terminated for cause or default.

3. Where the undersigned is unable to certify to any of the statements in this certification, an explanation shall be attached to this certification.

Dated this day of, 20 .

By _____

Authorized Signature/Contractor

Typed Name/Title

Contractor's Firm Name

Street Address

Building, Suite Number

City/State/Zip Code

Area Code/Telephone Number

650974

PART 2

CONTRACTING REQUIREMENTS

AGREEMENT

This Agreement, made and entered into this _____ day of _____, 20_____.

by and between the City of Key West, hereinafter called the "Owner," and
 _____ hereinafter called the "Contractor."

WITNESSETH:

The Contractor, in consideration of the sum to be paid him by the Owner and of the covenants and agreements herein contained, hereby agrees at his own proper cost and expense to do all the work and furnish all the materials, tools, labor, and all appliances, machinery, and appurtenances for Construction of the "Repair of the Administration Building Roof at the Richard A. Heyman Environmental Protection Facility," to the extent of the Bid made by the Contractor, dated the _____ day of _____, 20_____, all in full compliance with the Contract Documents referred to herein.

The BIDDING REQUIREMENTS, including the signed copy of the Bid, the CONTRACT FORMS, the CONDITIONS OF THE CONTRACT, the SPECIFICATIONS, and the DRAWINGS, for "Repair of the Administration Building Roof at the Richard A. Heyman Environmental Protection Facility," dated _____, 20_____, are hereby referred to and by reference made a part of this Contract as fully and completely as if the same were fully set forth herein and are mutually cooperative therewith.

In consideration of the performance of the Work as set forth in these Contract Documents, the Owner agrees to pay to the Contractor the amount bid in the Bid as adjusted in accordance with the Contract Documents, or as otherwise herein provided, and to make such payments in the manner and at the times provided in the Contract Documents.

The Contractor agrees to complete the Work within the time specified and to accept as full payment hereunder the amounts computed as determined by the Contract Documents and based on the said Bid.

The Contractor agrees to remedy all defects appearing in the work or developing in the materials furnished and the workmanship performed under this Contract during the warranty period after the date of final acceptance of the Work by the Owner, and further agrees to indemnify and save the Owner harmless from any costs encountered in remedying such defects.

It is agreed that the Project, based upon the Bid, shall be substantially complete within 90 consecutive calendar days from the date the Notice to Proceed is issued, and will be totally completed and ready for final payment and acceptance within 120 consecutive calendar days from the date the Notice to Proceed is issued.

Liquidated Damages: The Contractor recognizes that time is of the essence and that the Owner will suffer financial loss if the Work is not completed within the times specified in paragraph above, plus any extensions thereof allowed in accordance with Article 12, of the General Conditions.

Owner and Contractor also recognize the delays, expense and difficulties involved in proving in a legal proceeding the actual loss suffered by the Owner, if the Work is not completed on time. Accordingly, instead of requiring any such proof, the Owner and Contractor agree that as liquidated damages for delay (but not as a penalty) Contractor shall pay the Owner (\$3,000.00) for each day that expires after the time specified for each substantial completion. After Substantial Completion if Contractor shall neglect, refuse or fail to complete the remaining Work within the Contract time or any proper extension thereof granted by the Owner, Contractor shall pay the Owner (\$1,000.00) for each day that expires after the time specified for completion and readiness for final payment. Liquidated damages shall run concurrent.

IN WITNESS WHEREOF, we, the parties hereto, each herewith subscribe the same this _____ day of _____, A.D., 20_____.

CITY OF KEY WEST

By: _____

Title: _____

Contractor:

By: _____

Title: _____

Approved as to Form

Attorney for Owner

END OF SECTION

PERFORMANCE BOND

BOND NO. _____

AMOUNT: \$ _____

KNOW ALL MEN BY THESE PRESENTS, that in accordance with Florida Statutes Section 255.05, _____ with offices at _____ hereinafter called the Contractor (Principal), and

_____ with offices at _____

a corporation duly organized and existing under and by virtue of the laws of the State of Florida, hereinafter called the Surety, and authorized to transact business within the State of Florida, as Surety, are held and firmly bound unto **CITY OF KEY WEST**, represented by its _____, hereinafter called the City (Obligee), in the sum of:

_____ DOLLARS (\$), lawful money of the United States of America, for the payment of which, well and truly be made to the City, the Contractor and the Surety bind themselves and each of their heirs, executors, administrators, successors, and assigns, jointly and severally, firmly by these presents as follows:

THE CONDITION OF THE ABOVE OBLIGATION IS SUCH THAT:

WHEREAS, the Contractor has executed and entered into the “Repair of the Administration Building Roof at the Richard A. Heyman Environmental Protection Facility” Contract hereto attached, with the City, dated _____, 20____, to furnish at their own cost, charges, and expense all the necessary materials, equipment, and/or labor in strict and express accordance with said Contract and the Contract Documents as defined therein, all of which is made a part of said Contract by certain terms and conditions in said Contract more particularly mentioned, which Contract, consisting of the various Contract Documents is made a part of this Bond as fully and completely as if said Contract Documents were set forth herein;

NOW THEREFORE, the conditions of this obligation are such that if the above bounden Contractor:

- 1. Shall in all respects comply with the terms and conditions of said Contract and his obligation there under, including the Contract Documents (which include the plans, drawings, specifications, and conditions as prepared by the City, invitation to bid, instructions to bidders, the Contractor’s bid as accepted by the above City, the bid and contract performance and payment bonds, and all addenda, if any, issued prior to the opening of bids), being made a part of this bond by reference, at the times and in the manner prescribed in the contract; and

2. Promptly makes payments to all claimants, as defined in Section 255.05(1), Florida Statutes, supplying Principal with labor, materials, or supplies, used directly or indirectly by Principal in the prosecution of the work provided for in the contract; and

3. Pays City all losses, costs, expenses, damages, attorney's fees, including appellate proceedings, injury or loss of whatever kind and however arising including, without limitation, delay damages to which said City may be subject by reason of any wrongdoing, misconduct, want of care or skill, negligence, failure of performance, breach, failure to petition within the prescribed time, or default, including patent infringements, on the part of said Contractor, his agents or employees, in the execution or performance of said Contract; and

4. Performs the guarantee of all work and materials furnished under the contract for the time specified in the contract, then this obligation shall be void; otherwise, to remain in full force and effect for the term of said Contract.

AND, the said Surety for value received, hereby stipulates and agrees that no change involving any extension of time, or addition to the terms of the Contract Documents, or to the work to be performed, or materials to be furnished there under shall affect said obligation of said Surety on this Bond, and the said Surety does hereby waive notice of any such changes, extension of time, alterations, or additions of the terms of the Contract Documents, or to the Work.

Any action instituted by a claimant under this bond for payment must be in accordance with the notice and time limitation provisions in Section 255.05(2), Florida Statutes.

IN WITNESS WHEREOF, the above parties bonded together have executed this instrument this _____ day of _____, 20____, the name and corporate seal of each corporate party being hereto affixed and those presents duly signed by its undersigned representative, pursuant to authority of its governing body.

CONTRACTOR

By: _____ (SEAL)

ATTEST

SURETY

By: _____ (SEAL)

ATTEST

END OF SECTION

PAYMENT BOND

BOND NO. _____

AMOUNT: \$ _____

KNOW ALL MEN BY THESE PRESENTS, that in accordance with Florida Statutes Section 255.05, _____

with offices at _____ hereinafter called the Contractor, (Principal), and _____

with offices at _____

a corporation duly organized and existing under and by virtue of the laws of the State of _____, hereinafter called the Surety, and authorized to transact business within the State of Florida, as Surety, are held and firmly bound City of Key West, represented by its _____, hereinafter called the City (Obligee), in the sum of: DOLLARS (\$), lawful money of the United States of America, for the payment of which, well and truly be made to the City, and the Contractor and the Surety bind themselves and each of their heirs, executors, administrators, successors, and assigns, jointly and severally, firmly by these presents as follows:

THE CONDITION OF THE ABOVE OBLIGATION IS SUCH THAT:

WHEREAS, the Contractor has executed and entered into a certain Contract for the “Repair of the Administration Building Roof at the Richard A. Heyman Environmental Protection Facility” attached hereto, with the City, dated _____, 20_____, to furnish at their own cost, charges, and expense the necessary materials, equipment, and/or labor in strict and express accordance with said Contract and the plans, drawings (if any), and specifications prepared by the City, all of which is made a part of said Contract by certain terms and conditions in said Contract more particularly mentioned, which Contract, consisting of the various Contract Documents specifically mentioned herein and relative hereto, is made a part of this Bond as fully and completely as if said Contract Documents were set forth herein.

NOW THEREFORE, the conditions of this obligation are such that if the above bounden Contractor shall in all respects comply with the terms and conditions of said Contract and his obligation thereunder, including the Contract Documents (which include the plans, drawings, specifications, and conditions prepared by the City, invitation to bid, instructions to bidders, the Contractor’s bid as accepted by the City, the bid and contract and payment bonds, and all addenda, if any, issued prior to the opening of bids), and further that if said Contractor shall promptly make payments to all persons supplying materials, equipment, and/or labor, used directly or indirectly by said Contractor or subcontractors in the prosecution of the work for said contract in accordance with Florida Statutes, Section 255.05 or Section 713.23, then this obligation shall be void; otherwise

to remain in full force and effect for the term of said contract, including and all guarantee periods as specifically mentioned in said Contract Documents.

AND, the said Surety for value received, hereby stipulates and agrees that no change involving any extension of time, or addition to the terms of the Contract or to the work to be performed, or materials to be furnished thereunder, or in the Contract Documents and specifications accompanying the said contract shall affect said obligation of said Surety on this Bond, and the said Surety does hereby waive notice of any such changes, extension of time, alternations, or additions of the terms of the Contract, or to the work, to the Contract Documents, or to the specifications.

Claimant shall give written notice to the Contractor and the Surety as required by Section 255.05 or Section 713.23, Florida Statutes. Any action instituted against the Contractor or Surety under this bond for payment must be in accordance with the notice and time limitation provisions in Section 255.05(2) or Section 713.23, Florida Statutes.

IN WITNESS WHEREOF, the above parties bounded together have executed this instrument this _____ day of _____, 20____, the name and corporate seal of each corporate party being hereto affixed and those presents duly signed by its undersigned representative, pursuant to authority of its governing body.

CONTRACTOR

By: _____ (SEAL)

ATTEST

SURETY

By: _____ (SEAL)

ATTEST

END OF SECTION



City of Key West
P.O. Box 1409
Key West, FL 33041

Notice of Award

Date: _____

Project Number: _____

Owner: City of Key West
Company: City of Key West
Address: Office of the City Clerk
Address: City of Key West P.O. Box 1409
Key West, FL 33041-1409

Project Name: **Repair of the Administration Building Roof at the Richard A. Heyman Environmental Protection Facility**

Dear:

At a meeting of the City of Key West Commission held on _____, 20____, **COMPANY NAME** was awarded the contract for **Repair of the Administration Building Roof at the Richard A. Heyman Environmental Protection Facility**. The total Contract amount shall not exceed \$ _____.

Enclosed please find three copies of the Contract Documents for your execution. Please complete the necessary pages, affixing signatures, notary and / or corporate seals, etc. where necessary and return to this office by **DATE**. Also, you need to be mobilized on **DATE**, and remit a bill to the City of Key West by **DATE**.

The Certificate of Insurance must be attached to the documents; one original and two copies are acceptable.

Powers – of – Attorney must be submitted in each bond document, an original and two copies are permissible.

A copy of your City of Key West Business License Tax Receipt, must be attached, (subcontractors City of Key West Business License Tax Receipt) and one copy in PDF on disc.

Sincerely,

John Paul Castro
Project Manager
cc: Cheri Smith, City Clerk
Project File

CERTIFICATE OF SUBSTANTIAL COMPLETION

Project: Repair of the Administration Building Roof at the Richard A. Heyman
Environmental Protection Facility_____

Project No. _____

DATE OF ISSUANCE _____

CITY _____

CITY'S CONTRACT NO. _____

CONTRACTOR _____ ENGINEER _____

This Certificate of Substantial Completion applies to all Work under the Contract Documents or to the following specified parts thereof:

TO: _____
CITY

And To _____
CONTRACTOR

The Work to which this Certificate applies has been inspected by authorized representatives of City, Contractor, and Engineer and that Work is hereby declared to be substantially complete in accordance with the Contract Documents on

DATE OF SUBSTANTIAL COMPLETION

A tentative list of items to be completed or corrected is attached hereto. This list may not be all-inclusive, and the failure to include an item in it does not alter the responsibility of the Contractor to complete all the Work in accordance with the Contract Documents. The items in the tentative list shall be completed or corrected by Contractor within ____ days of the above date of Substantial Completion.

EJCDC No. 1910-8-D (1990 Edition)
Prepared by the Engineers Joint Contract Documents Committee and endorsed by the Associated General Contractors of America

END OF SECTION

CERTIFICATE OF FINAL COMPLETION

Project: Repair of the Administration Building Roof at the Richard A. Heyman
Environmental Protection Facility

Project No. _____

Date of Issuance: _____

City _____

Contractor _____ Engineer _____

~~~~~  
This Certificate of Completion applies to all Work under the Contract Documents. \_\_\_\_\_  
~~~~~

The Work to which this Certificate applies has been inspected by authorized representatives of City and Engineer, and that Work is hereby declared to be complete in accordance with the Contract Documents on

DATE OF COMPLETION

Executed by ENGINEER on _____, (Date)

ENGINEER

By: _____
(Authorized Signature)

CONTRACTOR accepts this Certificate of Completion on _____, (DATE)

CONTRACTOR

By: _____

CITY accepts this Certificate of Completion on _____, (DATE)

CITY

By: _____
(Authorized Signature)

END OF SECTION

NOTICE TO PROCEED

Date: _____, 20__

Project No: _____

Contractor: _____

Address: _____

Project: Repair of the Administration Building Roof at the Richard A. Heyman Environmental Protection Facility

Project No.

You are hereby notified to commence Work on _____, 20__ for the Repair of the Administration Building Roof at the Richard A. Heyman Environmental Protection Facility and all related Work, as designated by the City in accordance with the Contract made with the City of Key West on the ____ day of _____, 20__. The amount of time to complete the Work is one hundred-twenty (120) consecutive calendar days and should be fully completed on or before _____.

Sincerely,

Project Manager

Receipt of this NOTICE TO PROCEED is hereby acknowledged this, the ____ day of _____, 20__.

CONTRACTOR: _____

By: _____

TITLE: _____

DATE: _____

Please return one (1) copy of this notice to:

CH2M HILL
6410 5th Street
Suite 2A
Key West, FL 33040

PAYMENT APPLICATION AND CERTIFICATE

Application No.: _____ of _____ Date: _____
 Period From: _____ to _____, 20____. Sheet: _____ of _____

Project: Repair of the Administration Building Roof at the Richard A. Heyman
 Environmental Protection Facility
 Project No.: _____

Contractor: _____

Original Contract Sum \$ _____
 Contract Modifications Approved in Previous Applications
 Additions \$ _____ Deductions: \$ _____
 Contract Modifications Approved this Period (List Contract Modifications Nos. ____)
 Additions \$ _____ Deductions: \$ _____

1. Net Change by Contract Modifications (sum of lines 2 and 3) \$ _____
2. Revised Contract Amount (Sum of Lines 1 and 4) \$ _____
3. Total Value of Work to Date (Estimate Attached) \$ _____
4. Percent Project Complete (Line 6 / Line 5 x 100) = _____%
5. Total Materials on Hand (Listing Attached) \$ _____
6. Subtotal-Work Completed and Stored (Sum of Lines 6 and 8) \$ _____
7. Total Retainage (_____% x Line 9) \$ _____
8. Total Earned to Date, Less Retainage (Line 9 less Line 10) \$ _____
9. Less Previous Certificates for Payments
 (item 11 from Previous Application) \$ _____
10. Current Payment Due (Line 11 less Line 12) \$ _____
11. Amount paid to Subcontractors Previous Pay Application \$ _____

The undersigned Contractor certifies that the Work covered by this Application for Payment has been completed in accordance with the Contract Documents that the current payment shown herein is now due, and that title for all Work, materials, and equipment covered in this Application will pass to the City free and clear of all liens at the time of payment.

 Contractor By Date

I hereby acknowledge that the material and labor involved on the above estimate is correct to the best of my knowledge, information and belief, and payment on same is due Contractor.

 Project Manager Date

END OF SECTION

CONSTRUCTION COMPLIANCE CERTIFICATION WITH SPECIFICATIONS AND PLANS

CITY OF KEY WEST

Construction Compliance Certification with Specifications and Plans

Project: Repair of the Administration Building Roof at the Richard A. Heyman Environmental Protection Facility

Project Number:

PO Number:

Date

Monthly

Final

Prime Contractor for the above-referenced Contract hereby verifies, based on personnel knowledge or reasonable investigation and good faith belief, all Quality Control functions and Quality Control sampling and test results are in substantial compliance with the pertinent specification requirements for this Project. This represents work completed between _____ and _____.

Exceptions are listed below (add additional sheets as required).

Item No.:

Exception:

A false statement or omission made in connection with the Certification is sufficient cause for suspension, revocation, or denial of qualification to Bid, and a determination of non-responsibility, and may subject the person and/or entity making the false statement to any civil and criminal penalties available pursuant to applicable State and Federal Law.

Contractor: _____ Date: _____

State of Florida

County of:

Sworn to and subscribed before me this _____ day of _____, 20____

By: _____

(print name of person signing certification)

Notary Public

Commission Expires:

CERTIFICATE OF FINAL PAYMENT

Date: _____

Page: 1 of 2

Payment Application No.: _____

Period From: _____ to _____

Project: Repair of the Administration Building Roof at the Richard A. Heyman
Environmental Protection Facility

Project No.: _____

Contractor: _____

I hereby acknowledge that this Contract has been completed in substantial compliance with the items of the Agreement, Specifications, and Plans, As-Builts, Work Change Directives, and Field Orders. I, therefore, request acceptance of the Work and processing of this final estimate as showing the total amount of money due in compliance with the terms of the Contract.

I, _____, certify to the Owner that the Contractor met the Grant requirements provided in the Contract Documents.

Contractor: _____

Address: _____

With the acceptance of this final payment, we, the Contractor, release the Owner and the Engineer and their agents, from all claims and liability to us, the Contractor, for all things done or furnished in connection with the Work, and every act of the Owner and others relating to, or arising, out of the Work.

Signature

Date

Title

Sworn and subscribed before me this _____ day of _____, 20____

NOTARY PUBLIC, State of Florida at Large

My Commission Expires:

Accepted By:

Project Manager

Date

Owner:

By: _____

Date

STANDARD GENERAL CONDITIONS OF THE CONSTRUCTION CONTRACT

Prepared by

ENGINEERS JOINT CONTRACT DOCUMENTS COMMITTEE

and

Issued and Published Jointly by



AMERICAN COUNCIL OF ENGINEERING COMPANIES

ASSOCIATED GENERAL CONTRACTORS OF AMERICA

AMERICAN SOCIETY OF CIVIL ENGINEERS

PROFESSIONAL ENGINEERS IN PRIVATE PRACTICE
A Practice Division of the
NATIONAL SOCIETY OF PROFESSIONAL ENGINEERS

Endorsed by



CONSTRUCTION SPECIFICATIONS INSTITUTE

These General Conditions have been prepared for use with the Suggested Forms of Agreement Between Owner and Contractor (EJCDC C-520 or C-525, 2007 Editions). Their provisions are interrelated and a change in one may necessitate a change in the other. Comments concerning their usage are contained in the Narrative Guide to the EJCDC Construction Documents (EJCDC C-001, 2007 Edition). For guidance in the preparation of Supplementary Conditions, see Guide to the Preparation of Supplementary Conditions (EJCDC C-800, 2007 Edition).

Copyright © 2007 National Society of Professional Engineers
1420 King Street, Alexandria, VA 22314-2794
(703) 684-2882
www.nspe.org

American Council of Engineering Companies
1015 15th Street N.W., Washington, DC 20005
(202) 347-7474
www.acec.org

American Society of Civil Engineers
1801 Alexander Bell Drive, Reston, VA 20191-4400
(800) 548-2723
www.asce.org

Associated General Contractors of America
2300 Wilson Boulevard, Suite 400, Arlington, VA 22201-3308
(703) 548-3118
www.agc.org

The copyright for this EJCDC document is owned jointly by the four EJCDC sponsoring organizations and held in trust for their benefit by NSPE.

STANDARD GENERAL CONDITIONS OF THE CONSTRUCTION CONTRACT

TABLE OF CONTENTS

Page

ARTICLE 1 – DEFINITIONS AND TERMINOLOGY.....	1
1.01 <i>Defined Terms</i>	1
1.02 <i>Terminology</i>	3
ARTICLE 2 – PRELIMINARY MATTERS	4
2.01 <i>Delivery of Bonds and Evidence of Insurance</i>	4
2.02 <i>Copies of Documents</i>	4
2.03 <i>Commencement of Contract Times; Notice to Proceed</i>	4
2.04 <i>Starting the Work</i>	4
2.05 <i>Before Starting Construction</i>	4
2.06 <i>Preconstruction Conference; Designation of Authorized Representatives</i>	5
2.07 <i>Initial Acceptance of Schedules</i>	5
ARTICLE 3 – CONTRACT DOCUMENTS: INTENT, AMENDING, REUSE	5
3.01 <i>Intent</i>	5
3.02 <i>Reference Standards</i>	5
3.03 <i>Reporting and Resolving Discrepancies</i>	6
3.04 <i>Amending and Supplementing Contract Documents</i>	6
3.05 <i>Reuse of Documents</i>	6
3.06 <i>Electronic Data</i>	7
ARTICLE 4 – AVAILABILITY OF LANDS; SUBSURFACE AND PHYSICAL CONDITIONS; HAZARDOUS ENVIRONMENTAL CONDITIONS; REFERENCE POINTS	7
4.01 <i>Availability of Lands</i>	7
4.02 <i>Subsurface and Physical Conditions</i>	7
4.03 <i>Differing Subsurface or Physical Conditions</i>	7
4.04 <i>Underground Facilities</i>	8
4.05 <i>Reference Points</i>	9
4.06 <i>Hazardous Environmental Condition at Site</i>	9
ARTICLE 5 – BONDS AND INSURANCE.....	10
5.01 <i>Performance, Payment, and Other Bonds</i>	10
5.02 <i>Licensed Sureties and Insurers</i>	11
5.03 <i>Certificates of Insurance</i>	11
5.04 <i>Contractor’s Insurance</i>	11
5.05 <i>Owner’s Liability Insurance</i>	12
5.06 <i>Property Insurance</i>	12
5.07 <i>Waiver of Rights</i>	13
5.08 <i>Receipt and Application of Insurance Proceeds</i>	13
5.09 <i>Acceptance of Bonds and Insurance; Option to Replace</i>	14
5.10 <i>Partial Utilization, Acknowledgment of Property Insurer</i>	14
ARTICLE 6 – CONTRACTOR’S RESPONSIBILITIES.....	14
6.01 <i>Supervision and Superintendence</i>	14
6.02 <i>Labor; Working Hours</i>	14
6.03 <i>Services, Materials, and Equipment</i>	14

6.04	<i>Progress Schedule</i>	15
6.05	<i>Substitutes and “Or-Equals”</i>	15
6.06	<i>Concerning Subcontractors, Suppliers, and Others</i>	17
6.07	<i>Patent Fees and Royalties</i>	17
6.08	<i>Permits</i>	18
6.09	<i>Laws and Regulations</i>	18
6.10	<i>Taxes</i>	18
6.11	<i>Use of Site and Other Areas</i>	18
6.12	<i>Record Documents</i>	19
6.13	<i>Safety and Protection</i>	19
6.14	<i>Safety Representative</i>	20
6.15	<i>Hazard Communication Programs</i>	20
6.16	<i>Emergencies</i>	20
6.17	<i>Shop Drawings and Samples</i>	20
6.18	<i>Continuing the Work</i>	21
6.19	<i>Contractor’s General Warranty and Guarantee</i>	21
6.20	<i>Indemnification</i>	22
6.21	<i>Delegation of Professional Design Services</i>	22
 ARTICLE 7 – OTHER WORK AT THE SITE.....		23
7.01	<i>Related Work at Site</i>	23
7.02	<i>Coordination</i>	23
7.03	<i>Legal Relationships</i>	23
 ARTICLE 8 – OWNER’S RESPONSIBILITIES.....		23
8.01	<i>Communications to Contractor</i>	23
8.02	<i>Replacement of Engineer</i>	23
8.03	<i>Furnish Data</i>	24
8.04	<i>Pay When Due</i>	24
8.05	<i>Lands and Easements; Reports and Tests</i>	24
8.06	<i>Insurance</i>	24
8.07	<i>Change Orders</i>	24
8.08	<i>Inspections, Tests, and Approvals</i>	24
8.09	<i>Limitations on Owner’s Responsibilities</i>	24
8.10	<i>Undisclosed Hazardous Environmental Condition</i>	24
8.11	<i>Evidence of Financial Arrangements</i>	24
8.12	<i>Compliance with Safety Program</i>	24
 ARTICLE 9 – ENGINEER’S STATUS DURING CONSTRUCTION.....		24
9.01	<i>Owner’s Representative</i>	24
9.02	<i>Visits to Site</i>	24
9.03	<i>Project Representative</i>	25
9.04	<i>Authorized Variations in Work</i>	25
9.05	<i>Rejecting Defective Work</i>	25
9.06	<i>Shop Drawings, Change Orders and Payments</i>	25
9.07	<i>Determinations for Unit Price Work</i>	25
9.08	<i>Decisions on Requirements of Contract Documents and Acceptability of Work</i>	25
9.09	<i>Limitations on Engineer’s Authority and Responsibilities</i>	26
9.10	<i>Compliance with Safety Program</i>	26
 ARTICLE 10 – CHANGES IN THE WORK; CLAIMS		26
10.01	<i>Authorized Changes in the Work</i>	26
10.02	<i>Unauthorized Changes in the Work</i>	26
10.03	<i>Execution of Change Orders</i>	26
10.04	<i>Notification to Surety</i>	27
10.05	<i>Claims</i>	27

ARTICLE 11 – COST OF THE WORK; ALLOWANCES; UNIT PRICE WORK	27
11.01 <i>Cost of the Work</i>	27
11.02 <i>Allowances</i>	29
11.03 <i>Unit Price Work</i>	29
ARTICLE 12 – CHANGE OF CONTRACT PRICE; CHANGE OF CONTRACT TIMES	30
12.01 <i>Change of Contract Price</i>	30
12.02 <i>Change of Contract Times</i>	31
12.03 <i>Delays</i>	31
ARTICLE 13 – TESTS AND INSPECTIONS; CORRECTION, REMOVAL OR ACCEPTANCE OF DEFECTIVE WORK. 31	
13.01 <i>Notice of Defects</i>	31
13.02 <i>Access to Work</i>	31
13.03 <i>Tests and Inspections</i>	31
13.04 <i>Uncovering Work</i>	32
13.05 <i>Owner May Stop the Work</i>	32
13.06 <i>Correction or Removal of Defective Work</i>	32
13.07 <i>Correction Period</i>	33
13.08 <i>Acceptance of Defective Work</i>	33
13.09 <i>Owner May Correct Defective Work</i>	33
ARTICLE 14 – PAYMENTS TO CONTRACTOR AND COMPLETION	34
14.01 <i>Schedule of Values</i>	34
14.02 <i>Progress Payments</i>	34
14.03 <i>Contractor’s Warranty of Title</i>	36
14.04 <i>Substantial Completion</i>	36
14.05 <i>Partial Utilization</i>	36
14.06 <i>Final Inspection</i>	37
14.07 <i>Final Payment</i>	37
14.08 <i>Final Completion Delayed</i>	37
14.09 <i>Waiver of Claims</i>	38
ARTICLE 15 – SUSPENSION OF WORK AND TERMINATION	38
15.01 <i>Owner May Suspend Work</i>	38
15.02 <i>Owner May Terminate for Cause</i>	38
15.03 <i>Owner May Terminate For Convenience</i>	39
15.04 <i>Contractor May Stop Work or Terminate</i>	39
ARTICLE 16 – DISPUTE RESOLUTION	39
16.01 <i>Methods and Procedures</i>	39
ARTICLE 17 – MISCELLANEOUS	40
17.01 <i>Giving Notice</i>	40
17.02 <i>Computation of Times</i>	40
17.03 <i>Cumulative Remedies</i>	40
17.04 <i>Survival of Obligations</i>	40
17.05 <i>Controlling Law</i>	40
17.06 <i>Headings</i>	40

STANDARD GENERAL CONDITIONS OF THE CONSTRUCTION CONTRACT

ARTICLE 1 – DEFINITIONS AND TERMINOLOGY

1.01 *Defined Terms*

A. Wherever used in the Bidding Requirements or Contract Documents and printed with initial capital letters, the terms listed below will have the meanings indicated which are applicable to both the singular and plural thereof. In addition to terms specifically defined, terms with initial capital letters in the Contract Documents include references to identified articles and paragraphs, and the titles of other documents or forms.

1. *Addenda*—Written or graphic instruments issued prior to the opening of Bids which clarify, correct, or change the Bidding Requirements or the proposed Contract Documents.

2. *Agreement*—The written instrument which is evidence of the agreement between Owner and Contractor covering the Work.

3. *Application for Payment*—The form acceptable to Engineer which is to be used by Contractor during the course of the Work in requesting progress or final payments and which is to be accompanied by such supporting documentation as is required by the Contract Documents.

4. *Asbestos*—Any material that contains more than one percent asbestos and is friable or is releasing asbestos fibers into the air above current action levels established by the United States Occupational Safety and Health Administration.

5. *Bid*—The offer or proposal of a Bidder submitted on the prescribed form setting forth the prices for the Work to be performed.

6. *Bidder*—The individual or entity who submits a Bid directly to Owner.

7. *Bidding Documents*—The Bidding Requirements and the proposed Contract Documents (including all Addenda).

8. *Bidding Requirements*—The advertisement or invitation to bid, Instructions to Bidders, Bid security of acceptable form, if any, and the Bid Form with any supplements.

9. *Change Order*—A document recommended by Engineer which is signed by Contractor and Owner and authorizes an addition, deletion, or revision in the Work or an adjustment in the Contract Price or the Contract Times, issued on or after the Effective Date of the Agreement.

10. *Claim*—A demand or assertion by Owner or Contractor seeking an adjustment of Contract Price or Contract Times, or both, or other relief with respect to the terms of the Contract. A demand for money or services by a third party is not a Claim.

11. *Contract*—The entire and integrated written agreement between the Owner and Contractor concerning the Work. The Contract supersedes prior negotiations, representations, or agreements, whether written or oral.

12. *Contract Documents*—Those items so designated in the Agreement. Only printed or hard copies of the items listed in the Agreement are Contract Documents. Approved Shop Drawings, other Contractor submittals, and the reports and drawings of subsurface and physical conditions are not Contract Documents.

13. *Contract Price*—The moneys payable by Owner to Contractor for completion of the Work in accordance with the Contract Documents as stated in the Agreement (subject to the provisions of Paragraph 11.03 in the case of Unit Price Work).

14. *Contract Times*—The number of days or the dates stated in the Agreement to: (i) achieve Milestones, if any; (ii) achieve Substantial Completion; and (iii) complete the Work so that it is ready for final payment as evidenced by Engineer's written recommendation of final payment.

15. *Contractor*—The individual or entity with whom Owner has entered into the Agreement.

16. *Cost of the Work*—See Paragraph 11.01 for definition.

17. *Drawings*—That part of the Contract Documents prepared or approved by Engineer which graphically shows the scope, extent, and character of the Work to be performed by Contractor. Shop Drawings and other Contractor submittals are not Drawings as so defined.

18. *Effective Date of the Agreement*—The date indicated in the Agreement on which it becomes effective, but if no such date is indicated, it means the date on which the Agreement is signed and delivered by the last of the two parties to sign and deliver.

19. *Engineer*—The individual or entity named as such in the Agreement.

20. *Field Order*—A written order issued by Engineer which requires minor changes in the Work but which does not involve a change in the Contract Price or the Contract Times.

21. *General Requirements*—Sections of Division 1 of the Specifications.

22. *Hazardous Environmental Condition*—The presence at the Site of Asbestos, PCBs, Petroleum, Hazardous Waste, or Radioactive Material in such quantities or circumstances that may present a substantial danger to persons or property exposed thereto.

23. *Hazardous Waste*—The term Hazardous Waste shall have the meaning provided in Section 1004 of the Solid Waste Disposal Act (42 USC Section 6903) as amended from time to time.

24. *Laws and Regulations; Laws or Regulations*—Any and all applicable laws, rules, regulations, ordinances, codes, and orders of any and all governmental bodies, agencies, authorities, and courts having jurisdiction.

25. *Liens*—Charges, security interests, or encumbrances upon Project funds, real property, or personal property.

26. *Milestone*—A principal event specified in the Contract Documents relating to an intermediate completion date or time prior to Substantial Completion of all the Work.

27. *Notice of Award*—The written notice by Owner to the Successful Bidder stating that upon timely compliance by the Successful Bidder with the conditions precedent listed therein, Owner will sign and deliver the Agreement.

28. *Notice to Proceed*—A written notice given by Owner to Contractor fixing the date on which the Contract Times will commence to run and on which Contractor shall start to perform the Work under the Contract Documents.

29. *Owner*—The individual or entity with whom Contractor has entered into the Agreement and for whom the Work is to be performed.

30. *PCBs*—Polychlorinated biphenyls.

31. *Petroleum*—Petroleum, including crude oil or any fraction thereof which is liquid at standard conditions of temperature and pressure (60 degrees Fahrenheit and 14.7 pounds per square inch absolute), such as oil, petroleum, fuel oil, oil sludge, oil refuse, gasoline, kerosene, and oil mixed with other non-Hazardous Waste and crude oils.

32. *Progress Schedule*—A schedule, prepared and maintained by Contractor, describing the sequence and duration of the activities comprising the Contractor's plan to accomplish the Work within the Contract Times.

33. *Project*—The total construction of which the Work to be performed under the Contract Documents may be the whole, or a part.

34. *Project Manual*—The bound documentary information prepared for bidding and constructing the Work. A listing of the contents of the Project Manual, which may be bound in one or more volumes, is contained in the table(s) of contents.

35. *Radioactive Material*—Source, special nuclear, or byproduct material as defined by the Atomic Energy Act of 1954 (42 USC Section 2011 et seq.) as amended from time to time.

36. *Resident Project Representative*—The authorized representative of Engineer who may be assigned to the Site or any part thereof.

37. *Samples*—Physical examples of materials, equipment, or workmanship that are representative of some portion of the Work and which establish the standards by which such portion of the Work will be judged.

38. *Schedule of Submittals*—A schedule, prepared and maintained by Contractor, of required submittals and the time requirements to support scheduled performance of related construction activities.

39. *Schedule of Values*—A schedule, prepared and maintained by Contractor, allocating portions of the Contract Price to various portions of the Work and used as the basis for reviewing Contractor's Applications for Payment.

40. *Shop Drawings*—All drawings, diagrams, illustrations, schedules, and other data or information which are specifically prepared or assembled by or for Contractor and submitted by Contractor to illustrate some portion of the Work.

41. *Site*—Lands or areas indicated in the Contract Documents as being furnished by Owner upon which the Work is to be performed, including rights-of-way and easements for access thereto, and such other lands furnished by Owner which are designated for the use of Contractor.

42. *Specifications*—That part of the Contract Documents consisting of written requirements for materials, equipment, systems, standards and workmanship as applied to the Work, and certain administrative requirements and procedural matters applicable thereto.

43. *Subcontractor*—An individual or entity having a direct contract with Contractor or with any other Subcontractor for the performance of a part of the Work at the Site.

44. *Substantial Completion*—The time at which the Work (or a specified part thereof) has progressed to the point where, in the opinion of Engineer, the Work (or a specified part thereof) is sufficiently complete, in accordance with the Contract Documents, so that the Work (or a specified part thereof) can be utilized for the purposes for which it is intended. The terms “substantially complete” and “substantially completed” as applied to all or part of the Work refer to Substantial Completion thereof.

45. *Successful Bidder*—The Bidder submitting a responsive Bid to whom Owner makes an award.

46. *Supplementary Conditions*—That part of the Contract Documents which amends or supplements these General Conditions.

47. *Supplier*—A manufacturer, fabricator, supplier, distributor, materialman, or vendor having a direct contract with Contractor or with any Subcontractor to furnish materials or equipment to be incorporated in the Work by Contractor or Subcontractor.

48. *Underground Facilities*—All underground pipelines, conduits, ducts, cables, wires, manholes, vaults, tanks, tunnels, or other such facilities or attachments, and any encasements containing such facilities, including those that convey electricity, gases, steam, liquid petroleum products, telephone or other communications, cable television, water, wastewater, storm water, other liquids or chemicals, or traffic or other control systems.

49. *Unit Price Work*—Work to be paid for on the basis of unit prices.

50. *Work*—The entire construction or the various separately identifiable parts thereof required to be provided

under the Contract Documents. Work includes and is the result of performing or providing all labor, services, and documentation necessary to produce such construction, and furnishing, installing, and incorporating all materials and equipment into such construction, all as required by the Contract Documents.

51. *Work Change Directive*—A written statement to Contractor issued on or after the Effective Date of the Agreement and signed by Owner and recommended by Engineer ordering an addition, deletion, or revision in the Work, or responding to differing or unforeseen subsurface or physical conditions under which the Work is to be performed or to emergencies. A Work Change Directive will not change the Contract Price or the Contract Times but is evidence that the parties expect that the change ordered or documented by a Work Change Directive will be incorporated in a subsequently issued Change Order following negotiations by the parties as to its effect, if any, on the Contract Price or Contract Times.

1.02 Terminology

A. The words and terms discussed in Paragraph 1.02.B through F are not defined but, when used in the Bidding Requirements or Contract Documents, have the indicated meaning.

B. *Intent of Certain Terms or Adjectives:*

1. The Contract Documents include the terms “as allowed,” “as approved,” “as ordered,” “as directed” or terms of like effect or import to authorize an exercise of professional judgment by Engineer. In addition, the adjectives “reasonable,” “suitable,” “acceptable,” “proper,” “satisfactory,” or adjectives of like effect or import are used to describe an action or determination of Engineer as to the Work. It is intended that such exercise of professional judgment, action, or determination will be solely to evaluate, in general, the Work for compliance with the information in the Contract Documents and with the design concept of the Project as a functioning whole as shown or indicated in the Contract Documents (unless there is a specific statement indicating otherwise). The use of any such term or adjective is not intended to and shall not be effective to assign to Engineer any duty or authority to supervise or direct the performance of the Work, or any duty or authority to undertake responsibility contrary to the provisions of Paragraph 9.09 or any other provision of the Contract Documents.

C. *Day:*

1. The word “day” means a calendar day of 24 hours measured from midnight to the next midnight.

D. *Defective:*

1. The word “defective,” when modifying the word “Work,” refers to Work that is unsatisfactory, faulty, or deficient in that it:

- a. does not conform to the Contract Documents; or
- b. does not meet the requirements of any applicable inspection, reference standard, test, or approval referred to in the Contract Documents; or
- c. has been damaged prior to Engineer’s recommendation of final payment (unless responsibility for the protection thereof has been assumed by Owner at Substantial Completion in accordance with Paragraph 14.04 or 14.05).

E. *Furnish, Install, Perform, Provide:*

1. The word “furnish,” when used in connection with services, materials, or equipment, shall mean to supply and deliver said services, materials, or equipment to the Site (or some other specified location) ready for use or installation and in usable or operable condition.

2. The word “install,” when used in connection with services, materials, or equipment, shall mean to put into use or place in final position said services, materials, or equipment complete and ready for intended use.

3. The words “perform” or “provide,” when used in connection with services, materials, or equipment, shall mean to furnish and install said services, materials, or equipment complete and ready for intended use.

4. When “furnish,” “install,” “perform,” or “provide” is not used in connection with services, materials, or equipment in a context clearly requiring an obligation of Contractor, “provide” is implied.

F. Unless stated otherwise in the Contract Documents, words or phrases that have a well-known technical or construction industry or trade meaning are used in the Contract Documents in accordance with such recognized meaning.

ARTICLE 2 – PRELIMINARY MATTERS

2.01 *Delivery of Bonds and Evidence of Insurance*

A. When Contractor delivers the executed counterparts of the Agreement to Owner, Contractor shall also deliver to Owner such bonds as Contractor may be required to furnish.

B. *Evidence of Insurance:* Before any Work at the Site is started, Contractor and Owner shall each deliver to the other, with copies to each additional insured identified in the Supplementary Conditions, certificates of insurance (and other evidence of insurance which either of them or any additional insured may reasonably request) which Contractor and Owner respectively are required to purchase and maintain in accordance with Article 5.

2.02 *Copies of Documents*

A. Owner shall furnish to Contractor up to ten printed or hard copies of the Drawings and Project Manual. Additional copies will be furnished upon request at the cost of reproduction.

2.03 *Commencement of Contract Times; Notice to Proceed*

A. The Contract Times will commence to run on the thirtieth day after the Effective Date of the Agreement or, if a Notice to Proceed is given, on the day indicated in the Notice to Proceed. A Notice to Proceed may be given at any time within 30 days after the Effective Date of the Agreement. In no event will the Contract Times commence to run later than the sixtieth day after the day of Bid opening or the thirtieth day after the Effective Date of the Agreement, whichever date is earlier.

2.04 *Starting the Work*

A. Contractor shall start to perform the Work on the date when the Contract Times commence to run. No Work shall be done at the Site prior to the date on which the Contract Times commence to run.

2.05 *Before Starting Construction*

A. *Preliminary Schedules:* Within 10 days after the Effective Date of the Agreement (unless otherwise specified in the General Requirements), Contractor shall submit to Engineer for timely review:

1. a preliminary Progress Schedule indicating the times (numbers of days or dates) for starting and completing the various stages of the Work, including any Milestones specified in the Contract Documents;

2. a preliminary Schedule of Submittals; and

3. a preliminary Schedule of Values for all of the Work which includes quantities and prices of items which when added together equal the Contract Price and subdivides the Work into component parts in sufficient detail to serve as the basis for progress payments during performance of the Work. Such prices will include an appropriate amount of overhead and profit applicable to each item of Work.

2.06 *Preconstruction Conference; Designation of Authorized Representatives*

A. Before any Work at the Site is started, a conference attended by Owner, Contractor, Engineer, and others as appropriate will be held to establish a working understanding among the parties as to the Work and to discuss the schedules referred to in Paragraph 2.05.A, procedures for handling Shop Drawings and other submittals, processing Applications for Payment, and maintaining required records.

B. At this conference Owner and Contractor each shall designate, in writing, a specific individual to act as its authorized representative with respect to the services and responsibilities under the Contract. Such individuals shall have the authority to transmit instructions, receive information, render decisions relative to the Contract, and otherwise act on behalf of each respective party.

2.07 *Initial Acceptance of Schedules*

A. At least 10 days before submission of the first Application for Payment a conference attended by Contractor, Engineer, and others as appropriate will be held to review for acceptability to Engineer as provided below the schedules submitted in accordance with Paragraph 2.05.A. Contractor shall have an additional 10 days to make corrections and adjustments and to complete and resubmit the schedules. No progress payment shall be made to Contractor until acceptable schedules are submitted to Engineer.

1. The Progress Schedule will be acceptable to Engineer if it provides an orderly progression of the Work to completion within the Contract Times. Such acceptance will not impose on Engineer responsibility for the Progress Schedule, for sequencing, scheduling, or progress of the

Work, nor interfere with or relieve Contractor from Contractor's full responsibility therefor.

2. Contractor's Schedule of Submittals will be acceptable to Engineer if it provides a workable arrangement for reviewing and processing the required submittals.

3. Contractor's Schedule of Values will be acceptable to Engineer as to form and substance if it provides a reasonable allocation of the Contract Price to component parts of the Work.

ARTICLE 3 – CONTRACT DOCUMENTS: INTENT, AMENDING, REUSE

3.01 *Intent*

A. The Contract Documents are complementary; what is required by one is as binding as if required by all.

B. It is the intent of the Contract Documents to describe a functionally complete project (or part thereof) to be constructed in accordance with the Contract Documents. Any labor, documentation, services, materials, or equipment that reasonably may be inferred from the Contract Documents or from prevailing custom or trade usage as being required to produce the indicated result will be provided whether or not specifically called for, at no additional cost to Owner.

C. Clarifications and interpretations of the Contract Documents shall be issued by Engineer as provided in Article 9.

3.02 *Reference Standards*

A. Standards, Specifications, Codes, Laws, and Regulations

1. Reference to standards, specifications, manuals, or codes of any technical society, organization, or association, or to Laws or Regulations, whether such reference be specific or by implication, shall mean the standard, specification, manual, code, or Laws or Regulations in effect at the time of opening of Bids (or on the Effective Date of the Agreement if there were no Bids), except as may be otherwise specifically stated in the Contract Documents.

2. No provision of any such standard, specification, manual, or code, or any instruction of a Supplier, shall be effective to change the duties or responsibilities of Owner, Contractor, or Engineer, or any of their subcontractors, consultants, agents, or employees,

from those set forth in the Contract Documents. No such provision or instruction shall be effective to assign to Owner, Engineer, or any of their officers, directors, members, partners, employees, agents, consultants, or subcontractors, any duty or authority to supervise or direct the performance of the Work or any duty or authority to undertake responsibility inconsistent with the provisions of the Contract Documents.

3.03 *Reporting and Resolving Discrepancies*

A. *Reporting Discrepancies:*

1. *Contractor's Review of Contract Documents Before Starting Work:* Before undertaking each part of the Work, Contractor shall carefully study and compare the Contract Documents and check and verify pertinent figures therein and all applicable field measurements. Contractor shall promptly report in writing to Engineer any conflict, error, ambiguity, or discrepancy which Contractor discovers, or has actual knowledge of, and shall obtain a written interpretation or clarification from Engineer before proceeding with any Work affected thereby.

2. *Contractor's Review of Contract Documents During Performance of Work:* If, during the performance of the Work, Contractor discovers any conflict, error, ambiguity, or discrepancy within the Contract Documents, or between the Contract Documents and (a) any applicable Law or Regulation, (b) any standard, specification, manual, or code, or (c) any instruction of any Supplier, then Contractor shall promptly report it to Engineer in writing. Contractor shall not proceed with the Work affected thereby (except in an emergency as required by Paragraph 6.16.A) until an amendment or supplement to the Contract Documents has been issued by one of the methods indicated in Paragraph 3.04.

3. Contractor shall not be liable to Owner or Engineer for failure to report any conflict, error, ambiguity, or discrepancy in the Contract Documents unless Contractor had actual knowledge thereof.

B. *Resolving Discrepancies:*

1. Except as may be otherwise specifically stated in the Contract Documents, the provisions of the Contract Documents shall take precedence in resolving any conflict, error, ambiguity, or discrepancy between the provisions of the Contract Documents and:

- a. the provisions of any standard, specification, manual, or code, or the instruction of any Supplier (whether or not

specifically incorporated by reference in the Contract Documents); or

- b. the provisions of any Laws or Regulations applicable to the performance of the Work (unless such an interpretation of the provisions of the Contract Documents would result in violation of such Law or Regulation).

3.04 *Amending and Supplementing Contract Documents*

A. The Contract Documents may be amended to provide for additions, deletions, and revisions in the Work or to modify the terms and conditions thereof by either a Change Order or a Work Change Directive.

B. The requirements of the Contract Documents may be supplemented, and minor variations and deviations in the Work may be authorized, by one or more of the following ways:

1. A Field Order;
2. Engineer's approval of a Shop Drawing or Sample (subject to the provisions of Paragraph 6.17.D.3); or
3. Engineer's written interpretation or clarification.

3.05 *Reuse of Documents*

A. Contractor and any Subcontractor or Supplier shall not:

1. have or acquire any title to or ownership rights in any of the Drawings, Specifications, or other documents (or copies of any thereof) prepared by or bearing the seal of Engineer or its consultants, including electronic media editions; or

2. reuse any such Drawings, Specifications, other documents, or copies thereof on extensions of the Project or any other project without written consent of Owner and Engineer and specific written verification or adaptation by Engineer.

B. The prohibitions of this Paragraph 3.05 will survive final payment, or termination of the Contract. Nothing herein shall preclude Contractor from retaining copies of the Contract Documents for record purposes.

3.06 *Electronic Data*

A. Unless otherwise stated in the Supplementary Conditions, the data furnished by Owner or Engineer to Contractor, or by Contractor to Owner or Engineer, that may be relied upon are limited to the printed copies (also known as hard copies). Files in electronic media format of text, data, graphics, or other types are furnished only for the convenience of the receiving party. Any conclusion or information obtained or derived from such electronic files will be at the user's sole risk. If there is a discrepancy between the electronic files and the hard copies, the hard copies govern.

B. Because data stored in electronic media format can deteriorate or be modified inadvertently or otherwise without authorization of the data's creator, the party receiving electronic files agrees that it will perform acceptance tests or procedures within 60 days, after which the receiving party shall be deemed to have accepted the data thus transferred. Any errors detected within the 60-day acceptance period will be corrected by the transferring party.

C. When transferring documents in electronic media format, the transferring party makes no representations as to long term compatibility, usability, or readability of documents resulting from the use of software application packages, operating systems, or computer hardware differing from those used by the data's creator.

ARTICLE 4 – AVAILABILITY OF LANDS; SUBSURFACE AND PHYSICAL CONDITIONS; HAZARDOUS ENVIRONMENTAL CONDITIONS; REFERENCE POINTS

4.01 *Availability of Lands*

A. Owner shall furnish the Site. Owner shall notify Contractor of any encumbrances or restrictions not of general application but specifically related to use of the Site with which Contractor must comply in performing the Work. Owner will obtain in a timely manner and pay for easements for permanent structures or permanent changes in existing facilities. If Contractor and Owner are unable to agree on entitlement to or on the amount or extent, if any, of any adjustment in the Contract Price or Contract Times, or both, as a result of any delay in Owner's furnishing the Site or a part thereof, Contractor may make a Claim therefor as provided in Paragraph 10.05.

B. Upon reasonable written request, Owner shall furnish Contractor with a current statement of record legal title and legal description of the lands upon which the Work is to be performed and Owner's interest therein as

necessary for giving notice of or filing a mechanic's or construction lien against such lands in accordance with applicable Laws and Regulations.

C. Contractor shall provide for all additional lands and access thereto that may be required for temporary construction facilities or storage of materials and equipment.

4.02 *Subsurface and Physical Conditions*

A. *Reports and Drawings:* The Supplementary Conditions identify:

1. those reports known to Owner of explorations and tests of subsurface conditions at or contiguous to the Site; and

2. those drawings known to Owner of physical conditions relating to existing surface or subsurface structures at the Site (except Underground Facilities).

B. *Limited Reliance by Contractor on Technical Data Authorized:* Contractor may rely upon the accuracy of the "technical data" contained in such reports and drawings, but such reports and drawings are not Contract Documents. Such "technical data" is identified in the Supplementary Conditions. Except for such reliance on such "technical data," Contractor may not rely upon or make any claim against Owner or Engineer, or any of their officers, directors, members, partners, employees, agents, consultants, or subcontractors with respect to:

1. the completeness of such reports and drawings for Contractor's purposes, including, but not limited to, any aspects of the means, methods, techniques, sequences, and procedures of construction to be employed by Contractor, and safety precautions and programs incident thereto; or

2. other data, interpretations, opinions, and information contained in such reports or shown or indicated in such drawings; or

3. any Contractor interpretation of or conclusion drawn from any "technical data" or any such other data, interpretations, opinions, or information.

4.03 *Differing Subsurface or Physical Conditions*

A. *Notice:* If Contractor believes that any subsurface or physical condition that is uncovered or revealed either:

1. is of such a nature as to establish that any “technical data” on which Contractor is entitled to rely as provided in Paragraph 4.02 is materially inaccurate; or

2. is of such a nature as to require a change in the Contract Documents; or

3. differs materially from that shown or indicated in the Contract Documents; or

4. is of an unusual nature, and differs materially from conditions ordinarily encountered and generally recognized as inherent in work of the character provided for in the Contract Documents;

5. then Contractor shall, promptly after becoming aware thereof and before further disturbing the subsurface or physical conditions or performing any Work in connection therewith (except in an emergency as required by Paragraph 6.16.A), notify Owner and Engineer in writing about such condition. Contractor shall not further disturb such condition or perform any Work in connection therewith (except as aforesaid) until receipt of written order to do so.

B. *Engineer’s Review:* After receipt of written notice as required by Paragraph 4.03.A, Engineer will promptly review the pertinent condition, determine the necessity of Owner’s obtaining additional exploration or tests with respect thereto, and advise Owner in writing (with a copy to Contractor) of Engineer’s findings and conclusions.

C. *Possible Price and Times Adjustments:*

1. The Contract Price or the Contract Times, or both, will be equitably adjusted to the extent that the existence of such differing subsurface or physical condition causes an increase or decrease in Contractor’s cost of, or time required for, performance of the Work; subject, however, to the following:

a. such condition must meet any one or more of the categories described in Paragraph 4.03.A; and

b. with respect to Work that is paid for on a unit price basis, any adjustment in Contract Price will be subject to the provisions of Paragraphs 9.07 and 11.03.

2. Contractor shall not be entitled to any adjustment in the Contract Price or Contract Times if:

a. Contractor knew of the existence of such conditions at the time Contractor made a final commitment to Owner with respect to Contract Price and Contract Times by the submission of a Bid or becoming bound under a negotiated contract; or

b. the existence of such condition could reasonably have been discovered or revealed as a result of any examination, investigation, exploration, test, or study of the Site and contiguous areas required by the Bidding Requirements or Contract Documents to be conducted by or for Contractor prior to Contractor’s making such final commitment; or

c. Contractor failed to give the written notice as required by Paragraph 4.03.A.

3. If Owner and Contractor are unable to agree on entitlement to or on the amount or extent, if any, of any adjustment in the Contract Price or Contract Times, or both, a Claim may be made therefor as provided in Paragraph 10.05. However, neither Owner or Engineer, or any of their officers, directors, members, partners, employees, agents, consultants, or subcontractors shall be liable to Contractor for any claims, costs, losses, or damages (including but not limited to all fees and charges of engineers, architects, attorneys, and other professionals and all court or arbitration or other dispute resolution costs) sustained by Contractor on or in connection with any other project or anticipated project.

4.04 *Underground Facilities*

A. *Shown or Indicated:* The information and data shown or indicated in the Contract Documents with respect to existing Underground Facilities at or contiguous to the Site is based on information and data furnished to Owner or Engineer by the owners of such Underground Facilities, including Owner, or by others. Unless it is otherwise expressly provided in the Supplementary Conditions:

1. Owner and Engineer shall not be responsible for the accuracy or completeness of any such information or data provided by others; and

2. the cost of all of the following will be included in the Contract Price, and Contractor shall have full responsibility for:

a. reviewing and checking all such information and data;

b. locating all Underground Facilities shown or indicated in the Contract Documents;

c. coordination of the Work with the owners of such Underground Facilities, including Owner, during construction; and

d. the safety and protection of all such Underground Facilities and repairing any damage thereto resulting from the Work.

B. *Not Shown or Indicated:*

1. If an Underground Facility is uncovered or revealed at or contiguous to the Site which was not shown or indicated, or not shown or indicated with reasonable accuracy in the Contract Documents, Contractor shall, promptly after becoming aware thereof and before further disturbing conditions affected thereby or performing any Work in connection therewith (except in an emergency as required by Paragraph 6.16.A), identify the owner of such Underground Facility and give written notice to that owner and to Owner and Engineer. Engineer will promptly review the Underground Facility and determine the extent, if any, to which a change is required in the Contract Documents to reflect and document the consequences of the existence or location of the Underground Facility. During such time, Contractor shall be responsible for the safety and protection of such Underground Facility.

2. If Engineer concludes that a change in the Contract Documents is required, a Work Change Directive or a Change Order will be issued to reflect and document such consequences. An equitable adjustment shall be made in the Contract Price or Contract Times, or both, to the extent that they are attributable to the existence or location of any Underground Facility that was not shown or indicated or not shown or indicated with reasonable accuracy in the Contract Documents and that Contractor did not know of and could not reasonably have been expected to be aware of or to have anticipated. If Owner and Contractor are unable to agree on entitlement to or on the amount or extent, if any, of any such adjustment in Contract Price or Contract Times, Owner or Contractor may make a Claim therefor as provided in Paragraph 10.05.

4.05 *Reference Points*

A. Owner shall provide engineering surveys to establish reference points for construction which in Engineer's judgment are necessary to enable Contractor to proceed with the Work. Contractor shall be responsible for laying out the Work, shall protect and preserve the established reference points and property monuments, and

shall make no changes or relocations without the prior written approval of Owner. Contractor shall report to Engineer whenever any reference point or property monument is lost or destroyed or requires relocation because of necessary changes in grades or locations, and shall be responsible for the accurate replacement or relocation of such reference points or property monuments by professionally qualified personnel.

4.06 *Hazardous Environmental Condition at Site*

A. *Reports and Drawings:* The Supplementary Conditions identify those reports and drawings known to Owner relating to Hazardous Environmental Conditions that have been identified at the Site.

B. *Limited Reliance by Contractor on Technical Data Authorized:* Contractor may rely upon the accuracy of the "technical data" contained in such reports and drawings, but such reports and drawings are not Contract Documents. Such "technical data" is identified in the Supplementary Conditions. Except for such reliance on such "technical data," Contractor may not rely upon or make any claim against Owner or Engineer, or any of their officers, directors, members, partners, employees, agents, consultants, or subcontractors with respect to:

1. the completeness of such reports and drawings for Contractor's purposes, including, but not limited to, any aspects of the means, methods, techniques, sequences and procedures of construction to be employed by Contractor and safety precautions and programs incident thereto; or

2. other data, interpretations, opinions and information contained in such reports or shown or indicated in such drawings; or

3. any Contractor interpretation of or conclusion drawn from any "technical data" or any such other data, interpretations, opinions or information.

C. Contractor shall not be responsible for any Hazardous Environmental Condition uncovered or revealed at the Site which was not shown or indicated in Drawings or Specifications or identified in the Contract Documents to be within the scope of the Work. Contractor shall be responsible for a Hazardous Environmental Condition created with any materials brought to the Site by Contractor, Subcontractors, Suppliers, or anyone else for whom Contractor is responsible.

D. If Contractor encounters a Hazardous Environmental Condition or if Contractor or anyone for whom Contractor is responsible creates a Hazardous

Environmental Condition, Contractor shall immediately: (i) secure or otherwise isolate such condition; (ii) stop all Work in connection with such condition and in any area affected thereby (except in an emergency as required by Paragraph 6.16.A); and (iii) notify Owner and Engineer (and promptly thereafter confirm such notice in writing). Owner shall promptly consult with Engineer concerning the necessity for Owner to retain a qualified expert to evaluate such condition or take corrective action, if any. Promptly after consulting with Engineer, Owner shall take such actions as are necessary to permit Owner to timely obtain required permits and provide Contractor the written notice required by Paragraph 4.06.E.

E. Contractor shall not be required to resume Work in connection with such condition or in any affected area until after Owner has obtained any required permits related thereto and delivered written notice to Contractor: (i) specifying that such condition and any affected area is or has been rendered safe for the resumption of Work; or (ii) specifying any special conditions under which such Work may be resumed safely. If Owner and Contractor cannot agree as to entitlement to or on the amount or extent, if any, of any adjustment in Contract Price or Contract Times, or both, as a result of such Work stoppage or such special conditions under which Work is agreed to be resumed by Contractor, either party may make a Claim therefor as provided in Paragraph 10.05.

F. If after receipt of such written notice Contractor does not agree to resume such Work based on a reasonable belief it is unsafe, or does not agree to resume such Work under such special conditions, then Owner may order the portion of the Work that is in the area affected by such condition to be deleted from the Work. If Owner and Contractor cannot agree as to entitlement to or on the amount or extent, if any, of an adjustment in Contract Price or Contract Times as a result of deleting such portion of the Work, then either party may make a Claim therefor as provided in Paragraph 10.05. Owner may have such deleted portion of the Work performed by Owner's own forces or others in accordance with Article 7.

G. To the fullest extent permitted by Laws and Regulations, Owner shall indemnify and hold harmless Contractor, Subcontractors, and Engineer, and the officers, directors, members, partners, employees, agents, consultants, and subcontractors of each and any of them from and against all claims, costs, losses, and damages (including but not limited to all fees and charges of engineers, architects, attorneys, and other professionals and all court or arbitration or other dispute resolution costs) arising out of or relating to a Hazardous Environmental Condition, provided that such Hazardous Environmental Condition: (i) was not shown or indicated in the Drawings or Specifications or identified in the Contract Documents to

be included within the scope of the Work, and (ii) was not created by Contractor or by anyone for whom Contractor is responsible. Nothing in this Paragraph 4.06.G shall obligate Owner to indemnify any individual or entity from and against the consequences of that individual's or entity's own negligence.

H. To the fullest extent permitted by Laws and Regulations, Contractor shall indemnify and hold harmless Owner and Engineer, and the officers, directors, members, partners, employees, agents, consultants, and subcontractors of each and any of them from and against all claims, costs, losses, and damages (including but not limited to all fees and charges of engineers, architects, attorneys, and other professionals and all court or arbitration or other dispute resolution costs) arising out of or relating to a Hazardous Environmental Condition created by Contractor or by anyone for whom Contractor is responsible. Nothing in this Paragraph 4.06.H shall obligate Contractor to indemnify any individual or entity from and against the consequences of that individual's or entity's own negligence.

I. The provisions of Paragraphs 4.02, 4.03, and 4.04 do not apply to a Hazardous Environmental Condition uncovered or revealed at the Site.

ARTICLE 5 – BONDS AND INSURANCE

5.01 Performance, Payment, and Other Bonds

A. Contractor shall furnish performance and payment bonds, each in an amount at least equal to the Contract Price as security for the faithful performance and payment of all of Contractor's obligations under the Contract Documents. These bonds shall remain in effect until one year after the date when final payment becomes due or until completion of the correction period specified in Paragraph 13.07, whichever is later, except as provided otherwise by Laws or Regulations or by the Contract Documents. Contractor shall also furnish such other bonds as are required by the Contract Documents.

B. All bonds shall be in the form prescribed by the Contract Documents except as provided otherwise by Laws or Regulations, and shall be executed by such sureties as are named in the list of "Companies Holding Certificates of Authority as Acceptable Sureties on Federal Bonds and as Acceptable Reinsuring Companies" as published in Circular 570 (amended) by the Financial Management Service, Surety Bond Branch, U.S. Department of the Treasury. All bonds signed by an agent or attorney-in-fact must be accompanied by a certified copy of that individual's authority to bind the surety. The evidence of

authority shall show that it is effective on the date the agent or attorney-in-fact signed each bond.

C. If the surety on any bond furnished by Contractor is declared bankrupt or becomes insolvent or its right to do business is terminated in any state where any part of the Project is located or it ceases to meet the requirements of Paragraph 5.01.B, Contractor shall promptly notify Owner and Engineer and shall, within 20 days after the event giving rise to such notification, provide another bond and surety, both of which shall comply with the requirements of Paragraphs 5.01.B and 5.02.

5.02 *Licensed Sureties and Insurers*

A. All bonds and insurance required by the Contract Documents to be purchased and maintained by Owner or Contractor shall be obtained from surety or insurance companies that are duly licensed or authorized in the jurisdiction in which the Project is located to issue bonds or insurance policies for the limits and coverages so required. Such surety and insurance companies shall also meet such additional requirements and qualifications as may be provided in the Supplementary Conditions.

5.03 *Certificates of Insurance*

A. Contractor shall deliver to Owner, with copies to each additional insured and loss payee identified in the Supplementary Conditions, certificates of insurance (and other evidence of insurance requested by Owner or any other additional insured) which Contractor is required to purchase and maintain.

B. Owner shall deliver to Contractor, with copies to each additional insured and loss payee identified in the Supplementary Conditions, certificates of insurance (and other evidence of insurance requested by Contractor or any other additional insured) which Owner is required to purchase and maintain.

C. Failure of Owner to demand such certificates or other evidence of Contractor's full compliance with these insurance requirements or failure of Owner to identify a deficiency in compliance from the evidence provided shall not be construed as a waiver of Contractor's obligation to maintain such insurance.

D. Owner does not represent that insurance coverage and limits established in this Contract necessarily will be adequate to protect Contractor.

E. The insurance and insurance limits required herein shall not be deemed as a limitation on Contractor's

liability under the indemnities granted to Owner in the Contract Documents.

5.04 *Contractor's Insurance*

A. Contractor shall purchase and maintain such insurance as is appropriate for the Work being performed and as will provide protection from claims set forth below which may arise out of or result from Contractor's performance of the Work and Contractor's other obligations under the Contract Documents, whether it is to be performed by Contractor, any Subcontractor or Supplier, or by anyone directly or indirectly employed by any of them to perform any of the Work, or by anyone for whose acts any of them may be liable:

1. claims under workers' compensation, disability benefits, and other similar employee benefit acts;

2. claims for damages because of bodily injury, occupational sickness or disease, or death of Contractor's employees;

3. claims for damages because of bodily injury, sickness or disease, or death of any person other than Contractor's employees;

4. claims for damages insured by reasonably available personal injury liability coverage which are sustained:

a. by any person as a result of an offense directly or indirectly related to the employment of such person by Contractor, or

b. by any other person for any other reason;

5. claims for damages, other than to the Work itself, because of injury to or destruction of tangible property wherever located, including loss of use resulting therefrom; and

6. claims for damages because of bodily injury or death of any person or property damage arising out of the ownership, maintenance or use of any motor vehicle.

B. The policies of insurance required by this Paragraph 5.04 shall:

1. with respect to insurance required by Paragraphs 5.04.A.3 through 5.04.A.6 inclusive, be written on an occurrence basis, include as additional insureds (subject to any customary exclusion regarding professional liability) Owner and Engineer, and any other individuals or entities identified in the Supplementary Conditions, all of

whom shall be listed as additional insureds, and include coverage for the respective officers, directors, members, partners, employees, agents, consultants, and subcontractors of each and any of all such additional insureds, and the insurance afforded to these additional insureds shall provide primary coverage for all claims covered thereby;

2. include at least the specific coverages and be written for not less than the limits of liability provided in the Supplementary Conditions or required by Laws or Regulations, whichever is greater;

3. include contractual liability insurance covering Contractor's indemnity obligations under Paragraphs 6.11 and 6.20;

4. contain a provision or endorsement that the coverage afforded will not be canceled, materially changed or renewal refused until at least 30 days prior written notice has been given to Owner and Contractor and to each other additional insured identified in the Supplementary Conditions to whom a certificate of insurance has been issued (and the certificates of insurance furnished by the Contractor pursuant to Paragraph 5.03 will so provide);

5. remain in effect at least until final payment and at all times thereafter when Contractor may be correcting, removing, or replacing defective Work in accordance with Paragraph 13.07; and

6. include completed operations coverage:

a. Such insurance shall remain in effect for two years after final payment.

b. Contractor shall furnish Owner and each other additional insured identified in the Supplementary Conditions, to whom a certificate of insurance has been issued, evidence satisfactory to Owner and any such additional insured of continuation of such insurance at final payment and one year thereafter.

5.05 *Owner's Liability Insurance*

A. In addition to the insurance required to be provided by Contractor under Paragraph 5.04, Owner, at Owner's option, may purchase and maintain at Owner's expense Owner's own liability insurance as will protect Owner against claims which may arise from operations under the Contract Documents.

5.06 *Property Insurance*

A. Unless otherwise provided in the Supplementary Conditions, Owner shall purchase and maintain property insurance upon the Work at the Site in the amount of the full replacement cost thereof (subject to such deductible amounts as may be provided in the Supplementary Conditions or required by Laws and Regulations). This insurance shall:

1. include the interests of Owner, Contractor, Subcontractors, and Engineer, and any other individuals or entities identified in the Supplementary Conditions, and the officers, directors, members, partners, employees, agents, consultants, and subcontractors of each and any of them, each of whom is deemed to have an insurable interest and shall be listed as a loss payee;

2. be written on a Builder's Risk "all-risk" policy form that shall at least include insurance for physical loss or damage to the Work, temporary buildings, falsework, and materials and equipment in transit, and shall insure against at least the following perils or causes of loss: fire, lightning, extended coverage, theft, vandalism and malicious mischief, earthquake, collapse, debris removal, demolition occasioned by enforcement of Laws and Regulations, water damage (other than that caused by flood), and such other perils or causes of loss as may be specifically required by the Supplementary Conditions.

3. include expenses incurred in the repair or replacement of any insured property (including but not limited to fees and charges of engineers and architects);

4. cover materials and equipment stored at the Site or at another location that was agreed to in writing by Owner prior to being incorporated in the Work, provided that such materials and equipment have been included in an Application for Payment recommended by Engineer;

5. allow for partial utilization of the Work by Owner;

6. include testing and startup; and

7. be maintained in effect until final payment is made unless otherwise agreed to in writing by Owner, Contractor, and Engineer with 30 days written notice to each other loss payee to whom a certificate of insurance has been issued.

B. Owner shall purchase and maintain such equipment breakdown insurance or additional property insurance as may be required by the Supplementary Conditions or Laws and Regulations which will include the

interests of Owner, Contractor, Subcontractors, and Engineer, and any other individuals or entities identified in the Supplementary Conditions, and the officers, directors, members, partners, employees, agents, consultants and subcontractors of each and any of them, each of whom is deemed to have an insurable interest and shall be listed as a loss payee.

C. All the policies of insurance (and the certificates or other evidence thereof) required to be purchased and maintained in accordance with this Paragraph 5.06 will contain a provision or endorsement that the coverage afforded will not be canceled or materially changed or renewal refused until at least 30 days prior written notice has been given to Owner and Contractor and to each other loss payee to whom a certificate of insurance has been issued and will contain waiver provisions in accordance with Paragraph 5.07.

D. Owner shall not be responsible for purchasing and maintaining any property insurance specified in this Paragraph 5.06 to protect the interests of Contractor, Subcontractors, or others in the Work to the extent of any deductible amounts that are identified in the Supplementary Conditions. The risk of loss within such identified deductible amount will be borne by Contractor, Subcontractors, or others suffering any such loss, and if any of them wishes property insurance coverage within the limits of such amounts, each may purchase and maintain it at the purchaser's own expense.

E. If Contractor requests in writing that other special insurance be included in the property insurance policies provided under this Paragraph 5.06, Owner shall, if possible, include such insurance, and the cost thereof will be charged to Contractor by appropriate Change Order. Prior to commencement of the Work at the Site, Owner shall in writing advise Contractor whether or not such other insurance has been procured by Owner.

5.07 *Waiver of Rights*

A. Owner and Contractor intend that all policies purchased in accordance with Paragraph 5.06 will protect Owner, Contractor, Subcontractors, and Engineer, and all other individuals or entities identified in the Supplementary Conditions as loss payees (and the officers, directors, members, partners, employees, agents, consultants, and subcontractors of each and any of them) in such policies and will provide primary coverage for all losses and damages caused by the perils or causes of loss covered thereby. All such policies shall contain provisions to the effect that in the event of payment of any loss or damage the insurers will have no rights of recovery against any of the insureds or loss payees thereunder. Owner and

Contractor waive all rights against each other and their respective officers, directors, members, partners, employees, agents, consultants and subcontractors of each and any of them for all losses and damages caused by, arising out of or resulting from any of the perils or causes of loss covered by such policies and any other property insurance applicable to the Work; and, in addition, waive all such rights against Subcontractors and Engineer, and all other individuals or entities identified in the Supplementary Conditions as loss payees (and the officers, directors, members, partners, employees, agents, consultants, and subcontractors of each and any of them) under such policies for losses and damages so caused. None of the above waivers shall extend to the rights that any party making such waiver may have to the proceeds of insurance held by Owner as trustee or otherwise payable under any policy so issued.

B. Owner waives all rights against Contractor, Subcontractors, and Engineer, and the officers, directors, members, partners, employees, agents, consultants and subcontractors of each and any of them for:

1. loss due to business interruption, loss of use, or other consequential loss extending beyond direct physical loss or damage to Owner's property or the Work caused by, arising out of, or resulting from fire or other perils whether or not insured by Owner; and

2. loss or damage to the completed Project or part thereof caused by, arising out of, or resulting from fire or other insured peril or cause of loss covered by any property insurance maintained on the completed Project or part thereof by Owner during partial utilization pursuant to Paragraph 14.05, after Substantial Completion pursuant to Paragraph 14.04, or after final payment pursuant to Paragraph 14.07.

C. Any insurance policy maintained by Owner covering any loss, damage or consequential loss referred to in Paragraph 5.07.B shall contain provisions to the effect that in the event of payment of any such loss, damage, or consequential loss, the insurers will have no rights of recovery against Contractor, Subcontractors, or Engineer, and the officers, directors, members, partners, employees, agents, consultants and subcontractors of each and any of them.

5.08 *Receipt and Application of Insurance Proceeds*

A. Any insured loss under the policies of insurance required by Paragraph 5.06 will be adjusted with Owner and made payable to Owner as fiduciary for the loss payees, as their interests may appear, subject to the requirements of any applicable mortgage clause and of

Paragraph 5.08.B. Owner shall deposit in a separate account any money so received and shall distribute it in accordance with such agreement as the parties in interest may reach. If no other special agreement is reached, the damaged Work shall be repaired or replaced, the moneys so received applied on account thereof, and the Work and the cost thereof covered by an appropriate Change Order.

B. Owner as fiduciary shall have power to adjust and settle any loss with the insurers unless one of the parties in interest shall object in writing within 15 days after the occurrence of loss to Owner's exercise of this power. If such objection be made, Owner as fiduciary shall make settlement with the insurers in accordance with such agreement as the parties in interest may reach. If no such agreement among the parties in interest is reached, Owner as fiduciary shall adjust and settle the loss with the insurers and, if required in writing by any party in interest, Owner as fiduciary shall give bond for the proper performance of such duties.

5.09 *Acceptance of Bonds and Insurance; Option to Replace*

A. If either Owner or Contractor has any objection to the coverage afforded by or other provisions of the bonds or insurance required to be purchased and maintained by the other party in accordance with Article 5 on the basis of non-conformance with the Contract Documents, the objecting party shall so notify the other party in writing within 10 days after receipt of the certificates (or other evidence requested) required by Paragraph 2.01.B. Owner and Contractor shall each provide to the other such additional information in respect of insurance provided as the other may reasonably request. If either party does not purchase or maintain all of the bonds and insurance required of such party by the Contract Documents, such party shall notify the other party in writing of such failure to purchase prior to the start of the Work, or of such failure to maintain prior to any change in the required coverage. Without prejudice to any other right or remedy, the other party may elect to obtain equivalent bonds or insurance to protect such other party's interests at the expense of the party who was required to provide such coverage, and a Change Order shall be issued to adjust the Contract Price accordingly.

5.10 *Partial Utilization, Acknowledgment of Property Insurer*

A. If Owner finds it necessary to occupy or use a portion or portions of the Work prior to Substantial Completion of all the Work as provided in Paragraph 14.05, no such use or occupancy shall commence before the insurers providing the property insurance pursuant to

Paragraph 5.06 have acknowledged notice thereof and in writing effected any changes in coverage necessitated thereby. The insurers providing the property insurance shall consent by endorsement on the policy or policies, but the property insurance shall not be canceled or permitted to lapse on account of any such partial use or occupancy.

ARTICLE 6 – CONTRACTOR'S RESPONSIBILITIES

6.01 *Supervision and Superintendence*

A. Contractor shall supervise, inspect, and direct the Work competently and efficiently, devoting such attention thereto and applying such skills and expertise as may be necessary to perform the Work in accordance with the Contract Documents. Contractor shall be solely responsible for the means, methods, techniques, sequences, and procedures of construction. Contractor shall not be responsible for the negligence of Owner or Engineer in the design or specification of a specific means, method, technique, sequence, or procedure of construction which is shown or indicated in and expressly required by the Contract Documents.

B. At all times during the progress of the Work, Contractor shall assign a competent resident superintendent who shall not be replaced without written notice to Owner and Engineer except under extraordinary circumstances.

6.02 *Labor; Working Hours*

A. Contractor shall provide competent, suitably qualified personnel to survey and lay out the Work and perform construction as required by the Contract Documents. Contractor shall at all times maintain good discipline and order at the Site.

B. Except as otherwise required for the safety or protection of persons or the Work or property at the Site or adjacent thereto, and except as otherwise stated in the Contract Documents, all Work at the Site shall be performed during regular working hours. Contractor will not permit the performance of Work on a Saturday, Sunday, or any legal holiday without Owner's written consent (which will not be unreasonably withheld) given after prior written notice to Engineer.

6.03 *Services, Materials, and Equipment*

A. Unless otherwise specified in the Contract Documents, Contractor shall provide and assume full responsibility for all services, materials, equipment, labor, transportation, construction equipment and machinery, tools, appliances, fuel, power, light, heat, telephone, water,

sanitary facilities, temporary facilities, and all other facilities and incidentals necessary for the performance, testing, start-up, and completion of the Work.

B. All materials and equipment incorporated into the Work shall be as specified or, if not specified, shall be of good quality and new, except as otherwise provided in the Contract Documents. All special warranties and guarantees required by the Specifications shall expressly run to the benefit of Owner. If required by Engineer, Contractor shall furnish satisfactory evidence (including reports of required tests) as to the source, kind, and quality of materials and equipment.

C. All materials and equipment shall be stored, applied, installed, connected, erected, protected, used, cleaned, and conditioned in accordance with instructions of the applicable Supplier, except as otherwise may be provided in the Contract Documents.

6.04 *Progress Schedule*

A. Contractor shall adhere to the Progress Schedule established in accordance with Paragraph 2.07 as it may be adjusted from time to time as provided below.

1. Contractor shall submit to Engineer for acceptance (to the extent indicated in Paragraph 2.07) proposed adjustments in the Progress Schedule that will not result in changing the Contract Times. Such adjustments will comply with any provisions of the General Requirements applicable thereto.

2. Proposed adjustments in the Progress Schedule that will change the Contract Times shall be submitted in accordance with the requirements of Article 12. Adjustments in Contract Times may only be made by a Change Order.

6.05 *Substitutes and "Or-Equals"*

A. Whenever an item of material or equipment is specified or described in the Contract Documents by using the name of a proprietary item or the name of a particular Supplier, the specification or description is intended to establish the type, function, appearance, and quality required. Unless the specification or description contains or is followed by words reading that no like, equivalent, or "or-equal" item or no substitution is permitted, other items of material or equipment or material or equipment of other Suppliers may be submitted to Engineer for review under the circumstances described below.

1. *"Or-Equal" Items:* If in Engineer's sole discretion an item of material or equipment proposed by

Contractor is functionally equal to that named and sufficiently similar so that no change in related Work will be required, it may be considered by Engineer as an "or-equal" item, in which case review and approval of the proposed item may, in Engineer's sole discretion, be accomplished without compliance with some or all of the requirements for approval of proposed substitute items. For the purposes of this Paragraph 6.05.A.1, a proposed item of material or equipment will be considered functionally equal to an item so named if:

a. in the exercise of reasonable judgment Engineer determines that:

1) it is at least equal in materials of construction, quality, durability, appearance, strength, and design characteristics;

2) it will reliably perform at least equally well the function and achieve the results imposed by the design concept of the completed Project as a functioning whole; and

3) it has a proven record of performance and availability of responsive service.

b. Contractor certifies that, if approved and incorporated into the Work:

1) there will be no increase in cost to the Owner or increase in Contract Times; and

2) it will conform substantially to the detailed requirements of the item named in the Contract Documents.

2. *Substitute Items:*

a. If in Engineer's sole discretion an item of material or equipment proposed by Contractor does not qualify as an "or-equal" item under Paragraph 6.05.A.1, it will be considered a proposed substitute item.

b. Contractor shall submit sufficient information as provided below to allow Engineer to determine if the item of material or equipment proposed is essentially equivalent to that named and an acceptable substitute therefor. Requests for review of proposed substitute items of material or equipment will not be accepted by Engineer from anyone other than Contractor.

c. The requirements for review by Engineer will be as set forth in Paragraph 6.05.A.2.d, as supplemented by the General Requirements, and as Engineer may decide is appropriate under the circumstances.

d. Contractor shall make written application to Engineer for review of a proposed substitute item of material or equipment that Contractor seeks to furnish or use. The application:

1) shall certify that the proposed substitute item will:

- a) perform adequately the functions and achieve the results called for by the general design,
- b) be similar in substance to that specified, and
- c) be suited to the same use as that specified;

2) will state:

- a) the extent, if any, to which the use of the proposed substitute item will prejudice Contractor's achievement of Substantial Completion on time,
- b) whether use of the proposed substitute item in the Work will require a change in any of the Contract Documents (or in the provisions of any other direct contract with Owner for other work on the Project) to adapt the design to the proposed substitute item, and
- c) whether incorporation or use of the proposed substitute item in connection with the Work is subject to payment of any license fee or royalty;

3) will identify:

- a) all variations of the proposed substitute item from that specified, and
- b) available engineering, sales, maintenance, repair, and replacement services; and

4) shall contain an itemized estimate of all costs or credits that will result directly or indirectly from use of such substitute item, including costs of redesign and claims of other contractors affected by any resulting change.

B. Substitute Construction Methods or Procedures: If a specific means, method, technique, sequence, or procedure of construction is expressly required by the Contract Documents, Contractor may furnish or utilize a substitute means, method, technique, sequence, or procedure of construction approved by Engineer. Contractor shall submit sufficient information to allow Engineer, in Engineer's sole discretion, to determine that the substitute proposed is equivalent to that expressly called for by the Contract Documents. The requirements for review by Engineer will be similar to those provided in Paragraph 6.05.A.2.

C. Engineer's Evaluation: Engineer will be allowed a reasonable time within which to evaluate each proposal or submittal made pursuant to Paragraphs 6.05.A and 6.05.B. Engineer may require Contractor to furnish additional data about the proposed substitute item. Engineer will be the sole judge of acceptability. No "or equal" or substitute will be ordered, installed or utilized until Engineer's review is complete, which will be evidenced by a Change Order in the case of a substitute and an approved Shop Drawing for an "or equal." Engineer will advise Contractor in writing of any negative determination.

D. Special Guarantee: Owner may require Contractor to furnish at Contractor's expense a special performance guarantee or other surety with respect to any substitute.

E. Engineer's Cost Reimbursement: Engineer will record Engineer's costs in evaluating a substitute proposed or submitted by Contractor pursuant to Paragraphs 6.05.A.2 and 6.05.B. Whether or not Engineer approves a substitute so proposed or submitted by Contractor, Contractor shall reimburse Owner for the reasonable charges of Engineer for evaluating each such proposed substitute. Contractor shall also reimburse Owner for the reasonable charges of Engineer for making changes in the Contract Documents (or in the provisions of any other direct contract with Owner) resulting from the acceptance of each proposed substitute.

F. Contractor's Expense: Contractor shall provide all data in support of any proposed substitute or "or-equal" at Contractor's expense.

6.06 *Concerning Subcontractors, Suppliers, and Others*

A. Contractor shall not employ any Subcontractor, Supplier, or other individual or entity (including those acceptable to Owner as indicated in Paragraph 6.06.B), whether initially or as a replacement, against whom Owner may have reasonable objection. Contractor shall not be required to employ any Subcontractor, Supplier, or other individual or entity to furnish or perform any of the Work against whom Contractor has reasonable objection.

B. If the Supplementary Conditions require the identity of certain Subcontractors, Suppliers, or other individuals or entities to be submitted to Owner in advance for acceptance by Owner by a specified date prior to the Effective Date of the Agreement, and if Contractor has submitted a list thereof in accordance with the Supplementary Conditions, Owner's acceptance (either in writing or by failing to make written objection thereto by the date indicated for acceptance or objection in the Bidding Documents or the Contract Documents) of any such Subcontractor, Supplier, or other individual or entity so identified may be revoked on the basis of reasonable objection after due investigation. Contractor shall submit an acceptable replacement for the rejected Subcontractor, Supplier, or other individual or entity, and the Contract Price will be adjusted by the difference in the cost occasioned by such replacement, and an appropriate Change Order will be issued. No acceptance by Owner of any such Subcontractor, Supplier, or other individual or entity, whether initially or as a replacement, shall constitute a waiver of any right of Owner or Engineer to reject defective Work.

C. Contractor shall be fully responsible to Owner and Engineer for all acts and omissions of the Subcontractors, Suppliers, and other individuals or entities performing or furnishing any of the Work just as Contractor is responsible for Contractor's own acts and omissions. Nothing in the Contract Documents:

1. shall create for the benefit of any such Subcontractor, Supplier, or other individual or entity any contractual relationship between Owner or Engineer and any such Subcontractor, Supplier or other individual or entity; nor

2. shall create any obligation on the part of Owner or Engineer to pay or to see to the payment of any moneys due any such Subcontractor, Supplier, or other individual or entity except as may otherwise be required by Laws and Regulations.

D. Contractor shall be solely responsible for scheduling and coordinating the Work of Subcontractors, Suppliers, and other individuals or entities performing or furnishing any of the Work under a direct or indirect contract with Contractor.

E. Contractor shall require all Subcontractors, Suppliers, and such other individuals or entities performing or furnishing any of the Work to communicate with Engineer through Contractor.

F. The divisions and sections of the Specifications and the identifications of any Drawings shall not control Contractor in dividing the Work among Subcontractors or Suppliers or delineating the Work to be performed by any specific trade.

G. All Work performed for Contractor by a Subcontractor or Supplier will be pursuant to an appropriate agreement between Contractor and the Subcontractor or Supplier which specifically binds the Subcontractor or Supplier to the applicable terms and conditions of the Contract Documents for the benefit of Owner and Engineer. Whenever any such agreement is with a Subcontractor or Supplier who is listed as a loss payee on the property insurance provided in Paragraph 5.06, the agreement between the Contractor and the Subcontractor or Supplier will contain provisions whereby the Subcontractor or Supplier waives all rights against Owner, Contractor, Engineer, and all other individuals or entities identified in the Supplementary Conditions to be listed as insureds or loss payees (and the officers, directors, members, partners, employees, agents, consultants, and subcontractors of each and any of them) for all losses and damages caused by, arising out of, relating to, or resulting from any of the perils or causes of loss covered by such policies and any other property insurance applicable to the Work. If the insurers on any such policies require separate waiver forms to be signed by any Subcontractor or Supplier, Contractor will obtain the same.

6.07 *Patent Fees and Royalties*

A. Contractor shall pay all license fees and royalties and assume all costs incident to the use in the performance of the Work or the incorporation in the Work of any invention, design, process, product, or device which is the subject of patent rights or copyrights held by others. If a particular invention, design, process, product, or device is specified in the Contract Documents for use in the performance of the Work and if, to the actual knowledge of Owner or Engineer, its use is subject to patent rights or copyrights calling for the payment of any license fee or royalty to others, the existence of such rights shall be disclosed by Owner in the Contract Documents.

B. To the fullest extent permitted by Laws and Regulations, Owner shall indemnify and hold harmless Contractor, and its officers, directors, members, partners, employees, agents, consultants, and subcontractors from and against all claims, costs, losses, and damages (including but not limited to all fees and charges of engineers, architects, attorneys, and other professionals, and all court or arbitration or other dispute resolution costs) arising out of or relating to any infringement of patent rights or copyrights incident to the use in the performance of the Work or resulting from the incorporation in the Work of any invention, design, process, product, or device specified in the Contract Documents, but not identified as being subject to payment of any license fee or royalty to others required by patent rights or copyrights.

C. To the fullest extent permitted by Laws and Regulations, Contractor shall indemnify and hold harmless Owner and Engineer, and the officers, directors, members, partners, employees, agents, consultants and subcontractors of each and any of them from and against all claims, costs, losses, and damages (including but not limited to all fees and charges of engineers, architects, attorneys, and other professionals and all court or arbitration or other dispute resolution costs) arising out of or relating to any infringement of patent rights or copyrights incident to the use in the performance of the Work or resulting from the incorporation in the Work of any invention, design, process, product, or device not specified in the Contract Documents.

6.08 *Permits*

A. Unless otherwise provided in the Supplementary Conditions, Contractor shall obtain and pay for all construction permits and licenses. Owner shall assist Contractor, when necessary, in obtaining such permits and licenses. Contractor shall pay all governmental charges and inspection fees necessary for the prosecution of the Work which are applicable at the time of opening of Bids, or, if there are no Bids, on the Effective Date of the Agreement. Owner shall pay all charges of utility owners for connections for providing permanent service to the Work.

6.09 *Laws and Regulations*

A. Contractor shall give all notices required by and shall comply with all Laws and Regulations applicable to the performance of the Work. Except where otherwise expressly required by applicable Laws and Regulations, neither Owner nor Engineer shall be responsible for monitoring Contractor's compliance with any Laws or Regulations.

B. If Contractor performs any Work knowing or having reason to know that it is contrary to Laws or Regulations, Contractor shall bear all claims, costs, losses, and damages (including but not limited to all fees and charges of engineers, architects, attorneys, and other professionals and all court or arbitration or other dispute resolution costs) arising out of or relating to such Work. However, it shall not be Contractor's responsibility to make certain that the Specifications and Drawings are in accordance with Laws and Regulations, but this shall not relieve Contractor of Contractor's obligations under Paragraph 3.03.

C. Changes in Laws or Regulations not known at the time of opening of Bids (or, on the Effective Date of the Agreement if there were no Bids) having an effect on the cost or time of performance of the Work shall be the subject of an adjustment in Contract Price or Contract Times. If Owner and Contractor are unable to agree on entitlement to or on the amount or extent, if any, of any such adjustment, a Claim may be made therefor as provided in Paragraph 10.05.

6.10 *Taxes*

A. Contractor shall pay all sales, consumer, use, and other similar taxes required to be paid by Contractor in accordance with the Laws and Regulations of the place of the Project which are applicable during the performance of the Work.

6.11 *Use of Site and Other Areas*

A. *Limitation on Use of Site and Other Areas:*

1. Contractor shall confine construction equipment, the storage of materials and equipment, and the operations of workers to the Site and other areas permitted by Laws and Regulations, and shall not unreasonably encumber the Site and other areas with construction equipment or other materials or equipment. Contractor shall assume full responsibility for any damage to any such land or area, or to the owner or occupant thereof, or of any adjacent land or areas resulting from the performance of the Work.

2. Should any claim be made by any such owner or occupant because of the performance of the Work, Contractor shall promptly settle with such other party by negotiation or otherwise resolve the claim by arbitration or other dispute resolution proceeding or at law.

3. To the fullest extent permitted by Laws and Regulations, Contractor shall indemnify and hold harmless Owner and Engineer, and the officers, directors, members,

partners, employees, agents, consultants and subcontractors of each and any of them from and against all claims, costs, losses, and damages (including but not limited to all fees and charges of engineers, architects, attorneys, and other professionals and all court or arbitration or other dispute resolution costs) arising out of or relating to any claim or action, legal or equitable, brought by any such owner or occupant against Owner, Engineer, or any other party indemnified hereunder to the extent caused by or based upon Contractor's performance of the Work.

B. Removal of Debris During Performance of the Work: During the progress of the Work Contractor shall keep the Site and other areas free from accumulations of waste materials, rubbish, and other debris. Removal and disposal of such waste materials, rubbish, and other debris shall conform to applicable Laws and Regulations.

C. Cleaning: Prior to Substantial Completion of the Work Contractor shall clean the Site and the Work and make it ready for utilization by Owner. At the completion of the Work Contractor shall remove from the Site all tools, appliances, construction equipment and machinery, and surplus materials and shall restore to original condition all property not designated for alteration by the Contract Documents.

D. Loading Structures: Contractor shall not load nor permit any part of any structure to be loaded in any manner that will endanger the structure, nor shall Contractor subject any part of the Work or adjacent property to stresses or pressures that will endanger it.

6.12 *Record Documents*

A. Contractor shall maintain in a safe place at the Site one record copy of all Drawings, Specifications, Addenda, Change Orders, Work Change Directives, Field Orders, and written interpretations and clarifications in good order and annotated to show changes made during construction. These record documents together with all approved Samples and a counterpart of all approved Shop Drawings will be available to Engineer for reference. Upon completion of the Work, these record documents, Samples, and Shop Drawings will be delivered to Engineer for Owner.

6.13 *Safety and Protection*

A. Contractor shall be solely responsible for initiating, maintaining and supervising all safety precautions and programs in connection with the Work. Such responsibility does not relieve Subcontractors of their responsibility for the safety of persons or property in the performance of their work, nor for compliance with

applicable safety Laws and Regulations. Contractor shall take all necessary precautions for the safety of, and shall provide the necessary protection to prevent damage, injury or loss to:

1. all persons on the Site or who may be affected by the Work;

2. all the Work and materials and equipment to be incorporated therein, whether in storage on or off the Site; and

3. other property at the Site or adjacent thereto, including trees, shrubs, lawns, walks, pavements, roadways, structures, utilities, and Underground Facilities not designated for removal, relocation, or replacement in the course of construction.

B. Contractor shall comply with all applicable Laws and Regulations relating to the safety of persons or property, or to the protection of persons or property from damage, injury, or loss; and shall erect and maintain all necessary safeguards for such safety and protection. Contractor shall notify owners of adjacent property and of Underground Facilities and other utility owners when prosecution of the Work may affect them, and shall cooperate with them in the protection, removal, relocation, and replacement of their property.

C. Contractor shall comply with the applicable requirements of Owner's safety programs, if any. The Supplementary Conditions identify any Owner's safety programs that are applicable to the Work.

D. Contractor shall inform Owner and Engineer of the specific requirements of Contractor's safety program with which Owner's and Engineer's employees and representatives must comply while at the Site.

E. All damage, injury, or loss to any property referred to in Paragraph 6.13.A.2 or 6.13.A.3 caused, directly or indirectly, in whole or in part, by Contractor, any Subcontractor, Supplier, or any other individual or entity directly or indirectly employed by any of them to perform any of the Work, or anyone for whose acts any of them may be liable, shall be remedied by Contractor (except damage or loss attributable to the fault of Drawings or Specifications or to the acts or omissions of Owner or Engineer or anyone employed by any of them, or anyone for whose acts any of them may be liable, and not attributable, directly or indirectly, in whole or in part, to the fault or negligence of Contractor or any Subcontractor, Supplier, or other individual or entity directly or indirectly employed by any of them).

F. Contractor's duties and responsibilities for safety and for protection of the Work shall continue until such time as all the Work is completed and Engineer has issued a notice to Owner and Contractor in accordance with Paragraph 14.07.B that the Work is acceptable (except as otherwise expressly provided in connection with Substantial Completion).

6.14 *Safety Representative*

A. Contractor shall designate a qualified and experienced safety representative at the Site whose duties and responsibilities shall be the prevention of accidents and the maintaining and supervising of safety precautions and programs.

6.15 *Hazard Communication Programs*

A. Contractor shall be responsible for coordinating any exchange of material safety data sheets or other hazard communication information required to be made available to or exchanged between or among employers at the Site in accordance with Laws or Regulations.

6.16 *Emergencies*

A. In emergencies affecting the safety or protection of persons or the Work or property at the Site or adjacent thereto, Contractor is obligated to act to prevent threatened damage, injury, or loss. Contractor shall give Engineer prompt written notice if Contractor believes that any significant changes in the Work or variations from the Contract Documents have been caused thereby or are required as a result thereof. If Engineer determines that a change in the Contract Documents is required because of the action taken by Contractor in response to such an emergency, a Work Change Directive or Change Order will be issued.

6.17 *Shop Drawings and Samples*

A. Contractor shall submit Shop Drawings and Samples to Engineer for review and approval in accordance with the accepted Schedule of Submittals (as required by Paragraph 2.07). Each submittal will be identified as Engineer may require.

1. *Shop Drawings:*

- a. Submit number of copies specified in the General Requirements.
- b. Data shown on the Shop Drawings will be complete with respect to quantities,

dimensions, specified performance and design criteria, materials, and similar data to show Engineer the services, materials, and equipment Contractor proposes to provide and to enable Engineer to review the information for the limited purposes required by Paragraph 6.17.D.

2. *Samples:*

- a. Submit number of Samples specified in the Specifications.
- b. Clearly identify each Sample as to material, Supplier, pertinent data such as catalog numbers, the use for which intended and other data as Engineer may require to enable Engineer to review the submittal for the limited purposes required by Paragraph 6.17.D.

B. Where a Shop Drawing or Sample is required by the Contract Documents or the Schedule of Submittals, any related Work performed prior to Engineer's review and approval of the pertinent submittal will be at the sole expense and responsibility of Contractor.

C. *Submittal Procedures:*

1. Before submitting each Shop Drawing or Sample, Contractor shall have:

- a. reviewed and coordinated each Shop Drawing or Sample with other Shop Drawings and Samples and with the requirements of the Work and the Contract Documents;
- b. determined and verified all field measurements, quantities, dimensions, specified performance and design criteria, installation requirements, materials, catalog numbers, and similar information with respect thereto;
- c. determined and verified the suitability of all materials offered with respect to the indicated application, fabrication, shipping, handling, storage, assembly, and installation pertaining to the performance of the Work; and
- d. determined and verified all information relative to Contractor's responsibilities for means, methods, techniques, sequences, and

procedures of construction, and safety precautions and programs incident thereto.

2. Each submittal shall bear a stamp or specific written certification that Contractor has satisfied Contractor's obligations under the Contract Documents with respect to Contractor's review and approval of that submittal.

3. With each submittal, Contractor shall give Engineer specific written notice of any variations that the Shop Drawing or Sample may have from the requirements of the Contract Documents. This notice shall be both a written communication separate from the Shop Drawings or Sample submittal; and, in addition, by a specific notation made on each Shop Drawing or Sample submitted to Engineer for review and approval of each such variation.

D. Engineer's Review:

1. Engineer will provide timely review of Shop Drawings and Samples in accordance with the Schedule of Submittals acceptable to Engineer. Engineer's review and approval will be only to determine if the items covered by the submittals will, after installation or incorporation in the Work, conform to the information given in the Contract Documents and be compatible with the design concept of the completed Project as a functioning whole as indicated by the Contract Documents.

2. Engineer's review and approval will not extend to means, methods, techniques, sequences, or procedures of construction (except where a particular means, method, technique, sequence, or procedure of construction is specifically and expressly called for by the Contract Documents) or to safety precautions or programs incident thereto. The review and approval of a separate item as such will not indicate approval of the assembly in which the item functions.

3. Engineer's review and approval shall not relieve Contractor from responsibility for any variation from the requirements of the Contract Documents unless Contractor has complied with the requirements of Paragraph 6.17.C.3 and Engineer has given written approval of each such variation by specific written notation thereof incorporated in or accompanying the Shop Drawing or Sample. Engineer's review and approval shall not relieve Contractor from responsibility for complying with the requirements of Paragraph 6.17.C.1.

E. Resubmittal Procedures:

1. Contractor shall make corrections required by Engineer and shall return the required number of corrected

copies of Shop Drawings and submit, as required, new Samples for review and approval. Contractor shall direct specific attention in writing to revisions other than the corrections called for by Engineer on previous submittals.

6.18 *Continuing the Work*

A. Contractor shall carry on the Work and adhere to the Progress Schedule during all disputes or disagreements with Owner. No Work shall be delayed or postponed pending resolution of any disputes or disagreements, except as permitted by Paragraph 15.04 or as Owner and Contractor may otherwise agree in writing.

6.19 *Contractor's General Warranty and Guarantee*

A. Contractor warrants and guarantees to Owner that all Work will be in accordance with the Contract Documents and will not be defective. Engineer and its officers, directors, members, partners, employees, agents, consultants, and subcontractors shall be entitled to rely on representation of Contractor's warranty and guarantee.

B. Contractor's warranty and guarantee hereunder excludes defects or damage caused by:

1. abuse, modification, or improper maintenance or operation by persons other than Contractor, Subcontractors, Suppliers, or any other individual or entity for whom Contractor is responsible; or

2. normal wear and tear under normal usage.

C. Contractor's obligation to perform and complete the Work in accordance with the Contract Documents shall be absolute. None of the following will constitute an acceptance of Work that is not in accordance with the Contract Documents or a release of Contractor's obligation to perform the Work in accordance with the Contract Documents:

1. observations by Engineer;

2. recommendation by Engineer or payment by Owner of any progress or final payment;

3. the issuance of a certificate of Substantial Completion by Engineer or any payment related thereto by Owner;

4. use or occupancy of the Work or any part thereof by Owner;

5. any review and approval of a Shop Drawing or Sample submittal or the issuance of a notice of acceptability by Engineer;

6. any inspection, test, or approval by others; or

7. any correction of defective Work by Owner.

6.20 *Indemnification*

A. To the fullest extent permitted by Laws and Regulations, Contractor shall indemnify and hold harmless Owner and Engineer, and the officers, directors, members, partners, employees, agents, consultants and subcontractors of each and any of them from and against all claims, costs, losses, and damages (including but not limited to all fees and charges of engineers, architects, attorneys, and other professionals and all court or arbitration or other dispute resolution costs) arising out of or relating to the performance of the Work, provided that any such claim, cost, loss, or damage is attributable to bodily injury, sickness, disease, or death, or to injury to or destruction of tangible property (other than the Work itself), including the loss of use resulting therefrom but only to the extent caused by any negligent act or omission of Contractor, any Subcontractor, any Supplier, or any individual or entity directly or indirectly employed by any of them to perform any of the Work or anyone for whose acts any of them may be liable .

B. In any and all claims against Owner or Engineer or any of their officers, directors, members, partners, employees, agents, consultants, or subcontractors by any employee (or the survivor or personal representative of such employee) of Contractor, any Subcontractor, any Supplier, or any individual or entity directly or indirectly employed by any of them to perform any of the Work, or anyone for whose acts any of them may be liable, the indemnification obligation under Paragraph 6.20.A shall not be limited in any way by any limitation on the amount or type of damages, compensation, or benefits payable by or for Contractor or any such Subcontractor, Supplier, or other individual or entity under workers' compensation acts, disability benefit acts, or other employee benefit acts.

C. The indemnification obligations of Contractor under Paragraph 6.20.A shall not extend to the liability of Engineer and Engineer's officers, directors, members, partners, employees, agents, consultants and subcontractors arising out of:

1. the preparation or approval of, or the failure to prepare or approve maps, Drawings, opinions, reports, surveys, Change Orders, designs, or Specifications; or

2. giving directions or instructions, or failing to give them, if that is the primary cause of the injury or damage.

6.21 *Delegation of Professional Design Services*

A. Contractor will not be required to provide professional design services unless such services are specifically required by the Contract Documents for a portion of the Work or unless such services are required to carry out Contractor's responsibilities for construction means, methods, techniques, sequences and procedures. Contractor shall not be required to provide professional services in violation of applicable law.

B. If professional design services or certifications by a design professional related to systems, materials or equipment are specifically required of Contractor by the Contract Documents, Owner and Engineer will specify all performance and design criteria that such services must satisfy. Contractor shall cause such services or certifications to be provided by a properly licensed professional, whose signature and seal shall appear on all drawings, calculations, specifications, certifications, Shop Drawings and other submittals prepared by such professional. Shop Drawings and other submittals related to the Work designed or certified by such professional, if prepared by others, shall bear such professional's written approval when submitted to Engineer.

C. Owner and Engineer shall be entitled to rely upon the adequacy, accuracy and completeness of the services, certifications or approvals performed by such design professionals, provided Owner and Engineer have specified to Contractor all performance and design criteria that such services must satisfy.

D. Pursuant to this Paragraph 6.21, Engineer's review and approval of design calculations and design drawings will be only for the limited purpose of checking for conformance with performance and design criteria given and the design concept expressed in the Contract Documents. Engineer's review and approval of Shop Drawings and other submittals (except design calculations and design drawings) will be only for the purpose stated in Paragraph 6.17.D.1.

E. Contractor shall not be responsible for the adequacy of the performance or design criteria required by the Contract Documents.

ARTICLE 7 – OTHER WORK AT THE SITE

7.01 Related Work at Site

A. Owner may perform other work related to the Project at the Site with Owner's employees, or through other direct contracts therefor, or have other work performed by utility owners. If such other work is not noted in the Contract Documents, then:

1. written notice thereof will be given to Contractor prior to starting any such other work; and

2. if Owner and Contractor are unable to agree on entitlement to or on the amount or extent, if any, of any adjustment in the Contract Price or Contract Times that should be allowed as a result of such other work, a Claim may be made therefor as provided in Paragraph 10.05.

B. Contractor shall afford each other contractor who is a party to such a direct contract, each utility owner, and Owner, if Owner is performing other work with Owner's employees, proper and safe access to the Site, provide a reasonable opportunity for the introduction and storage of materials and equipment and the execution of such other work, and properly coordinate the Work with theirs. Contractor shall do all cutting, fitting, and patching of the Work that may be required to properly connect or otherwise make its several parts come together and properly integrate with such other work. Contractor shall not endanger any work of others by cutting, excavating, or otherwise altering such work; provided, however, that Contractor may cut or alter others' work with the written consent of Engineer and the others whose work will be affected. The duties and responsibilities of Contractor under this Paragraph are for the benefit of such utility owners and other contractors to the extent that there are comparable provisions for the benefit of Contractor in said direct contracts between Owner and such utility owners and other contractors.

C. If the proper execution or results of any part of Contractor's Work depends upon work performed by others under this Article 7, Contractor shall inspect such other work and promptly report to Engineer in writing any delays, defects, or deficiencies in such other work that render it unavailable or unsuitable for the proper execution and results of Contractor's Work. Contractor's failure to so report will constitute an acceptance of such other work as fit and proper for integration with Contractor's Work except for latent defects and deficiencies in such other work.

7.02 Coordination

A. If Owner intends to contract with others for the performance of other work on the Project at the Site, the following will be set forth in Supplementary Conditions:

1. the individual or entity who will have authority and responsibility for coordination of the activities among the various contractors will be identified;

2. the specific matters to be covered by such authority and responsibility will be itemized; and

3. the extent of such authority and responsibilities will be provided.

B. Unless otherwise provided in the Supplementary Conditions, Owner shall have sole authority and responsibility for such coordination.

7.03 Legal Relationships

A. Paragraphs 7.01.A and 7.02 are not applicable for utilities not under the control of Owner.

B. Each other direct contract of Owner under Paragraph 7.01.A shall provide that the other contractor is liable to Owner and Contractor for the reasonable direct delay and disruption costs incurred by Contractor as a result of the other contractor's wrongful actions or inactions.

C. Contractor shall be liable to Owner and any other contractor under direct contract to Owner for the reasonable direct delay and disruption costs incurred by such other contractor as a result of Contractor's wrongful action or inactions.

ARTICLE 8 – OWNER'S RESPONSIBILITIES

8.01 Communications to Contractor

A. Except as otherwise provided in these General Conditions, Owner shall issue all communications to Contractor through Engineer.

8.02 Replacement of Engineer

A. In case of termination of the employment of Engineer, Owner shall appoint an engineer to whom Contractor makes no reasonable objection, whose status under the Contract Documents shall be that of the former Engineer.

8.03 *Furnish Data*

A. Owner shall promptly furnish the data required of Owner under the Contract Documents.

8.04 *Pay When Due*

A. Owner shall make payments to Contractor when they are due as provided in Paragraphs 14.02.C and 14.07.C.

8.05 *Lands and Easements; Reports and Tests*

A. Owner's duties with respect to providing lands and easements and providing engineering surveys to establish reference points are set forth in Paragraphs 4.01 and 4.05. Paragraph 4.02 refers to Owner's identifying and making available to Contractor copies of reports of explorations and tests of subsurface conditions and drawings of physical conditions relating to existing surface or subsurface structures at the Site.

8.06 *Insurance*

A. Owner's responsibilities, if any, with respect to purchasing and maintaining liability and property insurance are set forth in Article 5.

8.07 *Change Orders*

A. Owner is obligated to execute Change Orders as indicated in Paragraph 10.03.

8.08 *Inspections, Tests, and Approvals*

A. Owner's responsibility with respect to certain inspections, tests, and approvals is set forth in Paragraph 13.03.B.

8.09 *Limitations on Owner's Responsibilities*

A. The Owner shall not supervise, direct, or have control or authority over, nor be responsible for, Contractor's means, methods, techniques, sequences, or procedures of construction, or the safety precautions and programs incident thereto, or for any failure of Contractor to comply with Laws and Regulations applicable to the performance of the Work. Owner will not be responsible for Contractor's failure to perform the Work in accordance with the Contract Documents.

8.10 *Undisclosed Hazardous Environmental Condition*

A. Owner's responsibility in respect to an undisclosed Hazardous Environmental Condition is set forth in Paragraph 4.06.

8.11 *Evidence of Financial Arrangements*

A. Upon request of Contractor, Owner shall furnish Contractor reasonable evidence that financial arrangements have been made to satisfy Owner's obligations under the Contract Documents.

8.12 *Compliance with Safety Program*

A. While at the Site, Owner's employees and representatives shall comply with the specific applicable requirements of Contractor's safety programs of which Owner has been informed pursuant to Paragraph 6.13.D.

ARTICLE 9 – ENGINEER'S STATUS DURING CONSTRUCTION

9.01 *Owner's Representative*

A. Engineer will be Owner's representative during the construction period. The duties and responsibilities and the limitations of authority of Engineer as Owner's representative during construction are set forth in the Contract Documents.

9.02 *Visits to Site*

A. Engineer will make visits to the Site at intervals appropriate to the various stages of construction as Engineer deems necessary in order to observe as an experienced and qualified design professional the progress that has been made and the quality of the various aspects of Contractor's executed Work. Based on information obtained during such visits and observations, Engineer, for the benefit of Owner, will determine, in general, if the Work is proceeding in accordance with the Contract Documents. Engineer will not be required to make exhaustive or continuous inspections on the Site to check the quality or quantity of the Work. Engineer's efforts will be directed toward providing for Owner a greater degree of confidence that the completed Work will conform generally to the Contract Documents. On the basis of such visits and observations, Engineer will keep Owner informed of the progress of the Work and will endeavor to guard Owner against defective Work.

B. Engineer's visits and observations are subject to all the limitations on Engineer's authority and responsibility set forth in Paragraph 9.09. Particularly, but

without limitation, during or as a result of Engineer's visits or observations of Contractor's Work, Engineer will not supervise, direct, control, or have authority over or be responsible for Contractor's means, methods, techniques, sequences, or procedures of construction, or the safety precautions and programs incident thereto, or for any failure of Contractor to comply with Laws and Regulations applicable to the performance of the Work.

9.03 *Project Representative*

A. If Owner and Engineer agree, Engineer will furnish a Resident Project Representative to assist Engineer in providing more extensive observation of the Work. The authority and responsibilities of any such Resident Project Representative and assistants will be as provided in the Supplementary Conditions, and limitations on the responsibilities thereof will be as provided in Paragraph 9.09. If Owner designates another representative or agent to represent Owner at the Site who is not Engineer's consultant, agent or employee, the responsibilities and authority and limitations thereon of such other individual or entity will be as provided in the Supplementary Conditions.

9.04 *Authorized Variations in Work*

A. Engineer may authorize minor variations in the Work from the requirements of the Contract Documents which do not involve an adjustment in the Contract Price or the Contract Times and are compatible with the design concept of the completed Project as a functioning whole as indicated by the Contract Documents. These may be accomplished by a Field Order and will be binding on Owner and also on Contractor, who shall perform the Work involved promptly. If Owner or Contractor believes that a Field Order justifies an adjustment in the Contract Price or Contract Times, or both, and the parties are unable to agree on entitlement to or on the amount or extent, if any, of any such adjustment, a Claim may be made therefor as provided in Paragraph 10.05.

9.05 *Rejecting Defective Work*

A. Engineer will have authority to reject Work which Engineer believes to be defective, or that Engineer believes will not produce a completed Project that conforms to the Contract Documents or that will prejudice the integrity of the design concept of the completed Project as a functioning whole as indicated by the Contract Documents. Engineer will also have authority to require special inspection or testing of the Work as provided in Paragraph 13.04, whether or not the Work is fabricated, installed, or completed.

9.06 *Shop Drawings, Change Orders and Payments*

A. In connection with Engineer's authority, and limitations thereof, as to Shop Drawings and Samples, see Paragraph 6.17.

B. In connection with Engineer's authority, and limitations thereof, as to design calculations and design drawings submitted in response to a delegation of professional design services, if any, see Paragraph 6.21.

C. In connection with Engineer's authority as to Change Orders, see Articles 10, 11, and 12.

D. In connection with Engineer's authority as to Applications for Payment, see Article 14.

9.07 *Determinations for Unit Price Work*

A. Engineer will determine the actual quantities and classifications of Unit Price Work performed by Contractor. Engineer will review with Contractor the Engineer's preliminary determinations on such matters before rendering a written decision thereon (by recommendation of an Application for Payment or otherwise). Engineer's written decision thereon will be final and binding (except as modified by Engineer to reflect changed factual conditions or more accurate data) upon Owner and Contractor, subject to the provisions of Paragraph 10.05.

9.08 *Decisions on Requirements of Contract Documents and Acceptability of Work*

A. Engineer will be the initial interpreter of the requirements of the Contract Documents and judge of the acceptability of the Work thereunder. All matters in question and other matters between Owner and Contractor arising prior to the date final payment is due relating to the acceptability of the Work, and the interpretation of the requirements of the Contract Documents pertaining to the performance of the Work, will be referred initially to Engineer in writing within 30 days of the event giving rise to the question.

B. Engineer will, with reasonable promptness, render a written decision on the issue referred. If Owner or Contractor believes that any such decision entitles them to an adjustment in the Contract Price or Contract Times or both, a Claim may be made under Paragraph 10.05. The date of Engineer's decision shall be the date of the event giving rise to the issues referenced for the purposes of Paragraph 10.05.B.

C. Engineer's written decision on the issue referred will be final and binding on Owner and Contractor, subject to the provisions of Paragraph 10.05.

D. When functioning as interpreter and judge under this Paragraph 9.08, Engineer will not show partiality to Owner or Contractor and will not be liable in connection with any interpretation or decision rendered in good faith in such capacity.

9.09 *Limitations on Engineer's Authority and Responsibilities*

A. Neither Engineer's authority or responsibility under this Article 9 or under any other provision of the Contract Documents nor any decision made by Engineer in good faith either to exercise or not exercise such authority or responsibility or the undertaking, exercise, or performance of any authority or responsibility by Engineer shall create, impose, or give rise to any duty in contract, tort, or otherwise owed by Engineer to Contractor, any Subcontractor, any Supplier, any other individual or entity, or to any surety for or employee or agent of any of them.

B. Engineer will not supervise, direct, control, or have authority over or be responsible for Contractor's means, methods, techniques, sequences, or procedures of construction, or the safety precautions and programs incident thereto, or for any failure of Contractor to comply with Laws and Regulations applicable to the performance of the Work. Engineer will not be responsible for Contractor's failure to perform the Work in accordance with the Contract Documents.

C. Engineer will not be responsible for the acts or omissions of Contractor or of any Subcontractor, any Supplier, or of any other individual or entity performing any of the Work.

D. Engineer's review of the final Application for Payment and accompanying documentation and all maintenance and operating instructions, schedules, guarantees, bonds, certificates of inspection, tests and approvals, and other documentation required to be delivered by Paragraph 14.07.A will only be to determine generally that their content complies with the requirements of, and in the case of certificates of inspections, tests, and approvals that the results certified indicate compliance with, the Contract Documents.

E. The limitations upon authority and responsibility set forth in this Paragraph 9.09 shall also apply to the Resident Project Representative, if any, and assistants, if any.

9.10 *Compliance with Safety Program*

A. While at the Site, Engineer's employees and representatives shall comply with the specific applicable requirements of Contractor's safety programs of which Engineer has been informed pursuant to Paragraph 6.13.D.

ARTICLE 10 – CHANGES IN THE WORK; CLAIMS

10.01 *Authorized Changes in the Work*

A. Without invalidating the Contract and without notice to any surety, Owner may, at any time or from time to time, order additions, deletions, or revisions in the Work by a Change Order, or a Work Change Directive. Upon receipt of any such document, Contractor shall promptly proceed with the Work involved which will be performed under the applicable conditions of the Contract Documents (except as otherwise specifically provided).

B. If Owner and Contractor are unable to agree on entitlement to, or on the amount or extent, if any, of an adjustment in the Contract Price or Contract Times, or both, that should be allowed as a result of a Work Change Directive, a Claim may be made therefor as provided in Paragraph 10.05.

10.02 *Unauthorized Changes in the Work*

A. Contractor shall not be entitled to an increase in the Contract Price or an extension of the Contract Times with respect to any work performed that is not required by the Contract Documents as amended, modified, or supplemented as provided in Paragraph 3.04, except in the case of an emergency as provided in Paragraph 6.16 or in the case of uncovering Work as provided in Paragraph 13.04.D.

10.03 *Execution of Change Orders*

A. Owner and Contractor shall execute appropriate Change Orders recommended by Engineer covering:

1. changes in the Work which are: (i) ordered by Owner pursuant to Paragraph 10.01.A, (ii) required because of acceptance of defective Work under Paragraph 13.08.A or Owner's correction of defective Work under Paragraph 13.09, or (iii) agreed to by the parties;

2. changes in the Contract Price or Contract Times which are agreed to by the parties, including any undisputed sum or amount of time for Work actually performed in accordance with a Work Change Directive; and

3. changes in the Contract Price or Contract Times which embody the substance of any written decision rendered by Engineer pursuant to Paragraph 10.05; provided that, in lieu of executing any such Change Order, an appeal may be taken from any such decision in accordance with the provisions of the Contract Documents and applicable Laws and Regulations, but during any such appeal, Contractor shall carry on the Work and adhere to the Progress Schedule as provided in Paragraph 6.18.A.

10.04 *Notification to Surety*

A. If the provisions of any bond require notice to be given to a surety of any change affecting the general scope of the Work or the provisions of the Contract Documents (including, but not limited to, Contract Price or Contract Times), the giving of any such notice will be Contractor's responsibility. The amount of each applicable bond will be adjusted to reflect the effect of any such change.

10.05 *Claims*

A. *Engineer's Decision Required:* All Claims, except those waived pursuant to Paragraph 14.09, shall be referred to the Engineer for decision. A decision by Engineer shall be required as a condition precedent to any exercise by Owner or Contractor of any rights or remedies either may otherwise have under the Contract Documents or by Laws and Regulations in respect of such Claims.

B. *Notice:* Written notice stating the general nature of each Claim shall be delivered by the claimant to Engineer and the other party to the Contract promptly (but in no event later than 30 days) after the start of the event giving rise thereto. The responsibility to substantiate a Claim shall rest with the party making the Claim. Notice of the amount or extent of the Claim, with supporting data shall be delivered to the Engineer and the other party to the Contract within 60 days after the start of such event (unless Engineer allows additional time for claimant to submit additional or more accurate data in support of such Claim). A Claim for an adjustment in Contract Price shall be prepared in accordance with the provisions of Paragraph 12.01.B. A Claim for an adjustment in Contract Times shall be prepared in accordance with the provisions of Paragraph 12.02.B. Each Claim shall be accompanied by claimant's written statement that the adjustment claimed is the entire adjustment to which the claimant believes it is entitled as a result of said event. The opposing party shall submit any response to Engineer and the claimant within 30 days after receipt of the claimant's last submittal (unless Engineer allows additional time).

C. *Engineer's Action:* Engineer will review each Claim and, within 30 days after receipt of the last submittal of the claimant or the last submittal of the opposing party, if any, take one of the following actions in writing:

1. deny the Claim in whole or in part;
2. approve the Claim; or

3. notify the parties that the Engineer is unable to resolve the Claim if, in the Engineer's sole discretion, it would be inappropriate for the Engineer to do so. For purposes of further resolution of the Claim, such notice shall be deemed a denial.

D. In the event that Engineer does not take action on a Claim within said 30 days, the Claim shall be deemed denied.

E. Engineer's written action under Paragraph 10.05.C or denial pursuant to Paragraphs 10.05.C.3 or 10.05.D will be final and binding upon Owner and Contractor, unless Owner or Contractor invoke the dispute resolution procedure set forth in Article 16 within 30 days of such action or denial.

F. No Claim for an adjustment in Contract Price or Contract Times will be valid if not submitted in accordance with this Paragraph 10.05.

ARTICLE 11 – COST OF THE WORK; ALLOWANCES; UNIT PRICE WORK

11.01 *Cost of the Work*

A. *Costs Included:* The term Cost of the Work means the sum of all costs, except those excluded in Paragraph 11.01.B, necessarily incurred and paid by Contractor in the proper performance of the Work. When the value of any Work covered by a Change Order or when a Claim for an adjustment in Contract Price is determined on the basis of Cost of the Work, the costs to be reimbursed to Contractor will be only those additional or incremental costs required because of the change in the Work or because of the event giving rise to the Claim. Except as otherwise may be agreed to in writing by Owner, such costs shall be in amounts no higher than those prevailing in the locality of the Project, shall not include any of the costs itemized in Paragraph 11.01.B, and shall include only the following items:

1. Payroll costs for employees in the direct employ of Contractor in the performance of the Work under schedules of job classifications agreed upon by Owner and Contractor. Such employees shall include,

without limitation, superintendents, foremen, and other personnel employed full time on the Work. Payroll costs for employees not employed full time on the Work shall be apportioned on the basis of their time spent on the Work. Payroll costs shall include, but not be limited to, salaries and wages plus the cost of fringe benefits, which shall include social security contributions, unemployment, excise, and payroll taxes, workers' compensation, health and retirement benefits, bonuses, sick leave, vacation and holiday pay applicable thereto. The expenses of performing Work outside of regular working hours, on Saturday, Sunday, or legal holidays, shall be included in the above to the extent authorized by Owner.

2. Cost of all materials and equipment furnished and incorporated in the Work, including costs of transportation and storage thereof, and Suppliers' field services required in connection therewith. All cash discounts shall accrue to Contractor unless Owner deposits funds with Contractor with which to make payments, in which case the cash discounts shall accrue to Owner. All trade discounts, rebates and refunds and returns from sale of surplus materials and equipment shall accrue to Owner, and Contractor shall make provisions so that they may be obtained.

3. Payments made by Contractor to Subcontractors for Work performed by Subcontractors. If required by Owner, Contractor shall obtain competitive bids from subcontractors acceptable to Owner and Contractor and shall deliver such bids to Owner, who will then determine, with the advice of Engineer, which bids, if any, will be acceptable. If any subcontract provides that the Subcontractor is to be paid on the basis of Cost of the Work plus a fee, the Subcontractor's Cost of the Work and fee shall be determined in the same manner as Contractor's Cost of the Work and fee as provided in this Paragraph 11.01.

4. Costs of special consultants (including but not limited to engineers, architects, testing laboratories, surveyors, attorneys, and accountants) employed for services specifically related to the Work.

5. Supplemental costs including the following:

a. The proportion of necessary transportation, travel, and subsistence expenses of Contractor's employees incurred in discharge of duties connected with the Work.

b. Cost, including transportation and maintenance, of all materials, supplies, equipment, machinery, appliances, office, and

temporary facilities at the Site, and hand tools not owned by the workers, which are consumed in the performance of the Work, and cost, less market value, of such items used but not consumed which remain the property of Contractor.

c. Rentals of all construction equipment and machinery, and the parts thereof whether rented from Contractor or others in accordance with rental agreements approved by Owner with the advice of Engineer, and the costs of transportation, loading, unloading, assembly, dismantling, and removal thereof. All such costs shall be in accordance with the terms of said rental agreements. The rental of any such equipment, machinery, or parts shall cease when the use thereof is no longer necessary for the Work.

d. Sales, consumer, use, and other similar taxes related to the Work, and for which Contractor is liable, as imposed by Laws and Regulations.

e. Deposits lost for causes other than negligence of Contractor, any Subcontractor, or anyone directly or indirectly employed by any of them or for whose acts any of them may be liable, and royalty payments and fees for permits and licenses.

f. Losses and damages (and related expenses) caused by damage to the Work, not compensated by insurance or otherwise, sustained by Contractor in connection with the performance of the Work (except losses and damages within the deductible amounts of property insurance established in accordance with Paragraph 5.06.D), provided such losses and damages have resulted from causes other than the negligence of Contractor, any Subcontractor, or anyone directly or indirectly employed by any of them or for whose acts any of them may be liable. Such losses shall include settlements made with the written consent and approval of Owner. No such losses, damages, and expenses shall be included in the Cost of the Work for the purpose of determining Contractor's fee.

g. The cost of utilities, fuel, and sanitary facilities at the Site.

h. Minor expenses such as telegrams, long distance telephone calls, telephone service at the Site, express and courier services, and similar petty cash items in connection with the Work.

i. The costs of premiums for all bonds and insurance Contractor is required by the Contract Documents to purchase and maintain.

B. *Costs Excluded:* The term Cost of the Work shall not include any of the following items:

1. Payroll costs and other compensation of Contractor's officers, executives, principals (of partnerships and sole proprietorships), general managers, safety managers, engineers, architects, estimators, attorneys, auditors, accountants, purchasing and contracting agents, expeditors, timekeepers, clerks, and other personnel employed by Contractor, whether at the Site or in Contractor's principal or branch office for general administration of the Work and not specifically included in the agreed upon schedule of job classifications referred to in Paragraph 11.01.A.1 or specifically covered by Paragraph 11.01.A.4, all of which are to be considered administrative costs covered by the Contractor's fee.

2. Expenses of Contractor's principal and branch offices other than Contractor's office at the Site.

3. Any part of Contractor's capital expenses, including interest on Contractor's capital employed for the Work and charges against Contractor for delinquent payments.

4. Costs due to the negligence of Contractor, any Subcontractor, or anyone directly or indirectly employed by any of them or for whose acts any of them may be liable, including but not limited to, the correction of defective Work, disposal of materials or equipment wrongly supplied, and making good any damage to property.

5. Other overhead or general expense costs of any kind and the costs of any item not specifically and expressly included in Paragraphs 11.01.A.

C. *Contractor's Fee:* When all the Work is performed on the basis of cost-plus, Contractor's fee shall be determined as set forth in the Agreement. When the value of any Work covered by a Change Order or when a Claim for an adjustment in Contract Price is determined on the basis of Cost of the Work, Contractor's fee shall be determined as set forth in Paragraph 12.01.C.

D. *Documentation:* Whenever the Cost of the Work for any purpose is to be determined pursuant to Paragraphs 11.01.A and 11.01.B, Contractor will establish and maintain records thereof in accordance with generally accepted accounting practices and submit in a form acceptable to Engineer an itemized cost breakdown together with supporting data.

11.02 Allowances

A. It is understood that Contractor has included in the Contract Price all allowances so named in the Contract Documents and shall cause the Work so covered to be performed for such sums and by such persons or entities as may be acceptable to Owner and Engineer.

B. *Cash Allowances:*

1. Contractor agrees that:

a. the cash allowances include the cost to Contractor (less any applicable trade discounts) of materials and equipment required by the allowances to be delivered at the Site, and all applicable taxes; and

b. Contractor's costs for unloading and handling on the Site, labor, installation, overhead, profit, and other expenses contemplated for the cash allowances have been included in the Contract Price and not in the allowances, and no demand for additional payment on account of any of the foregoing will be valid.

C. *Contingency Allowance:*

1. Contractor agrees that a contingency allowance, if any, is for the sole use of Owner to cover unanticipated costs.

D. Prior to final payment, an appropriate Change Order will be issued as recommended by Engineer to reflect actual amounts due Contractor on account of Work covered by allowances, and the Contract Price shall be correspondingly adjusted.

11.03 Unit Price Work

A. Where the Contract Documents provide that all or part of the Work is to be Unit Price Work, initially the Contract Price will be deemed to include for all Unit Price Work an amount equal to the sum of the unit price for each separately identified item of Unit Price Work times the

estimated quantity of each item as indicated in the Agreement.

B. The estimated quantities of items of Unit Price Work are not guaranteed and are solely for the purpose of comparison of Bids and determining an initial Contract Price. Determinations of the actual quantities and classifications of Unit Price Work performed by Contractor will be made by Engineer subject to the provisions of Paragraph 9.07.

C. Each unit price will be deemed to include an amount considered by Contractor to be adequate to cover Contractor's overhead and profit for each separately identified item.

D. Owner or Contractor may make a Claim for an adjustment in the Contract Price in accordance with Paragraph 10.05 if:

1. the quantity of any item of Unit Price Work performed by Contractor differs materially and significantly from the estimated quantity of such item indicated in the Agreement; and

2. there is no corresponding adjustment with respect to any other item of Work; and

3. Contractor believes that Contractor is entitled to an increase in Contract Price as a result of having incurred additional expense or Owner believes that Owner is entitled to a decrease in Contract Price and the parties are unable to agree as to the amount of any such increase or decrease.

ARTICLE 12 – CHANGE OF CONTRACT PRICE; CHANGE OF CONTRACT TIMES

12.01 Change of Contract Price

A. The Contract Price may only be changed by a Change Order. Any Claim for an adjustment in the Contract Price shall be based on written notice submitted by the party making the Claim to the Engineer and the other party to the Contract in accordance with the provisions of Paragraph 10.05.

B. The value of any Work covered by a Change Order or of any Claim for an adjustment in the Contract Price will be determined as follows:

1. where the Work involved is covered by unit prices contained in the Contract Documents, by application of such unit prices to the quantities of the items involved (subject to the provisions of Paragraph 11.03); or

2. where the Work involved is not covered by unit prices contained in the Contract Documents, by a mutually agreed lump sum (which may include an allowance for overhead and profit not necessarily in accordance with Paragraph 12.01.C.2); or

3. where the Work involved is not covered by unit prices contained in the Contract Documents and agreement to a lump sum is not reached under Paragraph 12.01.B.2, on the basis of the Cost of the Work (determined as provided in Paragraph 11.01) plus a Contractor's fee for overhead and profit (determined as provided in Paragraph 12.01.C).

C. *Contractor's Fee:* The Contractor's fee for overhead and profit shall be determined as follows:

1. a mutually acceptable fixed fee; or

2. if a fixed fee is not agreed upon, then a fee based on the following percentages of the various portions of the Cost of the Work:

a. for costs incurred under Paragraphs 11.01.A.1 and 11.01.A.2, the Contractor's fee shall be 15 percent;

b. for costs incurred under Paragraph 11.01.A.3, the Contractor's fee shall be five percent;

c. where one or more tiers of subcontracts are on the basis of Cost of the Work plus a fee and no fixed fee is agreed upon, the intent of Paragraphs 12.01.C.2.a and 12.01.C.2.b is that the Subcontractor who actually performs the Work, at whatever tier, will be paid a fee of 15 percent of the costs incurred by such Subcontractor under Paragraphs 11.01.A.1 and 11.01.A.2 and that any higher tier Subcontractor and Contractor will each be paid a fee of five percent of the amount paid to the next lower tier Subcontractor;

d. no fee shall be payable on the basis of costs itemized under Paragraphs 11.01.A.4, 11.01.A.5, and 11.01.B;

e. the amount of credit to be allowed by Contractor to Owner for any change which results in a net decrease in cost will be the amount of the actual net decrease in cost plus a deduction in Contractor's fee by an amount equal to five percent of such net decrease; and

f. when both additions and credits are involved in any one change, the adjustment in Contractor's fee shall be computed on the basis of the net change in accordance with Paragraphs 12.01.C.2.a through 12.01.C.2.e, inclusive.

12.02 *Change of Contract Times*

A. The Contract Times may only be changed by a Change Order. Any Claim for an adjustment in the Contract Times shall be based on written notice submitted by the party making the Claim to the Engineer and the other party to the Contract in accordance with the provisions of Paragraph 10.05.

B. Any adjustment of the Contract Times covered by a Change Order or any Claim for an adjustment in the Contract Times will be determined in accordance with the provisions of this Article 12.

12.03 *Delays*

A. Where Contractor is prevented from completing any part of the Work within the Contract Times due to delay beyond the control of Contractor, the Contract Times will be extended in an amount equal to the time lost due to such delay if a Claim is made therefor as provided in Paragraph 12.02.A. Delays beyond the control of Contractor shall include, but not be limited to, acts or neglect by Owner, acts or neglect of utility owners or other contractors performing other work as contemplated by Article 7, fires, floods, epidemics, abnormal weather conditions, or acts of God.

B. If Owner, Engineer, or other contractors or utility owners performing other work for Owner as contemplated by Article 7, or anyone for whom Owner is responsible, delays, disrupts, or interferes with the performance or progress of the Work, then Contractor shall be entitled to an equitable adjustment in the Contract Price or the Contract Times, or both. Contractor's entitlement to an adjustment of the Contract Times is conditioned on such adjustment being essential to Contractor's ability to complete the Work within the Contract Times.

C. If Contractor is delayed in the performance or progress of the Work by fire, flood, epidemic, abnormal weather conditions, acts of God, acts or failures to act of utility owners not under the control of Owner, or other causes not the fault of and beyond control of Owner and Contractor, then Contractor shall be entitled to an equitable adjustment in Contract Times, if such adjustment is essential to Contractor's ability to complete the Work within the Contract Times. Such an adjustment shall be

Contractor's sole and exclusive remedy for the delays described in this Paragraph 12.03.C.

D. Owner, Engineer, and their officers, directors, members, partners, employees, agents, consultants, or subcontractors shall not be liable to Contractor for any claims, costs, losses, or damages (including but not limited to all fees and charges of engineers, architects, attorneys, and other professionals and all court or arbitration or other dispute resolution costs) sustained by Contractor on or in connection with any other project or anticipated project.

E. Contractor shall not be entitled to an adjustment in Contract Price or Contract Times for delays within the control of Contractor. Delays attributable to and within the control of a Subcontractor or Supplier shall be deemed to be delays within the control of Contractor.

ARTICLE 13 – TESTS AND INSPECTIONS; CORRECTION, REMOVAL OR ACCEPTANCE OF DEFECTIVE WORK

13.01 *Notice of Defects*

A. Prompt notice of all defective Work of which Owner or Engineer has actual knowledge will be given to Contractor. Defective Work may be rejected, corrected, or accepted as provided in this Article 13.

13.02 *Access to Work*

A. Owner, Engineer, their consultants and other representatives and personnel of Owner, independent testing laboratories, and governmental agencies with jurisdictional interests will have access to the Site and the Work at reasonable times for their observation, inspection, and testing. Contractor shall provide them proper and safe conditions for such access and advise them of Contractor's safety procedures and programs so that they may comply therewith as applicable.

13.03 *Tests and Inspections*

A. Contractor shall give Engineer timely notice of readiness of the Work for all required inspections, tests, or approvals and shall cooperate with inspection and testing personnel to facilitate required inspections or tests.

B. Owner shall employ and pay for the services of an independent testing laboratory to perform all inspections, tests, or approvals required by the Contract Documents except:

1. for inspections, tests, or approvals covered by Paragraphs 13.03.C and 13.03.D below;

2. that costs incurred in connection with tests or inspections conducted pursuant to Paragraph 13.04.B shall be paid as provided in Paragraph 13.04.C; and

3. as otherwise specifically provided in the Contract Documents.

C. If Laws or Regulations of any public body having jurisdiction require any Work (or part thereof) specifically to be inspected, tested, or approved by an employee or other representative of such public body, Contractor shall assume full responsibility for arranging and obtaining such inspections, tests, or approvals, pay all costs in connection therewith, and furnish Engineer the required certificates of inspection or approval.

D. Contractor shall be responsible for arranging and obtaining and shall pay all costs in connection with any inspections, tests, or approvals required for Owner's and Engineer's acceptance of materials or equipment to be incorporated in the Work; or acceptance of materials, mix designs, or equipment submitted for approval prior to Contractor's purchase thereof for incorporation in the Work. Such inspections, tests, or approvals shall be performed by organizations acceptable to Owner and Engineer.

E. If any Work (or the work of others) that is to be inspected, tested, or approved is covered by Contractor without written concurrence of Engineer, Contractor shall, if requested by Engineer, uncover such Work for observation.

F. Uncovering Work as provided in Paragraph 13.03.E shall be at Contractor's expense unless Contractor has given Engineer timely notice of Contractor's intention to cover the same and Engineer has not acted with reasonable promptness in response to such notice.

13.04 *Uncovering Work*

A. If any Work is covered contrary to the written request of Engineer, it must, if requested by Engineer, be uncovered for Engineer's observation and replaced at Contractor's expense.

B. If Engineer considers it necessary or advisable that covered Work be observed by Engineer or inspected or tested by others, Contractor, at Engineer's request, shall uncover, expose, or otherwise make available for observation, inspection, or testing as Engineer may require, that portion of the Work in question, furnishing all necessary labor, material, and equipment.

C. If it is found that the uncovered Work is defective, Contractor shall pay all claims, costs, losses, and damages (including but not limited to all fees and charges of engineers, architects, attorneys, and other professionals and all court or arbitration or other dispute resolution costs) arising out of or relating to such uncovering, exposure, observation, inspection, and testing, and of satisfactory replacement or reconstruction (including but not limited to all costs of repair or replacement of work of others); and Owner shall be entitled to an appropriate decrease in the Contract Price. If the parties are unable to agree as to the amount thereof, Owner may make a Claim therefor as provided in Paragraph 10.05.

D. If the uncovered Work is not found to be defective, Contractor shall be allowed an increase in the Contract Price or an extension of the Contract Times, or both, directly attributable to such uncovering, exposure, observation, inspection, testing, replacement, and reconstruction. If the parties are unable to agree as to the amount or extent thereof, Contractor may make a Claim therefor as provided in Paragraph 10.05.

13.05 *Owner May Stop the Work*

A. If the Work is defective, or Contractor fails to supply sufficient skilled workers or suitable materials or equipment, or fails to perform the Work in such a way that the completed Work will conform to the Contract Documents, Owner may order Contractor to stop the Work, or any portion thereof, until the cause for such order has been eliminated; however, this right of Owner to stop the Work shall not give rise to any duty on the part of Owner to exercise this right for the benefit of Contractor, any Subcontractor, any Supplier, any other individual or entity, or any surety for, or employee or agent of any of them.

13.06 *Correction or Removal of Defective Work*

A. Promptly after receipt of written notice, Contractor shall correct all defective Work, whether or not fabricated, installed, or completed, or, if the Work has been rejected by Engineer, remove it from the Project and replace it with Work that is not defective. Contractor shall pay all claims, costs, losses, and damages (including but not limited to all fees and charges of engineers, architects, attorneys, and other professionals and all court or arbitration or other dispute resolution costs) arising out of or relating to such correction or removal (including but not limited to all costs of repair or replacement of work of others).

B. When correcting defective Work under the terms of this Paragraph 13.06 or Paragraph 13.07, Contractor shall take no action that would void or otherwise

impair Owner's special warranty and guarantee, if any, on said Work.

13.07 *Correction Period*

A. If within one year after the date of Substantial Completion (or such longer period of time as may be prescribed by the terms of any applicable special guarantee required by the Contract Documents) or by any specific provision of the Contract Documents, any Work is found to be defective, or if the repair of any damages to the land or areas made available for Contractor's use by Owner or permitted by Laws and Regulations as contemplated in Paragraph 6.11.A is found to be defective, Contractor shall promptly, without cost to Owner and in accordance with Owner's written instructions:

1. repair such defective land or areas; or
2. correct such defective Work; or
3. if the defective Work has been rejected by Owner, remove it from the Project and replace it with Work that is not defective, and
4. satisfactorily correct or repair or remove and replace any damage to other Work, to the work of others or other land or areas resulting therefrom.

B. If Contractor does not promptly comply with the terms of Owner's written instructions, or in an emergency where delay would cause serious risk of loss or damage, Owner may have the defective Work corrected or repaired or may have the rejected Work removed and replaced. All claims, costs, losses, and damages (including but not limited to all fees and charges of engineers, architects, attorneys, and other professionals and all court or arbitration or other dispute resolution costs) arising out of or relating to such correction or repair or such removal and replacement (including but not limited to all costs of repair or replacement of work of others) will be paid by Contractor.

C. In special circumstances where a particular item of equipment is placed in continuous service before Substantial Completion of all the Work, the correction period for that item may start to run from an earlier date if so provided in the Specifications.

D. Where defective Work (and damage to other Work resulting therefrom) has been corrected or removed and replaced under this Paragraph 13.07, the correction period hereunder with respect to such Work will be extended for an additional period of one year after such

correction or removal and replacement has been satisfactorily completed.

E. Contractor's obligations under this Paragraph 13.07 are in addition to any other obligation or warranty. The provisions of this Paragraph 13.07 shall not be construed as a substitute for, or a waiver of, the provisions of any applicable statute of limitation or repose.

13.08 *Acceptance of Defective Work*

A. If, instead of requiring correction or removal and replacement of defective Work, Owner (and, prior to Engineer's recommendation of final payment, Engineer) prefers to accept it, Owner may do so. Contractor shall pay all claims, costs, losses, and damages (including but not limited to all fees and charges of engineers, architects, attorneys, and other professionals and all court or arbitration or other dispute resolution costs) attributable to Owner's evaluation of and determination to accept such defective Work (such costs to be approved by Engineer as to reasonableness) and for the diminished value of the Work to the extent not otherwise paid by Contractor pursuant to this sentence. If any such acceptance occurs prior to Engineer's recommendation of final payment, a Change Order will be issued incorporating the necessary revisions in the Contract Documents with respect to the Work, and Owner shall be entitled to an appropriate decrease in the Contract Price, reflecting the diminished value of Work so accepted. If the parties are unable to agree as to the amount thereof, Owner may make a Claim therefor as provided in Paragraph 10.05. If the acceptance occurs after such recommendation, an appropriate amount will be paid by Contractor to Owner.

13.09 *Owner May Correct Defective Work*

A. If Contractor fails within a reasonable time after written notice from Engineer to correct defective Work, or to remove and replace rejected Work as required by Engineer in accordance with Paragraph 13.06.A, or if Contractor fails to perform the Work in accordance with the Contract Documents, or if Contractor fails to comply with any other provision of the Contract Documents, Owner may, after seven days written notice to Contractor, correct, or remedy any such deficiency.

B. In exercising the rights and remedies under this Paragraph 13.09, Owner shall proceed expeditiously. In connection with such corrective or remedial action, Owner may exclude Contractor from all or part of the Site, take possession of all or part of the Work and suspend Contractor's services related thereto, take possession of Contractor's tools, appliances, construction equipment and machinery at the Site, and incorporate in the Work all

materials and equipment stored at the Site or for which Owner has paid Contractor but which are stored elsewhere. Contractor shall allow Owner, Owner's representatives, agents and employees, Owner's other contractors, and Engineer and Engineer's consultants access to the Site to enable Owner to exercise the rights and remedies under this Paragraph.

C. All claims, costs, losses, and damages (including but not limited to all fees and charges of engineers, architects, attorneys, and other professionals and all court or arbitration or other dispute resolution costs) incurred or sustained by Owner in exercising the rights and remedies under this Paragraph 13.09 will be charged against Contractor, and a Change Order will be issued incorporating the necessary revisions in the Contract Documents with respect to the Work; and Owner shall be entitled to an appropriate decrease in the Contract Price. If the parties are unable to agree as to the amount of the adjustment, Owner may make a Claim therefor as provided in Paragraph 10.05. Such claims, costs, losses and damages will include but not be limited to all costs of repair, or replacement of work of others destroyed or damaged by correction, removal, or replacement of Contractor's defective Work.

D. Contractor shall not be allowed an extension of the Contract Times because of any delay in the performance of the Work attributable to the exercise by Owner of Owner's rights and remedies under this Paragraph 13.09.

ARTICLE 14 – PAYMENTS TO CONTRACTOR AND COMPLETION

14.01 *Schedule of Values*

A. The Schedule of Values established as provided in Paragraph 2.07.A will serve as the basis for progress payments and will be incorporated into a form of Application for Payment acceptable to Engineer. Progress payments on account of Unit Price Work will be based on the number of units completed.

14.02 *Progress Payments*

A. *Applications for Payments:*

1. At least 20 days before the date established in the Agreement for each progress payment (but not more often than once a month), Contractor shall submit to Engineer for review an Application for Payment filled out and signed by Contractor covering the Work completed as of the date of the Application and accompanied by such supporting documentation as is required by the Contract

Documents. If payment is requested on the basis of materials and equipment not incorporated in the Work but delivered and suitably stored at the Site or at another location agreed to in writing, the Application for Payment shall also be accompanied by a bill of sale, invoice, or other documentation warranting that Owner has received the materials and equipment free and clear of all Liens and evidence that the materials and equipment are covered by appropriate property insurance or other arrangements to protect Owner's interest therein, all of which must be satisfactory to Owner.

2. Beginning with the second Application for Payment, each Application shall include an affidavit of Contractor stating that all previous progress payments received on account of the Work have been applied on account to discharge Contractor's legitimate obligations associated with prior Applications for Payment.

3. The amount of retainage with respect to progress payments will be as stipulated in the Agreement.

B. *Review of Applications:*

1. Engineer will, within 10 days after receipt of each Application for Payment, either indicate in writing a recommendation of payment and present the Application to Owner or return the Application to Contractor indicating in writing Engineer's reasons for refusing to recommend payment. In the latter case, Contractor may make the necessary corrections and resubmit the Application.

2. Engineer's recommendation of any payment requested in an Application for Payment will constitute a representation by Engineer to Owner, based on Engineer's observations of the executed Work as an experienced and qualified design professional, and on Engineer's review of the Application for Payment and the accompanying data and schedules, that to the best of Engineer's knowledge, information and belief:

a. the Work has progressed to the point indicated;

b. the quality of the Work is generally in accordance with the Contract Documents (subject to an evaluation of the Work as a functioning whole prior to or upon Substantial Completion, the results of any subsequent tests called for in the Contract Documents, a final determination of quantities and classifications for Unit Price Work under Paragraph 9.07, and any other qualifications stated in the recommendation); and

c. the conditions precedent to Contractor's being entitled to such payment appear to have been fulfilled in so far as it is Engineer's responsibility to observe the Work.

3. By recommending any such payment Engineer will not thereby be deemed to have represented that:

a. inspections made to check the quality or the quantity of the Work as it has been performed have been exhaustive, extended to every aspect of the Work in progress, or involved detailed inspections of the Work beyond the responsibilities specifically assigned to Engineer in the Contract Documents; or

b. there may not be other matters or issues between the parties that might entitle Contractor to be paid additionally by Owner or entitle Owner to withhold payment to Contractor.

4. Neither Engineer's review of Contractor's Work for the purposes of recommending payments nor Engineer's recommendation of any payment, including final payment, will impose responsibility on Engineer:

a. to supervise, direct, or control the Work, or

b. for the means, methods, techniques, sequences, or procedures of construction, or the safety precautions and programs incident thereto, or

c. for Contractor's failure to comply with Laws and Regulations applicable to Contractor's performance of the Work, or

d. to make any examination to ascertain how or for what purposes Contractor has used the moneys paid on account of the Contract Price, or

e. to determine that title to any of the Work, materials, or equipment has passed to Owner free and clear of any Liens.

5. Engineer may refuse to recommend the whole or any part of any payment if, in Engineer's opinion, it would be incorrect to make the representations to Owner stated in Paragraph 14.02.B.2. Engineer may also refuse to recommend any such payment or, because of subsequently

discovered evidence or the results of subsequent inspections or tests, revise or revoke any such payment recommendation previously made, to such extent as may be necessary in Engineer's opinion to protect Owner from loss because:

a. the Work is defective, or completed Work has been damaged, requiring correction or replacement;

b. the Contract Price has been reduced by Change Orders;

c. Owner has been required to correct defective Work or complete Work in accordance with Paragraph 13.09; or

d. Engineer has actual knowledge of the occurrence of any of the events enumerated in Paragraph 15.02.A.

C. Payment Becomes Due:

1. Ten days after presentation of the Application for Payment to Owner with Engineer's recommendation, the amount recommended will (subject to the provisions of Paragraph 14.02.D) become due, and when due will be paid by Owner to Contractor.

D. Reduction in Payment:

1. Owner may refuse to make payment of the full amount recommended by Engineer because:

a. claims have been made against Owner on account of Contractor's performance or furnishing of the Work;

b. Liens have been filed in connection with the Work, except where Contractor has delivered a specific bond satisfactory to Owner to secure the satisfaction and discharge of such Liens;

c. there are other items entitling Owner to a set-off against the amount recommended; or

d. Owner has actual knowledge of the occurrence of any of the events enumerated in Paragraphs 14.02.B.5.a through 14.02.B.5.c or Paragraph 15.02.A.

2. If Owner refuses to make payment of the full amount recommended by Engineer, Owner will give Contractor immediate written notice (with a copy to

Engineer) stating the reasons for such action and promptly pay Contractor any amount remaining after deduction of the amount so withheld. Owner shall promptly pay Contractor the amount so withheld, or any adjustment thereto agreed to by Owner and Contractor, when Contractor remedies the reasons for such action.

3. Upon a subsequent determination that Owner's refusal of payment was not justified, the amount wrongfully withheld shall be treated as an amount due as determined by Paragraph 14.02.C.1 and subject to interest as provided in the Agreement.

14.03 *Contractor's Warranty of Title*

A. Contractor warrants and guarantees that title to all Work, materials, and equipment covered by any Application for Payment, whether incorporated in the Project or not, will pass to Owner no later than the time of payment free and clear of all Liens.

14.04 *Substantial Completion*

A. When Contractor considers the entire Work ready for its intended use Contractor shall notify Owner and Engineer in writing that the entire Work is substantially complete (except for items specifically listed by Contractor as incomplete) and request that Engineer issue a certificate of Substantial Completion.

B. Promptly after Contractor's notification, Owner, Contractor, and Engineer shall make an inspection of the Work to determine the status of completion. If Engineer does not consider the Work substantially complete, Engineer will notify Contractor in writing giving the reasons therefor.

C. If Engineer considers the Work substantially complete, Engineer will deliver to Owner a tentative certificate of Substantial Completion which shall fix the date of Substantial Completion. There shall be attached to the certificate a tentative list of items to be completed or corrected before final payment. Owner shall have seven days after receipt of the tentative certificate during which to make written objection to Engineer as to any provisions of the certificate or attached list. If, after considering such objections, Engineer concludes that the Work is not substantially complete, Engineer will, within 14 days after submission of the tentative certificate to Owner, notify Contractor in writing, stating the reasons therefor. If, after consideration of Owner's objections, Engineer considers the Work substantially complete, Engineer will, within said 14 days, execute and deliver to Owner and Contractor a definitive certificate of Substantial Completion (with a revised tentative list of items to be completed or corrected)

reflecting such changes from the tentative certificate as Engineer believes justified after consideration of any objections from Owner.

D. At the time of delivery of the tentative certificate of Substantial Completion, Engineer will deliver to Owner and Contractor a written recommendation as to division of responsibilities pending final payment between Owner and Contractor with respect to security, operation, safety, and protection of the Work, maintenance, heat, utilities, insurance, and warranties and guarantees. Unless Owner and Contractor agree otherwise in writing and so inform Engineer in writing prior to Engineer's issuing the definitive certificate of Substantial Completion, Engineer's aforesaid recommendation will be binding on Owner and Contractor until final payment.

E. Owner shall have the right to exclude Contractor from the Site after the date of Substantial Completion subject to allowing Contractor reasonable access to remove its property and complete or correct items on the tentative list.

14.05 *Partial Utilization*

A. Prior to Substantial Completion of all the Work, Owner may use or occupy any substantially completed part of the Work which has specifically been identified in the Contract Documents, or which Owner, Engineer, and Contractor agree constitutes a separately functioning and usable part of the Work that can be used by Owner for its intended purpose without significant interference with Contractor's performance of the remainder of the Work, subject to the following conditions:

1. Owner at any time may request Contractor in writing to permit Owner to use or occupy any such part of the Work which Owner believes to be ready for its intended use and substantially complete. If and when Contractor agrees that such part of the Work is substantially complete, Contractor, Owner, and Engineer will follow the procedures of Paragraph 14.04.A through D for that part of the Work.

2. Contractor at any time may notify Owner and Engineer in writing that Contractor considers any such part of the Work ready for its intended use and substantially complete and request Engineer to issue a certificate of Substantial Completion for that part of the Work.

3. Within a reasonable time after either such request, Owner, Contractor, and Engineer shall make an inspection of that part of the Work to determine its status of completion. If Engineer does not consider that part of the Work to be substantially complete, Engineer will notify

Owner and Contractor in writing giving the reasons therefor. If Engineer considers that part of the Work to be substantially complete, the provisions of Paragraph 14.04 will apply with respect to certification of Substantial Completion of that part of the Work and the division of responsibility in respect thereof and access thereto.

4. No use or occupancy or separate operation of part of the Work may occur prior to compliance with the requirements of Paragraph 5.10 regarding property insurance.

14.06 *Final Inspection*

A. Upon written notice from Contractor that the entire Work or an agreed portion thereof is complete, Engineer will promptly make a final inspection with Owner and Contractor and will notify Contractor in writing of all particulars in which this inspection reveals that the Work is incomplete or defective. Contractor shall immediately take such measures as are necessary to complete such Work or remedy such deficiencies.

14.07 *Final Payment*

A. *Application for Payment:*

1. After Contractor has, in the opinion of Engineer, satisfactorily completed all corrections identified during the final inspection and has delivered, in accordance with the Contract Documents, all maintenance and operating instructions, schedules, guarantees, bonds, certificates or other evidence of insurance, certificates of inspection, marked-up record documents (as provided in Paragraph 6.12), and other documents, Contractor may make application for final payment following the procedure for progress payments.

2. The final Application for Payment shall be accompanied (except as previously delivered) by:

- a. all documentation called for in the Contract Documents, including but not limited to the evidence of insurance required by Paragraph 5.04.B.6;
- b. consent of the surety, if any, to final payment;
- c. a list of all Claims against Owner that Contractor believes are unsettled; and
- d. complete and legally effective releases or waivers (satisfactory to Owner) of all Lien

rights arising out of or Liens filed in connection with the Work.

3. In lieu of the releases or waivers of Liens specified in Paragraph 14.07.A.2 and as approved by Owner, Contractor may furnish receipts or releases in full and an affidavit of Contractor that: (i) the releases and receipts include all labor, services, material, and equipment for which a Lien could be filed; and (ii) all payrolls, material and equipment bills, and other indebtedness connected with the Work for which Owner might in any way be responsible, or which might in any way result in liens or other burdens on Owner's property, have been paid or otherwise satisfied. If any Subcontractor or Supplier fails to furnish such a release or receipt in full, Contractor may furnish a bond or other collateral satisfactory to Owner to indemnify Owner against any Lien.

B. *Engineer's Review of Application and Acceptance:*

1. If, on the basis of Engineer's observation of the Work during construction and final inspection, and Engineer's review of the final Application for Payment and accompanying documentation as required by the Contract Documents, Engineer is satisfied that the Work has been completed and Contractor's other obligations under the Contract Documents have been fulfilled, Engineer will, within ten days after receipt of the final Application for Payment, indicate in writing Engineer's recommendation of payment and present the Application for Payment to Owner for payment. At the same time Engineer will also give written notice to Owner and Contractor that the Work is acceptable subject to the provisions of Paragraph 14.09. Otherwise, Engineer will return the Application for Payment to Contractor, indicating in writing the reasons for refusing to recommend final payment, in which case Contractor shall make the necessary corrections and resubmit the Application for Payment.

C. *Payment Becomes Due:*

1. Thirty days after the presentation to Owner of the Application for Payment and accompanying documentation, the amount recommended by Engineer, less any sum Owner is entitled to set off against Engineer's recommendation, including but not limited to liquidated damages, will become due and will be paid by Owner to Contractor.

14.08 *Final Completion Delayed*

A. If, through no fault of Contractor, final completion of the Work is significantly delayed, and if Engineer so confirms, Owner shall, upon receipt of

Contractor's final Application for Payment (for Work fully completed and accepted) and recommendation of Engineer, and without terminating the Contract, make payment of the balance due for that portion of the Work fully completed and accepted. If the remaining balance to be held by Owner for Work not fully completed or corrected is less than the retainage stipulated in the Agreement, and if bonds have been furnished as required in Paragraph 5.01, the written consent of the surety to the payment of the balance due for that portion of the Work fully completed and accepted shall be submitted by Contractor to Engineer with the Application for such payment. Such payment shall be made under the terms and conditions governing final payment, except that it shall not constitute a waiver of Claims.

14.09 *Waiver of Claims*

A. The making and acceptance of final payment will constitute:

1. a waiver of all Claims by Owner against Contractor, except Claims arising from unsettled Liens, from defective Work appearing after final inspection pursuant to Paragraph 14.06, from failure to comply with the Contract Documents or the terms of any special guarantees specified therein, or from Contractor's continuing obligations under the Contract Documents; and

2. a waiver of all Claims by Contractor against Owner other than those previously made in accordance with the requirements herein and expressly acknowledged by Owner in writing as still unsettled.

ARTICLE 15 – SUSPENSION OF WORK AND TERMINATION

15.01 *Owner May Suspend Work*

A. At any time and without cause, Owner may suspend the Work or any portion thereof for a period of not more than 90 consecutive days by notice in writing to Contractor and Engineer which will fix the date on which Work will be resumed. Contractor shall resume the Work on the date so fixed. Contractor shall be granted an adjustment in the Contract Price or an extension of the Contract Times, or both, directly attributable to any such suspension if Contractor makes a Claim therefor as provided in Paragraph 10.05.

15.02 *Owner May Terminate for Cause*

A. The occurrence of any one or more of the following events will justify termination for cause:

1. Contractor's persistent failure to perform the Work in accordance with the Contract Documents (including, but not limited to, failure to supply sufficient skilled workers or suitable materials or equipment or failure to adhere to the Progress Schedule established under Paragraph 2.07 as adjusted from time to time pursuant to Paragraph 6.04);

2. Contractor's disregard of Laws or Regulations of any public body having jurisdiction;

3. Contractor's repeated disregard of the authority of Engineer; or

4. Contractor's violation in any substantial way of any provisions of the Contract Documents.

B. If one or more of the events identified in Paragraph 15.02.A occur, Owner may, after giving Contractor (and surety) seven days written notice of its intent to terminate the services of Contractor:

1. exclude Contractor from the Site, and take possession of the Work and of all Contractor's tools, appliances, construction equipment, and machinery at the Site, and use the same to the full extent they could be used by Contractor (without liability to Contractor for trespass or conversion);

2. incorporate in the Work all materials and equipment stored at the Site or for which Owner has paid Contractor but which are stored elsewhere; and

3. complete the Work as Owner may deem expedient.

C. If Owner proceeds as provided in Paragraph 15.02.B, Contractor shall not be entitled to receive any further payment until the Work is completed. If the unpaid balance of the Contract Price exceeds all claims, costs, losses, and damages (including but not limited to all fees and charges of engineers, architects, attorneys, and other professionals and all court or arbitration or other dispute resolution costs) sustained by Owner arising out of or relating to completing the Work, such excess will be paid to Contractor. If such claims, costs, losses, and damages exceed such unpaid balance, Contractor shall pay the difference to Owner. Such claims, costs, losses, and damages incurred by Owner will be reviewed by Engineer as to their reasonableness and, when so approved by Engineer, incorporated in a Change Order. When exercising any rights or remedies under this Paragraph, Owner shall not be required to obtain the lowest price for the Work performed.

D. Notwithstanding Paragraphs 15.02.B and 15.02.C, Contractor's services will not be terminated if Contractor begins within seven days of receipt of notice of intent to terminate to correct its failure to perform and proceeds diligently to cure such failure within no more than 30 days of receipt of said notice.

E. Where Contractor's services have been so terminated by Owner, the termination will not affect any rights or remedies of Owner against Contractor then existing or which may thereafter accrue. Any retention or payment of moneys due Contractor by Owner will not release Contractor from liability.

F. If and to the extent that Contractor has provided a performance bond under the provisions of Paragraph 5.01.A, the termination procedures of that bond shall supersede the provisions of Paragraphs 15.02.B and 15.02.C.

15.03 *Owner May Terminate For Convenience*

A. Upon seven days written notice to Contractor and Engineer, Owner may, without cause and without prejudice to any other right or remedy of Owner, terminate the Contract. In such case, Contractor shall be paid for (without duplication of any items):

1. completed and acceptable Work executed in accordance with the Contract Documents prior to the effective date of termination, including fair and reasonable sums for overhead and profit on such Work;

2. expenses sustained prior to the effective date of termination in performing services and furnishing labor, materials, or equipment as required by the Contract Documents in connection with uncompleted Work, plus fair and reasonable sums for overhead and profit on such expenses;

3. all claims, costs, losses, and damages (including but not limited to all fees and charges of engineers, architects, attorneys, and other professionals and all court or arbitration or other dispute resolution costs) incurred in settlement of terminated contracts with Subcontractors, Suppliers, and others; and

4. reasonable expenses directly attributable to termination.

B. Contractor shall not be paid on account of loss of anticipated profits or revenue or other economic loss arising out of or resulting from such termination.

15.04 *Contractor May Stop Work or Terminate*

A. If, through no act or fault of Contractor, (i) the Work is suspended for more than 90 consecutive days by Owner or under an order of court or other public authority, or (ii) Engineer fails to act on any Application for Payment within 30 days after it is submitted, or (iii) Owner fails for 30 days to pay Contractor any sum finally determined to be due, then Contractor may, upon seven days written notice to Owner and Engineer, and provided Owner or Engineer do not remedy such suspension or failure within that time, terminate the Contract and recover from Owner payment on the same terms as provided in Paragraph 15.03.

B. In lieu of terminating the Contract and without prejudice to any other right or remedy, if Engineer has failed to act on an Application for Payment within 30 days after it is submitted, or Owner has failed for 30 days to pay Contractor any sum finally determined to be due, Contractor may, seven days after written notice to Owner and Engineer, stop the Work until payment is made of all such amounts due Contractor, including interest thereon. The provisions of this Paragraph 15.04 are not intended to preclude Contractor from making a Claim under Paragraph 10.05 for an adjustment in Contract Price or Contract Times or otherwise for expenses or damage directly attributable to Contractor's stopping the Work as permitted by this Paragraph.

ARTICLE 16 – DISPUTE RESOLUTION

16.01 *Methods and Procedures*

A. Either Owner or Contractor may request mediation of any Claim submitted to Engineer for a decision under Paragraph 10.05 before such decision becomes final and binding. The mediation will be governed by the Construction Industry Mediation Rules of the American Arbitration Association in effect as of the Effective Date of the Agreement. The request for mediation shall be submitted in writing to the American Arbitration Association and the other party to the Contract. Timely submission of the request shall stay the effect of Paragraph 10.05.E.

B. Owner and Contractor shall participate in the mediation process in good faith. The process shall be concluded within 60 days of filing of the request. The date of termination of the mediation shall be determined by application of the mediation rules referenced above.

C. If the Claim is not resolved by mediation, Engineer's action under Paragraph 10.05.C or a denial pursuant to Paragraphs 10.05.C.3 or 10.05.D shall become

final and binding 30 days after termination of the mediation unless, within that time period, Owner or Contractor:

1. elects in writing to invoke any dispute resolution process provided for in the Supplementary Conditions; or
2. agrees with the other party to submit the Claim to another dispute resolution process; or
3. gives written notice to the other party of the intent to submit the Claim to a court of competent jurisdiction.

ARTICLE 17 – MISCELLANEOUS

17.01 Giving Notice

A. Whenever any provision of the Contract Documents requires the giving of written notice, it will be deemed to have been validly given if:

1. delivered in person to the individual or to a member of the firm or to an officer of the corporation for whom it is intended; or
2. delivered at or sent by registered or certified mail, postage prepaid, to the last business address known to the giver of the notice.

17.02 Computation of Times

A. When any period of time is referred to in the Contract Documents by days, it will be computed to exclude the first and include the last day of such period. If the last day of any such period falls on a Saturday or Sunday or on a day made a legal holiday by the law of the applicable jurisdiction, such day will be omitted from the computation.

17.03 Cumulative Remedies

A. The duties and obligations imposed by these General Conditions and the rights and remedies available hereunder to the parties hereto are in addition to, and are not to be construed in any way as a limitation of, any rights and remedies available to any or all of them which are otherwise imposed or available by Laws or Regulations, by special warranty or guarantee, or by other provisions of the Contract Documents. The provisions of this Paragraph will be as effective as if repeated specifically in the Contract Documents in connection with each particular duty, obligation, right, and remedy to which they apply.

17.04 Survival of Obligations

A. All representations, indemnifications, warranties, and guarantees made in, required by, or given in accordance with the Contract Documents, as well as all continuing obligations indicated in the Contract Documents, will survive final payment, completion, and acceptance of the Work or termination or completion of the Contract or termination of the services of Contractor.

17.05 Controlling Law

A. This Contract is to be governed by the law of the state in which the Project is located.

17.06 Headings

A. Article and paragraph headings are inserted for convenience only and do not constitute parts of these General Conditions.

SUPPLEMENTARY CONDITIONS

REVISIONS AND ADDITIONS TO THE GENERAL CONDITIONS

The General Conditions are hereby revised as follows:

ARTICLE 1.01.A.19 "Engineer"

Add the following:

Wherever in these Documents the word "Engineer" appears, it shall be understood to mean the Construction Manager and their authorized representatives, acting either directly or indirectly as authorized agents of the Owner.

ARTICLE 1.01.A.29 "Owner"

Add the following:

Wherever in these Documents the word "Owner" appears, it shall be understood to mean the City of Key West whose address is 3140 Flagler Street, Key West, Florida 33040

SC-1.01.A.45. Supplement paragraph 1.01.A.43 of the General Conditions as follows:

Substantial Completion is further defined as (i) that degree of completion of the Project's operating facilities or systems sufficient to provide Owner the full time, uninterrupted, and continuous beneficial operation of the Work; and (ii) all required functional, performance and acceptance or startup testing has been successfully demonstrated for all components, devices, equipment, and instrumentation and control to the satisfaction of Engineer in accordance with the requirements of the Specifications.

SC-1.01.A.52. Add a new paragraph immediately following paragraph 1.01.A.52 of the General Conditions as follows:

1.01.A.53. *Specialist*—The term Specialist refers to a person, partnership, firm, or corporation of established reputation (or if newly organized, whose personnel have previously established a reputation in the same field), which is regularly engaged in, and which maintains a regular force of workers skilled in either (as applicable) manufacturing or fabricating items required by the Contract Documents, or otherwise performing Work required by the Contract Documents. Where the Specifications require the installation by a Specialist, that term shall also be deemed to mean either the manufacturer of the item, a person, partnership, firm, or corporation licensed by the manufacturer, or a person, partnership, firm, or corporation who will perform the Work under the manufacturer's direct supervision.

SC-2.03.A. Delete the third sentence of paragraph 2.03.A *Commencement of Contract Times: Notice to Proceed* of the General Conditions in its entirety.

ARTICLE 4.05 "REFERENCE POINTS"

Add the following:

It will be the Contractor's responsibility to layout the work and to transfer elevations from benchmarks. Where new construction connects to existing facilities, the Contractor shall check and establish the exact location prior to construction of the facilities.

The Contractor shall furnish all surveys, labor, and equipment, including setting all alignment and gradient, grade stakes, batter boards, and everything necessary to lay out his work. The Contractor shall be responsible for maintaining and re-establishing at his expense, all control points. After completion of his construction, he shall reset all permanent monuments at their original locations and elevations.

All layout work may be checked by the Engineer, and the Contractor shall furnish all necessary labor, equipment, and materials, and shall cooperate and assist the Engineer in making such checks.

The dimensions for lines and elevations for grades of the structures, appurtenances, and utilities will be shown on Drawings, together with other pertinent information required for laying out the work. If site conditions vary from those indicated, the Contractor shall notify the Engineer immediately, who will make any minor adjustment as required.

ARTICLE 5.03 "CERTIFICATES OF INSURANCE"

5.03.B. Delete 5.03.B in its entirety.

ARTICLE 5.04 "CONTRACTOR'S LIABILITY INSURANCE"

5.04.A and 5.04.B Delete 5.04.A and 5.04.B in their entirety and Add the following:

A. CONTRACTOR is to secure, pay for, and file with the City of Key West, prior to commencing any work under the Contract, all certificates for Workers' Compensation, Public Liability, and Property Damage Liability Insurance and such other insurance coverages as may be required by specifications and addenda thereto, in at least the following minimum amounts with specification amounts to prevail if greater than minimum amounts indicated. Notwithstanding any other provision of the Contract, the CONTRACTOR shall provide the minimum limits of liability insurance coverages as follows:

Auto Liability	\$1,000,000	Combined Single Limit
General Liability	\$2,000,000	Aggregate (Per Project)
	\$2,000,000	Products Aggregate
	\$1,000,000	Any One Occurrence
	\$1,000,000	Personal Injury
	\$ 300,000	Fire Damage/Legal
Additional Umbrella Liability	\$2,000,000	Occurrence/Aggregate

- B. CONTRACTOR shall furnish an original Certificate of Insurance indicating, and such policy providing coverage to, City of Key West named as “Additional Insured” on PRIMARY and NON CONTRIBUTORY basis utilizing an ISO standard endorsement at least as broad as CG 2010 (11/85) or its Equivalent, (COMBINATION of CG 20 10 07 04 and CG 20 37 07 04, providing coverage for completed operations is acceptable) INCLUDING a “Waiver of Subrogation” clause in favor of City of Key West on all policies. CONTRACTOR will maintain the General Liability and Umbrella Liability insurance coverages summarized above with coverage continuing in full force including the “additional insured” endorsement until at least 3 years beyond completion and delivery of the work contracted herein.
- C. Notwithstanding any other provision of the Contract, the CONTRACTOR shall maintain complete Workers’ Compensation coverage for each and every employee, principal, officer, representative, or agent of the CONTRACTOR who is performing any labor, services, or material under the Contract. Further, CONTRACTOR shall additionally maintain the following minimum limits of coverage:
- | | |
|--|-------------|
| Bodily Injury Each Accident | \$1,000,000 |
| Bodily Injury by Disease Each Employee | \$1,000,000 |
| Bodily Injury by Disease Policy Limit | \$1,000,000 |
- D. CONTRACTOR’s insurance policies shall be endorsed to give 30 days’ written notice to the City of Key West in the event of cancellation or material change, using form CG 02 24, or its equivalent.
- E. Certificates of Insurance submitted to the City of Key West will not be accepted without copies of the endorsements being requested. This includes additional insured endorsements, cancellation/material change notice endorsements, and waivers of subrogation. Copies of USL&H Act and Jones Act endorsements will also be required if necessary. PLEASE ADVISE YOUR INSURANCE AGENT ACCORDINGLY.
- F. CONTRACTOR will comply with any and all safety regulations required by any agency or regulatory body including but not limited to OSHA. CONTRACTOR will notify City of Key West immediately by telephone at 305-809-3811 of any accident or injury to anyone that occurs on the jobsite and is related to any of the work being performed by the CONTRACTOR.

G. SAMPLE ENDORSEMENTS REQUIRED BY ARTICLE 34 ARE INCLUDED IN BID PACKAGE AS EXHIBITS A-F to these supplementary conditions.

H. INDEMNIFICATION

1. To the fullest extent permitted by law, the CONTRACTOR expressly agrees to indemnify and hold harmless the City of Key West, their officers, directors, agents and employees (herein called the “indemnitees”) from liabilities, damages, losses and costs, including but not limited to, reasonable attorney’s fees and court costs, such legal expenses to include costs incurred in establishing the indemnification and other rights agreed to in this Paragraph, to persons or property, to the extent caused by the negligence, recklessness, or intentional wrongful misconduct of the CONTRACTOR, its Subcontractors or persons employed or utilized by them in the performance of the Contract. Claims by indemnitees for indemnification shall be limited to the amount of CONTRACTOR’s insurance or \$1 million per occurrence, whichever is greater. The parties acknowledge that the amount of the indemnity required hereunder bears a reasonable commercial relationship to the Contract and it is part of the project specifications or the bid documents, if any.
2. The indemnification obligations under the Contract shall not be restricted in any way by any limitation on the amount or type of damages, compensation, or benefits payable by or for the CONTRACTOR under Workers’ Compensation acts, disability benefits acts, or other employee benefits acts, and shall extend to and include any actions brought by or in the name of any employee of the CONTRACTOR or of any third party to whom CONTRACTOR may subcontract a part or all of the Work. This indemnification shall continue beyond the date of completion of the work.

I. SURETY AND INSURER QUALIFICATIONS

1. All bonds, insurance contracts, and certificates of insurance shall be either executed by or countersigned by a licensed resident agent of the Surety or insurance company, having his place of business in the State of Florida, and in all ways complying with the insurance laws of the State of Florida. Further, the said Surety or insurance company shall be duly licensed and qualified to do business in the State of Florida.

ARTICLE 5.04 “CONTRACTOR’S LIABILITY INSURANCE”

Include the City of Key West and CH2M HILL as additional insureds.

ARTICLE 5.05 “OWNER’S LIABILITY INSURANCE”

5.05 Delete Article 5.05 in its entirety.

ARTICLE 5.06 “PROPERTY INSURANCE”

5.06 Delete Article 5.06 in its entirety.

ARTICLE 5.07 “WAIVER OF RIGHTS”

5.07.A. Delete Article 5.07.A in its entirety and Replace with the following:

A. CONTRACTOR waives all rights against the OWNER, respective of officers, directors, partners, employees, agents, consultants and subcontractors of each and any of them for all losses and damages caused by, arising out of or resulting from any of the perils or causes of loss covered by such policies and any other property insurance applicable to the Work; and, in addition, waive all rights against the Engineer, and all other individuals or entities identified in the Supplementary Conditions to be listed as insured or additional insured (and the officers, directors, partners, employees, agents, consultants and subcontractors of each and any of them) under such policies for losses and damages so accused.

5.07.B. Delete Article 5.07.B. in its entirety.

5.07.C. Delete Article 5.07.C. in its entirety

ARTICLE 5.08 “RECEIPT AND APPLICATION OF INSURANCE PROCEEDS”

Delete Article 5.08 in its entirety.

ARTICLE 5.09 “ACCEPTANCE OF BONDS AND INSURANCE”

Delete 5.09 in its entirety and replace with the following:

If Owner has any objection to the coverage afforded by Contractor or other provisions of the bonds or insurance required to be purchased and maintained by the Contractor in accordance with Article 5 on the basis of non-conformance with the Contract Documents, the Owner shall so notify the Contractor in writing within 7 days after receipt of the certificates (or other evidence requested) required by Paragraph 2.01.B. Contractor shall provide to the Owner such additional information in respect of insurance as Owner may reasonable request. If Contractor does not purchase or maintain all of the bonds and insurance required of Contractor by the Contract Documents, owner shall notify Contractor in writing of such failure to purchase prior

to the start of the Work, or of such failure to maintain prior to any change in the required coverage. Without prejudice to any other right or remedy, the Contractor may elect to obtain equivalent bonds or insurance to protect Owner's interest at the expense of the Contractor who was required to provide such coverage, and a Change Order shall be issued to adjust the Contract Price accordingly.

ARTICLE 5.10 "Partial Utilization, Acknowledgement of Property Insurer"

Delete Article 5.10 in its entirety.

ARTICLE 6.09 "LAWS AND REGULATIONS"

Add the following:

The Contractor shall comply with the City of Key West Noise Ordinance.

ARTICLE 6.09 "LAWS AND REGULATIONS"

Add the following subarticles:

Within 10 days of Notice of Award, the successful Bidder must represent that he holds all applicable state, county, and City of Key West licenses and permits required to do business as a contractor with respect to the work described in the Contract Documents.

Further, the successful Bidder must, within 10 days of Notice of Award, furnish documentation showing that, as a minimum, he has complied with the provisions of Chapter 91 of the Code of Ordinances of the City of Key West in order to enter into the Agreement contained in the Contract Documents.

Specifically, within 10 days after Notice of Award, the successful Bidder must demonstrate that he holds, as a minimum, the following licenses and certificates:

- A. All licenses or certificates required by federal, state, or local statutes or regulations.
- B. Holds a valid Certificate of Competency issued by the Public Service Director of the Building and Zoning Department which shall be valid throughout the Contract time.
- C. Holds a valid occupational license issued by the City of Key West.

FOLLOWING ARTICLE 6.09 "LAWS AND REGULATIONS"

Add the following Article:

HISTORIC PRESERVATION

The Contractor shall comply with Florida's Archives and Historic Act (Florida Statutes, Chapter 267) and the regulations of the local historic preservation board as applicable and protect against the potential loss or destruction of significant historical or archaeological data, sites, and properties in connection with the project.

ARTICLE 6.13 "SAFETY AND PROTECTION"

Add the following Subarticle:

OCCUPATIONAL SAFETY AND HEALTH

The Contractor and its Sub-Contractors shall observe and comply with all applicable local, state, and federal occupational safety and health regulations during the prosecution of work under this Contract. In addition, full compliance by the Contractor with the U.S. Department of Labor's Occupational Safety and Health Standards, as established in Public Law 91-596, will be required under the terms of this Contract.

ARTICLE 6.20 "INDEMNIFICATION"

Delete Article 6.20 in its entirety and replace with the following:

- A. To the fullest extent permitted by law, the CONTRACTOR expressly agrees to indemnify and hold harmless the City of Key West, their officers, directors, agents and employees (herein called the "indemnitees") from liabilities, damages, losses and costs, including but not limited to, reasonable attorney's fees and court costs, such legal expenses to include costs incurred in establishing the indemnification and other rights agreed to in this Paragraph, to persons or property, to the extent caused by the negligence, recklessness, or intentional wrongful misconduct of the CONTRACTOR, its Subcontractors or persons employed or utilized by them in the performance of the Contract. Claims by indemnitees for indemnification shall be limited to the amount of CONTRACTOR's insurance or \$1 million per occurrence, whichever is greater. The parties acknowledge that the amount of the indemnity required hereunder bears a reasonable commercial relationship to the Contract and it is part of the project specifications or the bid documents, if any.

- B. The indemnification obligations under the Contract shall not be restricted in any way by any limitation on the amount or type of damages, compensation, or benefits payable by or for the CONTRACTOR under Workers' Compensation acts, disability benefits acts, or other employee benefits acts, and shall extend to and include any actions brought by or in the name of any employee of the CONTRACTOR or of any third party to whom CONTRACTOR may subcontract a part or all of the Work. This indemnification shall continue beyond the date of completion of the work.

ARTICLE 13.03 "TESTS AND INSPECTIONS"

SC-13.03.B Delete 13.03.B in its entirety and insert the following:

Contractor shall employ and pay for the services of an independent testing laboratory to perform all inspections, tests, or approvals required by the Contract Documents.

SC-13.03.D. Supplement paragraph 13.03.D of the General Conditions as follows:

Tests required by Contract Documents to be performed by Contractor that require test certificates be submitted to Owner or Engineer for acceptance shall be made by an independent testing laboratory or agency licensed or certified in accordance with Laws and Regulations and applicable state and local statutes. In the event state license or certification is not required, testing laboratories or agencies shall meet following applicable requirements:

13.03.D.1. "Recommended Requirements for Independent Laboratory Qualification," published by the American Council of Independent Laboratories.

13.03.D.2. Basic requirements of ASTM E329, "Standard Specification for Agencies Engaged in the Testing and/or Inspection of Materials Used in Construction" as applicable.

13.03.D.3. Calibrate testing equipment at reasonable intervals by devices of accuracy traceable to either the National Bureau of Standards or accepted values of natural physical constants.

ARTICLE 13.07 "CORRECTION PERIOD"

13.07.A. Change the first sentence from "If within one year after the date of Substantial Completion..." TO "If within five years after the date of Substantial Completion..."

13.07.D. Change the sentence from "...will be extended for an additional period of one year after such corrections or removal..." TO "...will be extended for an additional period of five years after such correction or removal..."

ARTICLE 14 "PAYMENTS TO CONTRACTOR AND COMPLETION"

Add the following to the end of Subarticle 14.02.B.1:

Add the following subarticles:

14.02.B1.1 The Owner will deduct from the estimate, and retain as part security, 10 percent of the amount earned for work satisfactorily completed. A deduction and retainage of 10 percent will be made on the estimated amount earned for approved items of material delivered to and properly stored at the jobsite but not incorporated into the work.

14.02.B1.2 After deducting the retainage and the amount of all previous partial payments made to the Contractor from the amount earned, the amount due will be made payable to the Contractor. Recommendations for payment received by the Owner less than 40 days prior to the scheduled day for payment will not be processed or paid until the following month.

CERTIFICATION REGARDING DEBARMENT, SUSPENSION, INELIGIBILITY, AND VOLUNTARY EXCLUSION – LOWER TIER COVERED TRANSACTIONS

Note: This certification/clause has been extracted from Appendix B to 40 CFR Part 32 and is applicable to all goods and services (including construction) contracts and subcontracts with a price equaling or exceeding \$25,000 and in all solicitations for such contracts and subcontracts.

Instructions for Certification:

1. By signing and submitting this Proposal, the prospective lower tier participant is providing the certification set out below.
2. The certification in this clause is a material representation of fact upon which reliance was placed when this transaction was entered into. If it is later determined that the prospective lower tier participant knowingly rendered an erroneous certification, in addition to other remedies available to the Federal Government, the department or agency with which this transaction originated may pursue available remedies, including suspension and/or debarment.
3. The prospective lower tier participant shall provide immediate written notice to the person to which this Proposal is submitted if at any time the prospective lower tier participant learns that its certification was erroneous when submitted or has become erroneous by reason of changed circumstances.

4. The terms “covered transaction,” “debarred,” “suspended,” “ineligible,” “lower tier covered transaction,” “participant,” “person,” “primary covered transaction,” “principal,” “proposal,” and “voluntarily excluded,” as used in this clause, have the meanings set out in the Definitions and Coverage sections of rules implementing Executive Order 12549. You may contact the person to which this Proposal is submitted for assistance in obtaining a copy of those regulations.
5. The prospective lower tier participant agrees by submitting this Proposal that, should the proposed covered transaction be entered into, it shall not knowingly enter into any lower tier covered transaction with a person who is debarred, suspended, declared ineligible, or voluntarily excluded from participation in this covered transaction, unless authorized by the department or agency with which this transaction originated.
6. The prospective lower tier participant further agrees by submitting this Proposal that it will include this clause titled “Certification Regarding Debarment, Suspension, Ineligibility and Voluntary Exclusion-Lower Tier Covered Transactions,” without modification, in all lower tier covered transactions and in all solicitations for lower tier covered transactions.
7. A participant in a covered transaction may rely upon a certification of a prospective participant in a lower tier covered transaction that it is not debarred, suspended, ineligible, or voluntarily excluded from the covered transaction, unless it knows that the certification is erroneous. A participant may decide the method and frequency by which it determines the eligibility of its principals. Each participant may, but is not required to, check the Nonprocurement List.
8. Nothing contained in the foregoing shall be construed to require establishment of a system of records in order to render in good faith the certification required by this clause. The knowledge and information of a participant is not required to exceed that which is normally possessed by a prudent person in the ordinary course of business dealings.
9. Except for transactions authorized under paragraph 5 of these instructions, if a participant in a covered transaction knowingly enters into a lower tier covered transaction with a person who is suspended, debarred, ineligible, or voluntarily excluded from participation in this transaction, in addition to other remedies available to the Federal Government, the department or agency with which this transaction originated may pursue available remedies, including suspension and/or debarment.

SUPPLEMENTS

- A. The supplements listed below, following “END OF SECTION,” are part of this Specification.
1. Exhibit A: Certificate of Liability Insurance.
 2. Exhibit B: Additional Insured-Owner’s, Lessees or Contractors-Scheduled Person or Organization.
 3. Exhibit C: Additional Insured-Owner’s, Lessees or Contractors-Completed Operations.
 4. Exhibit D: Earlier Notice of Cancellation Provided by Us.
 5. Exhibit E: Waiver of Transfer of Rights of Recovery Against Others to Us.
 6. Exhibit F: Waiver of Our Right to Recover from Others Endorsement
 7. Exhibit G: Rapid Gate: Tenant Brief: NAS Key West.

END OF SECTION

POLICY NUMBER:

COMMERCIAL GENERAL LIABILITY
CG 20 10 07 04

THIS ENDORSEMENT CHANGES THE POLICY. PLEASE READ IT CAREFULLY.

**ADDITIONAL INSURED – OWNERS, LESSEES OR
CONTRACTORS – SCHEDULED PERSON OR
ORGANIZATION**

This endorsement modifies insurance provided under the following:

COMMERCIAL GENERAL LIABILITY COVERAGE PART

SCHEDULE

Name Of Additional Insured Person(s) Or Organization(s):	Location(s) Of Covered Operations
Information required to complete this Schedule, if not shown above, will be shown in the Declarations.	

A. Section II – Who Is An Insured is amended to include as an additional insured the person(s) or organization(s) shown in the Schedule, but only with respect to liability for "bodily injury", "property damage" or "personal and advertising injury" caused, in whole or in part, by:

1. Your acts or omissions; or
2. The acts or omissions of those acting on your behalf;

in the performance of your ongoing operations for the additional insured(s) at the location(s) designated above.

B. With respect to the insurance afforded to these additional insureds, the following additional exclusions apply:

This insurance does not apply to "bodily injury" or "property damage" occurring after:

1. All work, including materials, parts or equipment furnished in connection with such work, on the project (other than service, maintenance or repairs) to be performed by or on behalf of the additional insured(s) at the location of the covered operations has been completed; or
2. That portion of "your work" out of which the injury or damage arises has been put to its intended use by any person or organization other than another contractor or subcontractor engaged in performing operations for a principal as a part of the same project.

POLICY NUMBER:

COMMERCIAL GENERAL LIABILITY
CG 20 37 07 04

THIS ENDORSEMENT CHANGES THE POLICY. PLEASE READ IT CAREFULLY.

**ADDITIONAL INSURED – OWNERS, LESSEES OR
CONTRACTORS – COMPLETED OPERATIONS**

This endorsement modifies insurance provided under the following:

COMMERCIAL GENERAL LIABILITY COVERAGE PART

SCHEDULE

Name Of Additional Insured Person(s) Or Organization(s):	Location And Description Of Completed Operations
Information required to complete this Schedule, if not shown above, will be shown in the Declarations.	

Section II – Who Is An Insured is amended to include as an additional insured the person(s) or organization(s) shown in the Schedule, but only with respect to liability for "bodily injury" or "property damage" caused, in whole or in part, by "your work" at the location designated and described in the schedule of this endorsement performed for that additional insured and included in the "products-completed operations hazard".

THIS ENDORSEMENT CHANGES THE POLICY. PLEASE READ IT CAREFULLY.

**EARLIER NOTICE OF CANCELLATION
PROVIDED BY US**

Number of Days Notice 30

For any statutorily permitted reason **other than nonpayment of premium**, the number of days required for notice of cancellation is increased to the number of days shown in the Schedule above.

If this policy is cancelled by us we will send the Named Insured and any party listed in the following schedule notice of cancellation based on the number of days notice shown above.

Schedule

Name of Person or Organization

Mailing Address

POLICY NUMBER:

COMMERCIAL GENERAL LIABILITY
CG 24 04 05 09

WAIVER OF TRANSFER OF RIGHTS OF RECOVERY AGAINST OTHERS TO US

This endorsement modifies insurance provided under the following:

COMMERCIAL GENERAL LIABILITY COVERAGE PART
PRODUCTS/COMPLETED OPERATIONS LIABILITY COVERAGE PART

SCHEDULE

Name Of Person Or Organization:
Information required to complete this Schedule, if not shown above, will be shown in the Declarations.

The following is added to Paragraph 8. Transfer Of Rights Of Recovery Against Others To Us of Section IV – Conditions:

We waive any right of recovery we may have against the person or organization shown in the Schedule above because of payments we make for injury or damage arising out of your ongoing operations or "your work" done under a contract with that person or organization and included in the "products-completed operations hazard". This waiver applies only to the person or organization shown in the Schedule above.

WAIVER OF OUR RIGHT TO RECOVER FROM OTHERS ENDORSEMENT

We have the right to recover our payments from anyone liable for an injury covered by this policy. We will not enforce our right against the person or organization named in the Schedule. (This agreement applies only to the extent that you perform work under a written contract that requires you to obtain this agreement from us.)

This agreement shall not operate directly or indirectly to benefit anyone not named in the Schedule.

Schedule

This endorsement changes the policy to which it is attached and is effective on the date issued unless otherwise stated.

(The information below is required only when this endorsement is issued subsequent to preparation of the policy.)

Endorsement
Insured

Effective Policy No.

Endorsement No.
Premium

Insurance Company

Countersigned by _____

WC 00 03 13
(Ed. 4-84)

RAPIDGate Tenant Brief NAS Key West

Matt Faletti

Director

Government Affairs Group

Amber Phelps

Regional Program Manager

Government Affairs Group



The *RAPIDGate* Program

"Enterprise Solution for Identity Management and Perimeter Installation Access Control Designed to Manage non-CAC Eligible Vendors, Contractors, Sub-contractors, Suppliers, and Service Providers."

- *The RAPIDGate* Program supports US Navy efforts to comply with:
 - HSPD 12 Policy for a Common Identification Standard for Federal Employees and Contractors
 - Public Law 110-181 (FY 2008) SEC 1069 Standards for Entry to Military Installations in (the) United States
 - USNORTHCOM Installation Access Control Guidance in the AOR, dtd 05 DEC 2007
 - Federal Information Processing Standards Publication (FIPS) 201-1 Personal Identity Verification (PIV) of Federal Employees and Contractors, dtd MAR 2006
 - DoD Instruction (DoDI) 2000.16 DoD Anti-Terrorism Standards , dtd 02 OCT 2006
 - DoDI 5200.08-R Physical Security Program, dtd APR 2007
 - Directive Type Memorandum (DTM) 09-12 Interim Policy Guidance for DoD Physical Access, dtd 08 DEC 2009
 - OPNAV Instruction 5530.14 Navy Physical Security and Law Enforcement Program, dtd 28 JAN 2009
 - OPNAV Instruction 1752.3 Policy for Sex Offender Tracking, Assignment and Access Restrictions with the Navy, dtd 27 May 2009
 - MEMORANDUM FOR COMMANDANT OF THE MARINE CORPS CHIEF OF NAVAL OPERATIONS

The *RAPID*Gate Installation Program Benefits

- Standardized enrollment, vetting, credentials and control of access privileges for all vendors, contractors, sub-contractors, suppliers and service providers coming aboard CNIC installations **not eligible for a CAC**
- Improved the safety and security of CNIC installations through the continuous vetting and “in near real time” the electronic verification of credentials & access privileges of vendors/contractors coming aboard CNIC installations
- Improved efficiencies at Pass & ID through a reduction in the issuance of contractor passes and other locally produced credentials

The *RAPID*Gate Installation Program Benefits

- Improve access control security when admitting vendors/contractors by reducing the number and types of perimeter access credentials.
- Improve installation and tenant organization security through the management of vendors/contractors by a single system
- Lower overhead of CNIC and other Commands through the reduction of and/or elimination of the purchase and/or annual sustainment of existing locally produced credentialing systems
- NEXCOM fully supports CNIC Navy Notice and *RAPID*Gate SOP for the vendors/contractors who serve their facilities to create a “trusted” vendor/contractor and support their loss prevention program

The *RAPID*Gate Program Capabilities

*RAPID*Gate®

Electronically Verify & Biometrically Authenticate

- Self-Registration
- Vetting – comprehensive initial background screening and regular re-screening
- Credentialing – manufacturing, shipping, issuance and lifecycle management
- Access Control– Electronically verify & biometrically authenticate in near real-time identities & credentials
- Access Privileges – Authoritative data repository (ADR) local ECP servers updated every 30 minutes
- Reporting – Monthly activity and ad hoc reports



The *RAPID*Gate Program Participants

- **Participants**

- ✓ Vendors
- ✓ Contractors
- ✓ Sub-contractors
- ✓ Suppliers
- ✓ Service Providers

- **Regardless of how personnel come onto the installation**

- ✓ Walk
- ✓ Cars
- ✓ Pick-ups
- ✓ Vans
- ✓ Trucks/Semi-trucks



The *RAPID*Gate Program Enrollment

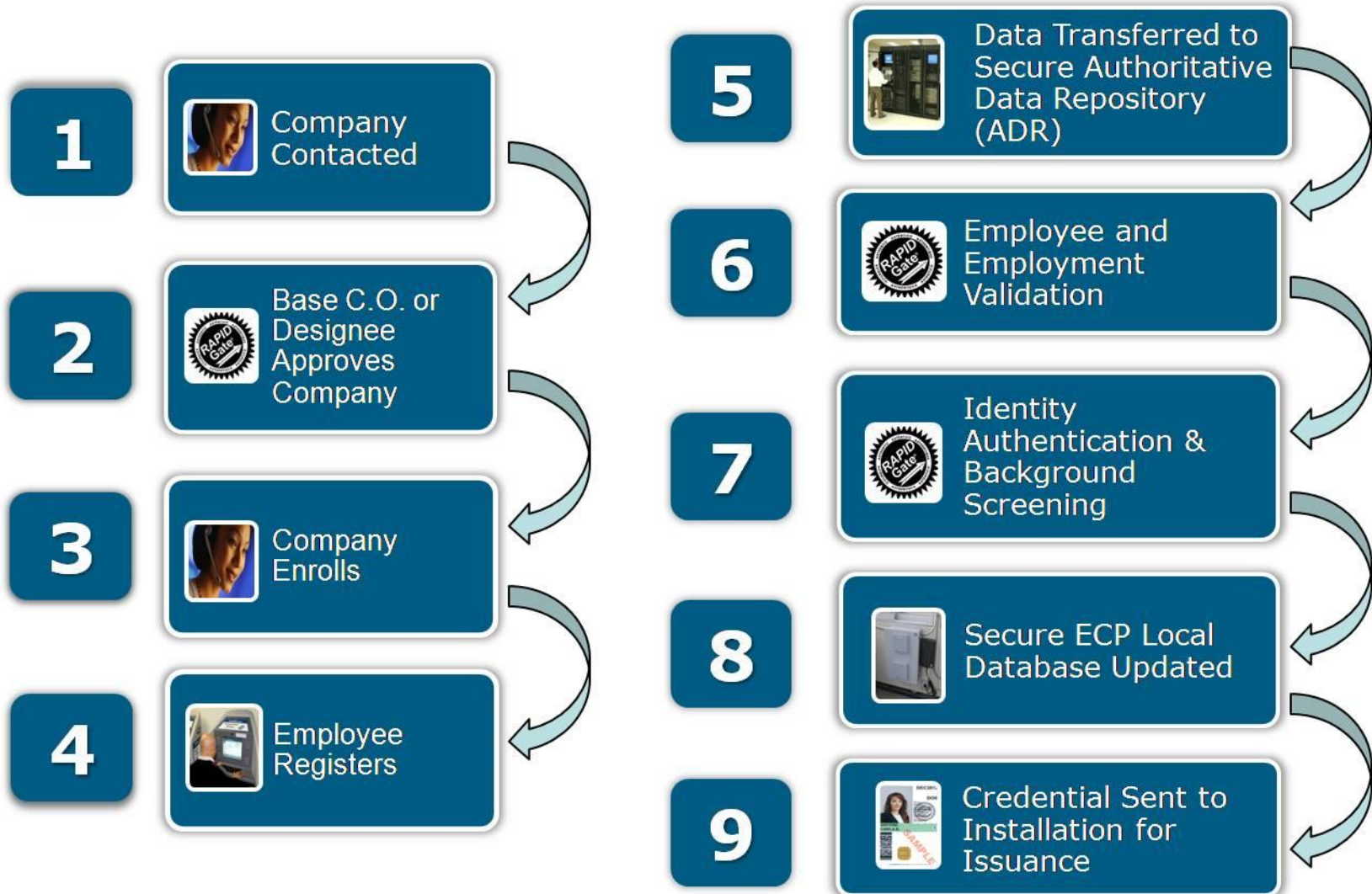

The RAPIDGate Program Enforcement



The *RAPID*Gate Program Vetting

▪ **Initial Vetting**

- ✓ Identity Validation
- ✓ 10 Year Address History
- ✓ Electronic Database Vetting
- ✓ SSN Trace

▪ **Program Disqualifiers**

- ✓ Any Felony Conviction
- ✓ Registered Sexual Offender
- ✓ Any Outstanding Criminal Warrant
- ✓ National Criminal Database hit

▪ **Credential Issuance**

- ✓ I-9 Document Check at Issuance
- ✓ No-entry, Debarment, No Work Lists
- ✓ Issued by Government personnel

▪ **Ongoing**

- ✓ Watchdog Electronic Re-vetting Every 92 days



The *RAPID*Gate Program Sample Disqualification Summary

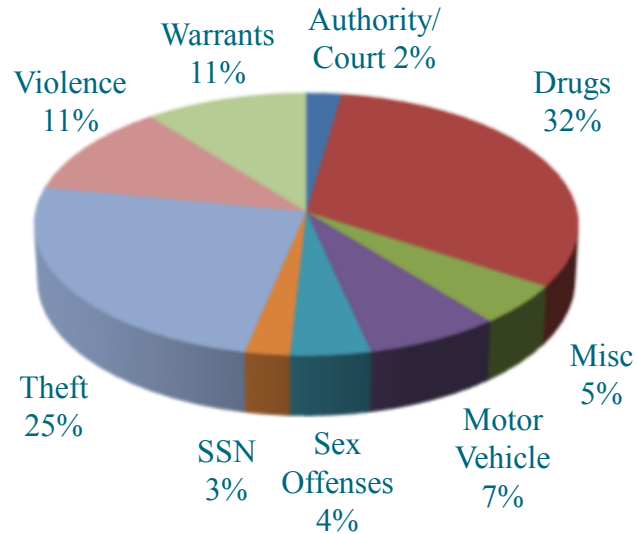

*RAPID*Gate Program
Life-to-Date Vetting
Has Experienced a
4.13% Disqualification
Rate

Actual Disqualification Examples (All Convictions are Felonies):

- Registered Sex Offender
- Invalid Social Security Number
- Auto Theft
- Burglary/Robbery
- Counterfeit Access Cards
- Embezzlement/Extortion/Forgery/Fraud
- Assault with a Deadly Weapon
- Assault on a Peace Officer
- Attempted Murder
- Cruelty to a Child
- Outstanding Warrants
- Escape By State Prison Inmate
- Drug Violations (Meth, Cocaine, Heroin)
- Permit Minors to Consume Alcohol
- Bringing in Illegal Aliens
- Firearm Violations
- Conspiracy to Commit Offenses Against the US
- Kidnapping
- Malicious Destruction of Property
- Stalking
- Vandalism
- Preventing Witness From Testifying
- DUI and Gross Vehicular Manslaughter
- Fleeing and Eluding

The *RAPIDGate* Program Hardware & Credential

REGISTRATION STATION



- Multi-Language
- Digital Camera
- Fingerprint Scanner
- ADA Compliant

HANDHELD DEVICE



- Mag stripe reader
- 2D barcode reader
- Fingerprint scanner
- Color display
- Easy to read
- Battery status
- 802.11G wireless connectivity to the guard station

GUARD STATION



- UPS
- Locked enclosure

RAPIDGate CREDENTIAL

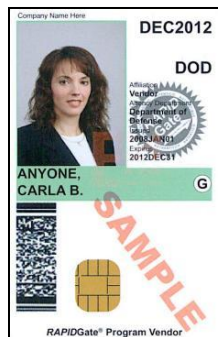

- Credential uses FIPS 201-1
- GSA approved product
- List cardstock and follows NIST SP800-104 topography recommendations

HANDHELD CHARGERS AND CRADLES



- Battery indicator light
- Easy to use
- Spare Batteries

Vendor and Contractor NAS Key West Access Changes

- **General SOPs:**
 - Existing Contractor Passes will maintain their existing expiration date
 - Manufacturing of new Contractor Passes will stop on 01 OCT
- ***RAPIDGate* Participants:**
 - Subject to random inspections
 - Access permitted through all gates during the necessary business hours
- **Contractor ID/Short-term ID**
 - Mandatory Inspections
 - Inspections will only occur Mon-Fri 7:00am – 10:00am at the Commercial Gate. Access will be denied outside of those hours if a *RAPIDGate* Credential is not used.
 - All inspections will occur at the Commercial Gate no matter which annex is being accessed

The *RAPID*Gate Program Shared Responsibilities

- **Eid Passport**

- ✓ Owns, updates and maintains hardware and software
- ✓ Trains force protection personnel and other affected Government employees
- ✓ Contacts vendors/contractors and maintains that relationship throughout Program

- **Vendor/Contractor Company**

- ✓ Company funds Program participation

- **Government**

- ✓ Provides electricity, phone connectivity, space, credential issuance and Program support
- ✓ Support implementation and ongoing management of the Program

Role of Tenant Sponsors

- **Approve authorized companies**
 - Provide company contact and Access Privileges
 - Respond to request for approval for companies not on the approved list
 - Review list of approved companies on monthly basis and provide changes/updates
- **Deactivate unauthorized companies**
 - Just call 1-877-RAPIDGate for immediate deactivation
- **Help companies take advantage of the program**
 - We can help you help the vendors; Direct them to 1-877-RAPIDGate
- **Support of the installation security changes**

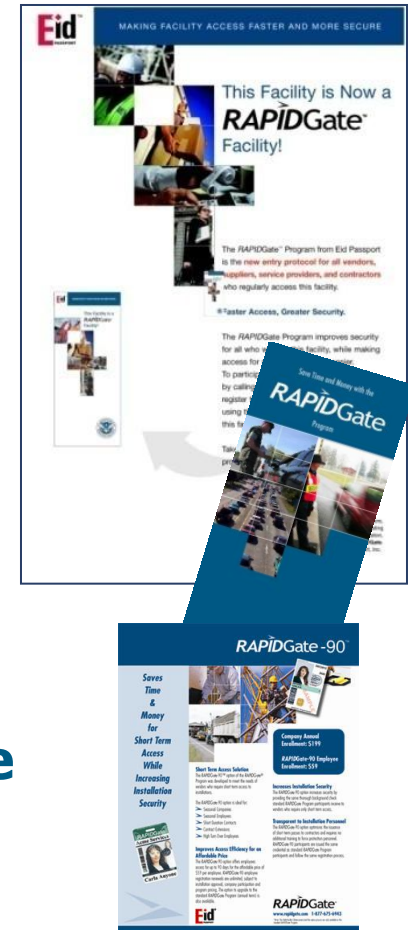

The *RAPIDGate* Program Options

- ***RAPIDGate* Enterprise Option**

- ✓ One credential
- ✓ Same installation access process
- ✓ Access privileges for multiple installations as approved by Installation Commanding Officers

- ***RAPIDGate-90*® Option**

- ✓ Access for up to 90 days
- ✓ Same registration, background screen and credential
- ✓ Designed for:
 - Seasonal companies & employees
 - Short duration contracts & contract extensions
 - Probationary employees and high turn-over workforces

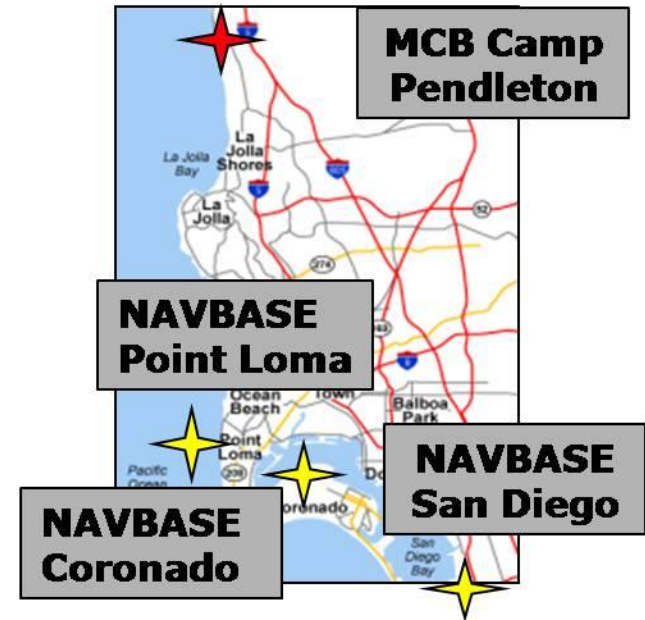

The *RAPID*Gate Program Pricing

Program	Enrollment	Price
<i>RAPID</i>Gate Program (single installation)	Company	\$199 annually
<i>RAPID</i>Gate Program (single installation)	Employee	\$159 annually
<i>RAPID</i>Gate Enterprise (multiple installations)	Company	\$249 annually 2 or more installations
<i>RAPID</i>Gate Enterprise (multiple installations)	Employee	\$199 annually 2 or more installations
<i>RAPID</i>Gate-90	Employee	\$59 per 90 days
Replacement Credential	Employee	\$30 per credential

Role of Tenant Sponsors

- **Approve authorized companies**
 - Provide company contact and Access Privileges
 - Respond to request for approval for companies not on the approved list
 - Review list of approved companies on monthly basis and provide changes/updates
- **Deactivate unauthorized companies**
 - Just call 1-877-RAPIDGate for immediate deactivation
- **Help companies take advantage of the program**
 - We can help you help the vendors; Direct them to 1-877-RAPIDGate
- **Support of the installation security changes**

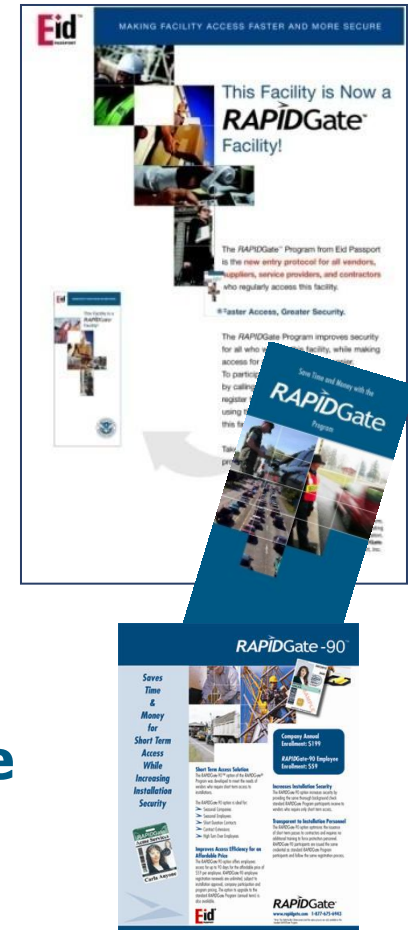

The *RAPID*Gate Program

Questions?

PART 3

SPECIFICATIONS

**SECTION 01 01 00
GENERAL REQUIREMENTS**

PART 1 PROJECT DESCRIPTION

1.01 GENERAL

- A. A brief description of the Work is stated in the Invitation to Bid. To determine the full scope of the Project or any particular part of the Project, coordinate the applicable information in the several parts of these Contract Documents.
- B. The Work under this Contract shall be performed by the Contractor as required by the Owner. Work will be authorized in the form of a Notice to Proceed issued to the Contractor. The Contractor shall complete all Work in the Contract within the number of calendar days stipulated in the Contract unless an extension in the time of completion is granted by the Engineer, as stated in the Instructions to Bidders. Upon completion of the Work and compliance with applicable provisions in the Contract Documents, the Contractor will receive final payment for all Work done.
- C. The following additional information, though not all-inclusive, is given to assist contractors in their evaluation of the Work required to meet the Project objectives.
- D. This Project will provide Owner with a permanent finished roof system with lightning protection for the upper portion of the Administration Building and the Chlorine Building at the Richard A. Heyman Environmental Protection Facility.

PART 2 SEQUENCE OF OPERATIONS

2.01 SCHEDULING

- A. General:
 - 1. Submit estimated progress schedule and preliminary schedule of submittals in duplicate to Engineer. Updated progress schedules and submittal schedules shall be submitted with each partial pay request.
 - 2. Revise and resubmit as specified, and identify all changes made from previous schedule submittal.

B. Construction Schedule:

1. Within 10 days following approval of the Shop Drawings and after establishment of equipment delivery dates the Contractor shall provide a bar chart analysis of the required construction Work for the Project. All activities should be shown along with the required time to do the Work in a proper and continuous sequence of operation and without delays.
2. Show complete sequence of construction by activity, identifying Work of separate stages, and other logically grouped activities. Indicate dates for early and late start, early and late finish, float, and duration.
3. Any contingency within the schedule (i.e., a difference in time between the Project's early completion and required Contract completion date) and the float in the overall Project schedule will belong to the Project and not to the parties to the Contract. Contractor shall not sequester shared float through such strategies as extending duration estimates to consume available float time, extensive crew/resource sequencing, etc.
4. Provide a workable plan for monitoring the progress of all elements of the Work, establish the critical elements of Work, and forecast potential problems in maintaining the specified completion dates.

C. Schedule of Submittals:

1. Schedule of Submittals: Indicate submittals required by Specification section number with brief description, starting and completion dates for respective submittal preparation, and submittal review by Engineer.
2. Indicate product manufacture and delivery dates.

D. Plan the Work and carry it out with minimum interference to the operation of the existing facilities. Prior to starting the Work, confer with the Engineer and Owner's representative to develop an approved Work schedule which will permit the facilities to function normally as practical. It may be necessary to do certain parts of the construction Work outside normal working hours in order to avoid undesirable conditions. The Contractor shall do this Work at such times, and at no additional cost to the Owner. Do not make connections between existing Work and new Work until necessary inspection and tests have been completed on the new Work and it is found to conform in all respects to the requirements of the Contract Documents.

E. No Work shall be started until the Contractor has received approved shop Drawings, established material/delivery dates for all equipment, and received approval of the construction schedule from the Engineer. The Contractor shall have sufficient manpower, equipment, and material to complete the Project. No Work shall commence without express consent of the Engineer.

2.02 COORDINATION

- A. Contractors shall cooperate in the coordination of their separate activities in a manner that will provide the least interference with the Owner's operations and other contractors and utility companies working in the area, and in the interfacing and connection of the separate elements of the overall Project Work.
- B. If any difficulty or dispute should arise in the accomplishment of the above, the problem shall be brought immediately to the attention of the Engineer.
- C. All contractors working on the Site are subject to this requirement for cooperation and all shall abide by the Engineer's decision in resolving Project coordination problems without additional cost to the Owner.
- D. All roof area shall be made dry and waterproof prior to leaving the site.

PART 3 SITE CONDITIONS

3.01 SITE INVESTIGATION AND REPRESENTATION

- A. The Contractor acknowledges satisfaction as to the general nature and location of the Work, the general and local conditions, particularly those bearing upon availability of transportation, availability of labor, water, electric power, roads, and uncertainties of weather, river stages, or similar physical conditions, the character of equipment and facilities needed preliminary to and during the prosecution of the Work, and all other matters which can in any way affect the Work or the cost thereof under this Contract.
- B. Failure by the Contractor to become acquainted with the physical conditions and all the available information will not relieve the Contractor from responsibility for properly estimating the difficulty or cost of successfully performing the Work.
- C. The Contractor warrants that as a result of examination and investigation of all the aforesaid data, the Contractor can perform the Work in a good and workmanlike manner and to the satisfaction of the Owner. The Owner assumes no responsibility for any representations made by any of its officers or agents during or prior to the execution of this Contract, unless (1) such representations are expressly stated in the Contract, and (2) the Contract expressly provides that the responsibility therefore is assumed by the Owner.

3.02 INFORMATION ONSITE CONDITIONS

- A. General: Any information obtained by the Engineer regarding Site conditions, subsurface information, , existing construction of Site facilities as applicable, and similar data will be available for inspection at the office of the Engineer upon request. Such information is offered as supplementary information only. Neither the Engineer nor the Owner assumes any responsibility for the completeness or interpretation of such supplementary information.

3.03 CONTRACTOR'S RESPONSIBILITY FOR UTILITY PROPERTIES AND SERVICE

- A. Where the Contractor's operations could cause damage or inconvenience to utilities, telephone, television, power, water, or sewer systems, the operations shall be suspended until all arrangements necessary for the protection of these utilities and services have been made by the Contractor with the owner of the utility affected.
- B. Notify all utility offices which are affected by the construction operation at least 48 hours in advance. Under no circumstances expose any utility without first obtaining permission from the appropriate agency. Once permission has been granted, locate, expose, and provide temporary support for all existing underground utilities.
- C. The Contractor shall be solely and directly responsible to the Owner and operators of such properties for any damage, injury, expense, loss, inconvenience, delay, suits, actions, or claims of any character brought because of any injuries or damage which may result from the construction operations under this Contract.
- D. Neither the Owner nor its officers or agents shall be responsible to the Contractor for damages as a result of the Contractor's failure to protect utilities encountered in the Work.
- E. In the event of interruption to domestic water, sewer, storm drain, or other utility services as a result of accidental breakage due to construction operations, promptly notify the proper authority. Cooperate with said authority in restoration of service as promptly as possible and bear all costs of repair. In no case shall interruption of any water or utility service be allowed to exist outside working hours unless prior approval is granted.
- F. In the event the Contractor encounters water service lines that interfere with trenching, he may, by obtaining prior approval of the property owner, Florida Keys Aqueduct Authority, or Fire Department as applicable, and the Engineer, cut the service, dig through, and restore the service with similar and equal materials at the Contractor's expense.

- G. The Contractor shall replace, at his own expense, all existing utilities or structures removed or damaged during construction, unless otherwise provided for in these Contract documents or ordered by the Engineer.

3.04 INTERFERING STRUCTURES

- A. Take necessary precautions to prevent damage to existing structures whether on the surface, aboveground, or underground.
- B. Protect underground and aboveground existing structures from damage, whether or not they lie within the limits of the easements obtained by the Owner. Where such existing fences, gates, sheds, buildings, or any other structure must be removed in order to properly carry out the construction, or are damaged during construction, restore to their original condition to the satisfaction of the property owner involved at the Contractor's own expense. Notify the Engineer of any damaged underground structure, and make repairs or replacements before backfilling.

3.05 FIELD RELOCATION

- A. During the progress of construction, it is expected that minor relocations of the work will be necessary. Such relocations shall be made only by direction of the Engineer. If existing structures are encountered which prevent the construction, and which are not properly shown on any Contract Drawings, notify the Engineer before continuing with the construction in order that the Engineer may make such field revisions as necessary to avoid conflict with the existing structures. If the Contractor shall fail to so notify the Engineer when an existing structure is encountered, and shall proceed with the construction despite this interference, he shall do so at his own risk.

PART 4 TEMPORARY CONSTRUCTION UTILITIES AND FACILITIES

4.01 TEMPORARY WATER

- A. The Contractor shall make his own arrangements to obtain suitable water and shall pay all costs.

4.02 TEMPORARY ELECTRIC POWER

- A. The Contractor shall make arrangements to obtain and pay for electrical power used until final acceptance by the Owner.

4.03 SAFETY REQUIREMENTS FOR TEMPORARY ELECTRIC POWER

- A. Temporary electric power installation shall meet the construction safety requirements of OSHA, state and other governing agencies.

4.04 SANITARY FACILITIES

- A. The Contractor shall provide and maintain sanitary facilities for his employees and his subcontractors that will comply with the regulations of the local and state departments of health and as directed by the Engineer.

4.05 STORAGE OF MATERIALS

- A. Materials shall be stored based on manufacturer's instructions to ensure the preservation of their quality and fitness for the Work. When considered necessary they shall be placed on wooden platforms or other hard, clean surfaces, and not on the ground. Stored materials shall be located so as to facilitate prompt inspection. Private property shall not be used for storage purposes without the written permission of the Owner or lessee.
- B. Delicate instruments and materials subject to vandalism shall be placed under locked cover and, if necessary, provided with temperature control as recommended by the manufacturer.

PART 5 SALVAGE OF MATERIALS

5.01 MATERIAL TO BE SALVAGED

- A. Materials to be salvaged include: None.

PART 6 SAFETY AND CONVENIENCE

6.01 SAFETY EQUIPMENT

- A. The Contractor shall do all Work necessary to protect the general public from hazards, including, but not limited to, surface irregularities or unramped grade changes in pedestrian sidewalk or walkway, and trenches or excavations in roadway. Barricades, lanterns, and proper signs shall be furnished in sufficient amount to safeguard the public and the Work. All barricades and signs shall be clean and serviceable, in the opinion of the Engineer.
- B. During construction, the Contractor shall construct and at all times maintain satisfactory and substantial temporary chain link fencing, solid fencing, railing, barricades or steel plates, as applicable, at all openings, obstructions, or other hazards in streets, sidewalks, floors, roofs, and walkways. All such barriers shall have adequate warning lights as necessary, or required, for safety. All lights shall be regularly maintained, and in a fully operational state at all times.

6.02 ACCIDENT REPORTS

- A. In addition, the Contractor must promptly report in writing to the Engineer all accidents whatsoever arising out of, or in connection with, the performance of the Work whether on, or adjacent to, the Site, giving full details and statements of witnesses. If death or serious injuries or serious damages are caused, the accident shall be reported immediately by telephone or messenger to the Engineer.
- B. If a claim is made by anyone against the contractor or any subcontractor on account of any accident, the Contractor shall promptly report the facts in writing to the Engineer, giving full details of the claim.

6.03 SAFE ACCESS BY FEDERAL, STATE, AND LOCAL GOVERNMENT OFFICIALS

- A. Authorized representatives of the state, federal, or local governmental agencies, shall at all times have safe access to the Work, and the Contractor shall provide proper facilities for such access and inspection.

6.04 PROTECTION OF PROPERTY

- A. Protect stored materials located adjacent to the proposed Work. Notify property owners affected by the construction at least 48 hours in advance of the time construction begins. During construction operations, construct and maintain such facilities as may be required to provide access by all property owners to their property. No person shall be cut off from access to his residence or place of business for a period exceeding 8 hours, unless the Contractor has made special arrangements with the affected persons.
- B. The Contractor shall identify and isolate his Work zone in such a manner as to exclude all personnel not employed by him, the Engineer, and the Owner.

6.05 FIRE PREVENTION AND PROTECTION

- A. The Contractor shall perform all Work in a fire-safe manner. He shall supply and maintain on the Site adequate fire-fighting equipment capable of extinguishing incipient fires. The Contractor shall comply with applicable federal, state, and local fire-prevention regulations. Where these regulations do not apply, applicable parts of the National Fire Prevention Standard for Safeguarding Building Construction Operations (NFPA No. 241) shall be followed.

6.06 CLEANUP PROCEDURES FOR HURRICANE WARNINGS AND HURRICANE WATCHES

- A. In the event that the National Oceanographic and Atmospheric Administration (NOAA), issues a hurricane watch for the Florida Keys, the Engineer will contact the Contractor informing him that the watch has been established within 4 hours of the notice. The Contractor shall implement the approved plan and schedule describing how and when the Contractor will remove all unnecessary items from the Work area and tie down all remaining supplies and barricades in the event that a hurricane warning is issued. If a warning is issued, the Contractor shall remove all unnecessary items from the Work area(s) and shall tie down all movable (under 200 pounds) objects. The Engineer will determine “necessary” items. The Owner will not be liable for any financial hardship or delays caused as a result of demobilization or remobilization due to the above.

PART 7 PRESERVATION, RESTORATION, AND CLEANUP

7.01 SITE RESTORATION AND CLEANUP

- A. At all times during the Work, keep the premises clean, dry, and orderly, and upon completion of the Work, repair all damage caused by equipment and leave the Project free of rubbish or excess materials of any kind.
- B. Stockpile excavated materials in a manner that will cause the least damage to adjacent lawns, grassed areas, gardens, shrubbery, or fences, regardless of whether these are on private property, or on state, county, or city rights-of-way. Remove all excavated materials from grassed and planted areas, and leave these surfaces in a condition equivalent to their original condition.

7.02 FINISHING OF SITE, AND STORAGE AREAS

- A. Upon completion of the Project, all areas used by the Contractor shall be properly cleared of all temporary structures, rubbish, and waste materials and properly graded to drain and blend in with the abutting property. Areas used for the deposit of waste materials shall be finished to properly drain and blend with the surrounding terrain.

7.03 DUST PREVENTION

- A. Give all unpaved streets, roads, detours, haul roads or disturbed areas used in the construction area an approved dust-preventive treatment or periodically water to prevent dust. Applicable environmental regulations for dust prevention shall be strictly enforced.

PART 8 SUBMITTALS DURING CONSTRUCTION**8.01 RECORD DRAWINGS**

- A. The Contractor shall maintain a complete set of record Drawings to show any items which differ from those shown on Drawings. Such Drawings shall be updated daily and submitted each month with the partial pay request. Final record Drawings will be required before substantial completion can be certified and final payment can be made.
- B. The Contractor shall keep the Engineer apprised on a weekly basis, by providing Drawing mark-ups of the items that differ.

PART 9 PRE- AND POST-CONSTRUCTION VIDEO RECORDINGS**9.01 GENERAL**

- A. The Contractor shall provide color videos showing the pre-construction Site, and the post-construction Site. The videos shall be in digital (DVD) format, the video shall indicate on the DVD the date, job title, and brief description of the video and location where the video was taken. Video shall be subject to review and approval by Engineer. Two copies of the video DVD (including the original) shall be delivered to the Engineer as follows:
 - 1. A video shall be taken of the preconstruction conditions, as well as all storage and staging areas, and the property adjacent to the construction Sites. Particular emphasis should be directed to roadway conditions as well as all right-of-way features that will be affected by the construction.
 - 2. A video shall be taken of the post-construction conditions and their adjacent properties. Particular emphasis should be directed to roadway conditions as well as all right-of-way features that were affected by the construction.
- B. The Following shall be Included with the Video Documentation:
 - 1. Coverage is required within and adjacent to the right-of-way, and easements, and storage, and staging areas where the Work is being constructed.
 - 2. Documentation of the conditions of the adjacent properties or any affected structures as a result of the impending construction.
 - 3. Certification as to date Work done and by whom.
 - 4. All videos shall be keyed to the construction Drawings.

- C. Pre-Construction and Post-Construction on Videos shall be Submitted as Follows:
1. Pre-construction videos shall be presented to the Owner at the pre-construction conference.
 2. Post-construction videos shall be submitted prior to final Project closeout. This submittal is contingent to final payment.

END OF SECTION

**SECTION 01 11 00
SUMMARY OF WORK**

PART 1 GENERAL

1.01 WORK COVERED BY CONTRACT DOCUMENTS

- A. The completed Work will provide Owner with new roof assemblies to the Administration Building and as an alternate, the Chlorine Building, at the Richard A. Heyman Environmental Protection Facility. Work will include repair of existing parapets and installation of new roof curbs, guy wires and metal coping system, walk pads, flashing, and other roof appurtenances. Design will include a lightening protection system.

- B. Work will include, but is not limited to, demolition of existing roof systems down to concrete roof deck, examination of roof substrate and repair if required, and disposing of all demolition and construction debris.

PART 2 PRODUCTS (NOT USED)

PART 3 EXECUTION (NOT USED)

END OF SECTION

SECTION 01 29 00
PAYMENT PROCEDURES

PART 1 GENERAL

1.01 SUBMITTALS

- A. Informational Submittals:
 - 1. Schedule of Values: Submit on Contractor's standard form.
 - 2. Schedule of Estimated Progress Payments:
 - a. Submit with initially acceptable Schedule of Values.
 - b. Submit adjustments thereto with Application for Payment.
 - 3. Application for Payment.
 - 4. Final Application for Payment.

1.02 ALLOWANCES

- A. Consult with Engineer in selection of products or services. Obtain proposals from suppliers and offer recommendations.
- B. Allowances will be administered in accordance with Paragraph 11.02 of General Conditions.
- C. Submit, with application for payment, invoice showing date of purchase, from whom the purchase was made, the date of delivery of the product or service, and the price, including delivery to the Site and applicable taxes.

1.03 SCHEDULE OF VALUES

- A. Prepare a separate Schedule of Values for each schedule of the Work under the Agreement.
- B. Upon request of Engineer, provide documentation to support the accuracy of the Schedule of Values.
- C. Lump Sum Work:
 - 1. Reflect specified contingency allowances and alternates, as applicable.
 - 2. List bonds and insurance premiums, mobilization, demobilization, preliminary and detailed progress schedule preparation, equipment testing, facility startup, and contract closeout separately.

- D. An unbalanced or front-end loaded schedule will not be acceptable.
- E. Summation of the complete Schedule of Values representing all the Work shall equal the Contract Price.

1.04 SCHEDULE OF ESTIMATED PROGRESS PAYMENTS

- A. Show estimated payment requests throughout Contract Times aggregating initial Contract Price.
- B. Base estimated progress payments on initially acceptable progress schedule. Adjust to reflect subsequent adjustments in progress schedule and Contract Price as reflected by modifications to the Contract Documents.

1.05 APPLICATION FOR PAYMENT

- A. Transmittal Summary Form: Attach one Summary Form with each detailed Application for Payment for each schedule and include Request for Payment of Materials and Equipment on Hand as applicable. Execute certification by authorized officer of Contractor.
- B. Use detailed Application for Payment Form provided by Owner.
- C. Provide separate form for each schedule as applicable.
- D. Include accepted Schedule of Values for each schedule or portion of lump sum Work and the unit price breakdown for the Work to be paid on a unit priced basis.
- E. Include separate line item for each Change Order and Work Change Directive executed prior to date of submission. Provide further breakdown of such as requested by Engineer.
- F. Preparation:
 - 1. Round values to nearest dollar.
 - 2. Submit Application for Payment, including a Transmittal Summary Form and detailed Application for Payment Form(s) for each schedule as applicable, a listing of materials on hand for each schedule as applicable, and such supporting data as may be requested by Engineer.

1.06 PAYMENT

- A. Payment for all Lump Sum Work shown or specified in Contract Documents is included in the Contract Price. Payment will be based on a percentage complete basis for each line item of the accepted Schedule of Values.

1.07 NONPAYMENT FOR REJECTED OR UNUSED PRODUCTS**A. Payment will not be made for following:**

1. Loading, hauling, and disposing of rejected material.
2. Quantities of material wasted or disposed of in manner not called for under Contract Documents.
3. Rejected loads of material, including material rejected after it has been placed by reason of failure of Contractor to conform to provisions of Contract Documents.
4. Material not unloaded from transporting vehicle.
5. Defective Work not accepted by Owner.
6. Material remaining on hand after completion of Work.

1.08 PARTIAL PAYMENT FOR STORED MATERIALS AND EQUIPMENT

- A. **Partial Payment:** No partial payments will be made for materials and equipment delivered or stored unless Shop Drawings and preliminary operation and maintenance data is acceptable to Engineer.
- B. **Final Payment:** Will be made only for products incorporated in Work; remaining products, for which partial payments have been made, shall revert to Contractor unless otherwise agreed, and partial payments made for those items will be deducted from final payment.

PART 2 PRODUCTS (NOT USED)**PART 3 EXECUTION (NOT USED)****END OF SECTION**

SECTION 01 31 19
PROJECT MEETINGS

PART 1 GENERAL

1.01 GENERAL

- A. Engineer will schedule physical arrangements for meetings throughout progress of Work, prepare meeting agenda with regular participant input and distribute with written notice of each meeting, preside at meetings, record minutes to include significant proceedings and decisions, and reproduce and distribute copies of minutes within 5 days after each meeting to participants and parties affected by meeting decisions.

1.02 PRECONSTRUCTION CONFERENCE

- A. Contractor shall be prepared to discuss the following subjects, as a minimum:

1. Required schedules (Preliminary Construction Schedule, Schedule of Values, Submittal).
2. Status of Bonds and insurance.
3. Sequencing of critical path work items.
4. Progress payment procedures.
5. Project changes and clarification procedures.
6. Use of Site, access, office and storage areas, security and temporary facilities.
7. Major product delivery and priorities.
8. Contractor's safety plan and representative.
9. Preliminary Hurricane Evaluation Plan.

- B. Attendees will Include:

1. Owner's representatives.
2. Contractor's office representative.
3. Contractor's resident superintendent.
4. Contractor's quality control representative.
5. Subcontractors' representatives whom Contractor may desire or Engineer may request to attend.
6. Engineer's representatives.
7. Others as appropriate.

1.03 PROGRESS MEETINGS

- A. Engineer will schedule regular progress meetings at Site, conducted monthly to review Work progress, progress schedule, Shop Drawing and Sample submissions schedule, Application for Payment, contract modifications, and other matters needing discussion and resolution.
- B. Attendees will Include:
 - 1. Owner's representative(s), as appropriate.
 - 2. Contractor, Subcontractors, and Suppliers, as appropriate.
 - 3. Engineer's representative(s).
 - 4. Others as appropriate.

1.04 QUALITY CONTROL AND COORDINATION MEETINGS

- A. Scheduled by Engineer on regular basis and as necessary to review test and inspection reports, and other matters relating to quality control of Work and work of other contractors.
- B. Attendees will Include:
 - 1. Contractor.
 - 2. Contractor's designated quality control representative.
 - 3. Subcontractors and Suppliers, as necessary.
 - 4. Engineer's representatives.

1.05 PREINSTALLATION MEETINGS

- A. When required in individual Specification sections, convene at Site prior to commencing Work of that section.
- B. Require attendance of entities directly affecting, or affected by, Work of that Section.
- C. Notify Engineer 4 days in advance of meeting date.
- D. Provide suggested agenda to Engineer to include reviewing conditions of installation, preparation and installation or application procedures, and coordination with related Work and work of others.

1.06 OTHER MEETINGS

- A. In accordance with Contract Documents and as may be required by Owner and Engineer.

PART 2 PRODUCTS (NOT USED)

PART 3 EXECUTION (NOT USED)

END OF SECTION

SECTION 01 32 00
PROGRESS SCHEDULES

PART 1 GENERAL

1.01 SUBMITTALS

- A. Preliminary Progress Schedule: Submit within time specified in paragraph 2.05 of the General Conditions.
- B. Detailed Progress Schedule: Submit initial Detailed Progress Schedule within 30 days after Effective Date of the Agreement.
- C. Submit with Each Progress Schedule Submission:
 - 1. Contractor's certification that progress schedule submission is the actual schedule being utilized for execution of the Work.
 - 2. Progress Schedule: Four legible copies.
 - 3. Narrative Progress Report: Same number of copies as specified for Progress Schedule.
- D. Prior to final payment, submit a final Updated Progress Schedule.

1.02 PRELIMINARY PROGRESS SCHEDULE

- A. In addition to basic requirements outlined in General Conditions, show a detailed schedule, beginning with Notice to Proceed, for minimum duration of 120 days, and a summary of balance of Project through Final Completion.
- B. Show activities including, but not limited to the following:
 - 1. Notice to Proceed.
 - 2. Permits.
 - 3. Submittals, with review time.
 - 4. Early procurement activities for long lead equipment and materials.
 - 5. Initial site work.
 - 6. Earthwork.
 - 7. Specified Work sequences and construction constraints.
 - 8. Contract Milestone and Completion Dates.
 - 9. Owner-furnished products delivery dates or ranges of dates.
 - 10. Major structural, mechanical, equipment, electrical, architectural, and instrumentation and control Work.
 - 11. System startup summary.
 - 12. Project close-out summary.
 - 13. Demobilization summary.

- C. Update Preliminary Progress Schedule monthly; as part of progress payment process. Failure to do so may cause Owner to withhold all or part of the monthly progress payment until the Preliminary Progress Schedule is updated in a manner acceptable to Engineer.
- D. Format: In accordance with Article Progress Schedule - Bar Chart.
- E. Detailed progress schedule.
- F. In addition to requirements of General Conditions, submit Detailed Progress Schedule beginning with Notice to Proceed and continuing through Final Completion.
- G. Show the duration and sequences of activities required for complete performance of the Work reflecting means and methods chosen by Contractor.
- H. When accepted by Engineer, Detailed Progress Schedule will replace Preliminary Progress Schedule and become Baseline Schedule. Subsequent revisions will be considered as Updated Progress Schedules.
- I. Update monthly to reflect actual progress and occurrences to date, including weather delays.

1.03 PROGRESS SCHEDULE - BAR CHART

- A. General: Comprehensive bar chart schedule, generally as outlined in Associated General Contractors of America (AGC) Publication No. 1107.1, "Construction Planning and Scheduling, latest edition. If a conflict occurs between the AGC publication and this specification, this specification shall govern.
- B. Format:
 - 1. Unless otherwise approved, white paper, 11-inch by 17-inch sheet size.
 - 2. Title Block: Show name of project and Owner, date submitted, revision or update number, and name of scheduler.
 - 3. Identify horizontally, across the top of the schedule, the time frame by year, month, and day.
 - 4. Identify each activity with a unique number and a brief description of the Work associated with that activity.
 - 5. Legend: Describe standard and special symbols used.
- C. Contents: Identify, in chronological order, those activities reasonably required to complete the Work, including as applicable, but not limited to:
 - 1. Obtaining permits, submittals for early product procurement and long lead time items.

2. Mobilization and other preliminary activities.
3. Initial Site Work.
4. Specified Work sequences, constraints, and Milestones, including Substantial Completion date(s) Subcontract Work.
5. Major equipment design, fabrication, factory testing, and delivery dates.
6. Site Work.
7. Concrete Work.
8. Electrical Work.
9. Project closeout and cleanup.
10. Demobilization.

1.04 PROGRESS OF THE WORK

- A. Updated Progress Schedule shall reflect:
 1. Progress of Work to within 5 working days prior to submission.
 2. Approved changes in Work scope and activities modified since submission.
 3. Delays in Submittals or resubmittals, deliveries, or Work.
 4. Adjusted or modified sequences of Work.
 5. Other identifiable changes.
 6. Revised projections of progress and completion.
 7. Report of changed logic.
- B. Produce detailed subschedules during Project, upon request of Owner or Engineer, to further define critical portions of the Work such as facility shutdowns, etc.
- C. If Contractor fails to complete activity by its latest scheduled completion date and this failure is anticipated to extend Contract Times (or Milestones), Contractor shall, within 7 days of such failure, submit a written statement as to how Contractor intends to correct nonperformance and return to acceptable current progress schedule. Actions by Contractor to complete Work within Contract Times (or Milestones) will not be justification for adjustment to Contract Price or Contract Times.
- D. Owner may order Contractor to increase plant, equipment, labor force or working hours if Contractor fails to:
 1. Complete a Milestone activity by its completion date.
 2. Satisfactorily execute Work as necessary to prevent delay to overall completion of Project, at no additional cost to Owner.

1.05 NARRATIVE PROGRESS REPORT

A. Format:

1. Organize same as Progress Schedule.
2. Identify, on a cover letter, reporting period, date submitted, and name of author of report.

B. Contents:

1. Number of days worked over the period, work force on hand, construction equipment on hand (including utility vehicles such as pickup trucks, maintenance vehicles, stake trucks, etc.).
2. General progress of Work, including a listing of activities started and completed over the reporting period, mobilization/demobilization of subcontractors, and major milestones achieved.
3. Contractor's plan for management of site (e.g., lay down and staging areas, construction traffic, etc.), utilization of construction equipment, buildup of trade labor, and identification of potential Contract changes.
4. Identification of new activities and sequences as a result of executed Contract changes.
5. Documentation of weather conditions over the reporting period, and any resulting impacts to the work.
6. Description of actual or potential delays, including related causes, and the steps taken or anticipated to mitigate their impact.
7. Changes to activity logic.
8. Changes to the critical path.
9. Identification of, and accompanying reason for, any activities added or deleted since the last report.
10. Steps taken to recover the schedule from Contractor-caused delays.

1.06 SCHEDULE ACCEPTANCE

A. Engineer's acceptance will demonstrate agreement that the proposed schedule conforms with requirements of Contract including, but not limited to, the following:

1. Contract Times, including Final Completion and all intermediate Milestones are within the specified times.
2. Specified Work sequences and constraints are shown as specified.
3. Complete Scope of Work is included.
4. Access restrictions are accurately reflected.
5. Level of detail is as specified herein.
6. Submittal submission and review times are as specified.
7. Duration of activities are reasonable.
8. Sequencing is reasonable and does not include preferential logic contrary to the contingency/float sharing clauses of this Specification.

9. Meets all administrative requirements of Contract Documents.
10. Updated schedules reflect actual dates and duration of Work performed.

B. Preliminary Progress Schedule Review Disposition:

1. Accepted.
2. Rejected as Noted:
 - a. Make requested corrections; resubmit within 10 days.
 - b. Until acceptable to Engineer as the Baseline Progress Schedule, continue the review and revision process, during which time Contractor shall update the schedule on a monthly basis to reflect actual progress and occurrences to date.

C. Detailed Progress Schedule:

1. Accepted.
2. Rejected as Noted:
 - a. Make requested corrections; resubmit within 10 days.
 - b. Until acceptable to Engineer as the Baseline Progress Schedule, continue the review and revision process.

D. Narrative Report: All changes to activity duration and sequences, including the addition or deletion of activities subsequent to Engineer's acceptance of the Baseline Progress Schedule, shall be delineated in the Narrative Report current with the proposed Updated Progress Schedule.

1.07 ADJUSTMENT OF CONTRACT TIMES

A. Reference General Conditions.

B. Evaluation and reconciliation of Adjustments of Contract Times shall be based on the Updated Progress Schedule at the time of proposed adjustment or claimed delay.

C. Schedule Contingency:

1. Contingency, when used in the context of the Progress Schedule, is time between Contractor's proposed Completion Time and Contract Completion Time.
2. Contingency included in Progress Schedule is a Project resource available to both Contractor and Owner to meet Contract Milestones and Contract Times. Use of Schedule contingency shall be shared to the proportionate benefit of both parties.
3. Use of schedule contingency suppression techniques such as preferential sequencing and extended activity times are prohibited.

4. Pursuant to Contingency sharing provisions of this Specification, no time extensions will be granted, nor will delay damages be paid until a delay occurs which (i) consumes all available contingency time, and (ii) extends Work beyond the Contract Completion date.

D. Claims Based on Contract Times:

1. Where Engineer has not yet rendered formal decision on Contractor's claim for adjustment of Contract Times, and parties are unable to agree as to amount of adjustment to be reflected in progress schedule, Contractor shall reflect an interim adjustment in the progress schedule as acceptable to Engineer.
2. It is understood and agreed that such interim acceptance will not be binding on either Contractor or Owner, and will be made only for the purpose of continuing to Schedule Work until such time as formal decision has been rendered as to an adjustment, if any, of the Contract Times.
3. Contractor shall revise Progress Schedule prepared thereafter in accordance with Engineer's formal decision.

PART 2 PRODUCTS (NOT USED)

PART 3 EXECUTION (NOT USED)

END OF SECTION

SECTION 01 33 00
SUBMITTALS

PART 1 GENERAL

1.01 GENERAL

- A. Inquiries: Direct to Engineer regarding procedure, purpose, or extent of Submittal.
- B. Timeliness: Schedule and make submissions in accordance with requirements of individual Specification sections and in such sequence as to cause no delay in Work or in Work of other contractors.
- C. Identification of Submittals:
 - 1. Complete, sign, and transmit with each Submittal package, one Transmittal of Contractor's Submittal Form attached at end of this Section.
 - 2. Identify each Submittal with the following numbering and tracking system:
 - a. Sequentially number each Submittal.
 - b. Resubmission of a Submittal will have original number with sequential alphabetic suffix.
 - 3. Format: Orderly, indexed with labeled tab dividers.
 - 4. Show date of submission.
 - 5. Show Project title and Owner's contract identification and contract number.
 - 6. Show names of Contractor, Subcontractor or Supplier, and manufacturer as appropriate.
 - 7. Identify, as applicable, Contract Document section and paragraph to which Submittal applies.
 - 8. Identify Submittal type; submit only one type in each Submittal package.
 - 9. Identify and indicate each deviation or variation from Contract Documents.
- D. Resubmissions: Clearly identify each correction or change made.
- E. Incomplete Submittal Submissions:
 - 1. Engineer will return entire Submittal for Contractor's revision/correction and resubmission.
 - 2. Submittals which do not clearly bear Contractor's specific written indication of Contractor review and approval of Submittal or which are transmitted with an unsigned or uncertified submission form or as may otherwise be required will be returned to Contractor unreviewed.

- F. Nonspecified Submissions: Submissions not required under these Contract Documents and not shown on submissions will not be reviewed and will be returned to Contractor.
- G. Engineer's Review: Engineer will act upon Contractor's Submittal and transmit response to Contractor not later than 20 working days after receipt, unless otherwise specified. Resubmittals will be subject to same review time.
- H. Schedule Delays:
 - 1. No adjustment of Contract Times or Price will be allowed due to Engineer's review of Submittals, unless all of the following criteria are met:
 - a. Contractor has notified Engineer in writing that timely review of Submittal in question is critical to progress of Work, and has received Engineer's written acceptance to reflect such on current accepted submissions and progress schedule. Written agreement by the Engineer to reduce Submittal review time will be made only for unusual and Contractor-justified reasons. Acceptance of a progress schedule containing Submittal review times less than specified or less than agreed to in writing by Engineer will not constitute Engineer's acceptance of review times.
 - b. Engineer has failed to review and return first submission of a Submittal within agreed time indicated on current accepted schedule of submissions or, if no time is indicated thereon, within 30 days after receipt.
 - c. Contractor demonstrates that delay in progress of Work is directly attributable to Engineer's failure to return Submittal within time indicated and accepted by Engineer.
 - 2. No adjustment of Contract Times or Price will be allowed due to delays in progress of Work caused by rejection and subsequent resubmission of Submittals, including multiple resubmissions.

1.02 SHOP DRAWINGS AND SAMPLES

- A. Copies:
 - 1. Shop Drawings and Product Data: Submit four copies, plus whatever the Contractor requires to be returned, maximum eight.
 - 2. Samples: Two, unless otherwise specified in individual Specification sections.

3. Electronic Submittals: Contractor may be required to submit all documents electronically. If so the following will be followed:
 - a. Each submittal shall be an electronic file in Adobe Acrobat Portable Document Format (PDF). Use the latest version available at the time of execution of the Contract Documents. Electronic files which contain more than ten (10) pages in Adobe Acrobat format shall contain internal book-marking from an index page to major sections of the document. PDF files shall be set to open "Bookmarks and Page" view. General information shall be added to each PDF file, including Title, Subject, Author, and Keywords.
 - b. The PDF files shall be set up to print legibly at either 8-1/2-inch by 11-inch, 11-inch by 17-inch or 22-inch by 34-inch.
 - c. New electronic files shall be required for each submittal.
 - d. Each electronic file shall also include a copy of the Submittal Transmittal Form and completed Submittal Checklist.
 - e. Submittals shall be transmitted by uploading the PDF file of the submittal to the project SharePoint site. Submittal review comments will be transmitted back to the Subcontractor electronically via the project SharePoint site as well.
 - f. Subcontractor shall provide authorization to reproduce and/or distribute each file as many times as necessary for the Project.
 - g. Subcontractor shall include all costs for preparation and transmittal of electronic submittals in its bid, including all resubmittals and final record copies.
 - h. Final Record Copies: After all initial and resubmittal information has been approved, consolidate all information and responses to comments into one conformed record copy. Provide one electronic copy of the conformed record copy to CH2M HILL to verify incorporation of previously submitted data. Hard copies, number as required herein, that exactly match the final conformed electronic copy of the submittal will be submitted to CH2M HILL within 30 days of approval of the electronic copy.

- B. General: Submit to Engineer as required by individual Specification sections.

- C. Identify and Indicate:
 1. Pertinent Drawing sheet(s) and detail number(s), products, units and assemblies, and system or equipment identification or tag numbers.
 2. Critical field dimensions and relationships to other critical features of Work.
 3. Samples: Source, location, date taken, and by whom.
 4. Each deviation or variation from Contract Documents.
 5. Proper storage and maintenance requirements.

- D. Design Data: When specified, provide Project-specific information as required and as necessary to clearly show calculations, dimensions, logic and assumptions, and referenced standards and codes upon which design is based.
- E. Foreign Manufacturers: When proposed, include following additional information:
 - 1. Names and addresses of at least two companies closest to Project that maintain technical service representatives.
 - 2. Complete inventory of spare parts and accessories for each piece of equipment.
- F. Preparation:
 - 1. Format: Whenever possible, schedule for and combine Shop Drawings and Samples required for submission in each Specification section or division into a single Submittal package. Also combine product data for like items into a single Submittal package.
 - 2. Present in a clear and thorough manner and of sufficient detail to show kind, size, arrangement, and function of components, materials, and devices and compliance with Contract Documents. Identify details by reference to sheet and detail, and schedule or room numbers shown on Drawings.
 - 3. Reproducible Copy:
 - a. Preferred Minimum Sheet Size: 8-1/2- by 11-inch and 11- by 17-inch pages, suitable for photocopying.
 - b. Larger than 11- by 17-Inch Sheets: 22-inch by 34-inch preferred, Mylar or sepias suitable for copying in a blueprint machine.
 - 4. Piping Systems: Drawn to scale.
 - 5. Product Data: Clearly mark each copy to identify pertinent products or models and show performance characteristics and capacities, dimensions and clearances required, wiring or piping diagrams and controls, and external connections, anchorage, and supports required.
 - 6. Equipment and Component Titles: Identical to title shown on Drawings.
 - 7. Manufacturer's Standard Schematic Drawings and Diagrams as Follows:
 - a. Modify to delete information that is not applicable to Work.
 - b. Supplement standard information to provide information specifically applicable to Work.
- G. Shop Drawing Disposition: Engineer will review, mark, and stamp as appropriate and distribute marked-up copies as noted:
 - 1. Approved as Submitted (for Incorporation in Work):
 - a. Two copies furnished Owner.
 - b. One copy furnished Resident Project Representative.
 - c. One copy retained in Engineer's file.

- d. Remaining copies returned to Contractor appropriately annotated.
 - e. Contractor may begin to implement activities to incorporate specific product(s) or Work covered by Submittal.
2. Approved as Noted (for Incorporation in Work):
- a. Two copies furnished Owner.
 - b. One copy furnished Resident Project Representative.
 - c. One copy retained in Engineer's file.
 - d. Remaining copies returned to Contractor appropriately annotated.
 - e. Contractor may begin to implement activities to incorporate product(s) or Work covered by Submittal, in accordance with Engineer's notations.
3. Disapproved:
- a. One copy furnished Resident Project Representative.
 - b. One copy retained in Engineer's file.
 - c. Remaining copies returned to Contractor appropriately annotated.
 - d. Contractor shall make corrections or develop replacement and resubmit (in same manner and quantity as specified for original submission).
 - e. Submittal is not approved.
4. Incomplete:
- a. One copy furnished Resident Project Representative.
 - b. One copy retained in Engineer's file.
 - c. Remaining copies returned to Contractor appropriately annotated.
 - d. Contractor shall complete and resubmit or submit missing portions.
 - e. Submittal is not approved.

H. Sample Disposition: Same as Shop Drawing disposition; samples will not be returned.

1.03 ADMINISTRATIVE SUBMITTALS

- A. Copies: Submit four.
- B. Description: Submittals that are not Shop Drawings or Samples, or that do not reflect quality of product or method of construction. May include, but not limited to those Submittals identified below.
- C. Applications for Payment (and Cash Allowance Data and Values): Meet requirements of Section 01 29 00, Payment Procedures.
- D. Progress Reports and Quantity Charts: As may be required in Section 01 32 00, Progress Schedules.

- E. Hurricane Evaluation Plan: The Contractor shall prepare the Engineer with a written plan and schedule describing how and when the Contractor will remove all unnecessary items from the work area and tie down all remaining supplies and barricades in the event that a hurricane warning is issued, identifying gussets in particular. If a warning is issued, the Contractor shall remove all unnecessary items from the work area(s) and will tie down all movable (under 200 pounds) objects. The Owner shall not be liable for any financial hardship or delays caused as a result of demobilization or remobilization due to the above.

- F. Schedules:
 - 1. Progress Schedule(s): Meet the requirements of Section 01 32 00, Progress Schedules.
 - 2. Schedule of Values: Meet requirements of Section 01 29 00, Payment Procedures.
 - 3. Schedule of Submittal Submissions:
 - a. Prepare and submit, preliminary list of submissions grouped by Contract Document article/paragraph number or Specification section number, with identification, numbering and tracking system as specified under Paragraph Identification of Submittals and as approved by Engineer.
 - b. Include Only the Following Required Submissions:
 - 1) Shop Drawings and Samples.
 - 2) Training plans.
 - 3) Test procedures.
 - 4) Operation and maintenance manuals.
 - 5) Record documents.
 - 6) Specifically required certificates, warranties, and service agreements.
 - c. Coordinate with progress schedule and prepare submissions to show for each Submittal, at a minimum, the following:
 - 1) Estimated submission date to Engineer.
 - 2) Specifically requested and clearly identified Engineer review time if shorter than that set forth herein, with justification for such request and critical dates Submittals will be needed from Engineer.
 - 3) For first 6-month period from the date the Contract Times commence or following any update or adjustment of the submissions, the estimated submission date shall be week, month, and year; for submissions beyond 6-month time period, show closest month and year.
 - d. Submit to Engineer Monthly:
 - 1) Updated list if changes have occurred. Otherwise, submit a written communication confirming existing list.

- 2) Adjusted submissions reflecting submission activity planned for forthcoming 6-month time period and beyond.
Coordinate with progress schedule updates.

G. Submittals Required by Laws, Regulations, and Governing Agencies:

1. Submit promptly notifications, reports, certifications, payrolls, and otherwise as may be required, directly to the applicable federal, state, or local governing agency or their representative.
2. Transmit to Engineer for Owner's records one copy of correspondence and transmittals (to include enclosures and attachments) between Contractor and governing agency.

H. Disposition: Engineer will review, stamp, and indicate requirements for resubmission or acceptance on Submittal as follows:

1. Accepted:
 - a. Acceptance will indicate that Submittal conforms to intent of Contract Documents as to form and substance.
 - b. Contractor may proceed to perform Submittal related Work.
 - c. One copy furnished Owner.
 - d. One copy furnished Resident Project Representative.
 - e. One copy retained in Engineer's file.
 - f. Remaining copies returned to Contractor appropriately annotated.
2. Rejected as Noted:
 - a. One copy retained in Engineer's file.
 - b. Remaining copies returned to Contractor appropriately annotated.
 - c. Contractor shall revise/correct or develop replacement and resubmit.

1.04 QUALITY CONTROL SUBMITTALS

- A. Certificates: Certificates of Successful Testing or Inspection: Submit when testing or inspection is required by Laws and Regulations or governing agency or specified in the individual Specification sections.
- B. Statements of Qualification: Evidence of qualification, certification, or registration. As required in these Contract Documents to verify qualifications of professional land surveyors, engineers, materials testing laboratories, specialty Subcontractors, trades, specialists, consultants, installers, and other professionals. Reference Article 1.01.A.51 of Supplementary Conditions for the definition of Specialist.
- C. Field Samples: Provide as required by individual Specifications and as may be required by Engineer during progress of Work.

- D. Written Test Reports of Each Test and Inspection: As a minimum, include the following:
1. Date of test and date issued, Project title and number, testing laboratory name, address, and telephone number, and name and signature of laboratory inspector.
 2. Date and time of sampling or inspection and record of temperature and weather conditions.
 3. Identification of product and Specification section, location of Sample, test or inspection in the Project, type of inspection or test with referenced standard or code, certified results of test.
 4. Compliance with Contract Documents, and identifying corrective action necessary to bring materials and equipment into compliance.
 5. Provide an interpretation of test results, when requested by Engineer.
- E. Disposition: Engineer will review, stamp, and indicate requirements for resubmission or acceptance on Submittal as follows:
1. Accepted:
 - a. Acceptance will indicate that Submittal conforms to intent of Contract Documents as to form and substance.
 - b. Contractor may proceed to perform Submittal related Work.
 - c. One copy furnished Owner.
 - d. One copy furnished Resident Project Representative.
 - e. One copy retained in Engineer's file.
 - f. Remaining copies returned to Contractor appropriately annotated.
 2. Rejected as Noted:
 - a. One copy retained in Engineer's file.
 - b. Remaining copies returned to Contractor appropriately annotated.
 - c. Contractor shall revise/correct or develop replacement and resubmit.

1.05 CONTRACT CLOSEOUT SUBMITTALS

- A. General: In accordance with Section 01 77 00, Contract Closeout.
- B. Disposition: Engineer will review, stamp, and indicate requirements for resubmission or acceptance on Submittal as follows:
1. Accepted:
 - a. Acceptance will indicate that Submittal conforms to intent of Contract Documents as to form and substance.
 - b. Contractor may proceed to perform Submittal related Work.
 - c. One copy furnished Owner.
 - d. One copy furnished Resident Project Representative.
 - e. One copy retained in Engineer's file.

- f. Remaining copies returned to Contractor appropriately annotated.
- 2. Rejected as Noted:
 - a. One copy retained in Engineer's file.
 - b. Remaining copies returned to Contractor appropriately annotated.
 - c. Contractor shall revise/correct or develop replacement and resubmit.

1.06 SUPPLEMENTS

A. The supplement listed below, following “END OF SECTION,” is part of this Specification.

- 1. Transmittal of Contractor's Submittal.

PART 2 PRODUCTS (NOT USED)

PART 3 EXECUTION (NOT USED)

END OF SECTION

CH2M HILL

TRANSMITTAL OF CONTRACTOR'S SUBMITTAL
(ATTACH TO EACH SUBMITTAL)

DATE: _____

TO: _____

Submittal No.: _____
 New Submittal Resubmittal
Previous Submittal No.: _____
Project: _____
Project No.: _____
Specification Section No.: _____

FROM: _____
Contractor

(Cover only one section with each transmittal)
Schedule Date of Submittal: _____

SUBMITTAL TYPE: Shop Drawing Administrative Sample
 Quality Control Contract Closeout "Or-Equal"/Substitute

The following items are hereby submitted:

Number of Copies	Description of Item Submitted (Type, Size, Model Number, Etc.)	Spec. Para. No.	Drawing or Brochure Number	Contains Variation to Contract	
				No	Yes

Contractor hereby certifies that (i) Contractor has complied with the requirements of Contract Documents in preparation, review, and submission of designated Submittal and (ii) the Submittal is complete and in accordance with the Contract Documents and requirements of laws and regulations and governing agencies.

By: _____
Contractor (Authorized Signature)

SECTION 01 42 13
ABBREVIATIONS

PART 1 GENERAL

1.01 REFERENCE TO STANDARDS AND SPECIFICATIONS OF TECHNICAL SOCIETIES

- A. Reference to standards and specifications of technical societies and reporting and resolving discrepancies associated therewith shall be as provided in paragraph 3.02 of the General Conditions, and as may otherwise be required herein and in the individual Specification sections.
- B. Work specified by reference to the published standard or specification of a government agency, technical association, trade association, professional society or institute, testing agency, or other organization shall meet the requirements or surpass the minimum standards of quality for materials and workmanship established by the designated standard or specification.
- C. Where so specified, products or workmanship shall also meet or exceed the additional prescriptive or performance requirements included within the Contract Documents to establish a higher or more stringent standard of quality than that required by the referenced standard.
- D. Where two or more standards are specified to establish quality, the product and workmanship shall meet or exceed the requirements of the most stringent.
- E. Where both a standard and a brand name are specified for a product in the Contract Documents, the proprietary product named shall meet or exceed the requirements of the specified reference standard.
- F. Copies of Standards and Specifications of Technical Societies:
 - 1. Copies of applicable referenced standards have not been bound in these Contract Documents.
 - 2. Where copies of standards are needed by the Contractor, obtain a copy or copies directly from the publication source and maintain in an orderly manner at the site as Work site records, available to the Contractor's personnel, Subcontractors, Owner, and Engineer.

1.02 ABBREVIATIONS

A. Abbreviations for trade organizations and government agencies: Following is a list of construction industry organizations and government agencies to which references may be made in the Contract Documents, with abbreviations used.

1. AA Aluminum Association
2. AAMA American Architectural Manufacturers Association
3. ACI American Concrete Institute
4. AISC American Institute of Steel Construction
5. AISI American Iron and Steel Institute
6. ALS American Lumber Standards
7. AMA Acoustical Materials Association
8. ANSI American National Standards Institute
9. APWA American Public Works Association
10. ASA American Standards Association
11. ASCE American Society of Civil Engineers
12. ASNT American Society for Nondestructive Testing
13. ASME American Society of Mechanical Engineers
14. ASTM American Society for Testing and Materials
15. AWI Architectural Wood Work Institute
16. AWPA American Wood Preservers' Association
17. AWPB American Wood Preservers Bureau
18. AWPI American Wood Preservers' Institute
19. AWS American Welding Society
20. AWWA American Water Works Association
21. BHMA Builders Hardware Manufacturers' Association
22. CDA Copper Development Association
23. CGA Compressed Gas Association
24. CRSI Concrete Reinforcing Steel Institute
25. CS Commercial Standard
26. CSI Construction Specifications Institute
27. EJCDC Engineers Joint Contract Documents' Committee
28. ETL Engineering Test Laboratories
29. FCC Federal Communications Commission
30. FEMA Federal Emergency Management Agency
31. FM Factory Mutual
32. Fed. Spec. Federal Specifications
33. FS Federal Specification
34. ICBO International Conference of Building Officials
35. ICEA Insulated Cable Engineers' Association
36. IEEE Institute of Electrical and Electronics Engineers, Inc.

37.	IFI	Industrial Fasteners Institute
38.	ISO	Insurance Service Office
39.	NAAMM	National Association of Architectural Metal Manufacturers
40.	NACE	National Association of Corrosion Engineers
41.	NBHA	National Builders' Hardware Association
42.	NEC	National Electrical Code
43.	NECA	National Electrical Contractor's Association
44.	NEMA	National Electrical Manufacturers' Association
45.	NESC	National Electric Safety Code
46.	NLMA	National Lumber Manufacturers' Association
47.	NRCA	National Roofing Contractors Association
48.	NSPE	National Society of Professional Engineers
49.	OSHA	Occupational Safety and Health Act (both Federal and State)
50.	PS	Product Standards Section-U.S. Department of Commerce
51.	UBC	Uniform Building Code
52.	UFC	Uniform Fire Code
53.	UL	Underwriters Laboratories Inc.
54.	UMC	Uniform Mechanical Code
55.	US	U.S. Bureau of Standards
56.	USBR	U.S. Bureau of Reclamation

PART 2 PRODUCTS (NOT USED)

PART 3 EXECUTION (NOT USED)

END OF SECTION

SECTION 01 43 33
MANUFACTURERS' FIELD SERVICES

PART 1 GENERAL

1.01 DEFINITIONS

- A. Person-Day: One person for 8 hours within regular Contractor working hours.

1.02 SUBMITTALS

- A. Certificates:

1. The following certificates are to be submitted to the Engineer if required by any specific specification section:
 - a. Manufacturer's Certificate of Compliance.
 - b. Manufacturer's Certificate of Proper Installation.

1.03 QUALIFICATION OF MANUFACTURER'S REPRESENTATIVE

- A. Provide manufacturer's representative at Site to provide training on installation, inspection, and maintenance of roofing system.
- B. Manufacturer's representative to be present during the Pre-Roofing Conference when the Contractor is ready to install roof and substantial completion.
- C. Authorized representative of the manufacturer, factory trained, and experienced in product installation of respective roofing system. Additional qualifications may be specified elsewhere.
- D. Representative subject to acceptance by Owner. No substitute representatives will be allowed unless prior written approval by such has been given.

PART 2 PRODUCTS (NOT USED)

PART 3 EXECUTION

3.01 FULFILLMENT OF SPECIFIED MINIMUM SERVICES

- A. Furnish manufacturers' services when required by an individual specification section, to meet the requirements of this section.
- B. Where time is necessary in excess of that stated in the Specifications for manufacturers' services, or when a minimum time is not specified, the time required to perform the specified services shall be considered incidental.

- C. Schedule manufacturer' services to avoid conflict with other onsite testing or other manufacturers' onsite services.
- D. Determine, before scheduling services, that all conditions necessary to allow successful testing have been met.
- E. Only those days of service approved by Engineer will be credited to fulfill the specified minimum services.
- F. When specified in individual Specification sections, manufacturer's onsite services shall include:
 - 1. Assistance during product (system, subsystem, or component) installation to include observation, guidance, instruction of Contractor's assembly, erection, installation or application procedures.
 - 2. Inspection, checking, and adjustment as required for product (system, subsystem, or component) to function as warranted by manufacturer and necessary to furnish Manufacturer's Certificate of Proper Installation.
 - 3. Providing, on a daily basis, copies of all manufacturers' representatives' field notes and data to Owner.
 - 4. Revisiting the Site as required to correct problems and until installation and operation are acceptable to Engineer.
 - 5. Resolution of assembly or installation problems attributable to, or associated with, respective manufacturer's products and systems.
 - 6. Assistance during functional and performance testing, and facility startup and evaluation.
 - 7. Training of Owner's personnel in the operation and maintenance of respective product as required.
 - 8. Additional requirements may be specified elsewhere.

3.02 MANUFACTURER'S CERTIFICATE OF COMPLIANCE

- A. When so specified, a Manufacturer's Certificate of Compliance, a copy of which is attached to this section, shall be completed in full, signed by the entity supplying the product, material, or service, and submitted prior to shipment of product or material or the execution of the services.
- B. Engineer may permit use of certain materials or assemblies prior to sampling and testing if accompanied by accepted certification of compliance.
- C. Such form shall certify that the proposed product, material, or service complies with that specified. Attach supporting reference data, affidavits, and certifications as appropriate.
- D. May reflect recent or previous test results on material or product, if acceptable to Engineer.

3.03 MANUFACTURER'S CERTIFICATE OF PROPER INSTALLATION

- A. When so specified, a Manufacturer's Certificate of Proper Installation form, a copy of which is attached to this section, shall be completed and signed by the equipment manufacturer's representative.
- B. Such form shall certify that the signing party is a duly authorized representative of the manufacturer, is empowered by the manufacturer to inspect, approve, and operate their equipment and is authorized to make recommendations required to assure that the equipment is complete and operational.

3.04 SUPPLEMENTS

- A. The supplements listed below, following "End of Section," are part of this Specification.
 - 1. Forms:
 - a. Manufacturer's Certificate of Compliance.
 - b. Manufacturer's Certificate of Proper Installation.

END OF SECTION

MANUFACTURER'S CERTIFICATE OF COMPLIANCE

OWNER:

PRODUCT, MATERIAL, OR SERVICE
SUBMITTED:

PROJECT NAME:

PROJECT NO:

Comments: _____

I hereby certify that the above-referenced product, material, or service called for by the contract for the named project will be furnished in accordance with all applicable requirements. I further certify that the product, material, or service are of the quality specified and conform in all respects with the contract requirements, and are in the quantity shown.

Date of Execution: _____, 20__

Manufacturer: _____

Manufacturer's Authorized Representative (*print*): _____

(Authorized Signature)

MANUFACTURER’S CERTIFICATE OF PROPER INSTALLATION

OWNER _____ EQPT SERIAL NO: _____

EQPT TAG NO: _____ EQPT/SYSTEM: _____

PROJECT NO: _____ SPEC. SECTION: _____

I hereby certify that the above-referenced equipment/system has been:

(Check Applicable)

- Installed in accordance with Manufacturer’s recommendations.
- Inspected, checked, and adjusted.
- Serviced with proper initial lubricants.
- Electrical and mechanical connections meet quality and safety standards.
- All applicable safety equipment has been properly installed.
- Functional tests.
- System has been performance tested, and meets or exceeds specified performance requirements. (When complete system of one manufacturer)

Note: Attach any performance test documentation from manufacturer.

Comments: _____

I, the undersigned Manufacturer’s Representative, hereby certify that I am (i) a duly authorized representative of the manufacturer, (ii) empowered by the manufacturer to inspect, approve, and operate his equipment and (iii) authorized to make recommendations required to assure that the equipment furnished by the manufacturer is complete and operational, except as may be otherwise indicated herein. I further certify that all information contained herein is true and accurate.

Date: _____, 20__

Manufacturer: _____

By Manufacturer’s Authorized Representative: _____
(Authorized Signature)

SECTION 01 50 00
CONSTRUCTION FACILITIES AND TEMPORARY CONTROLS

PART 1 GENERAL

1.01 REFERENCES

- A. The following is a list of standards which may be referenced in this section:
1. U.S. Weather Bureau, "Rainfall-Frequency Atlas of the U.S. for Durations from 30 Minutes to 24 Hours and Return Periods from 1 to 100 Years."
 2. U.S. Department of Agriculture, "Urban Hydrology for Small Watersheds."
 3. Federal Emergency Management Agency.
 4. NFPA, National Fire Prevention Standard for Safeguarding Building Construction Operations.

1.02 SUBMITTALS

- A. Administrative Submittals: Copies of permits and approvals for construction as required by Laws and Regulations and governing agencies.
- B. Shop Drawings:
1. Temporary Construction Submittals:
 - a. Parking area plans.
 - b. Contractor's field office, storage yard, and storage building plans, including gravel surfaced area.
 - c. Fencing and protective barrier locations and details.
 - d. Staging area location plan.
 - e. Plan for maintenance of existing plant operations.

1.03 MOBILIZATION

- A. Mobilization shall Include, but Not be Limited to, these Principal Items:
1. Obtaining required permits.
 2. Providing onsite sanitary facilities and potable water facilities as specified and as required by Laws and Regulations, and governing agencies.
 3. Arranging for and erection of Contractor's work and storage yard.
 4. Posting OSHA required notices and establishing safety programs and procedures.
 5. Having Contractor's superintendent at Site full time.

- B. Areas designated for Contractor's temporary facilities shall be coordinated with Engineer and City.

1.04 ONSITE NAS KEY WEST REQUIREMENT

- A. All personnel and vehicles shall be registered with NAS Key West Base security. Badges and decals shall be required of all Contractor personnel for admittance to Site.
- B. No tracked equipment shall be permitted on NAS paved roadways.
- C. Contractor is warned that a Zero Drug Tolerance Policy is in effect on NAS property. All construction workers, truck drivers, and other personnel shall be subject to search and seizure.
- D. All radio controlled equipment shall be coordinated with the NAS prior to use.
- E. NAS approval must be received before radioactive material including radioactive tracers can be brought on to the plant Site.
- F. Any vegetation removal must be coordinated with NAS Key West Natural Resources Office (Code 1883AS). Contact A. Schultz at 293-2911.
- G. Welding permits (i.e., burn permits) shall be obtained and coordinated with NAS Fire Department.
- H. Fleming Key Bridge has a load limit of 32 tons. Contractor to provide certified documents how large material and heavy equipment is to be transported to the construction site.
- I. Contractor will be required to obtain access badges for all personnel working onsite. Forms will be provided to Contractor by Owner. The process requires form submittal 30 days prior to starting of construction. All badged personnel will have a complete background check conducted by NCIS (Naval Criminal Investigation Service). Convicted felons will not be allowed onsite.

PART 2 PRODUCTS

PART 3 EXECUTION

3.01 TEMPORARY UTILITIES

- A. Fire Protection: Furnish and maintain on site adequate firefighting equipment capable of extinguishing incipient fires. Comply with applicable parts of the National Fire Prevention Standard for Safeguarding Building Construction Operations (NFPA No. 241).

B. Cooling and Ventilating:

1. Provide as required to maintain adequate environmental conditions to facilitate progress of the Work, to meet specified minimum conditions for the installation of materials, and to protect materials, equipment, and finishes from damage due to temperature or humidity.
2. Pay all costs of installation, maintenance, operation, removal, and fuel consumed.

3.02 TEMPORARY WATER

- A. The Contractor shall make his own arrangements to obtain suitable water and shall pay all costs.

3.03 SANITARY FACILITIES

- A. The Contractor shall provide and maintain sanitary facilities for his employees and his subcontractors that will comply with the regulations of the local and state departments of health and as directed by the Engineer.

3.04 PROTECTION OF WORK AND PROPERTY

A. General:

1. Comply with Owner's safety rules while on Owner's property.
2. Keep Owner informed of serious onsite accidents and related claims
3. Keep fire hydrants and water control valves free from obstruction and available for use at all times.

B. Site Security: Reference the General Conditions.

C. Barricades and Lights:

1. Provide as necessary to prevent unauthorized entry to construction areas as required to ensure public safety and the safety of Contractor's employees, other employer's employees, and others who may be affected by the Work.
2. Provide to protect existing facilities and adjacent properties from potential damage.
3. Locate to enable access by facility operators and property owners.

D. Waterways: Keep ditches, culverts, and natural drainages continuously free of construction materials and debris.

3.05 TEMPORARY CONTROLS

A. Air Pollution Control:

1. Minimize air pollution from construction operations.
2. Burning of waste materials, rubbish, or other debris will not be permitted on or adjacent to Site.

B. Water Pollution Control:

1. Do not dispose of volatile wastes such as mineral spirits, oil, chemicals, or paint thinner in storm or sanitary drains. Disposal of wastes into streams or waterways is prohibited. Provide acceptable containers for collection and disposal of waste materials, debris, and rubbish.

3.06 ROADS

- A. Maintain access to all roads. Do not block any roadways during construction. If road blockage is anticipated, Contractor shall receive approval from City prior to starting construction.
- B. Maintain drainage ways. Install and maintain culverts to allow water to flow. Provide corrosion-resistant culvert pipe of adequate strength to resist construction loads.

3.07 PARKING AREAS

- A. A parking plan shall be required for the Site.
- B. Control Vehicular parking to preclude interference with public traffic or parking, access by emergency vehicles, Owner's operations, or construction operations. No parking along roadways shall be allowed.

3.08 CLEANING DURING CONSTRUCTION

- A. In accordance with General Conditions, as may be specified in Specification sections, and as required herein.
- B. Wet down exterior surfaces prior to sweeping to prevent blowing of dust and debris. At least weekly, sweep all floors (basins, tunnels, platforms, walkways, roof surfaces), and pick up all debris and dispose.

- C. Provide approved containers for collection and disposal of waste materials, debris, and rubbish. At least at weekly intervals, dispose of such waste materials, debris, and rubbish offsite.
- D. At least weekly, brush sweep the entry drive and roadways, and all other streets and walkways affected by Work and where adjacent to Work.

END OF SECTION

**SECTION 01 77 00
CONTRACT CLOSEOUT**

PART 1 GENERAL

1.01 SUBMITTALS

- A. Quality Control Submittals: Written procedures for maintaining and markup of record documents.
- B. Contract Closeout Submittals: Submit prior to application for final payment.
 - 1. Record Documents: As required in the General Conditions.
 - 2. Approved Shop Drawings and Samples: As required in the General Conditions.
 - 3. Special Bonds, Special Warranties, and Service Agreements.
 - 4. Consent of Surety to Final Payment: As required in the General Conditions.
 - 5. Releases or Waivers of Liens and Claims: As required in the General Conditions.
 - 6. Releases from Agreements.
 - 7. Final Application for Payment: Submit in accordance with procedures and requirements stated in Section 01 29 00, Payment Procedures.
 - 8. Spare Parts and Special Tools: As required by individual Specification sections.

1.02 RECORD DOCUMENTS

- A. Quality Assurance:
 - 1. Furnish qualified and experienced person, whose duty and responsibility shall be to maintain record documents.
 - 2. Accuracy of Records:
 - a. Coordinate changes within record documents, making legible and accurate entries on each sheet of Drawings and other documents where such entry is required to show change.
 - b. Purpose of Project record documents is to document factual information regarding aspects of Work, both concealed and visible, to enable future modification of Work to proceed without lengthy and expensive site measurement, investigation, and examination.
 - 3. Make entries within 24 hours after receipt of information that a change in Work has occurred.

4. Prior to submitting each request for progress payment, request Engineer's review and approval of current status of record documents. Failure to properly maintain, update, and submit record documents may result in a deferral by Engineer to recommend the whole or any part of the Contractor's Application for Payment, either partial or final.
 - a. All supplied data collections, as-builts, drawings, files to be compatible with ersi ArcGIS 10.2.2 Software. The Owner's current computing environment consists of *Microsoft SQL Server – Windows 7/Server 2008 – ERSI GIS Platform*. Interfaces and Integrations:
 - 1) The City of Key West uses a number of software applications critical to its core operation and mission. The proposed mobile asset data collection solution will need to interface with these existing platforms: Arc Collector; ArcGIS Online and ArcMap 10.2.
 - 2) Contact Nicholas Osterhoudt, City GIS Manager, at 305-809-3721 with software-related questions.

1.03 RELEASES FROM AGREEMENTS

- A. Furnish Owner written releases from property owners or public agencies where side agreements or special easements have been made, or where Contractor's operations have not been kept within the Owner's construction right-of-way.
- B. In the event Contractor is unable to secure written releases, inform the Owner of the reasons:
 1. Owner or its representatives will examine the Site, and Owner will direct Contractor to complete Work that may be necessary to satisfy terms of the easement.
 2. Should Contractor refuse to perform this Work, Owner reserves the right to have it done by separate contract and deduct the cost of same from the Contract Price, or require the Contractor to furnish a satisfactory Bond in a sum to cover legal claims for damages.
 3. When Owner is satisfied that Work has been completed in agreement with the Contract Documents and terms of easements, the right is reserved to waive the requirement for written release if: (i) Contractor's failure to obtain such statement is due to the grantor's refusal to sign, and this refusal is not based upon any legitimate claims that Contractor has failed to fulfill the terms of the easement, or (ii) Contractor is unable to contact or has had undue hardship in contacting the grantor.

PART 2 PRODUCTS (NOT USED)**PART 3 EXECUTION**

3.01 MAINTENANCE OF RECORD DOCUMENTS

A. General:

1. Promptly following commencement of Contract Times, secure from Engineer at no cost to Contractor, one complete set of Contract Documents. Drawings will be full size.
2. Delete Engineer title block and seal from all documents.
3. Label or stamp each record document with title, "RECORD DOCUMENTS," in neat large printed letters.
4. Record information concurrently with construction progress and within 24 hours after receipt of information that change has occurred. Do not cover or conceal Work until required information is recorded.

B. Preservation:

1. Maintain documents in a clean, dry, legible condition and in good order. Do not use record documents for construction purposes.
2. Make documents and Samples available at all times for observation by Engineer.

C. Making Entries on Drawings:

1. Using an erasable colored pencil (not ink or indelible pencil), clearly describe change by graphic line and note as required.
 - a. Color Coding:
 - 1) Green when showing information deleted from Drawings.
 - 2) Red when showing information added to Drawings.
 - 3) Blue and circled in blue to show notes.
2. Date entries.
3. Call attention to entry by "cloud" drawn around area or areas affected.
4. Legibly mark to record actual changes made during construction, including, but not limited to:
 - a. Locate existing facilities, piping, equipment, and items critical to the interface between existing physical conditions or construction and new construction.
 - b. Changes made by Addenda and Field Orders, Work Change Directive, Change Order, Written Amendment, and Engineer's written interpretation and clarification using consistent symbols for each and showing appropriate document tracking number.

5. Dimensions on Schematic Layouts: Show on record drawings, by dimension, the centerline of each run of items such as are described in previous subparagraph above.
 - a. Clearly identify the item by accurate note such as “cast iron drain,” “galv. water,” and the like.
 - b. Show, by symbol or note, vertical location of item (“under slab,” “in ceiling plenum,” “exposed,” and the like).
 - c. Make identification so descriptive that it may be related reliably to Specifications.

3.02 FINAL CLEANING

- A. At completion of Work at each Site or of a part thereof and immediately prior to Contractor's request for certificate of Substantial Completion; or if no certificate is issued, immediately prior to Contractor's notice of completion, clean entire site or parts thereof, as applicable.
 1. Leave the Work and adjacent areas affected in a cleaned condition satisfactory to Owner and Engineer.
 2. Remove grease, dirt, dust, paint or plaster splatter, stains, labels, fingerprints, and other foreign materials from exposed surfaces.
 3. Repair, patch, and touchup marred surfaces to specified finish and match adjacent surfaces.
 4. Broom clean exterior paved driveways and parking areas.
 5. Hose clean sidewalks, loading areas, and others contiguous with principal structures.
 6. Rake clean all other surfaces.
 7. Leave water courses, gutters, and ditches open and clean.
- B. Use only cleaning materials recommended by manufacturer of surfaces to be cleaned.

END OF SECTION

SECTION 03 30 01
REINFORCED CONCRETE

PART 1 GENERAL

1.01 REFERENCES

- A. The following is a list of standards which may be referenced in this section:
1. American Concrete Institute (ACI):
 - a. 301, Specifications for Structural Concrete for Buildings.
 - b. 305R, Hot Weather Concreting.
 - c. 306R, Cold Weather Concreting.
 - d. 318/318R, Building Code Requirements for Structural Concrete and Commentary.
 - e. 347, Formwork for Concrete.
 2. ASTM International (ASTM):
 - a. A497, Standard Specification for Steel Welded Wire Fabric, Deformed, for Concrete Reinforcement.
 - b. A615, Standard Specification for Deformed and Plain Billet-Steel Bars for Concrete Reinforcement.
 - c. C31, Standard Practice for Making and Curing Concrete Test Specimens in the Field.
 - d. C94, Standard Specification for Ready-Mixed Concrete.
 - e. C150, Standard Specification for Portland Cement.
 - f. C260, Standard Specification for Air-Entraining Admixtures for Concrete.
 - g. C309, Standard Specification for Liquid Membrane-Forming Compounds for Curing Concrete.
 - h. C494, Standard Specification for Chemical Admixtures for Concrete.
 - i. C618, Standard Specification for Fly Ash and Raw or Calcined Natural Pozzolan for Use as a Mineral Admixture in Portland Cement Concrete.
 - j. D994, Standard Specification for Preformed Expansion Joint Filler for Concrete (Bituminous Type).
 3. Concrete Reinforcing Steel Institute (CRSI):
 - a. Manual of Standard Practice.
 - b. Recommended Practice for Placing Reinforcing Bars.

1.02 SUBMITTALS

A. Action Submittals:

1. Reinforcing steel in accordance with CRSI Manual of Standard Practice.
2. Curing compound data.
3. Complete data on the concrete mix, including aggregate gradations and admixtures, in accordance with ASTM C94.

B. Informational Submittals:

1. Manufacturer's application instructions for curing compound.
2. Ready-mix delivery tickets for each truck in accordance with ASTM C94.

1.03 QUALITY ASSURANCE

A. Formwork: Unless otherwise specified, follow the recommendations of ACI 347.

B. Concrete and Reinforcement: Unless otherwise specified, meet the requirements of ACI 301 and ACI 318/318R.

C. Hot Weather Concreting: Conform to ACI 305R.

D. Cold Weather Concreting: Conform to ACI 306R.

1.04 ENVIRONMENTAL REQUIREMENTS

A. Do not place concrete when the ambient temperature is below 40 degrees F or approaching 40 degrees F and air temperature less than 40 degrees F for the first 7 days, without special protection to keep concrete above 40 degrees F.

B. Do not use curing compound where solvents in the curing compounds are prohibited by state or federal air quality laws. Use only water curing methods.

PART 2 PRODUCTS

2.01 CONCRETE

A. Ready-mixed meeting ASTM C94, Option A.

B. Portland Cement: ASTM C150, Type II.

C. Admixtures:

1. Air-Entraining: ASTM C260.
2. Water-Reducing: ASTM C494, Type A or Type D.
3. Superplasticizers: ASTM C494, Type F or Type G.
4. Fly Ash: ASTM C618, Class C or Class F.

D. Mix Design:

1. Minimum Allowable 28-day Compressive Field Strength: 4,000 psi when cured and tested in accordance with ASTM C31 and ASTM C39.
2. Coarse Aggregate Size: 1 inch and smaller.
3. Slump Range: 3 to 5 inches.
4. Air Entrainment: Between 3 and 6 percent by volume. Use 4 percent minimum for concrete placed under requirements of cold weather concreting.
5. Water Reducers: Use in concrete without plasticizers.

E. Mixing: Minimum 70 and maximum 270 revolutions of mixing drum. Nonagitating equipment is not allowed.

2.02 REINFORCING STEEL

A. Deformed Bars: ASTM A615, Grade 60.

B. Welded Wire Fabric: ASTM A497.

2.03 ANCILLARY MATERIALS

A. Expansion Joint Filler: ASTM D994, 1/2-inch thick, or as shown.

B. Nonshrink Grout:

1. Color: To match concrete.
2. Manufacturers and Products:
 - a. Master Builder Co., Cleveland, OH; Master Flow 928.
 - b. Euclid Chemical Co., Cleveland, OH; Hi-flow Grout.

C. Curing Compound:

1. Water-based, high solids content nonyellowing curing compound meeting requirements of ASTM C309 and ASTM C1315.
 - a. Moisture Loss: 0.40 kg/square meter/72 hours maximum.
 - b. Capable of meeting moisture retention at manufacturer's specified application rate.

2. Manufacturers and Products:
 - a. Chemrex, Inc., Shakopee, MN; Masterkure.
 - b. Euclid Chemical Co., Cleveland, OH; Super Diamond Clear VOX.
 - c. WR Meadows, Inc., Hampshire, IL; VOCOMP-30.
 - d. Vexcon Chemical, Inc.; Philadelphia, PA; Starseal 1315.
 - e. Dayton Superior; Safe Cure and Seal 30 percent.

PART 3 EXECUTION

3.01 FORMWORK

A. Form Materials:

1. Use hard plastic finished plywood for exposed areas, and new shiplap or plywood for unexposed areas.
2. Earth cuts may be used for forming footings.

B. Form Ties:

1. Fixed conical or spherical type inserts that remain in contact with forming material and allow for dry packing of form tie holes.
2. Ties shall withstand pressures and limit deflection of forms to acceptable limits.
3. Wire ties are not acceptable.

C. Construction:

1. In accordance with ACI 347.
2. Make joints tight to prevent escape of mortar and to avoid formation of fins.
3. Brace as required to prevent distortion during concrete placement.
4. On exposed surfaces locate form ties in uniform pattern or as shown.
5. Construct so ties remain embedded in the wall with no metal within 1 inch of concrete surface when forms, inserts, and tie ends are removed.

D. Form Removal:

1. Remove after concrete has attained 28-day strength, or approval is obtained in writing from Engineer.
2. Remove forms with care to prevent scarring and damaging the surface.
3. Prior to form removal, provide thermal protection for concrete being placed under the requirements of cold weather concreting.

3.02 PLACING REINFORCING STEEL

- A. Unless otherwise specified, place reinforcing steel in accordance with CRSI Recommended Practice for Placing Reinforcing Bars.
- B. Splices and Laps:
 - 1. Top Bars: Horizontal bars placed such that 12 inches of fresh concrete is cast below in single placement.
 - 2. Horizontal wall bars are considered top bars.
 - 3. Lap top bars 42 diameters or minimum 24 inches.
 - 4. Lap all other bars 30 diameters or minimum 18 inches.
 - 5. Tie splices with 18-gauge annealed wire as specified in CRSI Standard.

3.03 PLACING CONCRETE

- A. Place concrete in accordance with ACI 301.
- B. Prior to placing concrete, remove water and debris and foreign material from forms. Check reinforcing steel for proper placement and correct discrepancies.
- C. Before depositing new concrete on old concrete, clean surface using sandblast or bushhammer or other mechanical means to obtain a 1/4-inch rough profile, and pour a cement-sand grout to minimum depth of 1/2 inch over surface. Proportion 1 part cement to 2.5 parts sand by weight.
- D. Place concrete as soon as possible after leaving mixer, without segregation or loss of ingredients, without splashing forms or steel above, and in layers not over 2 feet deep. Place within 1-1/2 hours after adding cement to mix.
- E. Eight feet maximum vertical drop to final placement, when not guided with chutes or other devices to prevent segregation due to impact with reinforcing.

3.04 COMPACTION

- A. Vibrate Concrete as Follows:
 - 1. Apply approved vibrator at points spaced not farther apart than vibrator's effective radius.
 - 2. Apply close enough to forms to vibrate surface effectively but not damage form surfaces.
 - 3. Vibrate until concrete becomes uniformly plastic.
 - 4. Vibrator must penetrate fresh placed concrete and into previous layer of fresh concrete below.

3.05 FINISHING

- A. Floor Slabs and Tops of Walls:
 - 1. Screed surfaces to true level planes.
 - 2. After initial water has been absorbed, float with wood float and trowel with steel trowel to smooth finish free from trowel marks.
 - 3. Do not absorb wet spots with neat cement.
- B. Unexposed Slab Surfaces: Screed to true surface, bull float with wood float, and wood trowel to seal surface.
- C. Tolerances: Floors shall not vary from level or true plane more than 1/4 inch in 10 feet when measured with a straightedge.
- D. Exterior Infill Slabs:
 - 1. Bull float with wood float, wood trowel, and lightly trowel with steel trowel.
 - 2. Finish with broom to obtain nonskid surface.
 - 3. Finish exposed edges with steel edging tool.

3.06 FINISHING AND PATCHING FORMED SURFACES

- A. Cut out honeycombed and defective areas.
- B. Cut edges perpendicular to surface at least 1 inch deep. Do not feather edges. Soak area with water for 24 hours.
- C. Patch with shotcrete or low pressure mortar as specified in Section 03720, Vertical and Overhead Concrete Surface Repair Systems.
- D. Finish surfaces to match adjacent concrete.
- E. Keep patches damp for minimum 7 days or spray with curing compound to minimize shrinking.
- F. Fill form tie holes with nonshrink grout.

3.07 PROTECTION AND CURING

- A. Protect fresh concrete from direct rays of sunlight, drying winds, and wash by rain.
- B. Keep concrete slabs continuously wet for a 7-day period. Intermittent wetting is not acceptable.

- C. Use curing compound only where approved by Engineer. Cure formed surfaces with curing compound applied in accordance with manufacturer's directions as soon as forms are removed and finishing is completed.
- D. Remove and replace concrete damaged by freezing.

3.08 FIELD TESTS

- A. Evaluation of Concrete Field Strength: In accordance with ACI 318/318R.

END OF SECTION

SECTION 05 50 00
METAL FABRICATIONS-LADDERS

PART 1 GENERAL

1.01 REFERENCES

- A. The following is a list of standards which may be referenced in this section:
1. The Aluminum Association, Inc. (AA): The Aluminum Design Manual.
 2. American Ladder Institute (ALI): A14.3, Ladders - Fixed - Safety Requirements.
 3. American National Standards Institute (ANSI).
 4. American Society of Safety Engineers (ASSE): A10.11, Safety Requirements for Personnel and Debris Nets.
 5. American Welding Society (AWS):
 - a. D1.1/D1.1M, Structural Welding Code - Steel.
 - b. D1.2/D1.2M, Structural Welding Code - Aluminum.
 - c. D1.6/D1.6M, Structural Welding Code - Stainless Steel.
 6. ASTM International (ASTM):
 - a. A193/A193M, Standard Specification for Alloy-Steel and Stainless Steel Bolting for High Temperature or High Pressure Service and Other Special Purpose Applications.
 - b. A194/A194M, Standard Specification for Carbon and Alloy Steel Nuts for Bolts for High Pressure or High Temperature Service, or Both.
 - c. B209, Standard Specification for Aluminum and Aluminum-Alloy Sheet and Plate.
 - d. B308/B308M, Standard Specification for Aluminum-Alloy 6061-T6 Standard Structural Profiles.
 - e. B429/B429M, Standard Specification for Aluminum-Alloy Extruded Structural Pipe and Tube.
 - f. B632/B632M, Standard Specification for Aluminum-Alloy Rolled Tread Plate.
 - g. C881/C881M, Standard Specification for Epoxy-Resin-Base Bonding Systems for Concrete.
 - h. D1056, Standard Specification for Flexible Cellular Materials - Sponge or Expanded Rubber.
 - i. F436, Standard Specification for Hardened Steel Washers.
 - j. F468, Standard Specification for Nonferrous Bolts, Hex Cap Screws, and Studs for General Use.
 - k. F593, Standard Specification for Stainless Steel Bolts, Hex Cap Screws, and Studs.
 - l. F594, Standard Specification for Stainless Steel Nuts.
 - m. F844, Standard Specification for Washers, Steel, Plain (Flat), Unhardened for General Use.

- n. F1554, Standard Specification for Anchor Bolts, Steel, 36, 55, and 105-ksi Yield Strength.
- 7. International Code Council Evaluation Service (ICC-ES):
 - a. AC01, Acceptance Criteria for Expansion Anchors in Masonry Elements.
 - b. AC106, Acceptance Criteria for Predrilled Fasteners (Screw Anchors) in Masonry Elements.
 - c. AC193, Acceptance Criteria for Mechanical Anchors in Concrete Elements.
 - d. AC308, Acceptance Criteria for Post-Installed Adhesive Anchors in Concrete Elements.
 - e. AC70, Acceptance Criteria for Fasteners Power-driven into Concrete, Steel and Masonry Elements.
- 8. Occupational Safety and Health Administration (OSHA):
 - a. 29 CFR 1910.27, Fixed Ladders.
 - b. 29 CFR 1926.502, Fall Protection Systems Criteria and Practices.

1.02 DEFINITIONS

- A. Concrete Anchor: Post-installed concrete anchors listed in this specification.
- B. Exterior Area: Location not protected from weather by building or other enclosed structure.
- C. Masonry Anchor: Post-installed masonry anchors listed in this specification.

1.03 SUBMITTALS

- A. Action Submittals:
 - 1. Shop Drawings:
 - a. Each aluminum ladder drawn in scale specifically for each of two locations showing all dimensions, grade condition, fastening system to existing concrete walls, fall protection, cage, and cross over parapet platform design including welding and fastener information.
 - b. Specific instructions for concrete anchor installation, including drilled hole size, preparation, placement, procedures, and instructions for safe handling of anchoring systems.
- B. Informational Submittals:
 - 1. Concrete and Masonry Post-Installed Anchors:
 - a. Manufacturer's product description and printed installation instructions.
 - b. Current ICC-ES Report for each type of post-installed anchor to be used.
 - c. Adhesive anchor installer certification.

2. Ladders: Letter of certification that ladder meets OSHA 29 CFR 1910.27 requirements.

1.04 QUALITY ASSURANCE

A. Qualifications:

1. Adhesive Anchor Installer: Trained to install adhesive anchors in accordance with manufacturer's printed installation instructions.

1.05 DELIVERY, STORAGE, AND HANDLING

- A. Insofar as practical, factory assemble specified items. Assemblies, because of necessity, have to be shipped unassembled shall be packaged and tagged in manner that will protect materials from damage and will facilitate identification and field assembly.
- B. Store fabricated items in dry area, not in direct contact with ground.
- C. Store adhesives anchors at service temperature ranges recommended by manufacturer.

PART 2 PRODUCTS

2.01 GENERAL

- A. Bolts, Washers, and Nuts: Use stainless steel, hot-dip galvanized steel, zinc-plated steel, and aluminum material types as indicated in Fastener Schedule at end of this section.

Stainless Steel:	
Bolts, threaded rods, anchor bolts, and anchor studs	F593, AISI Type 316, Condition CW
Nuts	F594, AISI Type 316, Condition CW
Steel Bolts and Nuts:	
Carbon steel	A307 bolts, with A563 nuts
High-strength	A325, Type 1 bolts, with A563 nuts
Anchor bolts and rods	F1554, Grade 36, with weldability supplement S1.
Aluminum plates and structural shapes	B209 and B308/B308M, Alloy 6061-T6
Aluminum bolts and nuts	F468, Alloy 2024-T4
Cast iron	A48/A48M, Class 35

2.02 POST-INSTALLED CONCRETE ANCHORS

A. General:

1. AISI Type 316 stainless, hot-dip galvanized, or zinc-plated steel, as shown in Fastener Schedule at end of this section.
2. Current ICC-ES Report indicating acceptance in accordance with IBC 2006 and IBC 2009 for anchors at structural applications in cracked concrete.
3. Anchors shall be suitable for long-term loads, as well as for wind and seismic loads.
4. Displacement-Controlled Expansion Anchors (Drop-in Anchors):
 - a. Self-drilling anchors, snap-off or flush type, zinc-plated.
 - b. Nondrilling Anchors: Flush type for use with zinc-plated or stainless steel bolt, or stud type with projecting threaded stud.
 - c. Manufacturers and Products:
 - 1) ITW Ramset/Red Head, Addison, IL; Multi-Set II Drop-In and Self Drill Anchor.
 - 2) Hilti, Inc., Tulsa, OK; Hilti HDI Drop-In Anchor.
 - 3) Powers Fasteners, Brewster, NY; Steel Drop-In Anchor.
 - 4) Simpson Strong-Tie Co., Inc., Pleasanton, CA; Drop-In Anchor.
5. Self-Tapping Concrete Screw Anchors:
 - a. When used in sustained tension applications (such as overhead or cantilevered applications) shall have current ICC-ES Report that demonstrates compliance with ICC-ES AC193 for cracked concrete.
 - b. Manufacturers and Products:
 - 1) Powers Fasteners, Brewster, NY; Wedge-Bolt+ (ESR-2526).
 - 2) Powers Fasteners, Brewster, NY; Vertigo+ Rod Hanger Screw Anchor (ESR-2989).
 - 3) Powers Fasteners, Brewster, NY; Snake+ Flush Mount Screw Anchor (ESR-2272).
 - 4) Hilti, Inc., Tulsa, OK; HUS-EZ Screw Anchor (ESR-3027).
 - 5) Simpson Strong-Tie Co., Inc., Pleasanton, CA; Titen HD Screw Anchor (ESR-2713).
6. Light-Duty Torque Controlled Expansion Anchors (Sleeve Anchors):
 - a. Manufacturers and Products:
 - 1) ITW Ramset/Red Head, Addison, IL; Dynabolt Hex Nut Sleeve Anchor.
 - 2) Powers Fasteners, Brewster, NY; Lok-Bolt AS.
 - 3) Simpson Strong-Tie Co., Inc., Pleasanton, CA; Sleeve-All Hex Head Anchor.
 - 4) Wej-It Corp., Tulsa, OK; Wej-It Sleeve Anchor.

7. Heavy-Duty Torque Controlled Expansion Anchors (Sleeve Anchors):
 - a. Manufacturers and Products:
 - 1) Powers Fasteners, Brewster, NY; Power-Bolt+ Anchor.
 - 2) Hilti, Inc., Tulsa, OK; HSL-3 Heavy Duty Sleeve Anchor.

2.03 POST-INSTALLED MASONRY ANCHORS

- A. General: AISI Type 316 stainless, hot-dip galvanized, or zinc-plated steel, as shown in Fastener Schedule at end of this section.
- B. Current ICC Evaluation Report indicating acceptance in accordance with IBC 2006 for anchors at structural applications in masonry.
- C. Manufacturers and Products:
 1. Hilti, Inc., Tulsa, OK; Kwik-Bolt-3 (KB-3) (ESR-1385), for grout-filled masonry.
 2. Powers Fasteners, Brewster NY, T308+ Epoxy Adhesive Anchoring System in Unreinforced Masonry (ESR-3149), Power-Stud+ SD1 (ESR-2966) for grout-filled masonry, Wedgebolt+ (ESR-1678) for grout-filled masonry.

2.04 LADDERS

- A. Fabricate ladders with rails, rungs, landings, and cages to meet applicable requirements of OSHA, CFR Part 1910.27, and ALI A14.3.
 1. Concentrated load of 200 pounds loads imposed by persons occupying ladder shall be considered to be concentrated at such points as will cause maximum stress in structural member being considered.
 2. Weight of ladder and attached appurtenances together with live load shall be considered in design of rails and fastenings.
 3. Self-closing gates at landings at grade elevation only.
 4. Ladders equal to or exceeding 20 feet-0 inches in height will be provided with OSHA approved cage.
- B. Flat Bar Ladder:
 1. Punch rails, pass rungs through rails, and weld on outside.
 2. Weld brackets to ladder for fastening ladder to wall.
 3. Hot-dip galvanize steel after fabrication in accordance with ASTM A123/A123M and ASTM A385/A385M.

C. Aluminum Pre-engineered Pipe Ladder:

1. Rungs:
 - a. Aluminum extrusions of Alloy 6063-T6.
 - b. Nonslip grip surface, 1-inch wide flat top, and semicircular bottom with mill finish.
2. Side Rails: ASTM B429/B429M, Alloy 6063-T6, 1-1/2 inches, Schedule 40 pipe with anodized finish, AA M32-C22-A41.
3. Ladder Attachments and Cage Assembly Fasteners: Stainless steel.
4. Welded, pop riveted, or glued construction is not acceptable.
5. Fabricate to longest length as practical but not to exceed 24 feet.
6. Furnish support attachments to side rails at 6 feet maximum spacing.
7. Manufacturer: Thompson Fabricating Co. Inc., Tarrant, AL.

2.05 SAFETY CLIMB DEVICE

A. General:

1. Should the new ladder equal or exceed 20 feet 0 inches vertically, then an OSHA approved and defined ladder cage will be installed in lieu of Safety Climb Device in that section of ladder.
2. Conforms to ALI A14.3 and OSHA CFR Part 1910.27.
3. Belt and harness shall withstand minimum drop test of 250 pounds in 6-foot free fall.
4. Fall Prevention System Material: Aluminum 6061-T6

B. Components and Accessories:

1. Main Components: Sleeve or trolley, safety harness, and carrier or climbing rail.
2. Ladder rung clamps with aluminum AISI Type 316, mounting brackets and hardware.
3. Removable extension kit with tiedown rod or trolley gate, mandrel, and carrier rail for ladders under manholes and hatches.

C. Manufacturers and Products:

1. Miller Equipment, Franklin, PA; Sure Track Rail System.
2. TS Products, St. Charles, IL; TS Safety Rail System.

2.06 ACCESSORIES

A. Antiseizing Lubricant for Stainless Steel Threaded Connections:

1. Suitable for potable water supply.
2. Resists washout.

3. Manufacturers and Products:
 - a. Bostik, Middleton, MA; Neverseez.
 - b. Saf-T-Eze Div., STL Corp., Lombard, IL; Anti-Seize.

2.07 FABRICATION

A. General:

1. Finish exposed surfaces smooth, sharp, and to well-defined lines.
2. Furnish necessary rabbets, lugs, and brackets so work can be assembled in neat, substantial manner.
3. Conceal fastenings where practical; where exposed, flush countersink.
4. Drill metalwork and countersink holes as required for attaching hardware or other materials.
5. Grind cut edges smooth and straight. Round sharp edges to small uniform radius. Grind burrs, jagged edges, and surface defects smooth.
6. Fit and assemble in largest practical sections for delivery to Site.

B. Materials: Fabricate aluminum in accordance with AA Specifications for Aluminum Structures–Allowable Stress Design.

C. Welding:

1. Weld connections and grind exposed welds smooth. When required to be watertight, make welds continuous.
2. Welded fabrications shall be free from twisting or distortion caused by improper welding techniques.
3. Aluminum: Meet requirements of AWS D1.2/D1.2M.
4. Welded Anchor Studs: Prepare surface to be welded and weld with stud welding gun in accordance with AWS D1.1/D1.1M, Section 7, and manufacturer's instructions.
5. Complete welding before applying finish.
6. Electrolytic Protection: Coat surfaces of galvanized steel and aluminum fabricated items to be in direct contact with concrete, grout, masonry, or dissimilar metals unless indicated otherwise.
 - a. Surface Preparation: Solvent clean (SP1).
 - b. Primer: Paint in accordance with manufacturer's recommendations.
 - c. Bituminous Paint: 1 coat, 10 minimum dry film thickness in mils.

D. Fitting: Where movement of fabrications is required or shown, cut, fit, and align items for smooth operation. Make corners square and opposite sides parallel.

E. Accessories: Furnish as required for a complete installation. Fasten by welding or with stainless steel bolts or screws.

PART 3 EXECUTION

3.01 INSTALLATION OF METAL FABRICATIONS

A. General:

1. Install metal fabrications plumb and level, accurately fitted, free from distortion or defects.
2. Install rigid, substantial, and neat in appearance.
3. Install manufactured products in accordance with manufacturer's recommendations.
4. Obtain Engineer approval prior to field cutting steel members or making adjustments not scheduled.

B. Aluminum:

1. Do not remove mill markings from concealed surfaces.
2. Remove inked or painted identification marks on exposed surfaces not otherwise coated after installed material has been inspected and approved.
3. Fabrication, mechanical connections, and welded construction shall be in accordance with the AA Aluminum Design Manual.

C. Pipe Sleeves:

1. Provide where pipes pass through concrete or masonry.
2. Holes drilled with a rotary drill may be provided in lieu of sleeves in existing walls.
3. Provide center flange for water stoppage on sleeves in exterior or water-bearing walls.
4. Provide rubber caulking sealant or a modular mechanical unit to form watertight seal in annular space between pipes and sleeves.

D. Steel Lintels and Shelf Angles: Provide as required for support of masonry and other construction not attached to structural steel framing, unless otherwise shown on Drawings.

3.02 CAST-IN-PLACE ANCHOR BOLTS

- A. Locate and hold anchor bolts in place with templates at time concrete is placed.
- B. Use anchor bolt sleeves for location adjustment and provide two nuts and one washer per bolt of same material as bolt.
- C. Minimum Bolt Size: 1/2-inch diameter by 12 inches long, unless otherwise shown.

3.03 CONCRETE AND MASONRY POST-INSTALLED ANCHORS

- A. Begin installation only after concrete or masonry to receive anchors has attained design strength.
- B. Install in accordance with manufacturer's instructions.
- C. Provide minimum embedment, edge distance, and spacing as follows, unless indicated otherwise by anchor manufacturer's instructions or shown otherwise on Drawings:

Anchor Type	Minimum Embedment (Bolt Diameters)	Minimum Edge Distance (Bolt Diameters)	Minimum Spacing (Bolt Diameters)
Expansion	9	6	12
Undercut	9	12	16
Adhesive	9	9	13.5

3.04 SAFETY CLIMB DEVICE SYSTEM

- A. Provide for each ladder where unbroken height between levels exceeds 20 feet, or at lesser height where indicated on Drawings.
- B. Install in accordance with manufacturer's instructions.
- C. Furnish additional accessories required to complete system for each ladder.
- D. Furnish one harness for each ladder equipped with safety climb device.
- E. Furnish pivot section at platforms, landings, and roofs.
- F. When installed to required height, fall prevention system shall be rigid and an integral part of the structure.

3.05 FASTENER SCHEDULE

- A. Unless indicated otherwise on Drawings, provide fasteners as follows:

Service Use and Location	Product	Remarks
1. Anchor Bolts Cast Into Concrete for Structural Steel, Metal Fabrications and Castings		
Exterior and Interior Wet Areas	Stainless steel headed anchor bolts	
2. Anchor Bolts Cast Into Concrete for Equipment Bases		

Service Use and Location	Product	Remarks
3. Drilled Anchors for Metal Components to Cast-in-Place Concrete (e.g., Ladders, Handrail Posts, Electrical Panels, and Equipment)		
4. Anchors in Grout-Filled Concrete Masonry Units		
Exterior and interior wet and dry areas	Hot-dip galvanized steel headed anchor bolts, zinc-plated or stainless steel sleeve anchors, or stainless steel adhesive anchors	
5. Connections of Aluminum Components		
Submerged, exterior and interior wet and dry areas	Stainless steel bolted connections, unless otherwise specified with equipment	
6. All Others		
Exterior and interior wet and dry areas	Stainless steel fasteners	

END OF SECTION

SECTION 07 52 17
MODIFIED BITUMEN SHEET ROOFING OVER CONCRETE SUBSTRATE

PART 1 GENERAL

1.01 DESCRIPTION OF WORK

- A. Partial Existing Administration Building Reroofing (Primary scope of work).
- B. Existing Chlorine Building Reroofing (Alternate 1 scope of work).

1.02 PRIMARY SCOPE OF WORK—ADMINISTRATION BUILDING

- A. Demolition for Administration Building Roof:
 - 1. The existing roof system is to be removed down to the concrete deck.
 - 2. Damaged or spalled concrete on the top and sides of the existing exposed concrete parapet is to be repaired.
 - 3. Existing roof drain assemblies are to be removed and replaced above the level of the concrete deck. Inlet opening to drain piping to be examined for appropriate condition for installing new roof drain assemblies.
 - 4. Existing roof curbs are to be removed and those openings existing, but no longer used, are to be filled flush with concrete.
 - 5. Curbs designated for replacement supporting equipment shall be replaced. Supported equipment shall be removed and reinstalled on new support curbs.
 - 6. Condition of the concrete deck to be assessed after removal of the existing roof and prior to start of new construction.
 - 7. Existing lightning protection system is to be removed and stored for re-installation after the new roof system is installed.
 - 8. Contractor to dispose of all removed material in an approved landfill.
- B. New construction based on:
 - 1. SBS modified bitumen roofing assembly.
 - 2. New tested aluminum coping system.
 - 3. Slope of roof to be minimum 1/4-inch per foot slope to existing roof drains.
 - 4. New roof assembly will meet required developed positive and negative roof pressures stated on drawings but must follow system approved by shop drawing meeting the pressures as stated and documents by third party testing.
 - 5. Re-install existing lightning system and replace pieces that were damaged during removal.

1.03 ALTERNATE 1—EXISTING CHLORINE BUILDING

- A. The demolition and reroofing of the Chlorine Building is an alternate addition to the reroofing of the Administration Building and has similar scope.

1.04 REFERENCES

- A. The following is a list of standards that may be referenced in this section:

1. American Wood Preservers' Association (AWPA): C2, Lumber, Timbers, Bridge Ties, and Mine Ties-Preservative Treatment by Pressure Processes.
2. ASTM International (ASTM):
 - a. C552, Standard Specification for Cellular Glass Thermal Insulation.
 - b. C578, Standard Specification for Preformed, Cellular Polystyrene Thermal Insulation.
 - c. C726, Standard Specification for Mineral Fiber Roof Insulation Board.
 - d. C728, Standard Specification for Perlite Thermal Insulation Board.
 - e. C1289, Standard Specification for Faced Rigid Cellular Polyisocyanurate Thermal Insulation Board.
 - f. D41, Standard Specification for Asphalt Primer Used in Roofing, Dampproofing, and Waterproofing.
 - g. D312, Standard Specification for Asphalt Used in Roofing.
 - h. D1227, Standard Specification for Emulsified Asphalt Used as a Protective Coating for Roofing.
 - i. D4586, Standard Specification for Asphalt Roof Cement, Asbestos Free.
 - j. D4601, Standard Specification for Asphalt-Coated Glass Fiber Base Sheet Used in Roofing.
 - k. D6162, Standard Specification for Styrene Butadiene Styrene (SBS) Modified Bituminous Sheet Materials Using a Combination of Polyester and Glass Fiber Reinforcements.
 - l. D6164, Standard Specification for Styrene Butadiene Styrene (SBS) Modified Bituminous Sheet Materials Using Polyester Reinforcements.
3. Factory Mutual (FM): Loss Prevention Data.
 - a. 1-28, Insulated Steel Deck.
 - b. 1-288, Wind Uplift Pressure on Roofs.
4. Federal Specifications (FS):
 - a. HH-I/GEN, (Basic; Am 1; Notice 1) Insulation Board, Thermal, Faced, Polyurethane or Polyisocyanurate.

- b. HH-I/2, (Basic; Am 1) Insulation Board, Thermal, Polyurethane or Polyisocyanurate Faced with Asphalt/Organic Felt, Asphalt/Asbestos Felt or Asphalt/Glass Fiber Felt on Both Sides of the Foam.
- 5. National Roofing Contractors Association (NRCA): Handbook of Accepted Roofing Knowledge (HARK).
- 6. 2010 Florida Building Code.

1.05 SUBMITTALS

A. Prior to Award of Contract:

- 1. Letter from the proposed primary roofing manufacturer confirming that the bidder identified Subcontractor is a Contractor authorized to install the approved roof assembly.
- 2. Letter from the primary roofing manufacturer stating that the proposed roofing application will meet stated hurricane criteria with testing documents attached.
- 3. Note: It is acknowledged that this roof will exceed the developed pressures of the ultimate wind speed of 200 miles per hour in accordance with the Florida Building Code.
- 4. Administrative Submittal: Proposed maintenance Agreement and proposed sample warranty.

B. Shop Drawings:

- 1. Project-specific details of roof edges and penetrations.
- 2. Mechanical fastening diagram for rigid insulation, where applicable.
- 3. Layout drawings for tapered insulation, showing slopes and thicknesses.
- 4. List of materials proposed for use including roofing materials, insulation, cover board, composition flashing, and fasteners.
- 5. Description of complete system, from deck up, proposed for use.
- 6. Miami-Dade Notice of Acceptance or Florida Product Approval documentation for the proposed roofing assembly.

C. Quality Control Submittals:

- 1. Manufacturer's installation instructions and recommendations for proper maintenance of the approved roof system including inspection frequencies, penetration addition policies, temporary repair and leak call procedures.er maintenance.
- 2. Proposed maintenance agreement.
- 3. Manufacturer's Certificate of Compliance,
- 4. Written notice when roofing installation is ready for final inspection.
- 5. Record of Preroofing Conference.

- D. Contract Closeout Submittals: Special guarantee.

1.06 QUALITY ASSURANCE

- A. Materials, including insulation, used in a roofing system shall be furnished by, or approved by, manufacturer whose roofing system is selected for use.
- B. Roofer Qualifications: Approved by roofing materials manufacturer to apply roof.
- C. Product Quality Assurance Program: Primary roofing material shall be manufactured in the United States under a quality management system that is monitored under the ISO9001:2000 audit process.
- D. Roofing system shall be an Underwriter's Laboratories Class A without requirements for gravel or additional coatings.
- E. Local Regulations: Roofing system shall meet regulations of all public agencies including specific local requirements of the City of Key West.
- F. Preroofing Conference:
 - 1. Attendees: Conduct preroofing conference with Engineer, roof deck installer, roofing system materials manufacturer's representative, roof insulation manufacturer's representative, roofer, mechanical equipment installer and other subcontractors likely to be on roof.
 - 2. Agenda: Follow outline in NRCA, HARK including acceptability of deck, roofing system materials manufacturer's specification selected, flashing details, roof guarantee, and protection of finished roofing system.
 - 3. Record: Discussions and agreements and furnish copy to each participant and entity invited.

1.07 DELIVERY, STORAGE, AND HANDLING

- A. Deliver materials in manufacturer's original, unopened containers and rolls with labels intact and legible. Labels on bitumen shall show composition, softening point (SP) range, minimum flashpoint (FP), minimum finished blowing temperature (BT), and equiviscous temperature (EVT) range.
- B. Handle roll goods so as to prevent damage to edge or ends. Store roll goods on end.
- C. Store rigid roof insulation materials on clean, raised platforms.
- D. Protect materials against direct sunlight, wetting, moisture absorption, mud, dust, sand, oil, grease, dirt, and construction traffic.

1.08 ENVIRONMENTAL REQUIREMENTS

A. Temperature:

1. Apply roofing only in dry weather and when ambient temperature is above 40 degrees F.
2. When temperature is below 45 degrees F, application must be approved by, and under supervision of, roofing materials manufacturer.
3. Do not apply any roofing materials during precipitation or in the event there is a probability of precipitation.
4. Protect work in progress from moisture damage or contamination.
5. Requirements Prior to Job Start:
 - a. Give a minimum of 5 days' notice to the Owner and manufacturer prior to commencing any work.
 - b. Familiarize every member of the application crew with all fire and safety regulations recommended by OSHA and NRCA.
 - c. Complete to the Owner's satisfaction all job cleanup including removal of removed existing roofing debris, and exterior building area and landscaping affected by construction.

1.09 SPECIAL GUARANTEE

A. Product: Furnish manufacturer's extended guarantee, with Owner named as beneficiary, in writing, as special guarantee. The roof system guarantee shall cover correction of the specified tapered insulation, protection board, roof system membranes described, including flashing and membrane edge terminations under metal coping systems, found defective during a period of 20 years after the date of Substantial Completion without deductibles or limitations in coverage amount. This guarantee will be issued at no additional cost to the Owner within this Specification.

B. Coverage and Conditions:

1. Coverage shall include as a minimum the following:
 - a. All costs with no dollar limit, for repairs required to maintain roofing system, composition flashing, curb and penetration flashing and termination details in a watertight condition.
 - b. Natural deterioration of roofing system due to ordinary wear and tear by the elements.
 - c. Defects due to faulty materials or workmanship during application.
 - d. The actual resistance to heat flow through the roof insulation will be at least 80 percent of the design thermal resistance, provided the roofing membrane is free of leaks.

- e. The roof insulation will remain in a re-roofable condition should the roof membrane require replacement, excluding damage caused by fastener pullout during initial existing membrane removal.
 - f. The new coping system approved and installed is to be engineered and guaranteed under the guarantee for the life of the roof.
2. Guarantee document shall cover the roofing system with all components of the total assembly in this one document provided by the roofing manufacturer.

PART 2 PRODUCTS

2.01 SUBSTRATE

- A. Existing concrete deck.

2.02 MODIFIED BITUMEN SHEET ROOFING (SBS) ASSEMBLY/ PRODUCTS

- A. Polyisocyanurate Tapered Roof Insulation: Tapered panels and standard and standard fill panels composed of a closed cell, rigid polyisocyanurate foam core material, integrally laminated between glass fiber facers as per ASTM C1289, Type II, Class 1, Grade 2. The slope shall not be less than 1/4 inch per foot and have a minimum thickness of 1.5 inches.
 1. Manufacturers: Tapered Paratherm by Siplast.
 2. Maintain a maximum panel size of 4 feet by 4 feet for installation with adhesive.
 3. Insulation R values:
 - a. Administration Building: R-17.
 - b. Chlorine Building: R-17.
- B. Gypsum Sheathing Panel: A panel composed of a gypsum board, nonstructural water resistant core with a nominal thickness of 1/2 inch. Material: DensDeck Prime Gypsum Roof Board by Georgia Pacific.
- C. Catalyzed Acrylic Resin Flashing System: The use of this specialty flashing system shall be specifically approved in advance by the manufacturer for each application. Parapro 123 Flashing System by Siplast.
- D. Insulation Adhesive: Para-Stik Insulation Adhesive by Siplast.
- E. Bituminous Cutback Materials:
 1. Primer: An asphalt, solvent blend conforming to ASTM D41 requirements. Siplast PA-1125 Asphalt Primer.
 2. Mastics: In accordance with ASTM D4586 Type II requirements; Siplast PA-1021 plastic cement.

- F. Products, A through E above, as manufactured for use with an approved equal roof systems manufactured by Firestone or CertainTeed, which are attached to this section as Supplements, shall be as recommended for each assembly by its manufacturer.

2.03 DESCRIPTION OF ROOF MEMBRANE

- A. Roofing membrane assembly consisting of two plies of prefabricated, reinforced, homogeneous styrene-butadiene-styrene (SBS) block copolymer modified asphalt membrane, secured to a prepared substrate. Both reinforcement mats to be impregnated and coated each side with a high quality SBS bitumen blend adhesive layer. The adhesive layer shall be manufactured using a process that embosses the surface with a grooved pattern to provide optimum burn-off of the plastic film and to maximum application rates. The roof system shall pass 500 cycles of ASTM D5849, passing results to show no signs of membrane cracking or interply delamination. Roof system to pass 200 cycles of ASTM D5849 after heat aging. Roof assembly to possess waterproofing capability, such that phased roof application, with only modified bitumen base ply in-place, can be achieved for prolonged periods of time without detriment to the watertight integrity of the entire roof system.
- B. Manufacturer:
1. Siplast (Basis of design) (NOA No. 13-0514.04).
 2. Firestone (System type A19 under NOA No. 11-0119.11 or approved equal).
 3. Other manufacturers and systems approved as equal.
- C. Base Sheet: ASTM D4601, Type I, a fiberglass reinforced, asphalt coated sheet, having a minimum weight of 24 pounds/square.
1. Siplast Parabase.
- D. Modified Bitumen Base Ply:
1. ASTM D6163, Grade S, Type I, high performance modified bitumen base ply designed for use in homogeneous multilayer modified bitumen roof membrane systems. Consists of lightweight random fibrous glass mat impregnated and coated with high quality SBS modified bitumen.
 2. Siplast Paradiene 20TG.

- E. Modified Bitumen Finish Sheet:
 - 1. ASTM D6163, Grade G, Type I, high performance, modified bitumen finish sheet designed for use in homogeneous multilayer modified bitumen roof membrane systems. Consists of lightweight random fibrous glass mat impregnated and coated with high quality SBS modified bitumen, and surfaced with ceramic granules.
 - 2. Ceramic Granule Surface Color: Manufacturer's color to match existing roof color, No. 11 Grade specification.
 - 3. Equal to Siplast Paradiene 20TG/30FRTG-torchable grade.
- F. Walk Pads: Traffic resistant polymer modified bitumen sheet, polyester reinforced, surfaced with mineral granules, equal to Siplast Paratread.
- G. Composition Flashing: One of the following:
 - 1. Flashing sheet combining SBS polymer modified bitumen, glass fiber mats, and polyester core providing built-in adhesive for torch-on application as manufactured by:
 - a. Siplast; Veral Aluminum Clad.
- H. Fasteners: Into Wood Nailers: Zinc-coated, 12-gauge roofing nails with 1-inch diameter metal caps or heads and deformed shanks.
- I. Caulking/Sealants: A moisture curing, nonslump elastomeric sealant; Siplast PS-304 elastomeric sealant by Siplast.
- J. Perlite Cant Stripes: A cant strip composed of expanded volcanic minerals combined with waterproofing binders. The top surface shall be per the supplement listed below, following "End of Section," is part of this Specification (Torchable).
 - 1. Transmittal of Contractor's Submittal.
- K. Treated with an asphalt based coating. The face of the cant shall have a nominal 4-inch dimension.
- L. Metallic Powder: A finely graded metal dust as supplied or approved by the membrane manufacturer, used for covering of bitumen overruns over the foil surfaced membrane flashing.
- M. Products, A through K above, as manufactured for use with an approved equal roof systems manufactured by Firestone or CertainTeed, which are attached to this Section as Supplements, shall be as recommended for each assembly by its manufacturer.

PART 3 EXECUTION**3.01 PREPARATION**

- A. General: Sweep or vacuum all surfaces, removing all loose aggregate and foreign substances prior to commencement of roofing.
- B. Remove all Existing:
 - 1. Surface gravel.
 - 2. Existing roof membrane.
 - 3. Existing Insulation.
 - 4. Existing perimeter flashing.
 - 5. Existing water damaged curbs.
 - 6. Base flashings.
 - 7. Flanged metal flashings.
 - 8. Cants.
 - 9. Walkways.
 - 10. Nonfunctional penetrations.
 - 11. Drain assemblies.
 - 12. Vapor retarder.
 - 13. Metal trim, counter flashing.
- C. Deck shall be firm, dry, free of foreign materials, and smooth.
 - 1. Differential height between adjacent roof deck members of more than 1/8 inch is not acceptable.
 - 2. Report immediately to the Engineer cracks, breaks, holes, or other unusual irregularities in the surface.

3.02 SUBSTRATE PREPARATION

- A. Insulation: Install panels with joints offset, over existing concrete deck. Edges of panels shall be in moderate contact without forcing applied in strict accordance with the insulation manufacturer's requirements. Where insulation is installed in two or more layer, stagger joints between layers. Maintain a maximum panel size of 4 feet by 4 feet applied in insulation adhesive.

3.03 ROOF MEMBRANE APPLICATION

- A. General: Do not phase application of roofing system.
 - 1. Deck Preparation: Prime the deck surface and metal with asphalt primer at a uniform coating.
 - 2. Bitumen Consistency: cutting and alterations of bitumen, primer and sealants are not permitted.

B. Roof Membrane Installation:

1. Membrane Application: Apply roofing in accordance with roofing system manufacturer's instructions and the following requirements. Application of roofing membrane components shall immediately follow application of the base sheet as a continuous operation.
2. Aesthetic Considerations: An aesthetically pleasing overall appearance of the finished roof application is a standard requirement for this Project. Make necessary preparations, utilize recommended application techniques, apply the specified materials (i.e., granules, metallic powder, etc.), and exercise care in ensuring that the finished application is acceptable to the Owner.
3. Priming: Prime metal flanges (all jacks, edge metal, lead drain flashings, etc.) and concrete and masonry surfaces with a uniform coating of ASTM D41 asphalt primer.
4. Membrane Torched Application: Torched in a smooth, even, continuous layer without breaks or voids.
5. Bitumen Consistency: Cutting or alterations of bitumen, primer, and sealants will not be permitted.
6. Roofing Application: Apply all layers of roofing free of wrinkles, creases, or fishmouths. Exert sufficient pressure on the roll during application to ensure prevention of air pockets. Stagger the lap seams between the base ply layer and the finish ply layer. Stagger the courses to ensure this.
 - a. Apply all layers of roofing perpendicular to the slope of the insulation.
 - b. Fully bond the base ply to the prepared substrate, utilizing minimum 3-inch side and end laps. Apply each sheet directly behind the torch applicator. Cut a dog ear angle at the end laps on overlapping selvage edges. Using a clean trowel, apply top pressure to top seal T-laps immediately following sheet application. Stagger end laps a minimum of 3 feet.
 - c. Fully bond the finish ply to the base ply, utilizing minimum 3-inch side and end laps. Apply each sheet directly behind the torch applicator. Stagger end laps of the finish ply a minimum of 3 feet. Cut a dog ear angle at the end laps on overlapping selvage edges. Using a clean trowel, apply top pressure to top seal T-laps immediately following sheet application. Stagger side laps of the finish ply a minimum 3 feet from side laps in the underlying base ply. Stagger end laps of the finished ply, a minimum 3 feet from end laps and the underlying base ply.
7. Granule Embedment: Broadcast mineral granules over all bitumen overruns on the finish ply surface, while the bitumen is still hot, to ensure a monolithic surface color.

8. Use of Metallic Powder: Broadcast metallic powder over all bitumen overruns on the metal foil membrane surface while the bitumen is still hot to ensure a monolithic surface color.
- C. Roof System Interface with Related Components: The following is a list of verbal descriptions for correct installation of components integrated into the roof membrane assembly. In all cases, unless otherwise approved, incorporate flanged components into the system between the application of the base ply and the finish ply. The flange must be primed with a uniform coating of approved ASTM D41 asphalt primer and allowed to dry thoroughly; all flanges must be set in approved mastic.
1. Edge Metal: Completely prime metal flanges and allow to dry prior to installation. After the base ply and continuous cleat (if applicable) have been installed, set the flange in mastic and stagger nail every 3 inches on center. Strip-in the flange using the stripping-ply material, extending a minimum of 4 inches beyond the edge of the flange. Terminate the finish ply at the top of the parapet wall across the blocking under metal coping. See paragraph Sealant below for finish of this detail.
 2. Lead Drain Flashings: Completely prime the lead drain flashing and allow to dry prior to installation. After the base ply has been applied, set the lead flashing sheet in mastic and form to turn down inside of the drain bowl. Ply-in the perimeter of the lead flashing using an additional layer of the base ply material, overlapping the perimeter of the lead a minimum of 4 inches. Terminate the finish ply to extend beneath the clamping ring seal. Install the clamping ring with all clamps, bolts, etc. in-place.
 3. Small Pipe Supports: Support all gas lines and conduits which are a maximum of 1-inch diameter and run horizontally over the roof membrane surface using wood blocking and the manufacturer's walktread-roof protection material. The blocking shall be 4 inches by 4 inches by 12 inches in size. Cut each walk tread pad to a size which extends a minimum of 2 inches beyond the perimeter of the blocking. Loosely secure the pipe to allow movement over the 6-inch center of each block; the spacing for the blocks shall be of adequate distance to prevent sagging of the pipe and to prevent the pipe from coming into contact with the new roof assembly. Set the walk tread dry over the new roof assembly. Set each pipe support block dry over the walktread pad.
 4. Sealant: Caulk all exposed finish ply edges at gravel stops, waste stacks, pitch pans, vent stacks, etc., with a smooth continuous bead of approved sealant.

5. Flashing Application: Masonry Surfaces: Flash masonry parapet walls and curbs using reinforcing sheet and the metal foil flashing membrane. After the base ply has been applied to the top of the cant, fully adhere the reinforcing sheet, utilizing minimum 3-inch side laps and extend a minimum of 3 inches onto the base ply surfaces and at least 3 inches up the parapet wall above the cant. After the final roofing ply has been installed to the top of the cant, prepare the surface area that is to receive flashing coverage by torch heating granular surfaces or by application of asphalt primer; allowing primer to dry thoroughly. Torch apply the metal foil-faced flashing in to place using 3-foot widths always lapping the factory salvage edge. Stagger the laps of the metal foil flashing layer from lap seams in the reinforcing layer. Extend the flashing sheet a minimum of 4 inches beyond the toe of the cant onto the prepared surface of the finished roof and up the wall to the desired flashing height. Nail the top of the edge of the flashing on 9-inch centers.
6. Flashing Application Surfaces Sheathed with Gypsum Sheathing Panels: After the gypsum sheathing panel and cant backing sheet have been installed, flash parapet walls and curb with the specified reinforcing sheet and the metal foil flashing membrane. The reinforcing sheet shall have a minimum of 3-inch side laps and extend a minimum of 3 inches onto the base ply surface and to the top of the parapet wall or curb. Using the fasteners as specified by the manufacturer, mechanically attach the reinforcing sheet through the field of the sheet to the vertical flashing surface on 12-inch centers from the top of the cant to the top of the wall or curb. Using a Leister hand welding tool, seal the laps between flashing reinforcing sheets. After the final roofing ply has been applied to the top of the cant, prepare surface area that is to receive flashing coverage by torch heating granular surfaces or by application of asphalt primer; allowing the primer to dry thoroughly. Torch apply the metal foil-faced flashing into place using 3-foot widths always lapping the factory selvage edge. Extend the flashings a minimum of 4 inches beyond the toe of the cant onto the prepared surface of the finished roof and up the wall to the desired flashing height. Exert pressure on the flashing sheet during application to ensure complete contact with the wall/roof surfaces, preventing air pockets. Check and seal all edges and laps for tight seal.

D. Walk Pad Installation:

1. Cut the walk tread into maximum 5-foot lengths and allow to relax until flat. Adhere the sheet using the specified plastic cement. Apply the specified cement in a 3/8-inch thickness to the back of the product in 5-inch by 5-inch spots in accordance to manufacturer directions. Position pads a minimum of 2 inches from each other to allow for proper drainage.
2. Adhere to clean and dry roof membrane surfaces with roofing cement as recommended by roofing manufacturer.
3. Apply pads in pattern as indicated on Drawings.

- E. Manufacturers' installation requirements and specifications for required warranties for an equal roof assembly manufactured by Firestone or CertainTeed are to be followed.

3.04 FIELD QUALITY CONTROL

A. Concrete Deck Dryness Test:

1. Test for dryness before applying insulation.
2. Should rain occur during application, retest for dryness before continuing roof application.
3. Perform the Following Tests for Dryness:
 - a. Foaming:
 - 1) Heat one pint of specified bitumen to 350 to 400 degrees F.
 - 2) Pour on surface to receive insulation.
 - 3) If bitumen foams, deck is not dry enough to roof.
 - b. Strippability:
 - 1) Cool bitumen poured on deck to ambient temperature.
 - 2) Strip from surface.
 - 3) If any portion strips clean from deck or insulation, surface is not dry enough to roof.

3.05 MANUFACTURER'S FIELD SERVICES

- A. Provide manufacturer's representative at Site for prerooting conference and as requested by Owner during installation, for installation assistance, inspection and certification of proper installation, roof testing.
- B. Notify the manufacturer for final inspection and manufacturer to provide endorsement of guarantee to the Owner upon final inspection.

3.06 CLEANING

A. Upon Completion of the Roofing Installation:

1. Cleanup waste material and debris resulting from roofing operation.
2. Dispose of waste material off the site.
3. Remove spots and smears of asphalt or other material from flashings, gravel stops, and other surfaces not intended to be coated with such material.
4. During removal, ensure that no damage will be done to the surfaces.
5. Use solvents, if necessary, to satisfactorily clean the materials.

END OF SECTION

SECTION 07 62 00
SHEET METAL FLASHING

PART 1 GENERAL

1.01 REFERENCES

- A. The following is a list of standards which may be referenced in this section:
1. ASTM International (ASTM):
 - a. A153/A153M, Standard Specification for Zinc Coating (Hot-Dip) on Iron and Steel Hardware.
 - b. A653/A653M, Standard Specification for Steel Sheet, Zinc-Coated (Galvanized) or Zinc-Iron Alloy-Coated (Galvannealed) by the Hot-Dip Process.
 - c. A666, Standard Specification for Annealed or Cold-Worked Austenitic Stainless Steel Sheet, Strip, and Flat Bar.
 - d. A924/A924M Standard Specification for General Requirements for Steel Sheet, Metallic-Coated by the Hot-Dip Process.
 - e. B32, Standard Specification for Solder Metal.
 - f. B209, Standard Specification for Aluminum and Aluminum-Alloy Sheet and Plate.
 - g. B370, Standard Specification for Copper Sheet and Strip for Building Construction.
 - h. C920, Standard Specification for Elastomeric Joint Sealants.
 - i. C1311, Standard Specification for Solvent Release Sealants.
 - j. D1187, Standard Specification for Asphalt-Base Emulsions for Use as Protective Coatings for Metal.
 - k. D4586, Standard Specification for Asphalt Roof Cement, Asbestos-Free.
 2. Federal Specifications (FS): QQ-L-201F(2), Lead Sheet.
 3. Sheet Metal and Air Conditioning Contractors National Association (SMACNA): Architectural Sheet Metal Manual, 5th Edition. Structural designed assumed:
 - a. Wind Speed: 150 mph Code Required. However, flashing items covered in this Section shall meet all the requirements of the FMI-225 roof assembly to be installed per Section 07 52 17, Modified Bitumen Sheet Roofing Over Concrete Substrate.
 - b. Exposure: C.
 - c. Importance Factor: 1.15.

1.02 PERFORMANCE REQUIREMENTS

- A. General: Sheet metal flashing and trim shall withstand wind loads, structural movement, thermally induced movement, and exposure to weather without failing, rattling, leaking, and fastener disengagement.
- B. Wind Load (3-Second Gust): 200 mph; design to meet minimum developed uplift resistance of roofing system.
- C. Thermal Movements:
 - 1. Provide sheet metal flashing and trim that allows for thermal movements resulting from the following maximum change (range) in ambient and surface temperatures by preventing buckling, opening of joints, hole elongation, overstressing of components, failure of joint sealants, failure of connections, and other detrimental effects.
 - 2. Provide clips that resist rotation and avoid shear stress as a result of sheet metal and trim thermal movements.
 - 3. Base engineering calculation on surface temperatures of materials due to both solar heat gain and nighttime-sky heat loss.
- D. Water Infiltration: Provide sheet metal flashing and trim that does not allow water infiltration to building interior.

1.03 QUALITY ASSURANCE

- A. Sheet Metal Flashing and Trim Standard: Comply with SMACNA's "Architectural Sheet Metal Manual." Conform to dimensions and profiles shown, unless more stringent requirements are indicated.

1.04 SUBMITTALS

- A. Action Submittals:
 - 1. Shop Drawings:
 - a. Show joints, types and location of fasteners, and special shapes.
 - b. Catalog data for stock manufactured items.
 - c. Submit all details which are proposed to be used and which are recommended construction details of the proposed manufacturer. All details will show specification of all materials to be used.
 - 2. Samples: Color samples for items to be factory finished.

1.05 DELIVERY, HANDLING, AND STORAGE

- A. Inspect for damage, dampness, and wet storage stains upon delivery to Work Site.

- B. Remove and replace damaged or permanently stained materials that cannot be restored to like-new condition.
- C. Carefully handle to avoid damage to surfaces, edges, and ends.
- D. Do not open packages until ready for use.
- E. Store materials in dry, weathertight, ventilated areas until immediately before installation.

1.06 SPECIAL GUARANTEE

- A. Product: Furnish manufacturer's extended guarantee or warranty, with Owner named as beneficiary, in writing, as Special Guarantee. Special Guarantee shall provide for correction or, at the option of the Owner, removal and replacement of factory-applied fluoropolymer coating, finish, and accessories found defective during a period of 20 years after date of Substantial Completion. Duties and obligations for correction or removal and replacement of defective Work shall be as specified in General Conditions.
- B. Conditions:
 - 1. Finish: No cracking, blistering, flaking, chipping, checking, chalking, peeling, or fading.
 - 2. All Components: Watertight and weathertight with normal usage.

PART 2 PRODUCTS

2.01 METAL

- A. Prefinished Aluminum Sheet: ASTM B209, alloy and temper as required for application and finish: 0.032-inch thick; stucco embossed finish; shop precoated with fluoropolymer coating (Kynar polyvinylidene fluoride resin) coating; color as selected from manufacturer's standard color range.
- B. Lead Sheet: Federal Specification QQ-L-201F(2), Grade B solid lead, minimum weight 4 pounds per square foot, soft temper, except hard temper for flanges.
- C. Stainless Steel: ASTM A666, Type 304 or Type 316, soft temper; thickness and finish, as shown.
- D. Copper: ASTM B370, Temper Designation Standard H00, cold-rolled 1/8 hard, 16 ounces per square foot.

2.02 REGLETS AND COUNTERFLASHING

A. For Concrete:

1. Stainless steel, 0.015 inch.
2. Manufacturers and Products:
 - a. Fry Reglet Corp.; Fry Springlok Type CO and Springlok Flashing.
 - b. Cheney Flashing Co.; Type A reglet and Snap Lock Cap Flashing.

2.03 PREFABRICATED METAL SYSTEMS

A. Coping System:

1. Any coping system proposed for this Project will require a third party testing submittal proving that proposed installation will resist developed positive and negative pressures. System will be Snap-on system, stucco embossed pattern aluminum, 0.050-inch minimum thickness. Factory finish color of coping is to match color of building walls.
2. Include ancillary items, such as mitered and welded corners, and end caps, where shown and as required for complete system.
3. Manufacturers and Products:
 - a. Firestone Snap-on Coping
 - b. Siplast, Paraguard Coping. See Section 07 52 17, Modified Bitumen Sheet Roofing over Concrete Substrate.

- B. Finish: Factory finished with full strength fluoropolymer coating (Kynar polyvinylidene fluoride resin) in color as selected by Engineer.

2.04 ANCILLARY MATERIALS

- A. Solder: ASTM B32, alloy composition Sn 50 and Sn 60 for stainless steel.
- B. Soldering Flux: ASTM B32, Type RA.
- C. Burning Rod for Lead: Same composition as lead sheet.
- D. Sealing Tape: Polyisobutylene sealing tape specifically manufactured for setting flanges on bituminous roofing.
- E. Isolation Paint: ASTM D1187, asphalt.
- F. Isolation Tape: Butyl or polyisobutylene, internally reinforced, or 20-mil thick minimum polyester.
- G. Plastic Roof Cement: ASTM D4586, Type II.

- H. Elastomeric Sealant: ASTM C920, elastomeric silicone polymer sealant; of type, grade, class, and use classifications required to seal joints in sheet metal flashing and trim and remain watertight.
- I. Butyl Sealant: ASTM C1311, single-component, solvent-release butyl rubber sealant, polyisobutylene plasticized, heavy bodied for hooked-type expansion joints with limited movement.
- J. Fasteners:
 - 1. For Zinc or Aluminum Work: Stainless steel or aluminum.
 - 2. For Stainless Steelwork: Stainless steel.
 - 3. For Copperwork: Copper or copper alloy.
 - 4. Nails: Roofing nailhead, 10-gauge spiral or ring shank, lengths as required to penetrate wood at least 3/4-inch or as required in Article Performance Requirements.

2.05 FABRICATION OF FLASHING

- A. Field measure prior to fabrication.
- B. Fabricate in accordance with SMACNA Architectural Sheet Metal Manual that apply to design, dimensions, metal, and other characteristics of item indicated.
- C. Pipe Penetrations through Roof: Flash with lead as shown on Drawings.
- D. Conceal fasteners and expansion provisions where possible on exposed-to-view sheet metal flashing and trim, unless otherwise indicated.
- E. Fabricate cleats and attachment devices from same material as accessory being anchored or from compatible, noncorrosive metal.
 - 1. Thickness: As recommended by SMACNA's "Architectural Sheet Metal Manual" and FMG Loss Prevention Data Sheet 1-49 for application, but not less than thickness of metal being secured.

PART 3 EXECUTION

3.01 EXAMINATION

- A. Verify roof openings, curbs, pipes, sleeves, ducts, or vents through roof are solidly set, and cant strips and reglets in-place.
- B. Verify nailing strips and blocking are properly located.

- C. Verify membrane termination and base flashings are in-place, sealed, and secure.

3.02 INSTALLATION

A. Flashing:

1. General: Install sheet metal roof flashing and trim to comply with performance requirements and SMACNA's "Architectural Sheet Metal Manual." Provide concealed fasteners where possible, set units true to line, and level as indicated. Install work with laps, joints, and seams that will be permanently watertight.
2. Roof Edge Flashing: Anchor to resist uplift and outward forces according to recommendations in FMG Loss Prevention Data Sheet 1-49 for specified wind zone and as indicated.
 - a. Interlock bottom edge of roof edge flashing with continuous cleats anchored to substrate at 16-inch centers.
3. Isolate metal from wood and concrete and from dissimilar metal with isolation tape or two coats of isolation paint.
4. Use only stainless steel fasteners to connect isolated dissimilar metals.
5. Joints: 10-foot maximum spacing and 2-1/2 feet from corners, butted with 3/16-inch space centered over matching 8-inch-long backing plate with sealing tape in laps.
6. Set flanges of flashings and roof accessories on continuous sealer tape or in plastic roof cement on top of envelope ply of roofing. Nail flanges through sealing tape and at 3-inch maximum spacing. Touchup isolation paint on flanges.
7. Joints, Fastenings, Reinforcements, and Supports: Sized and located as required to preclude distortion or displacement due to thermal expansion and contraction.
8. Provide continuous holddown clips at counterflashing and gravel stops.
9. Conceal fastenings wherever possible.
10. Set flashing and sheet metal to straight, true lines with exposed faces aligned in proper plane without bulges or waves.
11. At vents through roof turn down lead flashing minimum 2 inches inside vent pipe.

B. Prefabricated Metal Systems:

1. Follow system manufacturer's printed instructions.
2. Place color variations in pieces so no extremes are next to each other.

3.03 FINISH

- A. Exposed Surfaces of Flashing and Sheet Metalwork: Free of dents, scratches, abrasions, or other visible defects, and clean and ready for painting where applicable.

3.04 CLEANING AND PROTECTION

- A. Clean exposed metal surfaces of substances that interfere with uniform oxidation and weathering.
- B. Clean and neutralize flux materials. Clean off excess solder and sealants.
- C. Remove temporary protective coverings and strippable films as sheet metal flashing and trim are installed. On completion of installation, clean finished surfaces, including removing unused fasteners, metal filings, pop rivet stems, and pieces of flashing. Maintain in a clean condition during construction.
- D. Replace sheet metal flashing and trim that have been damaged or that have deteriorated beyond successful repair by finish touchup or similar minor repair procedures.

END OF SECTION

SECTION 07 70 01
ROOF SPECIALTIES AND ACCESSORIES

PART 1 GENERAL

1.01 REFERENCES

- A. The following is a list of standards which may be referenced in this section:
1. Air Movement and Control Association International (AMCA).
 2. American Architectural Manufacturers Association (AAMA).
 3. ASTM International (ASTM):
 - a. D1187, Standard Specification for Asphalt-Base Emulsions for Use as Protective Coatings for Metal.
 - b. D4586, Standard Specification for Asphalt Roof Cement, Asbestos-Free.
 4. FM (Factory Mutual) Global (FMG).
 5. Underwriters Laboratories Inc. (UL).

1.02 SUBMITTALS

- A. Action Submittals:
1. Shop Drawings of each item specified showing materials, details, flashing, anchorage, and relation to adjacent structure.
 2. Catalog cuts of each item specified item.

1.03 SEQUENCING AND SCHEDULING

- A. Coordination: Schedule and coordinate Work of this section with Work of Section 07 52 17, Modified Bitumen Sheet Roofing, over concrete substrate and Section 07 62 00, Sheet Metal Flashing.

PART 2 PRODUCTS

2.01 ROOF EQUIPMENT CURBS

- A. Prefabricated Galvanized Steel: Minimum 12-inch high curb with treated wood nailer, liner panel, and factory installed insulation as required for conditions shown on Drawings.
- B. Metal Gauge and Reinforcement: To suit imposed loads of equipment to be supported.

C. Fabricate curbs to fit roof slope.

D. Manufacturers and Products:

1. Pate Co.; PC-2.
2. Thy Curb; Model TC-3.
3. RPS Corporation; RC-2A.

2.02 PIPE CURBS FOR VENT STACKS

A. Existing pipe vent to be measured for outside diameter and model number for assembly will be adjusted accordingly.

B. Pipe curb assembly will include galvanized steel roof curb, unitized construction, with integral base plate, 1-1/2 inch insulation and 2 by 2 treated wood nailer. Unit shall be furnished with acrylic clad thermoplastic cover, fastening screws, and graduated step boots with stainless steel clamps.

C. Manufacturer and Products:

1. Pate Co.; PCC-4, Curb PCA-5 and Graduated step boot b-12.
2. Approved equal.

2.03 PIPE SEALS

A. Prefabricated one-piece aluminum flanged base with stepped, graduated EPDM cap and adjustable stainless steel clamps.

B. Manufacturers and Products:

1. Pate Co.; Pipe Seal.
2. Portals Plus, Inc.; Alumi-Flash.

2.04 COMBINATION ROOF DRAINS

A. Existing diameter drain lines, existing diameter of drain inlet head and distance between the Primary and Emergency Overflow drains are to be field verified for new drain supply and installation at each location.

B. A combination roof drain assembly with aluminum dome, extension collar, sump receiver, under deck clamp, and bearing pan is preferred emergency overflow inlet must be 2 inches higher than primary drain.

- C. Manufacturer:
 - 1. Zurn Industries: Select Combination drain model number sized to match existing drain lines and drain diameter such as: Z 164, Z165, Z163, etc.
 - 2. Portals Plus: Select aluminum reroof drains sized to match each existing drain line, drain diameter and use common sump pan area.
- D. Two individual drain units can be provided installed as long as the two drains share a common sump area and the overflow drain inlet is two inches higher than primary head common sump surface.

2.05 GRAVITY EXHAUST

- A. Gravity Intake and Relief Hood or Exhaust Gooseneck:
 - 1. Aluminum, Kynar finish. Color to be selected by Engineer.
 - 2. Rectangular assembly suitable for curb mounting.
 - 3. 12-inch high self-flashing extruded aluminum roof curb.
 - 4. 1/2-inch mesh aluminum bird screen.
 - 5. Size as shown.
 - 6. Profile and size to match existing.

2.06 ANCILLARY MATERIALS

- A. Sealer Tape: Polyisobutylene sealer tape specifically manufactured for setting flanges on bituminous roofing in coordination with roof manufacturer.
- B. Isolation Paint: ASTM D1187, asphalt.
- C. Isolation Tape: Butyl or polyisobutylene, internally reinforced, or 20-mil thick minimum polyester.
- D. Plastic Roof Cement: ASTM D4586, Type II.
- E. Fasteners: Stainless steel of type required.

PART 3 EXECUTION

3.01 PREPARATION

- A. Examine surfaces and structures to receive the Work of this section.
- B. Take measurements at Site and fabricate work to suit. No changes shall be made in supporting structure to accommodate this Work.

3.02 INSTALLATION

A. General:

1. Install roof specialties and accessories as detailed in approved shop drawings and in conformance with manufacturer's instructions, recommendations, and standards.
2. Use appropriate pipe curb assembly, pipe seal, or vent pipe flashing where pipe, conduit, or cable, etc., penetrate roofing membrane.
3. Factory Finished Units: Place color variations in pieces so no extremes are next to each other.
4. Make Work weathertight and free of expansion and contraction noise.
5. Maintain separation between aluminum surfaces and concrete or dissimilar metals with isolation paint or isolation tape.
6. Hurricane holddown straps to be installed on all new and existing curbs.

END OF SECTION

SECTION 26 41 00
FACILITY LIGHTNING PROTECTION

PART 1 GENERAL

1.01 REFERENCES

A. The following is a list of standards which may be referenced in this section:

1. Lightning Protection Institute (LPI): 175, Standard of Practice.
2. National Fire Protection Association (NFPA):
 - a. 70, National Electrical Code (NEC).
 - b. 780, Standard for the Installation of Lightning Protection Systems.
3. Underwriters Laboratories, Inc. (UL):
 - a. 96, Standard for Lightning Protection Components.
 - b. 96A, Standard for Installation Requirements for Lightning Protection Systems.

1.02 DESIGN REQUIREMENTS

A. Provide lightning protection system design for the following structures:

1. Administration Building.
2. Chlorine Building.

B. Design lightning protection system to comply with all applicable provisions of LPI 175, UL 96, UL 96A, and NFPA 780.

1.03 SUBMITTALS

A. Action Submittals:

1. Drawings:
 - a. Lightning protection system layout.
 - b. Component locations.
 - c. Detailed plans.
2. Down conductor.
3. Connecting conductor.
4. Bond strap.
5. Air terminals.
6. Fittings.
7. Connectors.
8. Ground rods.

B. Informational Submittals:

1. Field test report.
2. Ground Witness Certification-Form LPI-175A.
3. Post-Installation Certification-Form LPI-175B.
4. UL 96 Master Label "C" Certification.

1.04 QUALITY ASSURANCE

- A. Designer: Lightning protection system design shall be prepared by an LPI-certified designer or recognized lightning protection manufacturer.
- B. System components shall be the product of a manufacturer regularly engaged in the manufacturing of lightning protection components in accordance with UL 96.
- C. Lightning protection system shall be installed under direct supervision of an LPI 175 Certified Master Installer.
- D. Inspection of final installation and grounding connection shall be performed by an LPI-certified inspector.
- E. Provide the Work in accordance with NFPA 70. Where required by authority having jurisdiction (AHJ), material and equipment shall be labeled or listed by a nationally recognized testing laboratory or other organization acceptable to the AHJ in order to provide a basis for approval under NEC.
- F. Materials and equipment manufactured within the scope of standards published by Underwriters Laboratories, Inc. shall conform to those standards and shall have an applied UL listing mark.

PART 2 PRODUCTS

2.01 MANUFACTURERS

- A. Materials, equipment, and accessories specified in this section shall be products of:
 1. Thompson Lightning.
 2. IPC Protection.
 3. Erico Eritech Lightning Protection Systems.
 4. VFC, Inc.
- B. No "or-equal" or substitute products will be considered.

2.02 GENERAL

- A. Complete system shall bear UL 96 Master Label C.
- B. System Material: Aluminum, unless otherwise specified.
- C. Material shall comply in weight, size, and composition for the class of structure to be protected as established by NFPA 780.

2.03 COMPONENTS

- A. Air Terminal:
 - 1. Material: Solid aluminum with tapered or blunt points as required for application.
 - 2. Diameter: 1/2 inch.
 - 3. Length: Sufficient to extend minimum 10 inches above object being protected.
 - 4. UL 96 Label B applied to each terminal.
- B. Conductors:
 - 1. Lightning System Conductors: Bare medium hard-drawn stranded copper, or stranded aluminum as required for the application.
 - 2. Main Down Conductor: Smooth twist stranding Class I.
 - 3. Connecting Conductor: Concentric stranding Class I.
 - 4. Bonding Conductor: Flexible strap, minimum 3/4-inch wide by 1/8-inch thick.
 - 5. Main down and connecting conductors shall bear the UL 96 Label A, applied every 10 feet.
 - 6. Grounding Conductors: Stranded bare copper.
- C. Cable Fastener and Accessories: Capable of withstanding minimum pull of 100 pounds.
- D. Fittings:
 - 1. Heavy-duty.
 - 2. Bolts, Screws, and Related Hardware: Stainless steel.
- E. Ground Rods:
 - 1. Material: Copper-clad.
 - 2. Diameter: 5/8 inch.
 - 3. Length: 20 feet.

F. Grounding Connections:

1. Welds: Exothermic process.
2. Fasteners: Bolted clamp type, corrosion-resistant copper alloy.
3. Hardware: Silicone bronze.

G. Cable Connections and Splicers:

1. Welds: Exothermic process.
2. Fasteners: Bolted clamp type, corrosion-resistant copper alloy.
3. Through-Roof Connectors: Straight or right angle with bronze and lead seal flashing washer.

PART 3 EXECUTION

3.01 GENERAL

- A. Workmanship to comply with all applicable provisions of LPI 175, UL 96, UL 96A, and NFPA 780.
- B. Aluminum materials shall be used where required to meet the galvanic corrosion requirements of UL 96A.
- C. Provide pitchpockets or method compatible with roofing to waterproof roof penetrations.
- D. Install system in inconspicuous manner so components blend with building aesthetics.

3.02 EXAMINATION

- A. Verify conditions prior to installation. Actual conditions may require adjustments in air terminal and ground rod locations.

3.03 INSTALLATION

A. Air Terminals:

1. Supports: Brackets or braces.
2. Parapet Bracket Attachment: Lag or expansion bolts.
3. Secure base to roof surface with adhesive or pitch compatible with roofing bond.
4. Provide terminal flashing at roof penetrations.
5. Perimeter Terminals:
 - a. Maximum Spacing: 20 feet.
 - b. Maximum Distance From Outside Edge of Building: 2 feet.
6. Roof Ridge Terminals: Maximum spacing 20 feet.

7. Mid-Roof Terminals: Maximum spacing 50 feet.
 8. Provide blunt point air terminals for applications exposed to personnel.
- B. Conductors:
1. Conceal whenever practical.
 2. Provide 1-inch PVC conduit in building walls or columns for main downloads and roof risers.
 3. Support: Maximum spacing for exposed conductors.
 - a. Vertical: 3 foot.
 - b. Horizontal: 4 foot.
 4. Maintain horizontal and vertical conductor courses free from dips or pockets.
 5. Bends: Maximum 90 degrees, with minimum 8-inch radius.
 6. Install air terminal conductors on the structural roof surface before roofing composition is applied.
- C. Bonding:
1. Bond to Main Conductor System:
 - a. Roof mounted ventilators, fans, air handlers, masts, flues, cooling towers, handrails, and other sizeable metal objects.
 - b. Roof flashing, gravel stops, insulation vents, ridge vents, roof drains, soil pipe vents, and other small metal objects if located within 6 feet of main conductors or another grounded object.
 2. Bond each steel column or major framing members to grounding system.
 3. Bond each main down conductor to grounding system.
- D. Grounding System:
1. Grounding Conductor:
 - a. Completely encircle building structure.
 - b. Bury minimum 1 foot below finished grade.
 - c. Minimum 2 feet from foundation walls.
 2. Interconnect ground rods by direct-buried copper cables.
 3. Maximum Resistance: 3 ohms when connected to ground rods.
 4. Connections:
 - a. Install ground cables continuous between connections.
 - b. Exothermic welded connections to ground rods, cable trays, structural steel, handrails, and buried and nonaccessible connections.
 - c. Provide bolted clamp type mechanical connectors for all exposed secondary connections.
 - d. Use bolted offset parapet bases or through-roof concealed base assemblies for air terminal connections.

- e. Provide interconnections with electrical and telephone systems and all underground metal pipes.
- f. Provide electric service arrestor ground wire to building water main.

3.04 FIELD QUALITY CONTROL

A. Field Testing:

- 1. Isolate lightning protection system from other ground conditions while performing tests.
- 2. Resistance: Test ground resistance of grounding system by the fall-of-potential method.
 - a. Test Resistance to Ground: Maximum 3 ohms.
 - b. Install additional ground rods as required to obtain maximum allowable resistance.
- 3. Test Report:
 - a. Description of equipment tested.
 - b. Description of test.
 - c. Test results.
 - d. Conclusions and recommendations.
 - e. Appendix, including appropriate test forms.
 - f. Identification of test equipment used.
 - g. Signature of responsible test organization authority.

END OF SECTION

PART 4

DRAWINGS

CONTRACT DOCUMENTS
for the construction of the

REPAIR OF THE ADMINISTRATION BUILDING ROOF AT THE RICHARD A. HEYMAN ENVIRONMENTAL PROTECTION FACILITY

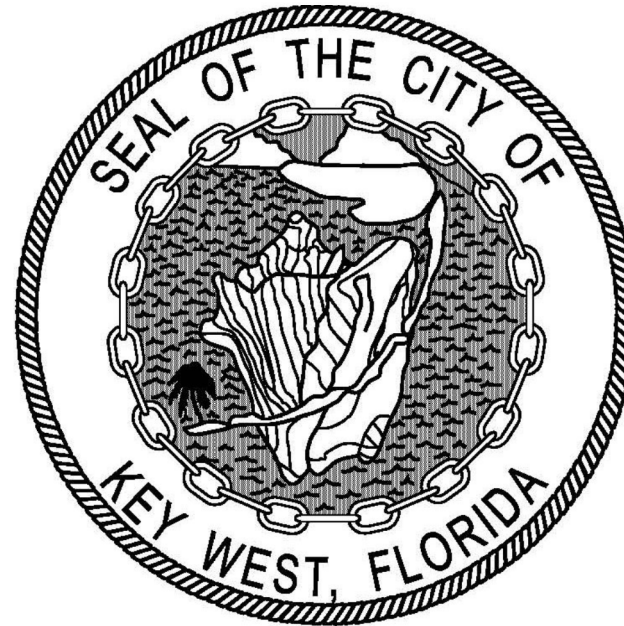

Prepared for the
City of Key West
Key West, Florida
Drawings

INDEX

- G-0 COVER SHEET AND INDEX
- A-1 CODE INFORMATION, LOCATION MAP AND GENERAL NOTES
- A-2 ROOF PLAN SOLIDS BUILDING
- A-3 ROOF PLAN OPERATIONS BUILDING
- A-4 ROOF DETAILS
- A-5 ROOF DETAILS

For information regarding
this project, contact:

ANDREW SMYTH, P.E.
6410 5th Street, Suite 2-A
Key West, FL 33040
305-294-1645

CH2MHILL

EB0000072 AAC001992

CH2M Hill Project No. 650974
AUGUST 2015
KEY WEST PROJECT No. SE1402
ITB # 15-018

BID DOCUMENTS

APPLICABLE CODES:

- 2010 FLORIDA BUILDING CODE WITH 2012 CODE AND CURRENT FBC SUPPLEMENTS
- 2010 PLUMBING CODE WITH 2012 CODE AND CURRENT FBC SUPPLEMENTS
- 2010 MECHANICAL CODE WITH 2012 CODE AND CURRENT FBC SUPPLEMENTS
- 2014 NATIONAL ELECTRICAL CODE
- 2010 FLORIDA FIRE PREVENTION CODE WITH 2012 CODE AND CURRENT FBC SUPPLEMENTS

GENERAL CODE INFORMATION:

RE-ROOFING OF EXISTING BUILDING ROOFS IS DESIGNATED "ALTERATION 1" PER 2010 FLORIDA EXISTING BUILDING CODE DUE TO ADDITION OF A NEW COPING SYSTEM AND ROOF ACCESS LADDERS.

THE NEW ROOFS WILL EXCEED MINIMUM DEVELOPED PRESSURES OF THE BUILDING CODE USING WIND SPEED OF 200 MI/HOUR WIND SPEED, AND C EXPOSURE. DESIGN PRESSURE REQUIRED FOR THESE ROOFS ARE + 60 PSF/-163 PSF. THE PROPOSED ROOF ASSEMBLY WILL BE FACTORY MUTUAL I-225 WINDSTORM DESIGN.

EXISTING USE CLASSIFICATION: WASTEWATER PLANT ADMINISTRATION BUILDING
CONSTRUCTION TYPE: EXISTING APPEARS NON-COMBUSTIBLE CONSTRUCTION.
PROPOSED AREA TO RECEIVE NEW ROOF:

North Partial Upper Roof: 60'-0" x 33'-0" = 1,980 SF
59'-6" x 65'-0" = 3,868 SF

Total Upper Roof: 5,848 SF

North Lower Roof: 28'-0" x 32'-0" = 896 SF

Total Area to Receive New Roofing: 6,744 SF

PROPOSED ROOF ASSEMBLIES: 0 HOUR NON-COMBUSTIBLE CLASS A

GENERAL NOTES: CHLORINE BUILDING ALTERNATE BID:

CHLORINE ROOF INSTALLATION IS SIMILAR TO SCOPE DESCRIBED ON THIS SHEET.

EXISTING USE CLASSIFICATION: WASTEWATER PLAN CHLORINE BUILDING
CONSTRUCTION TYPE: NON-COMBUSTIBLE CONSTRUCTION.
PROPOSED AREA TO RECEIVE NEW ROOF AND APPURTENANCES:

Chlorine Building Roof: 33'-4" x 49'-8" = 1654 SF

SEE SPECIFIC NOTES ON ALTERNATE ROOF PLAN.. DRAWING A-3.

PROJECT HISTORY:

REROOF PARTIAL EXISTING OPERATIONS BUILDING ROOF:

IN 2002, HURRICANE DAMAGE TO THIS BUILDING REQUIRED THAT TWO PORTIONS OF ROOF BE REMOVED AND REPLACED THAT HAD RECEIVED THE WORST DAMAGE. NOW THE CITY OF KEY WEST WISHES TO COMPLETE THE REROOFING OF THE REST OF THE BUILDINGS WHICH WILL COMPRISE OF TWO ADDITIONAL ROOFS AT DIFFERENT ELEVATIONS.

DEMOLITION:

1. REMOVE THE EXISTING BITUMEN ROOFING SYSTEM INCLUDING TAPERED INSULATION, TERMINATION BARS, ANY PROTECTION BOARD, FELTS, BALLAST, FLASHING, METAL REGLETS, AND CRICKETS DOWN TO CONCRETE SUBSTRATE. REMOVE ALL DEBRIS FROM THE ROOF AND DISPOSE OF IT IN COORDINATION WITH OWNER.
2. NOTIFY OWNER/OPERATOR THAT ROOF HAS BEEN REMOVED SO THAT OWNER'S REPRESENTATIVE MAY EXAMINE CONDITION OF CONCRETE SUBSTRATE PRIOR TO REROOFING.
3. REMOVE LOOSE SPALLED OR SHEARED CONCRETE OF THE EXISTING CONCRETE PARAPET AND PREPARE FOR REPAIR.
4. REMOVE EXISTING LIGHTENING PROTECTION SYSTEM, RODS AND WIRING FROM THE ROOFS AND PARAPETS.
5. REMOVE ROOF DRAINS STRAINERS AND INLET ASSEMBLIES DOWN TO CONCRETE DECK. EXAMINE CONDITION OF INLET PIPING TO RECEIVE NEW CURBS AND/OR STRAINER ASSEMBLIES.
6. REMOVE ALL EQUIPMENT CURBS AND VENT AND VENT CURBS. CONTRACTOR TO VERIFY THAT EACH SEALED CURB IS NOT A HATCH REQUIRED FOR REMOVAL OF EQUIPMENT WITHIN THE BUILDING WHICH MUST BE REFURBISHED FOR USE.
6. AFTER COMPLETION OF DEMOLITION, CONTRACTOR TO EXAMINE OPENINGS IN THE ROOF WITH THE PROJECT ENGINEER OR OWNER FOR CONDITIONS THAT WOULD AFFECT REINSTALLATION OF EQUIPMENT, DRAIN LINES, ROOF DRAINS, HATCHES, ETC.
7. ROOF DRAIN SUMP AREA MUST BE PREPARED TO CORRECT EXISTING CODE VIOLATIONS UPON REINSTALLATION OF THE PRIMARY ROOF DRAIN AND EMERGENCY OVERFLOW DRAIN INLETS.
8. EXISTING ROOF LADDERS SERVING THE AREAS OF ROOF IN SCOPE ARE TO BE REMOVED INCLUDING BRACKETS, BOLTS, ETC. AND DISPOSED OF.
9. REMOVE ALL PERIMETER FLASHING ASSEMBLIES ATTACHED TO BUILDING OR PARAPET WALLS.
10. REMOVE ANY EQUIPMENT INCLUDING FAN ASSEMBLIES, STACKS, AND VENT PIPE SECTIONS IN ORDER TO REMOVE CURBS, FANS AND HATCHES TO STORE ON SITE FOR RE-INSTALLATION.
11. WEATHER READING EQUIPMENT IS TO BE REMOVED IN ENTIRETY FOR RE-INSTALLATION AFTER COMPLETION OF NEW ROOF.

REPAIR:

1. OPENINGS LEFT WITH THE REMOVAL OF UNUSED ROOF CURBS WHICH ARE SEALED AND NON-FUNCTIONAL SHALL BE CLOSED BY FILLING IN SOLID WITH CONCRETE. SEE DETAIL 9, DRAWING A-5.
2. SPALLED, CHIPPED, CRACKED PAPAPET WALLS AND TOP ARE TO BE REPAIRED AFTER REMOVAL OF LIGHTENING PROTECTION RODS AND WIRING. SEE SPECIFICATION 03 30 01 FOR PARAPET REPAIR GROUT.
3. CONTRACTOR SHALL IDENTIFY FOR REPAIR ALL CONNECTIONS BETWEEN DRAIN LINES AND INLETS WHICH DUE TO DETERIORATION, CORROSION OR OTHER CONDITIONS WILL NOT BE ABLE TO BE RECONNECTED IN A TIGHT AND WATER PROOF REINSTALLATION.
4. EXISTING TALL BRACED VENT STACK WITH GUY WIRES: THE CURB WILL BE REPLACED AND THREE GUY WIRES WILL BE RELOCATED IN LEU OF THE EXISTING, TRIANGULATED AND ANCHORED TO SUBSTRATE OF ROOF RATHER THAN TO THE EXISTING PARAPET WALL.
5. EXAMINATION OF ALL THE ROOF PENETRATIONS SHALL BE MADE WITH THE ROOF MANUFACTURER'S REPRESENTATIVE PRIOR TO THE NEW ROOF INSTALLATION AT A JOINT MEETING AT THE SITE.

NEW ROOF CONSTRUCTION:

1. A NEW ALUMINUM ENGINEERED ROOF COPING SHALL BE PROVIDED AND INSTALLED AS PART OF THIS SCOPE OF WORK. NEW COPING WILL REQUIRE A WOOD NAILER WHICH IS ANCHORED BY DRILLING AND USING EPOXY GROUTED ANCHORS AT A SPACING ESTABLISHED BY THE ROOF UPLIFT PRESSURE REQUIREMENTS. GROUT REPAIR OF CONCRETE PARAPET WALL SURFACES MAY BE REQUIRED IN INSURE A SMOOTH CONCRETE PARAPET WALL SUBSTRATE FOR INSTALLATION OF THE ROOFING.
2. THE EXISTING PRIMARY ROOF DRAIN AND EMERGENCY OVERFLOW DRAINS ARE CURRENTLY LOCATED IN A LEVEL SUMP AREA ON THE TAPERED INSULATION PROFILES OF THE EXISTING ROOF. THE CONTRACTOR WILL FOLLOW THE SAME DESIGN PHILOSOPHY IN RE-INSTALLING TAPERED INSULATION SLOPES AROUND ALL THE DRAIN INLETS. THE EMERGENCY OVERFLOW DRAINS SHALL BE REINSTALLED 3" HIGHER THAN THE PRIMARY ROOF DRAINS AT EVERY LOCATION.
3. NEW LADDERS SHALL BE INSTALLED IN THE EXISTING LOCATIONS BUT WILL BE PROVIDED WITH CAGES OR SAFETY CLIMB DEVICES REQUIRED BY OSHA REGULATIONS AND SHALL RECEIVE A DEVICE AT GROUND LEVEL TO CONTROL ACCESS TO THE LADDER.
4. THE NEW LIGHTING PROTECTION SYSTEM: CONTRACTOR TO INSTALL NEW ENGINEERED LIGHTENING PROTECTION SYSTEM. IT IS ASSUMED THAT THE NEW SYSTEMS SHALL BE ABLE TO BE POWERED AND GROUNDED USING THE EXISTING SOURCE LOCATIONS WHEN THE EXISTING SYSTEM WAS INSTALLED IN 2002.
5. REINSTALLATION OF EXISTING WEATHER EQUIPMENT ON THE ROOF PARAPETS WILL REQUIRE REINSTALLATION WHILE MAINTAINING THE POWER SOURCE ALREADY EXISTING AND NOT PENETRATING NEW COPING OR ROOF MEMBRANE ASSEMBLY.
6. HURRICANE RESISTANCE: ALL NEW MECHANICAL CURBS AND OTHER APPURTENANCES WILL REQUIRE TO BE STRAPPED DOWN TO SUBSTRATE WITH APPROPRIATE STRAPS WHICH WILL RESIST HURRICANE UPLIFT PRESSURES
7. REINSTALL A CODE COMPLIANT SUMP AREA FOR ROOF DRAINS BY USING REVISED TAPERED INSULATION PROFILE.
8. NEW REGLET FLASHING OR ROOFING TERMINATION BAR IS TO BE PROVIDED AGAINST THE EXISTING BUILDING, LOUVER CURB AND DOOR CURB ON THE LOWER ROOF MUST USE A MODIFIED CANT OR FLASHING AT THE LOUVER SILL OR DOOR SILL..
10. NEW CRICKETS ARE TO BE CONSTRUCTED AS SHOWN USING THE PROFILE OF THE TAPERED INSULATION.
11. CANT STRIP AND PERIMETER FLASHING SHALL ALL BE CONSIDERED AS PART OF A WARRANTED COMPLETE ROOFING SYSTEM.

CRICKETS REQUIRED TO DIVERT WATER AROUND CURBS ARE TO BE PART OF A COMPLETE ROOF INSTALLATION.
12. ALL STORED EQUIPMENT AND STACKS REMOVED DURING CURB REPLACEMENT SHALL BE REINSTALLED AND VERIFIED TO BE IN WORKING ORDER POST ROOF INSTALLATION.

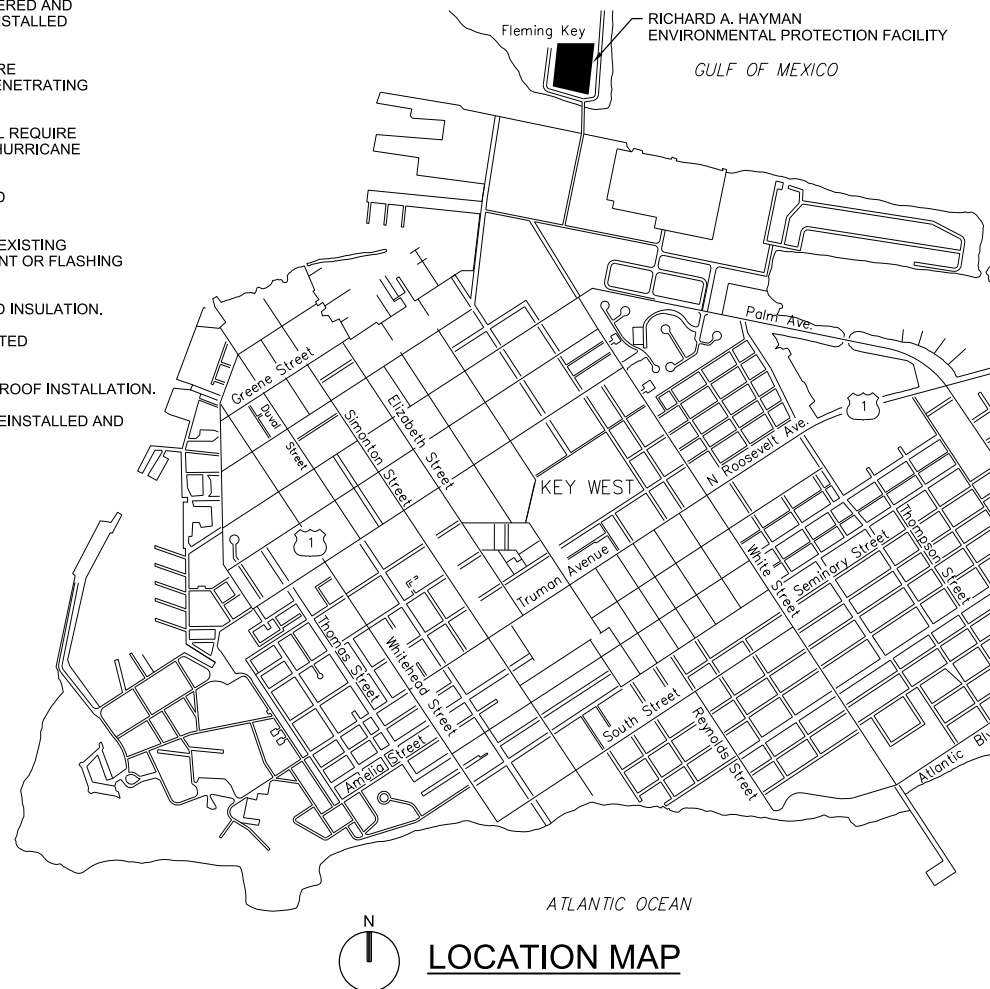

LOCATION MAP

<p>CH2MHILL®</p> <p>ARCHITECTURAL</p> <p>CODE INFORMATION</p> <p>GENERAL NOTES AND LOCATION MAP</p>	<p>ADMIN BUILDING ROOF REPLACEMENT</p> <p>KEY WEST, FLORIDA</p> <p>CITY OF KEY WEST</p> <p>RICHARD A. HAYMAN EPF</p>	<p>3011 SW WILLISTON ROAD GAINESVILLE, FLORIDA 32608 EB0000072 AAC001892</p>	<p>REUSE OF DOCUMENTS: THIS DOCUMENT, AND THE IDEAS AND DESIGNS INCORPORATED HEREIN, AS AN INSTRUMENT OF PROFESSIONAL SERVICE, IS THE PROPERTY OF CH2M HILL AND IS NOT TO BE USED, IN WHOLE OR IN PART, FOR ANY OTHER PROJECT WITHOUT THE WRITTEN AUTHORIZATION OF CH2M HILL.</p>	<p>© CH2M HILL 2015. ALL RIGHTS RESERVED.</p>
<p>VERIFY SCALE</p> <p>BAR IS ONE INCH ON ORIGINAL DRAWING.</p>		<p>DATE AUGUST 2015</p> <p>PROJ 650974</p> <p>DWG A-1</p> <p>SHEET of</p>		<p>B TRAUTWEIN</p> <p>DR</p> <p>P DENNING</p> <p>CHK</p> <p>T DODGE</p> <p>APVD</p>

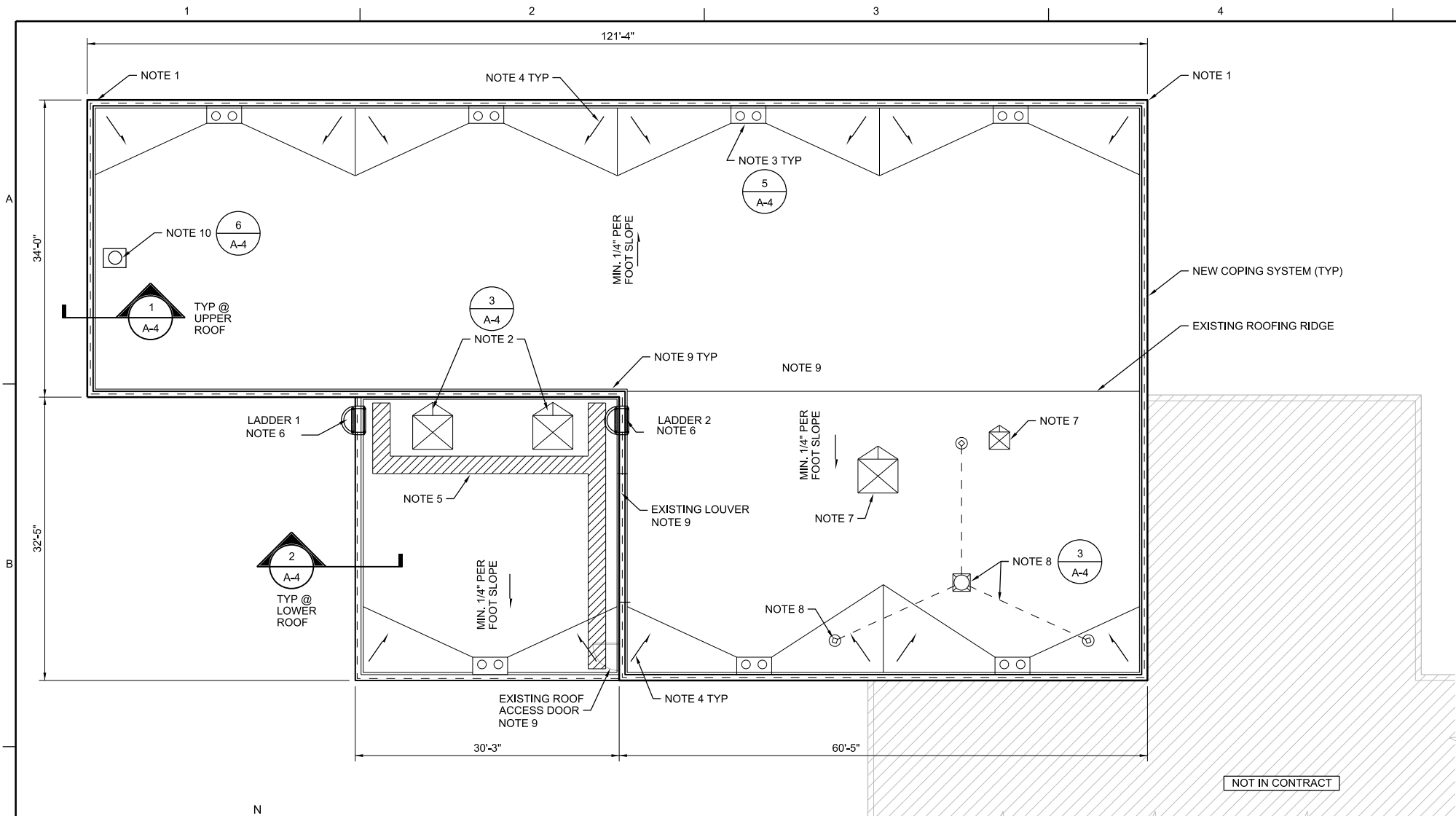

ROOF PLAN - OPERATIONS BUILDING
 1/8"=1'-0"

ROOFING NOTES:

1. TOP OF EXISTING PARAPET AT CORNERS CURRENTLY HAS WATER MEASURING AND OTHER WEATHER READING EQUIPMENT MOUNTED. THESE ITEMS ARE TO BE CAREFULLY REMOVED AND STORED AND REINSTALLED PER OWNER DIRECTION AFTER ROOFING PROJECT IS COMPLETE WITHOUT PIERCING NEW COPING OR ROOF MEMBRANE.
2. REMOVE EXISTING FAN ASSEMBLIES AND CURB TO CONCRETE SUBSTRATE. EXISTING FAN ASSEMBLIES TO BE REINSTALLED ON NEW EQUIPMENT CURBS. ALL NEW PIPE, FAN AND EQUIPMENT CURBS WILL BE ANCHORED TO ROOF SUBSTRATE ABLE TO RESIST DEVELOPED HURRICANE WIND PRESSURES. CONTRACTOR TO CONTACT ENGINEER IMMEDIATELY IF FAN ASSEMBLIES ARE IN POOR CONDITION OR CANNOT BE REINSTALLED.
3. EXISTING ROOF DRAINS:
 - A. BOTH PRIMARY DRAIN AND OVERFLOW DRAIN ASSEMBLIES ARE TO BE REMOVED DOWN TO CONCRETE SUBSTRATE. CONTRACTOR RESPONSIBLE FOR TAGGING EXISTING DRAIN LINES AS PRIMARY AND EMERGENCY DURING ROOF DEMOLITION.
 - B. PIPE CONNECTION FROM EACH DRAIN INLET IS TO BE EXAMINED FOR CORROSION OR DAMAGE THAT IMPEDES CONNECTION OF DRAIN LINES TO NEW CAGE DRAIN COVERS. NOTIFY ENGINEER IF REMOVAL OF DRAINS REVEALS INSTALLATION ISSUES.
 - C. INLET ELEVATION OF EMERGENCY OVERFLOW DRAINS TO BE A MINIMUM OF 2" HIGHER THAN PRIMARY ROOF DRAINS.
 - D. EXISTING SUMP PROFILES DO NOT MEET CODE. ROOF INSTALLER TO EITHER RE-PROFILE SUMP AREAS OF EACH DRAIN COMBINATION BY CHANGING ROOF SLOPE OR ADDING ACTUAL METAL CURB TO SET EMERGENCY DRAIN COVER HIGHER.
 - E. NEW PRIMARY ROOF DRAIN AND EMERGENCY OVERFLOW ROOF DRAIN COMBINED CURB INTEGRATED INTO LEVEL SUMP AREA (TYP).
4. ROOF DRAINAGE CRICKET PROFILES TO BE CONSTRUCTED WITH TAPERED INSULATION (TYP) MINIMUM 1/4" PER FOOT SLOPE.
5. NEW ROOF WALK PAD FROM ROOF ACCESS DOOR TO ROOF EQUIPMENT AND LADDERS.
6. HEIGHT OF NEW LADDERS AS LOCATED ARE TO BE FIELD VERIFIED. ANY LADDERS EXCEEDING A 20'-0" RISE WILL BE NOT ONLY AN OSHA COMPLIANT FIXED LADDER BUT WILL HAVE A CAGE INSTALLED AS PER OCCUPATIONAL SAFETY AND HEALTH ADMINISTRATION DOCUMENT 1910.27. A SAFETY CLIMB DEVICE IS TO BE PROVIDED TO ALL LADDERS WITHOUT A CAGE. NOTE THAT LADDERS MUST INCLUDE LANDING AT HEIGHT OF TOP OF PARAPET AND MUST THEN STEP DOWN APPROXIMATELY 3'-0" TO ROOF LEVEL. LADDER ACCESS AT GROUND LEVEL WILL BE FITTED WITH LOCKING ACCESS DEVICE.
 LADDER 1: APPROXIMATELY 17'-0" PLUS 3'-0" PARAPET.
 LADDER 2: APPROXIMATELY 15'-0" PLUS 3'-0" PARAPET.
7. CONTRACTOR TO VERIFY AT EACH EXISTING ROOF CURB WHETHER THE APPURTENANCE IS STILL IN USE. ANY ROOF CURBS NO LONGER NECESSARY ARE TO BE REMOVED. EXISTING OPENINGS IN CONCRETE DECK TO BE IN FILLED WITH CONCRETE.
8. REMOVE EXISTING EXHAUST PIPE STACK. NEW CURB IS TO BE PROVIDED AND INSTALLED. EXISTING GUY WIRES BRACING STACK ARE TO BE REMOVED AND INSTALLED IN NEW ANCHORED CURBS. ALL THREE CURBS WILL BE ANCHORED TO THE ROOF AND NOT TO ANY PORTION OF THE PARAPET ROOFING ASSEMBLY OR COPING.
9. INSTALLATION AROUND THE PERIMETER OF THE ROOF IS TO INCLUDE CONTINUOUS CANT STRIPS AS PART OF THE INSTALLATION. MODIFY INTERSECTION OF ROOF TO WALL AS REQUIRED FOR SAFE AND WATERTIGHT ROOF TERMINATION AT EXISTING DOOR THRESHOLD AND EXISTING LOUVER SILL. PROVIDE NEW ALUMINUM THRESHOLD IN LIEU OF COPING AT DOOR THRESHOLD.
10. NEW LIGHTNING PROTECTION SYSTEM, INSTALL PER MANUFACTURER. SPECIFICATION SECTION 26 41 00 FACILITY LIGHTNING PROTECTION.
11. EXISTING LEAD FLASHED VENT STACK. VERIFY LOCATION. REMOVE LEAD AND INSTALL ADJUSTABLE PIPE VENT CURB AND ANCHOR CURB TO ROOF STRUCTURE. ALL NEW PIPE, FAN AND EQUIPMENT CURBS WILL BE ANCHORED TO ROOF SUBSTRATE ABLE TO RESIST DEVELOPED HURRICANE WIND PRESSURES.
12. CONTRACTOR TO DISCONNECT, REMOVE, TEMPORARY STORE, AND REINSTALL THE BUILDING LIGHTNING PROTECTION SYSTEM. CONTRACTOR TO PROVIDE CERTIFICATION THAT THE SYSTEM WAS REINSTALLED CORRECTLY AND TESTED.

NO.	DATE	DR	CHK	REVISION	BY	APVD	SEAL/NAME

3011 SW WILLISTON ROAD
 GAINESVILLE, FLORIDA 32608
 EB0000072 AAC001982
 BETH A. TRAUTWEIN

ADMIN BUILDING ROOF REPLACEMENT
 KEY WEST, FLORIDA
 CITY OF KEY WEST
 RICHARD A. HAYMAN EPF

CH2MHILL®
 ARCHITECTURAL
 OPERATIONS BUILDING
 ROOF PLAN

AS NOTED
 VERIFY SCALE
 BAR IS ONE INCH ON ORIGINAL DRAWING.
 0 1"

DATE AUGUST 2015
 PROJ 650974
 DWG A-2
 SHEET ShtNum of ShtTot

© CH2M HILL 2015. ALL RIGHTS RESERVED.
 THIS DOCUMENT, AND THE IDEAS AND DESIGNS INCORPORATED HEREIN, AS AN INSTRUMENT OF PROFESSIONAL SERVICE, IS THE PROPERTY OF CH2M HILL AND IS NOT TO BE USED, IN WHOLE OR IN PART, FOR ANY OTHER PROJECT WITHOUT THE WRITTEN AUTHORIZATION OF CH2M HILL.
 REUSE OF DOCUMENTS:

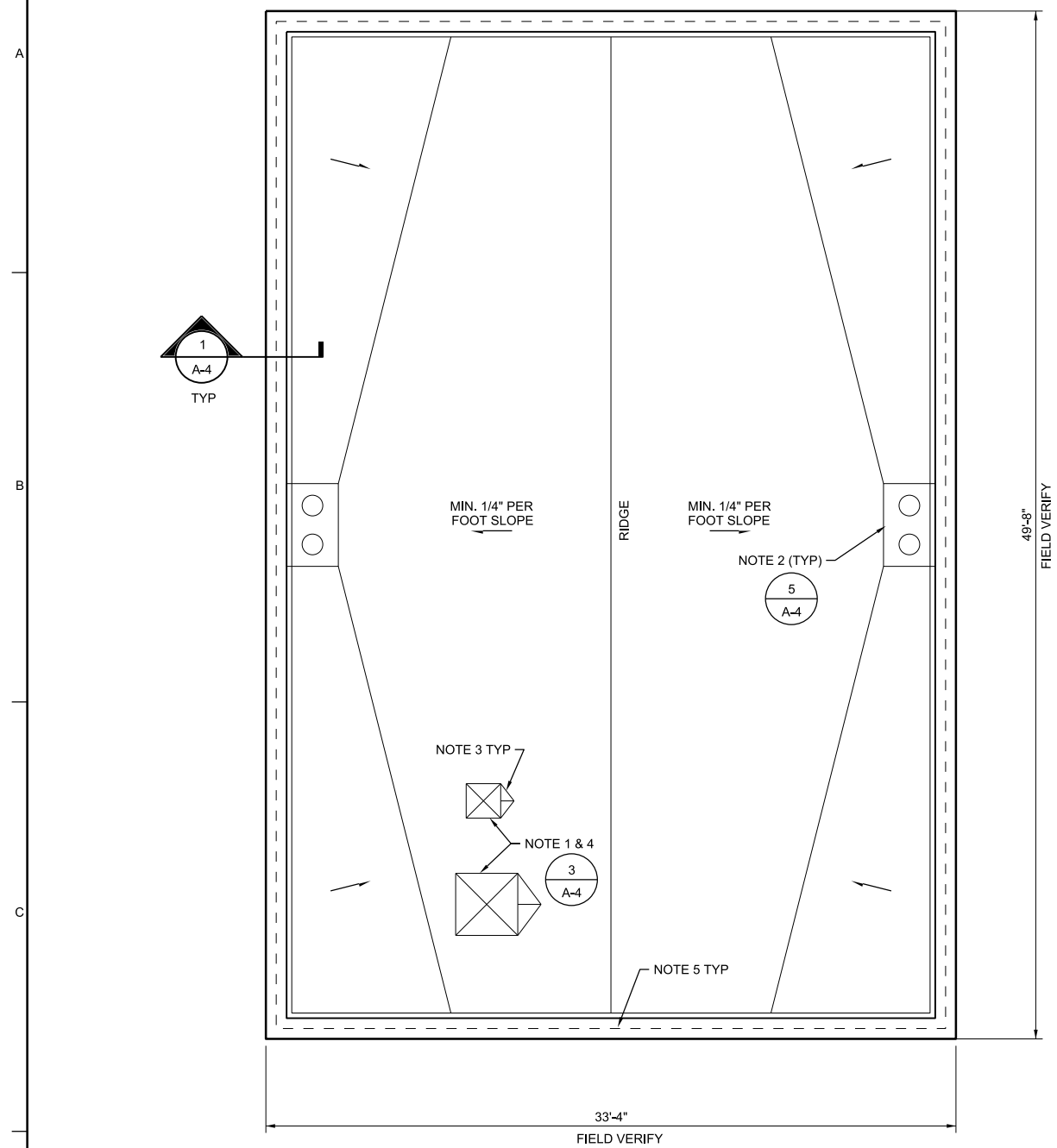

ROOF PLAN - CHLORINE BUILDING
 1/4"=1'-0"

ROOFING NOTES:

1. REMOVE EXISTING FAN ASSEMBLIES AND CURB TO CONCRETE SUBSTRATE. EXISTING FAN ASSEMBLIES TO BE REINSTALLED ON NEW EQUIPMENT CURBS. ALL NEW PIPE, FAN AND EQUIPMENT CURBS WILL BE CONNECTED TO ROOF SUBSTRATE FOR HURRICANE FORCE RESISTANCE. CONTRACTOR TO CONTACT ENGINEER IMMEDIATELY IF FAN ASSEMBLIES ARE IN POOR CONDITION OR CANNOT BE REINSTALLED.
2. EXISTING ROOF DRAINS:
 - A. BOTH PRIMARY DRAIN AND OVERFLOW DRAIN ASSEMBLIES ARE TO BE REMOVED DOWN TO CONCRETE SUBSTRATE.
 - B. IDENTIFY WHICH IS THE PRIMARY ROOF DRAIN LINE. CONTRACTOR RESPONSIBLE FOR TAGGING EXISTING DRAIN LINES AS PRIMARY AND EMERGENCY DURING ROOF DEMOLITION.
 - C. PIPE CONNECTION FROM EACH DRAIN INLET IS TO BE EXAMINED FOR CORROSION OR DAMAGE THAT IMPEDES CONNECTION OF DRAIN LINES TO NEW GAGE DRAIN COVERS. NOTIFY ENGINEER IF REMOVAL OF DRAINS REVEALS INSTALLATION ISSUES.
 - D. INLET ELEVATION OF EMERGENCY OVERFLOW DRAINS TO BE A MINIMUM OF 3" HIGHER THAN PRIMARY ROOF DRAINS.
 - E. EXISTING SUMP PROFILES DO NOT MEET CODE. ROOF INSTALLER TO EITHER RE-PROFILE SUMP AREAS OF EACH DRAIN COMBINATION BY CHANGING ROOF SLOPE OR ADDING ACTUAL METAL CURB TO SET EMERGENCY DRAIN COVER HIGHER.
 - F. NEW PRIMARY ROOF DRAIN AND EMERGENCY OVERFLOW ROOF DRAIN MUST BE COMBINED INTO AN INTEGRATED LEVEL SUMP AREA (TYP).
3. ROOF DRAINAGE CRICKET PROFILES TO BE CONSTRUCTED WITH TAPERED INSULATION (TYP) MINIMUM 1/4" PER FOOT SLOPE.
4. ANY ROOF CURBS NO LONGER NECESSARY ARE TO BE REMOVED. EXISTING OPENINGS IN CONCRETE DECK TO BE IN FILLED WITH CONCRETE. SEE DETAIL 9, DRAWING A-05.
5. NEW LIGHTENING PROTECTION SYSTEM, INSTALL PER MANUFACTURER'S RECOMMENDATIONS. SEE DETAIL 8, FOR RODS INSTALLED ON ACTUAL ROOF SURFACE.
6. CONTRACTOR TO NOTIFY ENGINEER IF EXISTING FANS ARE DAMAGED, CORRODED OR ARE NOT IN GOOD CONDITION FOR RE-INSTALLATION.
7. CONTRACTOR TO DISCONNECT, REMOVE, TEMPORARY STORE, AND REINSTALL THE BUILDING LIGHTNING PROTECTION SYSTEM. CONTRACTOR TO PROVIDE CERTIFICATION THAT THE SYSTEM WAS REINSTALLED CORRECTLY AND TESTED.

CH2MHILL® ARCHITECTURAL CHLORINE BUILDING ADDITIVE ALTERNATE ROOF PLAN		3011 SW WILLISTON ROAD GAINESVILLE, FLORIDA 32608 EB0000072 AAC001982 BETH A. TRAUTWEIN	ADMIN BUILDING ROOF REPLACEMENT KEY WEST, FLORIDA CITY OF KEY WEST RICHARD A. HAYMAN EPF
1/4"=1'-0" VERIFY SCALE BAR IS ONE INCH ON ORIGINAL DRAWING.		REUSE OF DOCUMENTS: THIS DOCUMENT, AND THE IDEAS AND DESIGNS INCORPORATED HEREIN, AS AN INSTRUMENT OF PROFESSIONAL SERVICE, IS THE PROPERTY OF CH2M HILL AND IS NOT TO BE USED, IN WHOLE OR IN PART, FOR ANY OTHER PROJECT WITHOUT THE WRITTEN AUTHORIZATION OF CH2M HILL.	
DATE AUGUST 2015 PROJ 650974 DWG A-3 SHEET ShtNum of ShtTot	NO. DATE DSGN	DR P DENNING CHECKED-BY APVD	REVISION CHK APVD SEAL/NAME

BID DOCUMENTS

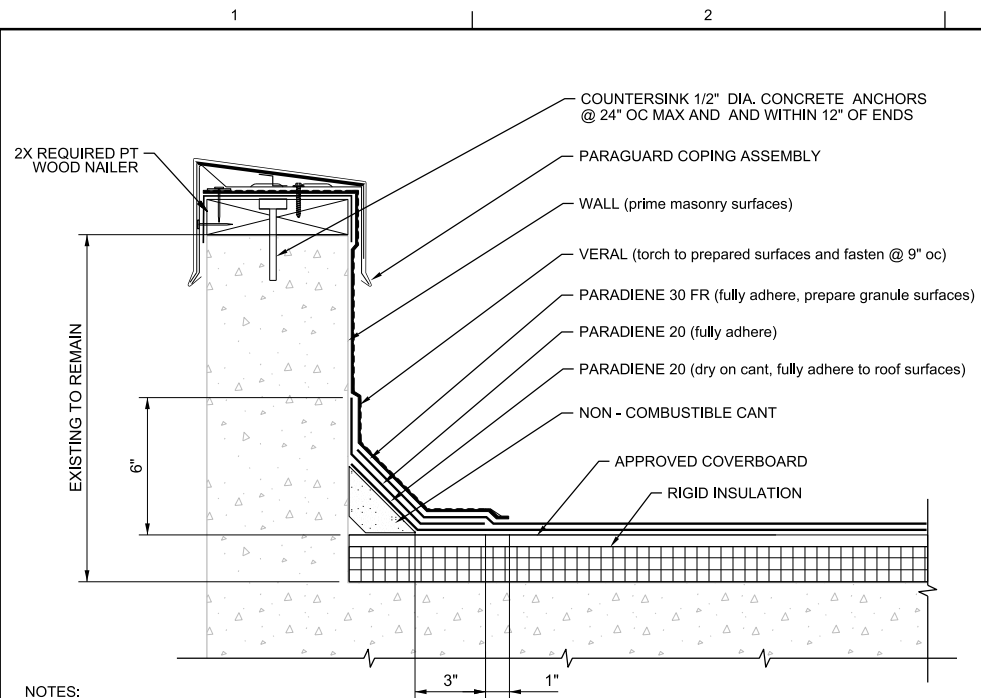

- NOTES:**
1. REFER TO THE PARAGUARD ROOF PERIMETER SYSTEM CATALOGUE AND PARAGUARD COPING INSTALLER'S GUIDE FOR INFORMATION ON PRODUCTS, SIZING AND INSTALLATION OF THE PARAGUARD SYSTEM.
 2. PREPARE GRANULE SURFACES UNDER VERAL FLASHING BY TORCH PREPARATION.
 3. THE CARPENTRY SHOWN DEPICTS JOB-SITE ASSEMBLY AND SHOULD BE CONSTRUCTED ACCORDING TO GENERALLY ACCEPTED PRACTICES, STANDARDS AND APPROVALS.
 4. A NAILER AND TREATED WOOD CANT MAY BE REQUIRED FOR COMPLIANCE WITH SPECIFIC BUILDING CODES OR APPROVALS.
 5. REQUIREMENTS AND RECOMMENDATIONS DETAILED IN SIPLAST SPECIFICATIONS SHALL APPLY IN ADDITION TO THE ABOVE DRAWING.

1 PARAPET DETAIL
3"=1'-0"

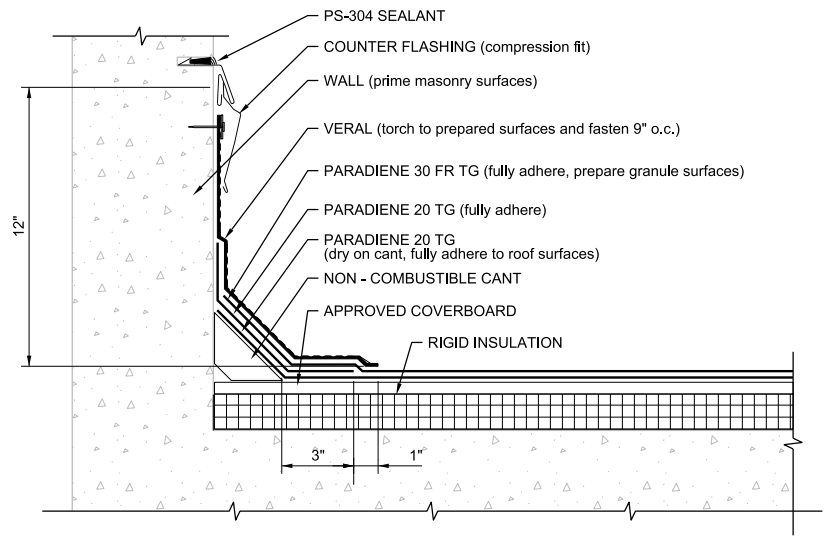

2 END WALL FLASHING
3"=1'-0"

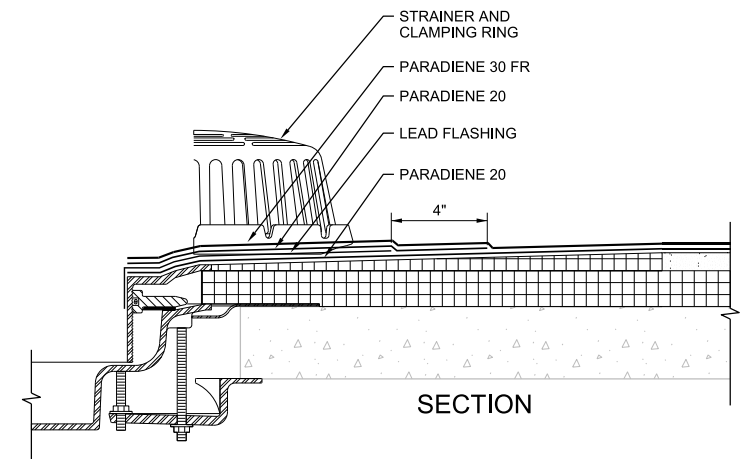
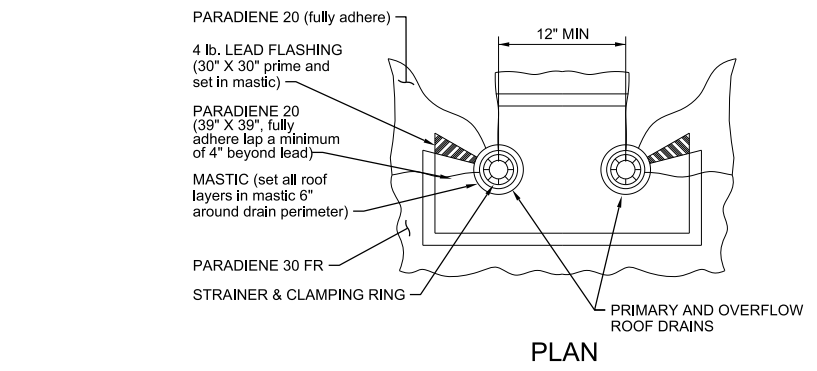

5 ROOF DRAIN
3"=1'-0"

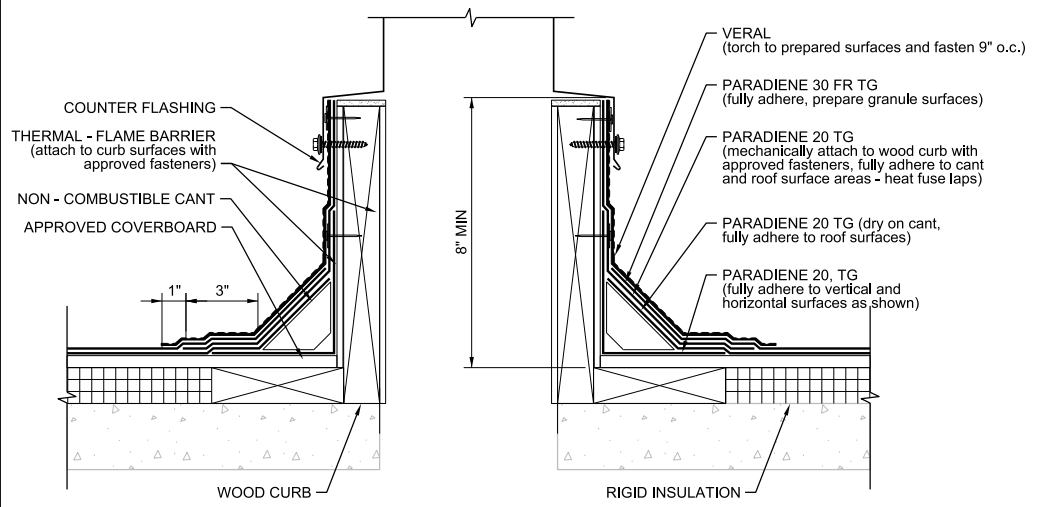

3 EQUIPMENT CURB
3"=1'-0"

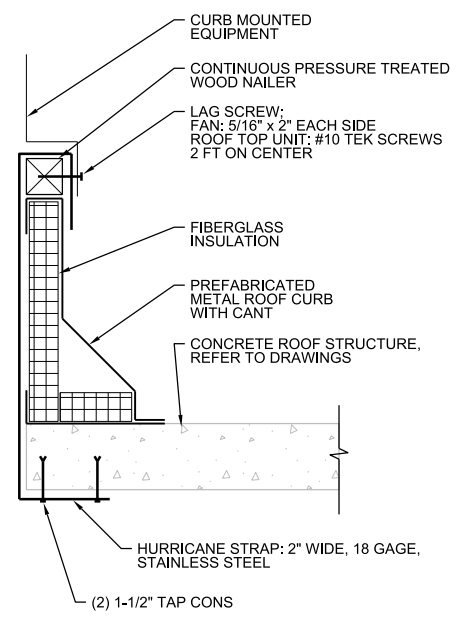

4 HURRICANE RESISTANT EQUIPMENT CURB STRAPS
3"=1'-0"

NOTE: HURRICANE RESTRAINT STRAPS ARE TO BE RETROFITTED FOR USE FROM PRODUCTS MADE FOR PRIMARILY WOOD CONSTRUCTION. CONTRACTOR IS TO PLACE STRAPS 12" OC AROUND THE PERIMETER OF ALL NEW AND EXISTING CURBS AND EXISTING ROOF HATCHES. MINIMUM 2 RESTRAINTS PER SIDE OF CURB OR HATCH.

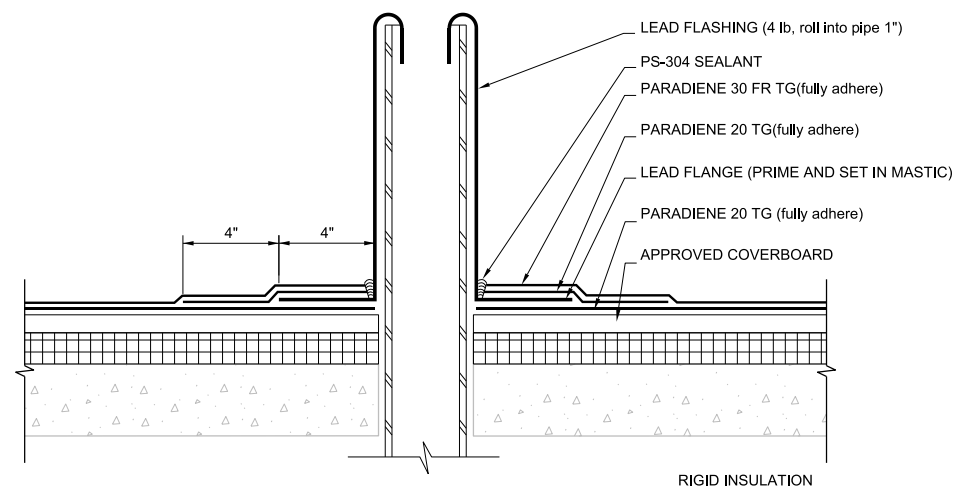

6 PIPE THROUGH ROOF
3"=1'-0"

3011 SW WILLISTON ROAD GAINESVILLE, FLORIDA 32608 EBR0000072 AAC001992		ENGINEERS SEAL NAME		ADMIN BUILDING ROOF REPLACEMENT KEY WEST, FLORIDA CITY OF KEY WEST RICHARD A. HAYMAN EPF	
CH2MHILL®		ARCHITECTURAL		DETAILS	
DATE		AUGUST 2015		3"=1'-0"	
PROJ		650974		VERIFY SCALE	
DWG		A-04		BAR IS ONE INCH ON ORIGINAL DRAWING.	
SHEET		ShtNum of ShtTot		0 1"	

P DENNING
 B TRAUTWEIN
 DR
 NO. DATE
 DSGN
 REVISION
 CHK
 APVD
 BY
 APVD
 SEAL NAME

REUSE OF DOCUMENTS: THIS DOCUMENT AND THE IDEAS AND DESIGNS INCORPORATED HEREIN, AS AN INSTRUMENT OF PROFESSIONAL SERVICE, IS THE PROPERTY OF CH2M HILL AND IS NOT TO BE USED, IN WHOLE OR IN PART, FOR ANY OTHER PROJECT WITHOUT THE WRITTEN AUTHORIZATION OF CH2M HILL.
 © CH2M HILL 2015. ALL RIGHTS RESERVED.

