

Notice to Bidder: Use Black Ink or Type For Completing the Form.

**BID**

**To:** The City of Key West  
**Address:** 525 Angela Street, Key West, Florida 33040  
**Project Title:** BAYVIEW PARK RESTROOM CONSTRUCTION  
**Project:** ITB #11-006

**BIDDER'S INFORMATION**

**Name:** BELLA CONSTRUCTION OF KEY WEST, INC.  
**Address:** 111 US HIGHWAY 1  
BOX 110  
KEY WEST, FL 33040  
**Contact Name:** EDDIE BRASWELL or BRYAN WOFSEY  
**Email:** EDDIE@CONCRETEBELLA.COM or BRYAN@CONCRETEBELLA.COM  
**Telephone:** 305.292.9888  
**Fax:** 305.292.9880

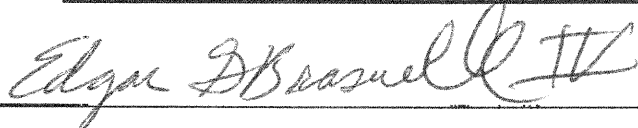
**Signature:**  **Date:** 2.16.11

**BIDDER'S DECLARATION AND UNDERSTANDING**

The undersigned, hereinafter called the Bidder, declares that the only persons or parties interested in this Bid are those named herein, that this Bid is, in all respects, fair and without fraud, that it is made without collusion with any official of the Owner, and that the Bid is made without any connection or collusion with any person submitting another Bid on this Contract.

The Bidder further declares that he/she has carefully examined the Contract Documents for the construction of the project, that he/she has personally inspected the site, that he/she has satisfied himself/herself as to the quantities involved, including materials and equipment, and conditions of work involved, including the fact that the description of the quantities of work and materials, as included herein, is brief and is intended only to indicate the general nature of the work and to

identify the said quantities with the detailed requirements of the Contract Documents, and that this Bid is made according to the provisions and under the terms of the Contract Documents, which Documents are hereby made a part of this Bid.

The Bidder further agrees that he/she has exercised his/her own judgment regarding the interpretation of job conditions and has utilized all data, which he/she believes pertinent from the Project Manager, Owner, and other sources in arriving at his/her conclusions.

The intent of the Bid Documents is to describe a functionally complete project (or part thereof) to be constructed in accordance with the Contract Documents. Any work, materials, or equipment that may reasonably be inferred from the Contract Documents, as being required to produce the intended result shall be supplied whether or not specifically called for.

### **CONTRACT EXECUTION AND BONDS**

The Bidder agrees that if this BID is accepted, he/she will, within twenty (20) calendar days after Notice of Award, sign the Contract in the form annexed hereto, will attach all required licenses and certificates, and will, to the extent of his BID, furnish all equipment, materials, and labor necessary to complete all work as specified or indicated in the Contract Documents. Performance and Payment Bonds will be required as part of this contract.

### **CERTIFICATES OF INSURANCE**

Bidder agrees to furnish the Owner, before commencing the work under this Contract, the certificates of insurance as specified in these Documents.

### **START OF CONSTRUCTION AND CONTRACT COMPLETION TIME**

The Bidder further agrees to begin work within twenty (20) calendar days after the date of the Notice to Proceed and to complete the construction of all items in bid, in all respects, for this particular project, within ninety (90) calendar days after the date of the Notice to Proceed.

### **LIQUIDATED DAMAGES**

In the event the Bidder is awarded the Contract and shall fail to complete the work within the time limit or extended time limit agreed upon as more particularly set forth in the Contract Documents, liquidated damages shall be paid to the Owner at the rate of two hundred fifty dollars (\$250.00) per day for all work awarded under this contract until the work has been satisfactorily completed as provided by the Contract Documents. Sundays and legal holidays shall be included in determining days in default.

### **ADDENDA**

The Bidder hereby acknowledges that he has received Addenda No's. 1 , 2 , 3 , 4 ,  
, (Bidder shall insert No. of each Addendum received) and agrees that all addenda issued

are hereby made part of the Contract Documents, and the Bidder further agrees that his Bid(s) includes all impacts resulting from said addenda.

#### **SALES AND USE TAXES**

The Bidder agrees that all federal, state, and local sales and use taxes are included in the stated Bid prices for the work.

#### **PUBLIC ENTITY CRIMES**

“A person or affiliate who has been placed on the convicted vendor list following a conviction for a public entity crime may not submit a Bid on a contract to provide any goods or services to a public entity, may not submit a Bid on a contract with a public entity for the construction or repair of a public building or public work, may not submit Bids on leases of real property to a public entity, may not be awarded or perform work as a contractor, supplier, subcontractor, or consultant under a contract with any public entity and may not transact business with any public entity in excess of the threshold amount provided in Section 287.017, for CATEGORY TWO for a period of 36 months from the date of being placed on the convicted vendor list.”

#### **LUMP SUM PRICE BID**

The Bidder agrees to accept as full payment for performance of the work as herein specified and shown on the Drawings (if any), the Lump Sum on the Bid Form. The Bidder agrees that the Lump Sum represents a true measure of the design, labor, materials, and equipment required to perform the work, including all allowances for overhead and profit for each type and unit of work called for in these Contract Documents.

**ADDENDUM NO. 1**  
**Bayview Park Restroom Construction**

**To All bidders:**

**The following is hereby made a part of ITB 11-006 – Bayview Park Restroom Construction as fully as completely as if the same were fully set forth therein:**

**Bayview Park Restrooms Site Location “C”**

**Bayview Park Restrooms A1**

**Bayview Park Restrooms A2**

**Bayview Park Restrooms A3**

**Bayview Park Restrooms A4**

**Page 84 – 88 in original documents have been replaced with the attached pages 1-6.**

**All bids shall acknowledge receipt and acceptance of their Addendum No. 1 by acknowledging Addendum in their bid or by submitting the Addendum with the bid package. Bids submitted without acknowledgement or without this Addendum may be considered non-responsive.**

  
**Signature**

  
**Name of Business**



**ADDENDUM 2:  
ITB #11-006 BAYVIEW PARK RESTROOMS CONSTRUCTION**

To all general contract bidders of record on the Work titled:

**BAYVIEW PARK RESTROOMS  
KEY WEST, FLORIDA**

This addendum is issued as supplemental information to the ITB # 11-006 package for clarification of certain matters of both a general and a technical nature. The referenced ITB package is hereby addended in accordance with the following items as fully as completely as if the same were fully set forth therein:

The following clarifications and/or modifications address issues raised at the mandatory pre-bid conference held on site, February 2, 2011:

**ITEM #1: EXISTING SITE CONDITIONS**

It was disclosed by City Staff that a cistern exists on site under the proposed building location. The cistern is approximately 20 feet square and 8 feet deep, constructed of concrete with walls and bottom of 12 to 18 inches thick. The cistern was filled, but not compacted. Include amounts in your bid to cover the following.

- a) Auger pile foundations must penetrate 36" into cap rock. Assume that all augers will extend 15 feet below the grade surface. The 3 foot penetration is required and actual auger depths will be determined by this criteria, either more or less as needed.
- b) It is assumed that the cistern bottom is solid. In order to minimize the potential for sub grade degradation, provide 2 auger holes within the building perimeter that punch through the cistern bottom that will facilitate drainage of any water buildup under the slab. Backfill the holes below the concrete with ¾" plus aggregate.
- c) In order to minimize impact on the site from the extension of underground utilities, run water, sewer and electric from the street under the existing basketball courts to the new building. Patch back all asphalt surfaces. *(Hot-Patch Only)*
- d) Protection of existing trees, including roots and canopies will be required in accordance with all City regulations. Fully coordinate all requirements with City Landscape Coordinator, Cynthia Domenech-Coogle.

**ITEM #2: PLUMBING**

- a) Run a new 2" water line, meter, and RPZ from the street to the building.
- b) All underground water services piping to the building may be CPVC. All waterlines within the building shall be Type "L" copper as specified.

**ITEM #3: SIGNAGE**

The only signage required are the 6 unisex ADA accessible restroom signs shown on the drawings.

**ITEM #4: ACCESSORIES**

The City will provide paper towel dispensers, soap dispensers and toilet paper holders to be installed by the Contractor. All other accessories will be furnished and installed by the Contractor as shown on the drawings.

**ITEM #5: EXTERIOR WALL FINISH**

Finish exterior masonry walls with a 3 coat stucco finish. Other finishing specifications, including painting with the specified Loxon paint system shall remain.

**ITEM #6: DOORS AND DOOR FRAMES**

Delete grilles in doors. A F.B.C approved N.O.A. will be required. A review of Miami Dade N.O.A.'s indicates that most fiberglass doors were tested using wood frames. Some were tested with fiberglass frames. Steel frames are typically tested with steel doors. Since tests are conducted as an assembly, the door and frame must be installed in accordance with the N.O.A. The City desires as low a maintenance installation as possible. Therefore, use of a fiberglass frame will be acceptable in lieu of stainless steel as shown. The City's first choice, if available, is a fiberglass door in a stainless steel frame. The lockset must be stainless steel, key lockable from the outside and automatically unlocks upon exit. Schlage L9496, privacy with "Occupied" indicator. Lever retracts latch bolt from either side. Deadbolt thrown or retracted by key outside (retraction by key required in the event of an emergency) or inside thumb turn. Throwing deadbolt locks outside knob/lever and displays "Occupied" plate. Rotating inside knob/lever simultaneously retracts both deadbolt and latch bolt and unlocks outside knob/lever. Inside lever is always free for immediate egress. Provide ADA threshold. No weather stripping is required.

**ITEM # 7: SITE SAFETY:**

All work conducted on City property require the use of Best Management Practices. Safety procedures for this project are in accordance with OSHA regulations. A six (6) foot chain link fence with gate is required to secure the perimeter of the site.

**ITEM #8: END STATE:**

At the conclusion of the project, all grounds, vegetation, sidewalks, basketball court will be restored to at least the preconstruction condition.

**END OF ADDENDUM No. 2**

All Bidders shall acknowledge receipt and acceptance of this Addendum No. 2 by acknowledging Addendum in their proposal or by submitting the addendum with the bid package. Bids submitted without acknowledgement or without this Addendum may be considered non-responsive.

*Edgar G Braswell III*  
Signature Name of Business Bella Construction



**ADDENDUM 3:  
ITB #11-006 BAYVIEW PARK RESTROOMS CONSTRUCTION**

To all general contract bidders of record on the Work titled:

**BAYVIEW PARK RESTROOMS  
KEY WEST, FLORIDA**

This addendum is issued as supplemental information to the ITB # 11-006 package for clarification of certain matters of both a general and a technical nature. The referenced ITB package is hereby addended in accordance with the following items as fully as completely as if the same were fully set forth therein:

**ITEM #1: CONTRACTORS INFORMATIONAL SHEET FOR TREES AND CONSTRUCTION**

Sec. 108-447(b) During the construction stage of development, the developer shall not cause or allow the cleaning or storage of equipment or material, within the dripline of any tree or groups of trees to be maintained. The developer shall provide and maintain protective barriers, in a form to be approved by the landscape coordinator, around all landscaping existing on site prior to construction. The developer shall not cause or allow the disposal of waste material such as paint, oil, solvents, asphalt, concrete, mortar or any other material harmful to the life of a tree within the dripline of any tree or groups of trees.

1. Trees to be protected shall be centered within protective barrier
2. Protective barrier shall be enlarged when necessary to enclose all exposed roots.

Sec. 108-454. (a) *Attachments to trees prohibited.* It shall be unlawful to attach anything to a tree trunk or stem having a diameter of six inches or more, other than protective wires, braces or other similar noninjurious materials.

(b) *Excessive cut and/or fill.* It shall be unlawful to remove any material or ground within the dripline of a tree which is necessary for the growth of the subject tree. Also, when raising the existing grade of a site, it shall be unlawful to raise the grade within the tree's dripline more than six inches without incorporating retaining walls to preserve the tree's root system.

Sec. 110-366. Protective barricades; performance bond.

All trees on a site shall be protectively barricaded before and during construction activities. The minimum barricading shall be subject to review by the city landscape division. Upon a vote of the tree commission, a performance bond in addition to a protective barricade may be required from the agent or owner for any tree protection, removal or transplanting to guarantee protection of a tree or to ensure restoration of an equivalency. The amount of such bond shall be based on the equivalent value of the tree specifically covered. Any bond required for a protected tree shall be four times the equivalent value for that tree, but in no event shall exceed \$5,000.00.

**Protective barricades shall be in place and inspected prior to commencement of work.**

## Mulch Protection for Exposed and Subsurface Roots

Cover root systems with either 5" of mulch and sheets of plywood or 10" of mulch. Mulch and or plywood shall be continuous and maintained in perpetuity of job.

An International Society of Arboriculture (ISA) Certified Arborist is required to be onsite at all times during work within the dripline of a tree. Certified Arborist shall repair any damage including corrective damage to roots exposed during trenching or damages to any portion of trees, i.e., roots, trunk, branches and/or canopy.

### ITEM #2:

Q: In order to save money, can the new Electrical Service Feed come from the existing 400 amp Panel that is adjacent to the New Restroom Area? According to the electrician, this existing Panel has plenty of Power for this New Structure.

A: **NEW SERVICE IS REQUIRED**

### ITEM #3:

Q: Additionally, can the Electrical Meter be relocated to the Rear Side of the Structure to minimize this Run?

A: **YES**

### ITEM #4:

Q: There are no Water Supply Lines shown on these Plans. Please specify the size of the Water Lines required for this project.

A: **Run a 2" line from the street to the building with RPZ and RPZ cage . The specified Sloan flush valve has a 1" I.P.S. supply, the faucet set connection is 1/2". Comply with the manufacturer's requirements for installation.**

### ITEM #5:

Q: Will these details be needed in order to obtain a Building Permit?

A: **No, the city requires waste riser diagrams but not water line schematics.**

Q: If so, will this service be provided by the City?

A: **If required by the building department, Bender will provide them.**

Q: If not, will there be additional time granted in order to produce these drawings?

A: **No.**

### ITEM #6:

Q: What size Water Meter is required for this Project?

A: **FKAA determines the meter size.**

### ITEM #7:

Q: Will the Contractor need to Cover any Impact Fees for this Project?

A: **No, the specifications state that the owner pays impact fees and the contractor pays permit fees.**

### ITEM #8:

Q: Sheet A3 shows Ceramic Tile at Walls and Floors. Please confirm desired finish at both the Interior Walls and the Floor.

A: **Tile finishes are called out on the notes on sheet A-3, floor plan 1/ A-3.**



**ITEM #9:**

**Q:** Will the 5-V Crimp Metal Roof be Galvalume . If this Metal Roof is painted in the Field, will this violate any warranty criteria.

**A:** That depends on the manufacturer.

**ITEM #10:**

**Q:** In order to save money on the Gable End Walls, can we run the 8" CMU Block up through the Gable End and cap it with the 8" x 16" Raked Tie Beam?

**A:** Yes, this is an acceptable substitution.

**ITEM #11:**

**Q:** Sheet SP1 shows 4" thickness Compacted Aggregate Course while Sheet A3 shows 6" thickness. Please confirm the Minimum Thickness of this Compacted Aggregate Base Course.

**A:** See General Note #4 on the cover sheet.

**ITEM #12:**

**Q:** If the asphalt basketball court is disturbed, can we use Cold-Patch Asphalt as a Repair?

**A:** Hot patch only and installed as per manufacture specification.

**ITEM #12: GRAB BARS**

**Q:** What type of Grab Bars are required?

**A:** See attached technical data sheet. Owner is not specifying manufacturer, but rather specifications.

**Q:** How many Grab Bars per Bathroom?

**A:** See attached technical data sheet. Owner is not specifying manufacturer, but rather specifications.

**Q:** What size Grab Bars?

**A:** See attached technical data sheet. Owner is not specifying manufacturer, but rather specifications.

**END OF ADDENDUM No. 3**

All Bidders shall acknowledge receipt and acceptance of this Addendum No. 3 by acknowledging Addendum in their proposal or by submitting the addendum with the bid package. Bids submitted without acknowledgement or without this Addendum may be considered non-responsive.

  
Signature Name of Business Bella Construction



**Technical Data**

**1½" (38mm) DIAMETER  
STAINLESS STEEL GRAB  
BARS WITH SNAP FLANGE**

**B-6806  
SERIES**

Specify Finish Required:

- Satin finish
- Satin finish with peened gripping surface; add suffix .99 to model number

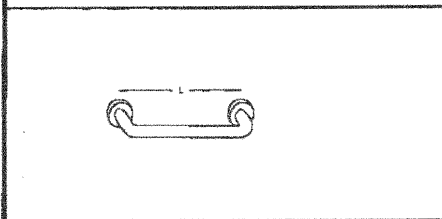
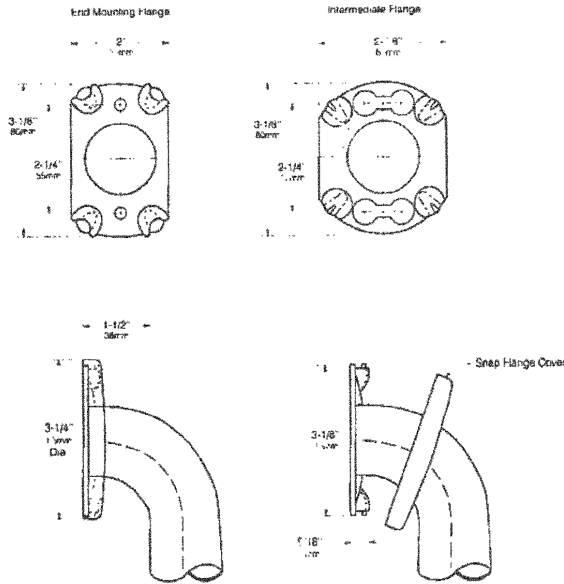

HORIZONTAL

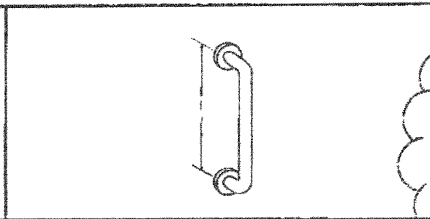

VERTICAL

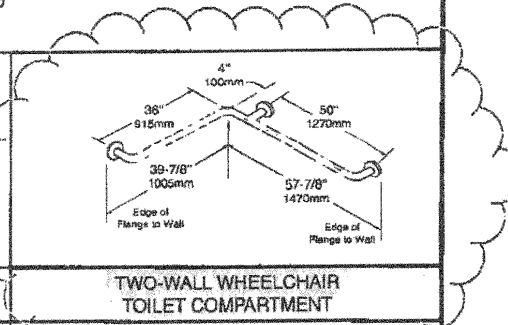

TWO-WALL WHEELCHAIR  
TOILET COMPARTMENT

B-6806 x 12, 18, 24, 30, 36, 42, 48

B-68137

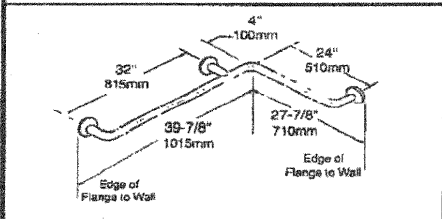

HORIZONTAL TUB BATH  
24 x 36

B-68616

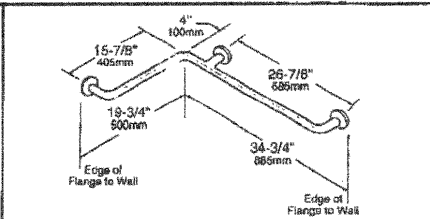

HORIZONTAL TWO-WALL BAR  
for Shower Stall

B-6861

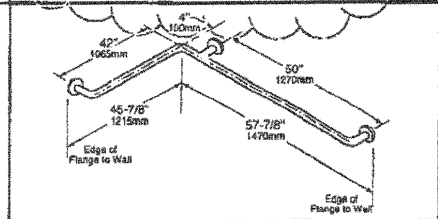

TWO-WALL  
TOILET COMPARTMENT BAR 42 x 54

B-6897

continued...

The illustrations and descriptions herein are applicable to production as of the date of this Technical Data Sheet. The manufacturer reserves the right to, and does from time to time, make changes and improvements in designs and dimensions.

**MATERIALS:**

**Grab Bar** — 18-8 S, type-304, 18-gauge (1.2mm) stainless steel tubing with satin-finish, 1-1/2" (38mm) outside diameter. Ends are heliarc welded to flanges. Clearance between the grab bar and wall is 1-1/2" (38mm).

**Concealed Mounting Flanges** — 18-8 S, type-304, 1/8" (3mm) thick, stainless steel plate; end flanges 2" x 3-1/8" (50 x 80mm) with two holes for attachment to wall. Intermediate flanges 2-5/8" x 3-1/8" (65 x 80mm) wide x 3-1/8" (80mm) diameter.

**Snap Flange Covers** — 18-8 S, type-304, 22-gauge (0.8mm) drawn stainless steel with satin-finish, 3-1/4" (85mm) diameter x 1/2" (13mm) deep. Each cover snaps over mounting flange to conceal mounting screws.

**STRENGTH:**

Bobrick grab bars that provide 1-1/2" (38mm) clearance from wall can support loads in excess of 900 pounds (408kg) if properly installed. Other grab bar configurations can support loads in excess of 250 pounds (113kg) if properly installed, complying with barrier-free accessibility guidelines (including ADAAG in the U.S.A.) for structural strength

**Warning:** Grab bars are no stronger than the anchors or walls to which they are attached and, therefore, must be firmly secured in order to support the loads for which they are intended.

**INSTALLATION:**

Provide concealed anchor device or backing as specified or required in accordance with local building codes before wall is finished. Fasten concealed mounting flanges to anchor device or backing with two screws in each flange. Snap flange covers over each mounting flange to conceal mounting screws. Concealed anchor devices and mounting screws are not included with Bobrick grab bars and must be specified as an accessory.

For Grab Bars with an Intermediate Flange(s), Pull Snap-Flange Covers away from mounting flanges. Place grab bar in desired mounting location. Use intermediate flange as a template to mark location of mounting screws at intermediate flange only. Mark screw locations at the center of the slot in the middle of the double-keyhole shaped mounting holes (2) in the intermediate flange. Remove grab bar from wall. Drive the intermediate flange mounting screws into wall at marked locations. **Note:** Make sure to leave a space of just over 1/8" (3.17mm) between the underside of the screw head and the wall. Install grab bar on the wall by placing the round ends of the intermediate flange double-keyhole shaped mounting holes over the mounting screws (2) are located in the middle of the flange slots. Install the mounting screws into the wall at the end flanges and secure tightly. Tighten the mounting screws at the intermediate flange. Press all snap-flange covers into place to conceal mounting flanges.

**Note:** Recommend use of 1/4" or #14 (M6.3) sheet metal or wood screws to install Intermediate Flange. #12 (M5.5) screws may also be used.

**Important Notes:**

1. **Mounting Kits** — Bobrick has a selection of mounting screws and fasteners available for different types of installations; one Bobrick mounting kit is required for each flange.

Mounting Kit No.	Description
252-30	Consists of (3) #14 x 2 1/4" (M6.3 x 64mm) type-304 stainless steel, Phillips round-head, sheet-metal screws.
2521-30	Consists of (3) 1/4"-20 x 3 1/2" (M6.3-1 x 89mm) type-304 stainless steel, Phillips round-head, machine screws with plated-steel toggle nuts.
2522-30	Consists of (3) 1/4"-20 x 2" (M6.3-1 x 51mm) type-304 stainless steel, Phillips round-head, machine screws with metal expansion shields.

2. **Grab Bar Fastener** — Bobrick has a grab bar fastening system that secures all Bobrick grab bar series; one Bobrick fastener is required for each flange. Install grab bar without backing in wall requires minimum 5/8" (16mm) thick painted or tiled drywall.

WingIt™ Fastener No.	Description
251-4	Consists of (3) 10-32 x 5/16" round-head, Phillips 18/8 stainless steel screws. (1) WingIt grab bar fastener.

3. **Optional Anchor Device** — Bobrick grab bar anchor device includes stainless steel machine screws to be used for attaching grab bars to anchors. one Bobrick concealed anchor device is required for each flange.

Optional Anchor No.	Description
2583	Anchor for 3/4" to 1" (19-25mm) panel 1 anchor required for each flange.
2586	Anchor for 1/2" to 1" (13mm) panel 1 anchor required for each flange.

**SPECIFICATION:**

Grab bar shall be type-304 stainless steel with satin-finish. Grab bar shall have 18-gauge (1.2mm) wall thickness and 1-1/2" (38mm) outside diameter. Clearance between the grab bar and wall shall be 1-1/2" (38mm). Concealed mounting flanges shall be 1/8" (3mm) thick stainless steel plate, 2" x 3-1/8" (50 x 80mm), and equipped with two screw holes for attachment to wall. Flange covers shall be 22 gauge (0.8mm), 3-1/4" (85mm) diameter x 1/2" (13mm) deep, and shall snap over mounting flange to conceal mounting screws and/or WingIt fasteners. Ends of grab bar shall pass through concealed mounting flanges and be heliarc welded to form one structural unit. Grab bar shall comply with barrier-free accessibility guidelines (including ADAAG in the U.S.A.) for structural strength. Manufacturer's service and parts manual shall be provided to the building owner/manager upon request.

Grab Bar shall be Model \_\_\_\_\_ (insert model number) of Bobrick Washroom Equipment, Inc., Clifton Park, New York; Jackson, Tennessee; Los Angeles, California; Bobrick Washroom Equipment Company, Scarborough, Ontario; Bobrick Washroom Equipment Pty. Ltd., Australia; and Bobrick Washroom Equipment Limited, United Kingdom.

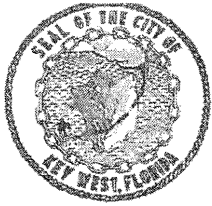

**ADDENDUM 4:  
ITB #11-006 BAYVIEW PARK RESTROOMS CONSTRUCTION**

To all general contract bidders of record on the Work titled:

**BAYVIEW PARK RESTROOMS  
KEY WEST, FLORIDA**

This addendum is issued as supplemental information to the ITB # 11-006 package for clarification of certain matters of both a general and a technical nature. The referenced ITB package is hereby addended in accordance with the following items as fully as completely as if the same were fully set forth therein:

**ITEM #1: WATER SYSTEM ON DRAWINGS**

Disregard any specifications for hot water or solar heater system. There is no hot water planned, nor is the solar system shown on the drawings.

**END OF ADDENDUM No. 4**

All Bidders shall acknowledge receipt and acceptance of this Addendum No. 3 by acknowledging Addendum in their proposal or by submitting the addendum with the bid package. Bids submitted without acknowledgement or without this Addendum may be considered non-responsive.

Edgar A. Beavell Bella Construction  
Signature Name of Business

**BID FORM**  
**ITB #11-006: BAYVIEW PARK RESTROOMS CONSTRUCTION**

**TOTAL BID PRICE** \$ 154,940.

**Total Bid Total in Words**

ONE HUNDRED FIFTY FOUR THOUSAND NINE HUNDRED FORTY DOLLARS

---

---

**BID BREAKDOWN**

The bidder shall provide a schedule of values for all aspects of the project including mobilization/demobilization, labor and materials, permitting, etc. required or to be used for the project. The schedule of values shall be in sufficient detail to allow the owner to understand how the bidder arrived at said bid price and shall become part of the contract for basis of payment. The City may ask for a more detailed schedule of values if one submitted is not sufficient.



ITB #11-006 BAYVIEW PARK RESTROOMS CONSTRUCTION

SCHEDULE OF VALUES

<i>DESCRIPTION</i>	<i>SOV</i>
PERMIT FEES, TREE PROTECTION, FENCING	\$10,500
DEMO & SITE PREPARATION	\$ 3,500
SHELL INCLUDING DOORS & METAL ROOF	\$57,560
PLUMBING	\$23,650
ELECTRICAL	\$19,600
INSULATION, DRYWALL & TILE	\$19,600
STUCCO, HARDIPLANK & PAINT	\$ 9,880
CONCRETE SIDEWALKS	\$ 4,800
BATHROOM ACCESSORIES & SIGNAGE	\$ 5,850
<b>TOTAL</b>	<b>\$154,940</b>

**FLORIDA BID BOND**

BOND NO. \_\_\_\_\_ n/a

AMOUNT \$ \_\_\_\_\_ 5% amt bid NTE \$12,500.00

**KNOW ALL MEN BY THESE PRESENTS, that**

Bella Construction of Key West, Inc., 111 US Hwy 1 Box 110, Key West FL 33040 (305)292-9888, hereinafter called the

PRINCIPAL, and American Southern Insurance Company, 1301 Hightower Trl #210, Atlanta GA 30350 (800)424-0132, a corporation duly

organized under the laws of the State of South Carolina having its principal place of business at

Columbia SC in the State of South Carolina and

authorized to do business in the State of Florida, as SURETY, are held firmly bound unto

hereinafter called the Obligee, in the sum of Five percent of amount bid, penal sum not to exceed twelve thousand five hundred

DOLLARS (\$ 5% amt bid NTE \$12,500.00 ) for the payment for which we bind ourselves, our

heirs, executors, administrators, successors, and assigns, jointly and severally, firmly by these presents..

**THE CONDITION OF THIS BOND IS SUCH THAT:**

WHEREAS, the PRINCIPAL is herewith submitting his or its Bid or Bid for:

ADD DOCUMENT NAME HERE said Bid, by reference thereto, being hereby made a part hereof.

WHEREAS, the PRINCIPAL contemplates submitting or has submitted a Bid to the OBLIGEE for the furnishing of labor, materials, (except those specifically furnished by the Owner), equipment, machinery, tools, apparatus, means of transportation for, and the performance of the work covered in the Bid and the detailed Specifications entitled:

ADD DOCUMENT NAME HERE

WHEREAS, it was a condition precedent to the submission of said Bid that a cashier's check, certified check, or Bid bond in the amount of five (5) percent of the Lump Sum Bid be submitted with said Bid as a guarantee that the Bidder would, if awarded the Contract, enter into a written Contract with the Owner for the performance of said Contract, within five (5) working days after written notice having been given of the award of the Contract.

NOW, THEREFORE, the conditions of this obligation are such that if the PRINCIPAL within five (5) working days after written notice of such acceptance, enters into a written Contract with the OBLIGEE then this obligation shall be void: otherwise the sum herein stated shall be due and payable to the OBLIGEE and the Surety herein agrees to pay said sum immediately upon

Obligee: City of Key West, 525 Angela St, Key West FL 33040

Project: ITB11-006 - Bayview Park Restrooms Construction

demand of the OBLIGEE in good and lawful money of the United States of America, as liquidated damages for failure thereof of said principal.

Signed and sealed this 16th day of, Feb 2011.

Bella Construction of Key West, Inc.

**PRINCIPAL**

  
By

American Southern Insurance Company

**SURETY**



**Attorney-in-Fact** and FL Licensed Agent  
Cheryl E. Torrao

16118 N Florida Av, Lutz FL 33549 (813)968-8031



# AMERICAN SOUTHERN INSURANCE COMPANY

Home Office: 3715 Northside Parkway, NW  
Bldg. 400, Suite 800  
Atlanta, Georgia 30327

Mailing Address: P. O. Box 723030  
Atlanta, GA 31139-0030

## GENERAL POWER OF ATTORNEY

Know all men by these Presents, that the American Southern Insurance Company had made, constituted and appointed, and by these presents does make, constitute and appoint Stefan E. Tauger of Parker, Colorado; Donald J. Kersey of Birmingham, Alabama; Arthur S. Johnson of Atlanta, Georgia; Donald H. Gibbs of Atlanta, Georgia; Andrew C. Heaner of Atlanta, Georgia; Richard L. Shanahan of Atlanta, Georgia; Katherine S. Grimsley of Tampa, Florida; Jeffery L. Booth of Parma, Ohio; James E. Feldner of West Lake, Ohio; Cheryl L. Torrao of Canton, Georgia; Garry W. Black of Murfreesboro, Tennessee; Martha G. Ross of Charlotte, North Carolina; David R. Brett of Columbia, South Carolina; or Diane L. McLain of Fitchburg, Wisconsin, EACH as its true and lawful attorney for it and its name, place and stead to execute on behalf of the said company, as surety, bonds, undertakings and contracts of suretyship to be given to all obligees provided that no bond or undertaking or contract of suretyship executed under this authority shall exceed in amount of the sum of \$1,000,000 (one million dollars), including but not limited to consents of surety for the release of retained percentages and/or final estimates on construction contracts or similar authority requested by the Department of Transportation, State of Florida; and the execution of such undertakings, bonds, recognizances and other surety obligations, in pursuance of the presents, shall be as binding upon the Company as if they had been duly signed by the President and attested by the Secretary of the Company in their own proper persons.

This Power of Attorney is granted and is signed and sealed by facsimile under and by the authority of the following Resolution adopted pursuant to due authorization by the Executive Committee of the Board of Directors of the American Southern Insurance Company on the 26th day of May, 1998:

RESOLVED, that the Chairman, President or any Vice President of the Company be, and that each or any of them hereby is, authorized to execute Powers of Attorney qualifying the attorney named in the given Power of Attorney to execute in behalf of the American Southern Insurance Company bonds, undertakings and all contracts of suretyship; and that any Secretary or any Assistant Secretary be, and that each or any of them hereby is, authorized to attest the execution of any such Power of Attorney, and to attach thereto the seal of the Company.

FURTHER RESOLVED, that the signature of such officers and the seal of the Company may be affixed to any such Power of Attorney or to any certificate relating thereto by facsimile, and any such Power of Attorney or certificate bearing such facsimile signatures or facsimile seal shall be valid and binding upon the Company when so affixed and in the future, with respect to any bond undertaking or contract of suretyship to which it is attached.

In Witness Whereof, the American Southern Insurance Company has caused its official seal to be hereto affixed, and these presents to be signed by its President and attested by its Secretary this 17th day of December, 2009.

Attest:   
Gail A. Lee, Secretary

American Southern Insurance Company  
By:   
Scott G. Thompson, President

STATE OF GEORGIA  
SS:  
COUNTY OF FULTON

On this 17th day of December, 2009, before me personally came Scott G. Thompson to me known, who being by me duly sworn, did depose and say that he resides in Atlanta, in the County of Fulton, State of Georgia, at 421 Hollydale Court; that he is the President of American Southern Insurance Company, the corporation described in and which executed the above instrument; that he knows the seal of the said corporation, that the seal affixed to the said instrument is such corporate seal; that it was so affixed and that he signed his name thereto pursuant to due authorization

STATE OF GEORGIA  
SS:  
COUNTY OF FULTON

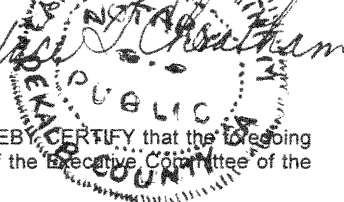
Candace T. Cheatham  
Notary Public, State of Georgia  
Qualified in DeKalb County  
Commission Expires December 7, 2013  

I, the undersigned, a Vice President of American Southern Insurance Company, a Kansas Corporation, DO HEREBY CERTIFY that the foregoing and attached Power of Attorney remains in full force and has not been revoked; and, furthermore, that the Resolution of the Executive Committee of the Board of Directors set forth in the Power of Attorney is now in force.

Signed and sealed at the City of Atlanta, Dated the 16th day of Feb 2011

  
John R. Huot  
Vice President

Power No. 22294

**SUBCONTRACTORS**

The Bidder further proposes that the following subcontracting firms or businesses will be awarded subcontracts for the following portions of the work in the event that the Bidder is awarded the Contract:

Portion of Work: ELECTRICAL

Name: FLORIDA KEYS ELECTRIC, INC.

Address: 5730 SECOND AVENUE, KEY WEST, FL 33040

Portion of Work: PLUMBING

Name: GARY'S PLUMBING, INC.

Address: 6409 SECOND TERRACE, #1, KEY WEST, FL 33040

Portion of Work: \_\_\_\_\_

Name: \_\_\_\_\_

Address: \_\_\_\_\_

**BIDDER**

The name of the Bidder submitting this Bid is: BELLA CONSTRUCTION OF KEY WEST, INC.

Doing business at 111 US HIGHWAY 1

City KEY WEST State FL Zip 33040

Telephone No. 305.292.9888

This address is where all communications concerning this Bid shall be sent.

The names of the principal officers of the Corporation submitting this Bid, or of the Partnership, or of all persons interested in this Bid as Principals are as follows:

Name	Title
EDGAR G BRASWELL, IV	PRESIDENT
-----	-----
-----	-----
-----	-----

**If Corporation**

IN WITNESS WHEREOF the undersigned corporation has caused this instrument to be executed and its seal affixed by its duly authorized officers this 16 day of FEBRUARY, 2011.

(SEAL)

Name of Corporation

By: EDGAR G BRASWELL, IV

Title: PRESIDENT

Attest: *Edgar G Braswell IV*

Secretary

**If Sole Proprietor or Partnership**

IN WITNESS hereto the undersigned has set his/her/its hand this 16 day of FEBRUARY, 2011.

Signature of Bidder *Edgar G Braswell IV*

Title PRESIDENT

**SWORN STATEMENT UNDER SECTION 287.133(3)(a)  
FLORIDA STATUTES, ON PUBLIC ENTITY CRIMES**

**PROJECT ITB #11-006: ADD DOCUMENT NAME HERE**

**THIS FORM MUST BE SIGNED IN THE PRESENCE OF A NOTARY PUBLIC OR  
OTHER OFFICE AUTHORIZED TO ADMINISTER OATHS.**

1. This sworn statement is submitted with Bid, Bid or Contract No.

ITB #11-006 for  
BAYVIEW PARK RESTROOM CONSTRUCTION

2. This sworn statement is submitted by

BELLA CONSTRUCTION OF KEY WEST, INC

(Name of entity submitting sworn statement)

whose business address is

111 US HIGHWAY 1, KEY WEST, FL 33040

----- and (if

applicable) its Federal Employer Identification Number (FEIN) is

27-0952862 (If the entity has no FEIN, include the Social

Security Number of the individual signing this sworn statement.)

3. My name is EDGAR G BRASWELL, IV and my  
relationship to

(Please print name of individual signing)

the entity named above is PRESIDENT.

4. I understand that a "public entity crime" as defined in Paragraph 287.133(1)(g), Florida Statutes, means a violation of any state or federal law by a person with respect to and directly related to the transaction of business with any public entity or with an agency or political subdivision of any other state or with the United States, including but not limited to, any Bid or contract for goods or services to be provided to any public entity or an agency or political subdivision of any other state or of the United States and involving antitrust, fraud, theft, bribery, collusion, racketeering, conspiracy, material misrepresentation.

5. I understand that "convicted" or "conviction" as defined in Paragraph 287.133(1)(b), Florida Statutes, means a finding of guilt or a conviction of a public entity crime, with or without an adjudication of guilt, in any federal or state trial court of record relating to charges brought by indictment information after July 1, 1989, as a result of a jury verdict, nonjury trial, or entry of a plea of guilty or nolo contendere.

6. I understand that an "affiliate" as defined in Paragraph 287.133(1)(a), Florida Statutes, means

1. A predecessor or successor of a person convicted of a public entity crime: or

2. An entity under the control of any natural person who is active in the management of the entity and who has been convicted of a public entity crime. The term "affiliate" includes those officers, directors, executives, partners, shareholders, employees, members, and agents who are active in the management of an affiliate. The ownership by one person of shares constituting controlling interest in another person, or a pooling of equipment or income among persons when not for fair market value under an arm's length agreement, shall be a prima facie case that one person controls another person. A person who knowingly enters into a joint venture with a person who has been convicted of a public entity crime in Florida during the preceding 36 months shall be considered an affiliate.

7. I understand that a "person" as defined in Paragraph 287.133(1)(8), Florida Statutes, means any natural person or entity organized under the laws of any state or of the United States with the legal power to enter into a binding contract and which Bids or applies to Bid on contracts for the provision of goods or services let by a public entity, or which otherwise transacts or applies to transact business with a public entity. The term "person" includes those officers, directors, executives, partners, shareholders, employees, members, and agents who are active in management of an entity.

8. Based on information and belief, the statement, which I have marked below, is true in relation to the entity submitting this sworn statement. (Please indicate which statement applies.)

X Neither the entity submitting this sworn statement, nor any officers, directors, executives, partners, shareholders, employees, members, or agents who are active in management of the entity, nor any affiliate of the entity have been charged with and convicted of a public entity crime subsequent to July 1, 1989.

\_\_\_ The entity submitting this sworn statement, or one or more of the officers, directors, executives, partners, shareholders, employees, members, or agents who are active in management of the entity, or an affiliate of the entity has been charged with and convicted of a public entity crime subsequent to July 1, 1989, AND (Please indicate which additional statement applies.)

\_\_\_ There has been a proceeding concerning the conviction before a hearing of the State

of Florida, Division of Administrative Hearings. The final order entered by the hearing officer did not place the person or affiliate on the convicted vendor list. (Please attach a copy of the final order.)

     The person or affiliate was placed on the convicted vendor list. There has been a subsequent proceeding before a hearing officer of the State of Florida, Division of Administrative Hearings. The final order entered by the hearing officer determined that it was in the public interest to remove the person or affiliate from the convicted vendor list. (Please attach a copy of the final order.)

     The person or affiliate has not been put on the convicted vendor list. (Please describe any action taken by or pending with the Department of General Services.)

Edgar G Braswell IV

(Signature)

2.16.11

(Date)

STATE OF FLORIDA

COUNTY OF MONROE

PERSONALLY APPEARED BEFORE ME, the undersigned authority,

EDGAR G BRASWELL, IV who, after first being sworn by me, affixed his/her signature in the  
(Name of individual signing)

space provided above on this 16 day of FEBRUARY, 2011.

My commission expires: 5.14.14

[Signature]  
NOTARY PUBLIC



**ANTI-KICKBACK AFFIDAVIT**

PROJECT ITB #11-006 : ADD DOCUMENT NAME HERE

STATE OF FLORIDA                    )  
  : SS  
COUNTY OF MONROE                )

I, the undersigned hereby duly sworn, depose and say that no portion of the sum herein Bid will be paid to any employees of the City of Key West as a commission, kickback, reward or gift, directly or indirectly by me or any member of my firm or by an officer of the corporation.

By: Edgar J. Braxton IV

Sworn and subscribed before me this

16 day of FEBRUARY, 2011.

*Rachel Bashore*  
NOTARY PUBLIC, State of Florida at Large



My Commission Expires: 5.14.14

**LOCAL VENDOR CERTIFICATION PURSUANT TO CKW ORDINANCE 09-22  
SECTION 2-798**

The undersigned, as a duly authorized representative of the vendor listed herein, certifies to the best of his/her knowledge and belief, that the vendor meets the definition of a "Local Business." For purposes of this section, "local business" shall mean a business which:

- a. Principle address as registered with the FL Department of State located within 30 miles of the boundaries of the city, listed with the chief licensing official as having a business tax receipt with its principle address within 30 miles of the boundaries of the city for at least one year immediately prior to the issuance of the solicitation.
- b. Maintains a workforce of at least 50 percent of its employees from the city or within 30 miles of its boundaries.
- c. Having paid all current license taxes and any other fees due the city at least 24 hours prior to the publication of the call for bids or request for proposals.
  - Not a local vendor pursuant to Ordinance 09-22 Section 2-798
  - Qualifies as a local vendor pursuant to Ordinance 09-22 Section 2-798

If you qualify, please complete the following in support of the self certification & submit copies of your County and City business licenses. Failure to provide the information requested will result in denial of certification as a local business.

Business Name BELLA CONSTRUCTION OF KEY WEST, INC Phone: 305.292.9888  
 Current Local Address: 111 US HIGHWAY 1, KEY WEST, FL 33040 Fax: 305.292.9880  
 (P.O Box numbers may not be used to establish status)

Length of time at this address 2 YEARS  
Edgar G Braswell IV 2.16.11  
 Signature of Authorized Representative Date

STATE OF FLORIDA  
 COUNTY OF MONROE

The foregoing instrument was acknowledged before me this 16 day of FEBRUARY 20 11.  
 By EDGAR G BRASWELL, IV, of BELLA CONSTRUCTION OF KEY WEST, INC  
 (Name of officer or agent, title of officer or agent) Name of corporation  
 acknowledging)  
 or has produced PERSONALLY KNOWN as identification  
 (type of identification)

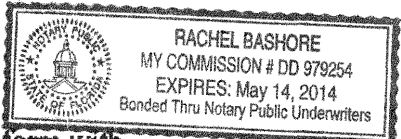

Rachel Bashore  
 Signature of Notary  
 RACHEL BASHORE

Return Completed form with  
 Supporting documents to:  
 City of Key West Purchasing

Print, Type or Stamp Name of Notary  
Notary Public  
 Title or Rank



# CITY OF KEY WEST, FLORIDA

## Business Tax Receipt

This Document is a business tax receipt  
Holder must meet all City zoning and use provisions.  
P.O. Box 1409, Key West, Florida 33040 (305) 809-3955

Business Name	BELLA CONSTRUCTION OF KEY WEST	CtlNbr:0019825
Location Addr	111 US HWY 1 110	
Lic NBR/Class	11-00024397 CONTRACTOR - CERT GENERAL CONTRACTOR	
Issue Date:	September 10, 2010	Expiration Date:September 30, 2011
License Fee	\$309.75	
Add. Charges	\$0.00	
Penalty	\$0.00	
Total	\$309.75	
Comments:		

---

This document must be prominently displayed.

BELLA CONSTRUCTION OF KEY WEST

BELLA CONSTRUCTION OF KEY WEST

111 US HWY 1 #110

KEY WEST FL 33040



AC# 4986906

STATE OF FLORIDA

DEPARTMENT OF BUSINESS AND PROFESSIONAL REGULATION  
CONSTRUCTION INDUSTRY LICENSING BOARD

SEQ# L10060700785

DATE	BATCH NUMBER	LICENSE NBR
06/07/2010	098172718	CGC1518284

The GENERAL CONTRACTOR

Named below IS CERTIFIED

Under the provisions of Chapter 489 FS.

Expiration date: AUG 31, 2012

BRASWELL, EDGAR GEORGE IV  
BELLA CONSTRUCTION OF KEY WEST INC  
111 US HWY 1 BOX 110  
ROCKLAND KEY FL 33040

CHARLIE CRIST  
GOVERNOR

CHARLIE LIEM  
INTERIM SECRETARY

DISPLAY AS REQUIRED BY LAW



<b><del>AGORD</del> CERTIFICATE OF LIABILITY INSURANCE</b>		DATE #/M/D/YY: 02/04/10
PRODUCT BY Milares Insurance Group 9560 SW 107 Ave Suite 203 Miami, FL 33176	THIS CERTIFICATE IS ISSUED AS A MATTER OF INFORMATION ONLY AND CONFERS NO RIGHTS UPON THE CERTIFICATE HOLDER. THIS CERTIFICATE DOES NOT AMEND, EXTEND OR ALTER THE COVERAGE AFFORDED BY THE POLICIES BELOW.	
INSURED Bella Construction 111 US Highway 1 Ste 110 Key West, FL 33040	INSURERS AFFORDING COVERAGE INSURER A: INSURER B: Allstate Property and Casualty INSURER C: INSURER D: INSURER E:	

**COVERAGES**

THE POLICIES OF INSURANCE LISTED BELOW HAVE BEEN ISSUED TO THE INSURED NAMED ABOVE FOR THE POLICY PERIOD INDICATED, NOTWITHSTANDING ANY REQUIREMENT, TERM OR CONDITION OF ANY CONTRACT OR OTHER DOCUMENT WITH RESPECT TO WHICH THIS CERTIFICATE MAY BE ISSUED OR MAY PERTAIN, THE INSURANCE AFFORDED BY THE POLICIES DESCRIBED HEREIN IS SUBJECT TO ALL THE TERMS, EXCLUSIONS AND CONDITIONS OF SUCH POLICIES. AGGREGATE LIMITS SHOWN MAY HAVE BEEN REDUCED BY PAID CLAIMS.

INSR / LTR	TYPE OF INSURANCE	POLICY NUMBER	POLICY EFFECTIVE DATE (MM/DD/YY)	POLICY EXPIRATION DATE (MM/DD/YY)	LIMITS
	GENERAL LIABILITY <input type="checkbox"/> COMMERCIAL GENERAL LIABILITY <input type="checkbox"/> CLAIMS MADE <input checked="" type="checkbox"/> OCCUR  GEN'L AGGREGATE LIMIT APPLIES PER: <input type="checkbox"/> POLICY <input type="checkbox"/> PRO. SECT <input type="checkbox"/> LOC				EACH OCCURRENCE \$ FIRE DAMAGE (Any one fire) \$ MED EXP (Any one person) \$ PERSONAL & ADV INJURY \$ GENERAL AGGREGATE \$ PRODUCTS - COMPROP AGG \$
B	AUTOMOBILE LIABILITY <input checked="" type="checkbox"/> ANY AUTO <input type="checkbox"/> ALL OWNED AUTOS <input type="checkbox"/> SCHEDULED AUTOS <input checked="" type="checkbox"/> HIRED AUTOS <input checked="" type="checkbox"/> NON-OWNED AUTOS	048928641	01/16/10	01/16/11	COMBINED SINGLE LIMIT (Ea accident) \$ 1,000,000 BODILY INJURY (Per person) \$ BODILY INJURY (Per accident) \$ PROPERTY DAMAGE (Per accident) \$
	GARAGE LIABILITY <input type="checkbox"/> ANY AUTO				AUTO ONLY - EA ACCIDENT \$ OTHER THAN EA ACC \$ AUTO ONLY: AGG \$
	EXCESS LIABILITY <input type="checkbox"/> OCCUR <input type="checkbox"/> CLAIMS MADE  <input type="checkbox"/> DEDUCTIBLE <input type="checkbox"/> RETENTION \$				EACH OCCURRENCE \$ AGGREGATE \$ \$ \$
	WORKERS COMPENSATION AND EMPLOYERS' LIABILITY				WC STATUTORY LIMITS BOTH \$ E.L. EACH ACCIDENT \$ E.L. DISEASE - EA EMPLOYEE \$ E.L. DISEASE - POLICY LIMIT \$
	OTHER				

DESCRIPTION OF OPERATIONS/LOCATIONS/VEHICLES/EXCLUSIONS ADDED BY ENDORSEMENT/SPECIAL PROVISIONS

CERTIFICATE HOLDER City of Key West 604 Simonon Street Key West, FL 33040 (FAX) 305-809-3978	ADDITIONAL INSURED; INSURER LETTER:	CANCELLATION SHOULD ANY OF THE ABOVE DESCRIBED POLICIES BE CANCELLED BEFORE THE EXPIRATION DATE THEREOF, THE ISSUING INSURER WILL ENDEAVOR TO MAIL 30 DAYS WRITTEN NOTICE TO THE CERTIFICATE HOLDER NAMED TO THE LEFT, BUT FAILURE TO DO SO SHALL IMPOSE NO OBLIGATION OR LIABILITY OF ANY KIND UPON THE INSURER, ITS AGENTS OR REPRESENTATIVES. AUTHORIZED REPRESENTATIVE:
--	-------------------------------------	---



# CERTIFICATE OF LIABILITY INSURANCE

DATE (MM/DD/YYYY)  
12/31/2010

THIS CERTIFICATE IS ISSUED AS A MATTER OF INFORMATION ONLY AND CONFERS NO RIGHTS UPON THE CERTIFICATE HOLDER. THIS CERTIFICATE DOES NOT AFFIRMATIVELY OR NEGATIVELY AMEND, EXTEND OR ALTER THE COVERAGE AFFORDED BY THE POLICIES BELOW. THIS CERTIFICATE OF INSURANCE DOES NOT CONSTITUTE A CONTRACT BETWEEN THE ISSUING INSURER(S), AUTHORIZED REPRESENTATIVE OR PRODUCER, AND THE CERTIFICATE HOLDER.

**IMPORTANT:** If the certificate holder is an ADDITIONAL INSURED, the policy(ies) must be endorsed. If SUBROGATION IS WAIVED, subject to the terms and conditions of the policy, certain policies may require an endorsement. A statement on this certificate does not confer rights to the certificate holder in lieu of such endorsement(s).

<b>PRODUCER</b> Mark van Wert c/o Willis of Florida, Inc. 3000 Bayport Drive, Suite 300 Tampa, FL 33607	<b>CONTACT NAME:</b> PHONE (A/C, No, Ext): (813) 281-2095      FAX (A/C, No): (813) 281-2234	
	<b>E-MAIL ADDRESS:</b> PRODUCER CUSTOMER ID #:	
<b>INSURED</b> Employee Leasing Solutions, Inc. Alt. Emp: Bella Construction of Key West Inc 1401 Manatee Avenue West Suite 600 Bradenton, FL 34205-6708	<b>INSURER(S) AFFORDING COVERAGE</b> NAIC #	
	<b>INSURER A:</b> American Zurich Insurance Company      40142	
	<b>INSURER B:</b>	
	<b>INSURER C:</b>	
	<b>INSURER D:</b>	
	<b>INSURER E:</b>	

**COVERAGES**      **CERTIFICATE NUMBER:** 10FL079807774      **REVISION NUMBER:**

THIS IS TO CERTIFY THAT THE POLICIES OF INSURANCE LISTED BELOW HAVE BEEN ISSUED TO THE INSURED NAMED ABOVE FOR THE POLICY PERIOD INDICATED. NOTWITHSTANDING ANY REQUIREMENT, TERM OR CONDITION OF ANY CONTRACT OR OTHER DOCUMENT WITH RESPECT TO WHICH THIS CERTIFICATE MAY BE ISSUED OR MAY PERTAIN, THE INSURANCE AFFORDED BY THE POLICIES DESCRIBED HEREIN IS SUBJECT TO ALL THE TERMS, EXCLUSIONS AND CONDITIONS OF SUCH POLICIES. LIMITS SHOWN MAY HAVE BEEN REDUCED BY PAID CLAIMS.

INSR LTR	TYPE OF INSURANCE	ADDL SUBR INSR WVD	POLICY NUMBER	POLICY EFF (MM/DD/YYYY)	POLICY EXP (MM/DD/YYYY)	LIMITS
	<b>GENERAL LIABILITY</b> <input type="checkbox"/> COMMERCIAL GENERAL LIABILITY <input type="checkbox"/> CLAIMS-MADE <input type="checkbox"/> OCCUR  GEN'L AGGREGATE LIMIT APPLIES PER: <input type="checkbox"/> POLICY <input type="checkbox"/> PRO-JECT <input type="checkbox"/> LOC					EACH OCCURRENCE \$ DAMAGE TO RENTED PREMISES (Ea occurrence) \$ MED EXP (Any one person) \$ PERSONAL & ADV INJURY \$ GENERAL AGGREGATE \$ PRODUCTS - COMP/OP AGG \$ \$
	<b>AUTOMOBILE LIABILITY</b> <input type="checkbox"/> ANY AUTO <input type="checkbox"/> ALL OWNED AUTOS <input type="checkbox"/> SCHEDULED AUTOS <input type="checkbox"/> HIRED AUTOS <input type="checkbox"/> NON-OWNED AUTOS					COMBINED SINGLE LIMIT (Ea accident) \$ BODILY INJURY (Per person) \$ BODILY INJURY (Per accident) \$ PROPERTY DAMAGE (Per accident) \$ \$ \$
	<input type="checkbox"/> UMBRELLA LIAB <input type="checkbox"/> OCCUR <input type="checkbox"/> EXCESS LIAB <input type="checkbox"/> CLAIMS-MADE <input type="checkbox"/> DEDUCTIBLE <input type="checkbox"/> RETENTION \$					EACH OCCURRENCE \$ AGGREGATE \$ \$ \$
<b>A</b>	<b>WORKERS COMPENSATION AND EMPLOYERS' LIABILITY</b> ANY PROPRIETOR/PARTNER/EXECUTIVE OFFICER/MEMBER EXCLUDED? (Mandatory in NH) If yes, describe under DESCRIPTION OF OPERATIONS below	Y/N <input type="checkbox"/>	N/A WC 90-00-818-00	12/31/2010	12/31/2011	<input checked="" type="checkbox"/> WC STATUTORY LIMITS <input type="checkbox"/> OTHER E.L. EACH ACCIDENT \$ 1,000,000 E.L. DISEASE - EA EMPLOYEE \$ 1,000,000 E.L. DISEASE - POLICY LIMIT \$ 1,000,000
<b>Location Coverage Period:</b> 12/31/2010    12/31/2011 <b>Client#:</b> 053006						

**DESCRIPTION OF OPERATIONS / LOCATIONS / VEHICLES (Attach ACORD 101, Additional Remarks Schedule, if more space is required)**  
 Coverage is provided for only those employees leased to but not subcontractors of: **Bella Construction of Key West Inc**  
 111 US Highway 1 #110  
 Key West, FL 33040

<b>CERTIFICATE HOLDER</b>  City of Key West PO Box 1409 Key West, FL 33041	<b>CANCELLATION</b>  SHOULD ANY OF THE ABOVE DESCRIBED POLICIES BE CANCELLED BEFORE THE EXPIRATION DATE THEREOF, NOTICE WILL BE DELIVERED IN ACCORDANCE WITH THE POLICY PROVISIONS.
	AUTHORIZED REPRESENTATIVE 

© 1988-2009 ACORD CORPORATION. All rights reserved.